

FCC TEST REPORT

(Part 15, Subpart E)



Applicant:	Sonim Technologies, Inc.
Address:	1875 S. Grant St., Suite 750., San Mateo, CA, 94402

Manufacturer or Supplier:	Sonim Technologies (Shenzhen) Limited
Address:	2nd Floor, No. 2 Building Phase B, Daqian Industrial park, Longchang Road, 67 District, Baoan, Shenzhen, P. R. China
Product:	Mobile Phone
Brand Name:	Sonim
Model Name:	XP3800
FCC ID:	WYPPC2223
Date of tests:	Oct. 09, 2018 ~ Dec. 20, 2018

The tests have been carried out according to the requirements of the following standard:

FCC Part 15, Subpart E, Section 15.407

CONCLUSION: The submitted sample was found to COMPLY with the test requirement

Prepared by Roger Li Engineer / Mobile Department	Approved by Sam Tung Manager / Mobile Department
	
Date: Dec. 21, 2018	Date: Dec. 21, 2018

This report is governed by, and incorporates by reference, CPS Conditions of Service as posted at the date of issuance of this report at <http://www.bureauveritas.com/home/about-us/our-business/cps/about-us/terms-conditions> and is intended for your exclusive use. Any copying or replication of this report to or for any other person or entity, or use of our name or trademark, is permitted only with our prior written permission. This report sets forth our findings solely with respect to the test samples identified herein. The results set forth in this report are not indicative or representative of the quality or characteristics of the lot from which a test sample was taken or any similar or identical product unless specifically and expressly noted. Our report includes all of the tests requested by you and the results thereof based upon the information that you provided to us. Measurement uncertainty is only provided upon request for accredited tests. You have 60 days from date of issuance of this report to notify us of any material error or omission caused by our negligence or if you require measurement uncertainty; provided, however, that such notice shall be in writing and shall specifically address the issue you wish to raise. A failure to raise such issue within the prescribed time shall constitute your unqualified acceptance of the completeness of this report, the tests conducted and the correctness of the report contents.



TABLE OF CONTENTS

RELEASE CONTROL RECORD 4

1 SUMMARY OF TEST RESULTS..... 5

1.1 MEASUREMENT UNCERTAINTY 5

2 GENERAL INFORMATION 6

2.1 GENERAL DESCRIPTION OF EUT 6

2.2 DESCRIPTION OF TEST MODES 8

2.2.1 TEST MODE APPLICABILITY AND TESTED CHANNEL DETAIL..... 10

2.3 DUTY CYCLE OF TEST SIGNAL 13

2.4 DESCRIPTION OF SUPPORT UNITS 14

2.4.1 CONFIGURATION OF SYSTEM UNDER TEST 14

2.5 GENERAL DESCRIPTION OF APPLIED STANDARDS 15

3 TEST TYPES AND RESULTS..... 16

3.1 RADIATED EMISSION AND BANDEDGE MEASUREMENT 16

3.1.1 LIMITS OF RADIATED EMISSION AND BANDEDGE MEASUREMENT..... 16

3.1.2 LIMITS OF UNWANTED EMISSION 17

3.1.3 TEST INSTRUMENTS..... 18

3.1.4 TEST PROCEDURES 19

3.1.5 DEVIATION FROM TEST STANDARD 19

3.1.6 TEST SETUP 20

3.1.7 EUT OPERATING CONDITION 21

3.1.8 TEST RESULTS 22

3.2 CONDUCTED EMISSION MEASUREMENT 65

3.2.1 LIMITS OF CONDUCTED EMISSION MEASUREMENT 65

3.2.2 TEST INSTRUMENTS..... 65

3.2.3 TEST PROCEDURES 65

3.2.4 DEVIATION FROM TEST STANDARD 66

3.2.5 TEST SETUP 66

3.2.6 EUT OPERATING CONDITIONS 66

3.2.7 TEST RESULTS 67

3.3 MAXIMUM CONDUCTED OUTPUT POWER MEASUREMENT 71

3.3.1 LIMITS OF MAXIMUM CONDUCTED OUTPUT POWER MEASUREMENT 71

3.3.2 TEST SETUP 72



3.3.3	TEST INSTRUMENTS.....	72
3.3.4	TEST PROCEDURE.....	73
3.3.5	DEVIATION FROM TEST STANDARD	74
3.3.6	EUT OPERATING CONDITIONS	74
3.3.7	TEST RESULTS	75
3.4	MAXIMUM POWER SPECTRAL DENSITY MEASUREMENT.....	88
3.4.1	LIMITS OF MAXIMUM POWER SPECTRAL DENSITY MEASUREMENT	88
3.4.2	TEST SETUP.....	88
3.4.3	TEST INSTRUMENTS.....	88
3.4.4	TEST PROCEDURES	89
3.4.5	DEVIATION FROM TEST STANDARD	89
3.4.6	EUT OPERATING CONDITIONS	89
3.4.7	TEST RESULTS	90
3.5	FREQUENCY STABILITY	97
3.5.1	LIMITS OF FREQUENCY STABILITY MEASUREMENT.....	97
3.5.2	TEST SETUP.....	97
3.5.3	TEST INSTRUMENTS.....	97
3.5.4	TEST PROCEDURE.....	98
3.5.5	DEVIATION FROM TEST STANDARD	98
3.5.6	EUT OPERATING CONDITION	98
3.5.7	TEST RESULTS	99
4	PHOTOGRAPHS OF THE TEST CONFIGURATION.....	101
5	APPENDIX A – MODIFICATIONS RECORDERS FOR ENGINEERING CHANGES TO THE EUT BY THE LAB.....	102



Test Report No.: RF180829W002-3

RELEASE CONTROL RECORD

ISSUE NO.	REASON FOR CHANGE	DATE ISSUED
RF180829W002-3	Original release	Dec. 21, 2018



1 SUMMARY OF TEST RESULTS

The EUT has been tested according to the following specifications:

APPLIED STANDARD: FCC PART 15, SUBPART E (SECTION 15.407)			
STANDARD SECTION	TEST TYPE AND LIMIT	RESULT	REMARK
15.407(b)(5)	AC Power Conducted Emission	PASS	Meet the requirement of limit. Minimum passing margin is -9.17dB at 0.544000MHz.
15.407(b) (1/2/3/4/6)	Radiated Emission & Band Edge Measurement	PASS	Meet the requirement of limit. Minimum passing margin is -1.38dB at 5470MHz.
15.407(a/1/2/3)	Maximum conducted output Power	PASS	Meet the requirement of limit.
15.407(a/1/2/3)	Peak Power Spectral Density	PASS	Meet the requirement of limit.
15.407(e)	6 dB Bandwidth	PASS	Meet the requirement of limit. (U-NII-3 Band only)
15.407(g)	Frequency Stability	PASS	Meet the requirement of limit.
15.203	Antenna Requirement	PASS	No antenna connector is used.

1.1 MEASUREMENT UNCERTAINTY

Where relevant, the following measurement uncertainty levels have been estimated for tests performed on the EUT as specified in CISPR 16-4-2:

MEASUREMENT	FREQUENCY	UNCERTAINTY
Conducted emissions	9kHz~30MHz	2.66dB
Radiated emissions	9KHz ~ 30MHz	2.68dB
	30MHz ~ 1GMHz	3.26dB
	1GHz ~ 18GHz	4.48dB
	18GHz ~ 40GHz	4.12dB

This uncertainty represents an expanded uncertainty expressed at approximately the 95% confidence level using a coverage factor of $k = 2$.



2 GENERAL INFORMATION

2.1 GENERAL DESCRIPTION OF EUT

EUT	Mobile Phone
MODEL NO.	XP3800
POWER SUPPLY	5.0Vdc (adapter or host equipment) 3.7Vdc (Li-ion, battery)
MODULATION TYPE	64QAM, 16QAM, QPSK, BPSK
MODULATION TECHNOLOGY	OFDM
TRANSFER RATE	802.11a: 54.0/ 48.0/ 36.0/ 24.0/ 18.0/ 12.0/ 9.0/ 6.0Mbps 802.11n: up to MCS7
OPERATING FREQUENCY	5180 ~ 5240MHz, 5260 ~ 5320MHz, 5500 ~ 5700MHz, 5745 ~ 5825MHz
NUMBER OF CHANNEL	5180 ~ 5240MHz: 4 for 802.11a, 802.11n (20MHz) 2 for 802.11n (40MHz) 5260 ~ 5320MHz: 4 for 802.11a, 802.11n (20MHz) 2 for 802.11n (40MHz) 5500 ~ 5700MHz: 8 for 802.11a, 802.11n (20MHz) 3 for 802.11n (40MHz) 5745 ~ 5825MHz: 5 for 802.11a, 802.11n (20MHz) 2 for 802.11n (40MHz)
AVERAGE POWER	41.69mW for 5180 ~ 5240MHz 39.54mW for 5260 ~ 5320MHz 37.15mW for 5500 ~ 5700MHz 46.34mW for 5745 ~ 5825MHz
ANTENNA TYPE	PIFA Antenna with 2dBi gain
HW VERSION	DVT2
SW VERSION	3A.0.0-00-8.1.0-29.09.04
I/O PORTS	Refer to user's manual
CABLE SUPPLIED	USB cable: non-shielded, detachable, 1.5meter

NOTE:

- For a more detailed features description, please refer to the manufacturer's specifications or the user's manual.
- The EUT was powered by the following adapters:

ADAPTER 1	
BRAND:	Sonim
MODEL:	TUUS050100-K00
INPUT:	AC 100-240V, 200mA
OUTPUT:	DC 5V, 1000mA



ADAPTER 2	
BRAND:	Sonim
MODEL:	AQ05A-050B
INPUT:	AC 100-240V, 200mA
OUTPUT:	DC 5V, 1000mA

3. The EUT matched the following USB cable:

USB CABLE	
BRAND:	N.A
MODEL:	N.A
SIGNAL LINE:	1.5 METER

4. The EUT incorporates a SISO function. Physically, the EUT provides one completed transmitter and one receiver.

MODULATION MODE	TX FUNCTION
802.11a	1TX/1RX
802.11n (20MHz)	1TX/1RX
802.11n (40MHz)	1TX/1RX

5. For the test results, the EUT had been tested with all conditions. But only the worst case was shown in test report.



2.2 DESCRIPTION OF TEST MODES

FOR 5150 ~ 5250MHz

4 channels are provided for 802.11a, 802.11n (20MHz):

CHANNEL	FREQUENCY	CHANNEL	FREQUENCY
36	5180 MHz	44	5220 MHz
40	5200 MHz	48	5240 MHz

2 channels are provided for 802.11n (40MHz):

CHANNEL	FREQUENCY	CHANNEL	FREQUENCY
38	5190 MHz	46	5230 MHz

FOR 5250 ~ 5350MHz

4 channels are provided for 802.11a, 802.11n (20MHz):

CHANNEL	FREQUENCY	CHANNEL	FREQUENCY
52	5260 MHz	60	5300 MHz
56	5280 MHz	64	5320 MHz

2 channels are provided for 802.11n (40MHz):

CHANNEL	FREQUENCY	CHANNEL	FREQUENCY
54	5270 MHz	62	5310 MHz



FOR 5470 ~ 5725MHz

8 channels are provided for 802.11a, 802.11n (20MHz):

CHANNEL	FREQUENCY	CHANNEL	FREQUENCY
100	5500 MHz	116	5580 MHz
104	5520 MHz	132	5660 MHz
108	5540 MHz	136	5680 MHz
112	5560 MHz	140	5700 MHz

3 channels are provided for 802.11n (40MHz):

CHANNEL	FREQUENCY	CHANNEL	FREQUENCY
102	5510 MHz	134	5670 MHz
110	5550 MHz		

FOR 5725 ~ 5825MHz

5 channels are provided for 802.11a, 802.11n (20MHz):

CHANNEL	FREQUENCY	CHANNEL	FREQUENCY
149	5745 MHz	161	5805 MHz
153	5765 MHz	165	5825 MHz
157	5785 MHz		

2 channels are provided for 802.11n (40MHz):

CHANNEL	FREQUENCY	CHANNEL	FREQUENCY
151	5755 MHz	159	5795 MHz



2.2.1 TEST MODE APPLICABILITY AND TESTED CHANNEL DETAIL

EUT CONFIGURE MODE	APPLICABLE TO				DESCRIPTION
	RE≥1G	RE<1G	PLC	APCM	
A	√	√	√	-	Powered by Adapter with wifi(5G) link
B	-	-	-	√	Powered by Battery with wifi(5G) link
C	-	-	-	-	Powered by USB with wifi(5G) link

Where **RE≥1G**: Radiated Emission above 1GHz **RE<1G**: Radiated Emission below 1GHz
PLC: Power Line Conducted Emission **APCM**: Antenna Port Conducted Measurement

NOTE:

The EUT had been pre-tested on the positioned of each 3 axis. The worst case was found when positioned on **X-plane**.

NOTE: "-" means no effect.

RADIATED EMISSION TEST (ABOVE 1GHz):

- Pre-Scan has been conducted to determine the worst-case mode from all possible combinations between available modulations, data rates and antenna ports (if EUT with antenna diversity architecture).
- Following channel(s) was (were) selected for the final test as listed below.

EUT CONFIGURE MODE	MODE	FREQ. BAND (MHz)	AVAILABLE CHANNEL	TESTED CHANNEL	MODULATION TECHNOLOGY	MODULATION TYPE	DATA RATE (Mbps)
A	802.11a	5180-5240	36 to 48	36, 40, 48	OFDM	BPSK	6.0
A	802.11n (20MHz)		36 to 48	36, 40, 48	OFDM	BPSK	MCS0
A	802.11n (40MHz)		38 to 46	38, 46	OFDM	BPSK	MCS0
A	802.11a	5260-5320	52 to 64	52, 60, 64	OFDM	BPSK	6.0
A	802.11n (20MHz)		52 to 64	52, 60, 64	OFDM	BPSK	MCS0
A	802.11n (40MHz)		54 to 62	54, 62	OFDM	BPSK	MCS0
A	802.11a	5500-5700	100 to 140	100, 116, 140	OFDM	BPSK	6.0
A	802.11n (20MHz)		100 to 140	100, 116, 140	OFDM	BPSK	MCS0
A	802.11n (40MHz)		102 to 134	102, 110, 134	OFDM	BPSK	MCS0
A	802.11a	5725-5825	149 to 165	149, 157, 165	OFDM	BPSK	6.0
A	802.11n (20MHz)		149 to 165	149, 157, 165	OFDM	BPSK	MCS0
A	802.11n (40MHz)		151 to 159	151, 159	OFDM	BPSK	MCS0



RADIATED EMISSION TEST (BELOW 1GHz):

- Pre-Scan has been conducted to determine the worst-case mode from all possible combinations between available modulations, data rates and antenna ports (if EUT with antenna diversity architecture).
- Following channel(s) was (were) selected for the final test as listed below.

EUT CONFIGURE MODE	MODE	FREQ. BAND (MHz)	AVAILABLE CHANNEL	TESTED CHANNEL	MODULATION TECHNOLOGY	MODULATION TYPE	DATA RATE (Mbps)
A	802.11n (40MHz)	5500-5700	102 to 134	110	OFDM	BPSK	MCS0

POWER LINE CONDUCTED EMISSION TEST:

- Pre-Scan has been conducted to determine the worst-case mode from all possible combinations between available modulations, data rates and antenna ports (if EUT with antenna diversity architecture).
- Following channel(s) was (were) selected for the final test as listed below.

EUT CONFIGURE MODE	MODE	FREQ. BAND (MHz)	AVAILABLE CHANNEL	TESTED CHANNEL	MODULATION TECHNOLOGY	MODULATION TYPE	DATA RATE (Mbps)
A	802.11n (40MHz)	5500-5700	102 to 134	110	OFDM	BPSK	MCS0

BANDEDGE MEASUREMENT:

- Pre-Scan has been conducted to determine the worst-case mode from all possible combinations between available modulations, data rates and antenna ports (if EUT with antenna diversity architecture).
- Following channel(s) was (were) selected for the final test as listed below.

EUT CONFIGURE MODE	MODE	FREQ. BAND (MHz)	AVAILABLE CHANNEL	TESTED CHANNEL	MODULATION TECHNOLOGY	MODULATION TYPE	DATA RATE (Mbps)
A	802.11a	5180-5240	36 to 48	36, 48	OFDM	BPSK	6.0
A	802.11n (20MHz)		36 to 48	36, 48	OFDM	BPSK	MCS0
A	802.11n (40MHz)		38 to 46	38, 46	OFDM	BPSK	MCS0
A	802.11a	5260-5320	52 to 64	52, 64	OFDM	BPSK	6.0
A	802.11n (20MHz)		52 to 64	52, 64	OFDM	BPSK	MCS0
A	802.11n (40MHz)		54 to 62	54, 62	OFDM	BPSK	MCS0
A	802.11a	5500-5700	100 to 140	100, 140	OFDM	BPSK	6.0
A	802.11n (20MHz)		100 to 140	100, 140	OFDM	BPSK	MCS0
A	802.11n (40MHz)		102 to 134	102, 134	OFDM	BPSK	MCS0
A	802.11a	5725-5825	149 to 165	149, 165	OFDM	BPSK	6.0
A	802.11n (20MHz)		149 to 165	149, 165	OFDM	BPSK	MCS0
A	802.11n (40MHz)		151 to 159	151, 159	OFDM	BPSK	MCS0

**ANTENNA PORT CONDUCTED MEASUREMENT:**

- This item includes all test value of each mode, but only includes spectrum plot of worst value of each mode.
- Pre-Scan has been conducted to determine the worst-case mode from all possible combinations between available modulations, data rates and antenna ports (if EUT with antenna diversity architecture).
- Following channel(s) was (were) selected for the final test as listed below.

EUT CONFIGURE MODE	MODE	FREQ. BAND (MHz)	AVAILABLE CHANNEL	TESTED CHANNEL	MODULATION TECHNOLOGY	MODULATION TYPE	DATA RATE (Mbps)
B	802.11a	5180-5240	36 to 48	36, 40, 48	OFDM	BPSK	6.0
B	802.11n (20MHz)		36 to 48	36, 40, 48	OFDM	BPSK	MCS0
B	802.11n (40MHz)		38 to 46	38, 46	OFDM	BPSK	MCS0
B	802.11a	5260-5320	52 to 64	52, 60, 64	OFDM	BPSK	6.0
B	802.11n (20MHz)		52 to 64	52, 60, 64	OFDM	BPSK	MCS0
B	802.11n (40MHz)		54 to 62	54, 62	OFDM	BPSK	MCS0
B	802.11a	5500-5700	100 to 140	100, 116, 140	OFDM	BPSK	6.0
B	802.11n (20MHz)		100 to 140	100, 116, 140	OFDM	BPSK	MCS0
B	802.11n (40MHz)		102 to 134	102, 110, 134	OFDM	BPSK	MCS0
B	802.11a	5725-5825	149 to 165	149, 165	OFDM	BPSK	6.0
B	802.11n (20MHz)		149 to 165	149, 165	OFDM	BPSK	MCS0
B	802.11n (40MHz)		151 to 159	151, 159	OFDM	BPSK	MCS0

TEST CONDITION:

APPLICABLE TO	ENVIRONMENTAL CONDITIONS	INPUT POWER	TESTED BY
RE<1G	23deg. C, 62%RH	DC 5V from adaptor	Rose Ma
RE≥1G	23deg. C, 62%RH	DC 5V from adaptor	Rose Ma
PLC	24deg. C, 61%RH	DC 5V from adaptor	John Wen
APCM	23.5deg. C, 60%RH	DC 3.7V from battery	Rain Wang



2.3 DUTY CYCLE OF TEST SIGNAL

Duty cycle of test signal is < 98%, duty factor shall be considered.

802.11a: Duty cycle = 1.360/1.562 = 0.871, Duty factor = 10 * log(1/0.870) = 0.60

802.11n (20MHz): Duty cycle = 1.273/1.475 = 0.863, Duty factor = 10 * log(1/0.861) = 0.64

802.11n (40MHz): Duty cycle = 0.633/0.837 = 0.756, Duty factor = 10 * log(1/0.761) = 1.21

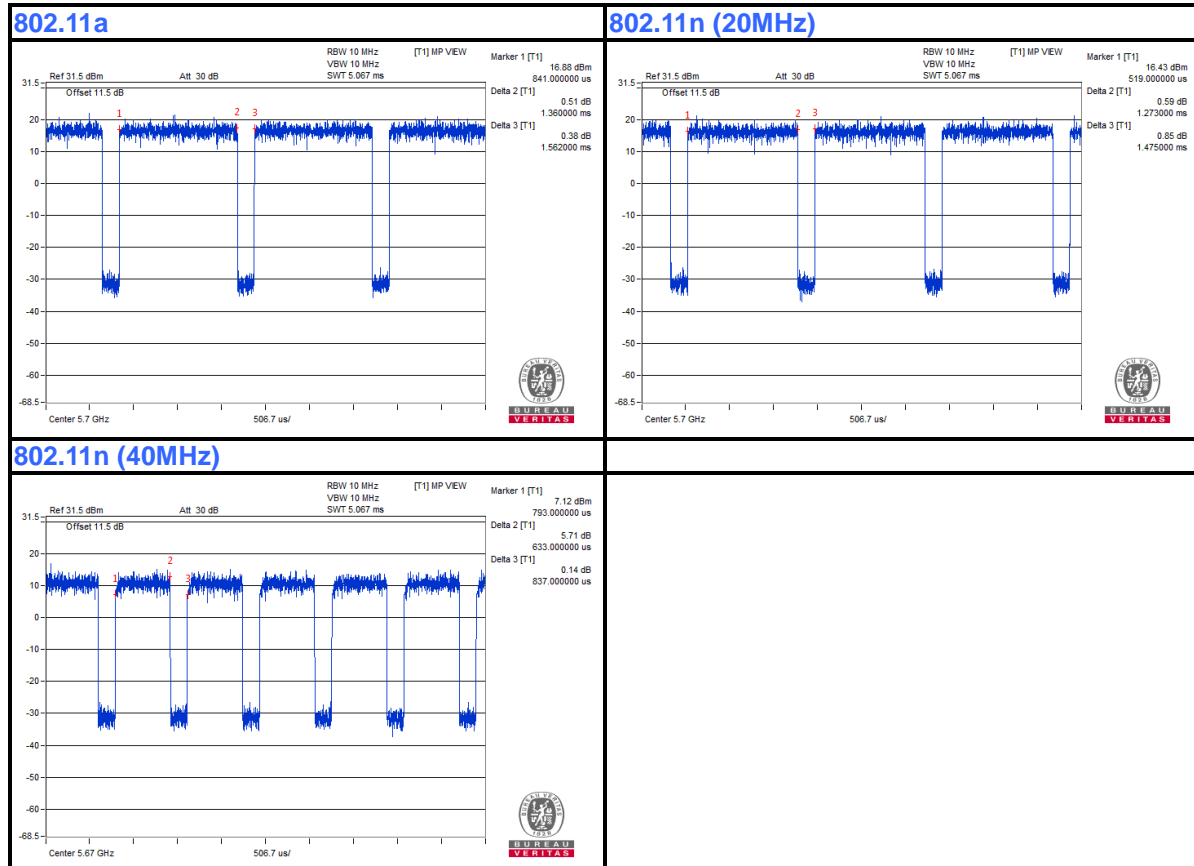



2.4 DESCRIPTION OF SUPPORT UNITS

The EUT has been tested as an independent unit together with other necessary accessories or support units. The following support units or accessories were used to form a representative test configuration during the tests.

NO.	PRODUCT	BRAND	MODEL NO.	SERIAL NO.	FCC ID
1	PC	HP	A6608CN	3CR83825X3	N/A

NO.	SIGNAL CABLE DESCRIPTION OF THE ABOVE SUPPORT UNITS
1	AC Line: Unshielded, Detachable 1.5m

NOTE:

1. All power cords of the above support units are non shielded (1.8m).

2.4.1 CONFIGURATION OF SYSTEM UNDER TEST

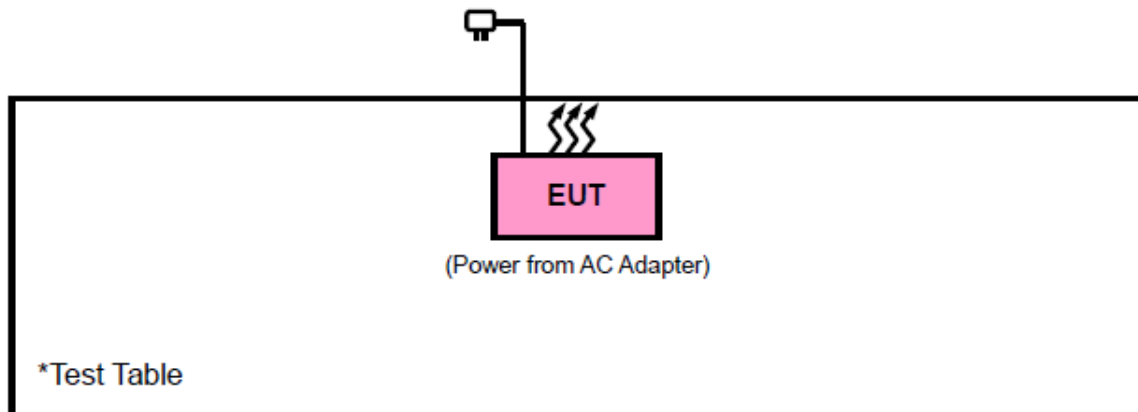



2.5 GENERAL DESCRIPTION OF APPLIED STANDARDS

The EUT is a RF Product. According to the specifications of the manufacturer, it must comply with the requirements of the following standards:

FCC Part 15, Subpart E (15.407)

KDB 789033 D02 General U-NII Test Procedures New Rules v02r01

ANSI C63.10-2013

All test items have been performed and recorded as per the above standards.

NOTE: The EUT is also considered as a kind of computer peripheral, because the connection to computer is necessary for typical use. It has been verified to comply with the requirements of FCC Part 15, Subpart B, Class B (Certification). The test report has been issued separately.



3 TEST TYPES AND RESULTS

3.1 RADIATED EMISSION AND BANDEDGE MEASUREMENT

3.1.1 LIMITS OF RADIATED EMISSION AND BANDEDGE MEASUREMENT

Radiated emissions which fall in the restricted bands must comply with the radiated emission limits specified as below table:

FREQUENCIES (MHz)	FIELD STRENGTH (microvolts/meter)	MEASUREMENT DISTANCE (meters)
0.009 ~ 0.490	2400/F(kHz)	300
0.490 ~ 1.705	24000/F(kHz)	30
1.705 ~ 30.0	30	30
30 ~ 88	100	3
88 ~ 216	150	3
216 ~ 960	200	3
Above 960	500	3

NOTE:

1. The lower limit shall apply at the transition frequencies.
2. Emission level (dBuV/m) = 20 log Emission level (uV/m).
3. For frequencies above 1000MHz, the field strength limits are based on average detector, however, the peak field strength of any emission shall not exceed the maximum permitted average limits, specified above by more than 20dB under any condition of modulation.



3.1.2 LIMITS OF UNWANTED EMISSION

RESTRICTED BANDS	APPLICABLE TO	LIMIT	
	789033 D02 General UNII Test Procedures New Rules v01r04	FIELD STRENGTH AT 3m (dBµV/m)	
		PK : 74	AV : 54
OUT OF THE RESTRICTED BANDS	APPLICABLE TO	EIRP LIMIT (dBm/MHz)	EQUIVALENT FIELD STRENGTH AT 3m (dBµV/m)
	15.407(b)(1)	PK : -27	PK : 68.3
	15.407(b)(2)		
	15.407(b)(3)		
15.407(b)(4)	See note 2 (FCC 16-24)		

NOTE: The following formula is used to convert the equipment isotropic radiated power (eirp) to field strength:

$$E = \frac{1000000\sqrt{30P}}{3} \mu\text{V/m, where P is the eirp (Watts).}$$

2. All emissions shall be limited to a level of -27 dBm/MHz at 75 MHz or more above or below the band edge increasing linearly to 10 dBm/MHz at 25 MHz above or below the band edge, and from 25 MHz above or below the band edge increasing linearly to a level of 15.6 dBm/MHz at 5 MHz above or below the band edge, and from 5 MHz above or below the band edge increasing linearly to a level of 27 dBm/MHz at the band edge.



3.1.3 TEST INSTRUMENTS

Equipment	Manufacturer	Model No.	Serial No.	Last Cal.	Next Cal.
3m Semi-anechoic Chamber	ETS-LINDGREN	9m*6m*6m	Euroshieldpn-CT0001143-1216	Apr. 21,18	Apr. 20,19
Bilog Antenna	ETS-LINDGREN	3143B	00161965	Mar. 15,18	Mar. 14,19
Horn Antenna	ETS-LINDGREN	3117	00168728	Mar. 15,18	Mar. 14,19
Loop antenna	Daze	ZN30900A	0708	Oct. 23,18	Oct. 22, 19
Horn Antenna (18GHz-40GHz)	N/A	QWH-SL-18-40-K-SG/QMS-00361	15433	Nov. 21, 18	Nov. 20, 19
Test Software	E3	V 9.160323	N/A	N/A	N/A
Test Software	ADT	ADT_Radiated_V7.6.15.9.2	N/A	N/A	N/A
10dB Attenuator	JFW/USA	50HF-010-SMA	1505	Jul. 09,18	Jul. 08,19
MXE EMI Receiver	KEYSIGHT	N9038A-544	MY54450026	Mar. 16,18	Mar. 15,19
Signal Pre-Amplifier	EMSI	EMC 9135	980249	Jul. 09,18	Jul. 08,19
Signal Pre-Amplifier	EMSI	EMC 012645B	980257	Jul. 09,18	Jul. 08,19
Signal Pre-Amplifier	EMSI	EMC 184045B	980259	Jul. 09,18	Jul. 08,19

NOTE:

1. The calibration interval of the above test instruments is 12 months and the calibrations are traceable to CEPREI/CHINA, GRGT/CHINA and NIM/CHINA.
2. The test was performed in 3m Chamber.
3. The FCC Site Registration No. is 525120; The Designation No. is CN1171.



3.1.4 TEST PROCEDURES

- a. The EUT was placed on the top of a rotating table 0.8 meters (for below 1GHz) / 1.5 meters (for above 1GHz) above the ground at 3 meter chamber room for test. The table was rotated 360 degrees to determine the position of the highest radiation.
- b. The EUT was set 3 meters away from the interference-receiving antenna, which was mounted on the top of a variable-height antenna tower.
- c. The antenna is a broadband antenna, and its height is varied from one meter to four meters above the ground to determine the maximum value of the field strength. Both horizontal and vertical polarizations of the antenna are set to make the measurement.
- d. For each suspected emission, the EUT was arranged to its worst case and then the antenna was tuned to heights from 1 meter to 4 meters and the rotatable table was turned from 0 degrees to 360 degrees to find the maximum reading.
- e. The test-receiver system was set to Peak Detect Function and Specified Bandwidth with Maximum Hold Mode.
- f. If the emission level of the EUT in peak mode was 10dB lower than the limit specified, then testing could be stopped and the peak values of the EUT would be reported. Otherwise the emissions that did not have 10dB margin would be re-tested one by one using peak, quasi-peak or average method as specified and then reported in a data sheet.

NOTE:

1. The resolution bandwidth and video bandwidth of test receiver/spectrum analyzer is 120kHz for Peak detection (PK) and Quasi-peak detection (QP) at frequency below 1GHz.
2. The resolution bandwidth of test receiver/spectrum analyzer is 1MHz and video bandwidth is 3MHz for Peak detection at frequency above 1GHz.
3. The resolution bandwidth of test receiver/spectrum analyzer is 1MHz and the video bandwidth is 10Hz for Average detection (AV) at frequency above 1GHz.
4. All modes of operation were investigated and the worst-case emissions are reported.

3.1.5 DEVIATION FROM TEST STANDARD

No deviation.



3.1.6 TEST SETUP

< Frequency Range below 30MHz >

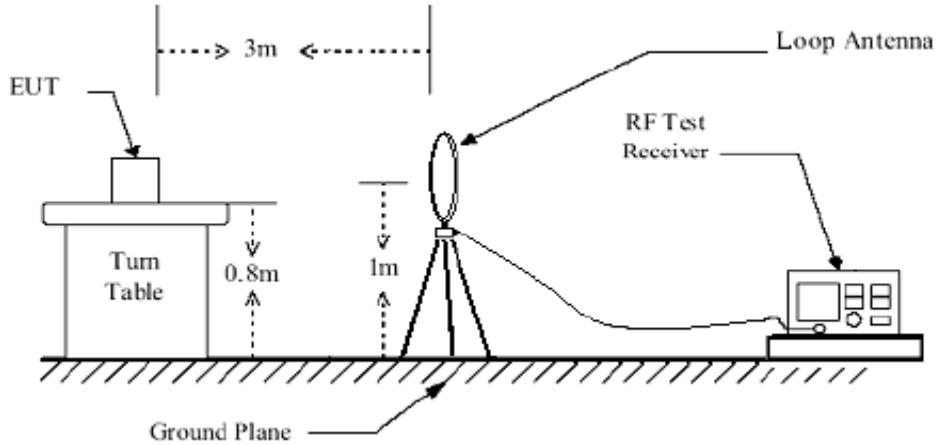

< Frequency Range 30MHz~1GHz >

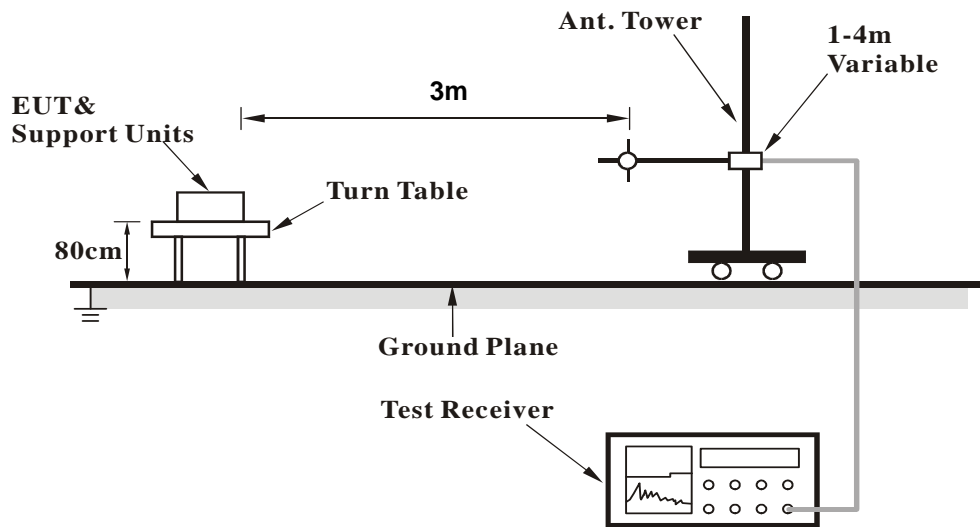



<Frequency Range above 1GHz>

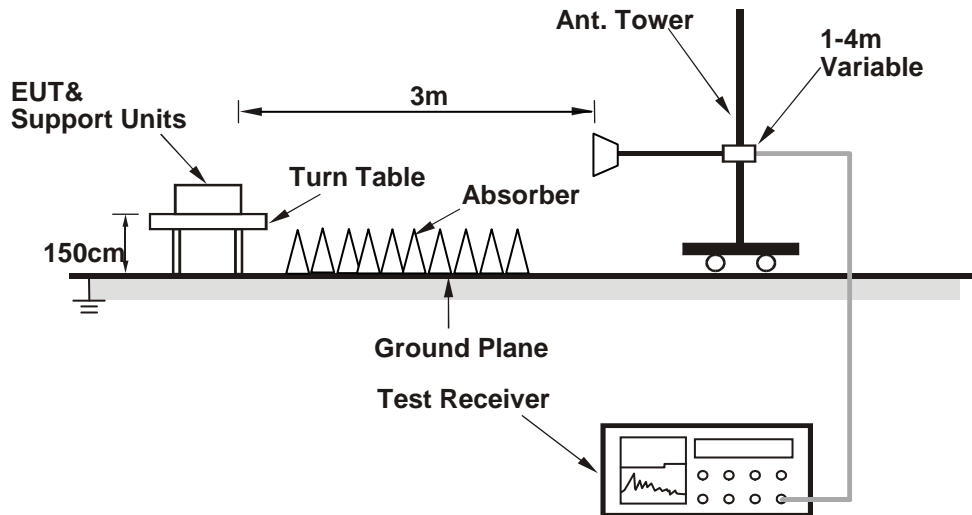

For the actual test configuration, please refer to the attached file (Test Setup Photo).

3.1.7 EUT OPERATING CONDITION

- Set the EUT under full load condition and placed them on a testing table.
- Set the transmitter part of EUT under transmission condition continuously at specific channel frequency.
- The necessary accessories enable the EUT in full functions.



3.1.8 TEST RESULTS

BELOW 1GHz WORST-CASE DATA:

9 KHz – 30 MHz data: the amplitude of spurious emissions attenuated more than 20 dB below the permissible value is not required in the report.

30 MHz – 1GHz data:

802.11n (40MHz)

CHANNEL	TX Channel 110	DETECTOR FUNCTION	Quasi-Peak (QP)
FREQUENCY RANGE	30MHz ~ 1GHz		

ANTENNA POLARITY & TEST DISTANCE: HORIZONTAL AT 3 M										
FREQ. (MHz)	EMISSION LEVEL (dBuV/m)	READ LEVEL (dBuV)	LIMIT (dBuV/m)	MARGIN (dB)	ANTENNA FACTOR (dB /m)	CABLE LOSS (dB)	PREAMP FACTOR (dB)	ANTENNA HEIGHT (cm)	TABLE ANGLE (Degree)	REMARK
78.45	19.49	48.65	40	-20.51	6.65	1.36	37.17	100	120	QP
134.72	30.29	57.59	43.5	-13.21	7.79	1.78	36.87	100	78	QP
256.02	30.59	52.16	46	-15.41	12.47	2.48	36.52	160	240	QP
304.79	28	48.57	46	-18	13.2	2.74	36.51	100	216	QP
435.61	30.63	46.55	46	-15.37	17.63	3.26	36.81	105	300	QP
504.92	27.79	42.78	46	-18.21	18.49	3.49	36.97	100	310	QP

REMARKS:

1. Emission level (dBuV/m) = Raw Value (dBuV) + Correction Factor (dB/m).
2. Correction Factor (dB/m) = Antenna Factor (dB/m) + Cable Factor (dB).
3. The other emission levels were very low against the limit.
4. Margin value = Emission level – Limit value.

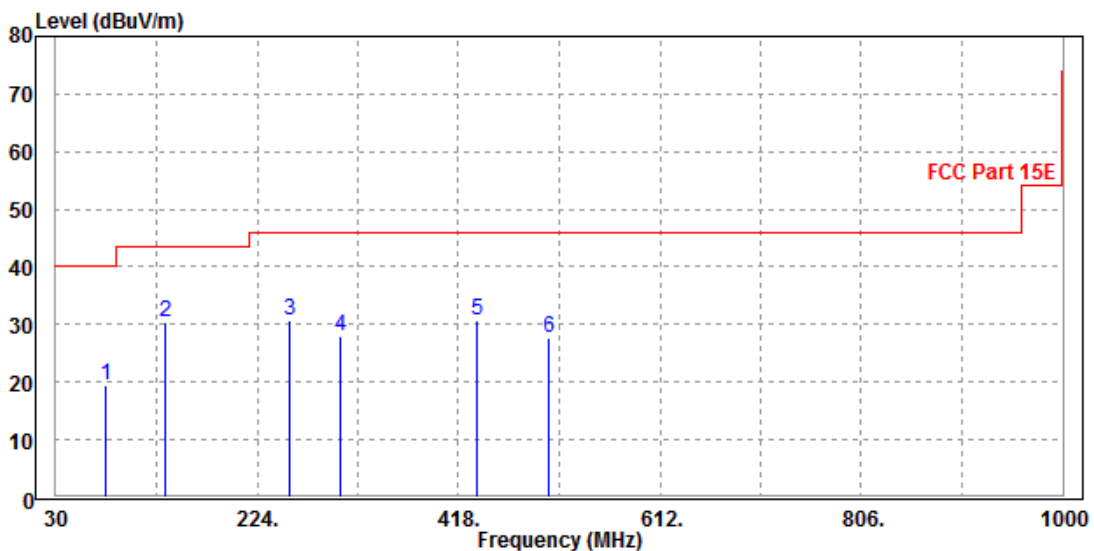



CHANNEL	Channel 110	DETECTOR FUNCTION	Quasi-Peak (QP)
FREQUENCY RANGE	30MHz ~ 1GHz		

ANTENNA POLARITY & TEST DISTANCE: VERTICAL AT 3 M										
FREQ. (MHz)	EMISSION LEVEL (dBuV/m)	READ LEVEL (dBuV)	LIMIT (dBuV/m)	MARGIN (dB)	ANTENNA FACTOR (dB /m)	CABLE LOSS (dB)	PREAMP FACTOR (dB)	ANTENNA HEIGHT (cm)	TABLE ANGLE (Degree)	REMARK
57.62	30.05	59.81	40	-9.95	6.42	1.15	37.33	104	112	QP
145.71	24.17	50.44	43.5	-19.33	8.69	1.85	36.81	110	206	QP
198.52	26.96	51.26	43.5	-16.54	10.09	2.16	36.55	105	250	QP
245.64	28.22	50.11	46	-17.78	12.2	2.43	36.52	113	270	QP
354.88	29.53	47.89	46	-16.47	15.3	2.96	36.62	140	270	QP
478.56	30.62	46	46	-15.38	18.14	3.39	36.91	100	230	QP

REMARKS:

1. Emission level (dBuV/m) = Raw Value (dBuV) + Correction Factor (dB/m).
2. Correction Factor (dB/m) = Antenna Factor (dB/m) + Cable Factor (dB).
3. The other emission levels were very low against the limit.
4. Margin value = Emission level – Limit value.

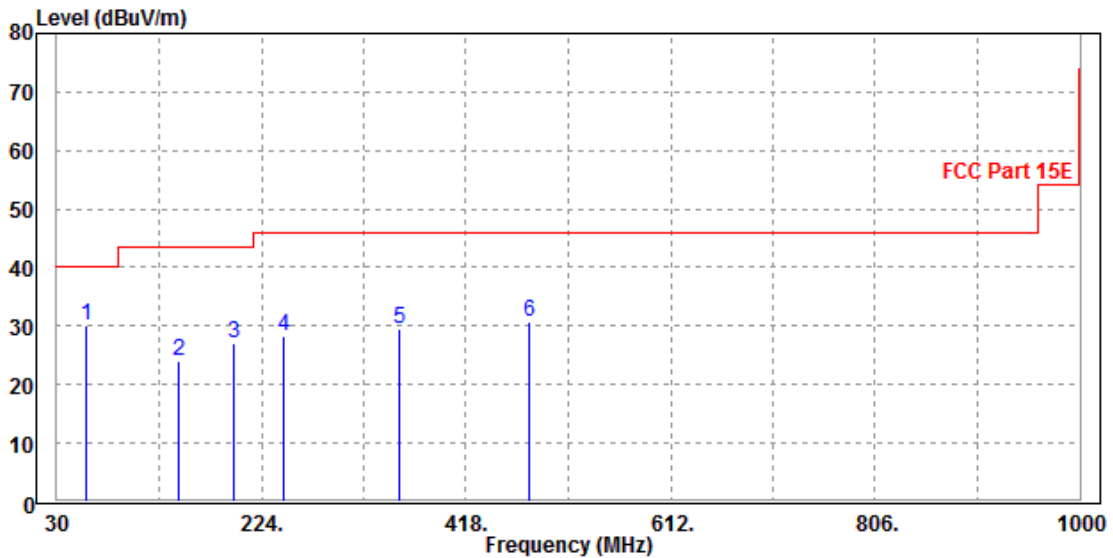



ABOVE 1GHz WORST-CASE DATA:

Note: For higher frequency, the emission is too low to be detected.

Band 1
802.11a

CHANNEL	TX Channel 36	DETECTOR FUNCTION	Peak (PK)
FREQUENCY RANGE	1GHz ~ 40GHz		Average (AV)

ANTENNA POLARITY & TEST DISTANCE: HORIZONTAL AT 3 M										
FREQ. (MHz)	EMISSION LEVEL (dBuV/m)	READ LEVEL (dBuV)	LIMIT (dBuV/m)	MARGIN (dB)	ANTENNA FACTOR (dB /m)	CABLE LOSS (dB)	PREAMP FACTOR (dB)	ANTENNA HEIGHT (cm)	TABLE ANGLE (Degree)	REMARK
5150	50.88	52.55	54	-3.12	37.26	7.42	46.35	100	158	Average
5150	58.48	60.15	74	-15.52	37.26	7.42	46.35	100	158	Peak
5180	96.73	98.38			37.27	7.43	46.35	100	158	Average
5180	107.15	108.8			37.27	7.43	46.35	100	158	Peak
5350	48.37	49.86	54	-5.63	37.34	7.47	46.3	100	158	Average
5350	58.32	59.81	74	-15.68	37.34	7.47	46.3	100	158	Peak

ANTENNA POLARITY & TEST DISTANCE: VERTICAL AT 3 M										
FREQ. (MHz)	EMISSION LEVEL (dBuV/m)	READ LEVEL (dBuV)	LIMIT (dBuV/m)	MARGIN (dB)	ANTENNA FACTOR (dB /m)	CABLE LOSS (dB)	PREAMP FACTOR (dB)	ANTENNA HEIGHT (cm)	TABLE ANGLE (Degree)	REMARK
5150	49.85	51.52	54	-4.15	37.26	7.42	46.35	100	158	Average
5150	58.79	60.46	74	-15.21	37.26	7.42	46.35	100	158	Peak
5180	89.98	91.63			37.27	7.43	46.35	100	158	Average
5180	99.99	101.64			37.27	7.43	46.35	100	158	Peak
5350	48.39	49.88	54	-5.61	37.34	7.47	46.3	100	158	Average
5350	57.92	59.41	74	-16.08	37.34	7.47	46.3	100	158	Peak

REMARKS:

- Emission Level = Read Level+ Antenna Factor + Cable Loss- Preamp Factor
Margin value = Emission level – Limit value.
- 5180MHz: Fundamental frequency.



CHANNEL	TX Channel 40	DETECTOR FUNCTION	Peak (PK)
FREQUENCY RANGE	1GHz ~ 40GHz		Average (AV)

ANTENNA POLARITY & TEST DISTANCE: HORIZONTAL AT 3 M										
FREQ. (MHz)	EMISSION LEVEL (dBuV/m)	READ LEVEL (dBuV)	LIMIT (dBuV/m)	MARGIN (dB)	ANTENNA FACTOR (dB /m)	CABLE LOSS (dB)	PREAMP FACTOR (dB)	ANTENNA HEIGHT (cm)	TABLE ANGLE (Degree)	REMARK
5150	50.51	52.18	54	-3.49	37.26	7.42	46.35	100	159	Average
5150	59.14	60.81	74	-14.86	37.26	7.42	46.35	100	159	Peak
5200	96.44	98.07			37.28	7.43	46.34	100	159	Average
5200	106.25	107.88			37.28	7.43	46.34	100	159	Peak
5350	48.42	49.91	54	-5.58	37.34	7.47	46.3	100	159	Average
5350	57.89	59.38	74	-16.11	37.34	7.47	46.3	100	159	Peak
ANTENNA POLARITY & TEST DISTANCE: VERTICAL AT 3 M										
FREQ. (MHz)	EMISSION LEVEL (dBuV/m)	READ LEVEL (dBuV)	LIMIT (dBuV/m)	MARGIN (dB)	ANTENNA FACTOR (dB /m)	CABLE LOSS (dB)	PREAMP FACTOR (dB)	ANTENNA HEIGHT (cm)	TABLE ANGLE (Degree)	REMARK
5150	50.17	51.84	54	-3.83	37.26	7.42	46.35	200	165	Average
5150	59.31	60.98	74	-14.69	37.26	7.42	46.35	200	165	Peak
5200	92.64	94.27			37.28	7.43	46.34	200	165	Average
5200	102.61	104.24			37.28	7.43	46.34	200	165	Peak
5350	48.43	49.92	54	-5.57	37.34	7.47	46.3	200	165	Average
5350	57.34	58.83	74	-16.66	37.34	7.47	46.3	200	165	Peak

REMARKS:

- Emission Level = Read Level+ Antenna Factor + Cable Loss- Preamp Factor
Margin value = Emission level – Limit value.
- 5200MHz: Fundamental frequency.



CHANNEL	TX Channel 48	DETECTOR FUNCTION	Peak (PK)
FREQUENCY RANGE	1GHz ~ 40GHz		Average (AV)

ANTENNA POLARITY & TEST DISTANCE: HORIZONTAL AT 3 M										
FREQ. (MHz)	EMISSION LEVEL (dBuV/m)	READ LEVEL (dBuV)	LIMIT (dBuV/m)	MARGIN (dB)	ANTENNA FACTOR (dB /m)	CABLE LOSS (dB)	PREAMP FACTOR (dB)	ANTENNA HEIGHT (cm)	TABLE ANGLE (Degree)	REMARK
5150	49.71	51.38	54	-4.29	37.26	7.42	46.35	100	156	Average
5150	58.36	60.03	74	-15.64	37.26	7.42	46.35	100	156	Peak
5240	96.42	98.01			37.3	7.44	46.33	100	156	Average
5240	106.4	107.99			37.3	7.44	46.33	100	156	Peak
5350	48.34	49.83	54	-5.66	37.34	7.47	46.3	100	156	Average
5350	55.12	56.61	74	-18.88	37.34	7.47	46.3	100	156	Peak
ANTENNA POLARITY & TEST DISTANCE: VERTICAL AT 3 M										
FREQ. (MHz)	EMISSION LEVEL (dBuV/m)	READ LEVEL (dBuV)	LIMIT (dBuV/m)	MARGIN (dB)	ANTENNA FACTOR (dB /m)	CABLE LOSS (dB)	PREAMP FACTOR (dB)	ANTENNA HEIGHT (cm)	TABLE ANGLE (Degree)	REMARK
5150	49.66	51.33	54	-4.34	37.26	7.42	46.35	100	220	Average
5150	58.76	60.43	74	-15.24	37.26	7.42	46.35	100	220	Peak
5240	94.5	96.09			37.3	7.44	46.33	100	220	Average
5240	105.1	106.69			37.3	7.44	46.33	100	220	Peak
5350	48.3	49.79	54	-5.7	37.34	7.47	46.3	100	220	Average
5350	57.66	59.15	74	-16.34	37.34	7.47	46.3	100	220	Peak

REMARKS:

- Emission Level = Read Level+ Antenna Factor + Cable Loss- Preamp Factor
Margin value = Emission level – Limit value.
- 5240MHz: Fundamental frequency.



802.11n (20MHz)

CHANNEL	TX Channel 36	DETECTOR FUNCTION	Peak (PK)
FREQUENCY RANGE	1GHz ~ 40GHz		Average (AV)

ANTENNA POLARITY & TEST DISTANCE: HORIZONTAL AT 3 M										
FREQ. (MHz)	EMISSION LEVEL (dBuV/m)	READ LEVEL (dBuV)	LIMIT (dBuV/m)	MARGIN (dB)	ANTENNA FACTOR (dB /m)	CABLE LOSS (dB)	PREAMP FACTOR (dB)	ANTENNA HEIGHT (cm)	TABLE ANGLE (Degree)	REMARK
5150	51.23	52.9	54	-2.77	37.26	7.42	46.35	100	160	Average
5150	59.32	60.99	74	-14.68	37.26	7.42	46.35	100	160	Peak
5180	96.57	98.22			37.27	7.43	46.35	100	160	Average
5180	106.63	108.28			37.27	7.43	46.35	100	160	Peak
5350	48.2	49.69	54	-5.8	37.34	7.47	46.3	100	160	Average
5350	58.16	59.65	74	-15.84	37.34	7.47	46.3	100	160	Peak

ANTENNA POLARITY & TEST DISTANCE: VERTICAL AT 3 M										
FREQ. (MHz)	EMISSION LEVEL (dBuV/m)	READ LEVEL (dBuV)	LIMIT (dBuV/m)	MARGIN (dB)	ANTENNA FACTOR (dB /m)	CABLE LOSS (dB)	PREAMP FACTOR (dB)	ANTENNA HEIGHT (cm)	TABLE ANGLE (Degree)	REMARK
5150	50.86	52.53	54	-3.14	37.26	7.42	46.35	176	166	Average
5150	60.17	61.84	74	-13.83	37.26	7.42	46.35	176	166	Peak
5180	95.47	97.12			37.27	7.43	46.35	176	166	Average
5180	105.17	106.82			37.27	7.43	46.35	176	166	Peak
5350	48.28	49.77	54	-5.72	37.34	7.47	46.3	176	166	Average
5350	57.55	59.04	74	-16.45	37.34	7.47	46.3	176	166	Peak

REMARKS:

- Emission Level = Read Level+ Antenna Factor + Cable Loss- Preamp Factor
Margin value = Emission level – Limit value.
- 5180MHz: Fundamental frequency.



CHANNEL	TX Channel 40	DETECTOR FUNCTION	Peak (PK)
FREQUENCY RANGE	1GHz ~ 40GHz		Average (AV)

ANTENNA POLARITY & TEST DISTANCE: HORIZONTAL AT 3 M

FREQ. (MHz)	EMISSION LEVEL (dBuV/m)	READ LEVEL (dBuV)	LIMIT (dBuV/m)	MARGIN (dB)	ANTENNA FACTOR (dB /m)	CABLE LOSS (dB)	PREAMP FACTOR (dB)	ANTENNA HEIGHT (cm)	TABLE ANGLE (Degree)	REMARK
5150	50.37	52.04	54	-3.63	37.26	7.42	46.35	100	164	Average
5150	58.65	60.32	74	-15.35	37.26	7.42	46.35	100	164	Peak
5200	95.25	96.88			37.28	7.43	46.34	100	164	Average
5200	105.55	107.18			37.28	7.43	46.34	100	164	Peak
5350	48.24	49.73	54	-5.76	37.34	7.47	46.3	100	164	Average
5350	57.57	59.06	74	-16.43	37.34	7.47	46.3	100	164	Peak

ANTENNA POLARITY & TEST DISTANCE: VERTICAL AT 3 M

FREQ. (MHz)	EMISSION LEVEL (dBuV/m)	READ LEVEL (dBuV)	LIMIT (dBuV/m)	MARGIN (dB)	ANTENNA FACTOR (dB /m)	CABLE LOSS (dB)	PREAMP FACTOR (dB)	ANTENNA HEIGHT (cm)	TABLE ANGLE (Degree)	REMARK
5150	50.52	52.19	54	-3.48	37.26	7.42	46.35	178	164	Average
5150	58.91	60.58	74	-15.09	37.26	7.42	46.35	178	164	Peak
5200	95.12	96.75			37.28	7.43	46.34	178	164	Average
5200	105.58	107.21			37.28	7.43	46.34	178	164	Peak
5350	48.25	49.74	54	-5.75	37.34	7.47	46.3	178	164	Average
5350	57.83	59.32	74	-16.17	37.34	7.47	46.3	178	164	Peak

REMARKS:

- Emission Level = Read Level+ Antenna Factor + Cable Loss- Preamp Factor
Margin value = Emission level – Limit value.
- 5200MHz: Fundamental frequency.



CHANNEL	TX Channel 48	DETECTOR FUNCTION	Peak (PK)
FREQUENCY RANGE	1GHz ~ 40GHz		Average (AV)

ANTENNA POLARITY & TEST DISTANCE: HORIZONTAL AT 3 M										
FREQ. (MHz)	EMISSION LEVEL (dBuV/m)	READ LEVEL (dBuV)	LIMIT (dBuV/m)	MARGIN (dB)	ANTENNA FACTOR (dB /m)	CABLE LOSS (dB)	PREAMP FACTOR (dB)	ANTENNA HEIGHT (cm)	TABLE ANGLE (Degree)	REMARK
5150	49.64	51.31	54	-4.36	37.26	7.42	46.35	100	168	Average
5150	59.55	61.22	74	-14.45	37.26	7.42	46.35	100	168	Peak
5240	94.69	96.28			37.3	7.44	46.33	100	168	Average
5240	105.09	106.68			37.3	7.44	46.33	100	168	Peak
5350	48.2	49.69	54	-5.8	37.34	7.47	46.3	100	168	Average
5350	58.04	59.53	74	-15.96	37.34	7.47	46.3	100	168	Peak

ANTENNA POLARITY & TEST DISTANCE: VERTICAL AT 3 M										
FREQ. (MHz)	EMISSION LEVEL (dBuV/m)	READ LEVEL (dBuV)	LIMIT (dBuV/m)	MARGIN (dB)	ANTENNA FACTOR (dB /m)	CABLE LOSS (dB)	PREAMP FACTOR (dB)	ANTENNA HEIGHT (cm)	TABLE ANGLE (Degree)	REMARK
5150	49.59	51.26	54	-4.41	37.26	7.42	46.35	100	117	Average
5150	58.4	60.07	74	-15.6	37.26	7.42	46.35	100	117	Peak
5240	92.52	94.11			37.3	7.44	46.33	100	117	Average
5240	103.39	104.98			37.3	7.44	46.33	100	117	Peak
5350	48.28	49.77	54	-5.72	37.34	7.47	46.3	100	117	Average
5350	58.62	60.11	74	-15.38	37.34	7.47	46.3	100	117	Peak

REMARKS:

- Emission Level = Read Level+ Antenna Factor + Cable Loss- Preamp Factor
Margin value = Emission level – Limit value.
- 5240MHz: Fundamental frequency.



802.11n (40MHz)

CHANNEL	TX Channel 38	DETECTOR FUNCTION	Peak (PK)
FREQUENCY RANGE	1GHz ~ 40GHz		Average (AV)

ANTENNA POLARITY & TEST DISTANCE: HORIZONTAL AT 3 M

FREQ. (MHz)	EMISSION LEVEL (dBuV/m)	READ LEVEL (dBuV)	LIMIT (dBuV/m)	MARGIN (dB)	ANTENNA FACTOR (dB /m)	CABLE LOSS (dB)	PREAMP FACTOR (dB)	ANTENNA HEIGHT (cm)	TABLE ANGLE (Degree)	REMARK
5150	51.4	53.07	54	-2.6	37.26	7.42	46.35	100	160	Average
5150	61.14	62.81	74	-12.86	37.26	7.42	46.35	100	160	Peak
5190	89.97	91.6			37.28	7.43	46.34	100	160	Average
5190	100.17	101.8			37.28	7.43	46.34	100	160	Peak
5350	48.2	49.69	54	-5.8	37.34	7.47	46.3	100	160	Average
5350	58.25	59.74	74	-15.75	37.34	7.47	46.3	100	160	Peak

ANTENNA POLARITY & TEST DISTANCE: VERTICAL AT 3 M

FREQ. (MHz)	EMISSION LEVEL (dBuV/m)	READ LEVEL (dBuV)	LIMIT (dBuV/m)	MARGIN (dB)	ANTENNA FACTOR (dB /m)	CABLE LOSS (dB)	PREAMP FACTOR (dB)	ANTENNA HEIGHT (cm)	TABLE ANGLE (Degree)	REMARK
5150	51.34	53.01	54	-2.66	37.26	7.42	46.35	100	185	Average
5150	50.31	51.98	54	-3.69	37.26	7.42	46.35	100	185	Average
5150	58.41	60.08			37.26	7.42	46.35	100	185	Peak
5190	86.22	87.85			37.28	7.43	46.34	100	185	Average
5190	95.58	97.21	74	21.58	37.28	7.43	46.34	100	185	Peak
5350	48.16	49.65	54	-5.84	37.34	7.47	46.3	100	185	Average

REMARKS:

- Emission Level = Read Level+ Antenna Factor + Cable Loss- Preamp Factor
Margin value = Emission level – Limit value.
- 5190MHz: Fundamental frequency.



CHANNEL	TX Channel 46	DETECTOR FUNCTION	Peak (PK)
FREQUENCY RANGE	1GHz ~ 40GHz		Average (AV)

ANTENNA POLARITY & TEST DISTANCE: HORIZONTAL AT 3 M

FREQ. (MHz)	EMISSION LEVEL (dBuV/m)	READ LEVEL (dBuV)	LIMIT (dBuV/m)	MARGIN (dB)	ANTENNA FACTOR (dB /m)	CABLE LOSS (dB)	PREAMP FACTOR (dB)	ANTENNA HEIGHT (cm)	TABLE ANGLE (Degree)	REMARK
5150	49.56	51.23	54	-4.44	37.26	7.42	46.35	100	177	Average
5150	58.36	60.03	74	-15.64	37.26	7.42	46.35	100	177	Peak
5230	88.83	90.43			37.29	7.44	46.33	100	177	Average
5230	98.35	99.95			37.29	7.44	46.33	100	177	Peak
5350	48.19	49.68	54	-5.81	37.34	7.47	46.3	100	177	Average
5350	57.64	59.13	74	-16.36	37.34	7.47	46.3	100	177	Peak

ANTENNA POLARITY & TEST DISTANCE: VERTICAL AT 3 M

FREQ. (MHz)	EMISSION LEVEL (dBuV/m)	READ LEVEL (dBuV)	LIMIT (dBuV/m)	MARGIN (dB)	ANTENNA FACTOR (dB /m)	CABLE LOSS (dB)	PREAMP FACTOR (dB)	ANTENNA HEIGHT (cm)	TABLE ANGLE (Degree)	REMARK
5150	49.52	51.19	54	-4.48	37.26	7.42	46.35	100	185	Average
5150	59.07	60.74	74	-14.93	37.26	7.42	46.35	100	185	Peak
5230	86.94	88.54			37.29	7.44	46.33	100	185	Average
5230	96.62	98.22			37.29	7.44	46.33	100	185	Peak
5350	48.03	49.52	54	-5.97	37.34	7.47	46.3	100	185	Average
5350	57.16	58.65	74	-16.84	37.34	7.47	46.3	100	185	Peak

REMARKS:

1. Emission Level = Read Level+ Antenna Factor + Cable Loss- Preamp Factor
Margin value = Emission level – Limit value.
2. 5230MHz: Fundamental frequency.



**Band 2
802.11a**

CHANNEL	TX Channel 52	DETECTOR FUNCTION	Peak (PK)
FREQUENCY RANGE	1GHz ~ 40GHz		Average (AV)

ANTENNA POLARITY & TEST DISTANCE: HORIZONTAL AT 3 M

FREQ. (MHz)	EMISSION LEVEL (dBuV/m)	READ LEVEL (dBuV)	LIMIT (dBuV/m)	MARGIN (dB)	ANTENNA FACTOR (dB /m)	CABLE LOSS (dB)	PREAMP FACTOR (dB)	ANTENNA HEIGHT (cm)	TABLE ANGLE (Degree)	REMARK
5150	49.55	51.22	54	-4.45	37.26	7.42	46.35	100	162	Average
5150	58.71	60.38	74	-15.29	37.26	7.42	46.35	100	162	Peak
5260	94.47	96.04			37.3	7.45	46.32	100	162	Average
5260	103.44	105.01			37.3	7.45	46.32	100	162	Peak
5350	48.23	49.72	54	-5.77	37.34	7.47	46.3	100	162	Average
5350	56.98	58.47	74	-17.02	37.34	7.47	46.3	100	162	Peak

ANTENNA POLARITY & TEST DISTANCE: VERTICAL AT 3 M

FREQ. (MHz)	EMISSION LEVEL (dBuV/m)	READ LEVEL (dBuV)	LIMIT (dBuV/m)	MARGIN (dB)	ANTENNA FACTOR (dB /m)	CABLE LOSS (dB)	PREAMP FACTOR (dB)	ANTENNA HEIGHT (cm)	TABLE ANGLE (Degree)	REMARK
5150	49.54	51.21	54	-4.46	37.26	7.42	46.35	100	123	Average
5150	57.85	59.52	74	-16.15	37.26	7.42	46.35	100	123	Peak
5260	93.44	95.01			37.3	7.45	46.32	100	123	Average
5260	104.05	105.62			37.3	7.45	46.32	100	123	Peak
5350	48.16	49.65	54	-5.84	37.34	7.47	46.3	100	123	Average
5350	57.82	59.31	74	-16.18	37.34	7.47	46.3	100	123	Peak

REMARKS:

- Emission Level = Read Level+ Antenna Factor + Cable Loss- Preamp Factor
Margin value = Emission level – Limit value.
- 5260MHz: Fundamental frequency.



CHANNEL	TX Channel 60	DETECTOR FUNCTION	Peak (PK)
FREQUENCY RANGE	1GHz ~ 40GHz		Average (AV)

ANTENNA POLARITY & TEST DISTANCE: HORIZONTAL AT 3 M										
FREQ. (MHz)	EMISSION LEVEL (dBuV/m)	READ LEVEL (dBuV)	LIMIT (dBuV/m)	MARGIN (dB)	ANTENNA FACTOR (dB /m)	CABLE LOSS (dB)	PREAMP FACTOR (dB)	ANTENNA HEIGHT (cm)	TABLE ANGLE (Degree)	REMARK
5150	49.6	51.27	54	-4.4	37.26	7.42	46.35	116	164	Average
5150	58.44	60.11	74	-15.56	37.26	7.42	46.35	116	164	Peak
5300	96.3	97.83			37.32	7.46	46.31	116	164	Average
5300	106.39	107.92			37.32	7.46	46.31	116	164	Peak
5350	49.43	50.92	54	-4.57	37.34	7.47	46.3	116	164	Average
5350	57.64	59.13	74	-16.36	37.34	7.47	46.3	116	164	Peak

ANTENNA POLARITY & TEST DISTANCE: VERTICAL AT 3 M										
FREQ. (MHz)	EMISSION LEVEL (dBuV/m)	READ LEVEL (dBuV)	LIMIT (dBuV/m)	MARGIN (dB)	ANTENNA FACTOR (dB /m)	CABLE LOSS (dB)	PREAMP FACTOR (dB)	ANTENNA HEIGHT (cm)	TABLE ANGLE (Degree)	REMARK
5150	49.57	51.24	54	-4.43	37.26	7.42	46.35	100	240	Average
5150	58.42	60.09	74	-15.58	37.26	7.42	46.35	100	240	Peak
5300	94.26	95.79			37.32	7.46	46.31	100	240	Average
5300	104.29	105.82			37.32	7.46	46.31	100	240	Peak
5350	49.2	50.69	54	-4.8	37.34	7.47	46.3	100	240	Average
5350	57.69	59.18	74	-16.31	37.34	7.47	46.3	100	240	Peak

REMARKS:

- Emission Level = Read Level+ Antenna Factor + Cable Loss- Preamp Factor
Margin value = Emission level – Limit value.
- 5300MHz: Fundamental frequency.



CHANNEL	TX Channel 64	DETECTOR FUNCTION	Peak (PK)
FREQUENCY RANGE	1GHz ~ 40GHz		Average (AV)

ANTENNA POLARITY & TEST DISTANCE: HORIZONTAL AT 3 M										
FREQ. (MHz)	EMISSION LEVEL (dBuV/m)	READ LEVEL (dBuV)	LIMIT (dBuV/m)	MARGIN (dB)	ANTENNA FACTOR (dB /m)	CABLE LOSS (dB)	PREAMP FACTOR (dB)	ANTENNA HEIGHT (cm)	TABLE ANGLE (Degree)	REMARK
5150	49.6	51.27	54	-4.4	37.26	7.42	46.35	100	159	Average
5150	59.01	60.68	74	-14.99	37.26	7.42	46.35	100	159	Peak
5320	95.4	96.91			37.33	7.46	46.3	100	159	Average
5320	106.09	107.6			37.33	7.46	46.3	100	159	Peak
5350	50.34	51.83	54	-3.66	37.34	7.47	46.3	100	159	Average
5350	58.49	59.98	74	-15.51	37.34	7.47	46.3	100	159	Peak

ANTENNA POLARITY & TEST DISTANCE: VERTICAL AT 3 M										
FREQ. (MHz)	EMISSION LEVEL (dBuV/m)	READ LEVEL (dBuV)	LIMIT (dBuV/m)	MARGIN (dB)	ANTENNA FACTOR (dB /m)	CABLE LOSS (dB)	PREAMP FACTOR (dB)	ANTENNA HEIGHT (cm)	TABLE ANGLE (Degree)	REMARK
5150	49.64	51.31	54	-4.36	37.26	7.42	46.35	100	236	Average
5150	59.15	60.82	74	-14.85	37.26	7.42	46.35	100	236	Peak
5320	95.32	96.83			37.33	7.46	46.3	100	236	Average
5320	105.29	106.8			37.33	7.46	46.3	100	236	Peak
5350	50.74	52.23	54	-3.26	37.34	7.47	46.3	100	236	Average
5350	59.62	61.11	74	-14.38	37.34	7.47	46.3	100	236	Peak

REMARKS:

- Emission Level = Read Level+ Antenna Factor + Cable Loss- Preamp Factor
Margin value = Emission level – Limit value.
- 5320MHz: Fundamental frequency.



802.11n (20MHz)

CHANNEL	TX Channel 52	DETECTOR FUNCTION	Peak (PK)
FREQUENCY RANGE	1GHz ~ 40GHz		Average (AV)

ANTENNA POLARITY & TEST DISTANCE: HORIZONTAL AT 3 M										
FREQ. (MHz)	EMISSION LEVEL (dBuV/m)	READ LEVEL (dBuV)	LIMIT (dBuV/m)	MARGIN (dB)	ANTENNA FACTOR (dB /m)	CABLE LOSS (dB)	PREAMP FACTOR (dB)	ANTENNA HEIGHT (cm)	TABLE ANGLE (Degree)	REMARK
5150	49.5	51.17	54	-4.5	37.26	7.42	46.35	138	168	Average
5150	59.28	60.95	74	-14.72	37.26	7.42	46.35	138	168	Peak
5260	96.85	98.42			37.3	7.45	46.32	138	168	Average
5260	107.69	109.26			37.3	7.45	46.32	138	168	Peak
5350	48.24	49.73	54	-5.76	37.34	7.47	46.3	138	168	Average
5350	56.95	58.44	74	-17.05	37.34	7.47	46.3	138	168	Peak

ANTENNA POLARITY & TEST DISTANCE: VERTICAL AT 3 M										
FREQ. (MHz)	EMISSION LEVEL (dBuV/m)	READ LEVEL (dBuV)	LIMIT (dBuV/m)	MARGIN (dB)	ANTENNA FACTOR (dB /m)	CABLE LOSS (dB)	PREAMP FACTOR (dB)	ANTENNA HEIGHT (cm)	TABLE ANGLE (Degree)	REMARK
5150	49.45	51.12	54	-4.55	37.26	7.42	46.35	144	168	Average
5150	58.16	59.83	74	-15.84	37.26	7.42	46.35	144	168	Peak
5260	96.75	98.32			37.3	7.45	46.32	144	168	Average
5260	106.49	108.06			37.3	7.45	46.32	144	168	Peak
5350	48.2	49.69	54	-5.8	37.34	7.47	46.3	144	168	Average
5350	56.93	58.42	74	-17.07	37.34	7.47	46.3	144	168	Peak

REMARKS:

- Emission Level = Read Level+ Antenna Factor + Cable Loss- Preamp Factor
Margin value = Emission level – Limit value.
- 5260MHz: Fundamental frequency.



CHANNEL	TX Channel 60	DETECTOR FUNCTION	Peak (PK)
FREQUENCY RANGE	1GHz ~ 40GHz		Average (AV)

ANTENNA POLARITY & TEST DISTANCE: HORIZONTAL AT 3 M										
FREQ. (MHz)	EMISSION LEVEL (dBuV/m)	READ LEVEL (dBuV)	LIMIT (dBuV/m)	MARGIN (dB)	ANTENNA FACTOR (dB /m)	CABLE LOSS (dB)	PREAMP FACTOR (dB)	ANTENNA HEIGHT (cm)	TABLE ANGLE (Degree)	REMARK
5150	49.55	51.22	54	-4.45	37.26	7.42	46.35	121	166	Average
5150	58.69	60.36	74	-15.31	37.26	7.42	46.35	121	166	Peak
5300	96.88	98.41			37.32	7.46	46.31	121	166	Average
5300	107.62	109.15			37.32	7.46	46.31	121	166	Peak
5350	49.77	51.26	54	-4.23	37.34	7.47	46.3	121	166	Average
5350	58.16	59.65	74	-15.84	37.34	7.47	46.3	121	166	Peak

ANTENNA POLARITY & TEST DISTANCE: VERTICAL AT 3 M										
FREQ. (MHz)	EMISSION LEVEL (dBuV/m)	READ LEVEL (dBuV)	LIMIT (dBuV/m)	MARGIN (dB)	ANTENNA FACTOR (dB /m)	CABLE LOSS (dB)	PREAMP FACTOR (dB)	ANTENNA HEIGHT (cm)	TABLE ANGLE (Degree)	REMARK
5150	49.51	51.18	54	-4.49	37.26	7.42	46.35	100	235	Average
5150	59.31	60.98	74	-14.69	37.26	7.42	46.35	100	235	Peak
5300	94.68	96.21			37.32	7.46	46.31	100	235	Average
5300	104.4	105.93			37.32	7.46	46.31	100	235	Peak
5350	49.22	50.71	54	-4.78	37.34	7.47	46.3	100	235	Average
5350	58.16	59.65	74	-15.84	37.34	7.47	46.3	100	235	Peak

REMARKS:

- Emission Level = Read Level+ Antenna Factor + Cable Loss- Preamp Factor
Margin value = Emission level – Limit value.
- 5300MHz: Fundamental frequency.



CHANNEL	TX Channel 64	DETECTOR FUNCTION	Peak (PK)
FREQUENCY RANGE	1GHz ~ 40GHz		Average (AV)

ANTENNA POLARITY & TEST DISTANCE: HORIZONTAL AT 3 M										
FREQ. (MHz)	EMISSION LEVEL (dBuV/m)	READ LEVEL (dBuV)	LIMIT (dBuV/m)	MARGIN (dB)	ANTENNA FACTOR (dB /m)	CABLE LOSS (dB)	PREAMP FACTOR (dB)	ANTENNA HEIGHT (cm)	TABLE ANGLE (Degree)	REMARK
5150	49.54	51.21	54	-4.46	37.26	7.42	46.35	151	167	Average
5150	58.62	60.29	74	-15.38	37.26	7.42	46.35	151	167	Peak
5320	96	97.51			37.33	7.46	46.3	151	167	Average
5320	105.89	107.4			37.33	7.46	46.3	151	167	Peak
5350	51.55	53.04	54	-2.45	37.34	7.47	46.3	151	167	Average
5350	61.54	63.03	74	-12.46	37.34	7.47	46.3	151	167	Peak

ANTENNA POLARITY & TEST DISTANCE: VERTICAL AT 3 M										
FREQ. (MHz)	EMISSION LEVEL (dBuV/m)	READ LEVEL (dBuV)	LIMIT (dBuV/m)	MARGIN (dB)	ANTENNA FACTOR (dB /m)	CABLE LOSS (dB)	PREAMP FACTOR (dB)	ANTENNA HEIGHT (cm)	TABLE ANGLE (Degree)	REMARK
5150	49.54	51.21	54	-4.46	37.26	7.42	46.35	100	229	Average
5150	58.14	59.81	74	-15.86	37.26	7.42	46.35	100	229	Peak
5320	94.39	95.9			37.33	7.46	46.3	100	229	Average
5320	104.3	105.81			37.33	7.46	46.3	100	229	Peak
5350	50.52	52.01	54	-3.48	37.34	7.47	46.3	100	229	Average
5350	59.52	61.01	74	-14.48	37.34	7.47	46.3	100	229	Peak

REMARKS:

1. Emission Level = Read Level+ Antenna Factor + Cable Loss- Preamp Factor
Margin value = Emission level – Limit value.
2. 5320MHz: Fundamental frequency.



802.11n (40MHz)

CHANNEL	TX Channel 54	DETECTOR FUNCTION	Peak (PK)
FREQUENCY RANGE	1GHz ~ 40GHz		Average (AV)

ANTENNA POLARITY & TEST DISTANCE: HORIZONTAL AT 3 M										
FREQ. (MHz)	EMISSION LEVEL (dBuV/m)	READ LEVEL (dBuV)	LIMIT (dBuV/m)	MARGIN (dB)	ANTENNA FACTOR (dB /m)	CABLE LOSS (dB)	PREAMP FACTOR (dB)	ANTENNA HEIGHT (cm)	TABLE ANGLE (Degree)	REMARK
5150	49.45	51.12	54	-4.55	37.26	7.42	46.35	105	162	Average
5150	58.07	59.74	74	-15.93	37.26	7.42	46.35	105	162	Peak
5270	91.25	92.81			37.31	7.45	46.32	105	162	Average
5270	99.48	101.04			37.31	7.45	46.32	105	162	Peak
5350	48.23	49.72	54	-5.77	37.34	7.47	46.3	105	162	Average
5350	57.28	58.77	74	-16.72	37.34	7.47	46.3	105	162	Peak

ANTENNA POLARITY & TEST DISTANCE: VERTICAL AT 3 M										
FREQ. (MHz)	EMISSION LEVEL (dBuV/m)	READ LEVEL (dBuV)	LIMIT (dBuV/m)	MARGIN (dB)	ANTENNA FACTOR (dB /m)	CABLE LOSS (dB)	PREAMP FACTOR (dB)	ANTENNA HEIGHT (cm)	TABLE ANGLE (Degree)	REMARK
5150	49.35	51.02	54	-4.65	37.26	7.42	46.35	100	225	Average
5150	58.51	60.18	74	-15.49	37.26	7.42	46.35	100	225	Peak
5270	87.6	89.16			37.31	7.45	46.32	100	225	Average
5270	97.32	98.88			37.31	7.45	46.32	100	225	Peak
5350	48.04	49.53	54	-5.96	37.34	7.47	46.3	100	225	Average
5350	57.05	58.54	74	-16.95	37.34	7.47	46.3	100	225	Peak

REMARKS:

- Emission Level = Read Level+ Antenna Factor + Cable Loss- Preamp Factor
Margin value = Emission level – Limit value.
- 5270MHz: Fundamental frequency.



CHANNEL	TX Channel 62	DETECTOR FUNCTION	Peak (PK)
FREQUENCY RANGE	1GHz ~ 40GHz		Average (AV)

ANTENNA POLARITY & TEST DISTANCE: HORIZONTAL AT 3 M										
FREQ. (MHz)	EMISSION LEVEL (dBuV/m)	READ LEVEL (dBuV)	LIMIT (dBuV/m)	MARGIN (dB)	ANTENNA FACTOR (dB /m)	CABLE LOSS (dB)	PREAMP FACTOR (dB)	ANTENNA HEIGHT (cm)	TABLE ANGLE (Degree)	REMARK
5150	49.47	51.14	54	-4.53	37.26	7.42	46.35	100	211	Average
5150	59.44	61.11	74	-14.56	37.26	7.42	46.35	100	211	Peak
5310	87.19	88.72			37.32	7.46	46.31	100	211	Average
5310	98.36	99.89			37.32	7.46	46.31	100	211	Peak
5350	50.64	52.13	54	-3.36	37.34	7.47	46.3	100	211	Average
5350	60.17	61.66	74	-13.83	37.34	7.47	46.3	100	211	Peak

ANTENNA POLARITY & TEST DISTANCE: VERTICAL AT 3 M										
FREQ. (MHz)	EMISSION LEVEL (dBuV/m)	READ LEVEL (dBuV)	LIMIT (dBuV/m)	MARGIN (dB)	ANTENNA FACTOR (dB /m)	CABLE LOSS (dB)	PREAMP FACTOR (dB)	ANTENNA HEIGHT (cm)	TABLE ANGLE (Degree)	REMARK
5150	49.39	51.06	54	-4.61	37.26	7.42	46.35	100	231	Average
5150	58.99	60.66	74	-15.01	37.26	7.42	46.35	100	231	Peak
5310	88.17	89.7			37.32	7.46	46.31	100	231	Average
5310	97.14	98.67			37.32	7.46	46.31	100	231	Peak
5350	51.03	52.52	54	-2.97	37.34	7.47	46.3	100	231	Average
5350	60.48	61.97	74	-13.52	37.34	7.47	46.3	100	231	Peak

REMARKS:

- Emission Level = Read Level+ Antenna Factor + Cable Loss- Preamp Factor
Margin value = Emission level – Limit value.
- 5310MHz: Fundamental frequency.



Band 3

802.11a

CHANNEL	TX Channel 100	DETECTOR FUNCTION	Peak (PK)
FREQUENCY RANGE	1GHz ~ 40GHz		Average (AV)

ANTENNA POLARITY & TEST DISTANCE: HORIZONTAL AT 3 M

FREQ. (MHz)	EMISSION LEVEL (dBuV/m)	READ LEVEL (dBuV)	LIMIT (dBuV/m)	MARGIN (dB)	ANTENNA FACTOR (dB /m)	CABLE LOSS (dB)	PREAMP FACTOR (dB)	ANTENNA HEIGHT (cm)	TABLE ANGLE (Degree)	REMARK
5460	49.07	50.46	54	-4.93	37.38	7.49	46.26	100	184	Average
5460	57.76	59.15	74	-16.24	37.38	7.49	46.26	100	184	Peak
#5470	60.89	62.27	68	-7.41	37.39	7.49	46.26	100	184	Peak
5500	96.9	98.25			37.4	7.5	46.25	100	184	Average
5500	106.74	108.09			37.4	7.5	46.25	100	184	Peak

ANTENNA POLARITY & TEST DISTANCE: VERTICAL AT 3 M

FREQ. (MHz)	EMISSION LEVEL (dBuV/m)	READ LEVEL (dBuV)	LIMIT (dBuV/m)	MARGIN (dB)	ANTENNA FACTOR (dB /m)	CABLE LOSS (dB)	PREAMP FACTOR (dB)	ANTENNA HEIGHT (cm)	TABLE ANGLE (Degree)	REMARK
5460	48.65	50.04	54	-5.35	37.38	7.49	46.26	100	160	Average
5460	57.6	58.99	74	-16.4	37.38	7.49	46.26	100	160	Peak
#5470	62.59	63.97	68.3	-5.71	37.39	7.49	46.26	100	160	Peak
5500	95.77	97.12			37.4	7.5	46.25	100	160	Average
5500	106.16	107.51			37.4	7.5	46.25	100	160	Peak

REMARKS:

- Emission Level = Read Level+ Antenna Factor + Cable Loss- Preamp Factor
Margin value = Emission level – Limit value.
- 5500MHz: Fundamental frequency.
- #: Out of restricted band.



CHANNEL	TX Channel 116	DETECTOR FUNCTION	Peak (PK)
FREQUENCY RANGE	1GHz ~ 40GHz		Average (AV)

ANTENNA POLARITY & TEST DISTANCE: HORIZONTAL AT 3 M										
FREQ. (MHz)	EMISSION LEVEL (dBuV/m)	READ LEVEL (dBuV)	LIMIT (dBuV/m)	MARGIN (dB)	ANTENNA FACTOR (dB /m)	CABLE LOSS (dB)	PREAMP FACTOR (dB)	ANTENNA HEIGHT (cm)	TABLE ANGLE (Degree)	REMARK
5460	47.63	49.02	54	-6.37	37.38	7.49	46.26	124	187	Average
5460	56.72	58.11	74	-17.28	37.38	7.49	46.26	124	187	Peak
#5470	57.18	58.56	68.3	-11.12	37.39	7.49	46.26	124	187	Peak
5580	97.39	98.59			37.45	7.58	46.23	124	187	Average
5580	106.59	107.79			37.45	7.58	46.23	124	187	Peak

ANTENNA POLARITY & TEST DISTANCE: VERTICAL AT 3 M										
FREQ. (MHz)	EMISSION LEVEL (dBuV/m)	READ LEVEL (dBuV)	LIMIT (dBuV/m)	MARGIN (dB)	ANTENNA FACTOR (dB /m)	CABLE LOSS (dB)	PREAMP FACTOR (dB)	ANTENNA HEIGHT (cm)	TABLE ANGLE (Degree)	REMARK
5460	47.67	49.06	54	-6.33	37.38	7.49	46.26	151	166	Average
5460	57.88	59.27	74	-16.12	37.38	7.49	46.26	151	166	Peak
#5470	57.36	58.74	68.3	-10.94	37.39	7.49	46.26	151	166	Peak
5580	97.81	99.01			37.45	7.58	46.23	151	166	Average
5580	105.88	107.08			37.45	7.58	46.23	151	166	Peak

REMARKS:

- Emission Level = Read Level+ Antenna Factor + Cable Loss- Preamp Factor
Margin value = Emission level – Limit value.
- 5580MHz: Fundamental frequency.
- #: Out of restricted band.



CHANNEL	TX Channel 140	DETECTOR FUNCTION	Peak (PK)
FREQUENCY RANGE	1GHz ~ 40GHz		Average (AV)

ANTENNA POLARITY & TEST DISTANCE: HORIZONTAL AT 3 M										
FREQ. (MHz)	EMISSION LEVEL (dBuV/m)	READ LEVEL (dBuV)	LIMIT (dBuV/m)	MARGIN (dB)	ANTENNA FACTOR (dB /m)	CABLE LOSS (dB)	PREAMP FACTOR (dB)	ANTENNA HEIGHT (cm)	TABLE ANGLE (Degree)	REMARK
5700	97.49	98.46			37.52	7.7	46.19	115	164	Average
5700	107.09	108.06			37.52	7.7	46.19	115	164	Peak
#5725	64	64.93	68.3	-4.3	37.53	7.73	46.19	115	164	Peak
ANTENNA POLARITY & TEST DISTANCE: VERTICAL AT 3 M										
FREQ. (MHz)	EMISSION LEVEL (dBuV/m)	READ LEVEL (dBuV)	LIMIT (dBuV/m)	MARGIN (dB)	ANTENNA FACTOR (dB /m)	CABLE LOSS (dB)	PREAMP FACTOR (dB)	ANTENNA HEIGHT (cm)	TABLE ANGLE (Degree)	REMARK
5700	93.84	94.81			37.52	7.7	46.19	100	0	Average
5700	104.09	105.06			37.52	7.7	46.19	100	0	Peak
#5725	66.18	67.11	68.3	-2.12	37.53	7.73	46.19	100	0	Peak

REMARKS:

- Emission Level = Read Level+ Antenna Factor + Cable Loss- Preamp Factor
Margin value = Emission level – Limit value.
- 5700MHz: Fundamental frequency.
- #: Out of restricted band.



802.11n (20MHz)

CHANNEL	TX Channel 100	DETECTOR FUNCTION	Peak (PK)
FREQUENCY RANGE	1GHz ~ 40GHz		Average (AV)

ANTENNA POLARITY & TEST DISTANCE: HORIZONTAL AT 3 M										
FREQ. (MHz)	EMISSION LEVEL (dBuV/m)	READ LEVEL (dBuV)	LIMIT (dBuV/m)	MARGIN (dB)	ANTENNA FACTOR (dB /m)	CABLE LOSS (dB)	PREAMP FACTOR (dB)	ANTENNA HEIGHT (cm)	TABLE ANGLE (Degree)	REMARK
5460	50.22	51.61	54	-3.78	37.38	7.49	46.26	100	167	Average
5460	58.84	60.23	74	-15.16	37.38	7.49	46.26	100	167	Peak
#5470	63.7	65.08	68.3	-4.6	37.39	7.49	46.26	100	167	Peak
5500	97.97	99.32			37.4	7.5	46.25	100	167	Average
5500	107.26	108.61			37.4	7.5	46.25	100	167	Peak

ANTENNA POLARITY & TEST DISTANCE: VERTICAL AT 3 M										
FREQ. (MHz)	EMISSION LEVEL (dBuV/m)	READ LEVEL (dBuV)	LIMIT (dBuV/m)	MARGIN (dB)	ANTENNA FACTOR (dB /m)	CABLE LOSS (dB)	PREAMP FACTOR (dB)	ANTENNA HEIGHT (cm)	TABLE ANGLE (Degree)	REMARK
5460	48.73	50.12	54	-5.27	37.38	7.49	46.26	100	164	Average
5460	57.09	58.48	74	-16.91	37.38	7.49	46.26	100	164	Peak
#5470	58.55	59.93	68.3	-9.75	37.39	7.49	46.26	100	164	Peak
5500	94.63	95.98			37.4	7.5	46.25	100	164	Average
5500	105.5	106.85			37.4	7.5	46.25	100	164	Peak

REMARKS:

- Emission Level = Read Level+ Antenna Factor + Cable Loss- Preamp Factor
Margin value = Emission level – Limit value.
- 5500MHz: Fundamental frequency.
- #: Out of restricted band.



CHANNEL	TX Channel 116	DETECTOR FUNCTION	Peak (PK)
FREQUENCY RANGE	1GHz ~ 40GHz		Average (AV)

ANTENNA POLARITY & TEST DISTANCE: HORIZONTAL AT 3 M										
FREQ. (MHz)	EMISSION LEVEL (dBuV/m)	READ LEVEL (dBuV)	LIMIT (dBuV/m)	MARGIN (dB)	ANTENNA FACTOR (dB /m)	CABLE LOSS (dB)	PREAMP FACTOR (dB)	ANTENNA HEIGHT (cm)	TABLE ANGLE (Degree)	REMARK
5460	47.62	49.01	54	-6.38	37.38	7.49	46.26	100	162	Average
5460	58.25	59.64	74	-15.75	37.38	7.49	46.26	100	162	Peak
#5470	58.16	59.54	68.3	-10.14	37.39	7.49	46.26	100	162	Peak
5580	96.99	98.19			37.45	7.58	46.23	100	162	Average
5580	107.98	109.18			37.45	7.58	46.23	100	162	Peak

ANTENNA POLARITY & TEST DISTANCE: VERTICAL AT 3 M										
FREQ. (MHz)	EMISSION LEVEL (dBuV/m)	READ LEVEL (dBuV)	LIMIT (dBuV/m)	MARGIN (dB)	ANTENNA FACTOR (dB /m)	CABLE LOSS (dB)	PREAMP FACTOR (dB)	ANTENNA HEIGHT (cm)	TABLE ANGLE (Degree)	REMARK
5460	47.65	49.04	54	-6.35	37.38	7.49	46.26	145	168	Average
5460	57.14	58.53	74	-16.86	37.38	7.49	46.26	145	168	Peak
#5470	56.8	58.18	68.3	-11.5	37.39	7.49	46.26	145	168	Peak
5580	98.59	99.79			37.45	7.58	46.23	145	168	Average
5580	107.94	109.14			37.45	7.58	46.23	145	168	Peak

REMARKS:

- Emission Level = Read Level+ Antenna Factor + Cable Loss- Preamp Factor
Margin value = Emission level – Limit value.
- 5580MHz: Fundamental frequency.



CHANNEL	TX Channel 140	DETECTOR FUNCTION	Peak (PK)
FREQUENCY RANGE	1GHz ~ 40GHz		Average (AV)

ANTENNA POLARITY & TEST DISTANCE: HORIZONTAL AT 3 M										
FREQ. (MHz)	EMISSION LEVEL (dBuV/m)	READ LEVEL (dBuV)	LIMIT (dBuV/m)	MARGIN (dB)	ANTENNA FACTOR (dB /m)	CABLE LOSS (dB)	PREAMP FACTOR (dB)	ANTENNA HEIGHT (cm)	TABLE ANGLE (Degree)	REMARK
5700	96.94	97.91			37.52	7.7	46.19	122	166	Average
5700	108.02	108.99			37.52	7.7	46.19	122	166	Peak
#5725	65.83	66.76	68.3	-2.47	37.53	7.73	46.19	122	166	Peak
ANTENNA POLARITY & TEST DISTANCE: VERTICAL AT 3 M										
FREQ. (MHz)	EMISSION LEVEL (dBuV/m)	READ LEVEL (dBuV)	LIMIT (dBuV/m)	MARGIN (dB)	ANTENNA FACTOR (dB /m)	CABLE LOSS (dB)	PREAMP FACTOR (dB)	ANTENNA HEIGHT (cm)	TABLE ANGLE (Degree)	REMARK
5700	96.17	97.14			37.52	7.7	46.19	100	173	Average
5700	106.04	107.01			37.52	7.7	46.19	100	173	Peak
#5725	66.33	67.26	68.3	-1.97	37.53	7.73	46.19	100	173	Peak

REMARKS:

- Emission Level = Read Level+ Antenna Factor + Cable Loss- Preamp Factor
Margin value = Emission level – Limit value.
- 5700MHz: Fundamental frequency.
- #: Out of restricted band.



802.11n (40MHz)

CHANNEL	TX Channel 102	DETECTOR FUNCTION	Peak (PK)
FREQUENCY RANGE	1GHz ~ 40GHz		Average (AV)

ANTENNA POLARITY & TEST DISTANCE: HORIZONTAL AT 3 M										
FREQ. (MHz)	EMISSION LEVEL (dBuV/m)	READ LEVEL (dBuV)	LIMIT (dBuV/m)	MARGIN (dB)	ANTENNA FACTOR (dB /m)	CABLE LOSS (dB)	PREAMP FACTOR (dB)	ANTENNA HEIGHT (cm)	TABLE ANGLE (Degree)	REMARK
5460	50.28	51.67	54	-3.72	37.38	7.49	46.26	100	165	Average
5460	57.47	58.86	74	-16.53	37.38	7.49	46.26	100	165	Peak
#5470	65.19	66.57	68.3	-3.11	37.39	7.49	46.26	100	165	Peak
5510	92.9	94.23			37.41	7.51	46.25	100	165	Average
5510	101.96	103.29			37.41	7.51	46.25	100	165	Peak

ANTENNA POLARITY & TEST DISTANCE: VERTICAL AT 3 M										
FREQ. (MHz)	EMISSION LEVEL (dBuV/m)	READ LEVEL (dBuV)	LIMIT (dBuV/m)	MARGIN (dB)	ANTENNA FACTOR (dB /m)	CABLE LOSS (dB)	PREAMP FACTOR (dB)	ANTENNA HEIGHT (cm)	TABLE ANGLE (Degree)	REMARK
5460	49.28	50.67	54	-4.72	37.38	7.49	46.26	100	168	Average
5460	57.29	58.68	74	-16.71	37.38	7.49	46.26	100	168	Peak
#5470	64.65	66.03	68.3	-3.65	37.39	7.49	46.26	100	168	Peak
5510	97.18	98.51			37.41	7.51	46.25	100	168	Average
5510	100.65	101.98			37.41	7.51	46.25	100	168	Peak

REMARKS:

- Emission Level = Read Level+ Antenna Factor + Cable Loss- Preamp Factor
Margin value = Emission level – Limit value.
- 5510MHz: Fundamental frequency.
- #: Out of restricted band.



CHANNEL	TX Channel 110	DETECTOR FUNCTION	Peak (PK)
FREQUENCY RANGE	1GHz ~ 40GHz		Average (AV)

ANTENNA POLARITY & TEST DISTANCE: HORIZONTAL AT 3 M										
FREQ. (MHz)	EMISSION LEVEL (dBuV/m)	READ LEVEL (dBuV)	LIMIT (dBuV/m)	MARGIN (dB)	ANTENNA FACTOR (dB /m)	CABLE LOSS (dB)	PREAMP FACTOR (dB)	ANTENNA HEIGHT (cm)	TABLE ANGLE (Degree)	REMARK
5460	47.92	49.31	54	-6.08	37.38	7.49	46.26	100	165	Average
5460	56.25	57.64	74	-17.75	37.38	7.49	46.26	100	165	Peak
#5470	57.43	58.81	68.3	-10.87	37.39	7.49	46.26	100	165	Peak
5550	91.9	93.16			37.43	7.55	46.24	100	165	Average
5550	100.72	101.98			37.43	7.55	46.24	100	165	Peak

ANTENNA POLARITY & TEST DISTANCE: VERTICAL AT 3 M										
FREQ. (MHz)	EMISSION LEVEL (dBuV/m)	READ LEVEL (dBuV)	LIMIT (dBuV/m)	MARGIN (dB)	ANTENNA FACTOR (dB /m)	CABLE LOSS (dB)	PREAMP FACTOR (dB)	ANTENNA HEIGHT (cm)	TABLE ANGLE (Degree)	REMARK
5460	47.82	49.21	54	-6.18	37.38	7.49	46.26	100	167	Average
5460	57.86	59.25	74	-16.14	37.38	7.49	46.26	100	167	Peak
#5470	66.92	68.3	68.3	-1.38	37.39	7.49	46.26	100	167	Peak
5550	90.88	92.14			37.43	7.55	46.24	100	167	Average
5550	100.6	101.86			37.43	7.55	46.24	100	167	Peak

REMARKS:

- Emission Level = Read Level+ Antenna Factor + Cable Loss- Preamp Factor
Margin value = Emission level – Limit value.
- 5550MHz: Fundamental frequency.
- #: Out of restricted band.



CHANNEL	TX Channel 134	DETECTOR FUNCTION	Peak (PK)
FREQUENCY RANGE	1GHz ~ 40GHz		Average (AV)

ANTENNA POLARITY & TEST DISTANCE: HORIZONTAL AT 3 M										
FREQ. (MHz)	EMISSION LEVEL (dBuV/m)	READ LEVEL (dBuV)	LIMIT (dBuV/m)	MARGIN (dB)	ANTENNA FACTOR (dB /m)	CABLE LOSS (dB)	PREAMP FACTOR (dB)	ANTENNA HEIGHT (cm)	TABLE ANGLE (Degree)	REMARK
5670	89.38	90.41			37.5	7.67	46.2	100	167	Average
5670	98.68	99.71			37.5	7.67	46.2	100	167	Peak
#5725	60.07	61	68.3	-8.23	37.53	7.73	46.19	100	167	Peak
ANTENNA POLARITY & TEST DISTANCE: VERTICAL AT 3 M										
FREQ. (MHz)	EMISSION LEVEL (dBuV/m)	READ LEVEL (dBuV)	LIMIT (dBuV/m)	MARGIN (dB)	ANTENNA FACTOR (dB /m)	CABLE LOSS (dB)	PREAMP FACTOR (dB)	ANTENNA HEIGHT (cm)	TABLE ANGLE (Degree)	REMARK
5670	90.03	91.06			37.5	7.67	46.2	100	168	Average
5670	98.46	99.49			37.5	7.67	46.2	100	168	Peak
#5725	59.7	60.63	68.3	-8.6	37.53	7.73	46.19	100	168	Peak

REMARKS:

1. Emission Level = Read Level+ Antenna Factor + Cable Loss- Preamp Factor
Margin value = Emission level – Limit value.
2. 5670MHz: Fundamental frequency.
3. #: Out of restricted band.



Band 4

802.11a

CHANNEL	TX Channel 149	DETECTOR FUNCTION	Peak (PK)
FREQUENCY RANGE	1GHz ~ 40GHz		Average (AV)

ANTENNA POLARITY & TEST DISTANCE: HORIZONTAL AT 3 M										
FREQ. (MHz)	EMISSION LEVEL (dBuV/m)	READ LEVEL (dBuV)	LIMIT (dBuV/m)	MARGIN (dB)	ANTENNA FACTOR (dB /m)	CABLE LOSS (dB)	PREAMP FACTOR (dB)	ANTENNA HEIGHT (cm)	TABLE ANGLE (Degree)	REMARK
5745	96.13	97.01			37.55	7.75	46.18	100	164	Average
5745	105.86	106.74			37.55	7.75	46.18	100	164	Peak
ANTENNA POLARITY & TEST DISTANCE: VERTICAL AT 3 M										
FREQ. (MHz)	EMISSION LEVEL (dBuV/m)	READ LEVEL (dBuV)	LIMIT (dBuV/m)	MARGIN (dB)	ANTENNA FACTOR (dB /m)	CABLE LOSS (dB)	PREAMP FACTOR (dB)	ANTENNA HEIGHT (cm)	TABLE ANGLE (Degree)	REMARK
5745	93.98	94.86			37.55	7.75	46.18	100	165	Average
5745	104.98	105.86			37.55	7.75	46.18	100	165	Peak

REMARKS:

- Emission Level = Read Level+ Antenna Factor + Cable Loss- Preamp Factor
Margin value = Emission level – Limit value.
- 5745MHz: Fundamental frequency.



Oobe Data

802.11a

ANTENNA POLARITY & TEST DISTANCE: HORIZONTAL AT 3 M										
FREQ. (MHz)	EMISSION LEVEL (dBuV/m)	READ LEVEL (dBuV)	LIMIT (dBuV/m)	MARGIN (dB)	ANTENNA FACTOR (dB /m)	CABLE LOSS (dB)	PREAMP FACTOR (dB)	ANTENNA HEIGHT (cm)	TABLE ANGLE (Degree)	REMARK
5638.35	60.03	61.12	68.3	-8.27	37.48	7.64	46.21	100	360	Peak
5944.25	59.8	60.31	68.3	-8.5	37.67	7.95	46.13	100	360	Peak
ANTENNA POLARITY & TEST DISTANCE: VERTICAL AT 3 M										
FREQ. (MHz)	EMISSION LEVEL (dBuV/m)	READ LEVEL (dBuV)	LIMIT (dBuV/m)	MARGIN (dB)	ANTENNA FACTOR (dB /m)	CABLE LOSS (dB)	PREAMP FACTOR (dB)	ANTENNA HEIGHT (cm)	TABLE ANGLE (Degree)	REMARK
5637.88	59.79	60.88	68.3	-8.51	37.48	7.64	46.21	100	360	Peak
5939.98	60.42	60.94	68.3	-7.88	37.66	7.95	46.13	100	360	Peak

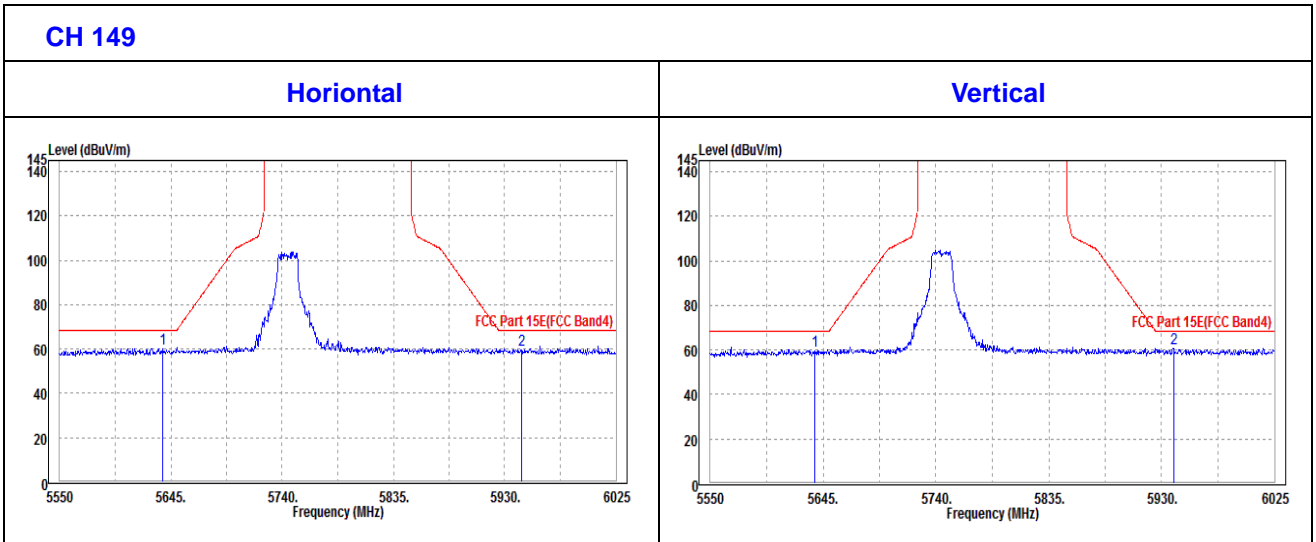



CHANNEL	TX Channel 157	DETECTOR FUNCTION	Peak (PK)
FREQUENCY RANGE	1GHz ~ 40GHz		Average (AV)

ANTENNA POLARITY & TEST DISTANCE: HORIZONTAL AT 3 M										
FREQ. (MHz)	EMISSION LEVEL (dBuV/m)	READ LEVEL (dBuV)	LIMIT (dBuV/m)	MARGIN (dB)	ANTENNA FACTOR (dB /m)	CABLE LOSS (dB)	PREAMP FACTOR (dB)	ANTENNA HEIGHT (cm)	TABLE ANGLE (Degree)	REMARK
5785	91.44	92.25			37.57	7.79	46.17	100	177	Average
5785	102.9	103.71			37.57	7.79	46.17	100	177	Peak

ANTENNA POLARITY & TEST DISTANCE: VERTICAL AT 3 M										
FREQ. (MHz)	EMISSION LEVEL (dBuV/m)	READ LEVEL (dBuV)	LIMIT (dBuV/m)	MARGIN (dB)	ANTENNA FACTOR (dB /m)	CABLE LOSS (dB)	PREAMP FACTOR (dB)	ANTENNA HEIGHT (cm)	TABLE ANGLE (Degree)	REMARK
5785	93.08	93.89			37.57	7.79	46.17	100	162	Average
5785	104.7	105.51			37.57	7.79	46.17	100	162	Peak

REMARKS:

- Emission Level = Read Level+ Antenna Factor + Cable Loss- Preamp Factor
Margin value = Emission level – Limit value.
- 5785MHz: Fundamental frequency.



Oobe Data

802.11a

ANTENNA POLARITY & TEST DISTANCE: HORIZONTAL AT 3 M										
FREQ. (MHz)	EMISSION LEVEL (dBuV/m)	READ LEVEL (dBuV)	LIMIT (dBuV/m)	MARGIN (dB)	ANTENNA FACTOR (dB /m)	CABLE LOSS (dB)	PREAMP FACTOR (dB)	ANTENNA HEIGHT (cm)	TABLE ANGLE (Degree)	REMARK
5639.78	49.99	51.08	68.3	-18.31	37.48	7.64	46.21	100	360	Peak
5942.35	51.14	51.65	68.3	-17.16	37.67	7.95	46.13	100	360	Peak
ANTENNA POLARITY & TEST DISTANCE: VERTICAL AT 3 M										
FREQ. (MHz)	EMISSION LEVEL (dBuV/m)	READ LEVEL (dBuV)	LIMIT (dBuV/m)	MARGIN (dB)	ANTENNA FACTOR (dB /m)	CABLE LOSS (dB)	PREAMP FACTOR (dB)	ANTENNA HEIGHT (cm)	TABLE ANGLE (Degree)	REMARK
5641.2	50.38	51.47	68.3	-17.92	37.48	7.64	46.21	100	360	Peak
5947.1	50.21	50.7	68.3	-18.09	37.67	7.96	46.12	100	360	Peak

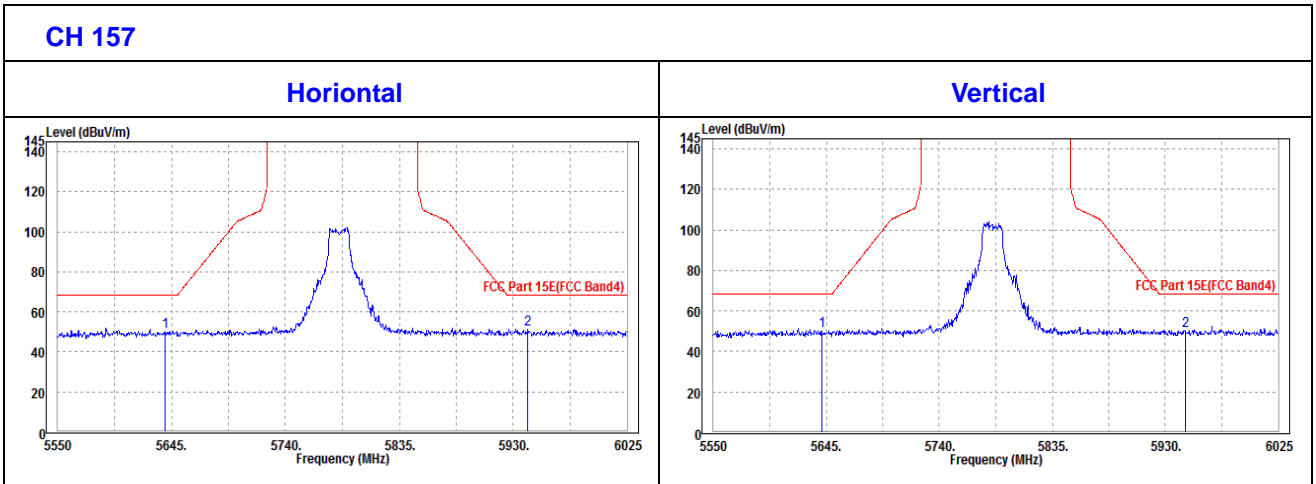



CHANNEL	TX Channel 165	DETECTOR FUNCTION	Peak (PK)
FREQUENCY RANGE	1GHz ~ 40GHz		Average (AV)

ANTENNA POLARITY & TEST DISTANCE: HORIZONTAL AT 3 M										
FREQ. (MHz)	EMISSION LEVEL (dBuV/m)	READ LEVEL (dBuV)	LIMIT (dBuV/m)	MARGIN (dB)	ANTENNA FACTOR (dB /m)	CABLE LOSS (dB)	PREAMP FACTOR (dB)	ANTENNA HEIGHT (cm)	TABLE ANGLE (Degree)	REMARK
5825	92.19	92.92			37.6	7.83	46.16	100	153	Average
5825	102.33	103.06			37.6	7.83	46.16	100	153	Peak
ANTENNA POLARITY & TEST DISTANCE: VERTICAL AT 3 M										
FREQ. (MHz)	EMISSION LEVEL (dBuV/m)	READ LEVEL (dBuV)	LIMIT (dBuV/m)	MARGIN (dB)	ANTENNA FACTOR (dB /m)	CABLE LOSS (dB)	PREAMP FACTOR (dB)	ANTENNA HEIGHT (cm)	TABLE ANGLE (Degree)	REMARK
5825	94.45	95.18			37.6	7.83	46.16	100	170	Average
5825	104.24	104.97			37.6	7.83	46.16	100	170	Peak

REMARKS:

- Emission Level = Read Level+ Antenna Factor + Cable Loss- Preamp Factor
Margin value = Emission level – Limit value.
- 5825MHz: Fundamental frequency.



Oobe Data

802.11a

ANTENNA POLARITY & TEST DISTANCE: HORIZONTAL AT 3 M										
FREQ. (MHz)	EMISSION LEVEL (dBuV/m)	READ LEVEL (dBuV)	LIMIT (dBuV/m)	MARGIN (dB)	ANTENNA FACTOR (dB /m)	CABLE LOSS (dB)	PREAMP FACTOR (dB)	ANTENNA HEIGHT (cm)	TABLE ANGLE (Degree)	REMARK
5632.18	50.5	51.6	68.3	-17.8	37.48	7.63	46.21	100	360	Peak
5956.6	49.93	50.41	68.3	-18.37	37.67	7.97	46.12	100	360	Peak
ANTENNA POLARITY & TEST DISTANCE: VERTICAL AT 3 M										
FREQ. (MHz)	EMISSION LEVEL (dBuV/m)	READ LEVEL (dBuV)	LIMIT (dBuV/m)	MARGIN (dB)	ANTENNA FACTOR (dB /m)	CABLE LOSS (dB)	PREAMP FACTOR (dB)	ANTENNA HEIGHT (cm)	TABLE ANGLE (Degree)	REMARK
5642.63	50.48	51.55	68.3	-17.82	37.49	7.65	46.21	100	360	Peak
5942.35	50.28	50.79	68.3	-18.02	37.67	7.95	46.13	100	360	Peak

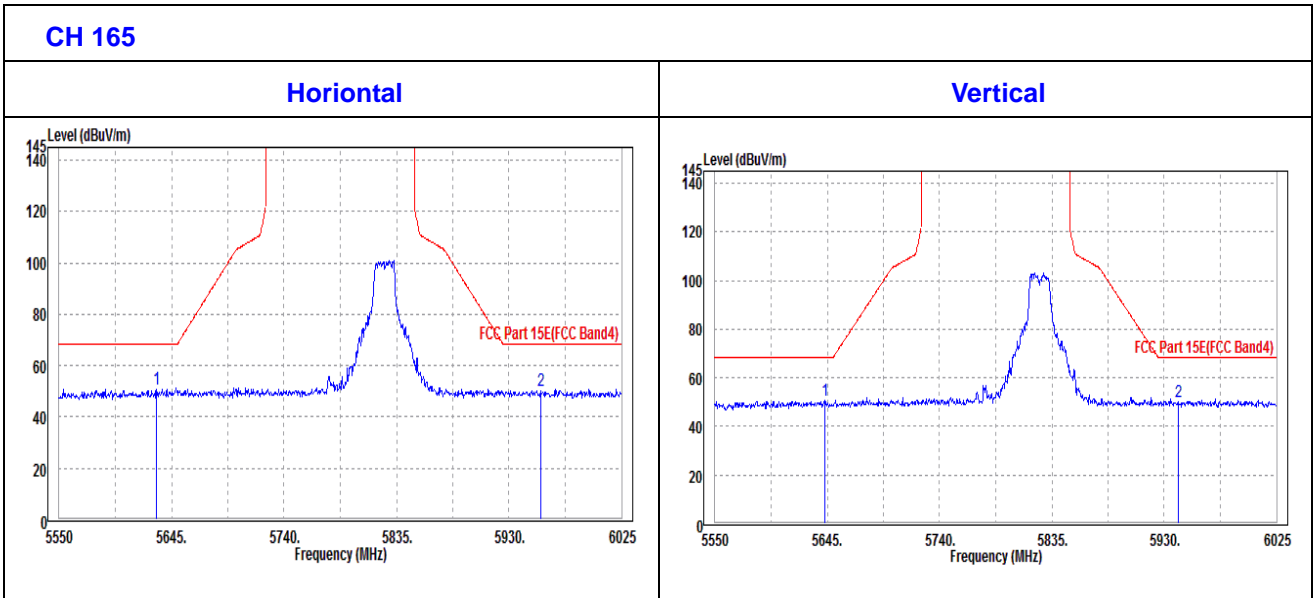



802.11n (20MHz)

CHANNEL	TX Channel 149	DETECTOR FUNCTION	Peak (PK)
FREQUENCY RANGE	1GHz ~ 40GHz		Average (AV)

ANTENNA POLARITY & TEST DISTANCE: HORIZONTAL AT 3 M										
FREQ. (MHz)	EMISSION LEVEL (dBuV/m)	READ LEVEL (dBuV)	LIMIT (dBuV/m)	MARGIN (dB)	ANTENNA FACTOR (dB /m)	CABLE LOSS (dB)	PREAMP FACTOR (dB)	ANTENNA HEIGHT (cm)	TABLE ANGLE (Degree)	REMARK
5745	91.45	92.33			37.55	7.75	46.18	100	191	Average
5745	101.84	102.72			37.55	7.75	46.18	100	191	Peak
ANTENNA POLARITY & TEST DISTANCE: VERTICAL AT 3 M										
FREQ. (MHz)	EMISSION LEVEL (dBuV/m)	READ LEVEL (dBuV)	LIMIT (dBuV/m)	MARGIN (dB)	ANTENNA FACTOR (dB /m)	CABLE LOSS (dB)	PREAMP FACTOR (dB)	ANTENNA HEIGHT (cm)	TABLE ANGLE (Degree)	REMARK
5745	94.03	94.91			37.55	7.75	46.18	100	165	Average
5745	104.16	105.04			37.55	7.75	46.18	100	165	Peak

REMARKS:

1. Emission Level = Read Level+ Antenna Factor + Cable Loss- Preamp Factor
Margin value = Emission level – Limit value.
2. 5745MHz: Fundamental frequency.



Oobe Data

802.11n (20MHz)

ANTENNA POLARITY & TEST DISTANCE: HORIZONTAL AT 3 M										
FREQ. (MHz)	EMISSION LEVEL (dBuV/m)	READ LEVEL (dBuV)	LIMIT (dBuV/m)	MARGIN (dB)	ANTENNA FACTOR (dB /m)	CABLE LOSS (dB)	PREAMP FACTOR (dB)	ANTENNA HEIGHT (cm)	TABLE ANGLE (Degree)	REMARK
5640.73	51.88	52.97	68.3	-16.42	37.48	7.64	46.21	100	0	Peak
5931.9	50.66	51.19	68.3	-17.64	37.66	7.94	46.13	100	0	Peak
ANTENNA POLARITY & TEST DISTANCE: VERTICAL AT 3 M										
FREQ. (MHz)	EMISSION LEVEL (dBuV/m)	READ LEVEL (dBuV)	LIMIT (dBuV/m)	MARGIN (dB)	ANTENNA FACTOR (dB /m)	CABLE LOSS (dB)	PREAMP FACTOR (dB)	ANTENNA HEIGHT (cm)	TABLE ANGLE (Degree)	REMARK
5634.55	51.06	52.15	68.3	-17.24	37.48	7.64	46.21	100	360	Peak
5946.63	50.37	50.86	68.3	-17.93	37.67	7.96	46.12	100	360	Peak

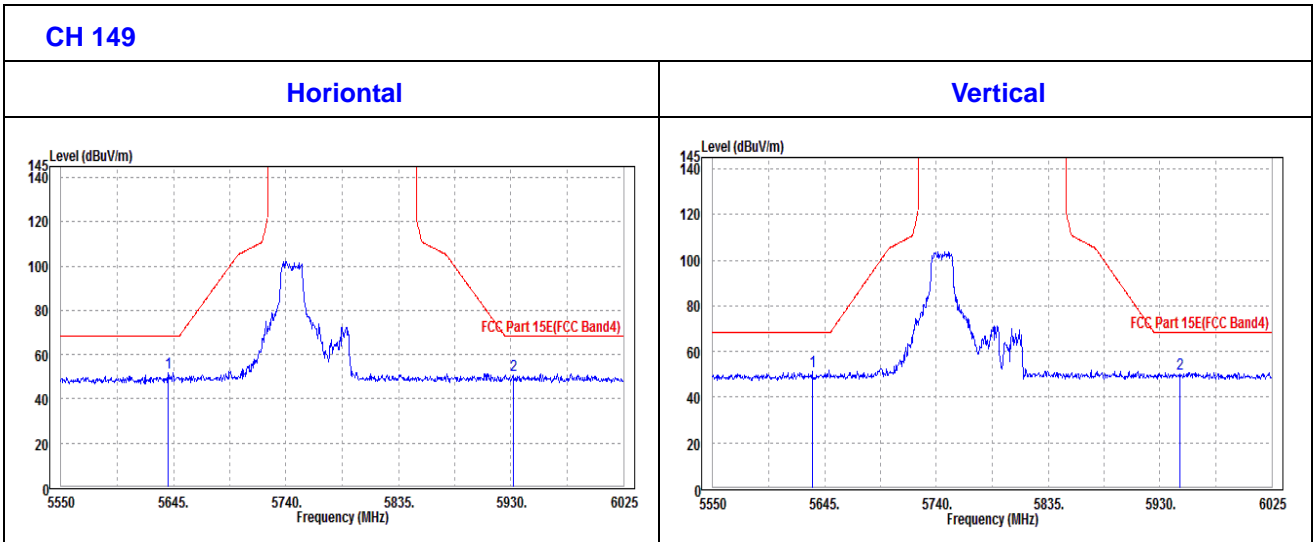



CHANNEL	TX Channel 157	DETECTOR FUNCTION	Peak (PK)
FREQUENCY RANGE	1GHz ~ 40GHz		Average (AV)

ANTENNA POLARITY & TEST DISTANCE: HORIZONTAL AT 3 M										
FREQ. (MHz)	EMISSION LEVEL (dBuV/m)	READ LEVEL (dBuV)	LIMIT (dBuV/m)	MARGIN (dB)	ANTENNA FACTOR (dB /m)	CABLE LOSS (dB)	PREAMP FACTOR (dB)	ANTENNA HEIGHT (cm)	TABLE ANGLE (Degree)	REMARK
5785	92.46	93.27			37.57	7.79	46.17	100	185	Average
5785	102.25	103.06			37.57	7.79	46.17	100	185	Peak
ANTENNA POLARITY & TEST DISTANCE: VERTICAL AT 3 M										
FREQ. (MHz)	EMISSION LEVEL (dBuV/m)	READ LEVEL (dBuV)	LIMIT (dBuV/m)	MARGIN (dB)	ANTENNA FACTOR (dB /m)	CABLE LOSS (dB)	PREAMP FACTOR (dB)	ANTENNA HEIGHT (cm)	TABLE ANGLE (Degree)	REMARK
5785	94.65	95.46			37.57	7.79	46.17	100	165	Average
5785	107.64	108.45			37.57	7.79	46.17	100	165	Peak

REMARKS:

1. Emission Level = Read Level+ Antenna Factor + Cable Loss- Preamp Factor
Margin value = Emission level – Limit value.
2. 5785MHz: Fundamental frequency.



Oobe Data

802.11n (20MHz)

ANTENNA POLARITY & TEST DISTANCE: HORIZONTAL AT 3 M										
FREQ. (MHz)	EMISSION LEVEL (dBuV/m)	READ LEVEL (dBuV)	LIMIT (dBuV/m)	MARGIN (dB)	ANTENNA FACTOR (dB /m)	CABLE LOSS (dB)	PREAMP FACTOR (dB)	ANTENNA HEIGHT (cm)	TABLE ANGLE (Degree)	REMARK
5638.35	50.32	51.41	68.3	-17.98	37.48	7.64	46.21	100	360	Peak
5937.6	50.25	50.77	68.3	-18.05	37.66	7.95	46.13	100	360	Peak
ANTENNA POLARITY & TEST DISTANCE: VERTICAL AT 3 M										
FREQ. (MHz)	EMISSION LEVEL (dBuV/m)	READ LEVEL (dBuV)	LIMIT (dBuV/m)	MARGIN (dB)	ANTENNA FACTOR (dB /m)	CABLE LOSS (dB)	PREAMP FACTOR (dB)	ANTENNA HEIGHT (cm)	TABLE ANGLE (Degree)	REMARK
5624.1	52.26	53.38	68.3	-16.04	37.47	7.63	46.22	100	0	Peak
5944.73	50.22	50.73	68.3	-18.08	37.67	7.95	46.13	100	0	Peak

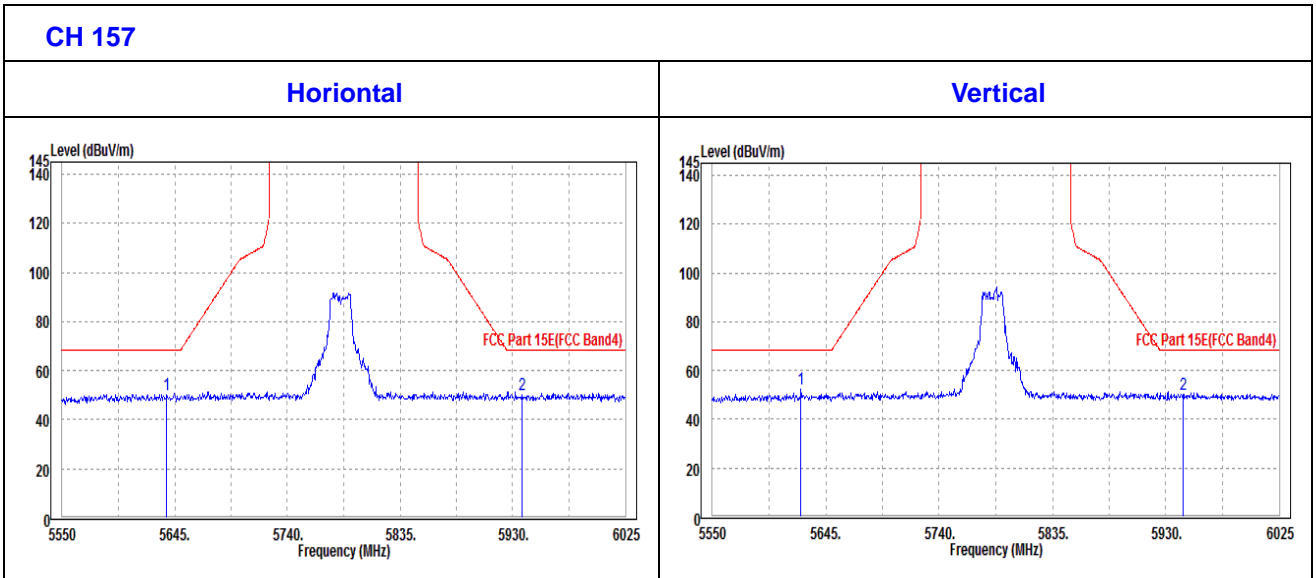



CHANNEL	TX Channel 165	DETECTOR FUNCTION	Peak (PK)
FREQUENCY RANGE	1GHz ~ 40GHz		Average (AV)

ANTENNA POLARITY & TEST DISTANCE: HORIZONTAL AT 3 M										
FREQ. (MHz)	EMISSION LEVEL (dBuV/m)	READ LEVEL (dBuV)	LIMIT (dBuV/m)	MARGIN (dB)	ANTENNA FACTOR (dB /m)	CABLE LOSS (dB)	PREAMP FACTOR (dB)	ANTENNA HEIGHT (cm)	TABLE ANGLE (Degree)	REMARK
5825	92.19	92.92			37.6	7.83	46.16	100	191	Average
5825	102.24	102.97			37.6	7.83	46.16	100	191	Peak
ANTENNA POLARITY & TEST DISTANCE: VERTICAL AT 3 M										
FREQ. (MHz)	EMISSION LEVEL (dBuV/m)	READ LEVEL (dBuV)	LIMIT (dBuV/m)	MARGIN (dB)	ANTENNA FACTOR (dB /m)	CABLE LOSS (dB)	PREAMP FACTOR (dB)	ANTENNA HEIGHT (cm)	TABLE ANGLE (Degree)	REMARK
5825	94.51	95.24			37.6	7.83	46.16	100	163	Average
5825	105.08	105.81			37.6	7.83	46.16	100	163	Peak

REMARKS:

- Emission Level = Read Level+ Antenna Factor + Cable Loss- Preamp Factor
Margin value = Emission level – Limit value.
- 5825MHz: Fundamental frequency.



Oobe Data

802.11n (20MHz)

ANTENNA POLARITY & TEST DISTANCE: HORIZONTAL AT 3 M										
FREQ. (MHz)	EMISSION LEVEL (dBuV/m)	READ LEVEL (dBuV)	LIMIT (dBuV/m)	MARGIN (dB)	ANTENNA FACTOR (dB /m)	CABLE LOSS (dB)	PREAMP FACTOR (dB)	ANTENNA HEIGHT (cm)	TABLE ANGLE (Degree)	REMARK
5632.18	50.84	51.94	68.3	-17.46	37.48	7.63	46.21	100	0	Peak
5940.45	50.24	50.76	68.3	-18.06	37.66	7.95	46.13	100	0	Peak
ANTENNA POLARITY & TEST DISTANCE: VERTICAL AT 3 M										
FREQ. (MHz)	EMISSION LEVEL (dBuV/m)	READ LEVEL (dBuV)	LIMIT (dBuV/m)	MARGIN (dB)	ANTENNA FACTOR (dB /m)	CABLE LOSS (dB)	PREAMP FACTOR (dB)	ANTENNA HEIGHT (cm)	TABLE ANGLE (Degree)	REMARK
5634.55	50.57	51.66	68.3	-17.73	37.48	7.64	46.21	100	360	Peak
5938.08	50.84	51.36	68.3	-17.46	37.66	7.95	46.13	100	360	Peak

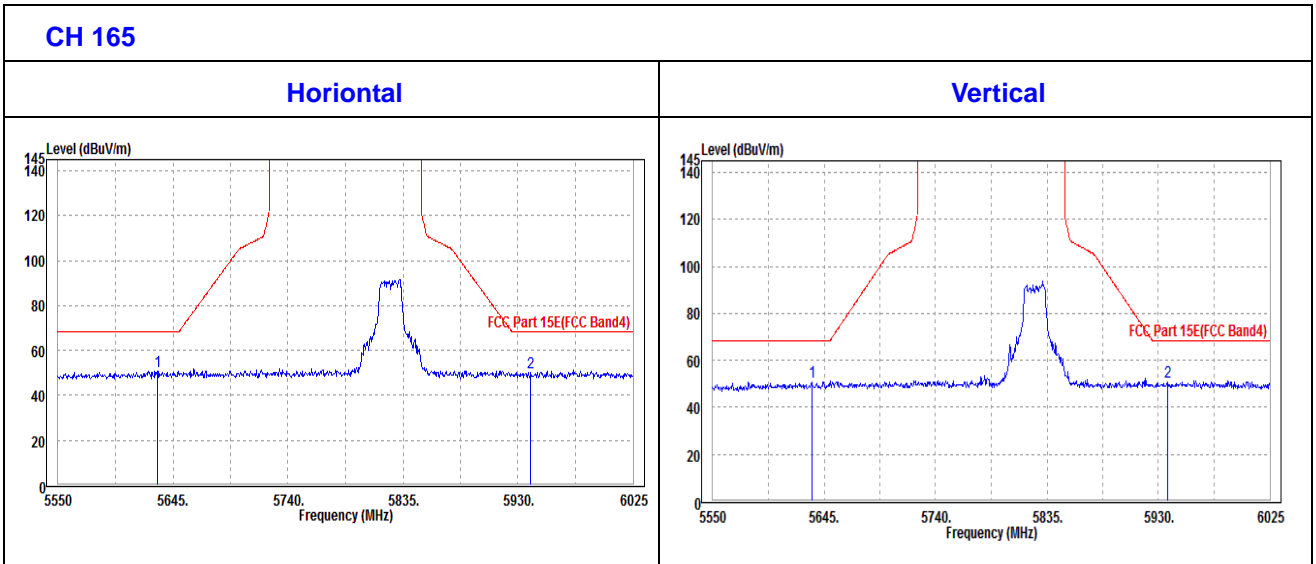



802.11n (40MHz)

CHANNEL	TX Channel 151	DETECTOR FUNCTION	Peak (PK)
FREQUENCY RANGE	1GHz ~ 40GHz		Average (AV)

ANTENNA POLARITY & TEST DISTANCE: HORIZONTAL AT 3 M										
FREQ. (MHz)	EMISSION LEVEL (dBuV/m)	READ LEVEL (dBuV)	LIMIT (dBuV/m)	MARGIN (dB)	ANTENNA FACTOR (dB /m)	CABLE LOSS (dB)	PREAMP FACTOR (dB)	ANTENNA HEIGHT (cm)	TABLE ANGLE (Degree)	REMARK
5755	83.34	84.21			37.55	7.76	46.18	100	154	5755
5755	92.45	93.32			37.55	7.76	46.18	100	154	5755
ANTENNA POLARITY & TEST DISTANCE: VERTICAL AT 3 M										
FREQ. (MHz)	EMISSION LEVEL (dBuV/m)	READ LEVEL (dBuV)	LIMIT (dBuV/m)	MARGIN (dB)	ANTENNA FACTOR (dB /m)	CABLE LOSS (dB)	PREAMP FACTOR (dB)	ANTENNA HEIGHT (cm)	TABLE ANGLE (Degree)	REMARK
5755	86.14	87.01			37.55	7.76	46.18	100	172	Average
5755	94.86	95.73			37.55	7.76	46.18	100	172	Peak

REMARKS:

1. Emission Level = Read Level+ Antenna Factor + Cable Loss- Preamp Factor
Margin value = Emission level – Limit value.
2. 5755MHz: Fundamental frequency.



Oobe Data

802.11n (40MHz)

ANTENNA POLARITY & TEST DISTANCE: HORIZONTAL AT 3 M										
FREQ. (MHz)	EMISSION LEVEL (dBuV/m)	READ LEVEL (dBuV)	LIMIT (dBuV/m)	MARGIN (dB)	ANTENNA FACTOR (dB /m)	CABLE LOSS (dB)	PREAMP FACTOR (dB)	ANTENNA HEIGHT (cm)	TABLE ANGLE (Degree)	REMARK
5626	49.6	50.7	68.3	-18.7	37.48	7.63	46.21	100	0	Peak
5958.98	50.89	51.36	68.3	-17.41	37.68	7.97	46.12	100	0	Peak
ANTENNA POLARITY & TEST DISTANCE: VERTICAL AT 3 M										
FREQ. (MHz)	EMISSION LEVEL (dBuV/m)	READ LEVEL (dBuV)	LIMIT (dBuV/m)	MARGIN (dB)	ANTENNA FACTOR (dB /m)	CABLE LOSS (dB)	PREAMP FACTOR (dB)	ANTENNA HEIGHT (cm)	TABLE ANGLE (Degree)	REMARK
5630.75	49.68	50.78	68.3	-18.62	37.48	7.63	46.21	100	0	Peak
5953.75	51.29	51.78	68.3	-17.01	37.67	7.96	46.12	100	0	Peak

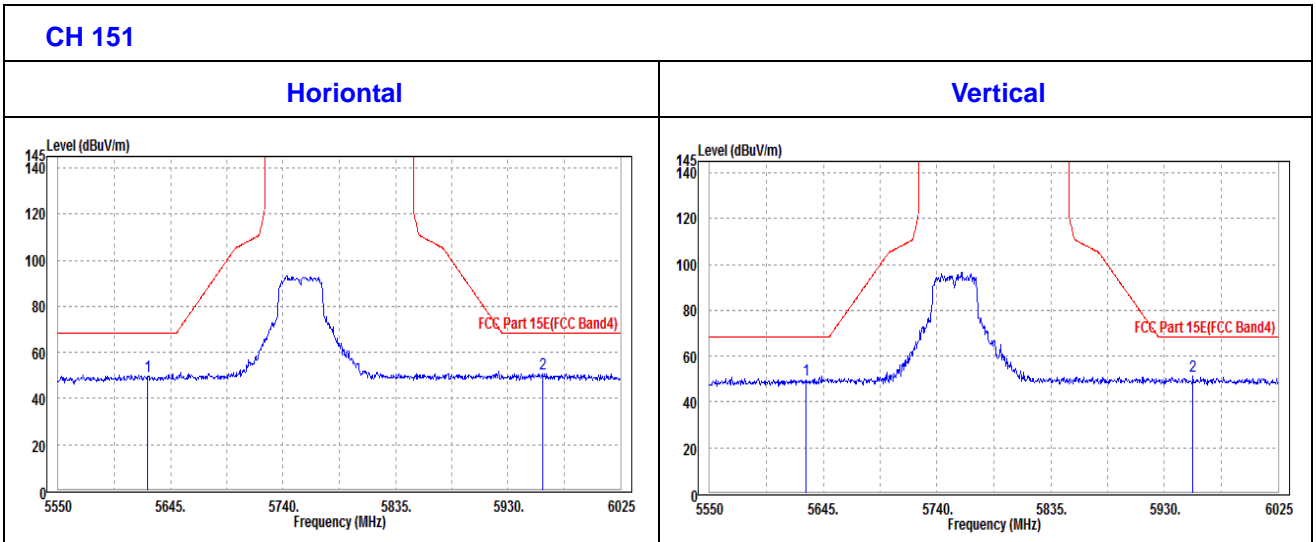



CHANNEL	TX Channel 159	DETECTOR FUNCTION	Peak (PK)
FREQUENCY RANGE	1GHz ~ 40GHz		Average (AV)

ANTENNA POLARITY & TEST DISTANCE: HORIZONTAL AT 3 M										
FREQ. (MHz)	EMISSION LEVEL (dBuV/m)	READ LEVEL (dBuV)	LIMIT (dBuV/m)	MARGIN (dB)	ANTENNA FACTOR (dB /m)	CABLE LOSS (dB)	PREAMP FACTOR (dB)	ANTENNA HEIGHT (cm)	TABLE ANGLE (Degree)	REMARK
5795	81.9	82.69			37.58	7.8	46.17	100	191	Average
5795	91.29	92.08			37.58	7.8	46.17	100	191	Peak
ANTENNA POLARITY & TEST DISTANCE: VERTICAL AT 3 M										
FREQ. (MHz)	EMISSION LEVEL (dBuV/m)	READ LEVEL (dBuV)	LIMIT (dBuV/m)	MARGIN (dB)	ANTENNA FACTOR (dB /m)	CABLE LOSS (dB)	PREAMP FACTOR (dB)	ANTENNA HEIGHT (cm)	TABLE ANGLE (Degree)	REMARK
5795	84.98	85.77			37.58	7.8	46.17	100	171	Average
5795	94.07	94.86			37.58	7.8	46.17	100	171	Peak

REMARKS:

1. Emission Level = Read Level+ Antenna Factor + Cable Loss- Preamp Factor
Margin value = Emission level – Limit value.
2. 5795MHz: Fundamental frequency.



Oobe Data

802.11n (40MHz)

ANTENNA POLARITY & TEST DISTANCE: HORIZONTAL AT 3 M										
FREQ. (MHz)	EMISSION LEVEL (dBuV/m)	READ LEVEL (dBuV)	LIMIT (dBuV/m)	MARGIN (dB)	ANTENNA FACTOR (dB /m)	CABLE LOSS (dB)	PREAMP FACTOR (dB)	ANTENNA HEIGHT (cm)	TABLE ANGLE (Degree)	REMARK
5619.83	50.12	51.25	68.3	-18.18	37.47	7.62	46.22	100	0	Peak
5953.28	49.62	50.11	68.3	-18.68	37.67	7.96	46.12	100	0	Peak
ANTENNA POLARITY & TEST DISTANCE: VERTICAL AT 3 M										
FREQ. (MHz)	EMISSION LEVEL (dBuV/m)	READ LEVEL (dBuV)	LIMIT (dBuV/m)	MARGIN (dB)	ANTENNA FACTOR (dB /m)	CABLE LOSS (dB)	PREAMP FACTOR (dB)	ANTENNA HEIGHT (cm)	TABLE ANGLE (Degree)	REMARK
5638.35	51.63	52.72	68.3	-16.67	37.48	7.64	46.21	100	191	Peak
5948.53	50.52	51.01	68.3	-17.78	37.67	7.96	46.12	100	191	Peak

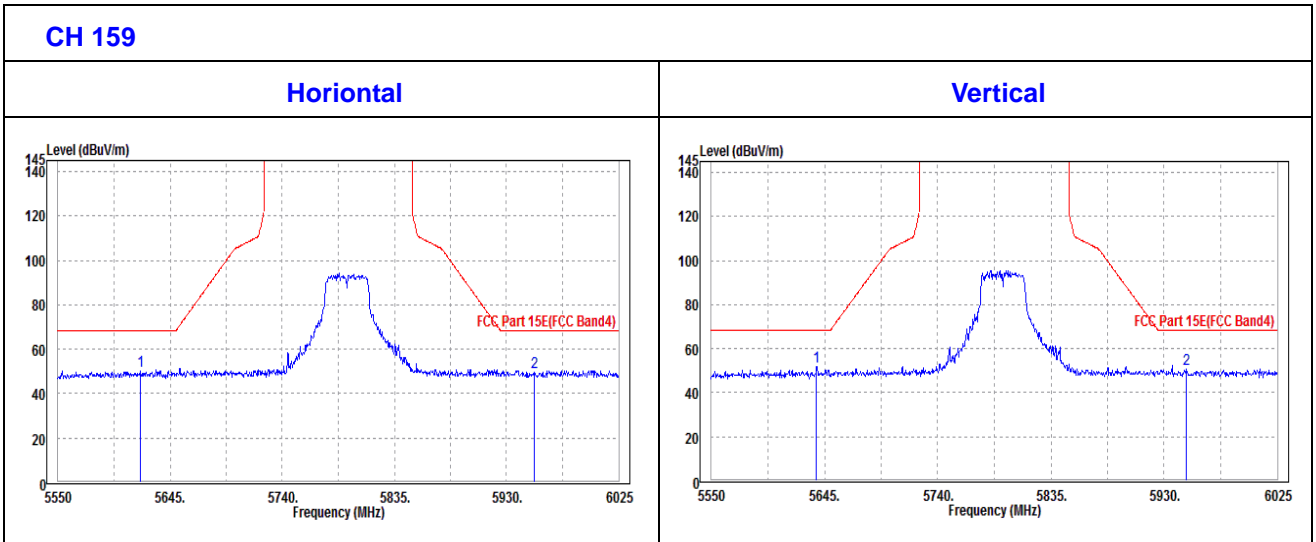



3.2 CONDUCTED EMISSION MEASUREMENT

3.2.1 LIMITS OF CONDUCTED EMISSION MEASUREMENT

FREQUENCY OF EMISSION (MHz)	CONDUCTED LIMIT (dBµV)	
	Quasi-peak	Average
0.15 ~ 0.5	66 to 56	56 to 46
0.5 ~ 5	56	46
5 ~ 30	60	50

- NOTE:**
1. The lower limit shall apply at the transition frequencies.
 2. The limit decreases in line with the logarithm of the frequency in the range of 0.15 to 0.50MHz.
 3. All emanations from a class A/B digital device or system, including any network of conductors and apparatus connected thereto, shall not exceed the level of field strengths specified above.

3.2.2 TEST INSTRUMENTS

Equipment	Manufacturer	Model No.	Serial No.	Last Cal.	Next Cal.
EMI Test Receiver	Rohde&Schwarz	ESR3	101900	Mar. 15,18	Mar. 14,19
EMC32 test software	Rohde&Schwarz	EMC32	NA	NA	NA
LISN network	Rohde&Schwarz	ENV216	101922	Mar. 15,18	Mar. 14,19

- NOTE:**
1. The test was performed in CE shielded room.
 2. The calibration interval of the above test instruments is 12 months. And the calibrations are traceable to CEPREI/CHINA, GRGT/CHINA and NIM/CHINA.

3.2.3 TEST PROCEDURES

- a. The EUT was placed 0.4 meters from the conducting wall of the shielded room with EUT being connected to the power mains through a line impedance stabilization network (LISN). Other support units were connected to the power mains through another LISN. The two LISNs provide 50 ohm/ 50uH of coupling impedance for the measuring instrument.
- b. Both lines of the power mains connected to the EUT were checked for maximum conducted interference.
- c. The frequency range from 150kHz to 30MHz was searched. Emission levels under (Limit - 20dB) was not recorded.

NOTE: All modes of operation were investigated and the worst-case emissions are reported.



3.2.4 DEVIATION FROM TEST STANDARD

No deviation.

3.2.5 TEST SETUP

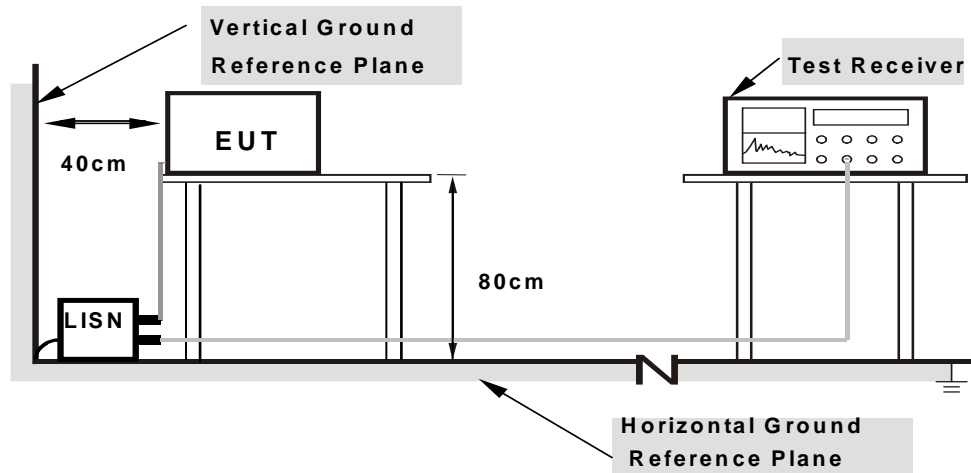

- Note:**
- 1.Support units were connected to second LISN.
 - 2.Both of LISNs (AMN) are 80 cm from EUT and at least 80 cm from other units and other metal planes

For the actual test configuration, please refer to the attached file (Test Setup Photo).

3.2.6 EUT OPERATING CONDITIONS

Same as 3.1.6.



3.2.7 TEST RESULTS

CONDUCTED WORST-CASE DATA :

Mode 1

Frequency Range	150KHz ~ 30MHz	Detector Function & Resolution Bandwidth	Quasi-Peak (QP) / Average (AV), 9 kHz
Input Power	120Vac, 60Hz	Environmental Conditions	24deg. C, 55RH
Tested By	John Wen	TEST DATE	2018/10/12

Frequency (MHz)	QuasiPeak (dBuV)	CAverage (dBuV)	Limit (dBuV)	Margin (dB)	Line	Filter	Corr. (dB)
0.348000	---	31.44	49.01	-17.57	L	ON	9.7
0.348000	44.12	---	59.01	-14.89	L	ON	9.7
0.544000	---	35.37	46.00	-10.63	L	ON	9.7
0.544000	46.83	---	56.00	-9.17	L	ON	9.7
1.036000	---	32.93	46.00	-13.07	L	ON	9.7
1.036000	44.41	---	56.00	-11.59	L	ON	9.7
2.012000	---	33.47	46.00	-12.53	L	ON	9.7
2.012000	44.07	---	56.00	-11.93	L	ON	9.7
3.400000	---	35.59	46.00	-10.41	L	ON	9.7
3.400000	44.66	---	56.00	-11.34	L	ON	9.7
3.928000	---	36.34	46.00	-9.66	L	ON	9.7
3.928000	45.29	---	56.00	-10.71	L	ON	9.7

- REMARKS:**
1. Q.P. and AV. are abbreviations of quasi-peak and average individually.
 2. "-": The Quasi-peak reading value also meets average limit and measurement with the average detector is unnecessary.
 3. The emission levels of other frequencies were very low against the limit.
 4. Margin value = Emission level - Limit value
 5. Correction factor = Insertion loss + Cable loss
 6. Emission Level = Correction Factor + Reading Value.

Full Spectrum

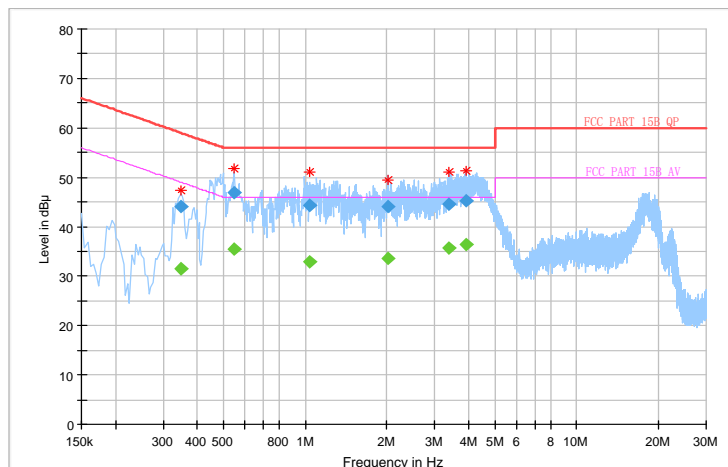



Frequency Range	150KHz ~ 30MHz	Detector Function & Resolution Bandwidth	Quasi-Peak (QP) / Average (AV), 9 kHz
Input Power	120Vac, 60Hz	Environmental Conditions	24deg. C, 55RH
Tested By	John Wen	TEST DATE	2018/10/12

Frequency (MHz)	QuasiPeak (dBuV)	CAverage (dBuV)	Limit (dBuV)	Margin (dB)	Line	Filter	Corr. (dB)
0.348000	---	33.71	49.01	-15.30	N	ON	10.0
0.348000	41.24	---	59.01	-17.77	N	ON	10.0
0.496000	---	35.94	46.07	-10.13	N	ON	10.1
0.496000	44.75	---	56.07	-11.32	N	ON	10.1
1.036000	---	28.09	46.00	-17.91	N	ON	9.9
1.036000	37.71	---	56.00	-18.29	N	ON	9.9
1.316000	---	27.35	46.00	-18.65	N	ON	9.9
1.316000	36.98	---	56.00	-19.02	N	ON	9.9
3.596000	---	28.20	46.00	-17.80	N	ON	9.8
3.596000	37.00	---	56.00	-19.00	N	ON	9.8
4.448000	---	32.33	46.00	-13.67	N	ON	9.8
4.448000	38.64	---	56.00	-17.36	N	ON	9.8

- REMARKS:**
1. Q.P. and AV. are abbreviations of quasi-peak and average individually.
 2. "-": The Quasi-peak reading value also meets average limit and measurement with the average detector is unnecessary.
 3. The emission levels of other frequencies were very low against the limit.
 4. Margin value = Emission level - Limit value
 5. Correction factor = Insertion loss + Cable loss
 6. Emission Level = Correction Factor + Reading Value.

Full Spectrum

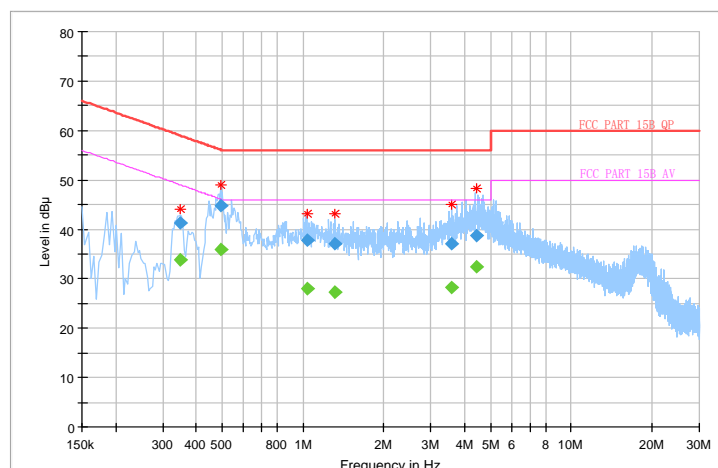



Mode 20

Frequency Range	150KHz ~ 30MHz	Detector Function & Resolution Bandwidth	Quasi-Peak (QP) / Average (AV), 9 kHz
Input Power	120Vac, 60Hz	Environmental Conditions	24deg. C, 55RH
Tested By	John Wen	TEST DATE	2018/10/12

Frequency (MHz)	QuasiPeak (dBuV)	CAverage (dBuV)	Limit (dBuV)	Margin (dB)	Line	Filter	Corr. (dB)
0.182000	---	31.19	54.39	-23.20	L	ON	9.7
0.182000	48.85	---	64.39	-15.54	L	ON	9.7
0.264000	---	28.44	51.30	-22.86	L	ON	9.7
0.264000	42.43	---	61.30	-18.87	L	ON	9.7
0.508000	---	22.57	46.00	-23.43	L	ON	9.7
0.508000	38.64	---	56.00	-17.36	L	ON	9.7
0.860000	---	23.44	46.00	-22.56	L	ON	9.7
0.860000	37.04	---	56.00	-18.96	L	ON	9.7
1.488000	---	23.96	46.00	-22.04	L	ON	9.7
1.488000	37.01	---	56.00	-18.99	L	ON	9.7
4.436000	---	32.44	46.00	-13.56	L	ON	9.7
4.436000	42.21	---	56.00	-13.79	L	ON	9.7

- REMARKS:**
1. Q.P. and AV. are abbreviations of quasi-peak and average individually.
 2. "-": The Quasi-peak reading value also meets average limit and measurement with the average detector is unnecessary.
 3. The emission levels of other frequencies were very low against the limit.
 4. Margin value = Emission level - Limit value
 5. Correction factor = Insertion loss + Cable loss
 6. Emission Level = Correction Factor + Reading Value.

Full Spectrum

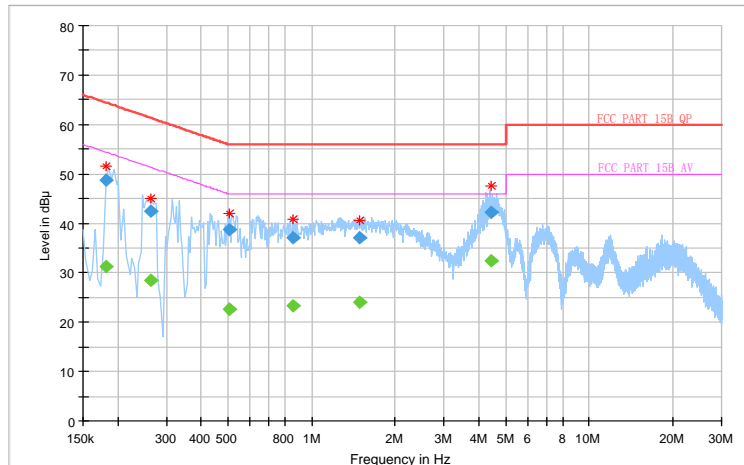



Frequency Range	150KHz ~ 30MHz	Detector Function & Resolution Bandwidth	Quasi-Peak (QP) / Average (AV), 9 kHz
Input Power	120Vac, 60Hz	Environmental Conditions	24deg. C, 55RH
Tested By	John Wen	TEST DATE	2018/10/12

Frequency (MHz)	QuasiPeak (dBuV)	CAverage (dBuV)	Limit (dBuV)	Margin (dB)	Line	Filter	Corr. (dB)
0.182000	---	33.82	54.39	-20.57	N	ON	10.2
0.182000	52.97	---	64.39	-11.42	N	ON	10.2
0.200000	---	34.67	53.61	-18.94	N	ON	9.9
0.200000	50.77	---	63.61	-12.84	N	ON	9.9
0.428000	---	18.37	47.29	-28.92	N	ON	10.1
0.428000	37.01	---	57.29	-20.28	N	ON	10.1
2.102000	---	20.12	46.00	-25.88	N	ON	9.8
2.102000	31.91	---	56.00	-24.09	N	ON	9.8
2.556000	---	20.72	46.00	-25.28	N	ON	9.8
2.556000	31.68	---	56.00	-24.32	N	ON	9.8
4.436000	---	33.29	46.00	-12.71	N	ON	9.8
4.436000	44.51	---	56.00	-11.49	N	ON	9.8

- REMARKS:**
1. Q.P. and AV. are abbreviations of quasi-peak and average individually.
 2. "-": The Quasi-peak reading value also meets average limit and measurement with the average detector is unnecessary.
 3. The emission levels of other frequencies were very low against the limit.
 4. Margin value = Emission level - Limit value
 5. Correction factor = Insertion loss + Cable loss
 6. Emission Level = Correction Factor + Reading Value.

Full Spectrum

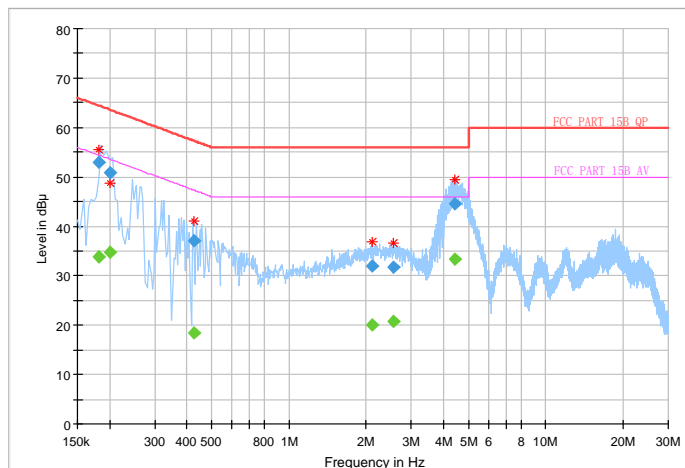



3.3 MAXIMUM CONDUCTED OUTPUT POWER MEASUREMENT

3.3.1 LIMITS OF MAXIMUM CONDUCTED OUTPUT POWER MEASUREMENT

Operation Band	EUT Category		LIMIT
U-NII-1		Outdoor Access Point	1 Watt (30 dBm) (Max. e.i.r.p \leq 125mW(21 dBm) at any elevation angle above 30 degrees as measured from the horizon)
		Fixed point-to-point Access Point	1 Watt (30 dBm)
		Indoor Access Point	1 Watt (30 dBm)
	√	Client devices	250mW (24 dBm)
U-NII-2A	√		250mW (24 dBm) or 11 dBm+10 log B*
U-NII-2C	√		250mW (24 dBm) or 11 dBm+10 log B*
U-NII-3	√		1 Watt (30 dBm)

NOTE: Where B is the 26dB emission bandwidth in MHz.



3.3.2 TEST SETUP

FOR POWER OUTPUT MEASUREMENT

802.11a, 802.11n (20MHz), 802.11n (40MHz) TEST CONFIGURATION

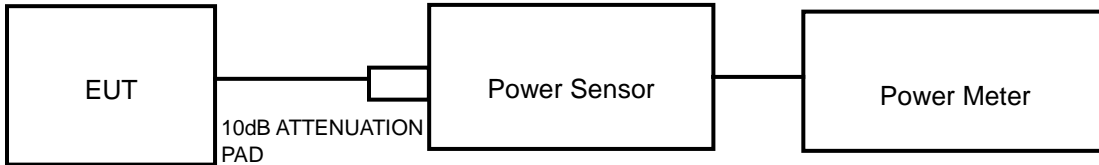

FOR 26dB BANDWIDTH

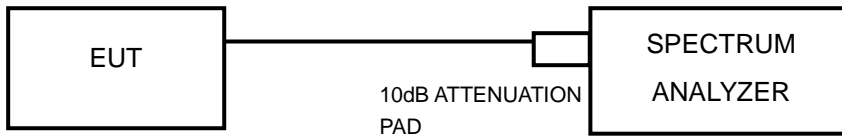

3.3.3 TEST INSTRUMENTS

Equipment	Manufacturer	Model No.	Serial No.	Last Cal.	Next Cal.
Power Meter	ANRITSU	ML2495A	1506002	Mar. 02,18	Mar. 01,19
EXA Signal Analyzer	KEYSIGHT	N9010A-526	MY54510523	Mar. 16,18	Mar. 15,19
EXA Signal Analyzer	KEYSIGHT	N9010A-544	MY54510332	Mar. 16,18	Mar. 15,19
Power Sensor	ANRITSU	MA2411B	1339352	Mar. 16,18	Mar. 15,19

NOTE:

1. The calibration interval of the above test instruments is 12 months and the calibrations are traceable to CEPREI/CHINA, GRGT/CHINA and NIM/CHINA.
2. The test was performed in RF Oven room.



3.3.4 TEST PROCEDURE

FOR POWER MEASUREMENT

For 802.11a, 802.11n (20MHz), 802.11n (40MHz)

Method PM is used to perform output power measurement, trigger and gating function of wide band power meter is enabled to measure max output power of TX on burst. Duty factor is not added to measured value.

FOR 99 PERCENT OCCUPIED BANDWIDTH

The following procedure shall be used for measuring (99 %) power bandwidth:

1. Set center frequency to the nominal EUT channel center frequency.
2. Set span = 1.5 times to 5.0 times the OBW.
3. Set RBW = 1 % to 5 % of the OBW
4. Set VBW $\geq 3 \cdot$ RBW
5. Video averaging is not permitted. Where practical, a sample detection and single sweep mode shall be used. Otherwise, peak detection and max hold mode (until the trace stabilizes) shall be used.
6. Use the 99 % power bandwidth function of the instrument (if available).
7. If the instrument does not have a 99 % power bandwidth function, the trace data points are recovered and directly summed in power units. The recovered amplitude data points, beginning at the lowest frequency, are placed in a running sum until 0.5 % of the total is reached; that frequency is recorded as the lower frequency. The process is repeated until 99.5 % of the total is reached; that frequency is recorded as the upper frequency. The 99% occupied bandwidth is the difference between these two frequencies.

FOR 26dB BANDWIDTH

- 1) Set RBW = approximately 1% of the emission bandwidth.
- 2) Set the VBW > RBW.
- 3) Detector = Peak.
- 4) Trace mode = max hold.
- 5) Measure the maximum width of the emission that is 26 dB down from the peak of the emission. Compare this with the RBW setting of the analyzer. Readjust RBW and repeat measurement as needed until the RBW/EBW ratio is approximately 1%.



FOR 6dB BANDWIDTH

1. Set RBW = 100 kHz.
2. Set the video bandwidth (VBW) ≥ 3 RBW.
3. Detector = Peak.
4. Trace mode = max hold.
5. Sweep = auto couple.
6. Allow the trace to stabilize.
7. Measure the maximum width of the emission that is constrained by the frequencies associated with the two outermost amplitude points (upper and lower frequencies) that are attenuated by 6 dB relative to the maximum level measured in the fundamental emission.

3.3.5 DEVIATION FROM TEST STANDARD

No deviation.

3.3.6 EUT OPERATING CONDITIONS

The software provided by client to enable the EUT under transmission condition continuously at specific channel frequencies individually.



3.3.7 TEST RESULTS

OUTPUT POWER:

802.11a

CHANNEL	CHANNEL FREQUENCY (MHz)	AVERAGE POWER (dBm)	AVERAGE POWER (mW)	POWER LIMIT (dBm)	PASS/FAIL
36	5180	16.00	39.81	24	PASS
40	5200	16.20	41.69	24	PASS
48	5240	15.50	35.48	24	PASS
52	5260	15.52	35.65	24	PASS
60	5300	15.56	35.97	24	PASS
64	5320	15.94	39.26	24	PASS
100	5500	15.25	33.50	24	PASS
116	5580	15.47	35.24	24	PASS
140	5700	15.50	35.48	24	PASS
149	5745	16.40	43.65	30	PASS
157	5785	16.62	45.92	30	PASS
165	5825	16.20	41.69	30	PASS

802.11n (20MHz)

CHANNEL	CHANNEL FREQUENCY (MHz)	AVERAGE POWER (dBm)	AVERAGE POWER (mW)	POWER LIMIT (dBm)	PASS/FAIL
36	5180	15.57	36.06	24	PASS
40	5200	15.84	38.37	24	PASS
48	5240	15.53	35.73	24	PASS
52	5260	15.40	34.67	24	PASS
60	5300	15.70	37.15	24	PASS
64	5320	15.97	39.54	24	PASS
100	5500	15.36	34.36	24	PASS
116	5580	15.70	37.15	24	PASS
140	5700	15.45	35.08	24	PASS
149	5745	16.45	44.16	30	PASS
157	5785	16.66	46.34	30	PASS
165	5825	16.22	41.88	30	PASS



802.11n (40MHz)

CHANNEL	CHANNEL FREQUENCY (MHz)	AVERAGE POWER (dBm)	AVERAGE POWER (mW)	POWER LIMIT (dBm)	PASS/FAIL
38	5190	12.25	16.79	24	PASS
46	5230	12.48	17.70	24	PASS
54	5270	12.08	16.14	24	PASS
62	5310	12.31	17.02	24	PASS
102	5510	12.05	16.03	24	PASS
110	5550	12.04	16.00	24	PASS
134	5670	12.16	16.44	24	PASS
151	5755	13.25	21.13	30	PASS
165	5825	13.59	22.86	30	PASS



99% OCCUPIED BANDWIDTH & 26dB BANDWIDTH/6dB BANDWIDTH:

802.11a

CHANNEL	CHANNEL FREQUENCY (MHz)	99% OCCUPIED BANDWIDTH	26dB BANDWIDTH (MHz)	PASS/FAIL
36	5180	18.60	41.86	PASS
40	5200	18.06	43.22	PASS
48	5240	18.60	38.89	PASS
52	5260	17.88	40.70	PASS
60	5300	17.82	42.12	PASS
64	5320	18.00	42.85	PASS
100	5500	18.96	39.50	PASS
116	5580	19.68	41.85	PASS
140	5700	20.10	40.49	PASS
CHANNEL	CHANNEL FREQUENCY (MHz)	99% OCCUPIED BANDWIDTH	6dB BANDWIDTH (MHz)	PASS/FAIL
149	5745	22.32	16.34	PASS
157	5785	24.30	16.34	PASS
165	5825	22.26	16.35	PASS



802.11n (20MHz)

CHANNEL	CHANNEL FREQUENCY (MHz)	99% OCCUPIED BANDWIDTH	26dB BANDWIDTH (MHz)	PASS/FAIL
36	5180	19.50	45.34	PASS
40	5200	18.78	44.06	PASS
48	5240	19.14	45.10	PASS
52	5260	18.96	43.35	PASS
60	5300	18.84	44.80	PASS
64	5320	18.81	46.13	PASS
100	5500	20.46	44.11	PASS
116	5580	19.94	44.69	PASS
140	5700	20.40	43.00	PASS
CHANNEL	CHANNEL FREQUENCY (MHz)	99% OCCUPIED BANDWIDTH	6dB BANDWIDTH (MHz)	PASS/FAIL
149	5745	23.22	17.56	PASS
157	5785	24.84	17.53	PASS
165	5825	22.74	17.58	PASS



802.11n (40MHz)

CHANNEL	CHANNEL FREQUENCY (MHz)	99% OCCUPIED BANDWIDTH	26dB BANDWIDTH (MHz)	PASS/FAIL
38	5190	38.76	83.83	PASS
46	5230	36.84	78.76	PASS
54	5270	37.26	78.06	PASS
62	5310	37.02	79.45	PASS
102	5510	37.44	62.63	PASS
110	5550	37.44	64.73	PASS
134	5670	37.74	69.54	PASS
CHANNEL	CHANNEL FREQUENCY (MHz)	99% OCCUPIED BANDWIDTH	6dB BANDWIDTH (MHz)	PASS/FAIL
151	5755	37.98	35.17	PASS
159	5795	37.74	35.19	PASS



BUREAU VERITAS

Test Report No.: RF180829W002-3

For U-NII-1:

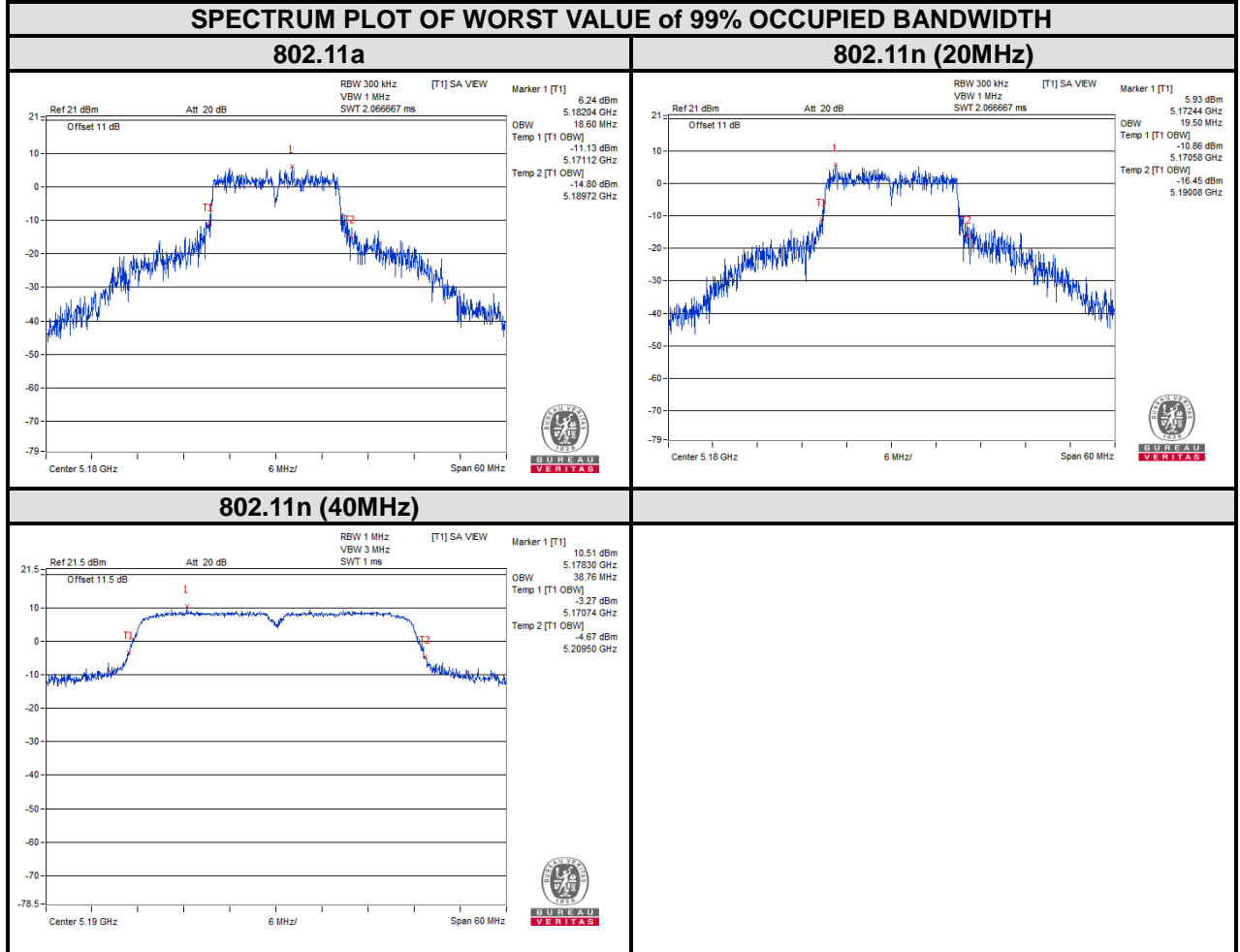



BUREAU VERITAS

Test Report No.: RF180829W002-3

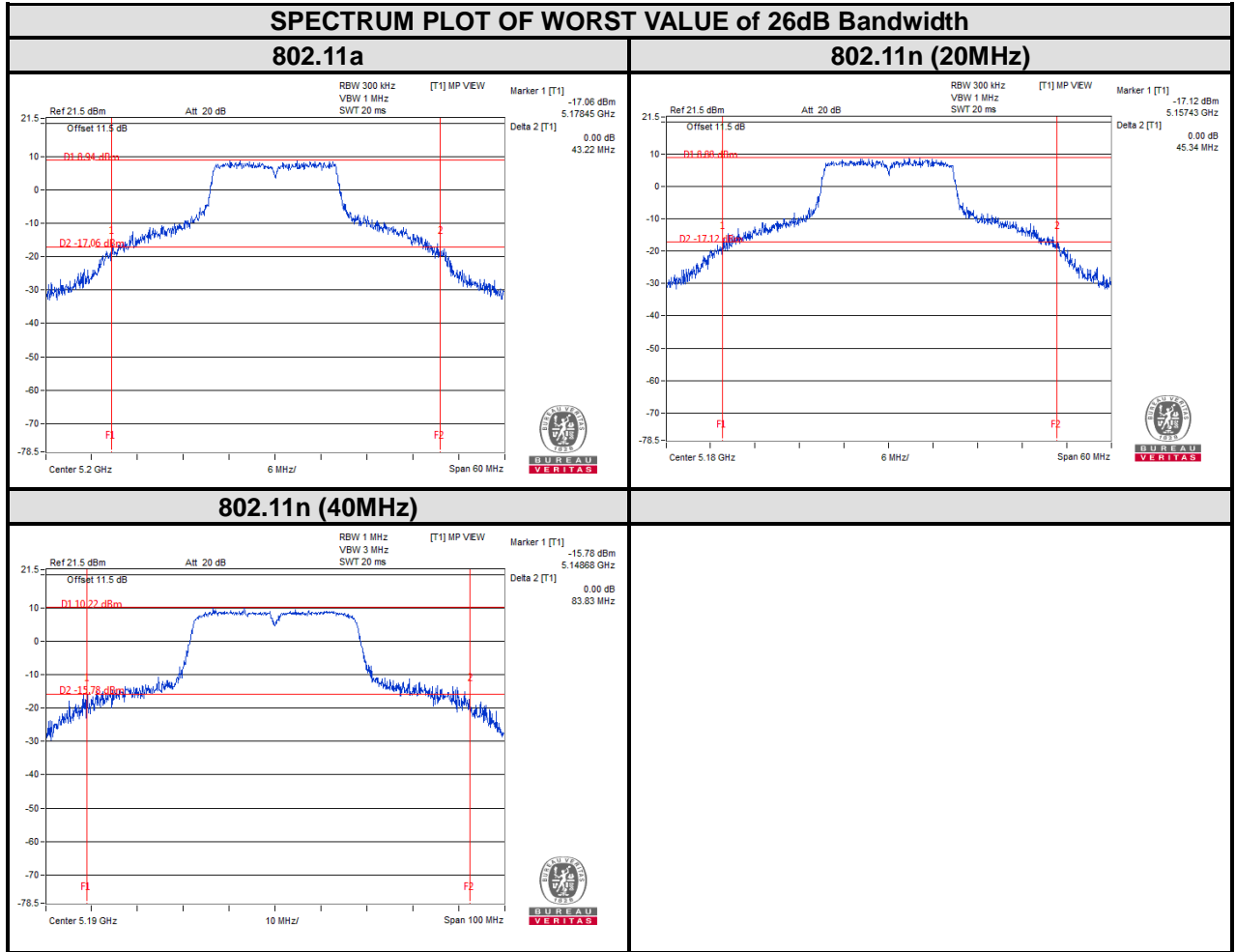



BUREAU VERITAS

Test Report No.: RF180829W002-3

For U-NII-2A:

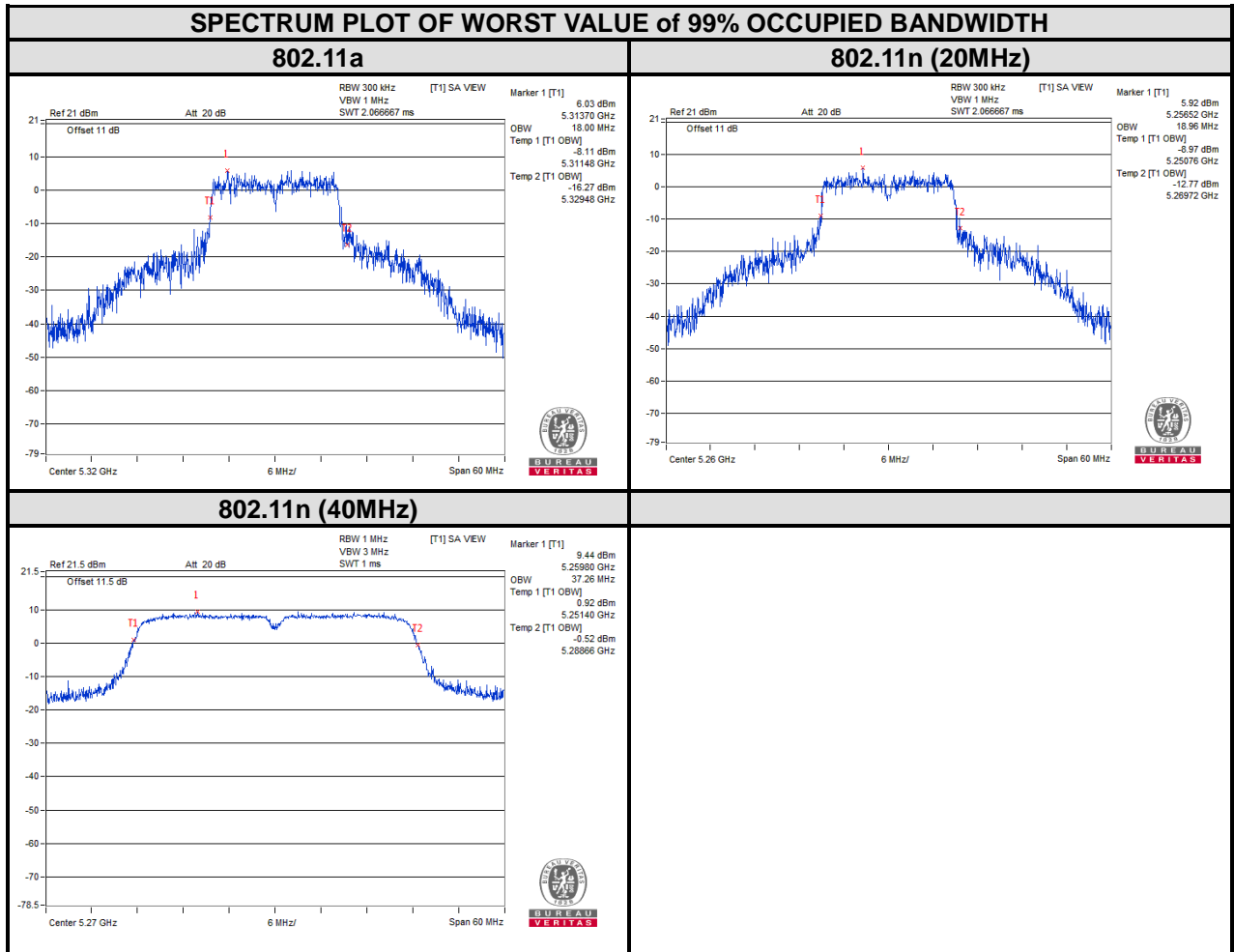

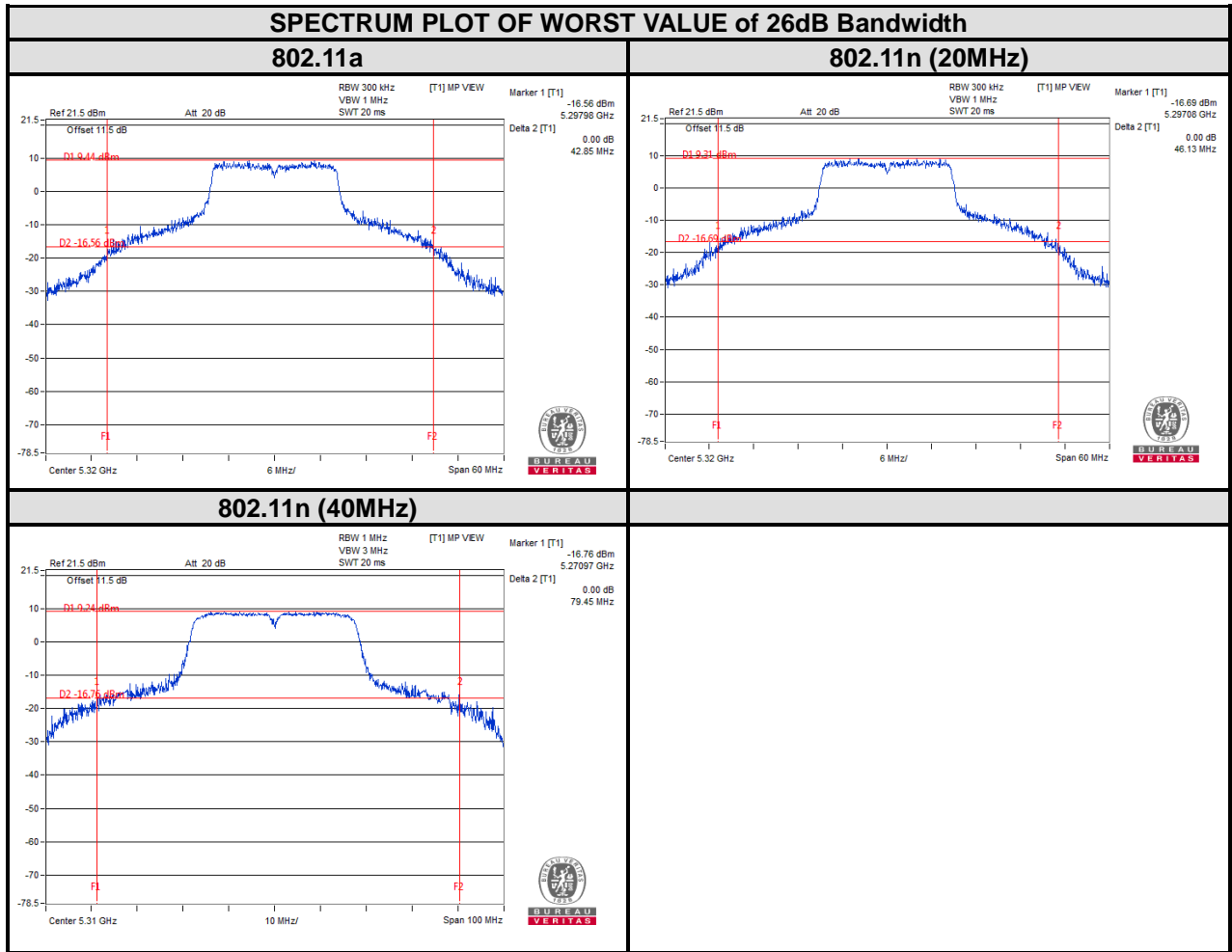



BUREAU VERITAS

Test Report No.: RF180829W002-3

For U-NII-2C:

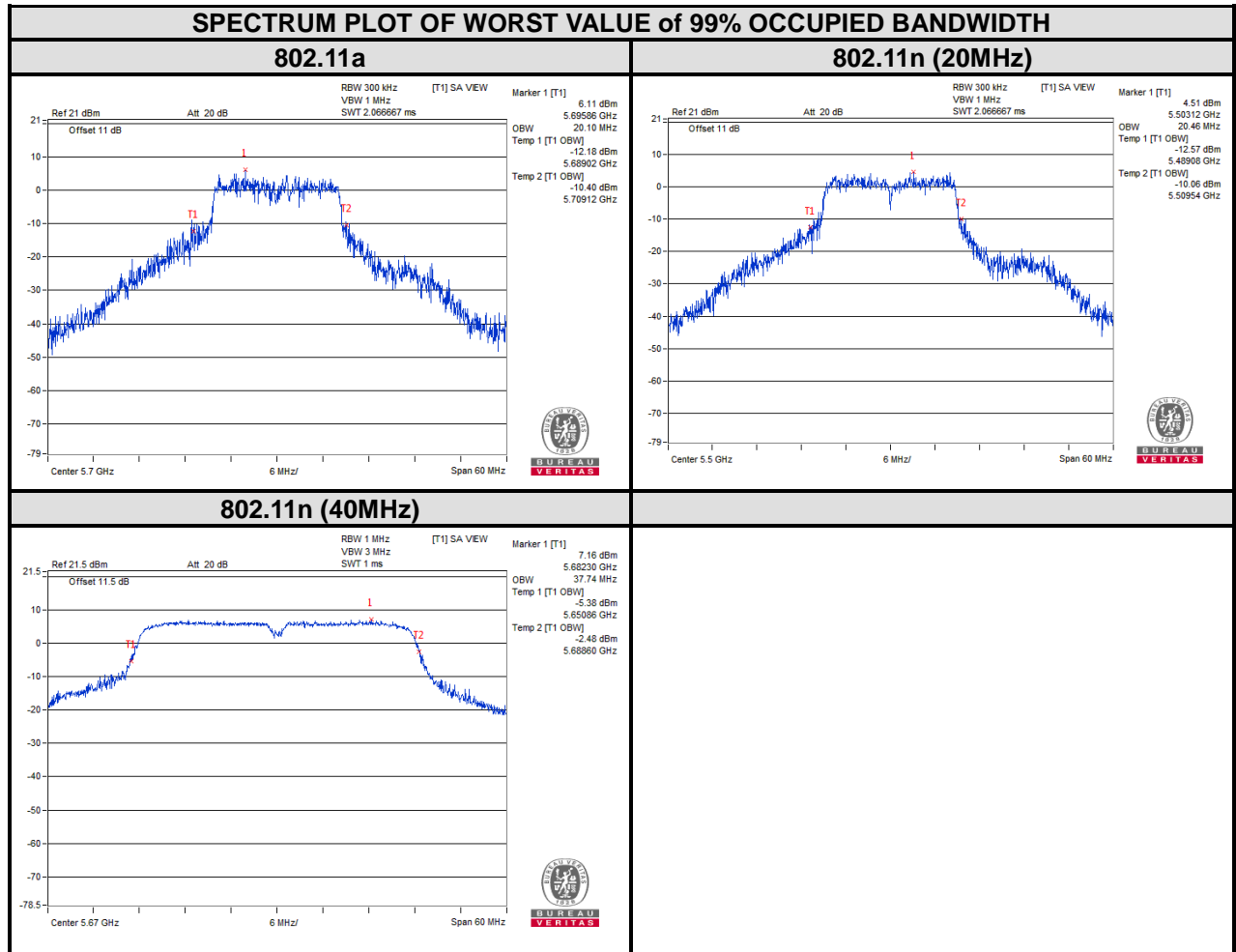



BUREAU VERITAS

Test Report No.: RF180829W002-3

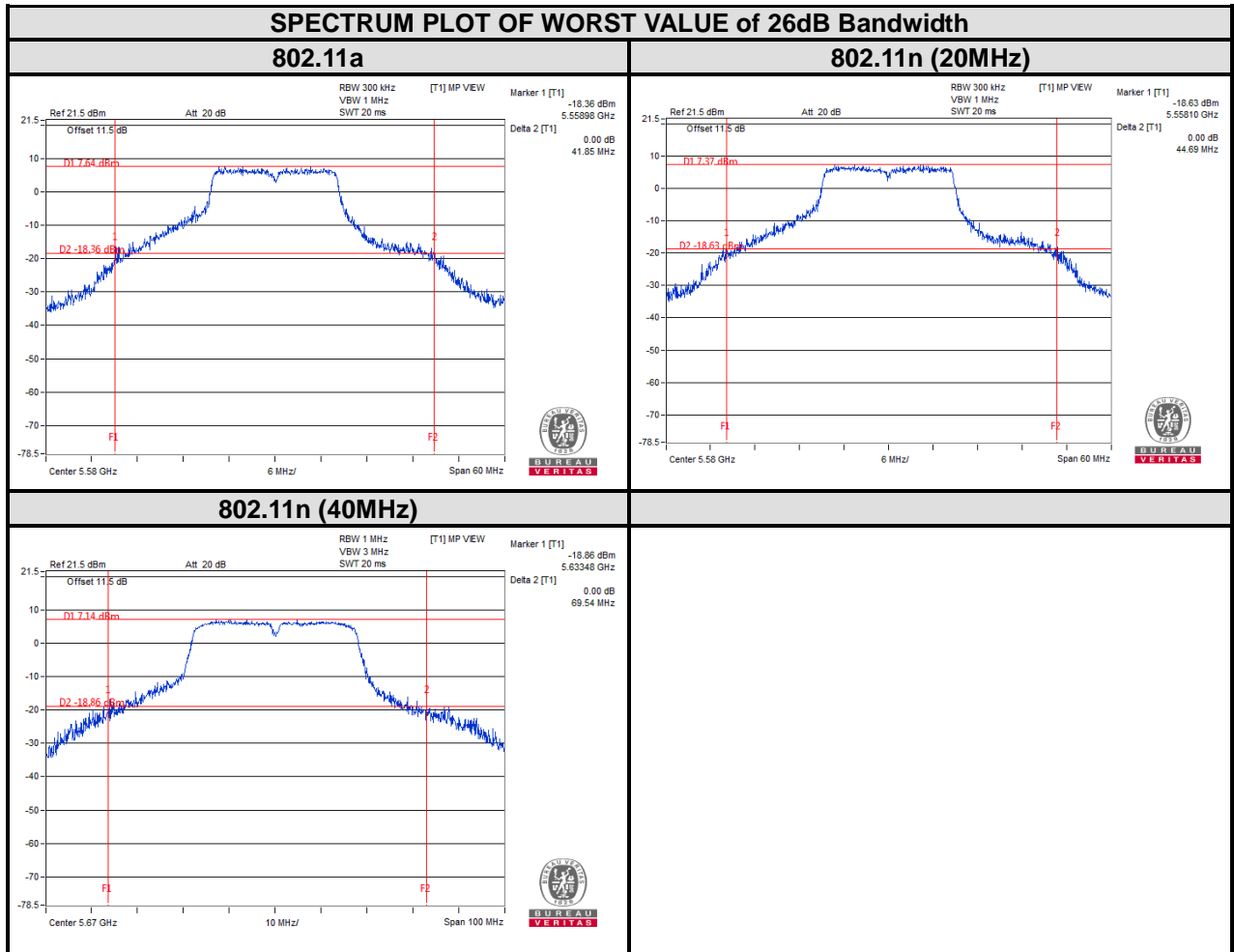



BUREAU VERITAS

Test Report No.: RF180829W002-3

For U-NII-3:

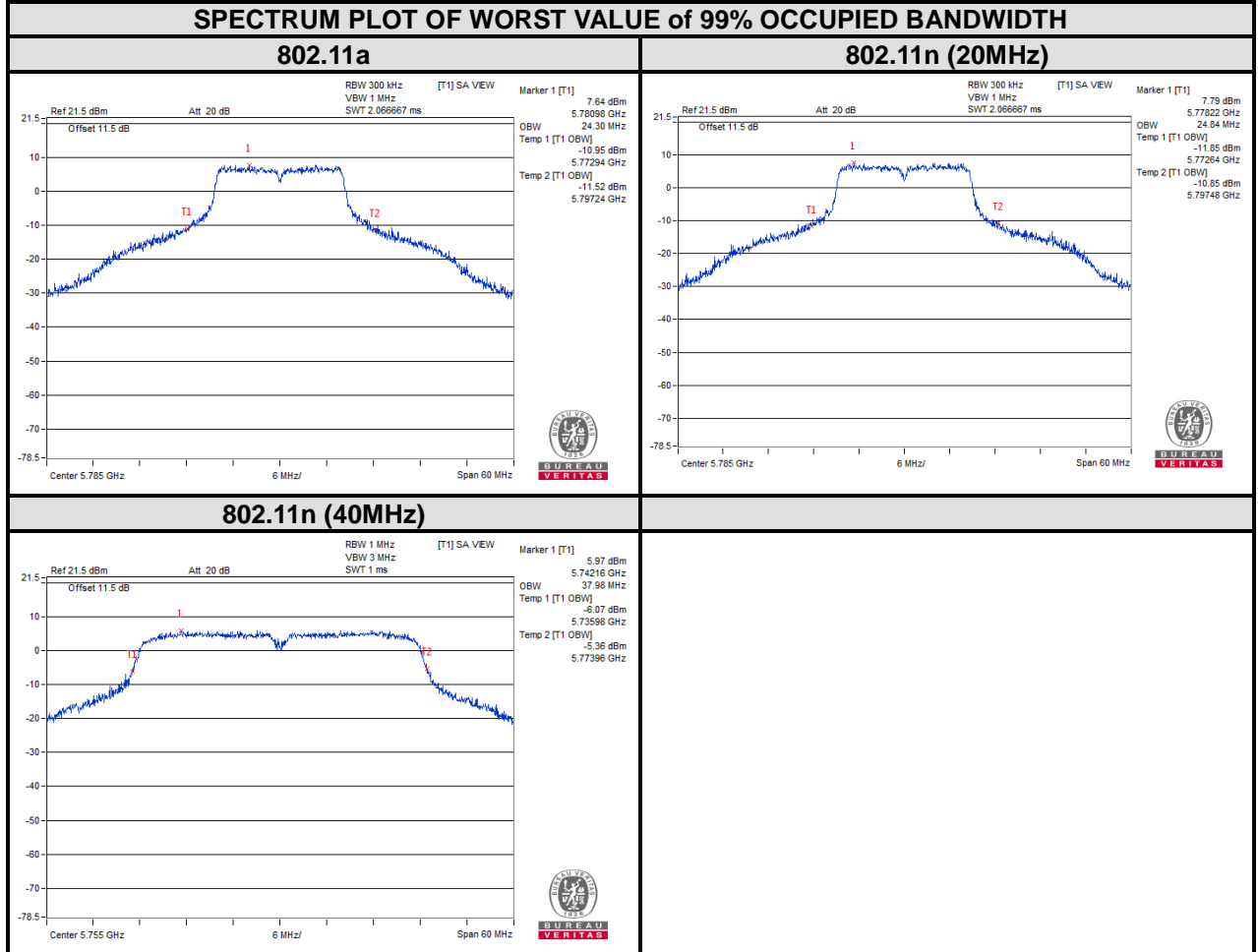



BUREAU VERITAS

Test Report No.: RF180829W002-3

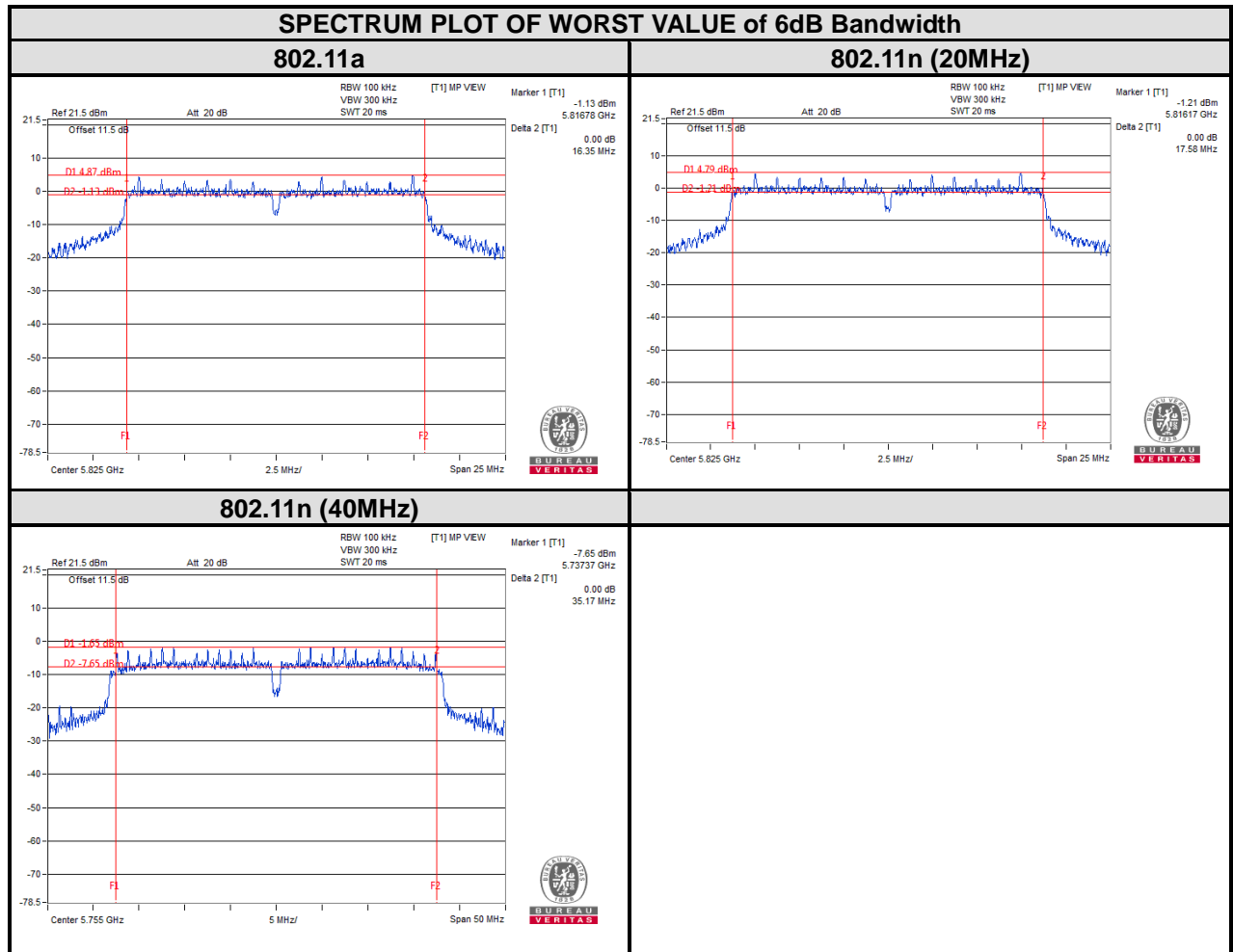



3.4 MAXIMUM POWER SPECTRAL DENSITY MEASUREMENT

3.4.1 LIMITS OF MAXIMUM POWER SPECTRAL DENSITY MEASUREMENT

Operation Band	EUT Category		LIMIT
U-NII-1		Outdoor Access Point	17dBm/ MHz
		Fixed point-to-point Access Point	
		Indoor Access Point	
	√	Client devices	11dBm/ MHz
U-NII-2A		√	11dBm/ MHz
U-NII-2C		√	11dBm/ MHz
U-NII-3		√	30dBm/ 500kHz

3.4.2 TEST SETUP

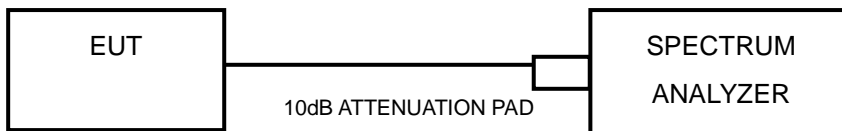

3.4.3 TEST INSTRUMENTS

Refer to section 3.3.3 to get information of above instrument.



3.4.4 TEST PROCEDURES

Using method SA-2

- 1) Set span to encompass the entire emission bandwidth (EBW) of the signal.
- 2) Set RBW = 1 MHz, Set VBW \geq 3 MHz, Detector = RMS
- 3) Set Channel power measure = 1MHz
- 4) Sweep time = auto, trigger set to "free run".
- 5) Trace average at least 100 traces in power averaging mode.
- 6) Add $10 \log(1/x)$, where x is the duty cycle, to the measured power in order to compute the average power during the actual transmission times (because the measurement represents an average over both the on and off times of the transmission).
- 7) Record the max value

3.4.5 DEVIATION FROM TEST STANDARD

No deviation.

3.4.6 EUT OPERATING CONDITIONS

Same as 3.1.6.



3.4.7 TEST RESULTS

For U-NII-1 & U-NII-2A & U-NII-2C :

802.11a

CHANNEL	FREQUENCY (MHz)	PSD w/o Duty Factor (dBm/MHz)	Duty Factor	PSD with Duty Factor (dBm/MHz)	MAXIMUM LIMIT (dBm/MHz)	PASS/FAIL
36	5180	4.72	0.60	5.32	11	PASS
40	5200	5.24	0.60	5.84	11	PASS
48	5240	6.14	0.60	6.74	11	PASS
52	5260	6.68	0.60	7.28	11	PASS
60	5300	6.70	0.60	7.30	11	PASS
64	5320	6.41	0.60	7.01	11	PASS
100	5500	7.43	0.60	8.03	11	PASS
116	5580	7.94	0.60	8.54	11	PASS
140	5700	6.48	0.60	7.08	11	PASS

802.11n (20MHz)

CHANNEL	FREQUENCY (MHz)	PSD w/o Duty Factor (dBm/MHz)	Duty Factor	PSD with Duty Factor (dBm/MHz)	MAXIMUM LIMIT (dBm/MHz)	PASS/FAIL
36	5180	5.29	0.64	5.93	11	PASS
40	5200	5.18	0.64	5.82	11	PASS
48	5240	6.62	0.64	7.26	11	PASS
52	5260	6.36	0.64	7.00	11	PASS
60	5300	6.71	0.64	7.35	11	PASS
64	5320	6.67	0.64	7.31	11	PASS
100	5500	6.92	0.64	7.56	11	PASS
116	5580	7.58	0.64	8.22	11	PASS
140	5700	7.09	0.64	7.73	11	PASS



802.11n (40MHz)

CHANNEL	FREQUENCY (MHz)	PSD w/o Duty Factor (dBm/MHz)	Duty Factor	PSD with Duty Factor (dBm/MHz)	MAXIMUM LIMIT (dBm/MHz)	PASS/FAIL
38	5190	6.21	1.21	7.42	11	PASS
46	5230	6.49	1.21	7.70	11	PASS
54	5270	6.33	1.21	7.54	11	PASS
62	5310	5.87	1.21	7.08	11	PASS
102	5510	5.04	1.21	6.25	11	PASS
110	5550	5.69	1.21	6.90	11	PASS
134	5670	4.22	1.21	5.43	11	PASS



For U-NII-3:

802.11a

CHANNEL	FREQUENCY (MHz)	PSD w/o Duty Factor (dBm/MHz)	PSD w/o Duty Factor (dBm/500kHz)	Duty Factor	PSD with Duty Factor (dBm/500kHz)	LIMIT (dBm/500kHz)	PASS /FAIL
149	5745	13.83	10.82	0.60	11.42	30	PASS
157	5785	13.96	10.95	0.60	11.55	30	PASS
165	5825	13.10	10.09	0.60	10.69	30	PASS

802.11n (20MHz)

CHANNEL	FREQUENCY (MHz)	PSD w/o Duty Factor (dBm/MHz)	PSD w/o Duty Factor (dBm/500kHz)	Duty Factor	PSD with Duty Factor (dBm/500kHz)	LIMIT (dBm/500kHz)	PASS /FAIL
149	5745	13.23	10.22	0.64	10.86	30	PASS
157	5785	13.83	10.82	0.64	11.46	30	PASS
165	5825	12.78	9.77	0.64	10.41	30	PASS

802.11n (40MHz)

CHANNEL	FREQUENCY (MHz)	PSD w/o Duty Factor (dBm/MHz)	PSD w/o Duty Factor (dBm/500kHz)	Duty Factor	PSD with Duty Factor (dBm/500kHz)	LIMIT (dBm/500kHz)	PASS /FAIL
151	5755	8.15	5.14	1.21	6.35	30	PASS
159	5795	7.53	4.52	1.21	5.73	30	PASS



BUREAU VERITAS

Test Report No.: RF180829W002-3

For 5180~5240MHz

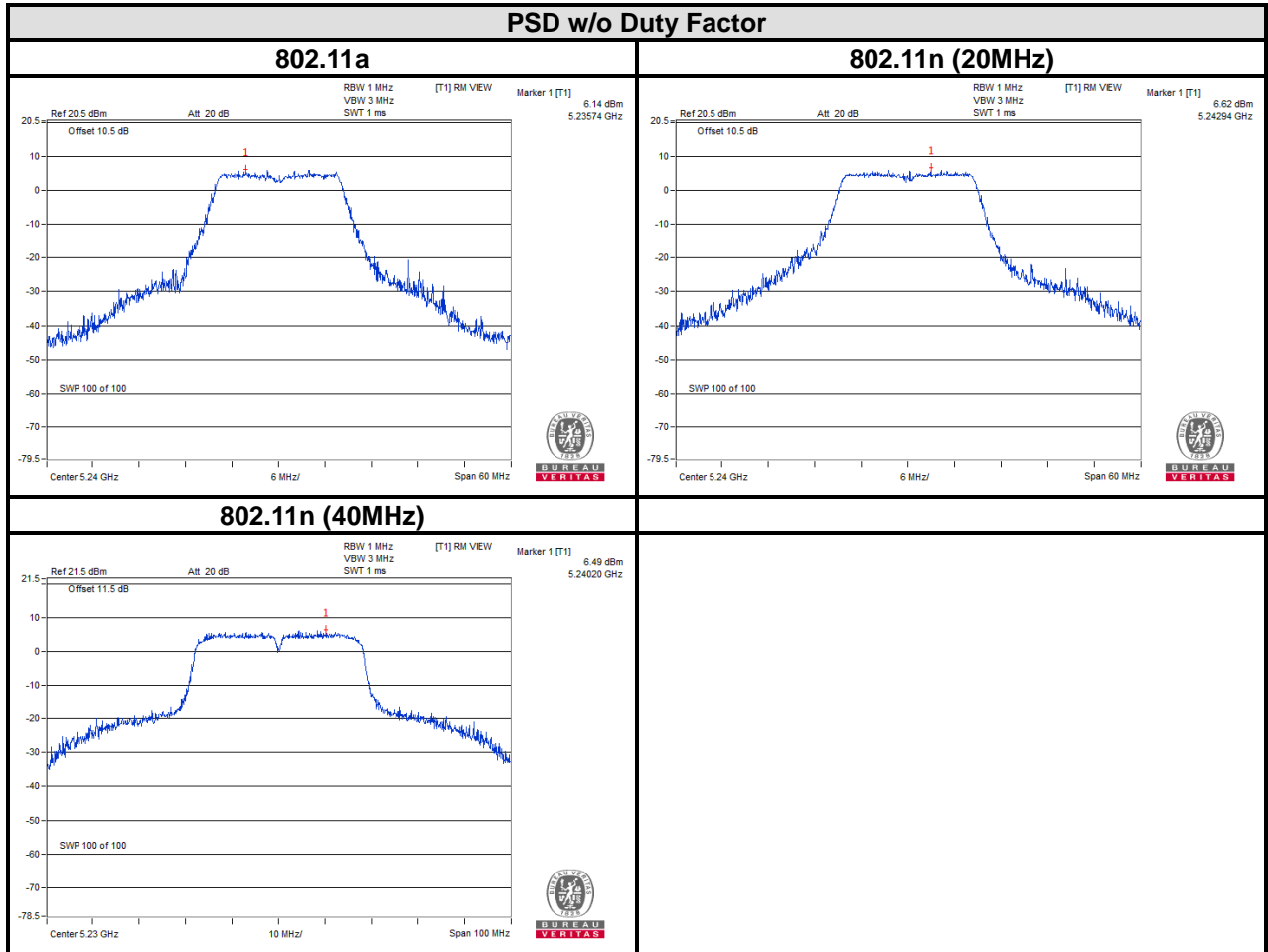



BUREAU VERITAS

Test Report No.: RF180829W002-3

For 5260~5320MHz

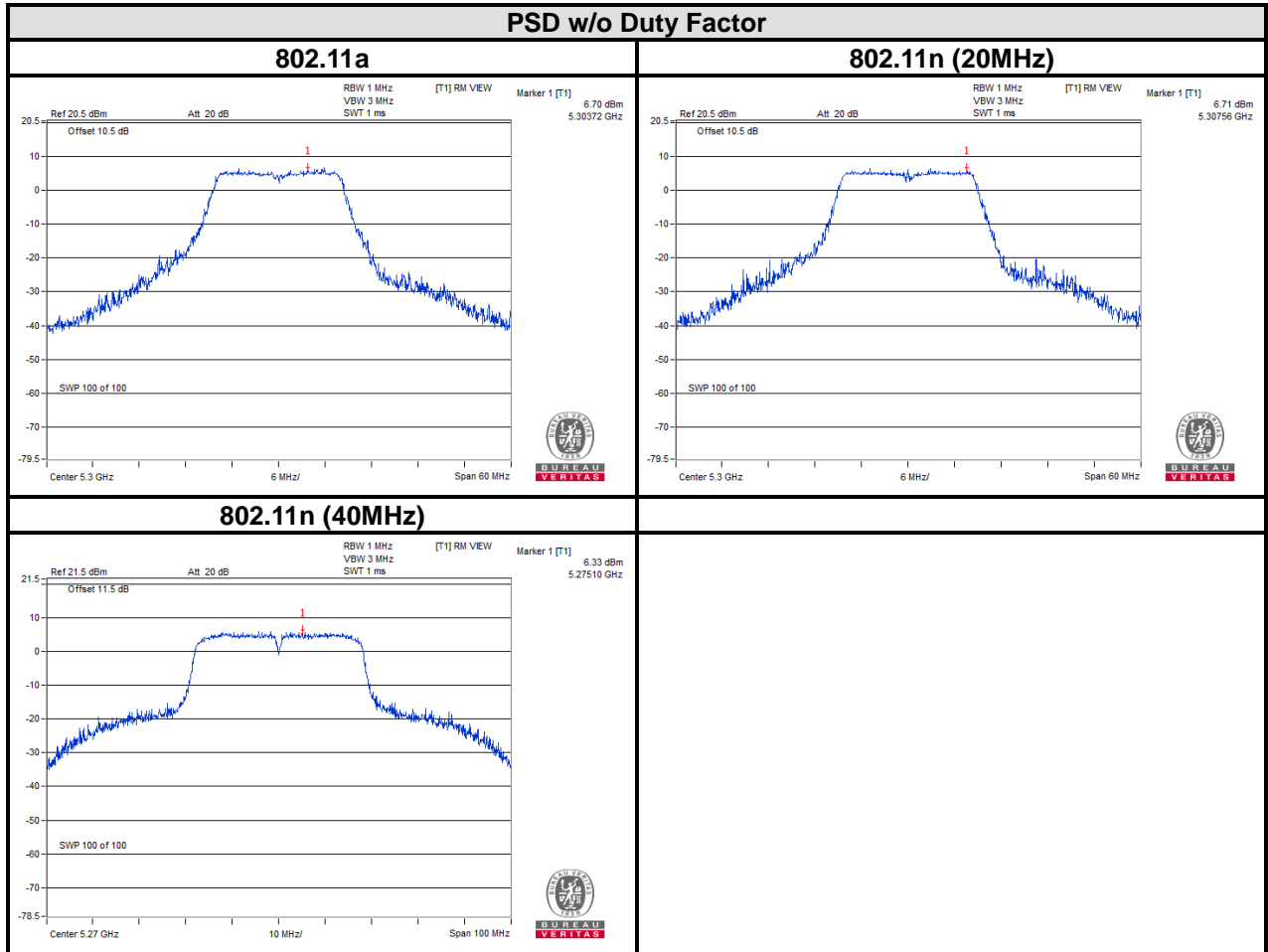



**BUREAU
VERITAS**

Test Report No.: RF180829W002-3

For 5500~5700MHz

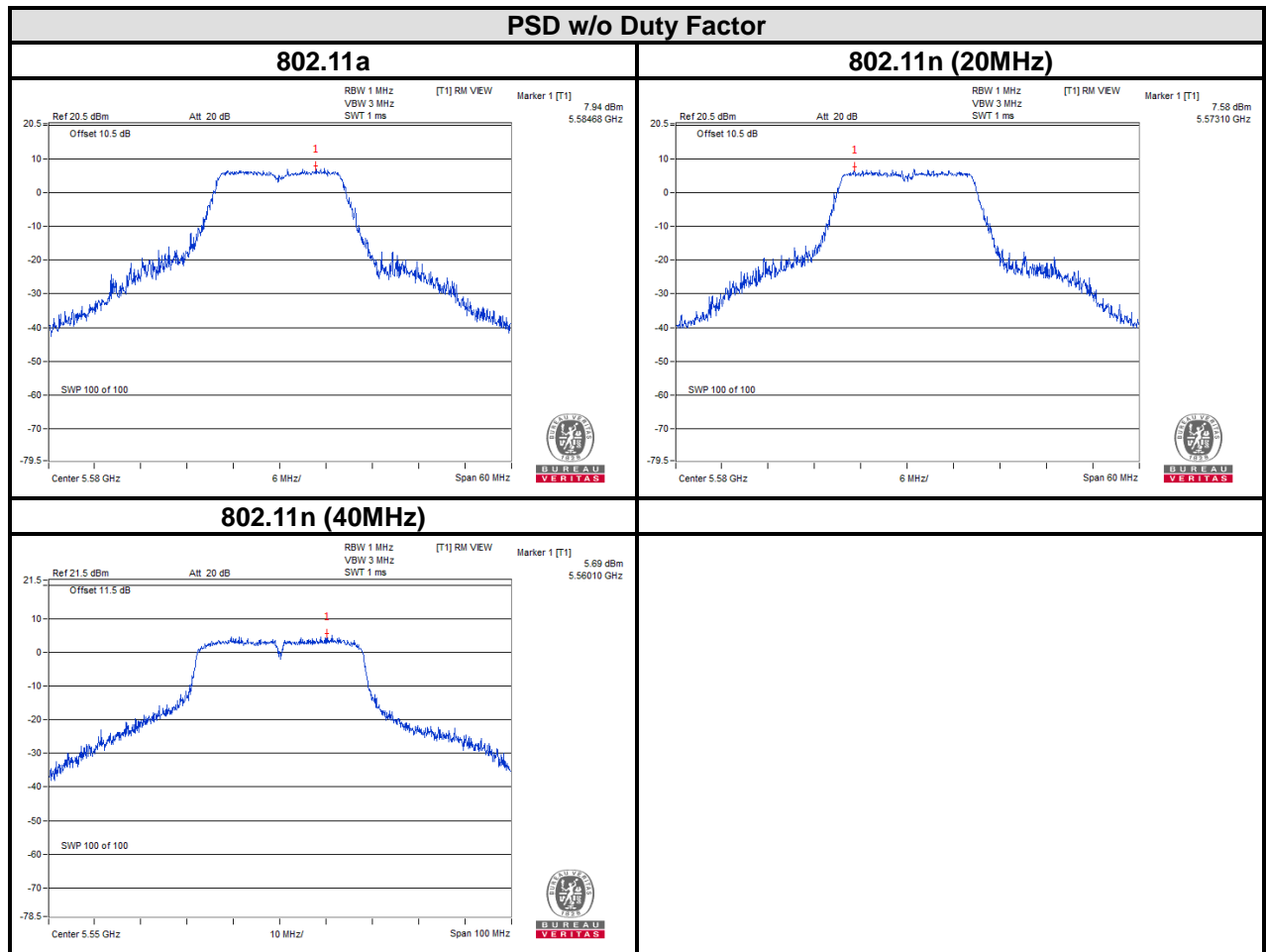



BUREAU VERITAS

Test Report No.: RF180829W002-3

For 5745~5825MHz

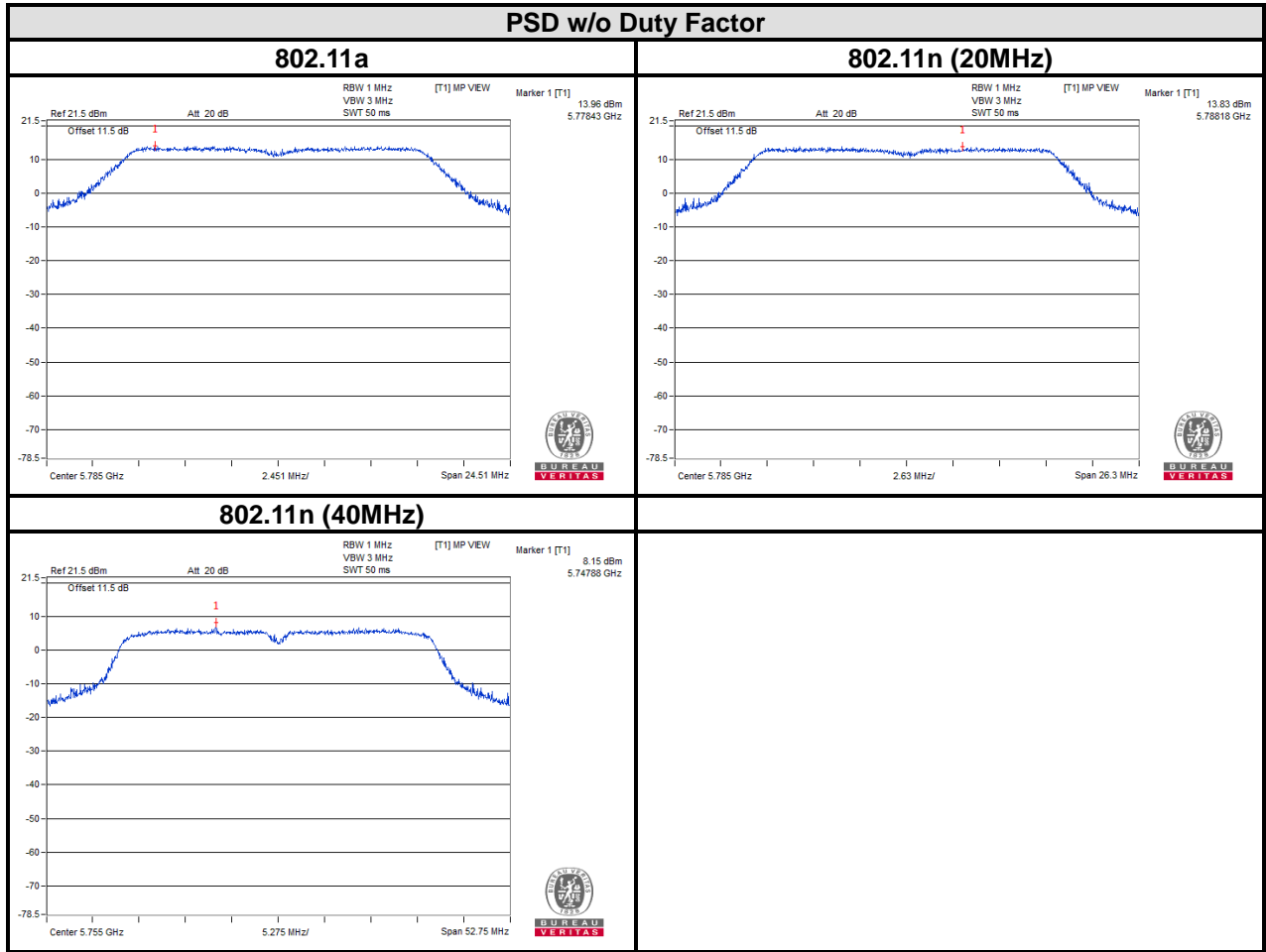



3.5 FREQUENCY STABILITY

3.5.1 LIMITS OF FREQUENCY STABILITY MEASUREMENT

The frequency of the carrier signal shall be maintained within band of operation

3.5.2 TEST SETUP

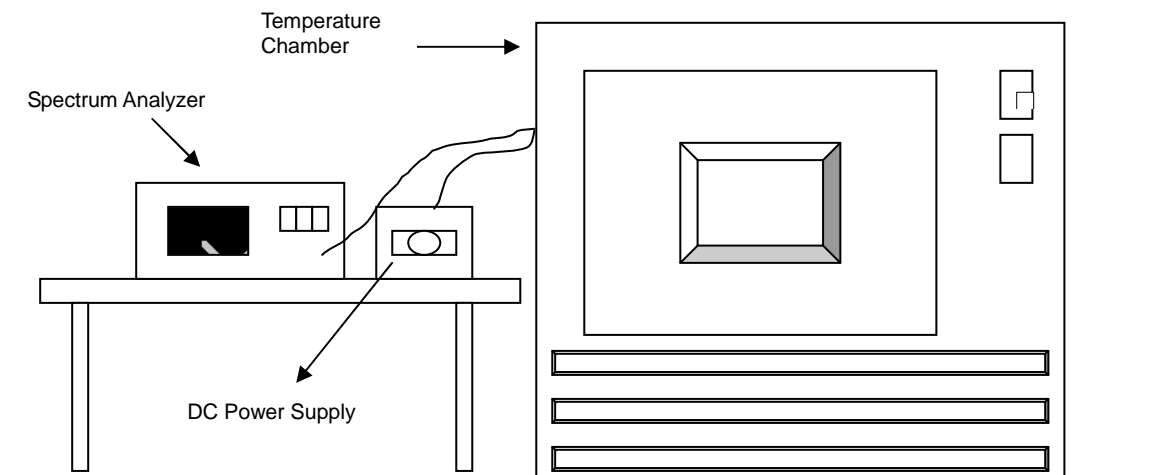

3.5.3 TEST INSTRUMENTS

Refer to section 3.3.3 to get information of above instrument.



3.5.4 TEST PROCEDURE

- a. The EUT was placed inside the environmental test chamber and powered by nominal DC voltage.
- b. Turn the EUT on and couple its output to a spectrum analyzer.
- c. Turn the EUT off and set the chamber to the highest temperature specified.
- d. Allow sufficient time (approximately 30 min) for the temperature of the chamber to stabilize, turn the EUT on and measure the operating frequency after 2, 5, and 10 minutes.
- e. Repeat step 2 and 3 with the temperature chamber set to the lowest temperature.
- f. The test chamber was allowed to stabilize at +20 degree C for a minimum of 30 minutes. The supply voltage was then adjusted on the EUT from 85% to 115% and the frequency record.

3.5.5 DEVIATION FROM TEST STANDARD

No deviation.

3.5.6 EUT OPERATING CONDITION

Set the EUT transmit at un-modulation mode to test frequency stability.



3.5.7 TEST RESULTS

FREQUENCY STABILITY VERSUS TEMP.										
OPERATING FREQUENCY: 5180MHz										
TEMP. (°C)	Power Supply (Vdc)	0 MINUTE		2 MINUTES		5 MINUTES		10 MINUTE		RESULT
		Measured Frequency (MHz)	Frequency Drift (ppm)	Measured Frequency (MHz)	Frequency Drift (ppm)	Measured Frequency (MHz)	Frequency Drift (ppm)	Measured Frequency (MHz)	Frequency Drift (ppm)	
50	120	5179.9936	-1.236	5179.9942	-1.120	5179.9941	-1.139	5179.9908	-1.776	PASS
40	120	5180.0185	3.571	5180.0217	4.189	5180.0168	3.243	5180.0209	4.035	PASS
30	120	5180.0223	4.305	5180.023	4.440	5180.0224	4.324	5180.0208	4.015	PASS
20	120	5180.0112	2.162	5180.0074	1.429	5180.0137	2.645	5180.0135	2.606	PASS
10	120	5180.0069	1.332	5180.0144	2.780	5180.0075	1.448	5180.0154	2.973	PASS
0	120	5179.9821	-3.456	5179.9788	-4.093	5179.9788	-4.093	5179.9784	-4.170	PASS
-10	120	5179.9773	-4.382	5179.974	-5.019	5179.9748	-4.865	5179.9726	-5.290	PASS
-20	120	5179.9852	-2.857	5179.9801	-3.842	5179.9775	-4.344	5179.9824	-3.398	PASS
-30	120	5179.9914	-1.660	5179.9998	-0.039	5179.999	-0.193	5179.9988	-0.232	PASS

FREQUENCY STABILITY VERSUS VOLTAGE										
OPERATING FREQUENCY: 5180MHz										
TEMP. (°C)	Power Supply (Vdc)	0 MINUTE		2 MINUTE		5 MINUTE		10 MINUTE		RESULT
		Measured Frequency (MHz)	Frequency Drift (ppm)	Measured Frequency (MHz)	Frequency Drift (ppm)	Measured Frequency (MHz)	Frequency Drift (ppm)	Measured Frequency (MHz)	Frequency Drift (ppm)	
20	138	5180.0107	2.066	5180.0087	1.680	5180.0134	2.587	5180.0132	2.548	PASS
	120	5180.0112	2.162	5180.0074	1.429	5180.0137	2.645	5180.0135	2.606	PASS
	102	5180.0116	2.239	5180.0091	1.757	5180.0146	2.819	5180.0139	2.683	PASS



FREQUENCY STABILITY VERSUS TEMP.										
OPERATING FREQUENCY: 5825MHz										
TEMP. (°C)	Power Supply (Vdc)	0 MINUTE		2 MINUTES		5 MINUTES		10 MINUTE		RESULT
		Measured Frequency (MHz)	Frequency Drift (ppm)	Measured Frequency (MHz)	Frequency Drift (ppm)	Measured Frequency (MHz)	Frequency Drift (ppm)	Measured Frequency (MHz)	Frequency Drift (ppm)	
50	120	5825.0294	5.047	5825.0259	4.446	5825.0251	4.309	5825.0249	4.275	PASS
40	120	5824.9845	-2.661	5824.9902	-1.682	5824.9895	-1.803	5824.9826	-2.987	PASS
30	120	5824.9991	-0.155	5825.0016	0.275	5825.0023	0.395	5825.0071	1.219	PASS
20	120	5825.0192	3.296	5825.0199	3.416	5825.02	3.433	5825.024	4.120	PASS
10	120	5825.0108	1.854	5825.0137	2.352	5825.0182	3.124	5825.0144	2.472	PASS
0	120	5825.0235	4.034	5825.0185	3.176	5825.0196	3.365	5825.0273	4.687	PASS
-10	120	5825.0112	1.923	5825.0132	2.266	5825.0206	3.536	5825.0142	2.438	PASS
-20	120	5825.018	3.090	5825.0155	2.661	5825.0153	2.627	5825.0135	2.318	PASS
-30	120	5824.9952	-0.824	5825.0006	0.103	5824.9937	-1.082	5824.9934	-1.133	PASS

FREQUENCY STABILITY VERSUS VOLTAGE										
OPERATING FREQUENCY: 5825MHz										
TEMP. (°C)	Power Supply (Vdc)	0 MINUTE		2 MINUTE		5 MINUTE		10 MINUTE		RESULT
		Measured Frequency (MHz)	Frequency Drift (ppm)	Measured Frequency (MHz)	Frequency Drift (ppm)	Measured Frequency (MHz)	Frequency Drift (ppm)	Measured Frequency (MHz)	Frequency Drift (ppm)	
20	138	5825.0182	3.124	5825.0185	3.176	5825.0201	3.451	5825.0245	4.206	PASS
	120	5825.0192	3.296	5825.0199	3.416	5825.02	3.433	5825.024	4.120	PASS
	102	5825.0171	2.936	5825.0187	3.210	5825.021	3.605	5825.0258	4.429	PASS



Test Report No.: RF180829W002-3

4 PHOTOGRAPHS OF THE TEST CONFIGURATION

Please refer to the attached file (Test Setup Photo).



Test Report No.: RF180829W002-3

5 APPENDIX A – MODIFICATIONS RECORDERS FOR ENGINEERING CHANGES TO THE EUT BY THE LAB

No modifications were made to the EUT by the lab during the test.

---END---