

4.6 Spurious Measurement (Conducted)

Specifications:	15.209(a) and 15.205(a)					
Date of Test	2011-09-26					
Test conditions:	Ambient Temperature:15℃-35℃ Relative Humidity:30%-60% Air pressure: 86-106kPa					
Operation Mode	Fix channel transmit					
Test Results:	Pass					
Test equipment Used:						
Asset Number	Description	Manufacturer	Model Number	Serial Number	Cal Due	State
7805	EMI Test Receiver	R/S	ESI40	839283/007	2012-02-15	Normal
7330	BLUETOOTH TESTER	R/S	CBT	100657	2012-01-28	Normal

LIMIT

In any 100 kHz bandwidth outside the frequency band in which the spread spectrum or digitally modulated intentional radiator is operating, the radio frequency power that is produced by the intentional radiator shall be at least 20 dB below that in the 100 kHz bandwidth within the band that contains the highest level of the desired power, based on either an RF conducted or a radiated measurement. Attenuation below the general limits specified in Section 15.209(a) is not required. In addition, radiated emissions which fall in the restricted bands, as defined in Section 15.205(a), must also comply with the radiated emission limits specified in Section 15.209(a) (see Section 15.205(c)).

Test Setup

The BLUETOOTH TESTER was used to set the TX channel and power level. The transmitter output is connected to Spectrum analyzer through a coupling.

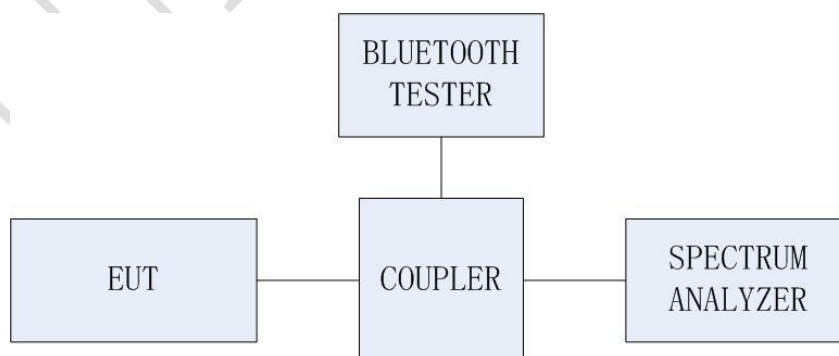

TEST PROCEDURE

Conducted RF measurements of the transmitter output were made to confirm that the EUT antenna port conducted emissions meet the specified limit and to identify any spurious signals that require further investigation or measurements on the radiated emissions site. The transmitter output is connected to the

spectrum analyzer. The resolution bandwidth is set to 100 KHz. The video bandwidth is set to 300 KHz. Measurements are made over the 30 MHz to 26 GHz range with the transmitter set to the lowest, middle, and highest channels.

The measurement is made according to Public notice FCC Public Notice DA 00-705, March 2000, and ANSI C63.4-2003.

Test Result:

GFSK

Channel	Frequency Range	Results
0	Center Frequency	Pass
	30 MHz – 1 GHz	Pass
	1 GHz – 3 GHz	Pass
	3 GHz – 10 GHz	Pass
	10 GHz – 26.5 GHz	Pass
39	Center Frequency	Pass
	30 MHz – 1 GHz	Pass
	1 GHz – 3 GHz	Pass
	3 GHz – 10 GHz	Pass
	10 GHz – 26.5 GHz	Pass
78	Center Frequency	Pass
	30 MHz – 1 GHz	Pass
	1 GHz – 3 GHz	Pass
	3 GHz – 10 GHz	Pass
	10 GHz – 26.5 GHz	Pass

Pi/4 DQPSK

Channel	Frequency Range	Results
0	Center Frequency	Pass
	30 MHz – 1 GHz	Pass
	1 GHz – 3 GHz	Pass
	3 GHz – 10 GHz	Pass
	10 GHz – 26.5 GHz	Pass

39	Center Frequency	Pass
	30 MHz – 1 GHz	Pass
	1 GHz – 3 GHz	Pass
	3 GHz – 10 GHz	Pass
	10 GHz – 26.5 GHz	Pass
78	Center Frequency	Pass
	30 MHz – 1 GHz	Pass
	1 GHz – 3 GHz	Pass
	3 GHz – 10 GHz	Pass
	10 GHz – 26.5 GHz	Pass

8DPSK

Channel	Frequency Range	Results
0	Center Frequency	Pass
	30 MHz – 1 GHz	Pass
	1 GHz – 3 GHz	Pass
	3 GHz – 10 GHz	Pass
	10 GHz – 26.5 GHz	Pass
39	Center Frequency	Pass
	30 MHz – 1 GHz	Pass
	1 GHz – 3 GHz	Pass
	3 GHz – 10 GHz	Pass
	10 GHz – 26.5 GHz	Pass
78	Center Frequency	Pass
	30 MHz – 1 GHz	Pass
	1 GHz – 3 GHz	Pass
	3 GHz – 10 GHz	Pass
	10 GHz – 26.5 GHz	Pass

Test plots:
GFSK Channel 0

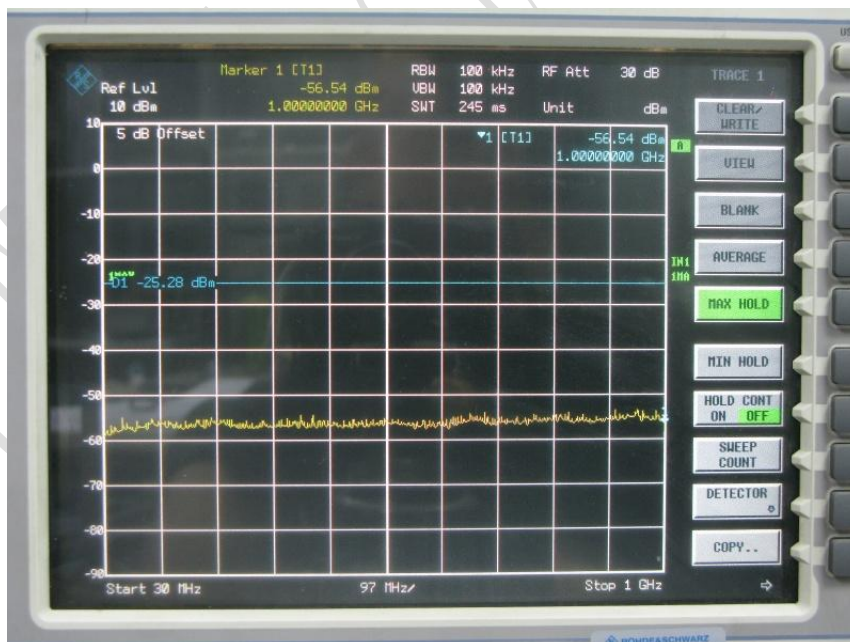

FCC Parts 15 subpart C, ANSI C63.4-2003, FCC DA 00-705
 Equipment: Sonim XP3300-A-X1

REPORT NO.: I11GC0421-FCC-BT-3

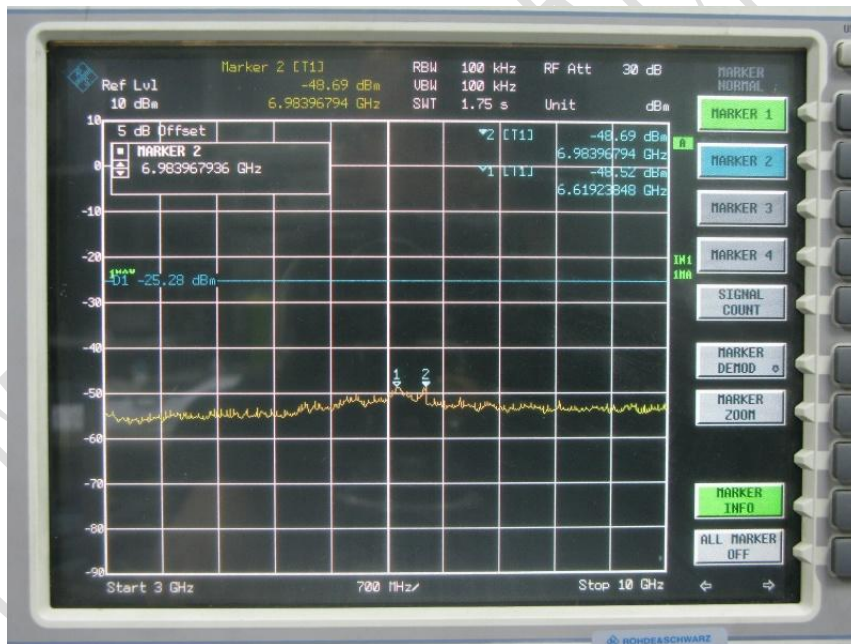
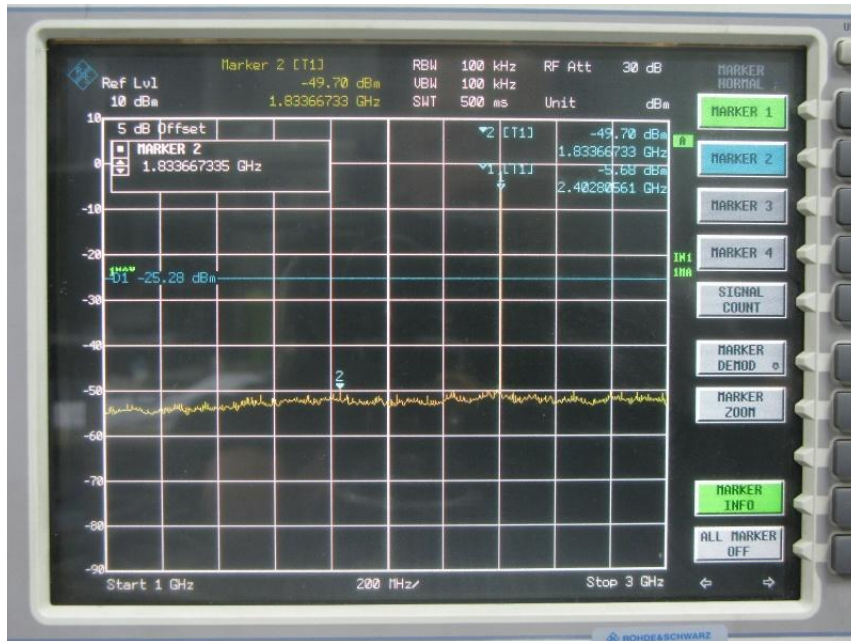

FCC Parts 15 subpart C, ANSI C63.4-2003, FCC DA 00-705
Equipment: Sonim XP3300-A-X1

REPORT NO.: I11GC0421-FCC-BT-3

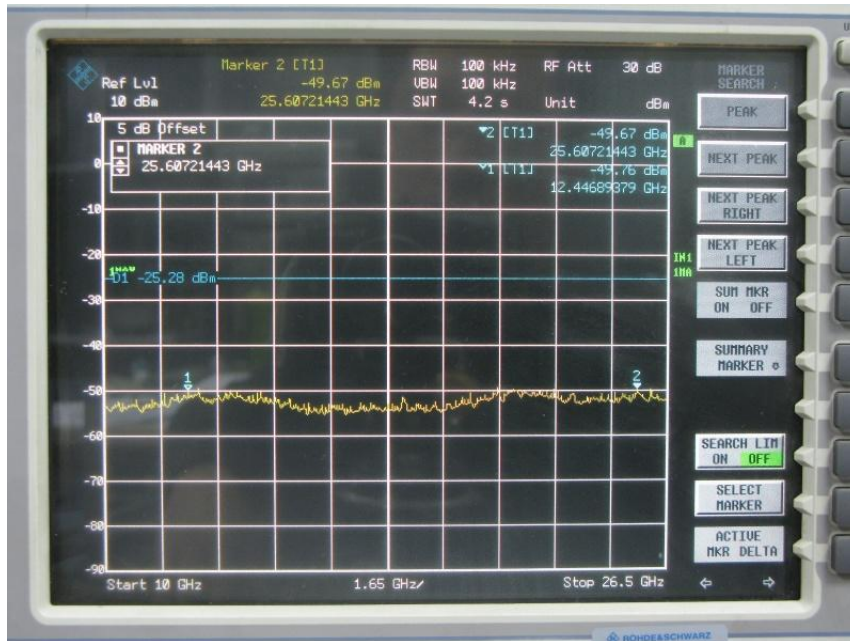

GFSK Channel 39

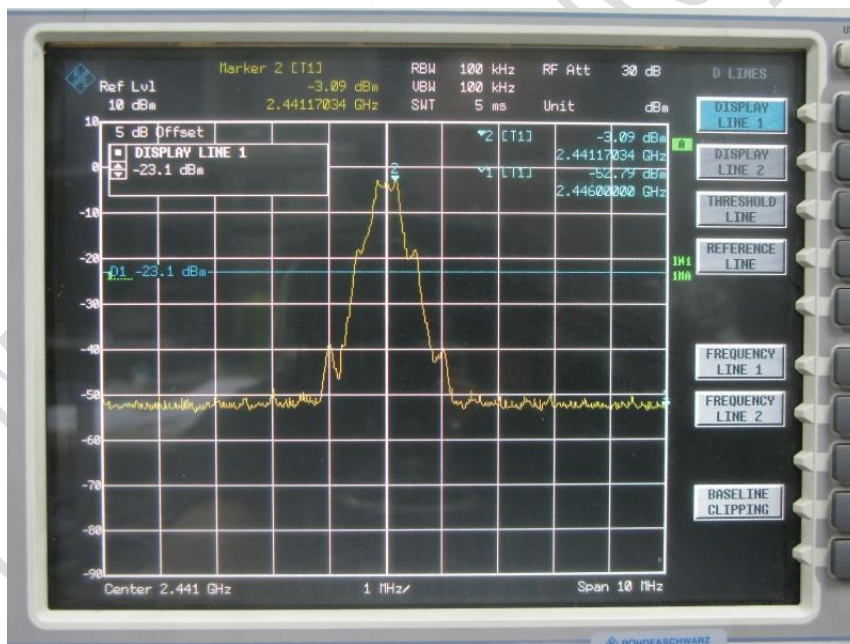

FCC Parts 15 subpart C, ANSI C63.4-2003, FCC DA 00-705
 Equipment: Sonim XP3300-A-X1

REPORT NO.: I11GC0421-FCC-BT-3

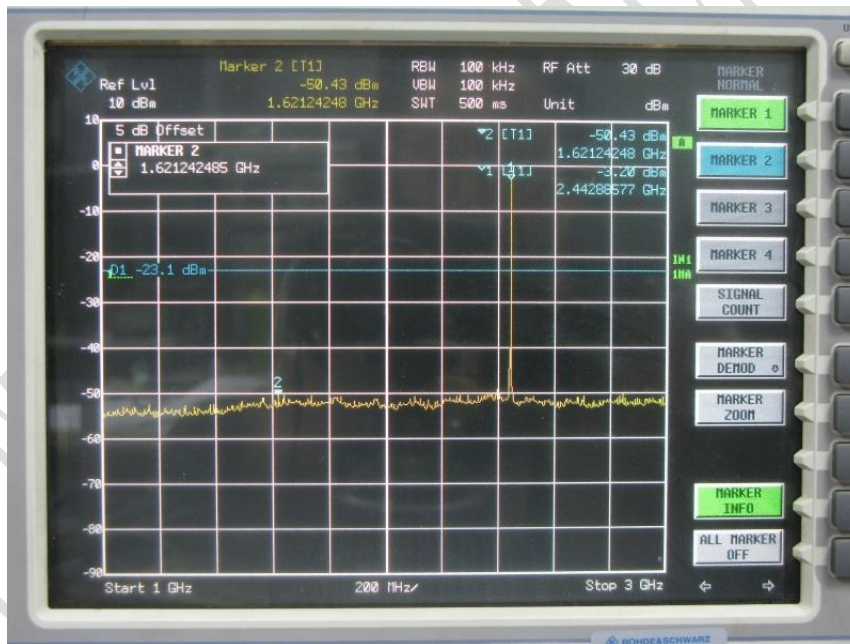
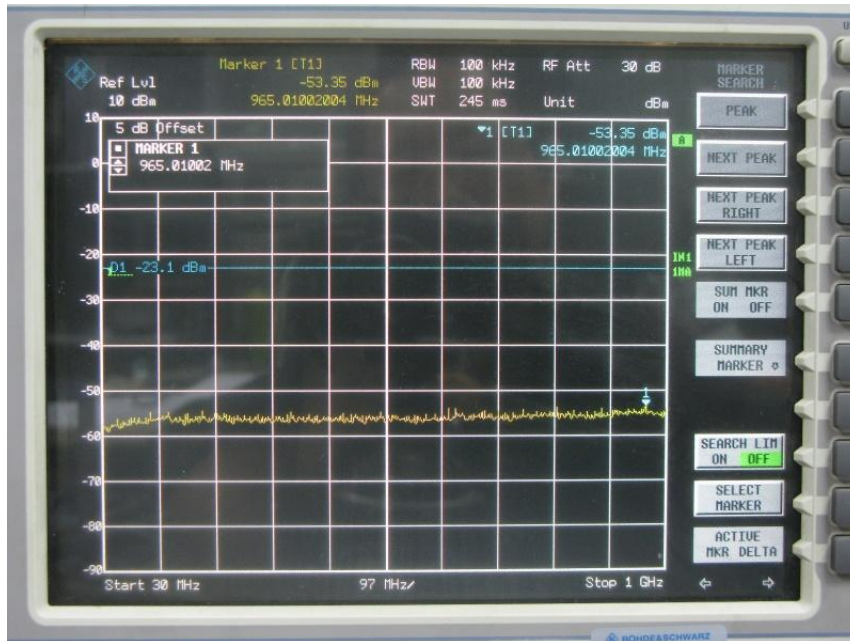

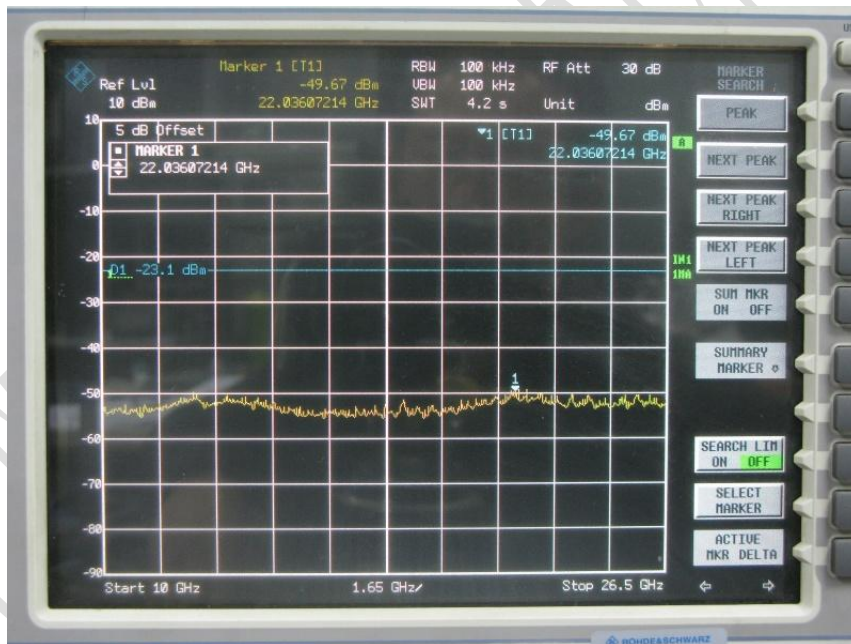
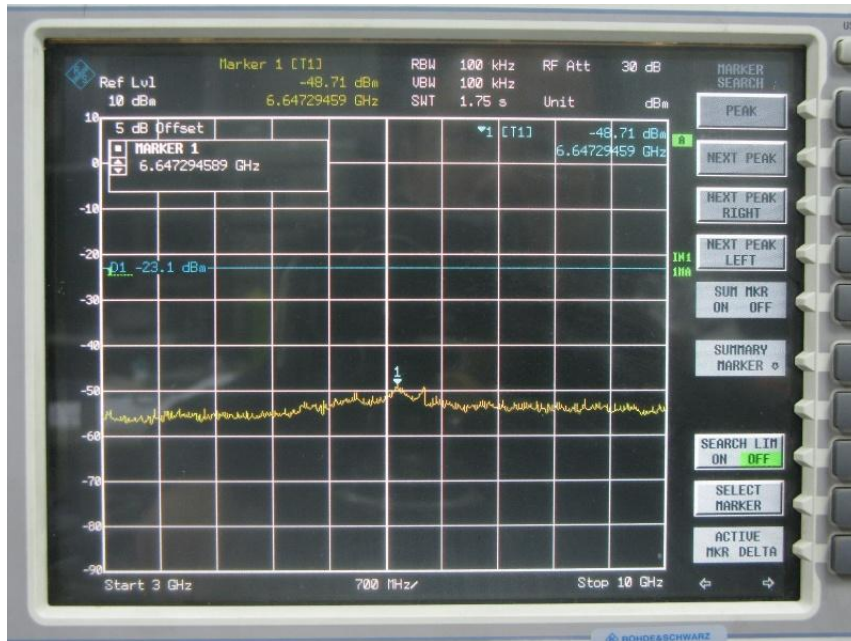

GFSK Channel 78

FCC Parts 15 subpart C, ANSI C63.4-2003, FCC DA 00-705
 Equipment: Sonim XP3300-A-X1

REPORT NO.: I11GC0421-FCC-BT-3

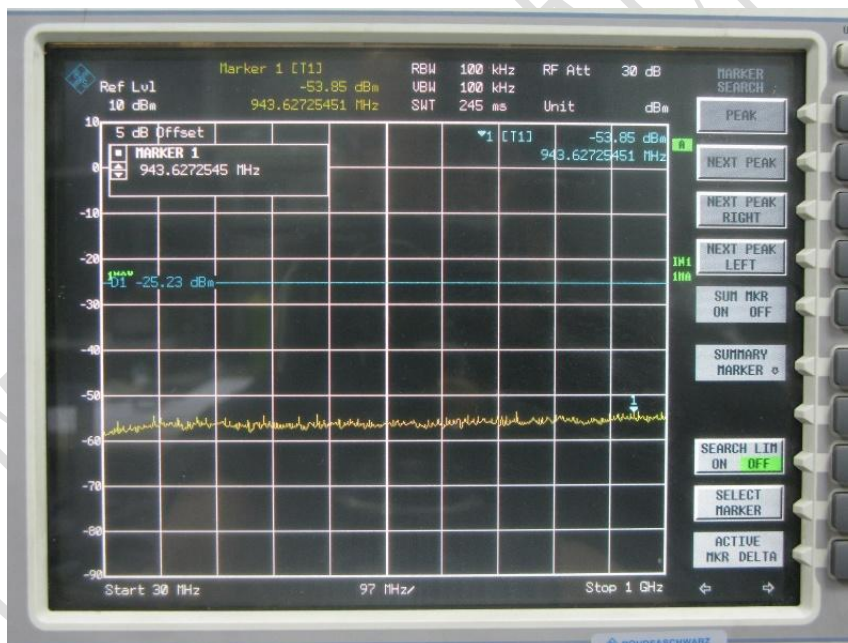
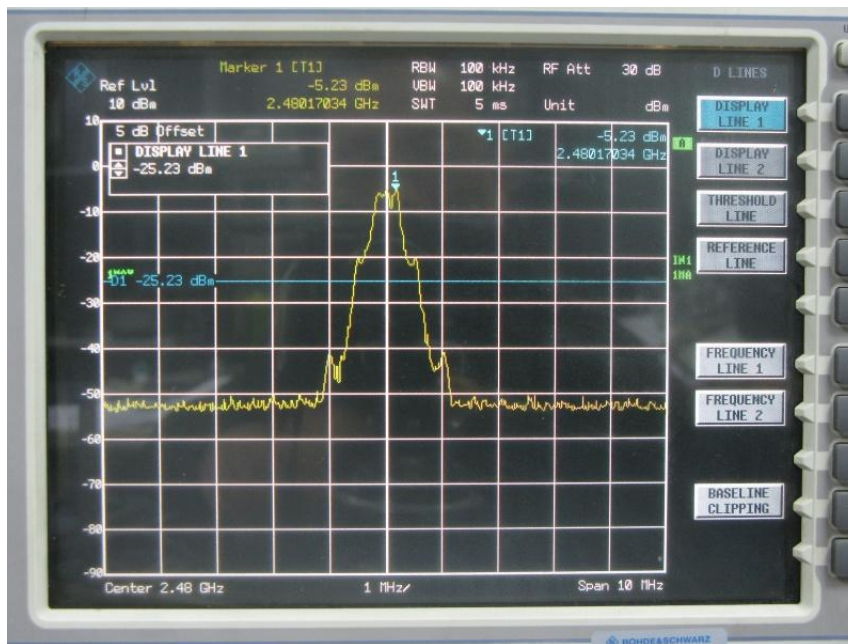

FCC Parts 15 subpart C, ANSI C63.4-2003, FCC DA 00-705
 Equipment: Sonim XP3300-A-X1

REPORT NO.: I11GC0421-FCC-BT-3

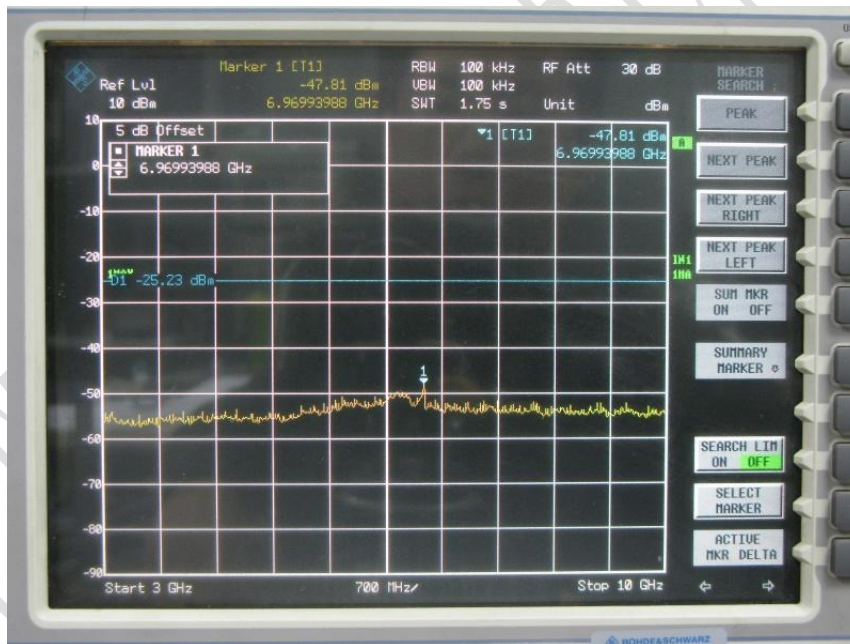
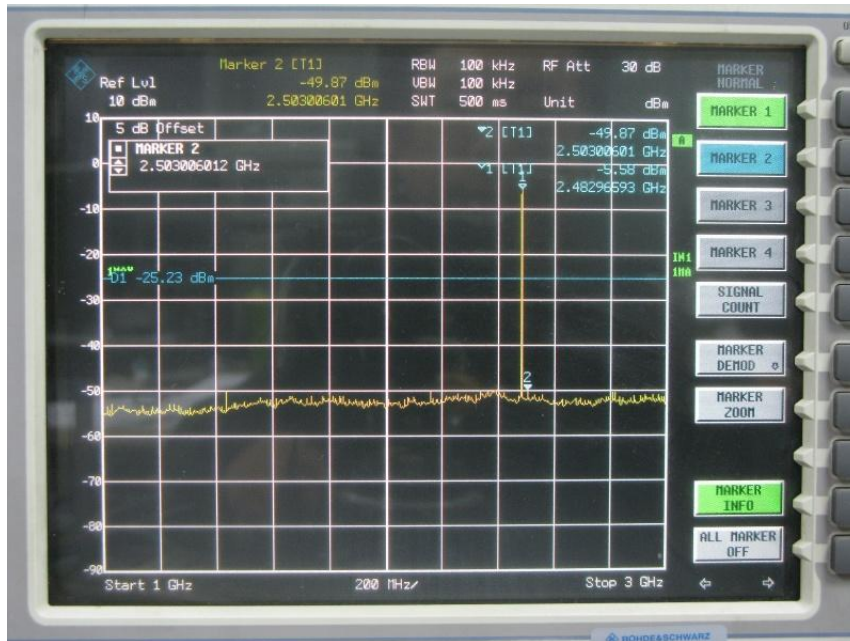

FCC Parts 15 subpart C, ANSI C63.4-2003, FCC DA 00-705
 Equipment: Sonim XP3300-A-X1

REPORT NO.: I11GC0421-FCC-BT-3

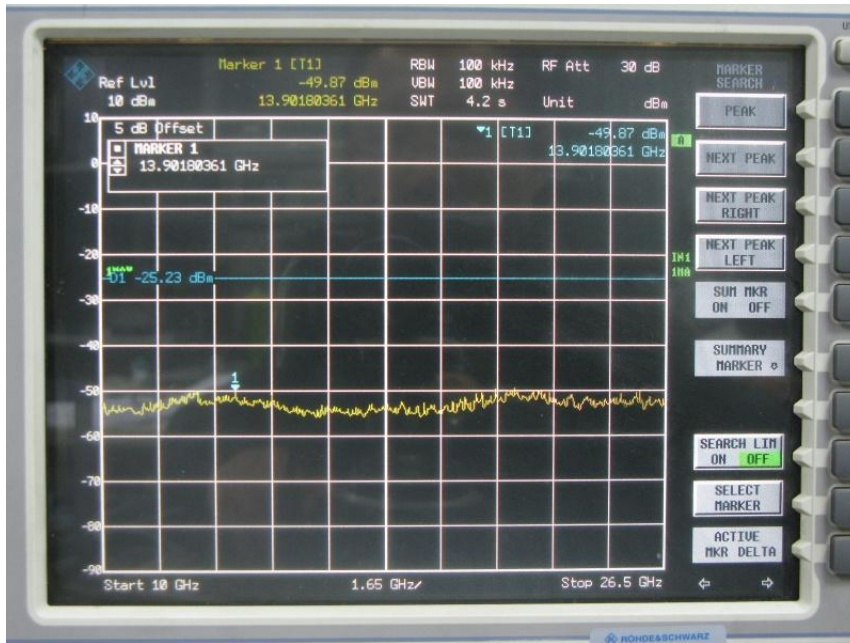

Pi/4 DQPSK Channel 0

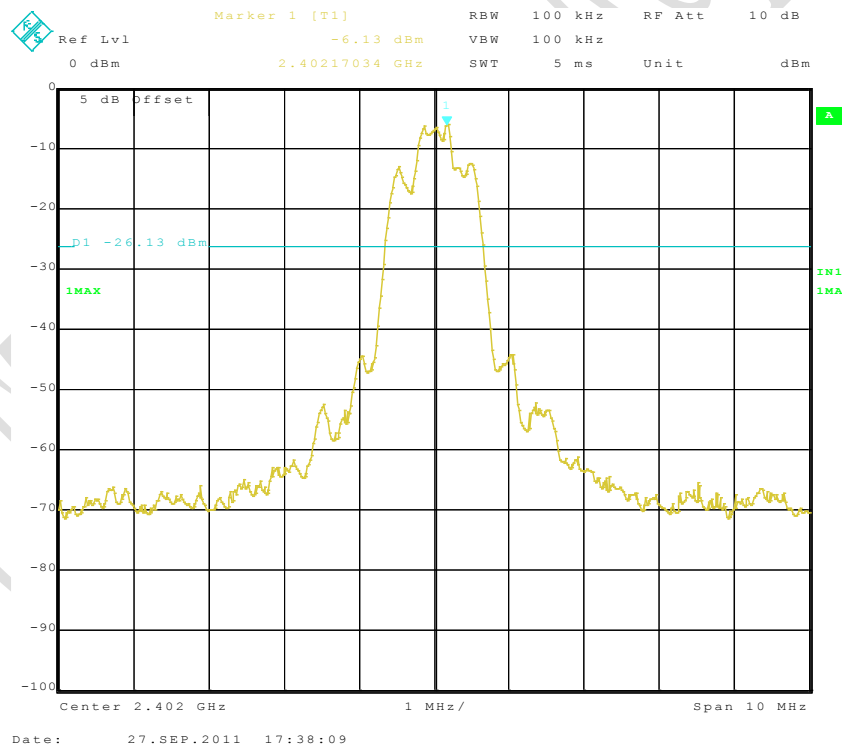

FCC Parts 15 subpart C, ANSI C63.4-2003, FCC DA 00-705
 Equipment: Sonim XP3300-A-X1

REPORT NO.: I11GC0421-FCC-BT-3

1/3
 Marker 1 [T1]
 RBW 100 kHz RF Att 10 dB
 Ref Lvl -63.07 dBm
 VBW 100 kHz
 0 dBm
 SWT 245 ms Unit dBm

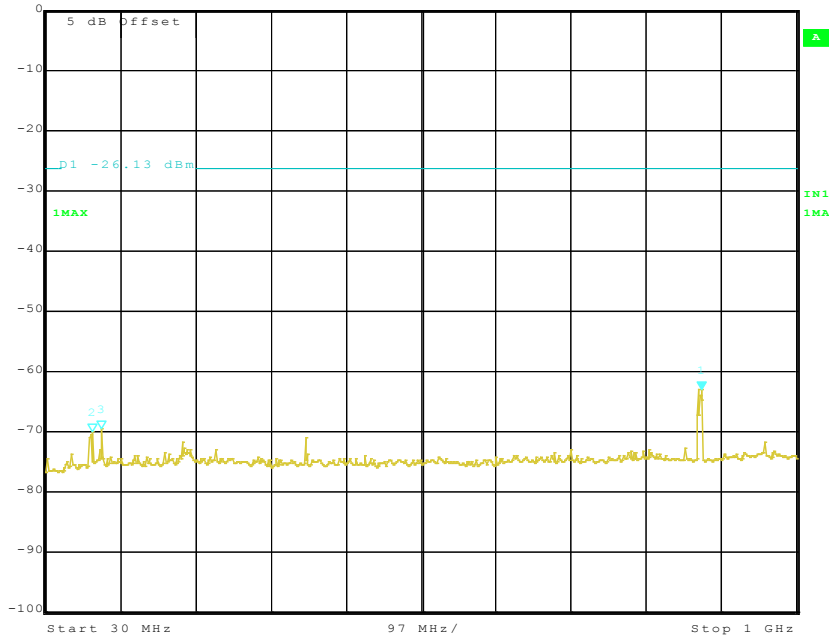

Date: 27.SEP.2011 17:45:53

2/3
 Marker 2 [T1]
 RBW 100 kHz RF Att 10 dB
 Ref Lvl -60.87 dBm
 VBW 100 kHz
 0 dBm
 SWT 640 ms Unit dBm

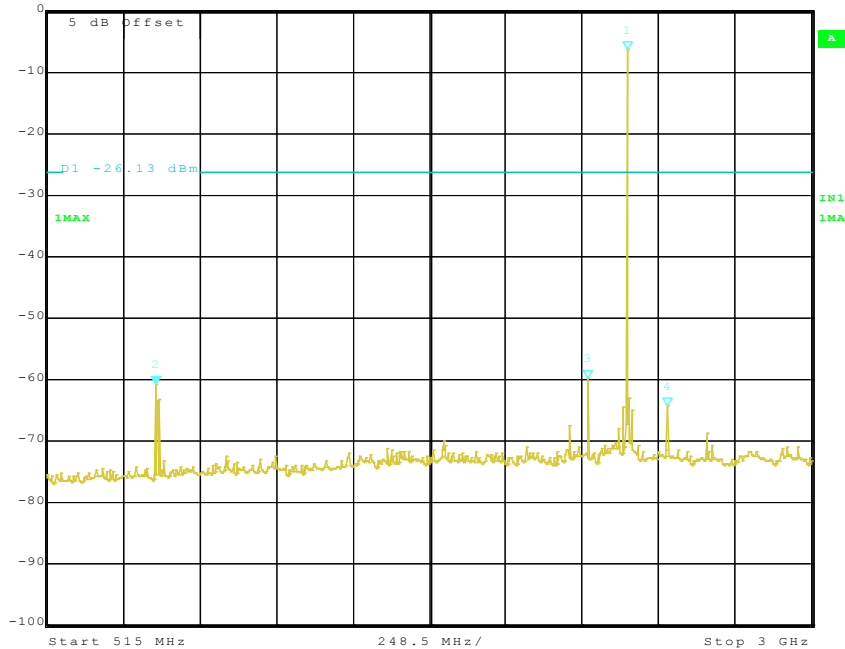

Date: 27.SEP.2011 18:32:16

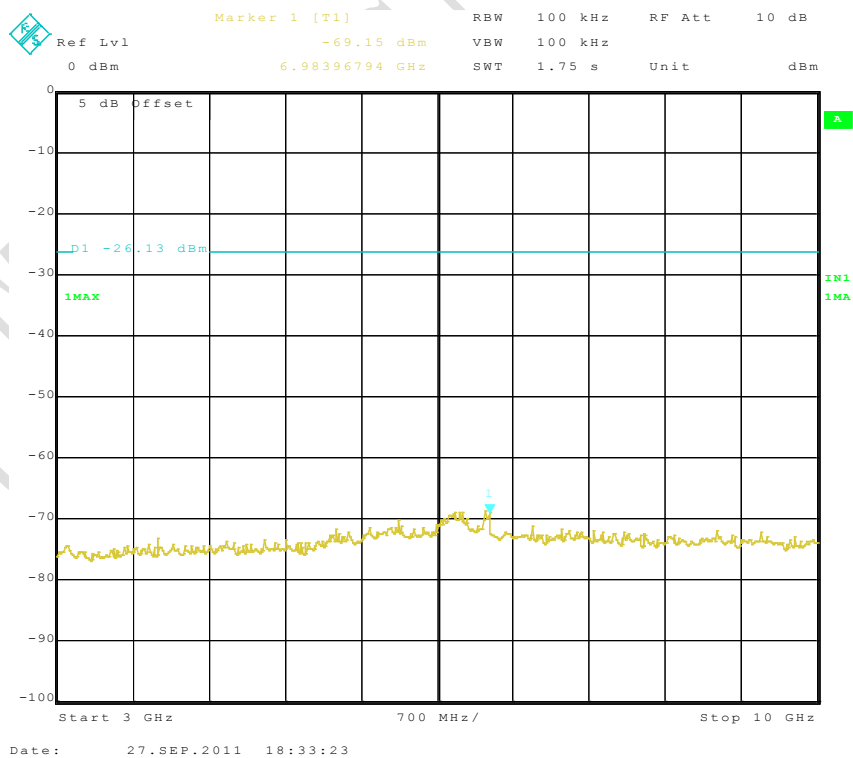
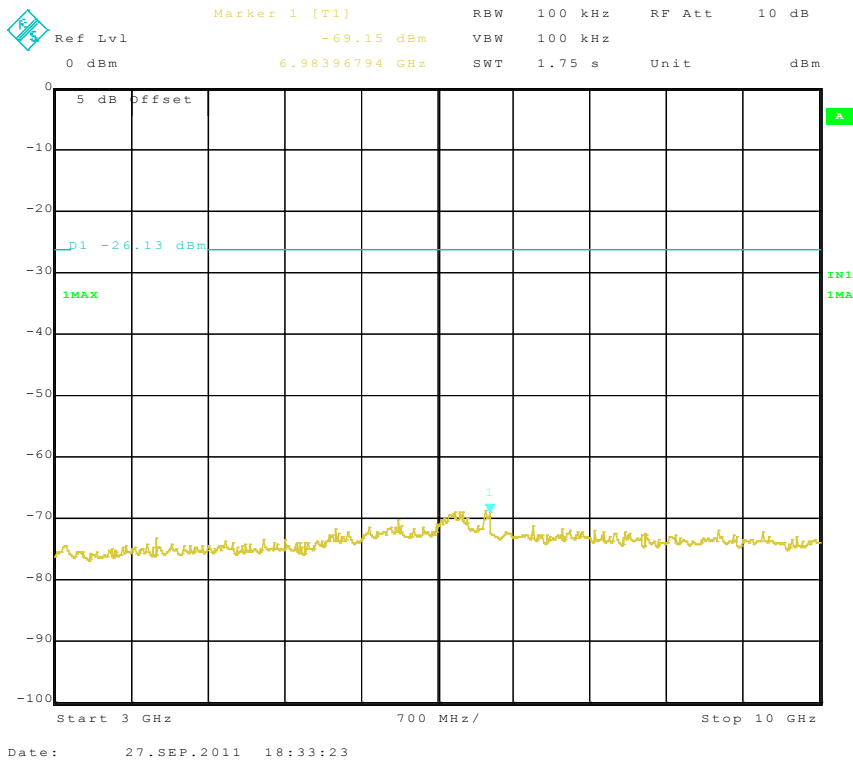

Pi/4 DQPSK Channel 39

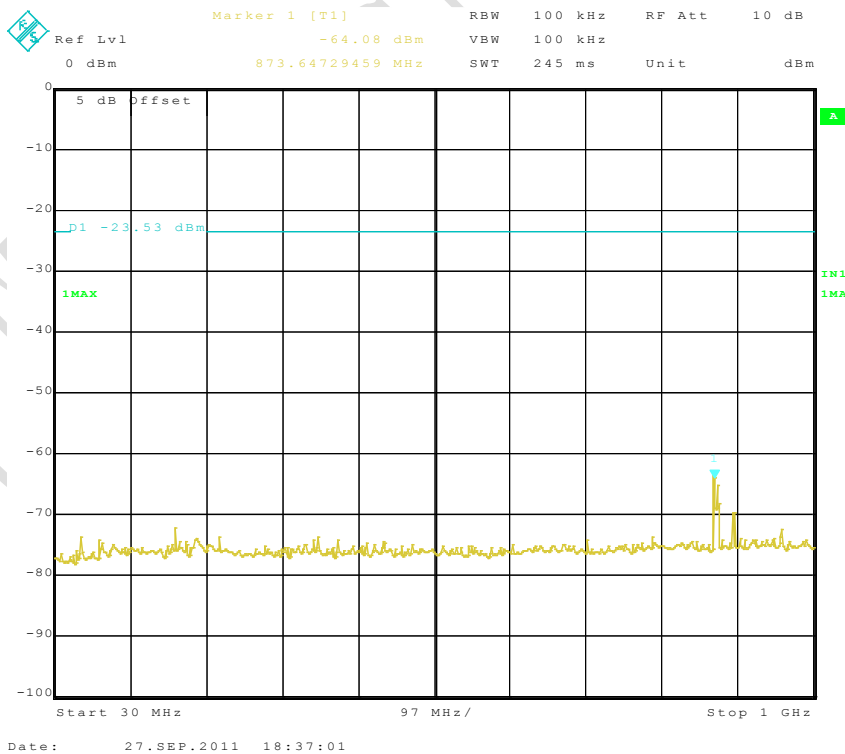
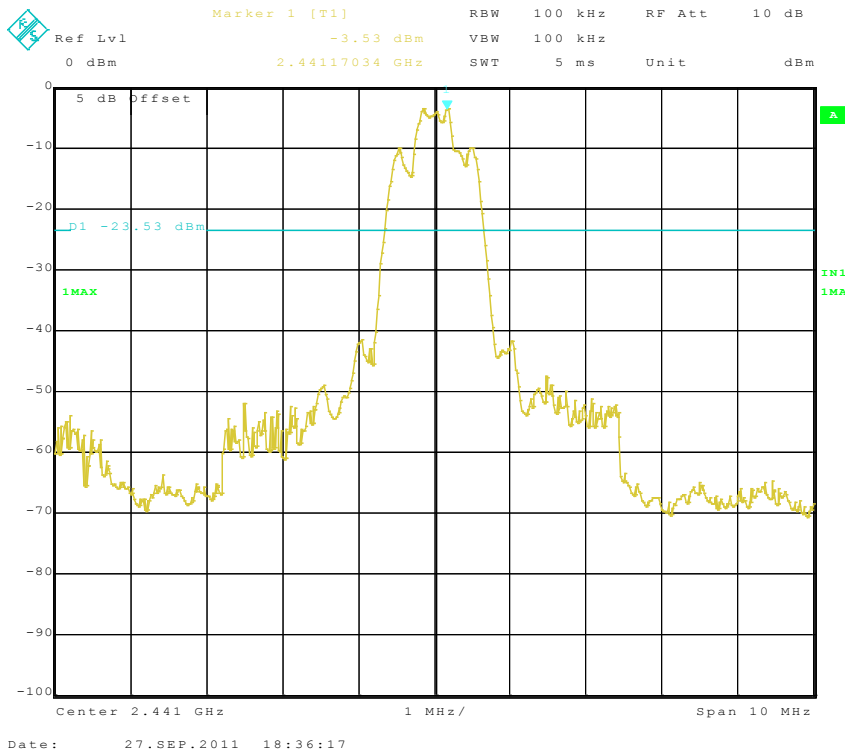

FCC Parts 15 subpart C, ANSI C63.4-2003, FCC DA 00-705
 Equipment: Sonim XP3300-A-X1

REPORT NO.: I11GC0421-FCC-BT-3

dBm Marker 3 [T1] RBW 100 kHz RF Att 10 dB
 Ref Lvl -61.23 dBm VBW 100 kHz
 0 dBm 2.57114228 GHz SWT 500 ms Unit dBm

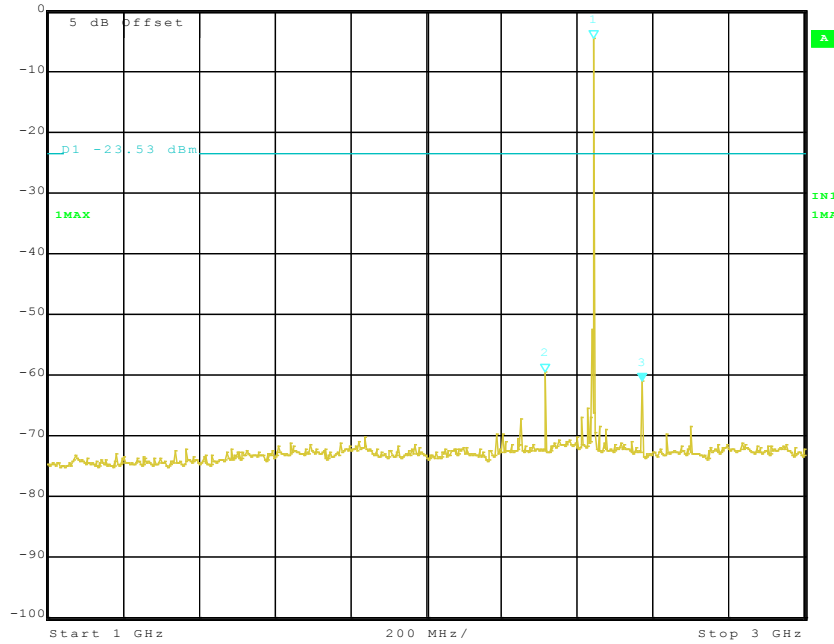

Date: 27.SEP.2011 18:38:12

dBm Marker 3 [T1] RBW 100 kHz RF Att 10 dB
 Ref Lvl -69.31 dBm VBW 100 kHz
 0 dBm 6.98396794 GHz SWT 1.75 s Unit dBm

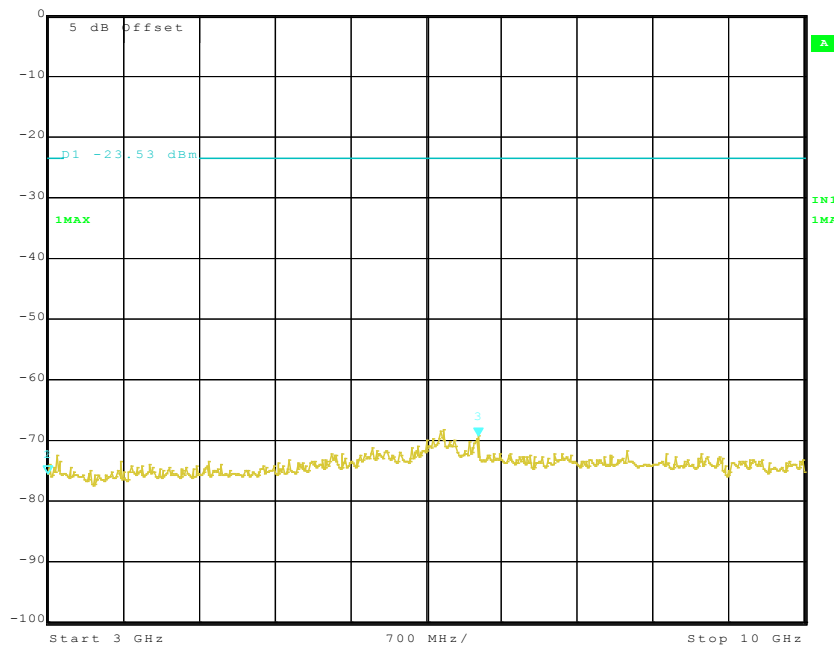

Date: 27.SEP.2011 18:38:38

FCC Parts 15 subpart C, ANSI C63.4-2003, FCC DA 00-705
 Equipment: Sonim XP3300-A-X1

REPORT NO.: I11GC0421-FCC-BT-3

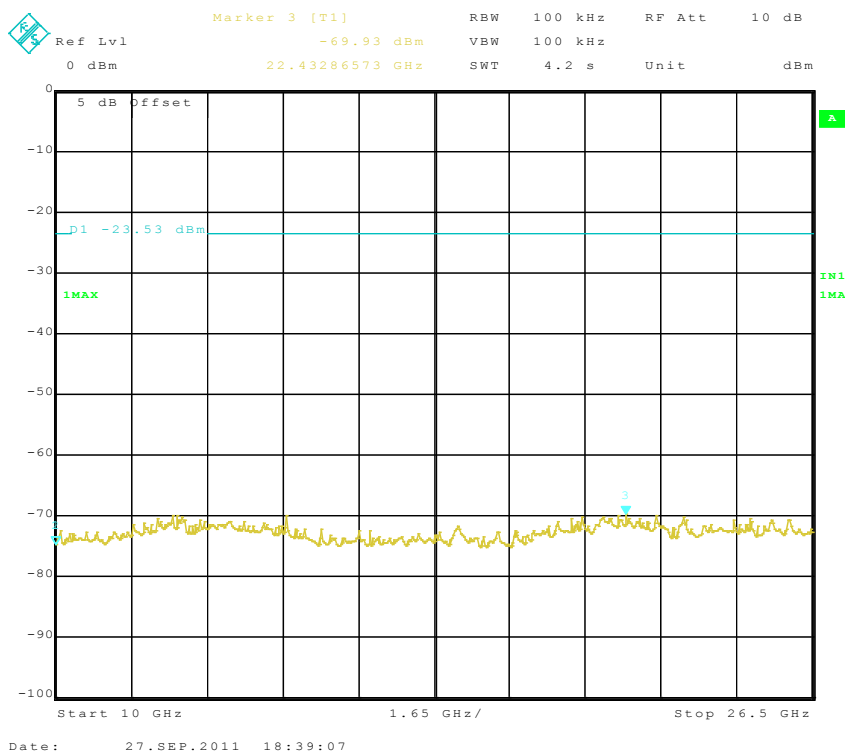

Pi/4 DQPSK Channel 78

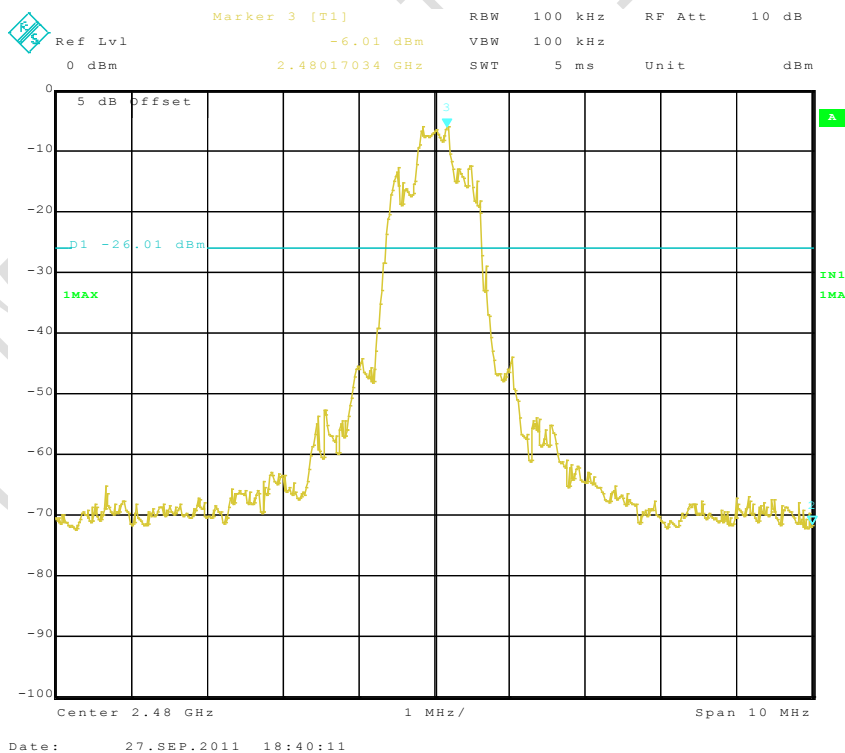

FCC Parts 15 subpart C, ANSI C63.4-2003, FCC DA 00-705
Equipment: Sonim XP3300-A-X1

REPORT NO.: I11GC0421-FCC-BT-3

Marker 1 [T1] RBW 100 kHz RF Att 10 dB
Ref Lvl -63.08 dBm VBW 100 kHz
0 dBm 873.64729459 MHz SWT 245 ms Unit dBm

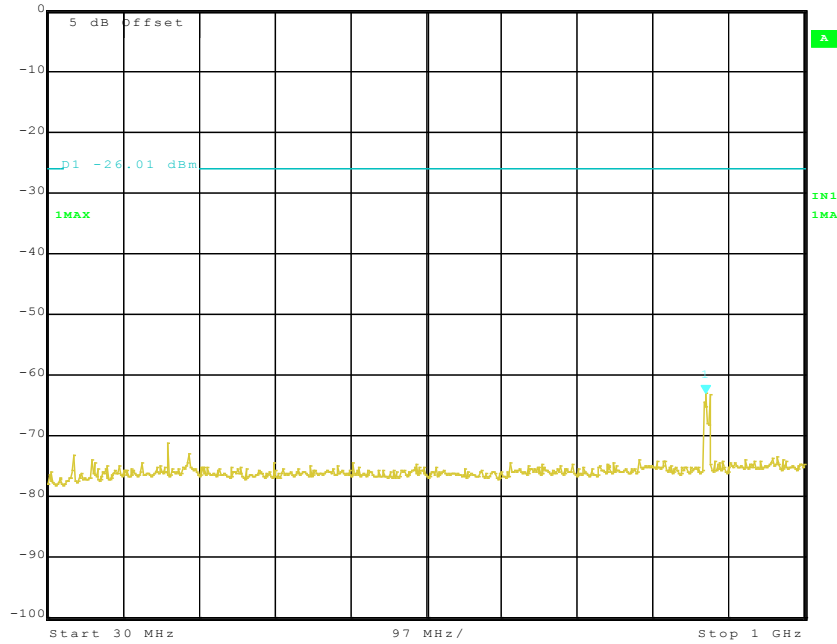

Date: 27.SEP.2011 18:40:46

Marker 3 [T1] RBW 100 kHz RF Att 10 dB
Ref Lvl -62.90 dBm VBW 100 kHz
0 dBm 2.60721443 GHz SWT 500 ms Unit dBm

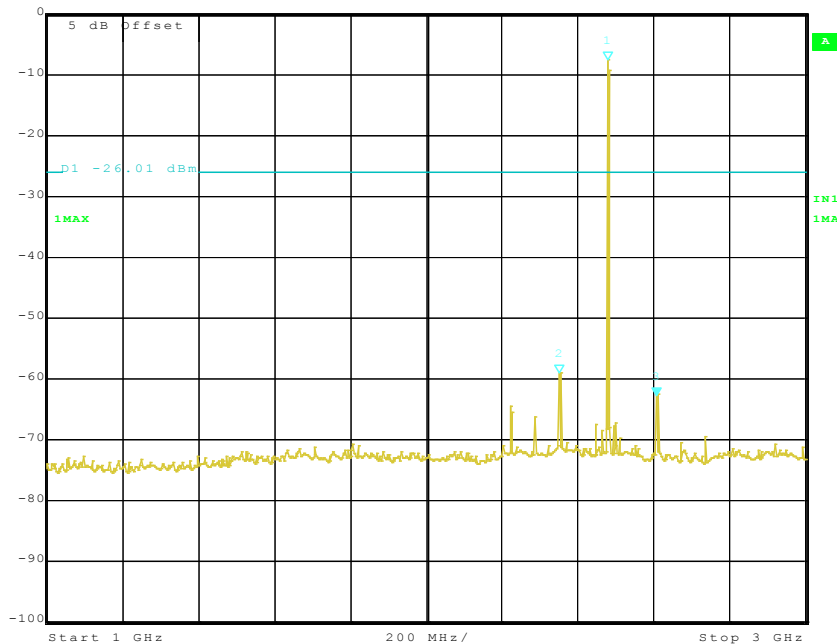

Date: 27.SEP.2011 18:41:59

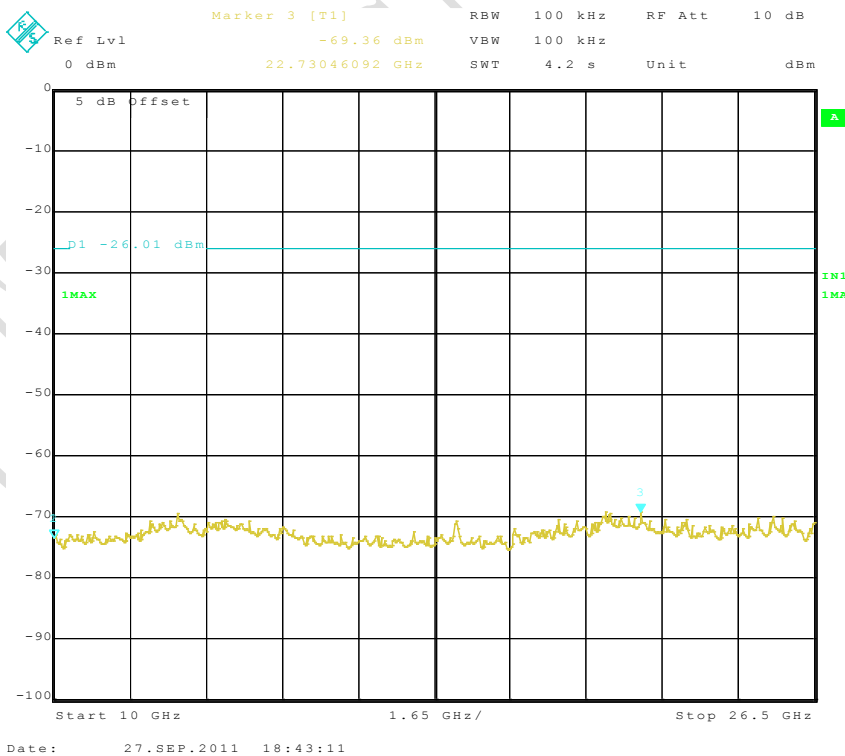
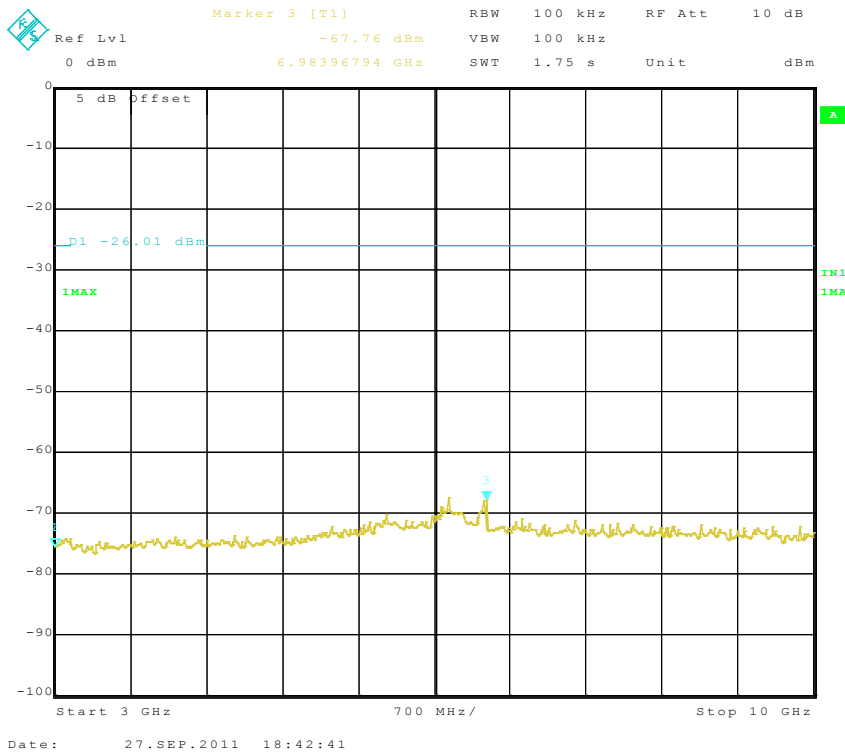

8DPSK Channel 0

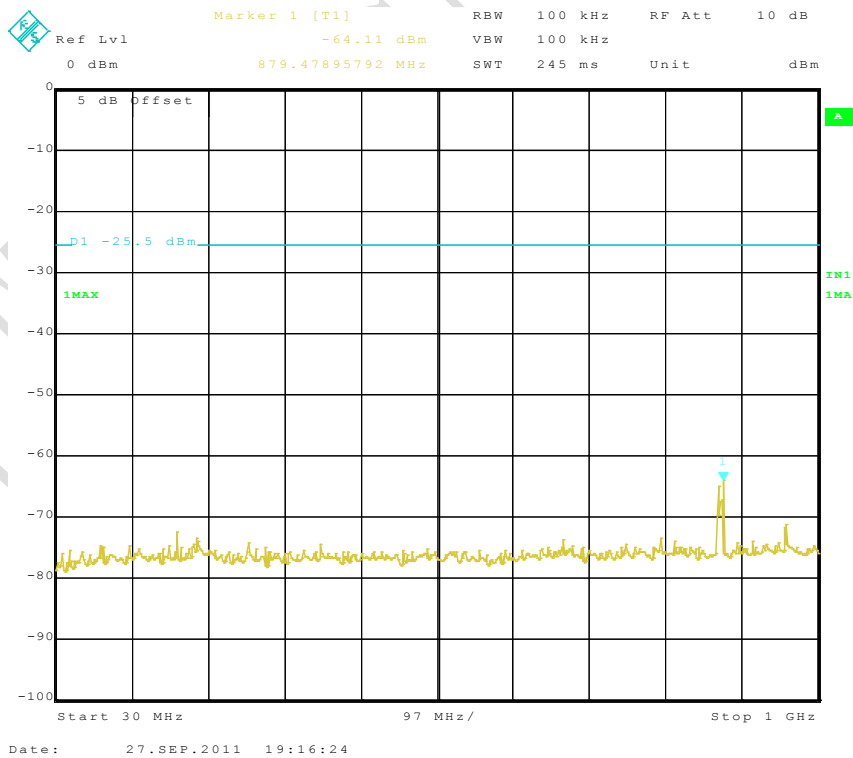
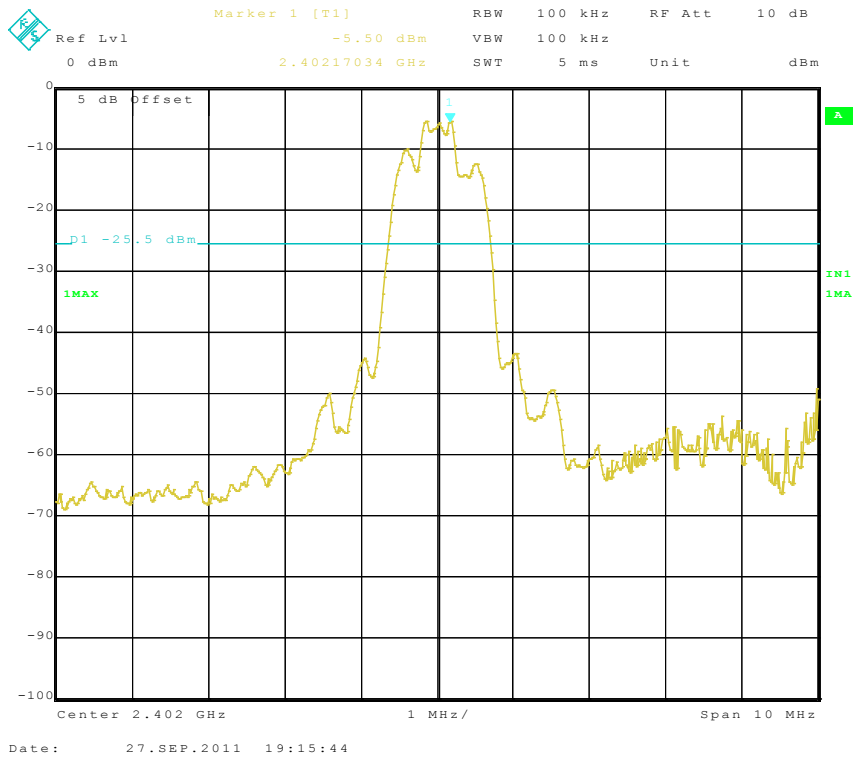

FCC Parts 15 subpart C, ANSI C63.4-2003, FCC DA 00-705
 Equipment: Sonim XP3300-A-X1

REPORT NO.: I11GC0421-FCC-BT-3

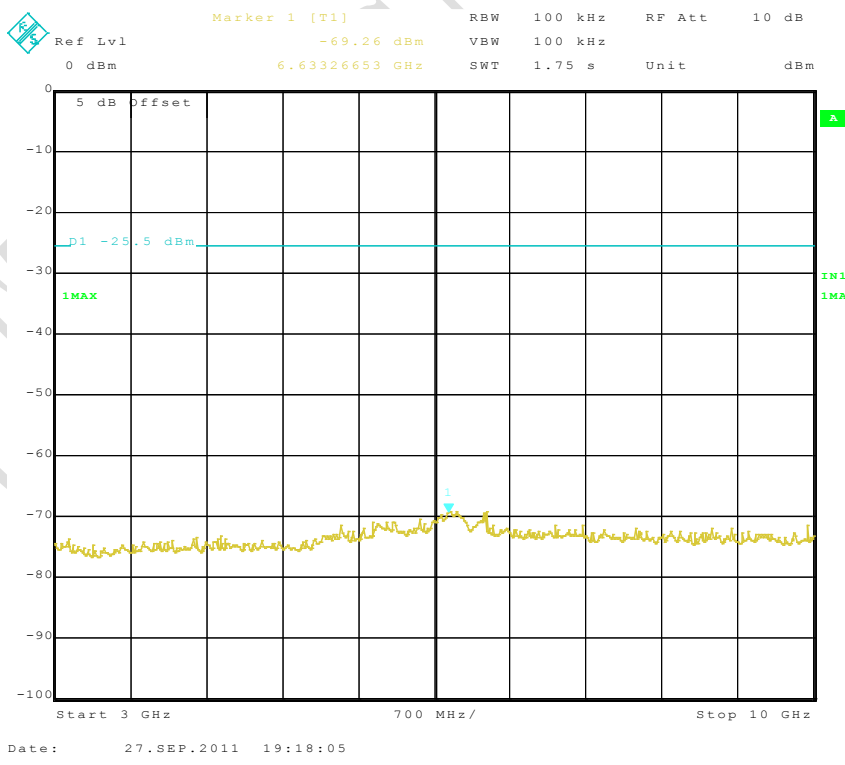
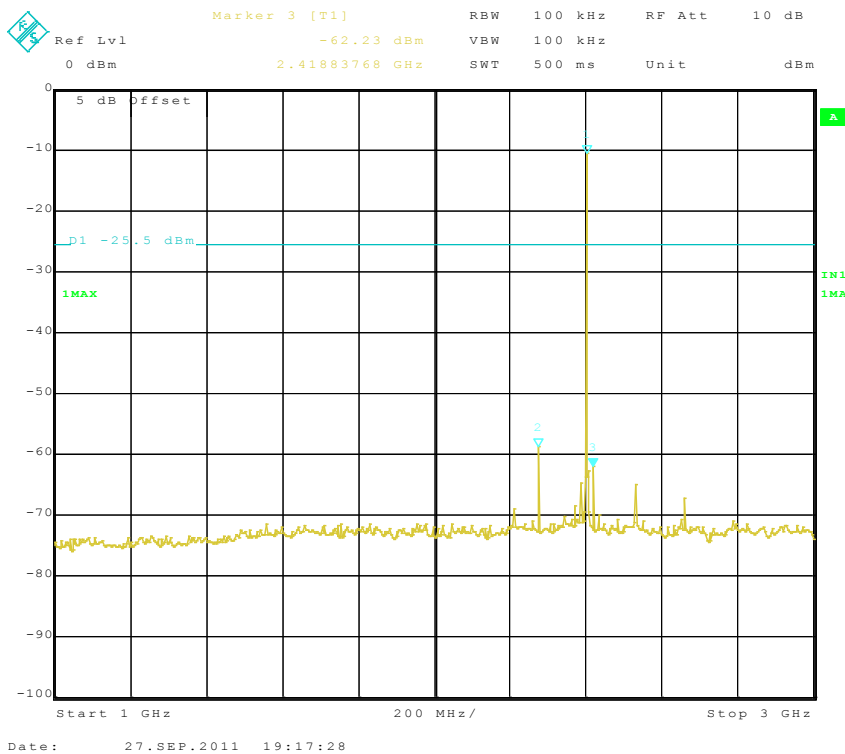

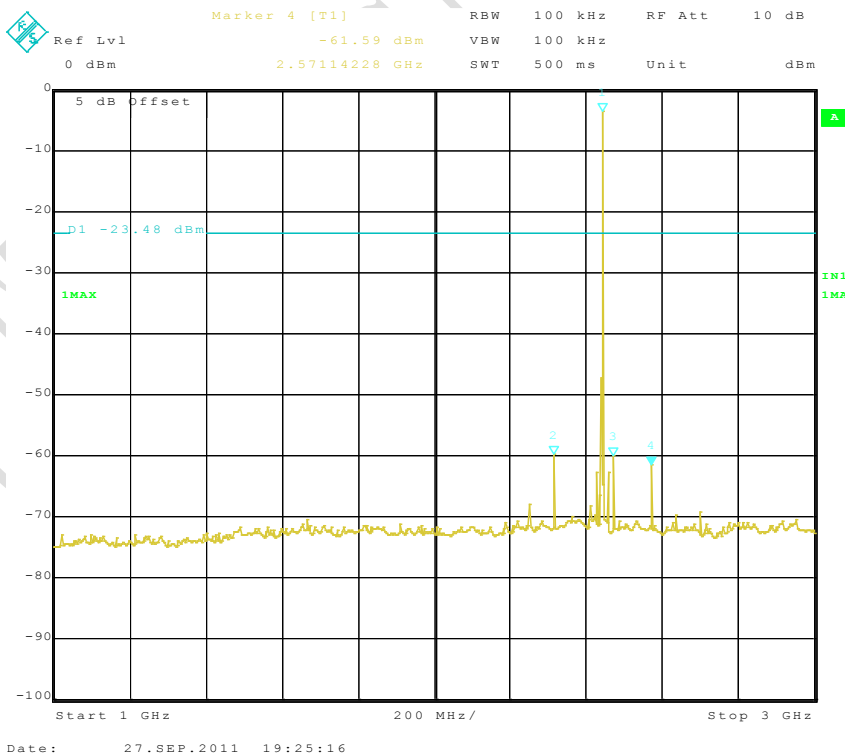
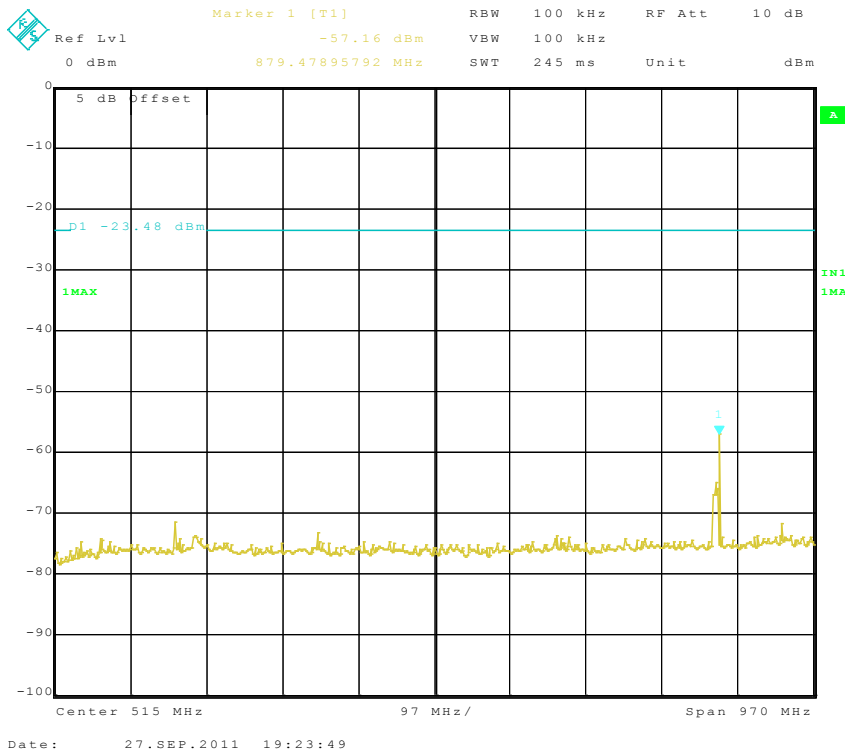

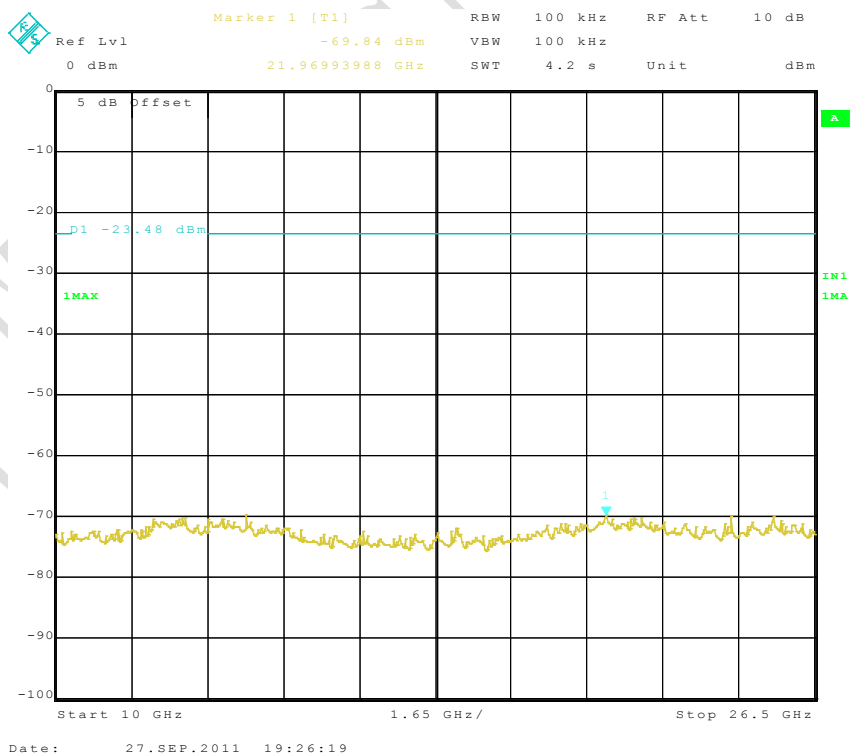
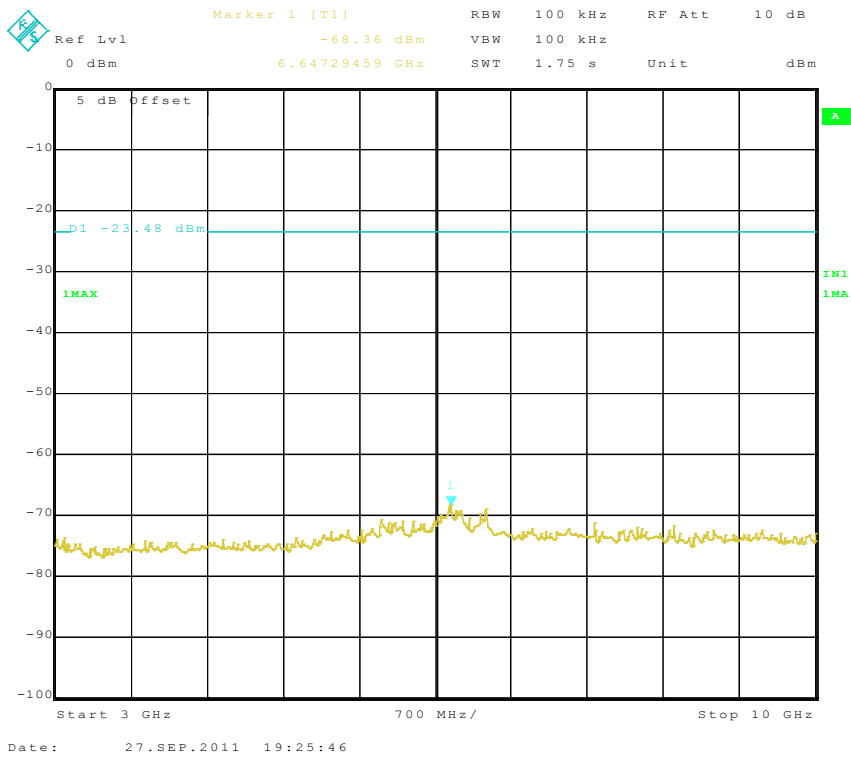

8DPSK Channel 78

FCC Parts 15 subpart C, ANSI C63.4-2003, FCC DA 00-705
Equipment: Sonim XP3300-A-X1

REPORT NO.: I11GC0421-FCC-BT-3

dBm
Marker 1 [T1]
RBW 100 kHz
RF Att 10 dB
 Ref Lvl -5.93 dBm VBW 100 kHz
 0 dBm 2.48019038 GHz SWT 5 ms Unit dBm

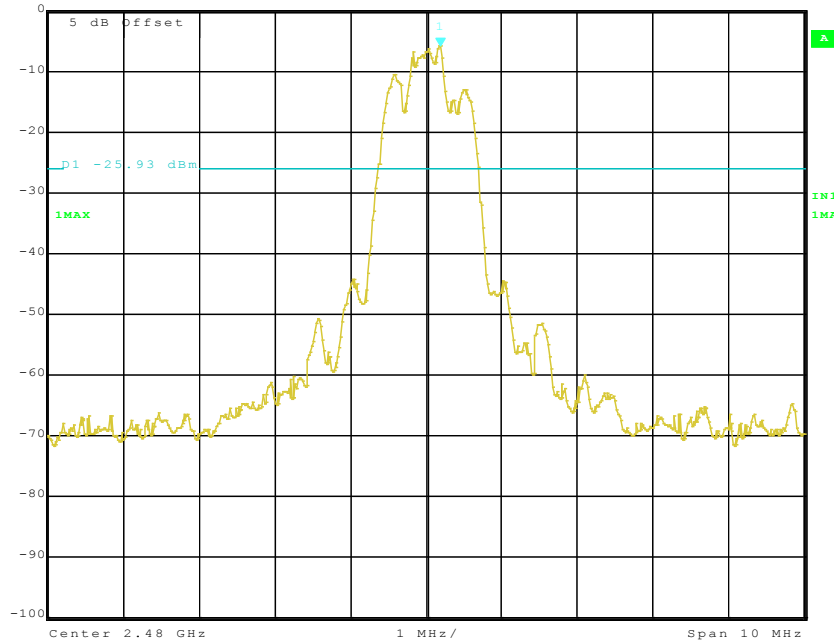

Date: 27.SEP.2011 19:27:49

dBm
Marker 1 [T1]
RBW 100 kHz
RF Att 10 dB
 Ref Lvl -64.04 dBm VBW 100 kHz
 0 dBm 873.64729459 MHz SWT 245 ms Unit dBm

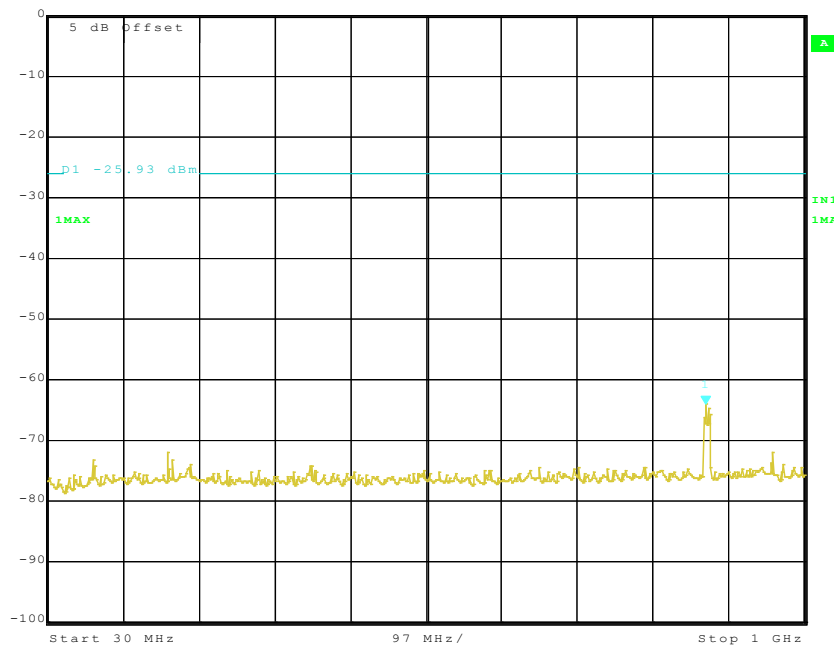

Date: 27.SEP.2011 19:28:22

FCC Parts 15 subpart C, ANSI C63.4-2003, FCC DA 00-705
 Equipment: Sonim XP3300-A-X1

REPORT NO.: I11GC0421-FCC-BT-3

RBW 100 kHz RF Att 10 dB
VBW 100 kHz
SWT 500 ms Unit dBm

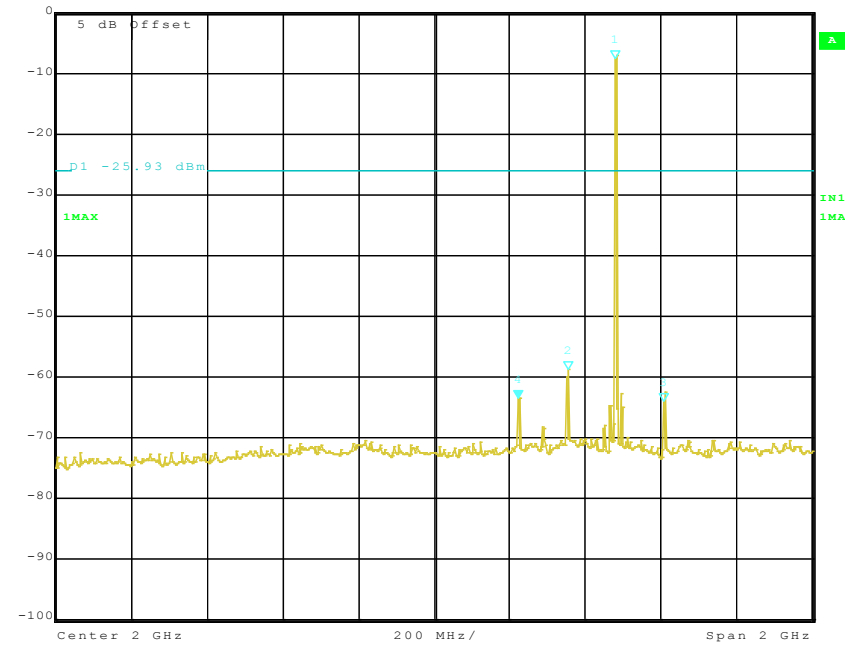

Date: 27.SEP.2011 19:30:30

RBW 100 kHz RF Att 10 dB
VBW 100 kHz
SWT 1.75 s Unit dBm

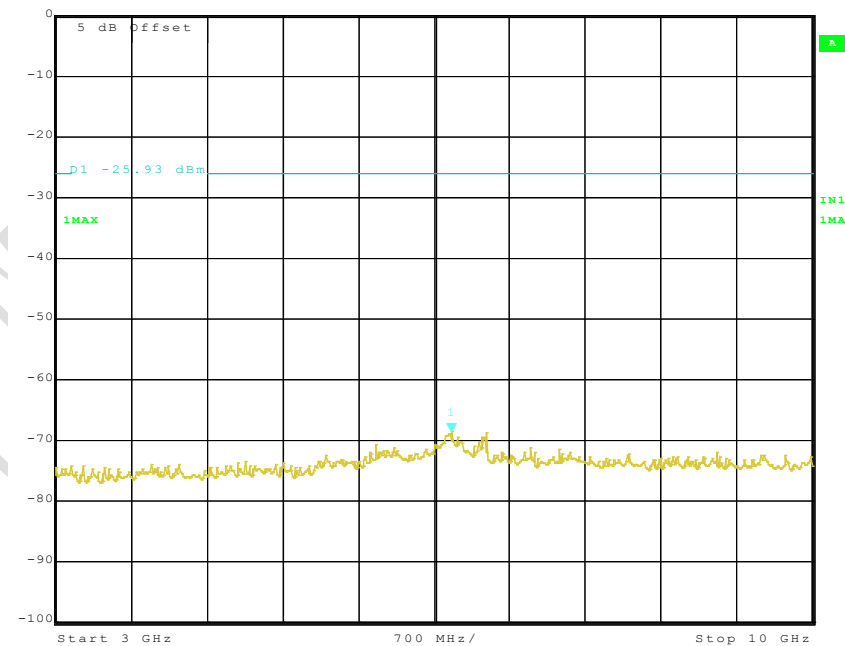

Date: 27.SEP.2011 19:30:59

FCC Parts 15 subpart C, ANSI C63.4-2003, FCC DA 00-705
Equipment: Sonim XP3300-A-X1

REPORT NO.: I11GC0421-FCC-BT-3

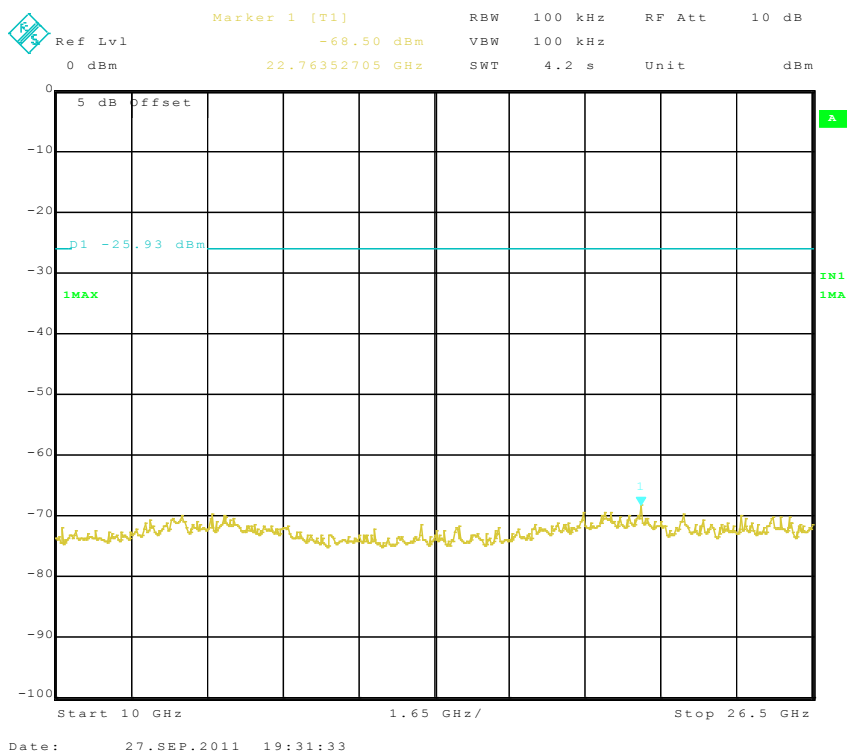

CTTL TEST

4.7 Radiated Emission Measurement

Specifications:	15.209(a) and 15.205(a)					
Date of Test	2011-09-27~28					
Test conditions:	Ambient Temperature:15°C-35°C Relative Humidity:30%-60% Air pressure: 86-106kPa					
Operation Mode	Fix channel transmit					
Test Results:	Pass					
Test equipment Used:						
Asset Number	Description	Manufacturer	Model Number	Serial Number	Cal Due	State
7805	EMI Test Receiver	R&S	ESIB26	100211	2012-01-12	Normal
713	Fully-Anechoic Chamber	ETS	11.8m×6.5m×6.3 m	--	2013-11-16	Normal
7330	BLUETOOTH TESTER	R/S	CBT	100657	2012-01-28	Normal
7330	Loop Antenna	R&S	HFH2-Z2	836553/001	2012-08-23	Normal
7330	Double-Ridged Horn Antenna	R&S	HF906	100037	2013-11-17	Normal
7330	Ultra Broad Antenna	Schwarzbeck	Vulb9160	Vulb9160-32 52	2013-11-24	Normal
7330	Horn Antenna	ETS	3160-09	1247	2013-11-17	Normal
7330	Biconical VHF-UHF test Antenna	Schwarzbeck	VUBA9117	Vulb9160-05	2013-11-24	Normal
7330	Double-Ridged Horn Antenna	R/S	HF906	100036	2013-11-17	Normal
7330	Signal Generator	R/S	SMR27	100003	2012-01-18	Normal

Limit:

1. 20dBc in any 100kHz bandwidth outside the operating frequency band. In case the emission fall within the restricted band specified on 15.205(a), then the 15.209(a) limit in the table below has to be followed

Frequency (MHz)	Field Strength (uV/m)	Measurement Distance (m)
1.705-30	30	30
30-88	100	3
88-216	150	3
216-960	200	3
Above 960	500	3

Test Setup

The EUT was placed in an anechoic chamber. The BLUETOOTH TESTER was used to set the TX channel and power level. The transmitter output is connected to Spectrum analyzer through a Bilog antenna (for frequency 30MHz~1GHz) or a horn antenna (for frequency above 1GHz).

30MHz~1GHz:

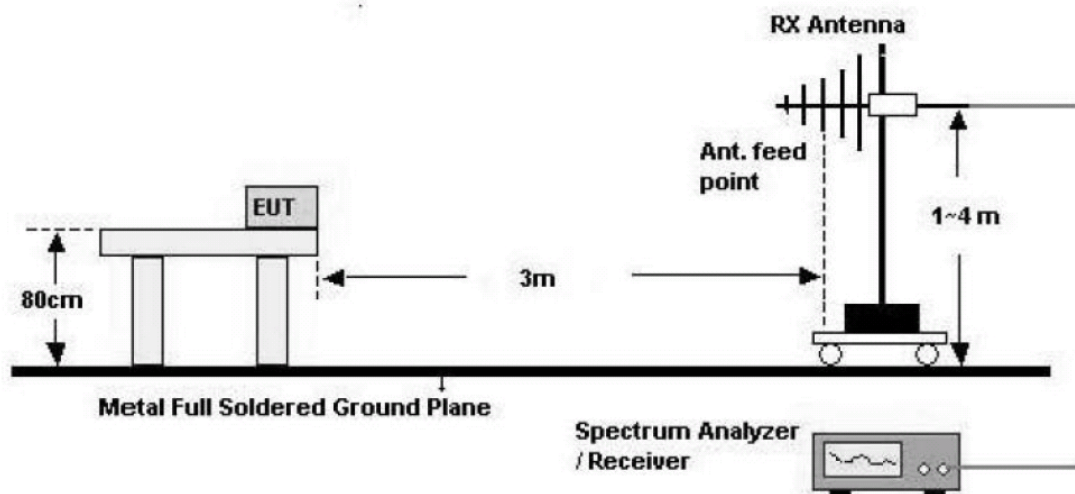

Above 1GHz:

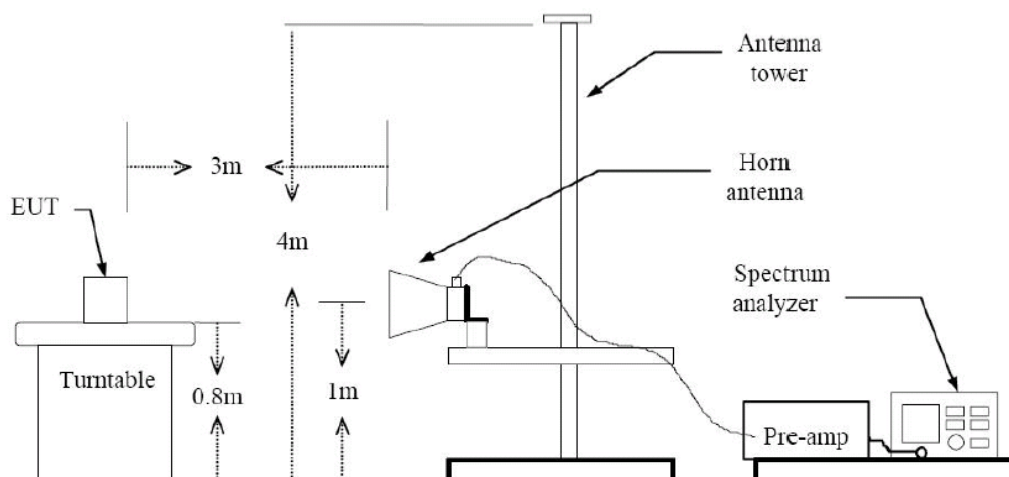

TEST PROCEDURE

1. The EUT is placed on a turntable, which is 0.8 m above ground plane.
2. The turntable shall be rotated for 360 degrees on EUT's x, y and z axis to determine the position of maximum emission level.
3. EUT is set 3 m away from the receiving antenna, which is varied from 1m to 4m to find out the highest emissions.
4. Maximum procedure was performed on the six highest emissions to ensure EUT compliance.
5. And also, each emission was to be maximized by changing the polarization of receiving antenna both horizontal and vertical.
6. Repeat above procedures until the measurements for all frequencies are complete.

The measurement is made according to Public notice FCC Public Notice DA 00-705, March 2000, and ANSI C63.4-2003.

Test Settings:

Frequency Range (MHz)	RBW/VBW	Sweep time (s)
30 – 1000	100kHz/300kHz	5
1000 – 4000	1MHz/3MHz	15
4000 – 18000	1MHz/3MHz	40
18000 – 26500	1MHz/3MHz	20

Note: Considering the GFSK modulation with packet type DH5 has the maximum transmission power, so only this mode is tested.

Test result:

Channel	Frequency Range	Results
Channel 0	30MHz – 1GHz	Pass
	1 GHz – 4GHz	Pass
	2.38GHz-2.45GHz*	Pass
	4 GHz – 18 GHz	Pass
Channel 39	30MHz – 1GHz	Pass
	1 GHz – 4GHz	Pass
	2.4GHz-2.48GHz*	Pass
	4 GHz – 18 GHz	Pass
Channel 78	30MHz – 1GHz	Pass
	1 GHz – 4GHz	Pass
	2.45GHz-2.5GHz*	Pass
	4 GHz – 18 GHz	Pass
All channels	18GHz-26.5GHz	Pass

Note*: these tests demonstrate the radiated band-edge test results

Channel 0:

Frequency MHz	SG Reading dBuV	Cable loss dB	Antenna Gain dB	Total dBuV/m	Limit dBuV/m	Margin dB	Ant. Pol. H/V
37.640	67.039	0.4	-38.14	28.499	40.0(QP)	11.501	H
267.760	22.461	0.5	0.93	22.891	46.0(QP)	23.109	H
3633.000	41.80	4.07	9.87	47.6	54.0(AV)	6.4	V

3800.500	41.20	2.94	9.84	48.1	54.0(AV)	5.9	V
3874.500	42.10	3.12	9.82	48.8	54.0(AV)	5.2	V
3911.000	42.40	3.22	9.82	49.0	54.0(AV)	5.0	V

Channel 39:

Frequency MHz	SG Reading dBuV	Cable loss dB	Antenna Gain dB	Total dBuV/m	Limit dBuV/m	Margin dB	Ant. Pol. H/V
81.200	46.031	0.4	-21.42	24.211	77.58(QP)	53.369	H
267.760	21.843	0.5	0.93	22.273	46.0(QP)	23.727	H
3336.500	43.1	4.70	9.90	48.3	54.0(AV)	5.7	V
3357.000	42.4	4.70	9.90	47.6	54.0(AV)	6.4	V
3731.500	42.2	3.25	9.85	48.8	54.0(AV)	5.2	V
3811.500	42.3	2.94	9.84	49.2	54.0(AV)	4.8	V

Channel 78:

Frequency MHz	SG Reading dBuV	Cable loss dB	Antenna Gain dB	Total dBuV/m	Limit dBuV/m	Margin dB	Ant. Pol. H/V
37.920	67.025	0.4	-38.10	28.525	40.0	11.475	H
267.720	21.471	0.5	0.93	21.901	46.0	24.099	H
3722.000	43.2	3.36	9.86	49.7	54.0	4.3	V
3772.500	41.7	3.05	9.85	48.5	54.0	5.5	V
3859.000	41.5	3.13	9.83	48.2	54.0	5.8	V
3868.500	41.7	3.13	9.83	48.4	54.0	5.6	V

Notes:

1. Radiated emissions were measured with an instrument using Quasi-peak detector mode in frequency range from 30 MHz to 1000MHz, and with peak detector mode in frequency range from 1GHz – 26.5 GHz.
- 2 Total dBuV/m = Reading dBuV/m – Cable Loss dB + Antenna Gain dB.

Test Plots:

FCC Part15C 1G

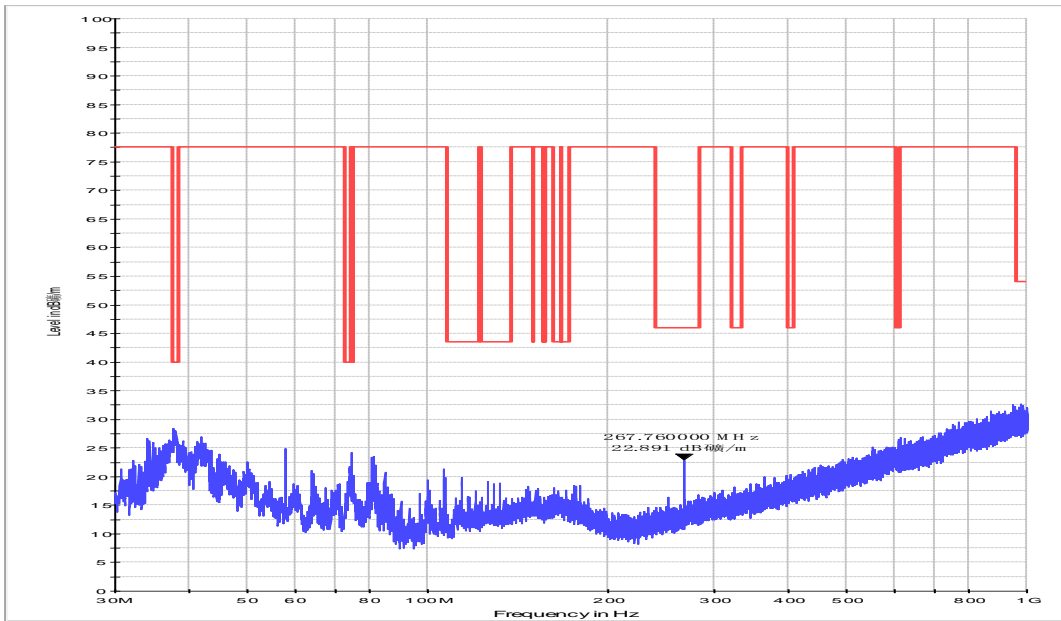

GFSK DH5 Channel 0 30MHz~1GHz

FCC Part15C 1-4G

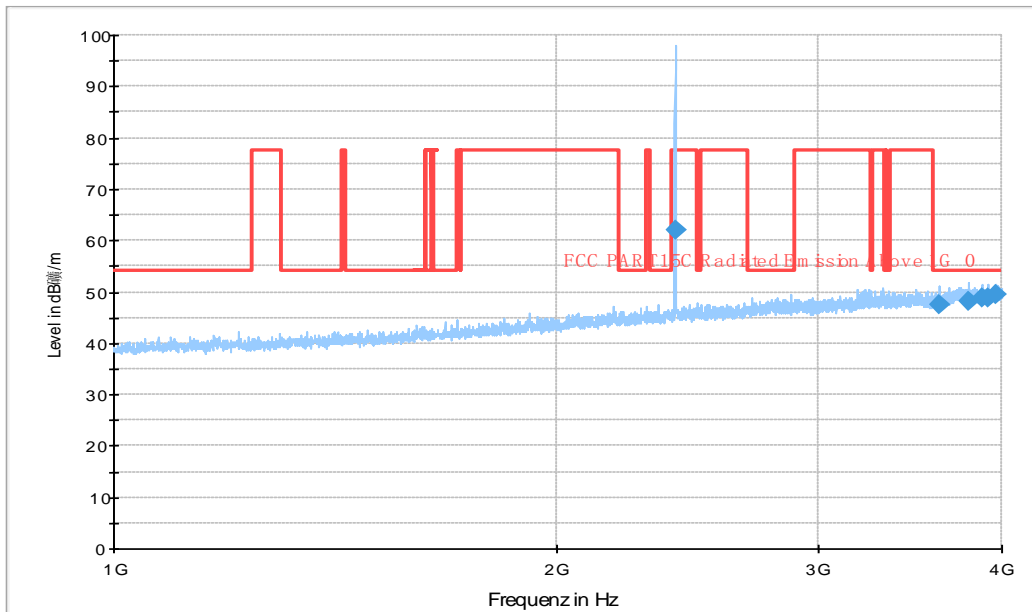

GFSK DH5 Channel 0 1~4GHz

FCC Part15C 2.38-2.45G

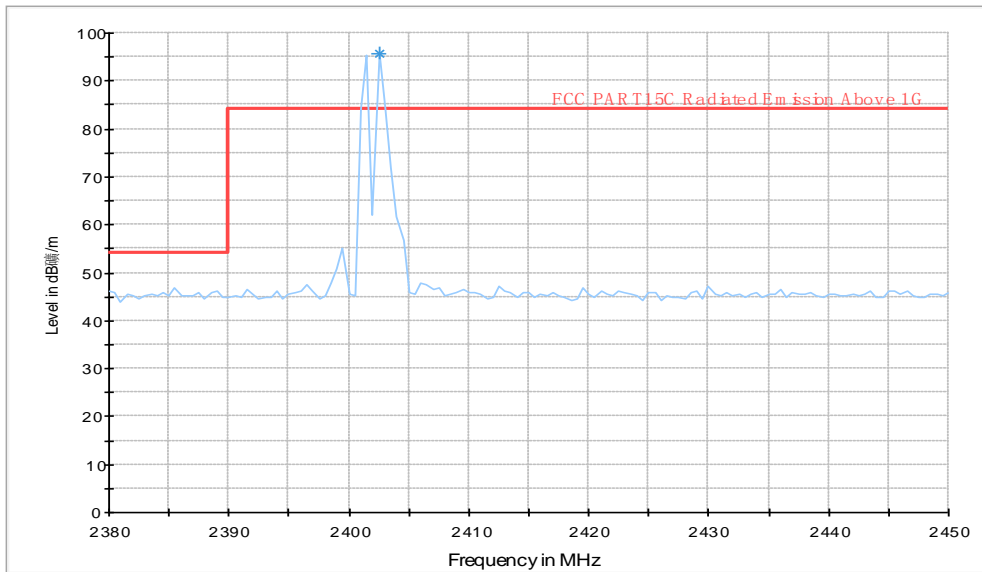

GFSK DH5 Channel 0 2.38~2.45GHz

Copy of FCC Part15C 26G

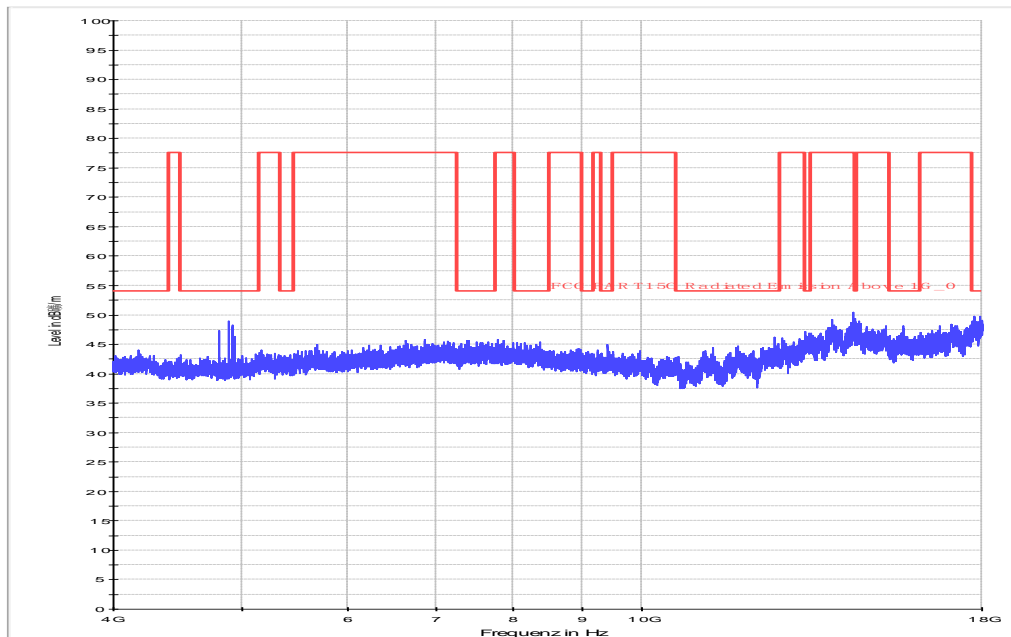

GFSK DH5 Channel 0 4~18GHz

FCC Part15C 1G

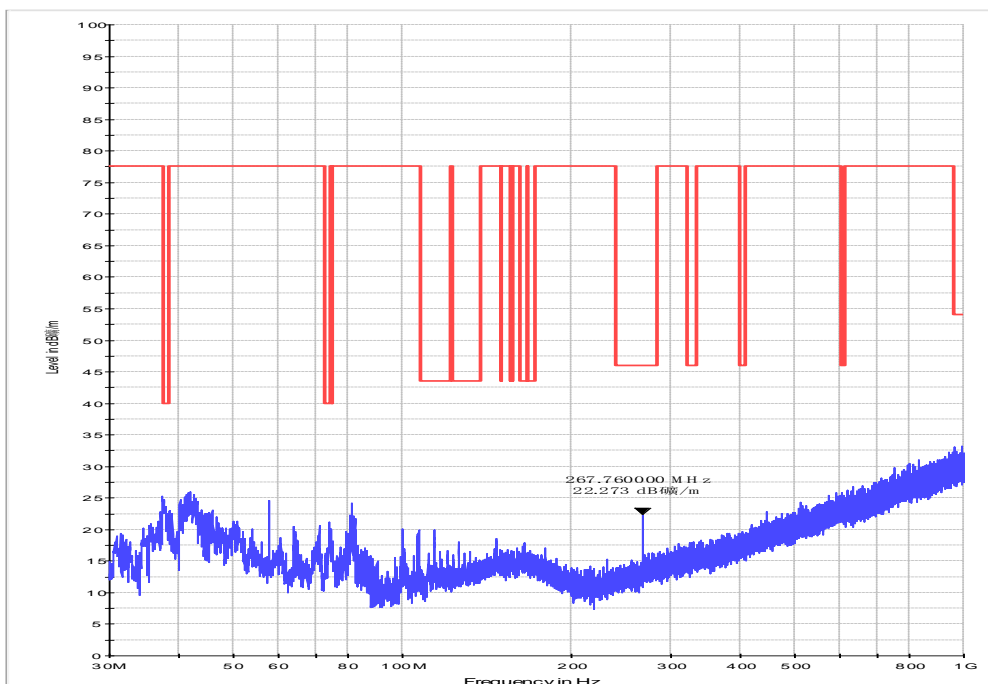

GFSK DH5 Channel 39 30MHz~1GHz

FCC Part15C 1-4G

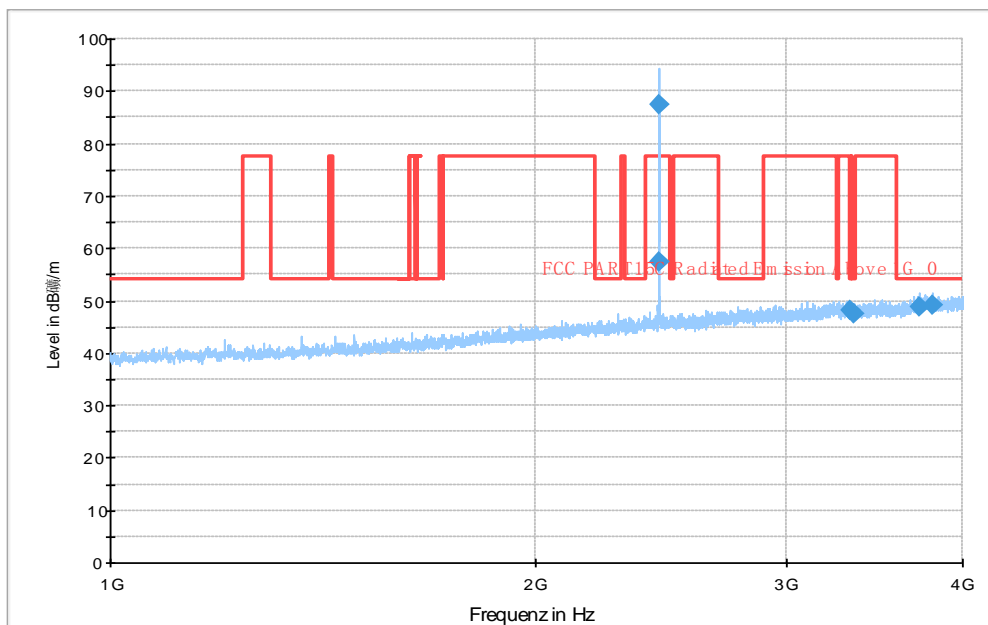

GFSK DH5 Channel 39 1~4GHz

FCC Part15C 2.4~2.48G

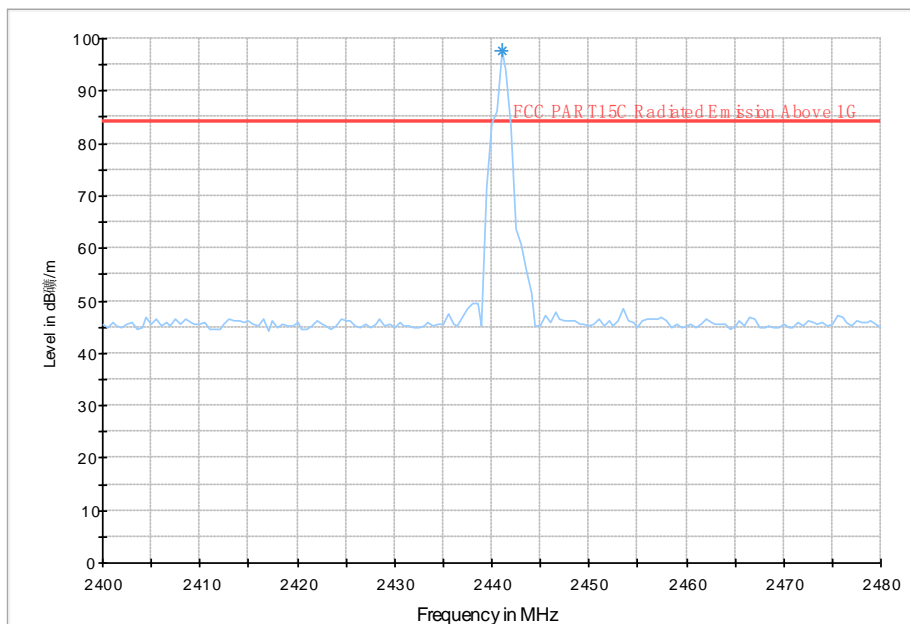

GFSK DH5 Channel 39 2.4~2.48GHz

Copy of FCC Part15C 26G

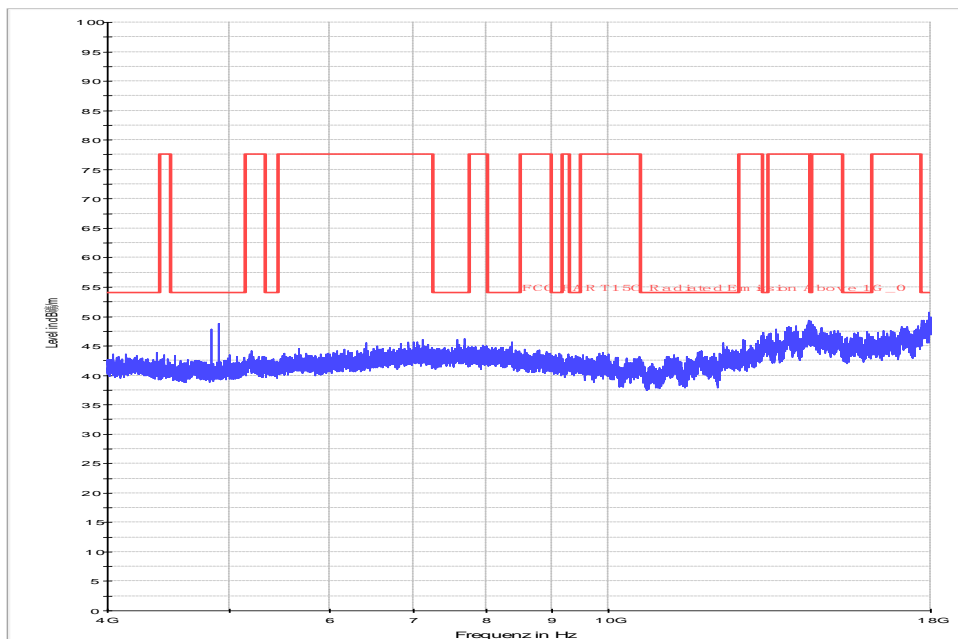

GFSK DH5 Channel 39 4~18GHz

FCC Part15C 1G

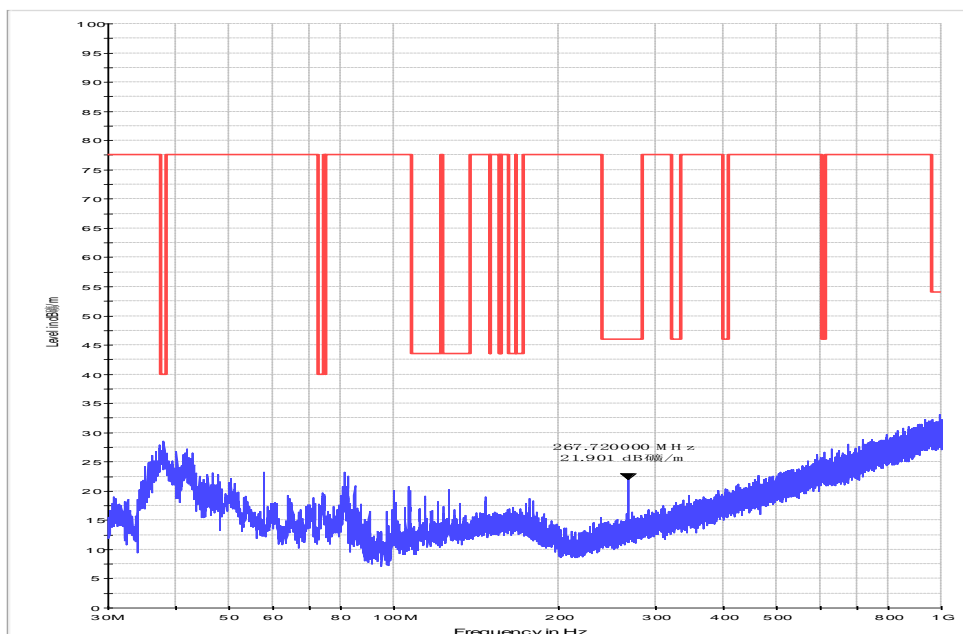

GFSK DH5 Channel 78 30MHz~1GHz

FCC Part15C 1-4G

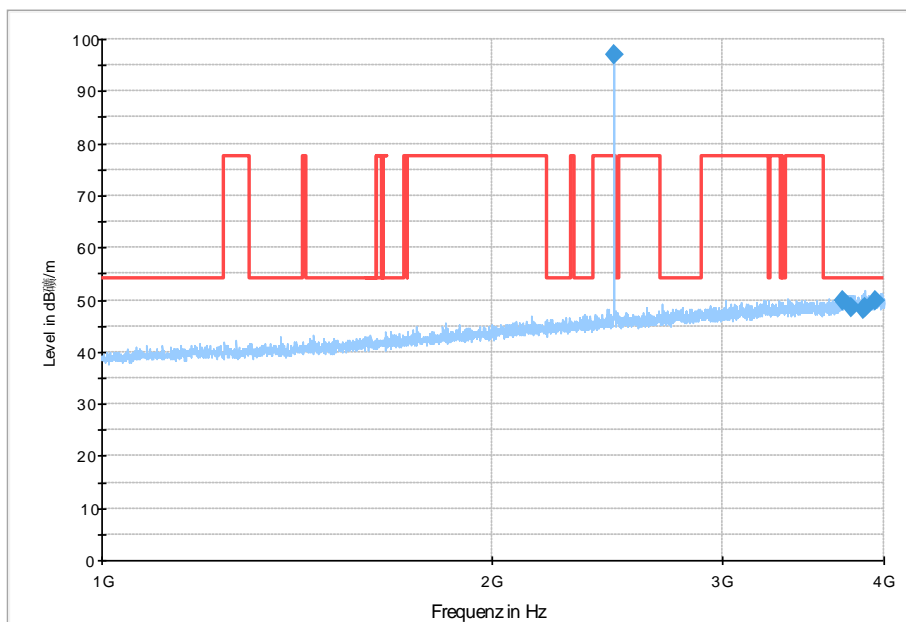

GFSK DH5 Channel 78 1~4GHz

FCC Part15C 2.45-2.5G

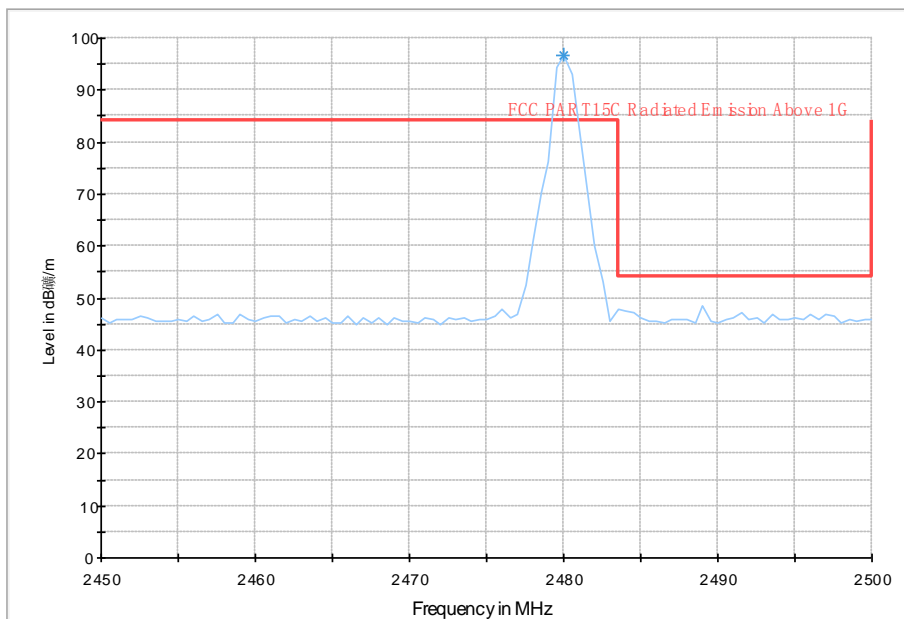

GFSK DH5 Channel 39 2.45~2.5GHz

Copy of FCC Part15C 26G

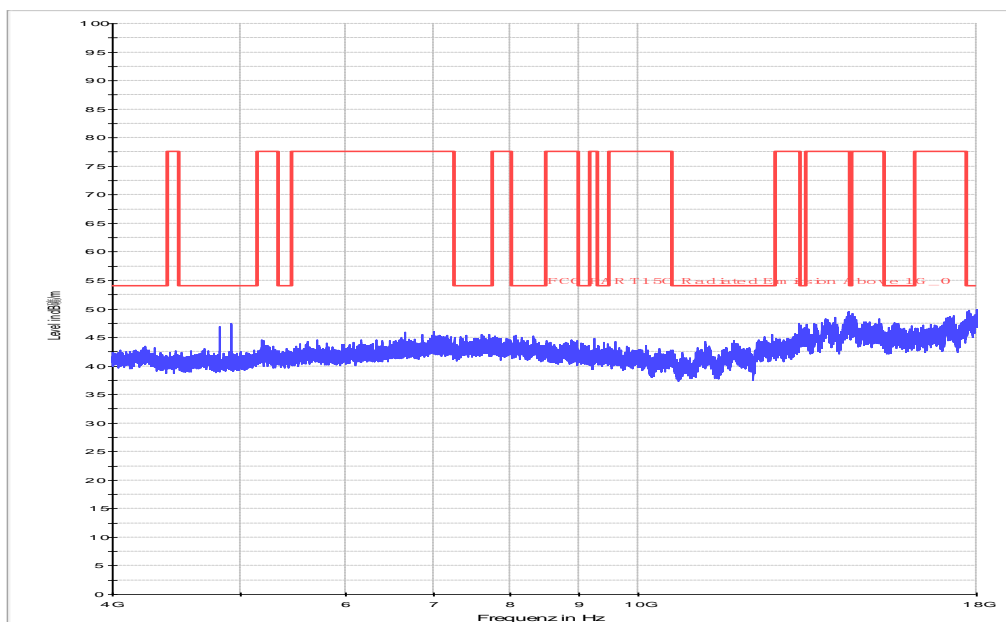

GFSK DH5 Channel 39 4~18GHz

Copy (2) of FCC Part15C 18-26G

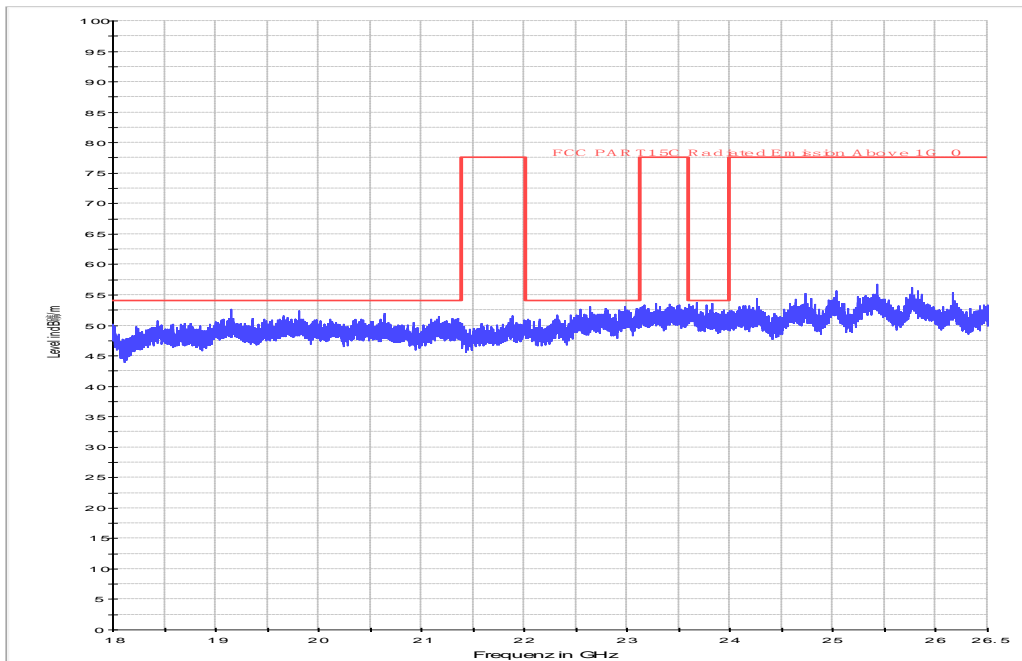

GFSK DH5 all channels

CTTL TEST

4.8 Power line Conducted Emissions

Specifications:	ANSI C63.4 voltage mains test					
Date of Test	2011-06-30					
Test conditions:	Ambient Temperature:15°C-35°C Relative Humidity:30%-60% Air pressure: 86-106kPa					
Operation Mode	Hopping					
Test Results:	Pass					
Test equipment Used:						
Asset Number	Description	Manufacturer	Model Number	Serial Number	Cal Due	State
7805	EMI Test Receiver	R/S	ESIB26	100211	2012-01-12	Normal
7330	Artificial Mains Network	R/S	ESH2-Z5	837480/002	2013-01-08	Normal
714	Shielding Room	ETS	--	19003	2013-11-16	Normal
7330	BLUETOOTH TESTER	R/S	CBT	100657	2012-01-28	Normal

LIMIT

For an intentional radiator which is designed to be connected to the public utility (AC) power line, the radio frequency voltage that is conducted back onto the AC power line on any frequency or frequencies within the band 150 kHz to 30 MHz shall not exceed 250 microvolt (The limit decreases linearly with the logarithm of the frequency in the range 0.15 MHz to 0.50 MHz). The limits at specific frequency range are listed as follows:

Limits of the conducted disturbance at the AC mains ports:

Frequency range	Limit(Quasi-peak)	Limit(Average)
0.15 MHz to 0.5 MHz	66 dBµV – 56 dBµV	56 dBµV – 46 dBµV
>0.5 MHz to 5MHz	56 dBµV	46 dBµV
>5 MHz to 30 MHz	60 dBµV	50 dBµV

NOTE: The limit decreases linearly with the logarithm of the frequency in the range 0.15 MHz to 0.50 MHz.

Compliance with this provision shall be based on the measurement of the radio frequency voltage between each power line (LINE and NEUTRAL) and ground at the power terminals.

Test Setup

The EUT was placed in a shielding room. The BLUETOOTH TESTER was used to set the TX channel and power level. The ac adapter output is connected to Receiver through an AMN (Artificial Mains Network).

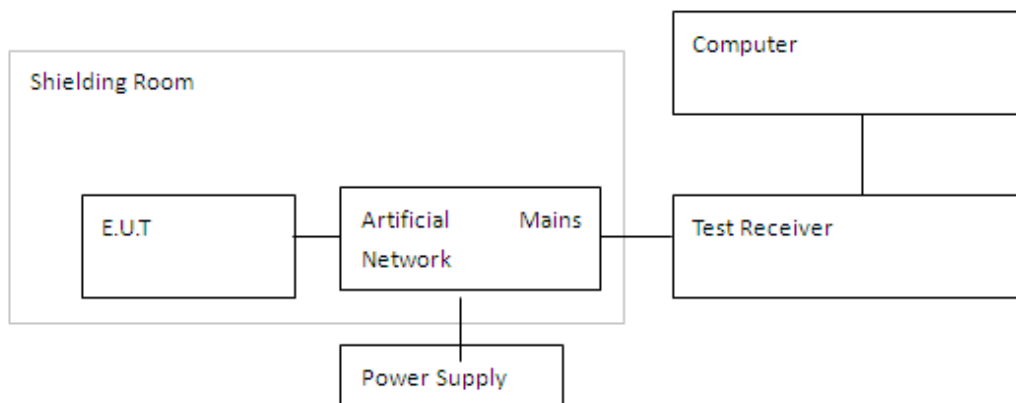

TEST PROCEDURE

1. The EUT is placed on a wooden table 80 cm above the reference ground plane.
2. The EUT is connected via LISN to a test power supply.
3. The measurement results are obtained as described below:
4. Detectors – Quasi Peak and Average Detector.

The measurement is made according to Public notice FCC Public Notice DA 00-705, March 2000, and ANSI C63.4-2003.

Test Result:

Line L					
Detector (QP/AV)	Frequency (MHz)	Level (dBµV)	Limit (dBµV)	Line	PE
QP	0.384000	52.8	58	L	FLO
QP	0.636000	49.5	56	L	FLO
QP	1.630500	49.0	56	L	FLO
QP	1.738500	49.3	56	L	FLO
QP	2.647500	48.2	56	L	FLO
QP	2.661000	48.9	56	L	FLO

Line N					
Detector (QP/AV)	Frequency (MHz)	Level (dBµV)	Limit (dBµV)	Line	PE
QP	0.393000	53.6	58	N	FLO
QP	0.762000	49.5	56	N	FLO
QP	1.644000	49.4	56	N	FLO
QP	1.698000	49.8	56	N	FLO
QP	1.729500	49.4	56	N	FLO
QP	2.184000	49.1	56	N	FLO

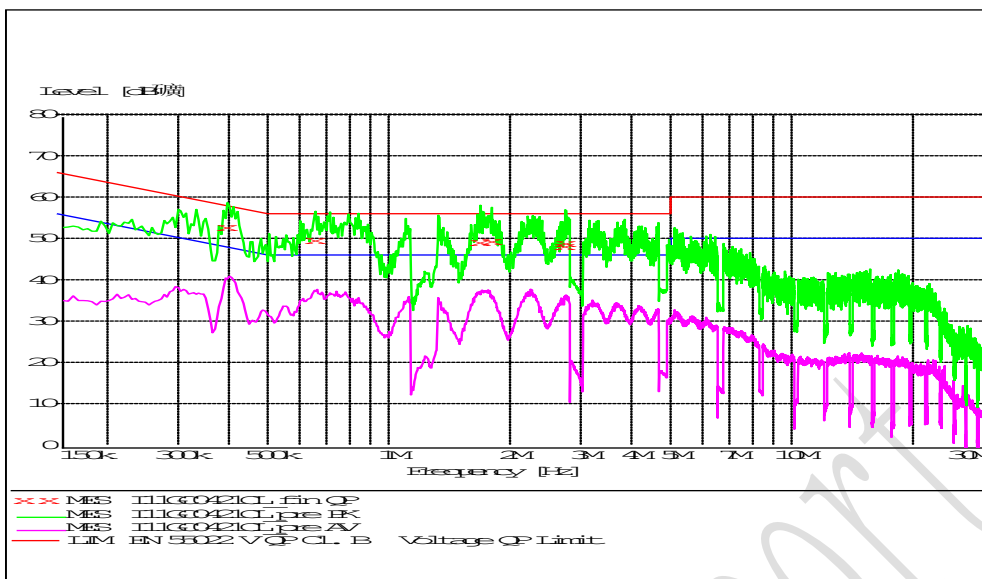

Line L

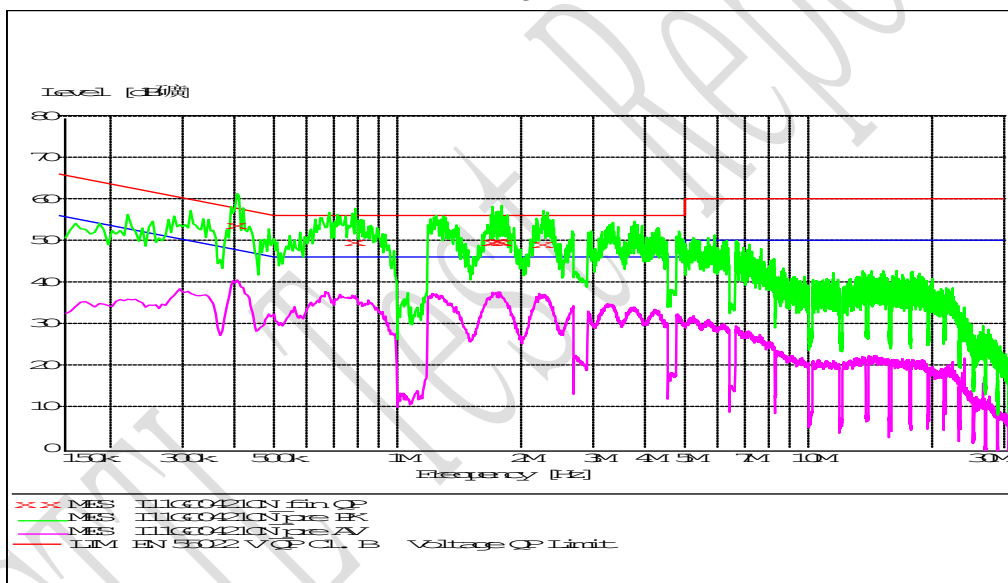

Line N

Annex A External Photos

Confidential

Confidential
TTL Test Report

TTL Test Report

Annex B Internal Photos

Confidential

Confidential
TTL Test Report

ANNEX C Deviations from Prescribed Test Methods

No deviation from Prescribed Test Methods.

————— **The End of this Report** —————

CTTL Test Report