



Test Report No.: RF160524W004-6



FCC TEST REPORT (WIFI 5G)

Product: LTE phone

Model No.: XP5700

FCC ID: WYPL23V013AA

Applicant: Sonim Technologies, Inc.

Address: 1825 S. Grant St., Suite 200., San Mateo, CA, 94402

Manufacturer: Sonim Technologies (Shenzhen) Limited

Address: 2nd Floor, No. 2 Building Phase B, Daqian Industrial park,
Longchang Road, 67 District, Baoan, Shenzhen, P. R. China

Prepared by: Bureau Veritas Shenzhen Co., Ltd. Dongguan Branch

Lab Location: No. 34, Chenwulu Section, Guantai Rd., Houjie Town,
Dongguan City, Guangdong 523942, China

TEL: +86 769 8593 5656

FAX: +86 769 8593 1080

E-MAIL: customerservice.dg@cn.bureauveritas.com

Report No.: RF160524W004-6

Received Date: May 24, 2016

Test Date: May 25, 2016 ~ Jun. 20, 2016

Issued Date: Jun. 22, 2016

This report should not be used by the client to claim product certification, approval, or endorsement by A2LA or any government agencies.

Any copying or replication of this report to or for any other person or entity, or use of our name or trademark, is permitted only with our prior written permission. This report sets forth our findings solely with respect to the test samples identified herein. The results set forth in this report are not indicative or representative of the quality or characteristics of the lot from which a test sample was taken or any similar or identical product unless specifically and expressly noted. Our report includes all of the tests requested by you and the results thereof based upon the information that you provided to us. You have 60 days from date of issuance of this report to notify us of any material error or omission caused by our negligence, provided, however, that such notice shall be in writing and shall specifically address the issue you wish to raise. A failure to raise such issue within the prescribed time shall constitute your unqualified acceptance of the completeness of this report, the tests conducted and the correctness of the report contents. Unless specific mention, the uncertainty of measurement has been explicitly taken into account to declare the compliance or non-compliance to the specification.



TABLE OF CONTENTS

RELEASE CONTROL RECORD 4

1 CERTIFICATION 5

2 SUMMARY OF TEST RESULTS..... 6

2.1 MEASUREMENT UNCERTAINTY 6

3 GENERAL INFORMATION 7

3.1 GENERAL DESCRIPTION OF EUT 7

3.2 DESCRIPTION OF TEST MODES 9

3.2.1 TEST MODE APPLICABILITY AND TESTED CHANNEL DETAIL.....11

3.3 DUTY CYCLE OF TEST SIGNAL 14

3.4 DESCRIPTION OF SUPPORT UNITS 15

3.4.1 CONFIGURATION OF SYSTEM UNDER TEST 17

3.5 GENERAL DESCRIPTION OF APPLIED STANDARDS 17

4 TEST TYPES AND RESULTS..... 18

4.1 RADIATED EMISSION AND BANDEDGE MEASUREMENT 18

4.1.1 LIMITS OF RADIATED EMISSION AND BANDEDGE MEASUREMENT..... 18

4.1.2 LIMITS OF UNWANTED EMISSION OUT OF THE RESTRICTED BANDS 18

4.1.3 TEST INSTRUMENTS..... 19

4.1.4 TEST PROCEDURES 20

4.1.5 DEVIATION FROM TEST STANDARD 20

4.1.6 TEST SETUP 21

4.1.7 EUT OPERATING CONDITION 22

4.1.8 TEST RESULTS 23

4.2 CONDUCTED EMISSION MEASUREMENT 66

4.2.1 LIMITS OF CONDUCTED EMISSION MEASUREMENT 66

4.2.2 TEST INSTRUMENTS..... 66

4.2.3 TEST PROCEDURES 66

4.2.4 DEVIATION FROM TEST STANDARD 67

4.2.5 TEST SETUP 67

4.2.6 EUT OPERATING CONDITIONS 67

4.2.7 TEST RESULTS 68



4.3	MAXIMUM CONDUCTED OUTPUT POWER MEASUREMENT	72
4.3.1	LIMITS OF MAXIMUM CONDUCTED OUTPUT POWER MEASUREMENT	72
4.3.2	TEST SETUP	72
4.3.3	TEST INSTRUMENTS.....	73
4.3.4	TEST PROCEDURE.....	73
4.3.5	DEVIATION FROM TEST STANDARD	74
4.3.6	EUT OPERATING CONDITIONS	74
4.3.7	TEST RESULTS	75
4.4	PEAK POWER SPECTRAL DENSITY MEASUREMENT	88
4.4.1	LIMITS OF PEAK POWER SPECTRAL DENSITY MEASUREMENT	88
4.4.2	TEST SETUP	88
4.4.3	TEST INSTRUMENTS.....	88
4.4.4	TEST PROCEDURES	88
4.4.5	DEVIATION FROM TEST STANDARD	89
4.4.6	EUT OPERATING CONDITIONS	89
4.4.7	TEST RESULTS	89
4.5	FREQUENCY STABILITY	92
4.5.1	LIMITS OF FREQUENCY STABILITY MEASUREMENT	96
4.5.2	TEST SETUP	96
4.5.3	TEST INSTRUMENTS.....	96
4.5.4	TEST PROCEDURE.....	97
4.5.5	DEVIATION FROM TEST STANDARD	97
4.5.6	EUT OPERATING CONDITION	97
4.5.7	TEST RESULTS	98
5	PHOTOGRAPHS OF THE TEST CONFIGURATION	100
6	APPENDIX A – MODIFICATIONS RECORDERS FOR ENGINEERING CHANGES TO THE EUT BY THE LAB	101



BUREAU
VERITAS

Test Report No.: RF160524W004-6

RELEASE CONTROL RECORD

ISSUE NO.	REASON FOR CHANGE	DATE ISSUED
RF160524W004-6	Original release	Jun. 22, 2016



1 CERTIFICATION

PRODUCT: LTE phone
BRAND NAME: Sonim
MODEL NO.: XP5700
APPLICANT: Sonim Technologies, Inc.
TESTED: May 25, 2016 ~ Jun. 20, 2016
TEST SAMPLE: Identical Prototype
STANDARDS: **FCC Part 15, Subpart E (15.407), Section 15.407**
ANSI C63.10-2013

The above equipment has been tested by **Bureau Veritas Shenzhen Co., Ltd. Dongguan Branch** and found compliance with the requirement of the above standards. The test record, data evaluation & Equipment Under Test (EUT) configurations represented herein are true and accurate accounts of the measurements of the sample's EMC characteristics under the conditions specified in this report.

PREPARED BY :  , **DATE:** Jun. 22, 2016
(Amyee Qian / Engineer)

APPROVED BY :  , **DATE:** Jun. 22, 2016
(William Chung / Manager)



2 SUMMARY OF TEST RESULTS

The EUT has been tested according to the following specifications:

APPLIED STANDARD: FCC PART 15, SUBPART E (SECTION 15.407)			
STANDARD SECTION	TEST TYPE AND LIMIT	RESULT	REMARK
15.407(b)(5)	AC Power Conducted Emission	PASS	Meet the requirement of limit. Minimum passing margin is 12.33dB at 1.366000MHz.
15.407(b)(1/2/3/4/6)	Radiated Emission & Band Edge Measurement	PASS	Meet the requirement of limit. Minimum passing margin is -2.37dB at 5725.00MHz.
15.407(a)(1/2/3)	Maximum conducted output Power	PASS	Meet the requirement of limit.
15.407(a)(1/2/3)	Peak Power Spectral Density	PASS	Meet the requirement of limit.
15.407(e)	6 dB Bandwidth	PASS	Meet the requirement of limit. (U-NII-3 Band only)
15.407(g)	Frequency Stability	PASS	Meet the requirement of limit.
15.203	Antenna Requirement	PASS	No antenna connector is used.

2.1 MEASUREMENT UNCERTAINTY

Where relevant, the following measurement uncertainty levels have been estimated for tests performed on the EUT as specified in CISPR 16-4-2:

MEASUREMENT	FREQUENCY	UNCERTAINTY
Conducted emissions	9kHz~30MHz	2.66dB
Radiated emissions	9KHz ~ 30MHz	2.74dB
	30MHz ~ 1GMHz	3.55dB
	1GHz ~ 18GHz	4.84dB
	18GHz ~ 40GHz	1.94dB

This uncertainty represents an expanded uncertainty expressed at approximately the 95% confidence level using a coverage factor of k = 2.



3 GENERAL INFORMATION

3.1 GENERAL DESCRIPTION OF EUT

EUT	LTE phone
MODEL NO.	XP5700
TYPE NUMBER	L23V013AA
POWER SUPPLY	5.0Vdc (adapter or host equipment) 3.7Vdc (battery)
MODULATION TYPE	64QAM, 16QAM, QPSK, BPSK
MODULATION TECHNOLOGY	OFDM
TRANSFER RATE	802.11a: 54.0/ 48.0/ 36.0/ 24.0/ 18.0/ 12.0/ 9.0/ 6.0Mbps 802.11n: up to MCS7
OPERATING FREQUENCY	5180 ~ 5240MHz, 5260 ~ 5320MHz 5500 ~ 5700MHz, 5745 ~ 5805MHz
NUMBER OF CHANNEL	5180 ~ 5240MHz: 4 for 802.11a, 802.11n (20MHz) 2 for 802.11n (40MHz) 5260 ~ 5320MHz: 4 for 802.11a, 802.11n (20MHz) 2 for 802.11n (40MHz) 5500 ~ 5700MHz: 8 for 802.11a, 802.11n (20MHz) 3 for 802.11n (40MHz) 5745 ~ 5805MHz: 4 for 802.11a, 802.11n (20MHz) 2 for 802.11n (40MHz)
AVERAGE POWER	12.882mW for 5180 ~ 5240MHz 13.152mW for 5260 ~ 5320MHz 12.853mW for 5500 ~ 5700MHz 13.122mW for 5745 ~ 5805MHz
ANTENNA TYPE	5180 ~ 5240MHz: PIFA Antenna with 2dBi gain 5260 ~ 5320MHz: PIFA Antenna with 2dBi gain 5500 ~ 5700MHz: PIFA Antenna with 2dBi gain 5745 ~ 5805MHz: PIFA Antenna with 2dBi gain
I/O PORTS	Refer to user's manual
CABLE SUPPLIED	USB cable: shielded, detachable, 1.1m Earphone Cable: Unshielded, Detachable, 1.2m

NOTE:

- For a more detailed features description, please refer to the manufacturer's specifications or the user's manual.
- The EUT was powered by the following adapter:



ADAPTER	
BRAND:	Sonim
MODEL:	S14C02
INPUT:	AC 100-240V, 200mA
OUTPUT:	DC 5V, 1200mA

3. The EUT matched the following USB cable and Earphone:

USB CABLE	
BRAND:	Sunway
MODEL:	N.A
SIGNAL LINE:	1.1 METER

EARPHONE	
BRAND:	Minami
MODEL:	ME-816B5-E
SIGNAL LINE:	1.2 METER

4. The EUT incorporates a SISO function. Physically, the EUT provides one completed transmitters and one receivers.

MODULATION MODE	TX FUNCTION
802.11a	1TX/1RX
802.11n (20MHz)	1TX/1RX
802.11n (40MHz)	1TX/1RX

5. For the test results, the EUT had been tested with all conditions. But only the worst case was shown in test report.



3.2 DESCRIPTION OF TEST MODES

FOR 5150 ~ 5250MHz

4 channels are provided for 802.11a, 802.11n (20MHz):

CHANNEL	FREQUENCY	CHANNEL	FREQUENCY
36	5180 MHz	44	5220 MHz
40	5200 MHz	48	5240 MHz

2 channels are provided for 802.11n (40MHz):

CHANNEL	FREQUENCY	CHANNEL	FREQUENCY
38	5190 MHz	46	5230 MHz

FOR 5250 ~ 5350MHz

4 channels are provided for 802.11a, 802.11n (20MHz):

CHANNEL	FREQUENCY	CHANNEL	FREQUENCY
52	5260 MHz	60	5300 MHz
56	5280 MHz	64	5320 MHz

2 channels are provided for 802.11n (40MHz):

CHANNEL	FREQUENCY	CHANNEL	FREQUENCY
54	5270 MHz	62	5310 MHz



FOR 5470 ~ 5725MHz

8 channels are provided for 802.11a, 802.11n (20MHz):

CHANNEL	FREQUENCY	CHANNEL	FREQUENCY
100	5500 MHz	116	5580 MHz
104	5520 MHz	132	5660 MHz
108	5540 MHz	136	5680 MHz
112	5560 MHz	140	5700 MHz

3 channels are provided for 802.11n (40MHz):

CHANNEL	FREQUENCY	CHANNEL	FREQUENCY
102	5510 MHz	134	5670 MHz
110	5550 MHz		

FOR 5725 ~ 5825MHz

4 channels are provided for 802.11a, 802.11n (20MHz):

CHANNEL	FREQUENCY	CHANNEL	FREQUENCY
149	5745MHz	161	5805MHz
153	5765MHz		
157	5785MHz		

2 channels are provided for 802.11n (40MHz):

CHANNEL	FREQUENCY	CHANNEL	FREQUENCY
151	5755MHz	159	5795MHz



3.2.1 TEST MODE APPLICABILITY AND TESTED CHANNEL DETAIL

EUT CONFIGURE MODE	APPLICABLE TO				DESCRIPTION
	RE≥1G	RE<1G	PLC	APCM	
A	√	√	√	-	Powered by Adapter with wifi(5G) link
B	-	-	-	-	Powered by Battery with wifi(5G) link
C	-	-	√	-	Powered by USB with wifi(5G) link

Where **RE≥1G**: Radiated Emission above 1GHz **RE<1G**: Radiated Emission below 1GHz
PLC: Power Line Conducted Emission **APCM**: Antenna Port Conducted Measurement

NOTE:
The EUT had been pre-tested on the positioned of each 3 axis. The worst case was found when positioned on **X-plane**.
NOTE: "-" means no effect.

RADIATED EMISSION TEST (ABOVE 1GHz):

- Pre-Scan has been conducted to determine the worst-case mode from all possible combinations between available modulations, data rates and antenna ports (if EUT with antenna diversity architecture).
- Following channel(s) was (were) selected for the final test as listed below.

EUT CONFIGURE MODE	MODE	FREQ. BAND (MHz)	AVAILABLE CHANNEL	TESTED CHANNEL	MODULATION TECHNOLOGY	MODULATION TYPE	DATA RATE (Mbps)
A	802.11a	5180-5240	36 to 48	36, 44, 48	OFDM	BPSK	6.0
A	802.11n (20MHz)		36 to 48	36, 44, 48	OFDM	BPSK	MCS0
A	802.11n (40MHz)		38 to 46	38, 46	OFDM	BPSK	MCS0
A	802.11a	5260-5320	52 to 64	52, 60, 64	OFDM	BPSK	6.0
A	802.11n (20MHz)		52 to 64	52, 60, 64	OFDM	BPSK	MCS0
A	802.11n (40MHz)		54 to 62	54, 62	OFDM	BPSK	MCS0
A	802.11a	5500-5700	100 to 140	100, 116, 140	OFDM	BPSK	6.0
A	802.11n (20MHz)		100 to 140	100, 116, 140	OFDM	BPSK	MCS0
A	802.11n (40MHz)		102 to 134	102, 110, 134	OFDM	BPSK	MCS0
A	802.11a	5725-5825	149 to 161	149, 157, 161	OFDM	BPSK	6.0
A	802.11n (20MHz)		149 to 161	149, 157, 161	OFDM	BPSK	MCS0
A	802.11n (40MHz)		151 to 159	151, 159	OFDM	BPSK	MCS0

RADIATED EMISSION TEST (BELOW 1GHz):

- Pre-Scan has been conducted to determine the worst-case mode from all possible combinations between available modulations, data rates and antenna ports (if EUT with antenna diversity architecture).
- Following channel(s) was (were) selected for the final test as listed below.

EUT CONFIGURE MODE	MODE	FREQ. BAND (MHz)	AVAILABLE CHANNEL	TESTED CHANNEL	MODULATION TECHNOLOGY	MODULATION TYPE	DATA RATE (Mbps)
A	802.11a	5180-5320	36 to 64	36	OFDM	BPSK	6.0



POWER LINE CONDUCTED EMISSION TEST:

- Pre-Scan has been conducted to determine the worst-case mode from all possible combinations between available modulations, data rates and antenna ports (if EUT with antenna diversity architecture).
- Following channel(s) was (were) selected for the final test as listed below.

EUT CONFIGURE MODE	MODE	FREQ. BAND (MHz)	AVAILABLE CHANNEL	TESTED CHANNEL	MODULATION TECHNOLOGY	MODULATION TYPE	DATA RATE (Mbps)
A	802.11a	5180-5320	36 to 64	36	OFDM	BPSK	6.0
C	802.11a	5180-5320	36 to 64	36	OFDM	BPSK	6.0

BANDEDGE MEASUREMENT:

- Pre-Scan has been conducted to determine the worst-case mode from all possible combinations between available modulations, data rates and antenna ports (if EUT with antenna diversity architecture).
- Following channel(s) was (were) selected for the final test as listed below.

EUT CONFIGURE MODE	MODE	FREQ. BAND (MHz)	AVAILABLE CHANNEL	TESTED CHANNEL	MODULATION TECHNOLOGY	MODULATION TYPE	DATA RATE (Mbps)
A	802.11a	5180-5240	36 to 48	36, 48	OFDM	BPSK	6.0
A	802.11n (20MHz)		36 to 48	36, 48	OFDM	BPSK	MCS0
A	802.11n (40MHz)		38 to 46	38, 46	OFDM	BPSK	MCS0
A	802.11a	5260-5320	52 to 64	52, 64	OFDM	BPSK	6.0
A	802.11n (20MHz)		52 to 64	52, 64	OFDM	BPSK	MCS0
A	802.11n (40MHz)		54 to 62	54, 62	OFDM	BPSK	MCS0
A	802.11a	5500-5700	100 to 140	100, 140	OFDM	BPSK	6.0
A	802.11n (20MHz)		100 to 140	100, 140	OFDM	BPSK	MCS0
A	802.11n (40MHz)		102 to 134	102, 134	OFDM	BPSK	MCS0
A	802.11a	5725-5825	149 to 161	149, 161	OFDM	BPSK	6.0
A	802.11n (20MHz)		149 to 161	149, 161	OFDM	BPSK	MCS0
A	802.11n (40MHz)		151 to 159	151, 159	OFDM	BPSK	MCS0



ANTENNA PORT CONDUCTED MEASUREMENT:

- This item includes all test value of each mode, but only includes spectrum plot of worst value of each mode.
- Pre-Scan has been conducted to determine the worst-case mode from all possible combinations between available modulations, data rates and antenna ports (if EUT with antenna diversity architecture).
- Following channel(s) was (were) selected for the final test as listed below.

EUT CONFIGURE MODE	MODE	FREQ. BAND (MHz)	AVAILABLE CHANNEL	TESTED CHANNEL	MODULATION TECHNOLOGY	MODULATION TYPE	DATA RATE (Mbps)
B	802.11a	5180-5240	36 to 48	36, 40, 48	OFDM	BPSK	6.0
B	802.11n (20MHz)		36 to 48	36, 40, 48	OFDM	BPSK	MCS0
B	802.11n (40MHz)		38 to 46	38, 46	OFDM	BPSK	MCS0
B	802.11a	5260-5320	52 to 64	52, 60, 64	OFDM	BPSK	6.0
B	802.11n (20MHz)		52 to 64	52, 60, 64	OFDM	BPSK	MCS0
B	802.11n (40MHz)		54 to 62	54, 62	OFDM	BPSK	MCS0
B	802.11a	5500-5700	100 to 140	100, 116, 140	OFDM	BPSK	6.0
B	802.11n (20MHz)		100 to 140	100, 116, 140	OFDM	BPSK	MCS0
B	802.11n (40MHz)		102 to 134	102, 110, 134	OFDM	BPSK	MCS0
B	802.11a	5725-5825	149 to 161	149, 157, 161	OFDM	BPSK	6.0
B	802.11n (20MHz)		149 to 161	149, 157, 161	OFDM	BPSK	MCS0
B	802.11n (40MHz)		151 to 159	151, 159	OFDM	BPSK	MCS0

TEST CONDITION:

APPLICABLE TO	ENVIRONMENTAL CONDITIONS	INPUT POWER	TESTED BY
RE<1G	23deg. C, 62%RH	DC 5V By Adapter	Alex Chen
RE≥1G	23deg. C, 62%RH	DC 5V By Adapter	Alex Chen
PLC	24deg. C, 61%RH	DC 5V By Adapter	Yuqiang Yin
APCM	23.5deg. C, 60%RH	DC 3.7V By battery	Yuqiang Yin



3.3 DUTY CYCLE OF TEST SIGNAL

Duty cycle of test signal is < 98%, duty factor shall be considered.

802.11a: Duty cycle = 1.362/1.563 = 0.871, Duty factor = 10 * log(1/0.871) = 0.60

802.11n (20MHz): Duty cycle = 1.273/1.495 = 0.852, Duty factor = 10 * log(1/0.852) = 0.70

802.11n (40MHz): Duty cycle = 0.633/0.845 = 0.749, Duty factor = 10 * log(1/0.749) = 1.26

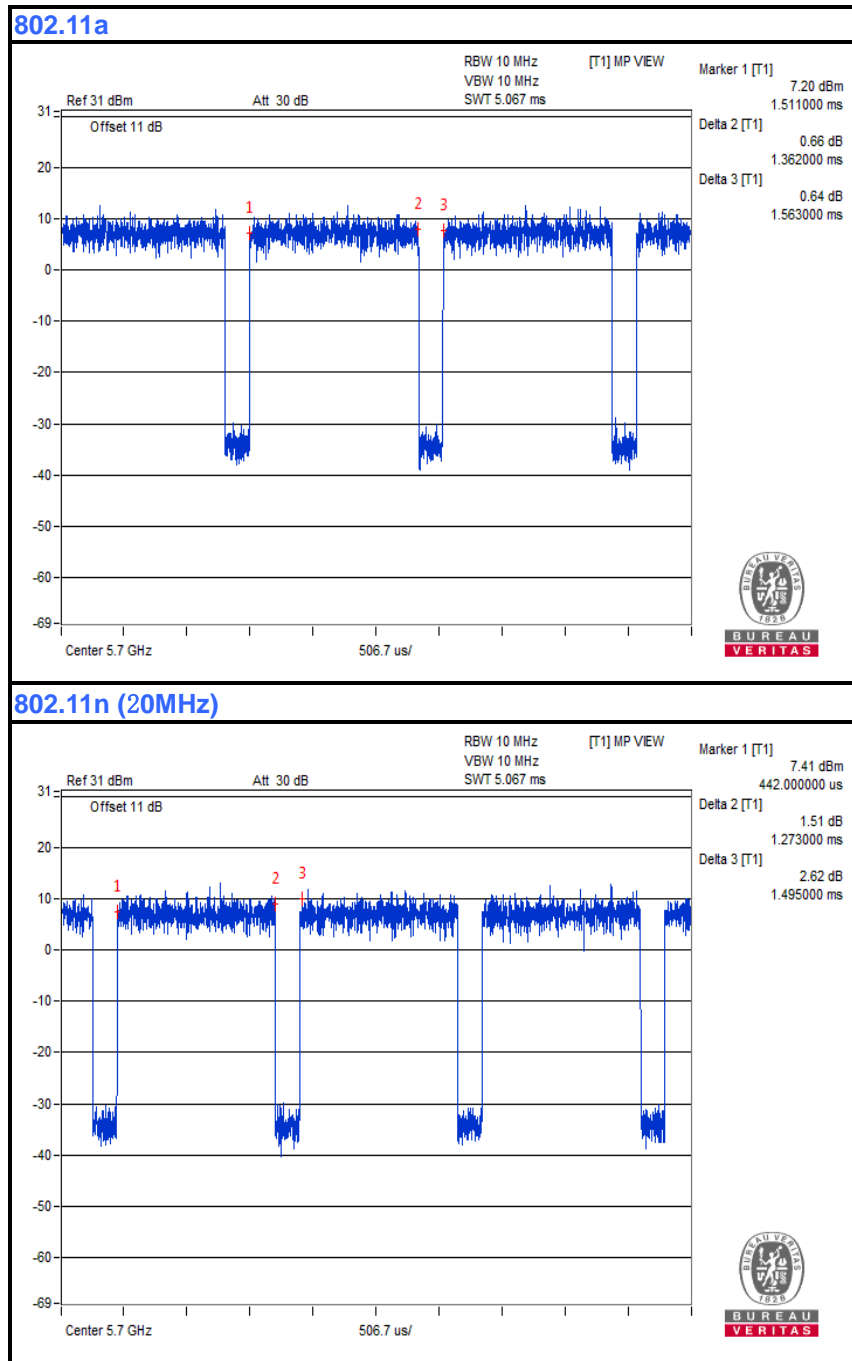



BUREAU VERITAS

Test Report No.: RF160524W004-6

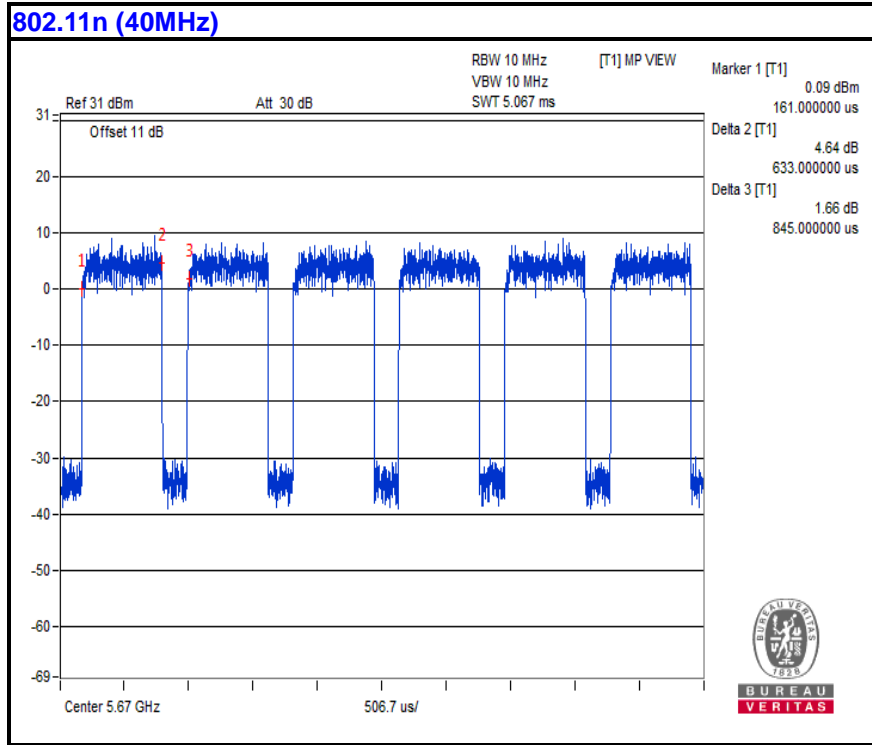



3.4 DESCRIPTION OF SUPPORT UNITS

The EUT has been tested as an independent unit together with other necessary accessories or support units. The following support units or accessories were used to form a representative test configuration during the tests.

NO.	PRODUCT	BRAND	MODEL NO.	SERIAL NO.	FCC ID
1	DC source	LONG WEI	PS-6403D	010934269	N/A
2	PC	HP	A6608CN	3CR83825X3	N/A

NO.	SIGNAL CABLE DESCRIPTION OF THE ABOVE SUPPORT UNITS
1	DC Line: Unshielded, Detachable 1.0m
2	AC Line: Unshielded, Detachable 1.5m

NOTE:

1. All power cords of the above support units are non shielded (1.8m).

3.4.1 CONFIGURATION OF SYSTEM UNDER TEST

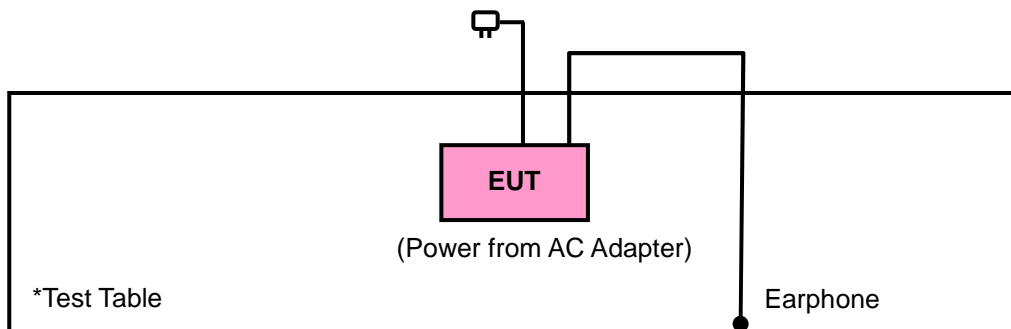

3.5 GENERAL DESCRIPTION OF APPLIED STANDARDS

The EUT is a RF Product. According to the specifications of the manufacturer, it must comply with the requirements of the following standards:

FCC Part 15, Subpart E (15.407)

KDB 789033 D02 General U-NII Test Procedures New Rules v01r02

ANSI C63.10-2013

All test items have been performed and recorded as per the above standards.

NOTE: The EUT is also considered as a kind of computer peripheral, because the connection to computer is necessary for typical use. It has been verified to comply with the requirements of FCC Part 15, Subpart B, Class B (Certification). The test report has been issued separately.

4 TEST TYPES AND RESULTS

4.1 RADIATED EMISSION AND BANDEDGE MEASUREMENT

4.1.1 LIMITS OF RADIATED EMISSION AND BANDEDGE MEASUREMENT

Radiated emissions which fall in the restricted bands must comply with the radiated emission limits specified as below table:

FREQUENCIES (MHz)	FIELD STRENGTH (microvolts/meter)	MEASUREMENT DISTANCE (meters)
0.009 ~ 0.490	2400/F(kHz)	300
0.490 ~ 1.705	24000/F(kHz)	30
1.705 ~ 30.0	30	30
30 ~ 88	100	3
88 ~ 216	150	3
216 ~ 960	200	3
Above 960	500	3

NOTE:

1. The lower limit shall apply at the transition frequencies.
2. Emission level (dBuV/m) = 20 log Emission level (uV/m).
3. For frequencies above 1000MHz, the field strength limits are based on average detector, however, the peak field strength of any emission shall not exceed the maximum permitted average limits, specified above by more than 20dB under any condition of modulation.

4.1.2 LIMITS OF UNWANTED EMISSION OUT OF THE RESTRICTED BANDS

APPLICABLE TO	LIMIT	
789033 D02 General UNII Test Procedures New Rules v01r02	FIELD STRENGTH AT 3m (dBµV/m)	
	PK : 74	AV : 54
APPLICABLE TO	EIRP LIMIT (dBm/MHz)	EQUIVALENT FIELD STRENGTH AT 3m (dBµV/m)
15.407(b)(1)	PK : -27	PK : 68.3
15.407(b)(2)		
15.407(b)(3)		
15.407(b)(4)	See note 2 (FCC 16-24)	

NOTE : 1. The following formula is used to convert the equipment isotropic radiated power (eirp) to field strength:

$$E = \frac{1000000\sqrt{30P}}{3} \mu\text{V/m, where P is the eirp (Watts).}$$

2. All emissions shall be limited to a level of -27 dBm/MHz at 75 MHz or more above or below the band edge increasing linearly to 10 dBm/MHz at 25 MHz above or below the band edge, and from 25 MHz above or below the band edge increasing linearly to a level of 15.6 dBm/MHz at 5 MHz above or below the band edge, and from 5 MHz above or below the band edge increasing linearly to a level of 27 dBm/MHz at the band edge.

4.1.3 TEST INSTRUMENTS

Equipment	Manufacturer	Model No.	Serial No.	Last Cal.	Next Cal.
EMI Test Receiver	Rohde&Schwarz	ESR7	101494	Apr. 05,16	Apr. 04,17
Bilog Antenna	Teseq	CBL 6111D	30643	Jul. 16, 15	Jul. 15, 16
Loop Antenna	Daze	ZN30900A	0708	Dec. 30, 15	Dec. 29, 16
Horn Antenna (1GHz -18GHz)	ETS -Lindgren	3117	00062558	May 30, 15	May 29, 17
Amplifier	Burgeon	BPA-530	100220	Apr. 05,16	Apr. 04,17
Pre-Amplifier (18GHz-40GHz)	EMCI	EMC 184045	980102	Nov. 20,15	Nov. 19,17
Pre-Amplifier	HP	8449B	3008A00409	Apr. 25,15	Apr. 24,17
GPS Generator+ Antenna	TOJOIN	GNSS-5000A	E1-010119	Aug. 08, 14	Aug. 07, 16
3m Semi-anechoic Chamber	ETS-LINDGREN	9m*6m*6m	NSEMC003	Mar. 12,16	Mar. 11,18
Test Software	ADT	ADT_Radiated V7.6.15.9.2	N/A	N/A	N/A

NOTE:

1. The calibration interval of the above test instruments is 12 months and the calibrations are traceable to CEPREI/CHINA, GRGT/CHINA and NIM/CHINA.
2. The test was performed in 966 Chamber.
3. The FCC Site Registration No. is 502831.



4.1.4 TEST PROCEDURES

- a. The EUT was placed on the top of a rotating table 0.8 meters (for below 1GHz) / 1.5 meters (for above 1GHz) above the ground at 3 meter chamber room for test. The table was rotated 360 degrees to determine the position of the highest radiation.
- b. The EUT was set 3 meters away from the interference-receiving antenna, which was mounted on the top of a variable-height antenna tower.
- c. The antenna is a broadband antenna, and its height is varied from one meter to four meters above the ground to determine the maximum value of the field strength. Both horizontal and vertical polarizations of the antenna are set to make the measurement.
- d. For each suspected emission, the EUT was arranged to its worst case and then the antenna was tuned to heights from 1 meter to 4 meters and the rotatable table was turned from 0 degrees to 360 degrees to find the maximum reading.
- e. The test-receiver system was set to Peak Detect Function and Specified Bandwidth with Maximum Hold Mode.
- f. If the emission level of the EUT in peak mode was 10dB lower than the limit specified, then testing could be stopped and the peak values of the EUT would be reported. Otherwise the emissions that did not have 10dB margin would be re-tested one by one using peak, quasi-peak or average method as specified and then reported in a data sheet.

NOTE:

1. The resolution bandwidth and video bandwidth of test receiver/spectrum analyzer is 120kHz for Peak detection (PK) and Quasi-peak detection (QP) at frequency below 1GHz.
2. The resolution bandwidth of test receiver/spectrum analyzer is 1MHz and video bandwidth is 3MHz for Peak detection at frequency above 1GHz.
3. The resolution bandwidth of test receiver/spectrum analyzer is 1MHz and the video bandwidth is 10Hz for Average detection (AV) at frequency above 1GHz.
4. All modes of operation were investigated and the worst-case emissions are reported.

4.1.5 DEVIATION FROM TEST STANDARD

No deviation.

4.1.6 TEST SETUP

<Frequency Range below 1GHz>

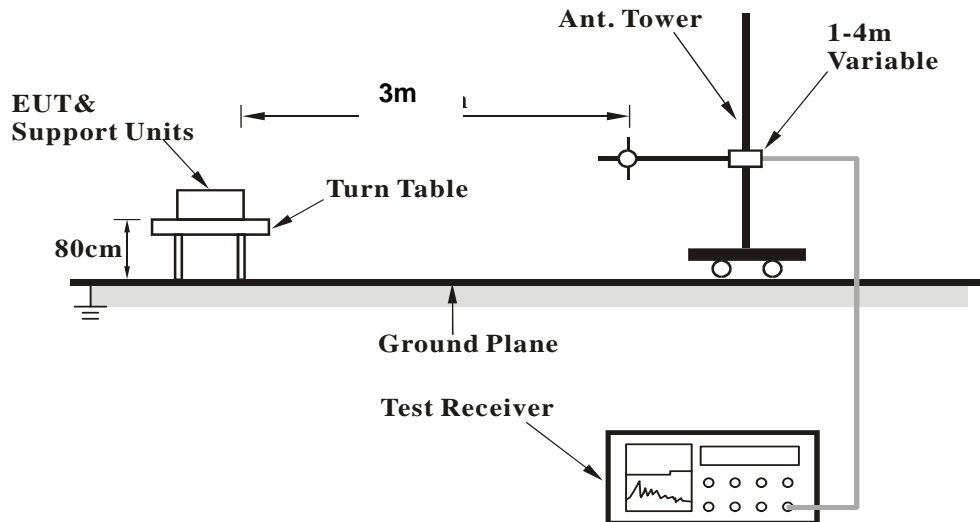

<Frequency Range above 1GHz>

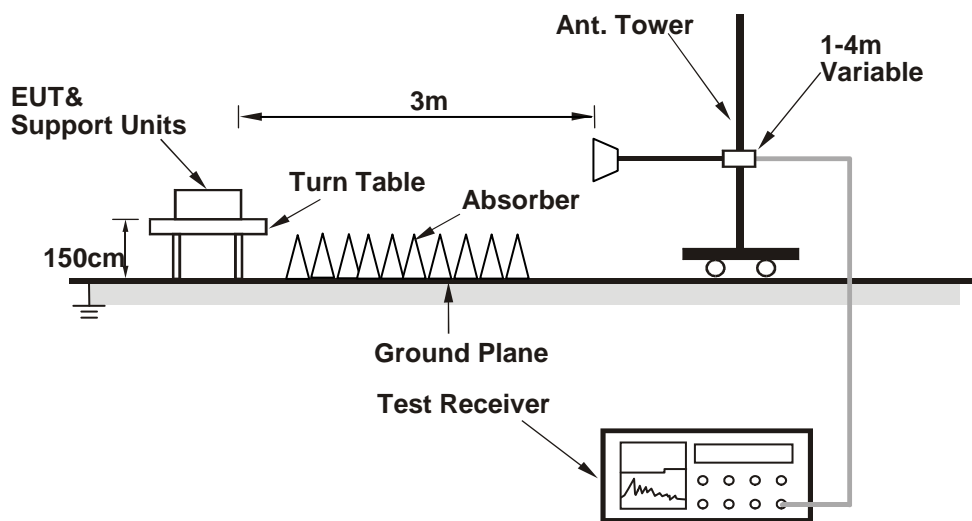

For the actual test configuration, please refer to the attached file (Test Setup Photo).



4.1.7 EUT OPERATING CONDITION

- a. Set the EUT under full load condition and placed them on a testing table.
- b. Set the transmitter part of EUT under transmission condition continuously at specific channel frequency.
- c. The necessary accessories enable the EUT in full functions.



4.1.8 TEST RESULTS

BELOW 1GHz WORST-CASE DATA:

9 KHz – 30 MHz data: the amplitude of spurious emissions attenuated more than 20 dB below the permissible value is not required in the report.

30 MHz – 1GHz data:

802.11a

CHANNEL	TX Channel 36	DETECTOR FUNCTION	Quasi-Peak (QP)
FREQUENCY RANGE	30MHz ~ 1GHz		

ANTENNA POLARITY & TEST DISTANCE: HORIZONTAL AT 3 M										
FREQ. (MHz)	EMISSION LEVEL (dBuV/m)	READ LEVEL (dBuV)	LIMIT (dBuV/m)	MARGIN (dB)	ANTENNA FACTOR (dB /m)	CABLE LOSS (dB)	PREAMP FACTOR (dB)	ANTENNA HEIGHT (cm)	TABLE ANGLE (Degree)	REMARK
36.79	18.73	42.93	40.00	-21.27	12.41	0.90	37.51	101	360	QP
91.11	28.29	56.83	43.50	-15.21	7.02	1.47	37.03	101	360	QP
135.73	19.52	46.76	43.50	-23.98	7.83	1.79	36.86	101	360	QP
183.26	21.08	45.74	43.50	-22.42	9.93	2.08	36.67	101	360	QP
559.62	20.69	34.50	46.00	-25.31	19.53	3.79	37.13	101	360	QP
824.43	27.60	37.47	46.00	-18.40	23.00	4.75	37.62	101	360	QP

REMARKS:

1. Emission level (dBuV/m) = Raw Value (dBuV) + Correction Factor (dB/m).
2. Correction Factor (dB/m) = Antenna Factor (dB/m) + Cable Factor (dB).
3. The other emission levels were very low against the limit.
4. Margin value = Emission level – Limit value.

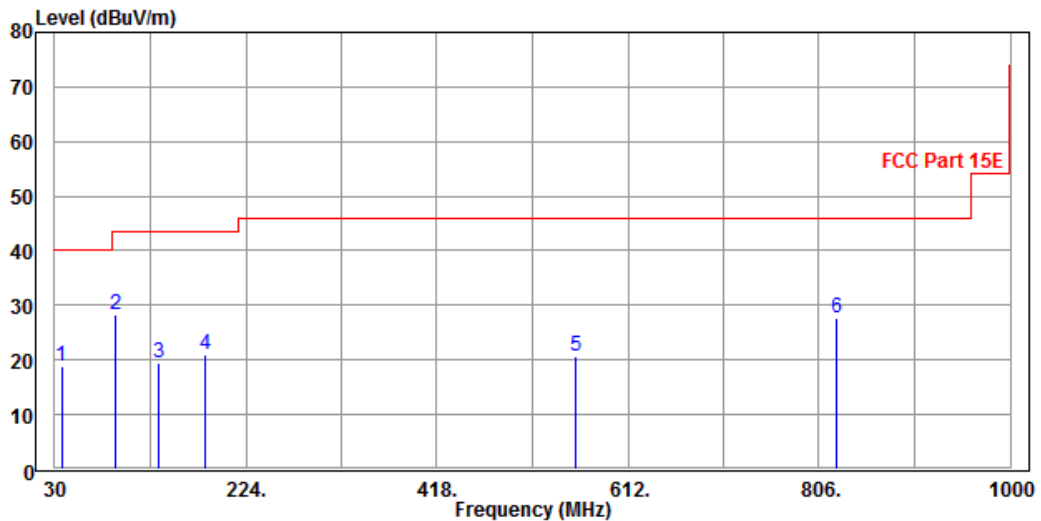



CHANNEL	Channel 36	DETECTOR FUNCTION	Quasi-Peak (QP)
FREQUENCY RANGE	30MHz ~ 1GHz		

ANTENNA POLARITY & TEST DISTANCE: VERTICAL AT 3 M										
FREQ. (MHz)	EMISSION LEVEL (dBuV/m)	READ LEVEL (dBuV)	LIMIT (dBuV/m)	MARGIN (dB)	ANTENNA FACTOR (dB /m)	CABLE LOSS (dB)	PREAMP FACTOR (dB)	ANTENNA HEIGHT (cm)	TABLE ANGLE (Degree)	REMARK
36.79	31.56	55.76	40.00	-8.44	12.41	0.90	37.51	101	300	QP
88.20	24.85	53.61	43.50	-18.65	6.85	1.45	37.06	101	300	QP
161.92	17.43	42.06	43.50	-26.07	10.17	1.94	36.74	101	300	QP
233.70	14.80	37.32	46.00	-31.20	11.65	2.36	36.53	101	300	QP
539.25	19.41	33.65	46.00	-26.59	19.15	3.68	37.07	101	300	QP
824.43	30.37	40.24	46.00	-15.63	23.00	4.75	37.62	101	300	QP

REMARKS:

1. Emission level (dBuV/m) = Raw Value (dBuV) + Correction Factor (dB/m).
2. Correction Factor (dB/m) = Antenna Factor (dB/m) + Cable Factor (dB).
3. The other emission levels were very low against the limit.
4. Margin value = Emission level – Limit value.

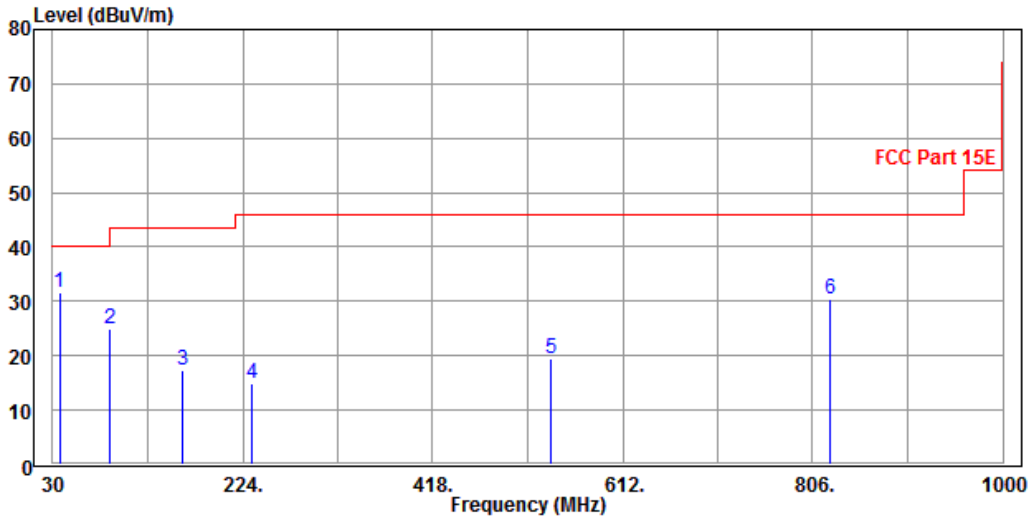



ABOVE 1GHz WORST-CASE DATA: Band 1

802.11a

CHANNEL	TX Channel 36	DETECTOR FUNCTION	Peak (PK)
FREQUENCY RANGE	1GHz ~ 40GHz		Average (AV)

ANTENNA POLARITY & TEST DISTANCE: HORIZONTAL AT 3 M										
FREQ. (MHz)	EMISSION LEVEL (dBuV/m)	READ LEVEL (dBuV)	LIMIT (dBuV/m)	MARGIN (dB)	ANTENNA FACTOR (dB /m)	CABLE LOSS (dB)	PREAMP FACTOR (dB)	ANTENNA HEIGHT (cm)	TABLE ANGLE (Degree)	REMARK
5127.7	43.80	44.71	54.00	-10.20	34.45	13.65	49.01	100	170	Average
5127.7	52.52	53.43	74.00	-21.48	34.45	13.65	49.01	100	170	Peak
*5180	91.88	92.59			34.52	13.79	49.02	100	170	Average
*5180	100.54	101.25			34.52	13.79	49.02	100	170	Peak
5350	42.01	42.09	54.00	-11.99	34.72	14.28	49.08	100	170	Average
5350	50.39	50.47	74.00	-23.61	34.72	14.28	49.08	100	170	Peak
ANTENNA POLARITY & TEST DISTANCE: VERTICAL AT 3 M										
FREQ. (MHz)	EMISSION LEVEL (dBuV/m)	READ LEVEL (dBuV)	LIMIT (dBuV/m)	MARGIN (dB)	ANTENNA FACTOR (dB /m)	CABLE LOSS (dB)	PREAMP FACTOR (dB)	ANTENNA HEIGHT (cm)	TABLE ANGLE (Degree)	REMARK
5127.8	44.57	45.48	54.00	-9.43	34.45	13.65	49.01	100	325	Average
5127.8	52.57	53.48	74.00	-21.43	34.45	13.65	49.01	100	325	Peak
*5180	94.35	95.06			34.52	13.79	49.02	100	325	Average
*5180	103.81	104.52			34.52	13.79	49.02	100	325	Peak
5368.5	42.09	42.10	54.00	-11.91	34.74	14.33	49.08	100	325	Average
5368.5	50.19	50.20	74.00	-23.81	34.74	14.33	49.08	100	325	Peak

REMARKS:

1. Emission level (dBuV/m) = Raw Value (dBuV) + Correction Factor (dB/m).
2. Correction Factor (dB/m) = Antenna Factor (dB/m) + Cable Factor (dB).
3. The other emission levels were very low against the limit.
4. Margin value = Emission level – Limit value.
5. " * ": Fundamental frequency.



CHANNEL	TX Channel 44	DETECTOR FUNCTION	Peak (PK)
FREQUENCY RANGE	1GHz ~ 40GHz		Average (AV)

ANTENNA POLARITY & TEST DISTANCE: HORIZONTAL AT 3 M										
FREQ. (MHz)	EMISSION LEVEL (dBuV/m)	READ LEVEL (dBuV)	LIMIT (dBuV/m)	MARGIN (dB)	ANTENNA FACTOR (dB /m)	CABLE LOSS (dB)	PREAMP FACTOR (dB)	ANTENNA HEIGHT (cm)	TABLE ANGLE (Degree)	REMARK
5144	42.27	43.12	54.00	-11.73	34.47	13.69	49.01	100	172	Average
5144	49.81	50.66	74.00	-24.19	34.47	13.69	49.01	100	172	Peak
*5220	92.37	92.94			34.56	13.91	49.04	100	172	Average
*5220	100.32	100.89			34.56	13.91	49.04	100	172	Peak
5350	42.04	42.12	54.00	-11.96	34.72	14.28	49.08	100	172	Average
5350	50.27	50.35	74.00	-23.73	34.72	14.28	49.08	100	172	Peak

ANTENNA POLARITY & TEST DISTANCE: VERTICAL AT 3 M										
FREQ. (MHz)	EMISSION LEVEL (dBuV/m)	READ LEVEL (dBuV)	LIMIT (dBuV/m)	MARGIN (dB)	ANTENNA FACTOR (dB /m)	CABLE LOSS (dB)	PREAMP FACTOR (dB)	ANTENNA HEIGHT (cm)	TABLE ANGLE (Degree)	REMARK
5124.7	42.24	43.16	54.00	-11.76	34.45	13.64	49.01	105	321	Average
5124.7	49.81	50.73	74.00	-24.19	34.45	13.64	49.01	105	321	Peak
*5220	94.69	95.26			34.56	13.91	49.04	105	321	Average
*5220	102.97	103.54			34.56	13.91	49.04	105	321	Peak
5350	42.06	42.14	54.00	-11.94	34.72	14.28	49.08	105	321	Average
5350	50.16	50.24	74.00	-23.84	34.72	14.28	49.08	105	321	Peak

REMARKS:

1. Emission level (dBuV/m) = Raw Value (dBuV) + Correction Factor (dB/m).
2. Correction Factor (dB/m) = Antenna Factor (dB/m) + Cable Factor (dB).
3. The other emission levels were very low against the limit.
4. Margin value = Emission level – Limit value.
5. " * ": Fundamental frequency.



CHANNEL	TX Channel 48	DETECTOR FUNCTION	Peak (PK)
FREQUENCY RANGE	1GHz ~ 40GHz		Average (AV)

ANTENNA POLARITY & TEST DISTANCE: HORIZONTAL AT 3 M										
FREQ. (MHz)	EMISSION LEVEL (dBuV/m)	READ LEVEL (dBuV)	LIMIT (dBuV/m)	MARGIN (dB)	ANTENNA FACTOR (dB /m)	CABLE LOSS (dB)	PREAMP FACTOR (dB)	ANTENNA HEIGHT (cm)	TABLE ANGLE (Degree)	REMARK
5055	41.94	43.12	54.00	-12.06	34.37	13.44	48.99	106	166	Average
5055	51.13	52.31	74.00	-22.87	34.37	13.44	48.99	106	166	Peak
*5240	91.66	92.14			34.59	13.97	49.04	106	166	Average
*5240	100.30	100.78			34.59	13.97	49.04	106	166	Peak
5350	42.07	42.15	54.00	-11.93	34.72	14.28	49.08	106	166	Average
5350	50.92	51.00	74.00	-23.08	34.72	14.28	49.08	106	166	Peak

ANTENNA POLARITY & TEST DISTANCE: VERTICAL AT 3 M										
FREQ. (MHz)	EMISSION LEVEL (dBuV/m)	READ LEVEL (dBuV)	LIMIT (dBuV/m)	MARGIN (dB)	ANTENNA FACTOR (dB /m)	CABLE LOSS (dB)	PREAMP FACTOR (dB)	ANTENNA HEIGHT (cm)	TABLE ANGLE (Degree)	REMARK
5050	43.29	44.50	54.00	-10.71	34.36	13.42	48.99	100	322	Average
5050	53.62	54.83	74.00	-20.38	34.36	13.42	48.99	100	322	Peak
*5240	94.89	95.37			34.59	13.97	49.04	100	322	Average
*5240	103.80	104.28			34.59	13.97	49.04	100	322	Peak
5352	42.18	42.25	54.00	-11.82	34.72	14.29	49.08	100	322	Average
5352	50.73	50.80	74.00	-23.27	34.72	14.29	49.08	100	322	Peak

REMARKS:

1. Emission level (dBuV/m) = Raw Value (dBuV) + Correction Factor (dB/m).
2. Correction Factor (dB/m) = Antenna Factor (dB/m) + Cable Factor (dB).
3. The other emission levels were very low against the limit.
4. Margin value = Emission level – Limit value.
5. " * ": Fundamental frequency.



802.11n (20MHz)

CHANNEL	TX Channel 36	DETECTOR FUNCTION	Peak (PK)
FREQUENCY RANGE	1GHz ~ 40GHz		Average (AV)

ANTENNA POLARITY & TEST DISTANCE: HORIZONTAL AT 3 M										
FREQ. (MHz)	EMISSION LEVEL (dBuV/m)	READ LEVEL (dBuV)	LIMIT (dBuV/m)	MARGIN (dB)	ANTENNA FACTOR (dB /m)	CABLE LOSS (dB)	PREAMP FACTOR (dB)	ANTENNA HEIGHT (cm)	TABLE ANGLE (Degree)	REMARK
5128.4	44.25	45.16	54.00	-9.75	34.45	13.65	49.01	106	168	Average
5128.4	52.28	53.19	74.00	-21.72	34.45	13.65	49.01	106	168	Peak
*5180	91.78	92.49			34.52	13.79	49.02	106	168	Average
*5180	99.93	100.64			34.52	13.79	49.02	106	168	Peak
5350	42.16	42.24	54.00	-11.84	34.72	14.28	49.08	106	168	Average
5350	52.87	52.95	74.00	-21.13	34.72	14.28	49.08	106	168	Peak

ANTENNA POLARITY & TEST DISTANCE: VERTICAL AT 3 M										
FREQ. (MHz)	EMISSION LEVEL (dBuV/m)	READ LEVEL (dBuV)	LIMIT (dBuV/m)	MARGIN (dB)	ANTENNA FACTOR (dB /m)	CABLE LOSS (dB)	PREAMP FACTOR (dB)	ANTENNA HEIGHT (cm)	TABLE ANGLE (Degree)	REMARK
5128.4	44.92	45.83	54.00	-9.08	34.45	13.65	49.01	106	322	Average
5128.4	53.78	54.69	74.00	-20.22	34.45	13.65	49.01	106	322	Peak
*5180	94.01	94.72			34.52	13.79	49.02	106	322	Average
*5180	102.95	103.66			34.52	13.79	49.02	106	322	Peak
5366	42.18	42.19	54.00	-11.82	34.74	14.33	49.08	106	322	Average
5366	52.25	52.26	74.00	-21.75	34.74	14.33	49.08	106	322	Peak

REMARKS:

1. Emission level (dBuV/m) = Raw Value (dBuV) + Correction Factor (dB/m).
2. Correction Factor (dB/m) = Antenna Factor (dB/m) + Cable Factor (dB).
3. The other emission levels were very low against the limit.
4. Margin value = Emission level – Limit value.
5. " * ": Fundamental frequency.



CHANNEL	TX Channel 44	DETECTOR FUNCTION	Peak (PK)
FREQUENCY RANGE	1GHz ~ 40GHz		Average (AV)

ANTENNA POLARITY & TEST DISTANCE: HORIZONTAL AT 3 M										
FREQ. (MHz)	EMISSION LEVEL (dBuV/m)	READ LEVEL (dBuV)	LIMIT (dBuV/m)	MARGIN (dB)	ANTENNA FACTOR (dB /m)	CABLE LOSS (dB)	PREAMP FACTOR (dB)	ANTENNA HEIGHT (cm)	TABLE ANGLE (Degree)	REMARK
5136	42.29	43.17	54.00	-11.71	34.46	13.67	49.01	102	174	Average
5136	49.97	50.85	74.00	-24.03	34.46	13.67	49.01	102	174	Peak
*5220	92.13	92.70			34.56	13.91	49.04	102	174	Average
*5220	100.75	101.32			34.56	13.91	49.04	102	174	Peak
5350	42.07	42.15	54.00	-11.93	34.72	14.28	49.08	102	174	Average
5350	51.59	51.67	74.00	-22.41	34.72	14.28	49.08	102	174	Peak

ANTENNA POLARITY & TEST DISTANCE: VERTICAL AT 3 M										
FREQ. (MHz)	EMISSION LEVEL (dBuV/m)	READ LEVEL (dBuV)	LIMIT (dBuV/m)	MARGIN (dB)	ANTENNA FACTOR (dB /m)	CABLE LOSS (dB)	PREAMP FACTOR (dB)	ANTENNA HEIGHT (cm)	TABLE ANGLE (Degree)	REMARK
5136.9	42.41	43.29	54.00	-11.59	34.46	13.67	49.01	103	320	Average
5136.9	50.39	51.27	74.00	-23.61	34.46	13.67	49.01	103	320	Peak
*5220	94.47	95.04			34.56	13.91	49.04	103	320	Average
*5220	104.08	104.65			34.56	13.91	49.04	103	320	Peak
5350	42.08	42.16	54.00	-11.92	34.72	14.28	49.08	103	320	Average
5350	50.45	50.53	74.00	-23.55	34.72	14.28	49.08	103	320	Peak

REMARKS:

1. Emission level (dBuV/m) = Raw Value (dBuV) + Correction Factor (dB/m).
2. Correction Factor (dB/m) = Antenna Factor (dB/m) + Cable Factor (dB).
3. The other emission levels were very low against the limit.
4. Margin value = Emission level – Limit value.
5. " * ": Fundamental frequency.



CHANNEL	TX Channel 48	DETECTOR FUNCTION	Peak (PK)
FREQUENCY RANGE	1GHz ~ 40GHz		Average (AV)

ANTENNA POLARITY & TEST DISTANCE: HORIZONTAL AT 3 M										
FREQ. (MHz)	EMISSION LEVEL (dBuV/m)	READ LEVEL (dBuV)	LIMIT (dBuV/m)	MARGIN (dB)	ANTENNA FACTOR (dB /m)	CABLE LOSS (dB)	PREAMP FACTOR (dB)	ANTENNA HEIGHT (cm)	TABLE ANGLE (Degree)	REMARK
5053.5	42.03	43.23	54.00	-11.97	34.36	13.43	48.99	104	176	Average
5053.5	52.04	53.24	74.00	-21.96	34.36	13.43	48.99	104	176	Peak
*5240	91.47	91.95			34.59	13.97	49.04	104	176	Average
*5240	101.15	101.63			34.59	13.97	49.04	104	176	Peak
5350	42.06	42.14	54.00	-11.94	34.72	14.28	49.08	104	176	Average
5350	53.81	53.89	74.00	-20.19	34.72	14.28	49.08	104	176	Peak

ANTENNA POLARITY & TEST DISTANCE: VERTICAL AT 3 M										
FREQ. (MHz)	EMISSION LEVEL (dBuV/m)	READ LEVEL (dBuV)	LIMIT (dBuV/m)	MARGIN (dB)	ANTENNA FACTOR (dB /m)	CABLE LOSS (dB)	PREAMP FACTOR (dB)	ANTENNA HEIGHT (cm)	TABLE ANGLE (Degree)	REMARK
5136.7	42.35	43.23	54.00	-11.65	34.46	13.67	49.01	106	328	Average
5136.7	51.54	52.42	74.00	-22.46	34.46	13.67	49.01	106	328	Peak
*5240	94.65	95.13			34.59	13.97	49.04	106	328	Average
*5240	102.97	103.45			34.59	13.97	49.04	106	328	Peak
5350	42.12	42.20	54.00	-11.88	34.72	14.28	49.08	106	328	Average
5350	50.19	50.27	74.00	-23.81	34.72	14.28	49.08	106	328	Peak

REMARKS:

1. Emission level (dBuV/m) = Raw Value (dBuV) + Correction Factor (dB/m).
2. Correction Factor (dB/m) = Antenna Factor (dB/m) + Cable Factor (dB).
3. The other emission levels were very low against the limit.
4. Margin value = Emission level – Limit value.
5. " * ": Fundamental frequency.



802.11n (40MHz)

CHANNEL	TX Channel 38	DETECTOR FUNCTION	Peak (PK)
FREQUENCY RANGE	1GHz ~ 40GHz		Average (AV)

ANTENNA POLARITY & TEST DISTANCE: HORIZONTAL AT 3 M										
FREQ. (MHz)	EMISSION LEVEL (dBuV/m)	READ LEVEL (dBuV)	LIMIT (dBuV/m)	MARGIN (dB)	ANTENNA FACTOR (dB /m)	CABLE LOSS (dB)	PREAMP FACTOR (dB)	ANTENNA HEIGHT (cm)	TABLE ANGLE (Degree)	REMARK
5150	48.59	49.41	54.00	-5.41	34.48	13.71	49.01	105	174	Average
5150	61.92	62.74	74.00	-12.08	34.48	13.71	49.01	105	174	Peak
*5190	92.58	93.26			34.53	13.82	49.03	105	174	Average
*5190	103.71	104.39			34.53	13.82	49.03	105	174	Peak
5350	41.23	41.31	54.00	-12.77	34.72	14.28	49.08	105	174	Average
5350	50.18	50.26	74.00	-23.82	34.72	14.28	49.08	105	174	Peak

ANTENNA POLARITY & TEST DISTANCE: VERTICAL AT 3 M										
FREQ. (MHz)	EMISSION LEVEL (dBuV/m)	READ LEVEL (dBuV)	LIMIT (dBuV/m)	MARGIN (dB)	ANTENNA FACTOR (dB /m)	CABLE LOSS (dB)	PREAMP FACTOR (dB)	ANTENNA HEIGHT (cm)	TABLE ANGLE (Degree)	REMARK
5150	50.24	51.06	54.00	-3.76	34.48	13.71	49.01	100	325	Average
5150	63.63	64.45	74.00	-10.37	34.48	13.71	49.01	100	325	Peak
*5190	90.38	91.06			34.53	13.82	49.03	100	325	Average
*5190	100.90	101.58			34.53	13.82	49.03	100	325	Peak
5350	42.11	42.19	54.00	-11.89	34.72	14.28	49.08	100	325	Average
5350	50.54	50.62	74.00	-23.46	34.72	14.28	49.08	100	325	Peak

REMARKS:

1. Emission level (dBuV/m) = Raw Value (dBuV) + Correction Factor (dB/m).
2. Correction Factor (dB/m) = Antenna Factor (dB/m) + Cable Factor (dB).
3. The other emission levels were very low against the limit.
4. Margin value = Emission level – Limit value.
5. " * ": Fundamental frequency.



CHANNEL	TX Channel 46	DETECTOR FUNCTION	Peak (PK)
FREQUENCY RANGE	1GHz ~ 40GHz		Average (AV)

ANTENNA POLARITY & TEST DISTANCE: HORIZONTAL AT 3 M										
FREQ. (MHz)	EMISSION LEVEL (dBuV/m)	READ LEVEL (dBuV)	LIMIT (dBuV/m)	MARGIN (dB)	ANTENNA FACTOR (dB /m)	CABLE LOSS (dB)	PREAMP FACTOR (dB)	ANTENNA HEIGHT (cm)	TABLE ANGLE (Degree)	REMARK
5126	42.63	43.55	54.00	-11.37	34.45	13.64	49.01	100	175	Average
5126	52.53	53.45	74.00	-21.47	34.45	13.64	49.01	100	175	Peak
*5230	87.79	88.31			34.58	13.94	49.04	100	175	Average
*5230	97.14	97.66			34.58	13.94	49.04	100	175	Peak
5350	42.17	42.25	54.00	-11.83	34.72	14.28	49.08	100	175	Average
5350	50.56	50.64	74.00	-23.44	34.72	14.28	49.08	100	175	Peak

ANTENNA POLARITY & TEST DISTANCE: VERTICAL AT 3 M										
FREQ. (MHz)	EMISSION LEVEL (dBuV/m)	READ LEVEL (dBuV)	LIMIT (dBuV/m)	MARGIN (dB)	ANTENNA FACTOR (dB /m)	CABLE LOSS (dB)	PREAMP FACTOR (dB)	ANTENNA HEIGHT (cm)	TABLE ANGLE (Degree)	REMARK
5127.5	42.82	43.74	54.00	-11.18	34.45	13.64	49.01	108	322	Average
5127.5	49.99	50.91	74.00	-24.01	34.45	13.64	49.01	108	322	Peak
*5230	89.93	90.45			34.58	13.94	49.04	108	322	Average
*5230	99.76	100.28			34.58	13.94	49.04	108	322	Peak
5350	42.44	42.52	54.00	-11.56	34.72	14.28	49.08	108	322	Average
5350	50.69	50.77	74.00	-23.31	34.72	14.28	49.08	108	322	Peak

REMARKS:

1. Emission level (dBuV/m) = Raw Value (dBuV) + Correction Factor (dB/m).
2. Correction Factor (dB/m) = Antenna Factor (dB/m) + Cable Factor (dB).
3. The other emission levels were very low against the limit.
4. Margin value = Emission level – Limit value.
5. " * ": Fundamental frequency.



ABOVE 1GHz WORST-CASE DATA: Band 2

802.11a

CHANNEL	TX Channel 52	DETECTOR FUNCTION	Peak (PK)
FREQUENCY RANGE	1GHz ~ 40GHz		Average (AV)

ANTENNA POLARITY & TEST DISTANCE: HORIZONTAL AT 3 M										
FREQ. (MHz)	EMISSION LEVEL (dBuV/m)	READ LEVEL (dBuV)	LIMIT (dBuV/m)	MARGIN (dB)	ANTENNA FACTOR (dB /m)	CABLE LOSS (dB)	PREAMP FACTOR (dB)	ANTENNA HEIGHT (cm)	TABLE ANGLE (Degree)	REMARK
5073.4	42.23	43.34	54.00	-11.77	34.39	13.49	48.99	100	168	Average
5073.4	50.42	51.53	74.00	-23.58	34.39	13.49	48.99	100	168	Peak
*5260	91.60	92.02			34.61	14.02	49.05	100	168	Average
*5260	100.86	101.28			34.61	14.02	49.05	100	168	Peak
5350	42.14	42.22	54.00	-11.86	34.72	14.28	49.08	100	168	Average
5350	52.80	52.88	74.00	-21.20	34.72	14.28	49.08	100	168	Peak
ANTENNA POLARITY & TEST DISTANCE: VERTICAL AT 3 M										
FREQ. (MHz)	EMISSION LEVEL (dBuV/m)	READ LEVEL (dBuV)	LIMIT (dBuV/m)	MARGIN (dB)	ANTENNA FACTOR (dB /m)	CABLE LOSS (dB)	PREAMP FACTOR (dB)	ANTENNA HEIGHT (cm)	TABLE ANGLE (Degree)	REMARK
5073	42.25	43.36	54.00	-11.75	34.39	13.49	48.99	100	325	Average
5073	50.28	51.39	74.00	-23.72	34.39	13.49	48.99	100	325	Peak
*5260	94.97	95.39			34.61	14.02	49.05	100	325	Average
*5260	105.50	105.92			34.61	14.02	49.05	100	325	Peak
5350	42.26	42.34	54.00	-11.74	34.72	14.28	49.08	100	325	Average
5350	52.57	52.65	74.00	-21.43	34.72	14.28	49.08	100	325	Peak

REMARKS:

1. Emission level (dBuV/m) = Raw Value (dBuV) + Correction Factor (dB/m).
2. Correction Factor (dB/m) = Antenna Factor (dB/m) + Cable Factor (dB).
3. The other emission levels were very low against the limit.
4. Margin value = Emission level – Limit value.
5. " * ": Fundamental frequency.



CHANNEL	TX Channel 60	DETECTOR FUNCTION	Peak (PK)
FREQUENCY RANGE	1GHz ~ 40GHz		Average (AV)

ANTENNA POLARITY & TEST DISTANCE: HORIZONTAL AT 3 M										
FREQ. (MHz)	EMISSION LEVEL (dBuV/m)	READ LEVEL (dBuV)	LIMIT (dBuV/m)	MARGIN (dB)	ANTENNA FACTOR (dB /m)	CABLE LOSS (dB)	PREAMP FACTOR (dB)	ANTENNA HEIGHT (cm)	TABLE ANGLE (Degree)	REMARK
5115	42.33	43.28	54.00	-11.67	34.44	13.61	49.00	105	172	Average
5115	50.21	51.16	74.00	-23.79	34.44	13.61	49.00	105	172	Peak
*5300	90.19	90.45			34.66	14.14	49.06	105	172	Average
*5300	99.10	99.36			34.66	14.14	49.06	105	172	Peak
5352.2	42.87	42.94	54.00	-11.13	34.72	14.29	49.08	105	172	Average
5352.2	52.54	52.61	74.00	-21.46	34.72	14.29	49.08	105	172	Peak

ANTENNA POLARITY & TEST DISTANCE: VERTICAL AT 3 M										
FREQ. (MHz)	EMISSION LEVEL (dBuV/m)	READ LEVEL (dBuV)	LIMIT (dBuV/m)	MARGIN (dB)	ANTENNA FACTOR (dB /m)	CABLE LOSS (dB)	PREAMP FACTOR (dB)	ANTENNA HEIGHT (cm)	TABLE ANGLE (Degree)	REMARK
5103.6	42.32	43.32	54.00	-11.68	34.42	13.58	49.00	104	318	Average
5103.6	49.98	50.98	74.00	-24.02	34.42	13.58	49.00	104	318	Peak
*5300	94.00	94.26			34.66	14.14	49.06	104	318	Average
*5300	102.28	102.54			34.66	14.14	49.06	104	318	Peak
5352	44.52	44.59	54.00	-9.48	34.72	14.29	49.08	104	318	Average
5352	52.20	52.27	74.00	-21.80	34.72	14.29	49.08	104	318	Peak

REMARKS:

1. Emission level (dBuV/m) = Raw Value (dBuV) + Correction Factor (dB/m).
2. Correction Factor (dB/m) = Antenna Factor (dB/m) + Cable Factor (dB).
3. The other emission levels were very low against the limit.
4. Margin value = Emission level – Limit value.
5. " * ": Fundamental frequency.



CHANNEL	TX Channel 64	DETECTOR FUNCTION	Peak (PK)
FREQUENCY RANGE	1GHz ~ 40GHz		Average (AV)

ANTENNA POLARITY & TEST DISTANCE: HORIZONTAL AT 3 M										
FREQ. (MHz)	EMISSION LEVEL (dBuV/m)	READ LEVEL (dBuV)	LIMIT (dBuV/m)	MARGIN (dB)	ANTENNA FACTOR (dB /m)	CABLE LOSS (dB)	PREAMP FACTOR (dB)	ANTENNA HEIGHT (cm)	TABLE ANGLE (Degree)	REMARK
5126	42.37	43.29	54.00	-11.63	34.45	13.64	49.01	105	170	Average
5126	50.74	51.66	74.00	-23.26	34.45	13.64	49.01	105	170	Peak
*5320	89.09	89.28			34.68	14.20	49.07	105	170	Average
*5320	97.23	97.42			34.68	14.20	49.07	105	170	Peak
5372	42.68	42.67	54.00	-11.32	34.75	14.34	49.08	105	170	Average
5372	51.98	51.97	74.00	-22.02	34.75	14.34	49.08	105	170	Peak

ANTENNA POLARITY & TEST DISTANCE: VERTICAL AT 3 M										
FREQ. (MHz)	EMISSION LEVEL (dBuV/m)	READ LEVEL (dBuV)	LIMIT (dBuV/m)	MARGIN (dB)	ANTENNA FACTOR (dB /m)	CABLE LOSS (dB)	PREAMP FACTOR (dB)	ANTENNA HEIGHT (cm)	TABLE ANGLE (Degree)	REMARK
5134.5	42.47	43.36	54.00	-11.53	34.46	13.66	49.01	100	333	Average
5134.5	50.74	51.63	74.00	-23.26	34.46	13.66	49.01	100	333	Peak
*5320	93.42	93.61			34.68	14.20	49.07	100	333	Average
*5320	101.96	102.15			34.68	14.20	49.07	100	333	Peak
5372	44.28	44.27	54.00	-9.72	34.75	14.34	49.08	100	333	Average
5372	54.66	54.65	74.00	-19.34	34.75	14.34	49.08	100	333	Peak

REMARKS:

1. Emission level (dBuV/m) = Raw Value (dBuV) + Correction Factor (dB/m).
2. Correction Factor (dB/m) = Antenna Factor (dB/m) + Cable Factor (dB).
3. The other emission levels were very low against the limit.
4. Margin value = Emission level – Limit value.
5. " * ": Fundamental frequency.



802.11n (20MHz)

CHANNEL	TX Channel 52	DETECTOR FUNCTION	Peak (PK)
FREQUENCY RANGE	1GHz ~ 40GHz		Average (AV)

ANTENNA POLARITY & TEST DISTANCE: HORIZONTAL AT 3 M										
FREQ. (MHz)	EMISSION LEVEL (dBuV/m)	READ LEVEL (dBuV)	LIMIT (dBuV/m)	MARGIN (dB)	ANTENNA FACTOR (dB /m)	CABLE LOSS (dB)	PREAMP FACTOR (dB)	ANTENNA HEIGHT (cm)	TABLE ANGLE (Degree)	REMARK
5072.3	42.12	43.23	54.00	-11.88	34.39	13.49	48.99	100	165	Average
5072.3	49.64	50.75	74.00	-24.36	34.39	13.49	48.99	100	165	Peak
*5260	90.61	91.03			34.61	14.02	49.05	100	165	Average
*5260	100.08	100.5			34.61	14.02	49.05	100	165	Peak
5350	42.15	42.23	54.00	-11.85	34.72	14.28	49.08	100	165	Average
5350	50.61	50.69	74.00	-23.39	34.72	14.28	49.08	100	165	Peak

ANTENNA POLARITY & TEST DISTANCE: VERTICAL AT 3 M										
FREQ. (MHz)	EMISSION LEVEL (dBuV/m)	READ LEVEL (dBuV)	LIMIT (dBuV/m)	MARGIN (dB)	ANTENNA FACTOR (dB /m)	CABLE LOSS (dB)	PREAMP FACTOR (dB)	ANTENNA HEIGHT (cm)	TABLE ANGLE (Degree)	REMARK
5073.7	42.15	43.26	54.00	-11.85	34.39	13.49	48.99	105	322	Average
5073.7	53.12	54.23	74.00	-20.88	34.39	13.49	48.99	105	322	Peak
*5260	94.05	94.47			34.61	14.02	49.05	105	322	Average
*5260	102.63	103.05			34.61	14.02	49.05	105	322	Peak
5350	42.25	42.33	54.00	-11.75	34.72	14.28	49.08	105	322	Average
5350	50.57	50.65	74.00	-23.43	34.72	14.28	49.08	105	322	Peak

REMARKS:

1. Emission level (dBuV/m) = Raw Value (dBuV) + Correction Factor (dB/m).
2. Correction Factor (dB/m) = Antenna Factor (dB/m) + Cable Factor (dB).
3. The other emission levels were very low against the limit.
4. Margin value = Emission level – Limit value.
5. " * ": Fundamental frequency.



CHANNEL	TX Channel 60	DETECTOR FUNCTION	Peak (PK)
FREQUENCY RANGE	1GHz ~ 40GHz		Average (AV)

ANTENNA POLARITY & TEST DISTANCE: HORIZONTAL AT 3 M										
FREQ. (MHz)	EMISSION LEVEL (dBuV/m)	READ LEVEL (dBuV)	LIMIT (dBuV/m)	MARGIN (dB)	ANTENNA FACTOR (dB /m)	CABLE LOSS (dB)	PREAMP FACTOR (dB)	ANTENNA HEIGHT (cm)	TABLE ANGLE (Degree)	REMARK
5052	42.04	43.24	54.00	-11.96	34.36	13.43	48.99	107	174	Average
5052	52.71	53.91	74.00	-21.29	34.36	13.43	48.99	107	174	Peak
*5300	89.36	89.62			34.66	14.14	49.06	107	174	Average
*5300	98.28	98.54			34.66	14.14	49.06	107	174	Peak
5351.4	42.91	42.98	54.00	-11.09	34.72	14.29	49.08	107	174	Average
5351.4	50.92	50.99	74.00	-23.08	34.72	14.29	49.08	107	174	Peak

ANTENNA POLARITY & TEST DISTANCE: VERTICAL AT 3 M										
FREQ. (MHz)	EMISSION LEVEL (dBuV/m)	READ LEVEL (dBuV)	LIMIT (dBuV/m)	MARGIN (dB)	ANTENNA FACTOR (dB /m)	CABLE LOSS (dB)	PREAMP FACTOR (dB)	ANTENNA HEIGHT (cm)	TABLE ANGLE (Degree)	REMARK
5103	42.23	43.24	54.00	-11.77	34.42	13.57	49.00	108	328	Average
5103	49.54	50.55	74.00	-24.46	34.42	13.57	49.00	108	328	Peak
*5300	93.07	93.33			34.66	14.14	49.06	108	328	Average
*5300	101.59	101.85			34.66	14.14	49.06	108	328	Peak
5350	44.70	44.78	54.00	-9.30	34.72	14.28	49.08	108	328	Average
5350	53.34	53.42	74.00	-20.66	34.72	14.28	49.08	108	328	Peak

REMARKS:

1. Emission level (dBuV/m) = Raw Value (dBuV) + Correction Factor (dB/m).
2. Correction Factor (dB/m) = Antenna Factor (dB/m) + Cable Factor (dB).
3. The other emission levels were very low against the limit.
4. Margin value = Emission level – Limit value.
5. " * ": Fundamental frequency.



CHANNEL	TX Channel 64	DETECTOR FUNCTION	Peak (PK)
FREQUENCY RANGE	1GHz ~ 40GHz		Average (AV)

ANTENNA POLARITY & TEST DISTANCE: HORIZONTAL AT 3 M										
FREQ. (MHz)	EMISSION LEVEL (dBuV/m)	READ LEVEL (dBuV)	LIMIT (dBuV/m)	MARGIN (dB)	ANTENNA FACTOR (dB /m)	CABLE LOSS (dB)	PREAMP FACTOR (dB)	ANTENNA HEIGHT (cm)	TABLE ANGLE (Degree)	REMARK
5133.9	42.40	43.29	54.00	-11.60	34.46	13.66	49.01	110	176	Average
5133.9	51.39	52.28	74.00	-22.61	34.46	13.66	49.01	110	176	Peak
*5320	88.52	88.71			34.68	14.20	49.07	110	176	Average
*5320	98.08	98.27			34.68	14.20	49.07	110	176	Peak
5350	42.62	42.70	54.00	-11.38	34.72	14.28	49.08	110	176	Average
5350	52.52	52.60	74.00	-21.48	34.72	14.28	49.08	110	176	Peak

ANTENNA POLARITY & TEST DISTANCE: VERTICAL AT 3 M										
FREQ. (MHz)	EMISSION LEVEL (dBuV/m)	READ LEVEL (dBuV)	LIMIT (dBuV/m)	MARGIN (dB)	ANTENNA FACTOR (dB /m)	CABLE LOSS (dB)	PREAMP FACTOR (dB)	ANTENNA HEIGHT (cm)	TABLE ANGLE (Degree)	REMARK
5135.6	42.45	43.33	54.00	-11.55	34.46	13.67	49.01	106	330	Average
5135.6	50.75	51.63	74.00	-23.25	34.46	13.67	49.01	106	330	Peak
*5320	92.90	93.09			34.68	14.20	49.07	106	330	Average
*5320	101.62	101.81			34.68	14.20	49.07	106	330	Peak
5350	44.31	44.39	54.00	-9.69	34.72	14.28	49.08	106	330	Average
5350	56.78	56.86	74.00	-17.22	34.72	14.28	49.08	106	330	Peak

REMARKS:

1. Emission level (dBuV/m) = Raw Value (dBuV) + Correction Factor (dB/m).
2. Correction Factor (dB/m) = Antenna Factor (dB/m) + Cable Factor (dB).
3. The other emission levels were very low against the limit.
4. Margin value = Emission level – Limit value.
5. " * ": Fundamental frequency.



802.11n (40MHz)

CHANNEL	TX Channel 54	DETECTOR FUNCTION	Peak (PK)
FREQUENCY RANGE	1GHz ~ 40GHz		Average (AV)

ANTENNA POLARITY & TEST DISTANCE: HORIZONTAL AT 3 M										
FREQ. (MHz)	EMISSION LEVEL (dBuV/m)	READ LEVEL (dBuV)	LIMIT (dBuV/m)	MARGIN (dB)	ANTENNA FACTOR (dB /m)	CABLE LOSS (dB)	PREAMP FACTOR (dB)	ANTENNA HEIGHT (cm)	TABLE ANGLE (Degree)	REMARK
5150	42.44	43.26	54.00	-11.56	34.48	13.71	49.01	108	175	Average
5150	50.28	51.10	74.00	-23.72	34.48	13.71	49.01	108	175	Peak
*5270	86.77	87.15			34.62	14.05	49.05	108	175	Average
*5270	96.41	96.79			34.62	14.05	49.05	108	175	Peak
5350	42.11	42.19	54.00	-11.89	34.72	14.28	49.08	108	175	Average
5350	54.75	54.83	74.00	-19.25	34.72	14.28	49.08	108	175	Peak

ANTENNA POLARITY & TEST DISTANCE: VERTICAL AT 3 M										
FREQ. (MHz)	EMISSION LEVEL (dBuV/m)	READ LEVEL (dBuV)	LIMIT (dBuV/m)	MARGIN (dB)	ANTENNA FACTOR (dB /m)	CABLE LOSS (dB)	PREAMP FACTOR (dB)	ANTENNA HEIGHT (cm)	TABLE ANGLE (Degree)	REMARK
5150	42.55	43.37	54.00	-11.45	34.48	13.71	49.01	105	321	Average
5150	50.60	51.42	74.00	-23.40	34.48	13.71	49.01	105	321	Peak
*5270	90.24	90.62			34.62	14.05	49.05	105	321	Average
*5270	99.81	100.19			34.62	14.05	49.05	105	321	Peak
5350	42.57	42.65	54.00	-11.43	34.72	14.28	49.08	105	321	Average
5350	52.41	52.49	74.00	-21.59	34.72	14.28	49.08	105	321	Peak

REMARKS:

1. Emission level (dBuV/m) = Raw Value (dBuV) + Correction Factor (dB/m).
2. Correction Factor (dB/m) = Antenna Factor (dB/m) + Cable Factor (dB).
3. The other emission levels were very low against the limit.
4. Margin value = Emission level – Limit value.
5. " * ": Fundamental frequency.



CHANNEL	TX Channel 62	DETECTOR FUNCTION	Peak (PK)
FREQUENCY RANGE	1GHz ~ 40GHz		Average (AV)

ANTENNA POLARITY & TEST DISTANCE: HORIZONTAL AT 3 M										
FREQ. (MHz)	EMISSION LEVEL (dBuV/m)	READ LEVEL (dBuV)	LIMIT (dBuV/m)	MARGIN (dB)	ANTENNA FACTOR (dB /m)	CABLE LOSS (dB)	PREAMP FACTOR (dB)	ANTENNA HEIGHT (cm)	TABLE ANGLE (Degree)	REMARK
5053	41.92	43.12	54.00	-12.08	34.36	13.43	48.99	110	170	Average
5053	53.47	54.67	74.00	-20.53	34.36	13.43	48.99	110	170	Peak
*5310	85.37	85.59			34.67	14.17	49.06	110	170	Average
*5310	95.43	95.65			34.67	14.17	49.06	110	170	Peak
5354	45.07	45.14	54.00	-8.93	34.72	14.29	49.08	110	170	Average
5354	58.23	58.30	74.00	-15.77	34.72	14.29	49.08	110	170	Peak

ANTENNA POLARITY & TEST DISTANCE: VERTICAL AT 3 M										
FREQ. (MHz)	EMISSION LEVEL (dBuV/m)	READ LEVEL (dBuV)	LIMIT (dBuV/m)	MARGIN (dB)	ANTENNA FACTOR (dB /m)	CABLE LOSS (dB)	PREAMP FACTOR (dB)	ANTENNA HEIGHT (cm)	TABLE ANGLE (Degree)	REMARK
5052	42.00	43.20	54.00	-12.00	34.36	13.43	48.99	100	325	Average
5052	51.75	52.95	74.00	-22.25	34.36	13.43	48.99	100	325	Peak
*5310	89.90	90.12			34.67	14.17	49.06	100	325	Average
*5310	99.36	99.58			34.67	14.17	49.06	100	325	Peak
5350	49.66	49.74	54.00	-4.34	34.72	14.28	49.08	100	325	Average
5350	64.87	64.95	74.00	-9.13	34.72	14.28	49.08	100	325	Peak

REMARKS:

1. Emission level (dBuV/m) = Raw Value (dBuV) + Correction Factor (dB/m).
2. Correction Factor (dB/m) = Antenna Factor (dB/m) + Cable Factor (dB).
3. The other emission levels were very low against the limit.
4. Margin value = Emission level – Limit value.
5. " * ": Fundamental frequency.



ABOVE 1GHz WORST-CASE DATA: Band 3

802.11a

CHANNEL	TX Channel 100	DETECTOR FUNCTION	Peak (PK)
FREQUENCY RANGE	1GHz ~ 40GHz		Average (AV)

ANTENNA POLARITY & TEST DISTANCE: HORIZONTAL AT 3 M										
FREQ. (MHz)	EMISSION LEVEL (dBuV/m)	READ LEVEL (dBuV)	LIMIT (dBuV/m)	MARGIN (dB)	ANTENNA FACTOR (dB /m)	CABLE LOSS (dB)	PREAMP FACTOR (dB)	ANTENNA HEIGHT (cm)	TABLE ANGLE (Degree)	REMARK
5447.6	43.51	43.21	54.00	-10.49	34.84	14.56	49.10	100	222	Average
5447.6	51.68	51.38	74.00	-22.32	34.84	14.56	49.10	100	222	Peak
#5470	59.01	58.64	68.3	-9.29	34.86	14.62	49.11	100	222	Peak
*5500	91.13	90.64			34.90	14.71	49.12	100	222	Average
*5500	99.43	98.94			34.90	14.71	49.12	100	222	Peak
#5725	58.59	56.38	68.3	-9.71	35.17	16.18	49.14	100	222	Peak
ANTENNA POLARITY & TEST DISTANCE: VERTICAL AT 3 M										
FREQ. (MHz)	EMISSION LEVEL (dBuV/m)	READ LEVEL (dBuV)	LIMIT (dBuV/m)	MARGIN (dB)	ANTENNA FACTOR (dB /m)	CABLE LOSS (dB)	PREAMP FACTOR (dB)	ANTENNA HEIGHT (cm)	TABLE ANGLE (Degree)	REMARK
5447.6	44.83	44.53	54.00	-9.17	34.84	14.56	49.1	105	326	Average
5447.6	56.33	56.03	74.00	-17.67	34.84	14.56	49.1	105	326	Peak
#5470	59.62	59.25	68.3	-8.68	34.86	14.62	49.11	105	326	Peak
*5500	93.84	93.35			34.9	14.71	49.12	105	326	Average
*5500	101.31	100.82			34.9	14.71	49.12	105	326	Peak
#5725	57.93	55.72	68.3	-10.37	35.17	16.18	49.14	105	326	Peak

REMARKS:

1. Emission level (dBuV/m) = Raw Value (dBuV) + Correction Factor (dB/m).
2. Correction Factor (dB/m) = Antenna Factor (dB/m) + Cable Factor (dB).
3. The other emission levels were very low against the limit.
4. Margin value = Emission level – Limit value.
5. " * ": Fundamental frequency.
6. " # ": The radiated frequency is out of the restricted band.



CHANNEL	TX Channel 116	DETECTOR FUNCTION	Peak (PK)
FREQUENCY RANGE	1GHz ~ 40GHz		Average (AV)

ANTENNA POLARITY & TEST DISTANCE: HORIZONTAL AT 3 M										
FREQ. (MHz)	EMISSION LEVEL (dBuV/m)	READ LEVEL (dBuV)	LIMIT (dBuV/m)	MARGIN (dB)	ANTENNA FACTOR (dB /m)	CABLE LOSS (dB)	PREAMP FACTOR (dB)	ANTENNA HEIGHT (cm)	TABLE ANGLE (Degree)	REMARK
5451.5	42.12	41.82	54.00	-11.88	34.84	14.56	49.10	100	225	Average
5451.5	50.46	50.16	74.00	-23.54	34.84	14.56	49.10	100	225	Peak
#5470	54.56	54.19	68.3	-13.74	34.86	14.62	49.11	100	225	Peak
*5580	91.89	90.79			35.00	15.23	49.13	100	225	Average
*5580	99.35	98.25			35.00	15.23	49.13	100	225	Peak
#5725	57.89	55.68	68.3	-10.41	35.17	16.18	49.14	100	225	Peak

ANTENNA POLARITY & TEST DISTANCE: VERTICAL AT 3 M										
FREQ. (MHz)	EMISSION LEVEL (dBuV/m)	READ LEVEL (dBuV)	LIMIT (dBuV/m)	MARGIN (dB)	ANTENNA FACTOR (dB /m)	CABLE LOSS (dB)	PREAMP FACTOR (dB)	ANTENNA HEIGHT (cm)	TABLE ANGLE (Degree)	REMARK
5451.5	42.16	41.86	54.00	-11.84	34.84	14.57	49.11	105	326	Average
5451.5	50.33	50.03	74.00	-23.67	34.84	14.57	49.11	105	326	Peak
#5470	54.87	54.50	68.3	-13.43	34.86	14.62	49.11	105	326	Peak
*5580	93.86	92.76			35.00	15.23	49.13	105	326	Average
*5580	101.09	99.99			35.00	15.23	49.13	105	326	Peak
#5725	57.82	55.61	68.3	-10.48	35.17	16.18	49.14	105	326	Peak

REMARKS:

1. Emission level (dBuV/m) = Raw Value (dBuV) + Correction Factor (dB/m).
2. Correction Factor (dB/m) = Antenna Factor (dB/m) + Cable Factor (dB).
3. The other emission levels were very low against the limit.
4. Margin value = Emission level – Limit value.
5. " * ": Fundamental frequency.
6. " # ": The radiated frequency is out of the restricted band.



CHANNEL	TX Channel 140	DETECTOR FUNCTION	Peak (PK)
FREQUENCY RANGE	1GHz ~ 40GHz		Average (AV)

ANTENNA POLARITY & TEST DISTANCE: HORIZONTAL AT 3 M										
FREQ. (MHz)	EMISSION LEVEL (dBuV/m)	READ LEVEL (dBuV)	LIMIT (dBuV/m)	MARGIN (dB)	ANTENNA FACTOR (dB /m)	CABLE LOSS (dB)	PREAMP FACTOR (dB)	ANTENNA HEIGHT (cm)	TABLE ANGLE (Degree)	REMARK
5450.5	42.36	42.06	54.00	-11.64	34.84	14.57	49.11	100	225	Average
5450.5	50.86	50.56	74.00	-23.14	34.84	14.57	49.11	100	225	Peak
#5470	54.86	54.49	68.3	-13.44	34.86	14.62	49.11	100	225	Peak
*5700	95.41	93.40			35.14	16.01	49.14	100	225	Average
*5700	103.76	101.75			35.14	16.01	49.14	100	225	Peak
#5725	65.29	63.08	68.3	-3.01	35.17	16.18	49.14	100	225	Peak
ANTENNA POLARITY & TEST DISTANCE: VERTICAL AT 3 M										
FREQ. (MHz)	EMISSION LEVEL (dBuV/m)	READ LEVEL (dBuV)	LIMIT (dBuV/m)	MARGIN (dB)	ANTENNA FACTOR (dB /m)	CABLE LOSS (dB)	PREAMP FACTOR (dB)	ANTENNA HEIGHT (cm)	TABLE ANGLE (Degree)	REMARK
5400	42.45	42.34	54.00	-11.55	34.78	14.42	49.09	105	328	Average
5400	52.09	51.98	74.00	-21.91	34.78	14.42	49.09	105	328	Peak
#5470	53.66	53.29	68.3	-14.64	34.86	14.62	49.11	105	328	Peak
*5700	93.80	91.79			35.14	16.01	49.14	105	328	Average
*5700	102.22	100.21			35.14	16.01	49.14	105	328	Peak
#5725	65.75	63.54	68.3	-2.55	35.17	16.18	49.14	105	328	Peak

REMARKS:

1. Emission level (dBuV/m) = Raw Value (dBuV) + Correction Factor (dB/m).
2. Correction Factor (dB/m) = Antenna Factor (dB/m) + Cable Factor (dB).
3. The other emission levels were very low against the limit.
4. Margin value = Emission level – Limit value.
5. " * ": Fundamental frequency.
6. " # ": The radiated frequency is out of the restricted band.



802.11n (20MHz)

CHANNEL	TX Channel 100	DETECTOR FUNCTION	Peak (PK)
FREQUENCY RANGE	1GHz ~ 40GHz		Average (AV)

ANTENNA POLARITY & TEST DISTANCE: HORIZONTAL AT 3 M										
FREQ. (MHz)	EMISSION LEVEL (dBuV/m)	READ LEVEL (dBuV)	LIMIT (dBuV/m)	MARGIN (dB)	ANTENNA FACTOR (dB /m)	CABLE LOSS (dB)	PREAMP FACTOR (dB)	ANTENNA HEIGHT (cm)	TABLE ANGLE (Degree)	REMARK
5448	43.65	43.35	54.00	-10.35	34.84	14.56	49.10	105	226	Average
5448	50.80	50.50	74.00	-23.20	34.84	14.56	49.10	105	226	Peak
#5470	58.03	57.66	68.3	-10.27	34.86	14.62	49.11	105	226	Peak
*5500	90.67	90.18			34.90	14.71	49.12	105	226	Average
*5500	98.94	98.45			34.90	14.71	49.12	105	226	Peak
#5725	58.08	55.87	68.3	-10.22	35.17	16.18	49.14	105	226	Peak

ANTENNA POLARITY & TEST DISTANCE: VERTICAL AT 3 M										
FREQ. (MHz)	EMISSION LEVEL (dBuV/m)	READ LEVEL (dBuV)	LIMIT (dBuV/m)	MARGIN (dB)	ANTENNA FACTOR (dB /m)	CABLE LOSS (dB)	PREAMP FACTOR (dB)	ANTENNA HEIGHT (cm)	TABLE ANGLE (Degree)	REMARK
5448	45.31	45.01	54.00	-8.69	34.84	14.56	49.1	100	330	Average
5448	52.42	52.12	74.00	-21.58	34.84	14.56	49.1	100	330	Peak
#5470	61.55	61.18	68.3	-6.75	34.86	14.62	49.11	100	330	Peak
*5500	93.88	93.39			34.90	14.71	49.12	100	330	Average
*5500	101.77	101.28			34.90	14.71	49.12	100	330	Peak
#5725	58.29	56.08	68.3	-10.01	35.17	16.18	49.14	100	330	Peak

REMARKS:

1. Emission level (dBuV/m) = Raw Value (dBuV) + Correction Factor (dB/m).
2. Correction Factor (dB/m) = Antenna Factor (dB/m) + Cable Factor (dB).
3. The other emission levels were very low against the limit.
4. Margin value = Emission level – Limit value.
5. " * ": Fundamental frequency.
6. " # ": The radiated frequency is out of the restricted band.



CHANNEL	TX Channel 116	DETECTOR FUNCTION	Peak (PK)
FREQUENCY RANGE	1GHz ~ 40GHz		Average (AV)

ANTENNA POLARITY & TEST DISTANCE: HORIZONTAL AT 3 M										
FREQ. (MHz)	EMISSION LEVEL (dBuV/m)	READ LEVEL (dBuV)	LIMIT (dBuV/m)	MARGIN (dB)	ANTENNA FACTOR (dB /m)	CABLE LOSS (dB)	PREAMP FACTOR (dB)	ANTENNA HEIGHT (cm)	TABLE ANGLE (Degree)	REMARK
5460	42.24	41.90	54.00	-11.76	34.85	14.60	49.11	106	232	Average
5460	50.65	50.31	74.00	-23.35	34.85	14.60	49.11	106	232	Peak
#5470	55.24	54.87	68.3	-13.06	34.86	14.62	49.11	106	232	Peak
*5580	91.68	90.58			35.00	15.23	49.13	106	232	Average
*5580	98.90	97.80			35.00	15.23	49.13	106	232	Peak
#5725	57.11	54.90	68.3	-11.19	35.17	16.18	49.14	106	232	Peak

ANTENNA POLARITY & TEST DISTANCE: VERTICAL AT 3 M										
FREQ. (MHz)	EMISSION LEVEL (dBuV/m)	READ LEVEL (dBuV)	LIMIT (dBuV/m)	MARGIN (dB)	ANTENNA FACTOR (dB /m)	CABLE LOSS (dB)	PREAMP FACTOR (dB)	ANTENNA HEIGHT (cm)	TABLE ANGLE (Degree)	REMARK
5450	41.95	41.64	54.00	-12.05	34.84	14.57	49.10	100	328	Average
5450	51.55	51.24	74.00	-22.45	34.84	14.57	49.10	100	328	Peak
#5470	54.11	53.74	68.3	-14.19	34.86	14.62	49.11	100	328	Peak
*5580	94.05	92.95			35.00	15.23	49.13	100	328	Average
*5580	102.08	100.98			35.00	15.23	49.13	100	328	Peak
#5725	58.27	56.06	68.3	-10.03	35.17	16.18	49.14	100	328	Peak

REMARKS:

1. Emission level (dBuV/m) = Raw Value (dBuV) + Correction Factor (dB/m).
2. Correction Factor (dB/m) = Antenna Factor (dB/m) + Cable Factor (dB).
3. The other emission levels were very low against the limit.
4. Margin value = Emission level – Limit value.
5. " * ": Fundamental frequency.
6. " # ": The radiated frequency is out of the restricted band.



CHANNEL	TX Channel 140	DETECTOR FUNCTION	Peak (PK)
FREQUENCY RANGE	1GHz ~ 40GHz		Average (AV)

ANTENNA POLARITY & TEST DISTANCE: HORIZONTAL AT 3 M										
FREQ. (MHz)	EMISSION LEVEL (dBuV/m)	READ LEVEL (dBuV)	LIMIT (dBuV/m)	MARGIN (dB)	ANTENNA FACTOR (dB /m)	CABLE LOSS (dB)	PREAMP FACTOR (dB)	ANTENNA HEIGHT (cm)	TABLE ANGLE (Degree)	REMARK
5450	42.22	41.91	54.00	-11.78	34.84	14.57	49.10	108	228	Average
5450	50.97	50.66	74.00	-23.03	34.84	14.57	49.10	108	228	Peak
#5470	53.60	53.23	68.3	-14.70	34.86	14.62	49.11	108	228	Peak
*5700	92.18	90.17			35.14	16.01	49.14	108	228	Average
*5700	100.29	98.28			35.14	16.01	49.14	108	228	Peak
#5725	63.54	61.33	68.3	-4.76	35.17	16.18	49.14	108	228	Peak

ANTENNA POLARITY & TEST DISTANCE: VERTICAL AT 3 M										
FREQ. (MHz)	EMISSION LEVEL (dBuV/m)	READ LEVEL (dBuV)	LIMIT (dBuV/m)	MARGIN (dB)	ANTENNA FACTOR (dB /m)	CABLE LOSS (dB)	PREAMP FACTOR (dB)	ANTENNA HEIGHT (cm)	TABLE ANGLE (Degree)	REMARK
5400	42.19	42.08	54.00	-11.81	34.78	14.42	49.09	100	330	Average
5400	50.80	50.69	74.00	-23.20	34.78	14.42	49.09	100	330	Peak
#5470	53.90	53.53	68.3	-14.40	34.86	14.62	49.11	100	330	Peak
*5700	92.24	90.23			35.14	16.01	49.14	100	330	Average
*5700	100.86	98.85			35.14	16.01	49.14	100	330	Peak
#5725	65.93	63.61	68.3	-2.37	35.19	16.27	49.14	100	330	Peak

REMARKS:

1. Emission level (dBuV/m) = Raw Value (dBuV) + Correction Factor (dB/m).
2. Correction Factor (dB/m) = Antenna Factor (dB/m) + Cable Factor (dB).
3. The other emission levels were very low against the limit.
4. Margin value = Emission level – Limit value.
5. " * " : Fundamental frequency.
6. " # " : The radiated frequency is out of the restricted band.



802.11n (40MHz)

CHANNEL	TX Channel 102	DETECTOR FUNCTION	Peak (PK)
FREQUENCY RANGE	1GHz ~ 40GHz		Average (AV)

ANTENNA POLARITY & TEST DISTANCE: HORIZONTAL AT 3 M										
FREQ. (MHz)	EMISSION LEVEL (dBuV/m)	READ LEVEL (dBuV)	LIMIT (dBuV/m)	MARGIN (dB)	ANTENNA FACTOR (dB /m)	CABLE LOSS (dB)	PREAMP FACTOR (dB)	ANTENNA HEIGHT (cm)	TABLE ANGLE (Degree)	REMARK
5460	43.79	43.45	54.00	-10.21	34.85	14.60	49.11	100	230	Average
5460	52.08	51.74	74.00	-21.92	34.85	14.60	49.11	100	230	Peak
#5470	60.07	59.70	68.3	-8.23	34.86	14.62	49.11	100	230	Peak
*5510	86.66	86.09			34.91	14.78	49.12	100	230	Average
*5510	96.73	96.16			34.91	14.78	49.12	100	230	Peak
#5725	56.68	54.47	68.3	-11.62	35.17	16.18	49.14	100	230	Peak

ANTENNA POLARITY & TEST DISTANCE: VERTICAL AT 3 M										
FREQ. (MHz)	EMISSION LEVEL (dBuV/m)	READ LEVEL (dBuV)	LIMIT (dBuV/m)	MARGIN (dB)	ANTENNA FACTOR (dB /m)	CABLE LOSS (dB)	PREAMP FACTOR (dB)	ANTENNA HEIGHT (cm)	TABLE ANGLE (Degree)	REMARK
5460	42.81	42.47	54.00	-11.19	34.85	14.60	49.11	100	355	Average
5460	51.82	51.48	74.00	-22.18	34.85	14.60	49.11	100	355	Peak
#5470	64.28	63.91	68.3	-4.02	34.86	14.62	49.11	100	355	Peak
*5510	86.49	85.92			34.91	14.78	49.12	100	355	Average
*5510	97.31	96.74			34.91	14.78	49.12	100	355	Peak
#5725	56.43	54.22	68.3	-11.87	35.17	16.18	49.14	100	355	Peak

REMARKS:

1. Emission level (dBuV/m) = Raw Value (dBuV) + Correction Factor (dB/m).
2. Correction Factor (dB/m) = Antenna Factor (dB/m) + Cable Factor (dB).
3. The other emission levels were very low against the limit.
4. Margin value = Emission level – Limit value.
5. " * ": Fundamental frequency.
6. " # ": The radiated frequency is out of the restricted band.



CHANNEL	TX Channel 110	DETECTOR FUNCTION	Peak (PK)
FREQUENCY RANGE	1GHz ~ 40GHz		Average (AV)

ANTENNA POLARITY & TEST DISTANCE: HORIZONTAL AT 3 M										
FREQ. (MHz)	EMISSION LEVEL (dBuV/m)	READ LEVEL (dBuV)	LIMIT (dBuV/m)	MARGIN (dB)	ANTENNA FACTOR (dB /m)	CABLE LOSS (dB)	PREAMP FACTOR (dB)	ANTENNA HEIGHT (cm)	TABLE ANGLE (Degree)	REMARK
5447	42.31	42.01	54.00	-11.69	34.84	14.56	49.10	100	226	Average
5447	50.80	50.50	74.00	-23.20	34.84	14.56	49.10	100	226	Peak
#5470	54.85	54.48	68.3	-13.45	34.86	14.62	49.11	100	226	Peak
*5550	85.34	84.46			34.96	15.04	49.12	100	226	Average
*5550	96.47	95.59			34.96	15.04	49.12	100	226	Peak
#5725	57.59	55.38	68.3	-10.71	35.17	16.18	49.14	100	226	Peak

ANTENNA POLARITY & TEST DISTANCE: VERTICAL AT 3 M										
FREQ. (MHz)	EMISSION LEVEL (dBuV/m)	READ LEVEL (dBuV)	LIMIT (dBuV/m)	MARGIN (dB)	ANTENNA FACTOR (dB /m)	CABLE LOSS (dB)	PREAMP FACTOR (dB)	ANTENNA HEIGHT (cm)	TABLE ANGLE (Degree)	REMARK
5447	42.47	42.17	54.00	-11.53	34.84	14.56	49.1	115	350	Average
5447	51.85	51.55	74.00	-22.15	34.84	14.56	49.1	115	350	Peak
#5470	54.53	54.16	68.3	-13.77	34.86	14.62	49.11	115	350	Peak
*5550	89.43	88.55			34.96	15.04	49.12	115	350	Average
*5550	98.60	97.72			34.96	15.04	49.12	115	350	Peak
#5725	56.77	54.56	68.3	-11.53	35.17	16.18	49.14	115	350	Peak

REMARKS:

1. Emission level (dBuV/m) = Raw Value (dBuV) + Correction Factor (dB/m).
2. Correction Factor (dB/m) = Antenna Factor (dB/m) + Cable Factor (dB).
3. The other emission levels were very low against the limit.
4. Margin value = Emission level – Limit value.
5. " * ": Fundamental frequency.
6. " # ": The radiated frequency is out of the restricted band.



CHANNEL	TX Channel 134	DETECTOR FUNCTION	Peak (PK)
FREQUENCY RANGE	1GHz ~ 40GHz		Average (AV)

ANTENNA POLARITY & TEST DISTANCE: HORIZONTAL AT 3 M										
FREQ. (MHz)	EMISSION LEVEL (dBuV/m)	READ LEVEL (dBuV)	LIMIT (dBuV/m)	MARGIN (dB)	ANTENNA FACTOR (dB /m)	CABLE LOSS (dB)	PREAMP FACTOR (dB)	ANTENNA HEIGHT (cm)	TABLE ANGLE (Degree)	REMARK
5460	42.17	41.83	54.00	-11.83	34.85	14.60	49.11	106	232	Average
5460	50.59	50.25	74.00	-23.41	34.85	14.60	49.11	106	232	Peak
#5470	53.72	53.35	68.3	-14.58	34.86	14.62	49.11	106	232	Peak
*5670	91.68	89.90			35.10	15.82	49.14	106	232	Average
*5670	100.42	98.64			35.10	15.82	49.14	106	232	Peak
#5725	61.59	59.38	68.3	-6.71	35.17	16.18	49.14	106	232	Peak

ANTENNA POLARITY & TEST DISTANCE: VERTICAL AT 3 M										
FREQ. (MHz)	EMISSION LEVEL (dBuV/m)	READ LEVEL (dBuV)	LIMIT (dBuV/m)	MARGIN (dB)	ANTENNA FACTOR (dB /m)	CABLE LOSS (dB)	PREAMP FACTOR (dB)	ANTENNA HEIGHT (cm)	TABLE ANGLE (Degree)	REMARK
5400	42.19	42.08	54.00	-11.81	34.78	14.42	49.09	100	352	Average
5400	52.37	52.26	74.00	-21.63	34.78	14.42	49.09	100	352	Peak
#5470	54.88	54.51	68.3	-13.42	34.86	14.62	49.11	100	352	Peak
*5670	92.21	90.43			35.10	15.82	49.14	100	352	Average
*5670	102.17	100.39			35.10	15.82	49.14	100	352	Peak
#5725	62.59	60.38	68.3	-5.71	35.17	16.18	49.14	100	352	Peak

REMARKS:

1. Emission level (dBuV/m) = Raw Value (dBuV) + Correction Factor (dB/m).
2. Correction Factor (dB/m) = Antenna Factor (dB/m) + Cable Factor (dB).
3. The other emission levels were very low against the limit.
4. Margin value = Emission level – Limit value.
5. " * ": Fundamental frequency.
6. " # ": The radiated frequency is out of the restricted band.



ABOVE 1GHz WORST-CASE DATA: Band 4

802.11a

CHANNEL	TX Channel 149	DETECTOR FUNCTION	Peak (PK)
FREQUENCY RANGE	1GHz ~ 40GHz		Average (AV)

ANTENNA POLARITY & TEST DISTANCE: HORIZONTAL AT 3 M										
FREQ. (MHz)	EMISSION LEVEL (dBuV/m)	READ LEVEL (dBuV)	LIMIT (dBuV/m)	MARGIN (dB)	ANTENNA FACTOR (dB /m)	CABLE LOSS (dB)	PREAMP FACTOR (dB)	ANTENNA HEIGHT (cm)	TABLE ANGLE (Degree)	REMARK
*5745	93.70	91.34			35.19	16.31	49.14	100	228	Average
*5745	102.59	100.23			35.19	16.31	49.14	100	228	Peak
11490	46.90	36.88	54.00	-7.10	39.10	19.08	48.16	100	228	Average
11490	60.94	50.92	74.00	-13.06	39.10	19.08	48.16	100	228	Peak
ANTENNA POLARITY & TEST DISTANCE: VERTICAL AT 3 M										
FREQ. (MHz)	EMISSION LEVEL (dBuV/m)	READ LEVEL (dBuV)	LIMIT (dBuV/m)	MARGIN (dB)	ANTENNA FACTOR (dB /m)	CABLE LOSS (dB)	PREAMP FACTOR (dB)	ANTENNA HEIGHT (cm)	TABLE ANGLE (Degree)	REMARK
*5745	98.68	96.32			35.19	16.31	49.14	100	355	Average
*5745	106.95	104.59			35.19	16.31	49.14	100	355	Peak
11490	47.50	37.48	54.00	-6.50	39.10	19.08	48.16	100	355	Average
11490	61.38	51.36	74.00	-12.62	39.10	19.08	48.16	100	355	Peak

REMARKS:

1. Emission level (dBuV/m) = Raw Value (dBuV) + Correction Factor (dB/m).
2. Correction Factor (dB/m) = Antenna Factor (dB/m) + Cable Factor (dB).
3. The other emission levels were very low against the limit.
4. Margin value = Emission level – Limit value.
5. " * ": Fundamental frequency.



Oobe Data

802.11a

ANTENNA POLARITY & TEST DISTANCE: HORIZONTAL AT 3 M										
FREQ. (MHz)	EMISSION LEVEL (dBuV/m)	READ LEVEL (dBuV)	LIMIT (dBuV/m)	MARGIN (dB)	ANTENNA FACTOR (dB /m)	CABLE LOSS (dB)	PREAMP FACTOR (dB)	ANTENNA HEIGHT (cm)	TABLE ANGLE (Degree)	REMARK
5663.05	54.6	52.87	77.99	-23.39	35.1	15.77	49.14	101	230	Peak
5908.15	55.16	51.56	80.73	-25.57	35.39	17.37	49.16	101	230	Peak
ANTENNA POLARITY & TEST DISTANCE: VERTICAL AT 3 M										
FREQ. (MHz)	EMISSION LEVEL (dBuV/m)	READ LEVEL (dBuV)	LIMIT (dBuV/m)	MARGIN (dB)	ANTENNA FACTOR (dB /m)	CABLE LOSS (dB)	PREAMP FACTOR (dB)	ANTENNA HEIGHT (cm)	TABLE ANGLE (Degree)	REMARK
5654.03	55.26	53.61	71.29	-16.03	35.08	15.71	49.14	101	355	Peak
5917.65	56.28	52.61	73.72	-17.44	35.4	17.43	49.16	101	355	Peak

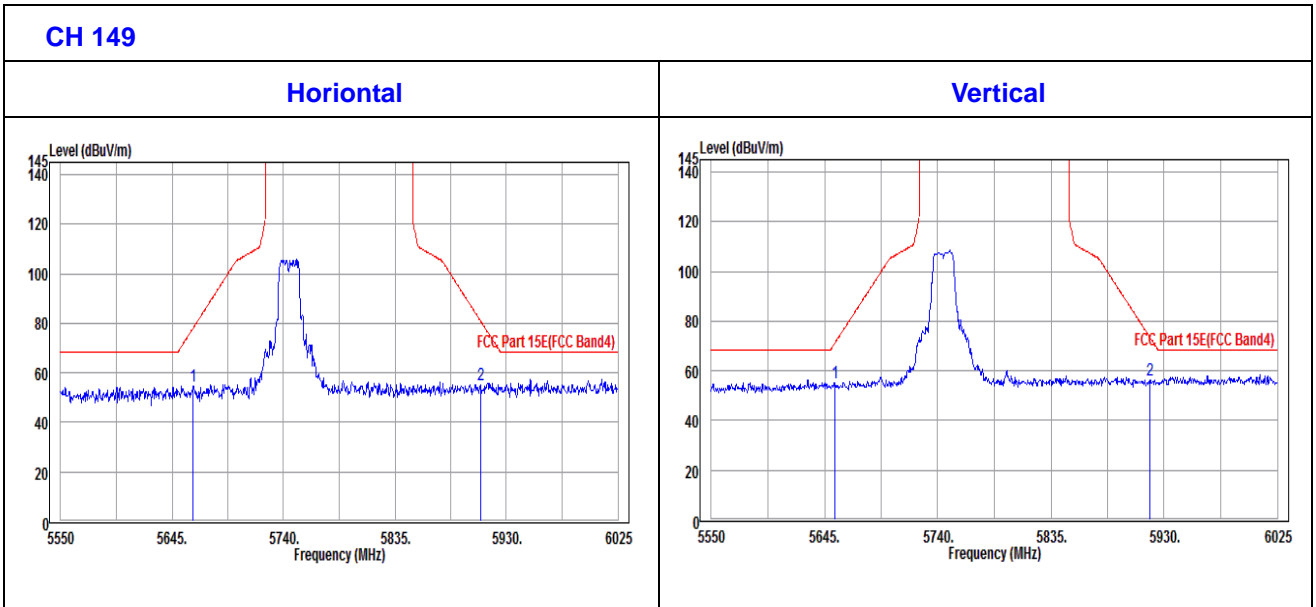



CHANNEL	TX Channel 157	DETECTOR FUNCTION	Peak (PK)
FREQUENCY RANGE	1GHz ~ 40GHz		Average (AV)

ANTENNA POLARITY & TEST DISTANCE: HORIZONTAL AT 3 M										
FREQ. (MHz)	EMISSION LEVEL (dBuV/m)	READ LEVEL (dBuV)	LIMIT (dBuV/m)	MARGIN (dB)	ANTENNA FACTOR (dB /m)	CABLE LOSS (dB)	PREAMP FACTOR (dB)	ANTENNA HEIGHT (cm)	TABLE ANGLE (Degree)	REMARK
*5785	93.99	91.33			35.24	16.57	49.15	100	230	Average
*5785	103.03	100.37			35.24	16.57	49.15	100	230	Peak
11570	47.37	37.26	54.00	-6.63	39.16	19.12	48.17	100	230	Average
11570	61.33	51.22	74.00	-12.67	39.16	19.12	48.17	100	230	Peak
ANTENNA POLARITY & TEST DISTANCE: VERTICAL AT 3 M										
FREQ. (MHz)	EMISSION LEVEL (dBuV/m)	READ LEVEL (dBuV)	LIMIT (dBuV/m)	MARGIN (dB)	ANTENNA FACTOR (dB /m)	CABLE LOSS (dB)	PREAMP FACTOR (dB)	ANTENNA HEIGHT (cm)	TABLE ANGLE (Degree)	REMARK
*5785	98.05	95.39			35.24	16.57	49.15	100	348	Average
*5785	106.38	103.72			35.24	16.57	49.15	100	348	Peak
11570	46.69	36.58	54.00	-7.31	39.16	19.12	48.17	100	348	Average
11570	61.03	50.92	74.00	-12.97	39.16	19.12	48.17	100	348	Peak

REMARKS:

1. Emission level (dBuV/m) = Raw Value (dBuV) + Correction Factor (dB/m).
2. Correction Factor (dB/m) = Antenna Factor (dB/m) + Cable Factor (dB).
3. The other emission levels were very low against the limit.
4. Margin value = Emission level – Limit value.
5. " * ": Fundamental frequency.



Oobe Data

802.11a

ANTENNA POLARITY & TEST DISTANCE: HORIZONTAL AT 3 M										
FREQ. (MHz)	EMISSION LEVEL (dBuV/m)	READ LEVEL (dBuV)	LIMIT (dBuV/m)	MARGIN (dB)	ANTENNA FACTOR (dB /m)	CABLE LOSS (dB)	PREAMP FACTOR (dB)	ANTENNA HEIGHT (cm)	TABLE ANGLE (Degree)	REMARK
5661.63	55.23	53.52	76.93	-21.7	35.09	15.76	49.14	101	230	Peak
5904.83	55.7	52.12	83.19	-27.49	35.39	17.35	49.16	101	230	Peak
ANTENNA POLARITY & TEST DISTANCE: VERTICAL AT 3 M										
FREQ. (MHz)	EMISSION LEVEL (dBuV/m)	READ LEVEL (dBuV)	LIMIT (dBuV/m)	MARGIN (dB)	ANTENNA FACTOR (dB /m)	CABLE LOSS (dB)	PREAMP FACTOR (dB)	ANTENNA HEIGHT (cm)	TABLE ANGLE (Degree)	REMARK
5661.63	54.76	53.05	76.93	-22.17	35.09	15.76	49.14	101	355	Peak
5913.85	55.94	52.29	76.52	-20.58	35.4	17.41	49.16	101	355	Peak

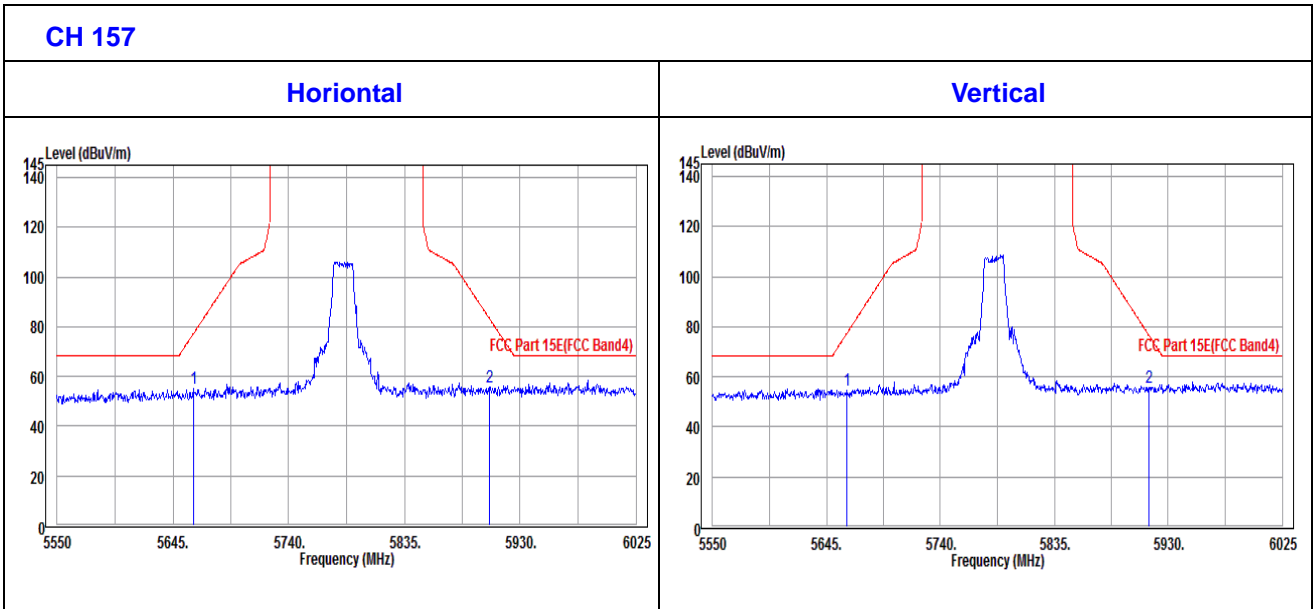



CHANNEL	TX Channel 161	DETECTOR FUNCTION	Peak (PK)
FREQUENCY RANGE	1GHz ~ 40GHz		Average (AV)

ANTENNA POLARITY & TEST DISTANCE: HORIZONTAL AT 3 M										
FREQ. (MHz)	EMISSION LEVEL (dBuV/m)	READ LEVEL (dBuV)	LIMIT (dBuV/m)	MARGIN (dB)	ANTENNA FACTOR (dB /m)	CABLE LOSS (dB)	PREAMP FACTOR (dB)	ANTENNA HEIGHT (cm)	TABLE ANGLE (Degree)	REMARK
*5805	96.39	93.57			35.27	16.7	49.15	105	230	Average
*5805	105.57	102.75			35.27	16.7	49.15	105	230	Peak
11610	47.21	37.06	54.00	-6.79	39.19	19.14	48.18	105	230	Average
11610	61.29	51.14	74.00	-12.71	39.19	19.14	48.18	105	230	Peak
ANTENNA POLARITY & TEST DISTANCE: VERTICAL AT 3 M										
FREQ. (MHz)	EMISSION LEVEL (dBuV/m)	READ LEVEL (dBuV)	LIMIT (dBuV/m)	MARGIN (dB)	ANTENNA FACTOR (dB /m)	CABLE LOSS (dB)	PREAMP FACTOR (dB)	ANTENNA HEIGHT (cm)	TABLE ANGLE (Degree)	REMARK
*5805	97.79	94.97			35.27	16.7	49.15	100	344	Average
*5805	106.32	103.5			35.27	16.7	49.15	100	344	Peak
11610	46.62	36.47	54.00	-7.38	39.19	19.14	48.18	100	344	Average
11610	60.89	50.74	74.00	-13.11	39.19	19.14	48.18	100	344	Peak

REMARKS:

1. Emission level (dBuV/m) = Raw Value (dBuV) + Correction Factor (dB/m).
2. Correction Factor (dB/m) = Antenna Factor (dB/m) + Cable Factor (dB).
3. The other emission levels were very low against the limit.
4. Margin value = Emission level – Limit value.
5. " * ": Fundamental frequency.



Oobe Data

802.11a

ANTENNA POLARITY & TEST DISTANCE: HORIZONTAL AT 3 M										
FREQ. (MHz)	EMISSION LEVEL (dBuV/m)	READ LEVEL (dBuV)	LIMIT (dBuV/m)	MARGIN (dB)	ANTENNA FACTOR (dB /m)	CABLE LOSS (dB)	PREAMP FACTOR (dB)	ANTENNA HEIGHT (cm)	TABLE ANGLE (Degree)	REMARK
5669.23	54.83	53.06	82.57	-27.74	35.1	15.81	49.14	101	225	Peak
5910.05	56.67	53.06	79.33	-22.66	35.39	17.38	49.16	101	225	Peak
ANTENNA POLARITY & TEST DISTANCE: VERTICAL AT 3 M										
FREQ. (MHz)	EMISSION LEVEL (dBuV/m)	READ LEVEL (dBuV)	LIMIT (dBuV/m)	MARGIN (dB)	ANTENNA FACTOR (dB /m)	CABLE LOSS (dB)	PREAMP FACTOR (dB)	ANTENNA HEIGHT (cm)	TABLE ANGLE (Degree)	REMARK
5659.25	54.05	52.35	75.17	-21.12	35.09	15.75	49.14	101	355	Peak
5906.25	56.01	52.42	82.14	-26.13	35.39	17.36	49.16	101	355	Peak

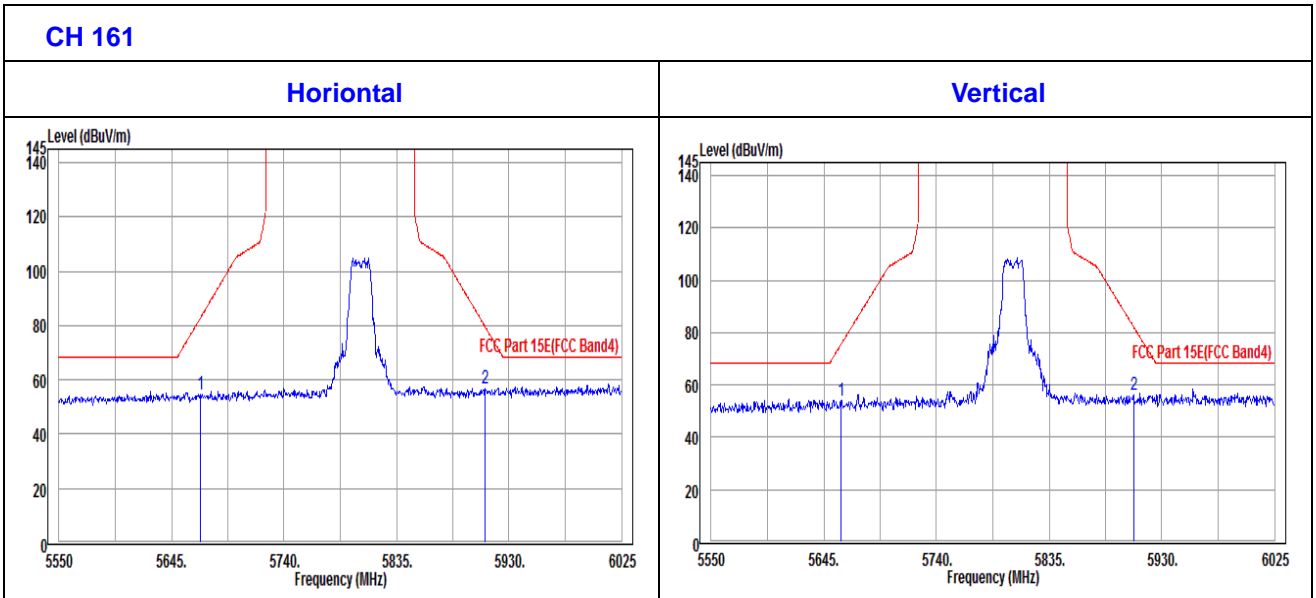



802.11n (20MHz)

CHANNEL	TX Channel 149	DETECTOR FUNCTION	Peak (PK)
FREQUENCY RANGE	1GHz ~ 40GHz		Average (AV)

ANTENNA POLARITY & TEST DISTANCE: HORIZONTAL AT 3 M										
FREQ. (MHz)	EMISSION LEVEL (dBuV/m)	READ LEVEL (dBuV)	LIMIT (dBuV/m)	MARGIN (dB)	ANTENNA FACTOR (dB /m)	CABLE LOSS (dB)	PREAMP FACTOR (dB)	ANTENNA HEIGHT (cm)	TABLE ANGLE (Degree)	REMARK
*5745	94.95	92.59			35.19	16.31	49.14	108	231	Average
*5745	103.42	101.06			35.19	16.31	49.14	108	231	Peak
11490	46.49	36.47	54.00	-7.51	39.1	19.08	48.16	108	231	Average
11490	60.38	50.36	74.00	-13.62	39.1	19.08	48.16	108	231	Peak
ANTENNA POLARITY & TEST DISTANCE: VERTICAL AT 3 M										
FREQ. (MHz)	EMISSION LEVEL (dBuV/m)	READ LEVEL (dBuV)	LIMIT (dBuV/m)	MARGIN (dB)	ANTENNA FACTOR (dB /m)	CABLE LOSS (dB)	PREAMP FACTOR (dB)	ANTENNA HEIGHT (cm)	TABLE ANGLE (Degree)	REMARK
*5745	97.65	95.29			35.19	16.31	49.14	110	352	Average
*5745	104.83	102.47			35.19	16.31	49.14	110	352	Peak
11490	46.35	36.33	54.00	-7.65	39.1	19.08	48.16	110	352	Average
11490	60.66	50.64	74.00	-13.34	39.1	19.08	48.16	110	352	Peak

REMARKS:

1. Emission level (dBuV/m) = Raw Value (dBuV) + Correction Factor (dB/m).
2. Correction Factor (dB/m) = Antenna Factor (dB/m) + Cable Factor (dB).
3. The other emission levels were very low against the limit.
4. Margin value = Emission level – Limit value.
5. " * ": Fundamental frequency.



OOBE DATA

802.11n (20MHZ)

ANTENNA POLARITY & TEST DISTANCE: HORIZONTAL AT 3 M											
FREQ. (MHz)	EMISSION LEVEL (dBuV/m)	READ LEVEL (dBuV)	LIMIT (dBuV/m)	MARGIN (dB)	ANTENNA FACTOR (dB /m)	CABLE LOSS (dB)	PREAMP FACTOR (dB)	ANTENNA HEIGHT (cm)	TABLE ANGLE (Degree)	REMARK	
5666.85	55.55	53.79	80.81	-25.26	35.1	15.8	49.14	101	225	Peak	
5915.28	56.09	52.43	75.47	-19.38	35.4	17.42	49.16	101	225	Peak	
ANTENNA POLARITY & TEST DISTANCE: VERTICAL AT 3 M											
FREQ. (MHz)	EMISSION LEVEL (dBuV/m)	READ LEVEL (dBuV)	LIMIT (dBuV/m)	MARGIN (dB)	ANTENNA FACTOR (dB /m)	CABLE LOSS (dB)	PREAMP FACTOR (dB)	ANTENNA HEIGHT (cm)	TABLE ANGLE (Degree)	REMARK	
5655.93	55	53.32	72.7	-17.7	35.09	15.73	49.14	101	350	Peak	
5906.73	56.24	52.65	81.79	-25.55	35.39	17.36	49.16	101	350	Peak	

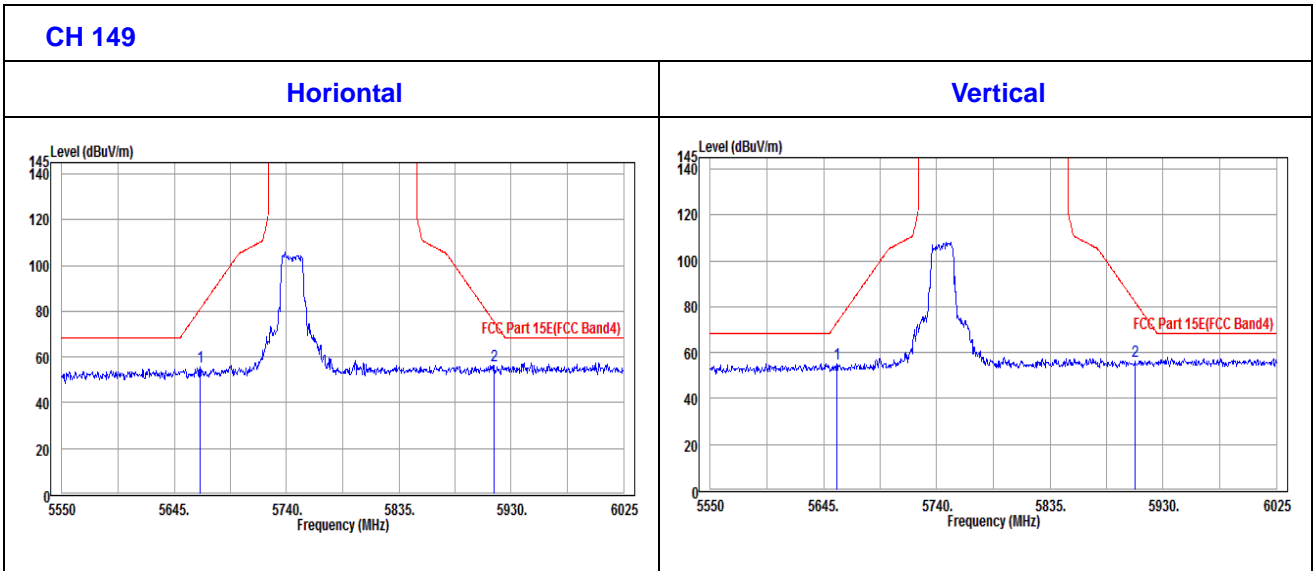



CHANNEL	TX Channel 157	DETECTOR FUNCTION	Peak (PK)
FREQUENCY RANGE	1GHz ~ 40GHz		Average (AV)

ANTENNA POLARITY & TEST DISTANCE: HORIZONTAL AT 3 M										
FREQ. (MHz)	EMISSION LEVEL (dBuV/m)	READ LEVEL (dBuV)	LIMIT (dBuV/m)	MARGIN (dB)	ANTENNA FACTOR (dB /m)	CABLE LOSS (dB)	PREAMP FACTOR (dB)	ANTENNA HEIGHT (cm)	TABLE ANGLE (Degree)	REMARK
*5785	97.21	94.55			35.24	16.57	49.15	108	234	Average
*5785	105.64	102.98			35.24	16.57	49.15	108	234	Peak
11570	47.02	36.91	54.00	-6.98	39.16	19.12	48.17	108	234	Average
11570	60.47	50.36	74.00	-13.53	39.16	19.12	48.17	108	234	Peak
ANTENNA POLARITY & TEST DISTANCE: VERTICAL AT 3 M										
FREQ. (MHz)	EMISSION LEVEL (dBuV/m)	READ LEVEL (dBuV)	LIMIT (dBuV/m)	MARGIN (dB)	ANTENNA FACTOR (dB /m)	CABLE LOSS (dB)	PREAMP FACTOR (dB)	ANTENNA HEIGHT (cm)	TABLE ANGLE (Degree)	REMARK
*5785	99.59	96.93			35.24	16.57	49.15	100	349	Average
*5785	107.92	105.26			35.24	16.57	49.15	100	349	Peak
11570	46.73	36.62	54.00	-7.27	39.16	19.12	48.17	100	349	Average
11570	60.84	50.73	74.00	-13.16	39.16	19.12	48.17	100	349	Peak

REMARKS:

1. Emission level (dBuV/m) = Raw Value (dBuV) + Correction Factor (dB/m).
2. Correction Factor (dB/m) = Antenna Factor (dB/m) + Cable Factor (dB).
3. The other emission levels were very low against the limit.
4. Margin value = Emission level – Limit value.
5. " * ": Fundamental frequency.



Oobe Data

802.11n (20MHz)

ANTENNA POLARITY & TEST DISTANCE: HORIZONTAL AT 3 M										
FREQ. (MHz)	EMISSION LEVEL (dBuV/m)	READ LEVEL (dBuV)	LIMIT (dBuV/m)	MARGIN (dB)	ANTENNA FACTOR (dB /m)	CABLE LOSS (dB)	PREAMP FACTOR (dB)	ANTENNA HEIGHT (cm)	TABLE ANGLE (Degree)	REMARK
5660.68	55.27	53.56	76.23	-20.96	35.09	15.76	49.14	101	224	Peak
5907.68	57.23	53.63	81.09	-23.86	35.39	17.37	49.16	101	224	Peak
ANTENNA POLARITY & TEST DISTANCE: VERTICAL AT 3 M										
FREQ. (MHz)	EMISSION LEVEL (dBuV/m)	READ LEVEL (dBuV)	LIMIT (dBuV/m)	MARGIN (dB)	ANTENNA FACTOR (dB /m)	CABLE LOSS (dB)	PREAMP FACTOR (dB)	ANTENNA HEIGHT (cm)	TABLE ANGLE (Degree)	REMARK
5659.7	53.2	51.5	75.52	-22.32	35.09	15.75	49.14	101	350	Peak
5911	55.11	51.49	78.63	-23.52	35.39	17.39	49.16	101	350	Peak

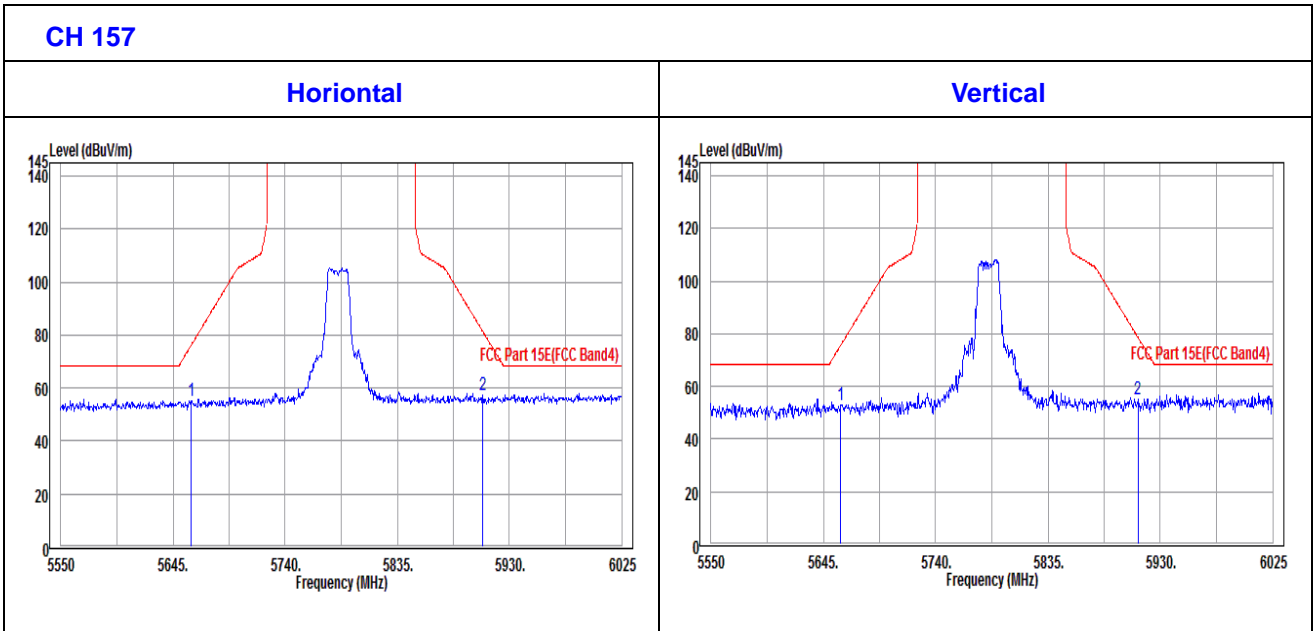



CHANNEL	TX Channel 161	DETECTOR FUNCTION	Peak (PK)
FREQUENCY RANGE	1GHz ~ 40GHz		Average (AV)

ANTENNA POLARITY & TEST DISTANCE: HORIZONTAL AT 3 M										
FREQ. (MHz)	EMISSION LEVEL (dBuV/m)	READ LEVEL (dBuV)	LIMIT (dBuV/m)	MARGIN (dB)	ANTENNA FACTOR (dB /m)	CABLE LOSS (dB)	PREAMP FACTOR (dB)	ANTENNA HEIGHT (cm)	TABLE ANGLE (Degree)	REMARK
*5805	96.3	93.48			35.27	16.70	49.15	110	236	Average
*5805	105.19	102.37			35.27	16.70	49.15	110	236	Peak
11610	47.27	37.12	54.00	-6.73	39.19	19.14	48.18	110	236	Average
11610	61.21	51.06	74.00	-12.79	39.19	19.14	48.18	110	236	Peak
ANTENNA POLARITY & TEST DISTANCE: VERTICAL AT 3 M										
FREQ. (MHz)	EMISSION LEVEL (dBuV/m)	READ LEVEL (dBuV)	LIMIT (dBuV/m)	MARGIN (dB)	ANTENNA FACTOR (dB /m)	CABLE LOSS (dB)	PREAMP FACTOR (dB)	ANTENNA HEIGHT (cm)	TABLE ANGLE (Degree)	REMARK
*5805	99.48	96.66			35.27	16.70	49.15	100	356	Average
*5805	108.19	105.37			35.27	16.70	49.15	100	356	Peak
11610	47.18	37.03	54.00	-6.82	39.19	19.14	48.18	100	356	Average
11610	60.73	50.58	74.00	-13.27	39.19	19.14	48.18	100	356	Peak

REMARKS:

1. Emission level (dBuV/m) = Raw Value (dBuV) + Correction Factor (dB/m).
2. Correction Factor (dB/m) = Antenna Factor (dB/m) + Cable Factor (dB).
3. The other emission levels were very low against the limit.
4. Margin value = Emission level – Limit value.
5. " * ": Fundamental frequency.



OOBE DATA

802.11n (20MHZ)

ANTENNA POLARITY & TEST DISTANCE: HORIZONTAL AT 3 M										
FREQ. (MHz)	EMISSION LEVEL (dBuV/m)	READ LEVEL (dBuV)	LIMIT (dBuV/m)	MARGIN (dB)	ANTENNA FACTOR (dB /m)	CABLE LOSS (dB)	PREAMP FACTOR (dB)	ANTENNA HEIGHT (cm)	TABLE ANGLE (Degree)	REMARK
5666.38	54.92	53.17	80.45	-25.53	35.1	15.79	49.14	101	224	Peak
5905.78	54.88	51.29	82.49	-27.61	35.39	17.36	49.16	101	224	Peak
ANTENNA POLARITY & TEST DISTANCE: VERTICAL AT 3 M										
FREQ. (MHz)	EMISSION LEVEL (dBuV/m)	READ LEVEL (dBuV)	LIMIT (dBuV/m)	MARGIN (dB)	ANTENNA FACTOR (dB /m)	CABLE LOSS (dB)	PREAMP FACTOR (dB)	ANTENNA HEIGHT (cm)	TABLE ANGLE (Degree)	REMARK
5661.15	55.42	53.71	76.58	-21.16	35.09	15.76	49.14	101	298	Peak
5911.48	56.44	52.82	78.28	-21.84	35.39	17.39	49.16	101	298	Peak

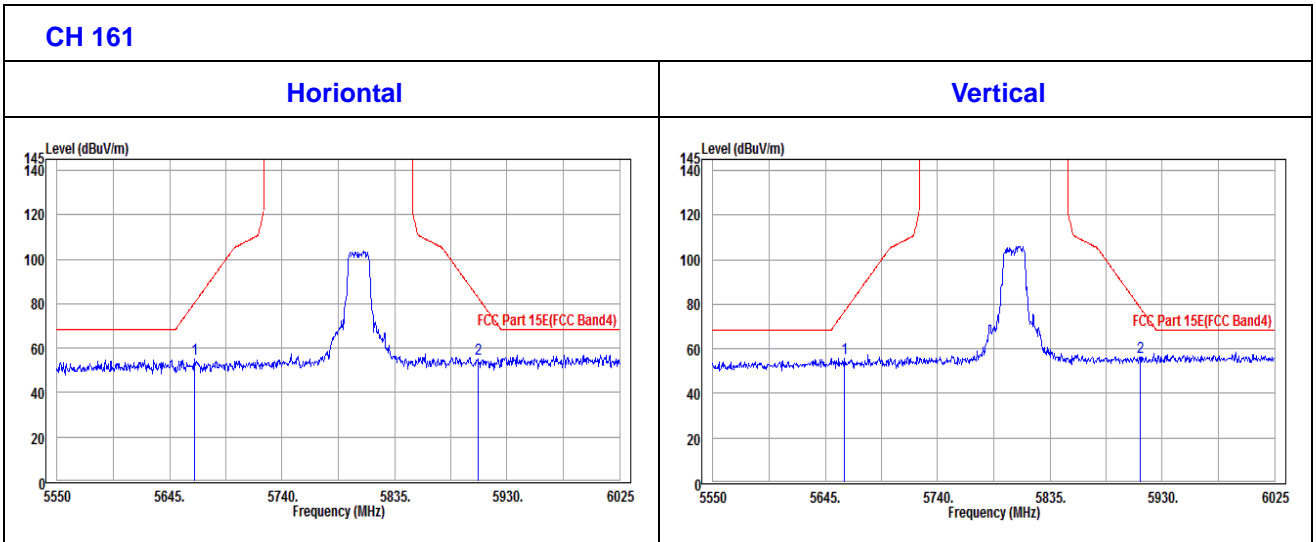



802.11n (40MHz)

CHANNEL	TX Channel 151	DETECTOR FUNCTION	Peak (PK)
FREQUENCY RANGE	1GHz ~ 40GHz		Average (AV)

ANTENNA POLARITY & TEST DISTANCE: HORIZONTAL AT 3 M										
FREQ. (MHz)	EMISSION LEVEL (dBuV/m)	READ LEVEL (dBuV)	LIMIT (dBuV/m)	MARGIN (dB)	ANTENNA FACTOR (dB /m)	CABLE LOSS (dB)	PREAMP FACTOR (dB)	ANTENNA HEIGHT (cm)	TABLE ANGLE (Degree)	REMARK
*5755	90.97	88.54			35.21	16.37	49.15	105	228	Average
*5755	100.44	98.01			35.21	16.37	49.15	105	228	Peak
11510	46.99	36.95	54.00	-7.01	39.11	19.09	48.16	105	228	Average
11510	60.87	50.83	74.00	-13.13	39.11	19.09	48.16	105	228	Peak
ANTENNA POLARITY & TEST DISTANCE: VERTICAL AT 3 M										
FREQ. (MHz)	EMISSION LEVEL (dBuV/m)	READ LEVEL (dBuV)	LIMIT (dBuV/m)	MARGIN (dB)	ANTENNA FACTOR (dB /m)	CABLE LOSS (dB)	PREAMP FACTOR (dB)	ANTENNA HEIGHT (cm)	TABLE ANGLE (Degree)	REMARK
*5755	93.46	91.03			35.21	16.37	49.15	110	350	Average
*5755	102.12	99.69			35.21	16.37	49.15	110	350	Peak
11510	46.82	36.78	54.00	-7.18	39.11	19.09	48.16	110	350	Average
11510	61.36	51.32	74.00	-12.64	39.11	19.09	48.16	110	350	Peak

REMARKS:

1. Emission level (dBuV/m) = Raw Value (dBuV) + Correction Factor (dB/m).
2. Correction Factor (dB/m) = Antenna Factor (dB/m) + Cable Factor (dB).
3. The other emission levels were very low against the limit.
4. Margin value = Emission level – Limit value.
5. " * ": Fundamental frequency.



**BUREAU
VERITAS**

Test Report No.: RF160524W004-6

Oobe Data

802.11n (40MHz)

ANTENNA POLARITY & TEST DISTANCE: HORIZONTAL AT 3 M										
FREQ. (MHz)	EMISSION LEVEL (dBuV/m)	READ LEVEL (dBuV)	LIMIT (dBuV/m)	MARGIN (dB)	ANTENNA FACTOR (dB /m)	CABLE LOSS (dB)	PREAMP FACTOR (dB)	ANTENNA HEIGHT (cm)	TABLE ANGLE (Degree)	REMARK
5664	55.65	53.91	78.69	-23.04	35.1	15.78	49.14	101	234	Peak
5908.6	56.1	52.5	80.38	-24.28	35.39	17.37	49.16	101	234	Peak
ANTENNA POLARITY & TEST DISTANCE: VERTICAL AT 3 M										
FREQ. (MHz)	EMISSION LEVEL (dBuV/m)	READ LEVEL (dBuV)	LIMIT (dBuV/m)	MARGIN (dB)	ANTENNA FACTOR (dB /m)	CABLE LOSS (dB)	PREAMP FACTOR (dB)	ANTENNA HEIGHT (cm)	TABLE ANGLE (Degree)	REMARK
5661.6	54.56	52.85	76.93	-22.37	35.09	15.76	49.14	101	348	Peak
5911.95	55.95	52.32	77.93	-21.98	35.39	17.4	49.16	101	348	Peak

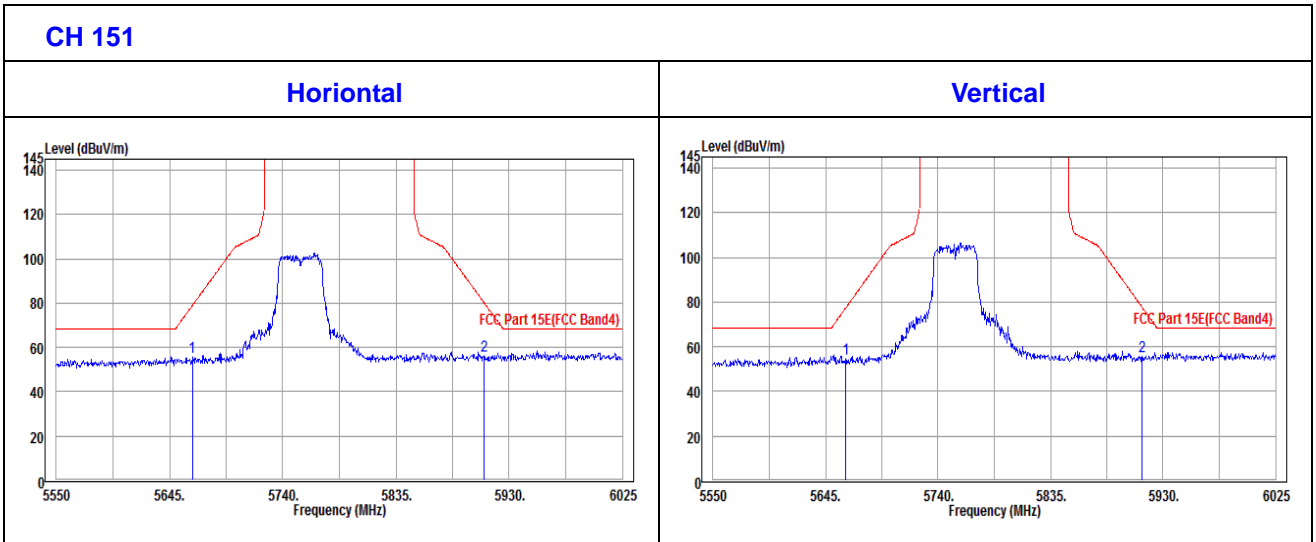



CHANNEL	TX Channel 159	DETECTOR FUNCTION	Peak (PK)
FREQUENCY RANGE	1GHz ~ 40GHz		Average (AV)

ANTENNA POLARITY & TEST DISTANCE: HORIZONTAL AT 3 M										
FREQ. (MHz)	EMISSION LEVEL (dBuV/m)	READ LEVEL (dBuV)	LIMIT (dBuV/m)	MARGIN (dB)	ANTENNA FACTOR (dB /m)	CABLE LOSS (dB)	PREAMP FACTOR (dB)	ANTENNA HEIGHT (cm)	TABLE ANGLE (Degree)	REMARK
*5795	92.99	90.26			35.25	16.63	49.15	108	234	Average
*5795	102.77	100.04			35.25	16.63	49.15	108	234	Peak
11590	47.01	36.88	54.00	-6.99	39.17	19.13	48.17	108	234	Average
11590	61.37	51.24	74.00	-12.63	39.17	19.13	48.17	108	234	Peak
ANTENNA POLARITY & TEST DISTANCE: VERTICAL AT 3 M										
FREQ. (MHz)	EMISSION LEVEL (dBuV/m)	READ LEVEL (dBuV)	LIMIT (dBuV/m)	MARGIN (dB)	ANTENNA FACTOR (dB /m)	CABLE LOSS (dB)	PREAMP FACTOR (dB)	ANTENNA HEIGHT (cm)	TABLE ANGLE (Degree)	REMARK
*5795	95.62	92.89			35.25	16.63	49.15	105	350	Average
*5795	104.43	101.7			35.25	16.63	49.15	105	350	Peak
11590	47.15	37.02	54.00	-6.85	39.17	19.13	48.17	105	350	Average
11590	62.02	51.89	74.00	-11.98	39.17	19.13	48.17	105	350	Peak

REMARKS:

1. Emission level (dBuV/m) = Raw Value (dBuV) + Correction Factor (dB/m).
2. Correction Factor (dB/m) = Antenna Factor (dB/m) + Cable Factor (dB).
3. The other emission levels were very low against the limit.
4. Margin value = Emission level – Limit value.
5. " * ": Fundamental frequency.



Oobe Data

802.11n (40MHz)

ANTENNA POLARITY & TEST DISTANCE: HORIZONTAL AT 3 M										
FREQ. (MHz)	EMISSION LEVEL (dBuV/m)	READ LEVEL (dBuV)	LIMIT (dBuV/m)	MARGIN (dB)	ANTENNA FACTOR (dB /m)	CABLE LOSS (dB)	PREAMP FACTOR (dB)	ANTENNA HEIGHT (cm)	TABLE ANGLE (Degree)	REMARK
5658.3	54.08	52.39	74.46	-20.38	35.09	15.74	49.14	101	225	Peak
5909.6	57.18	53.57	79.68	-22.5	35.39	17.38	49.16	101	225	Peak
ANTENNA POLARITY & TEST DISTANCE: VERTICAL AT 3 M										
FREQ. (MHz)	EMISSION LEVEL (dBuV/m)	READ LEVEL (dBuV)	LIMIT (dBuV/m)	MARGIN (dB)	ANTENNA FACTOR (dB /m)	CABLE LOSS (dB)	PREAMP FACTOR (dB)	ANTENNA HEIGHT (cm)	TABLE ANGLE (Degree)	REMARK
5654.9	55.58	53.91	72	-16.42	35.09	15.72	49.14	101	350	Peak
5902.9	57.84	54.28	84.6	-26.76	35.38	17.34	49.16	101	350	Peak

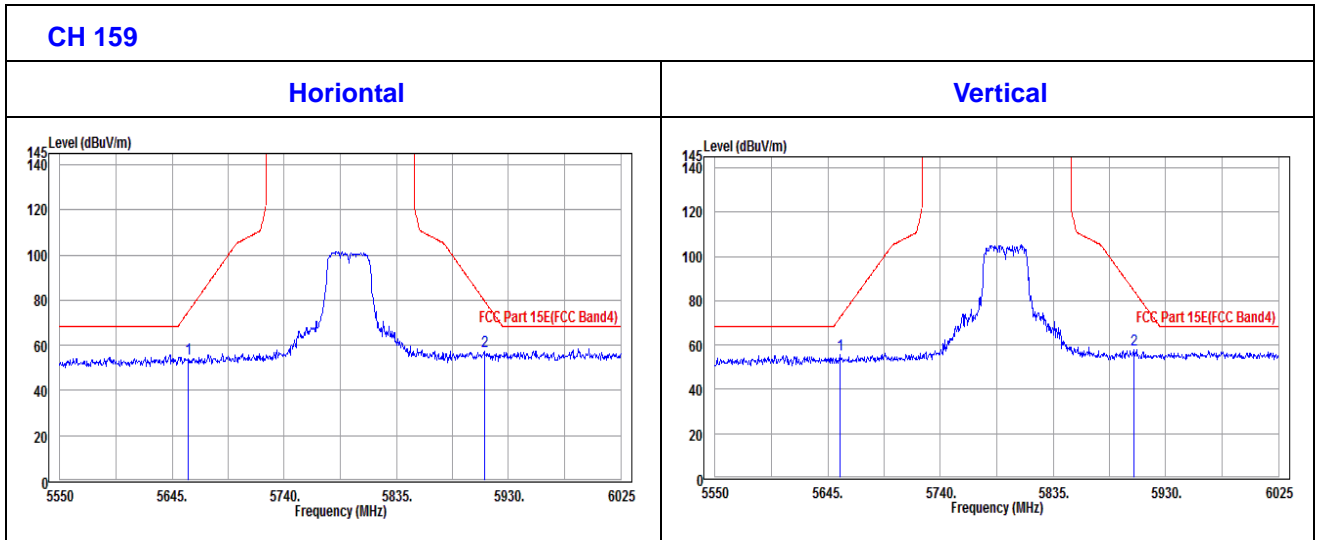



4.2 CONDUCTED EMISSION MEASUREMENT

4.2.1 LIMITS OF CONDUCTED EMISSION MEASUREMENT

FREQUENCY OF EMISSION (MHz)	CONDUCTED LIMIT (dBµV)	
	Quasi-peak	Average
0.15 ~ 0.5	66 to 56	56 to 46
0.5 ~ 5	56	46
5 ~ 30	60	50

NOTE: 1. The lower limit shall apply at the transition frequencies.

2. The limit decreases in line with the logarithm of the frequency in the range of 0.15 to 0.50MHz.

3. All emanations from a class A/B digital device or system, including any network of conductors and apparatus connected thereto, shall not exceed the level of field strengths specified above.

4.2.2 TEST INSTRUMENTS

Equipment	Manufacturer	Model No.	Serial No.	Last Cal.	Next Cal.
EMI Test Receiver	Rohde&Schwarz	ESCS30	100340	May 11,15	May 10,17
Artificial Mains Network	Rohde&Schwarz	ENV216	101173	Mar. 04,16	Mar. 03,17
Artificial Mains Network	Rohde&Schwarz	ESH3-Z5	100317	Apr. 05,16	Apr. 04,17
Voltage probe	SCHWARZBECK	TK 9421	TK 9421-176	Jan. 08,16	Jan. 07,17
Test software	ADT	ADT_Cond_V7.3.7	N/A	N/A	N/A

NOTE:

1. The test was performed in shielded room 553.

2. The calibration interval of the above test instruments is 12 months. And the calibrations are traceable to CEPREI/CHINA, GRGT/CHINA and NIM/CHINA.

4.2.3 TEST PROCEDURES

- a. The EUT was placed 0.4 meters from the conducting wall of the shielded room with EUT being connected to the power mains through a line impedance stabilization network (LISN). Other support units were connected to the power mains through another LISN. The two LISNs provide 50 ohm/ 50uH of coupling impedance for the measuring instrument.
- b. Both lines of the power mains connected to the EUT were checked for maximum conducted interference.
- c. The frequency range from 150kHz to 30MHz was searched. Emission levels under (Limit - 20dB) was not recorded.

NOTE: All modes of operation were investigated and the worst-case emissions are reported.



4.2.4 DEVIATION FROM TEST STANDARD

No deviation.

4.2.5 TEST SETUP

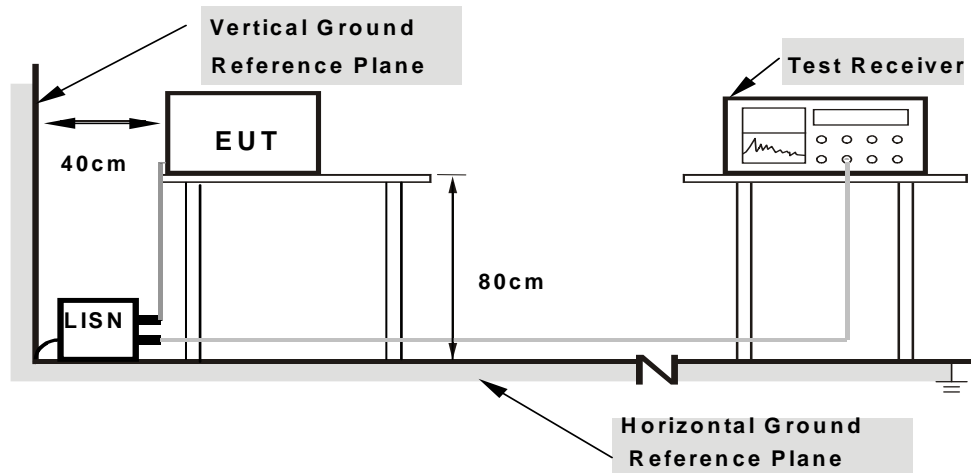

- Note: 1.Support units were connected to second LISN.
2.Both of LISNs (AMN) are 80 cm from EUT and at least 80
from other units and other metal planes**

For the actual test configuration, please refer to the attached file (Test Setup Photo).

4.2.6 EUT OPERATING CONDITIONS

Same as 4.1.6.



4.2.7 TEST RESULTS

CONDUCTED WORST-CASE DATA :

Phase	Line (L)	Detector Function	Quasi-Peak (QP) / Average (AV)
-------	----------	-------------------	--------------------------------

Frequency (MHz)	QuasiPeak (dB μ V)	CAverage (dB μ V)	Limit (dB μ V)	Margin (dB)	Line	Filter	Corr. (dB)
0.150000	---	20.86	56.00	35.14	L	ON	9.6
0.150000	35.82	---	66.00	30.18	L	ON	9.6
0.744000	---	25.90	46.00	20.10	L	ON	9.7
0.744000	35.02	---	56.00	20.98	L	ON	9.7
1.264000	---	29.33	46.00	16.67	L	ON	9.7
1.264000	38.73	---	56.00	17.27	L	ON	9.7
1.412000	---	29.36	46.00	16.64	L	ON	9.7
1.412000	39.10	---	56.00	16.90	L	ON	9.7
2.708000	---	26.42	46.00	19.58	L	ON	9.7
2.708000	34.74	---	56.00	21.26	L	ON	9.7
3.780000	---	25.11	46.00	20.89	L	ON	9.7
3.780000	33.09	---	56.00	22.91	L	ON	9.7

- REMARKS:**
1. Q.P. and AV. are abbreviations of quasi-peak and average individually.
 2. "-": The Quasi-peak reading value also meets average limit and measurement with the average detector is unnecessary.
 3. The emission levels of other frequencies were very low against the limit.
 4. Margin value = Emission level - Limit value
 5. Correction factor = Insertion loss + Cable loss
 6. Emission Level = Correction Factor + Reading Value.

Full Spectrum

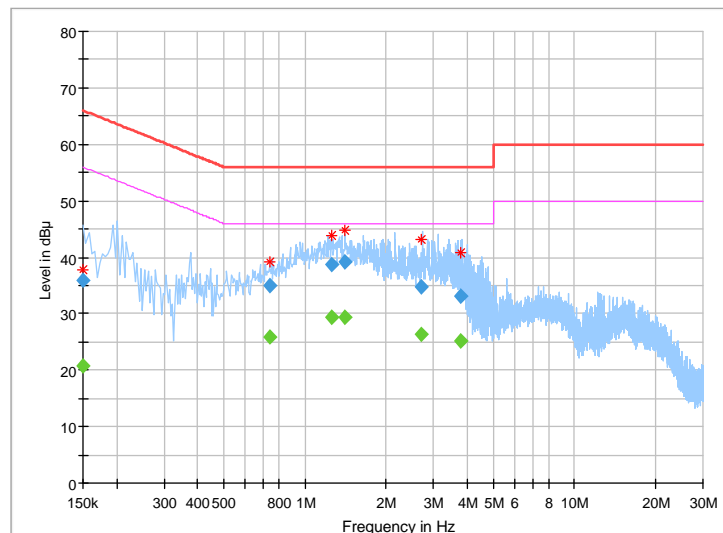

Phase	Neutral (N)	Detector Function	Quasi-Peak (QP) / Average (AV)
-------	-------------	-------------------	--------------------------------

Frequency (MHz)	QuasiPeak (dBuV)	CAverage (dBuV)	Limit (dBuV)	Margin (dB)	Line	Filter	Corr. (dB)
0.672000	---	27.58	46.00	18.42	N	ON	10.0
0.672000	38.05	---	56.00	17.95	N	ON	10.0
1.076000	---	32.24	46.00	13.76	N	ON	9.9
1.076000	42.42	---	56.00	13.58	N	ON	9.9
1.366000	---	32.64	46.00	13.36	N	ON	9.9
1.366000	43.67	---	56.00	12.33	N	ON	9.9
2.496000	---	29.81	46.00	16.19	N	ON	9.8
2.496000	41.26	---	56.00	14.74	N	ON	9.8
3.600000	---	31.08	46.00	14.92	N	ON	9.8
3.600000	40.38	---	56.00	15.62	N	ON	9.8
14.992000	---	25.12	50.00	24.88	N	ON	9.9
14.992000	34.65	---	60.00	25.35	N	ON	9.9

- REMARKS:**
1. Q.P. and AV. are abbreviations of quasi-peak and average individually.
 2. "-": The Quasi-peak reading value also meets average limit and measurement with the average detector is unnecessary.
 3. The emission levels of other frequencies were very low against the limit.
 4. Margin value = Emission level - Limit value
 5. Correction factor = Insertion loss + Cable loss
 6. Emission Level = Correction Factor + Reading Value.

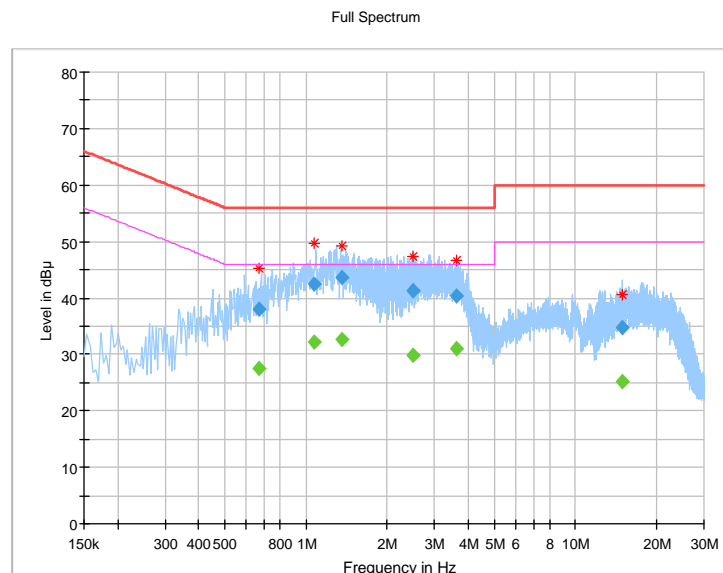



POWER LINE EMISSION DATA:

Phase	Line (L)	Detector Function	Quasi-Peak (QP) / Average (AV)
-------	----------	-------------------	--------------------------------

Frequency (MHz)	QuasiPeak (dBµV)	CAverage (dBµV)	Limit (dBµV)	Margin (dB)	Line	Filter	Corr. (dB)
0.468000	---	9.44	46.55	37.11	L1	ON	9.7
0.468000	17.89	---	56.55	38.66	L1	ON	9.7
1.820000	---	19.94	46.00	26.06	L1	ON	9.7
1.820000	24.10	---	56.00	31.90	L1	ON	9.7
3.088000	---	14.43	46.00	31.57	L1	ON	9.7
3.088000	17.66	---	56.00	38.34	L1	ON	9.7
5.540000	---	19.26	50.00	30.74	L1	ON	9.7
5.540000	26.23	---	60.00	33.77	L1	ON	9.7
6.224000	---	17.69	50.00	32.31	L1	ON	9.8
6.224000	22.48	---	60.00	37.52	L1	ON	9.8
12.068000	---	27.18	50.00	22.82	L1	ON	9.9
12.068000	32.40	---	60.00	27.60	L1	ON	9.9

- REMARKS:**
1. Q.P. and AV. are abbreviations of quasi-peak and average individually.
 2. "-": The Quasi-peak reading value also meets average limit and measurement with the average detector is unnecessary.
 3. The emission levels of other frequencies were very low against the limit.
 4. Margin value = Emission level - Limit value
 5. Correction factor = Insertion loss + Cable loss
 6. Emission Level = Correction Factor + Reading Value.

Full Spectrum

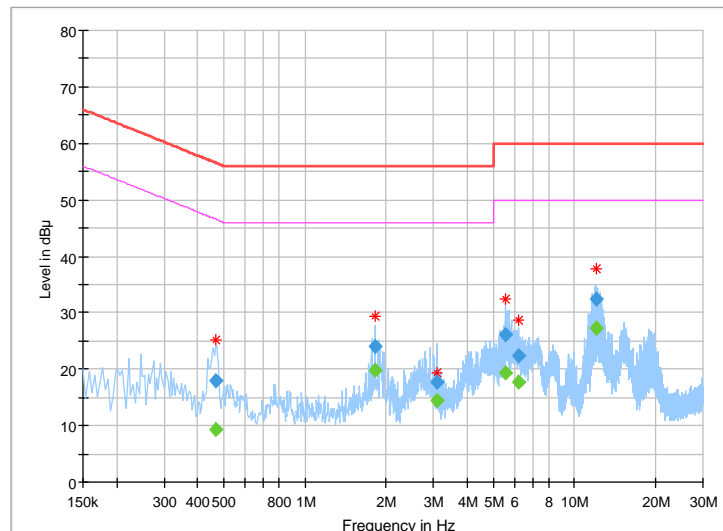

Phase	Neutral (N)	Detector Function	Quasi-Peak (QP) / Average (AV)
-------	-------------	-------------------	--------------------------------

Frequency (MHz)	QuasiPeak (dBuV)	CAverage (dBuV)	Limit (dBuV)	Margin (dB)	Line	Filter	Corr. (dB)
0.468000	---	12.84	46.55	33.71	N	ON	10.1
0.468000	22.91	---	56.55	33.64	N	ON	10.1
1.820000	---	25.04	46.00	20.96	N	ON	9.8
1.820000	28.95	---	56.00	27.05	N	ON	9.8
5.768000	---	24.54	50.00	25.46	N	ON	9.8
5.768000	29.00	---	60.00	31.00	N	ON	9.8
6.980000	---	14.17	50.00	35.83	N	ON	9.8
6.980000	23.35	---	60.00	36.65	N	ON	9.8
12.072000	---	28.77	50.00	21.23	N	ON	9.9
12.072000	35.90	---	60.00	24.10	N	ON	9.9
18.900000	---	22.49	50.00	27.51	N	ON	10.0
18.900000	28.95	---	60.00	31.05	N	ON	10.0

- REMARKS:**
1. Q.P. and AV. are abbreviations of quasi-peak and average individually.
 2. "-": The Quasi-peak reading value also meets average limit and measurement with the average detector is unnecessary.
 3. The emission levels of other frequencies were very low against the limit.
 4. Margin value = Emission level - Limit value
 5. Correction factor = Insertion loss + Cable loss
 6. Emission Level = Correction Factor + Reading Value.

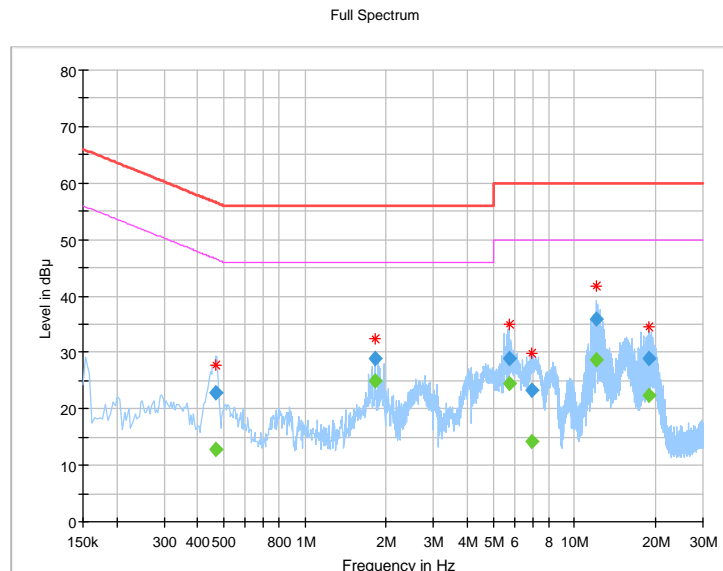



4.3 MAXIMUM CONDUCTED OUTPUT POWER MEASUREMENT

4.3.1 LIMITS OF MAXIMUM CONDUCTED OUTPUT POWER MEASUREMENT

Operation Band	EUT Category		LIMIT
U-NII-1		Outdoor Access Point	1 Watt (30 dBm) (Max. e.i.r.p \leq 125mW(21 dBm) at any elevation angle above 30 degrees as measured from the horizon)
		Fixed point-to-point Access Point	1 Watt (30 dBm)
		Indoor Access Point	1 Watt (30 dBm)
	√	Client devices	250mW (24 dBm)
U-NII-2A	√		250mW (24 dBm) or 11 dBm+10 log B*
U-NII-2C	√		250mW (24 dBm) or 11 dBm+10 log B*
U-NII-3	√		1 Watt (30 dBm)

NOTE: Where B is the 26dB emission bandwidth in MHz.

4.3.2 TEST SETUP

FOR POWER OUTPUT MEASUREMENT

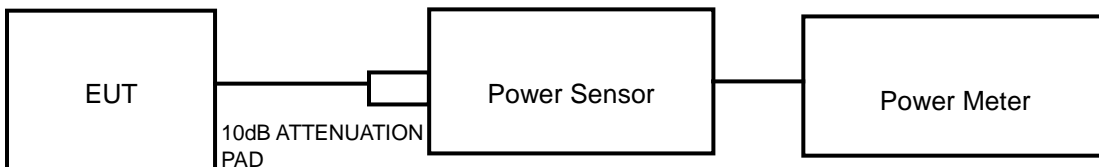

FOR 26dB BANDWIDTH

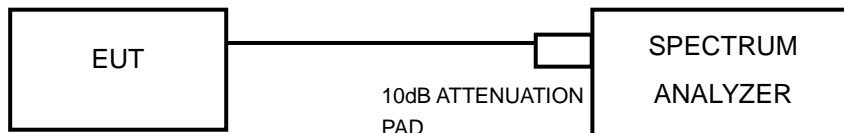

4.3.3 TEST INSTRUMENTS

Refer to section 4.1.3 to get information of above instrument.

4.3.4 TEST PROCEDURE

FOR POWER MEASUREMENT

Method PM is used to perform output power measurement, trigger and gating function of wide band power meter is enabled to measure max output power of TX on burst. Duty factor is not added to measured value.

FOR 99 PERCENT OCCUPIED BANDWIDTH

The following procedure shall be used for measuring (99 %) power bandwidth:

1. Set center frequency to the nominal EUT channel center frequency.
2. Set span = 1.5 times to 5.0 times the OBW.
3. Set RBW = 1 % to 5 % of the OBW
4. Set VBW $\geq 3 \cdot$ RBW
5. Video averaging is not permitted. Where practical, a sample detection and single sweep mode shall be used. Otherwise, peak detection and max hold mode (until the trace stabilizes) shall be used.
6. Use the 99 % power bandwidth function of the instrument (if available).
7. If the instrument does not have a 99 % power bandwidth function, the trace data points are recovered and directly summed in power units. The recovered amplitude data points, beginning at the lowest frequency, are placed in a running sum until 0.5 % of the total is reached; that frequency is recorded as the lower frequency. The process is repeated until 99.5 % of the total is reached; that frequency is recorded as the upper frequency. The 99% occupied bandwidth is the difference between these two frequencies.



FOR 26dB BANDWIDTH

- 1) Set RBW = approximately 1% of the emission bandwidth.
- 2) Set the VBW > RBW.
- 3) Detector = Peak.
- 4) Trace mode = max hold.
- 5) Measure the maximum width of the emission that is 26 dB down from the peak of the emission. Compare this with the RBW setting of the analyzer. Readjust RBW and repeat measurement as needed until the RBW/EBW ratio is approximately 1%.

FOR 6dB BANDWIDTH

1. Set RBW = 100 kHz.
2. Set the video bandwidth (VBW) ≥ 3 RBW.
3. Detector = Peak.
4. Trace mode = max hold.
5. Sweep = auto couple.
6. Allow the trace to stabilize.
7. Measure the maximum width of the emission that is constrained by the frequencies associated with the two outermost amplitude points (upper and lower frequencies) that are attenuated by 6 dB relative to the maximum level measured in the fundamental emission.

4.3.5 DEVIATION FROM TEST STANDARD

No deviation.

4.3.6 EUT OPERATING CONDITIONS

The software provided by client to enable the EUT under transmission condition continuously at specific channel frequencies individually.



4.3.7 TEST RESULTS

OUTPUT POWER:

802.11a

CHANNEL	CHANNEL FREQUENCY (MHz)	AVERAGE POWER (mW)	AVERAGE POWER (dBm)	POWER LIMIT (dBm)	PASS/FAIL
36	5180	12.589	11.00	24	PASS
40	5200	12.882	11.10	24	PASS
48	5240	12.706	11.04	24	PASS
52	5260	13.152	11.19	24	PASS
60	5300	12.359	10.92	24	PASS
64	5320	12.882	11.10	24	PASS
100	5500	12.106	10.83	24	PASS
116	5580	12.274	10.89	24	PASS
140	5700	12.303	10.90	24	PASS
149	5745	13.122	11.18	30	PASS
157	5785	12.794	11.07	30	PASS
161	5805	12.560	10.99	30	PASS



802.11n (20MHz)

CHANNEL	CHANNEL FREQUENCY (MHz)	AVERAGE POWER (mW)	AVERAGE POWER (dBm)	POWER LIMIT (dBm)	PASS/FAIL
36	5180	12.503	10.97	24	PASS
40	5200	12.647	11.02	24	PASS
48	5240	12.618	11.01	24	PASS
52	5260	11.995	10.79	24	PASS
60	5300	12.417	10.94	24	PASS
64	5320	12.303	10.90	24	PASS
100	5500	12.023	10.80	24	PASS
116	5580	12.106	10.83	24	PASS
140	5700	12.853	11.09	24	PASS
149	5745	12.589	11.00	30	PASS
157	5785	12.531	10.98	30	PASS
161	5805	12.445	10.95	30	PASS

802.11n (40MHz)

CHANNEL	CHANNEL FREQUENCY (MHz)	AVERAGE POWER (mW)	AVERAGE POWER (dBm)	POWER LIMIT (dBm)	PASS/FAIL
38	5190	12.246	10.88	24	PASS
46	5230	11.995	10.79	24	PASS
54	5270	12.853	11.09	24	PASS
62	5310	12.359	10.92	24	PASS
102	5510	12.531	10.98	24	PASS
110	5550	11.995	10.79	24	PASS
134	5670	11.776	10.71	24	PASS
151	5755	12.190	10.86	30	PASS
159	5795	12.331	10.91	30	PASS



99% OCCUPIED BANDWIDTH & 26dB BANDWIDTH/6dB BANDWIDTH:

802.11a

CHANNEL	CHANNEL FREQUENCY (MHz)	99% OCCUPIED BANDWIDTH	26dB BANDWIDTH (MHz)	PASS/FAIL
36	5180	16.56	22.50	PASS
40	5200	16.68	21.86	PASS
48	5240	16.68	22.16	PASS
52	5260	16.50	22.38	PASS
60	5300	16.74	22.20	PASS
64	5320	16.62	23.91	PASS
100	5500	16.62	22.41	PASS
116	5580	16.74	22.33	PASS
140	5700	16.68	22.79	PASS
CHANNEL	CHANNEL FREQUENCY (MHz)	99% OCCUPIED BANDWIDTH	6dB BANDWIDTH (MHz)	PASS/FAIL
149	5745	16.92	16.35	PASS
157	5785	16.92	16.37	PASS
161	5805	16.80	16.36	PASS



802.11n (20MHz)

CHANNEL	CHANNEL FREQUENCY (MHz)	99% OCCUPIED BANDWIDTH	26dB BANDWIDTH (MHz)	PASS/FAIL
36	5180	17.76	22.25	PASS
40	5200	17.88	22.24	PASS
48	5240	17.76	22.47	PASS
52	5260	17.88	22.72	PASS
60	5300	17.88	22.59	PASS
64	5320	17.82	23.12	PASS
100	5500	17.70	22.42	PASS
116	5580	17.70	22.59	PASS
140	5700	17.70	23.80	PASS
CHANNEL	CHANNEL FREQUENCY (MHz)	99% OCCUPIED BANDWIDTH	6dB BANDWIDTH (MHz)	PASS/FAIL
149	5745	17.88	17.57	PASS
157	5785	18.00	17.57	PASS
161	5805	17.88	17.57	PASS



802.11n (40MHz)

CHANNEL	CHANNEL FREQUENCY (MHz)	99% OCCUPIED BANDWIDTH	26dB BANDWIDTH (MHz)	PASS/FAIL
38	5190	36.30	46.01	PASS
46	5230	36.30	46.76	PASS
54	5270	36.36	45.88	PASS
62	5310	36.36	46.13	PASS
102	5510	36.42	45.11	PASS
110	5550	36.36	45.34	PASS
134	5670	36.36	46.16	PASS
CHANNEL	CHANNEL FREQUENCY (MHz)	99% OCCUPIED BANDWIDTH	6dB BANDWIDTH (MHz)	PASS/FAIL
151	5755	36.30	35.14	PASS
159	5795	36.18	35.28	PASS



**BUREAU
VERITAS**

Test Report No.: RF160524W004-6

For U-NII-1:

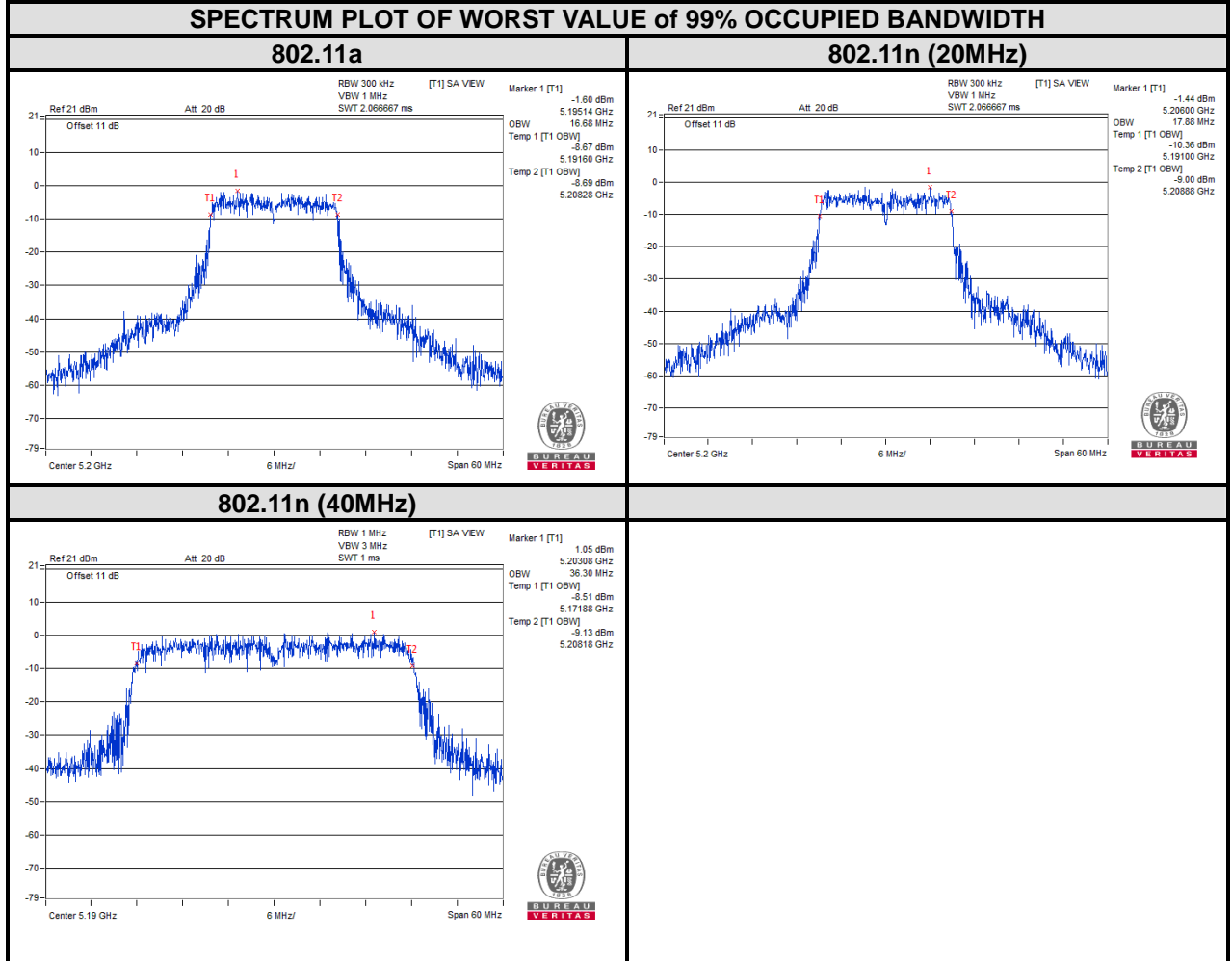



BUREAU VERITAS

Test Report No.: RF160524W004-6

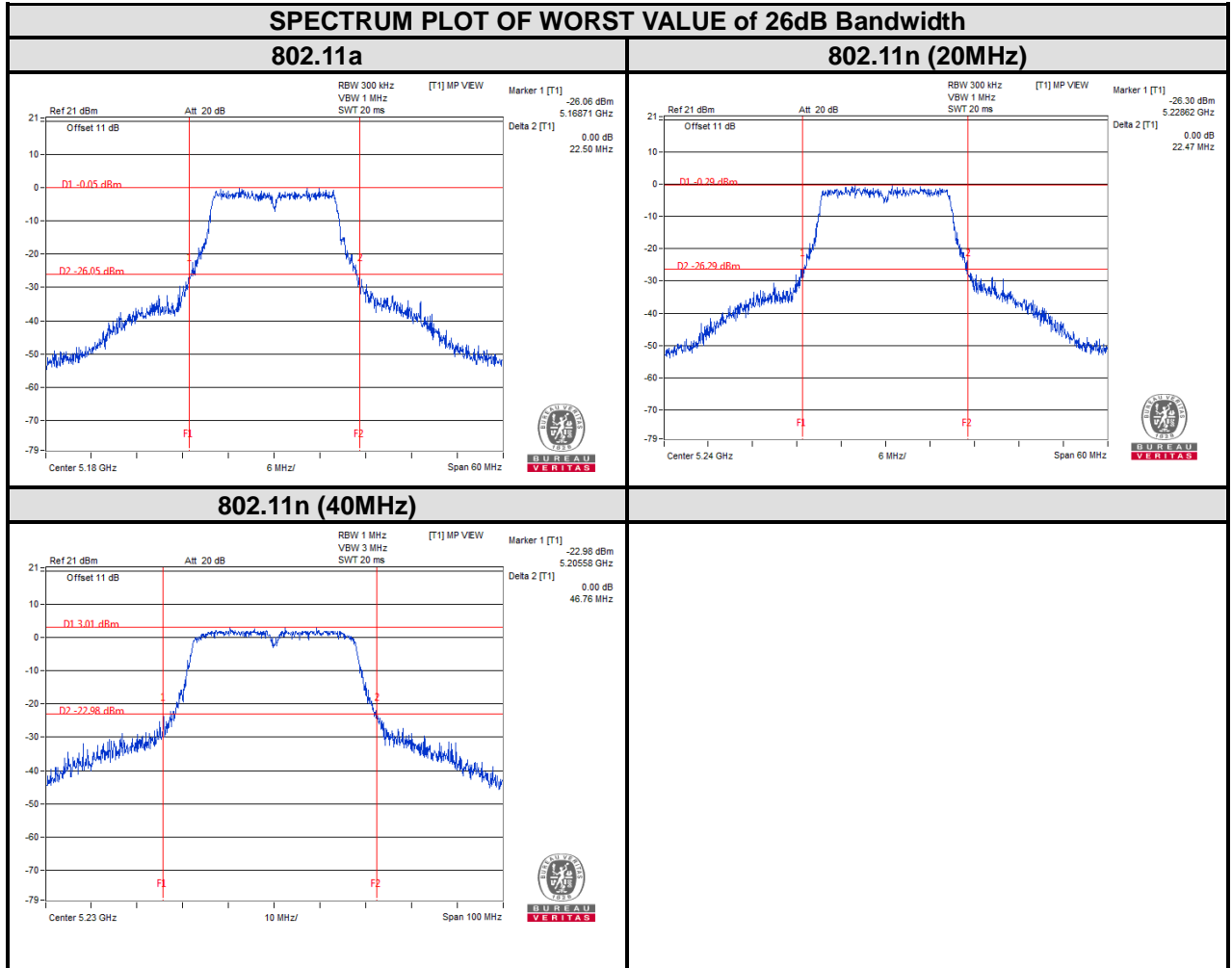



BUREAU VERITAS

Test Report No.: RF160524W004-6

For U-NII-2A:

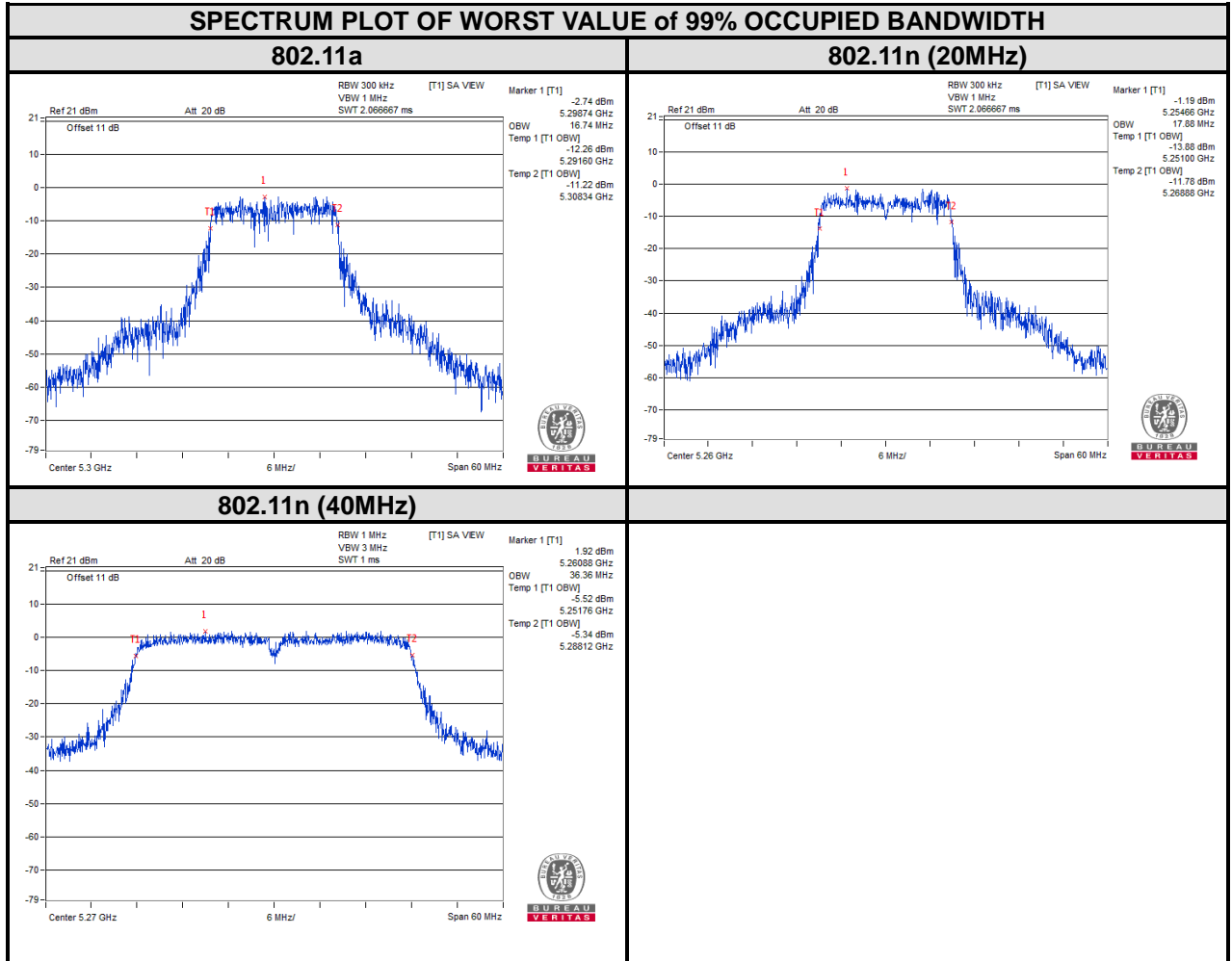



BUREAU VERITAS

Test Report No.: RF160524W004-6

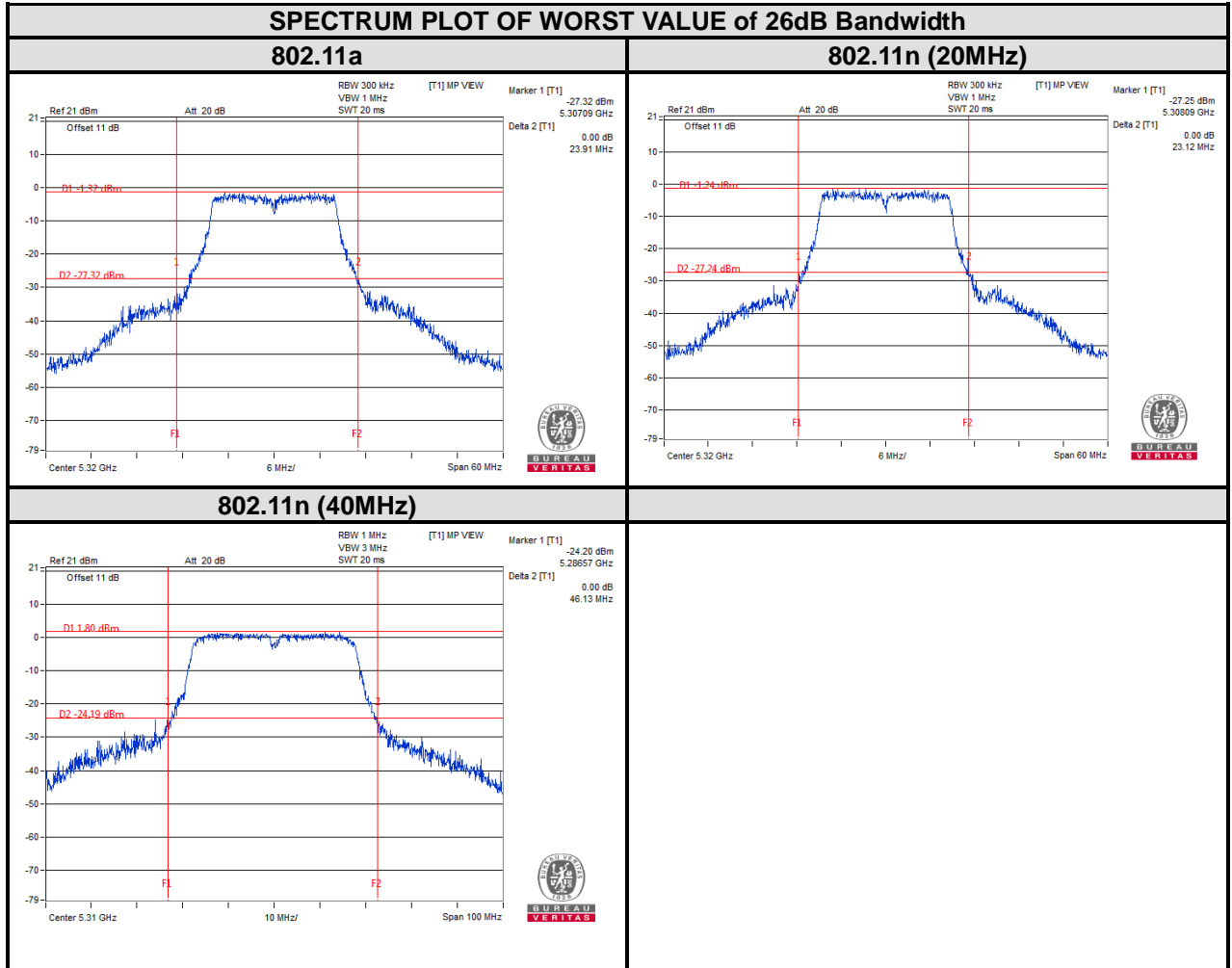



BUREAU VERITAS

Test Report No.: RF160524W004-6

For U-NII-2C:

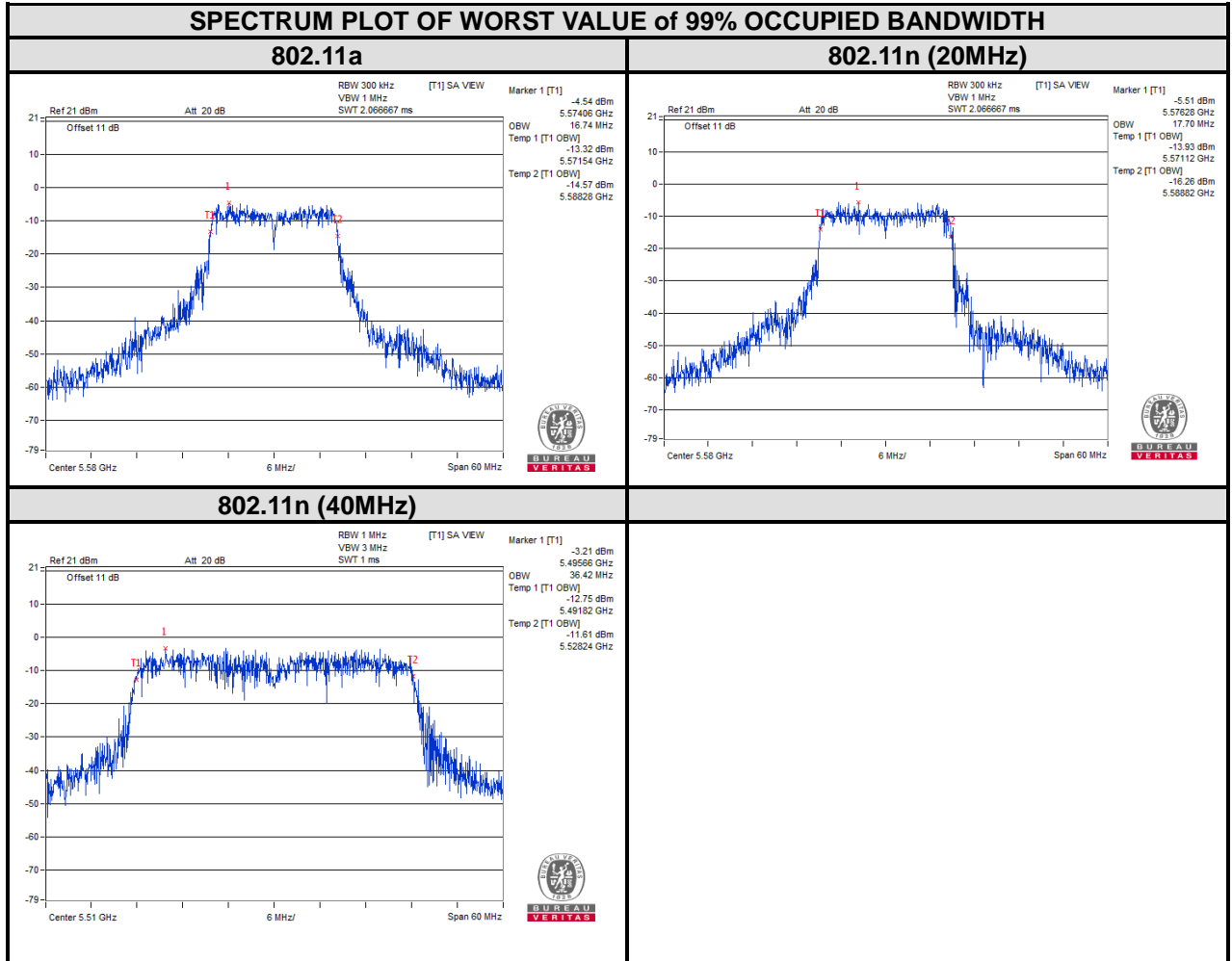



BUREAU VERITAS

Test Report No.: RF160524W004-6

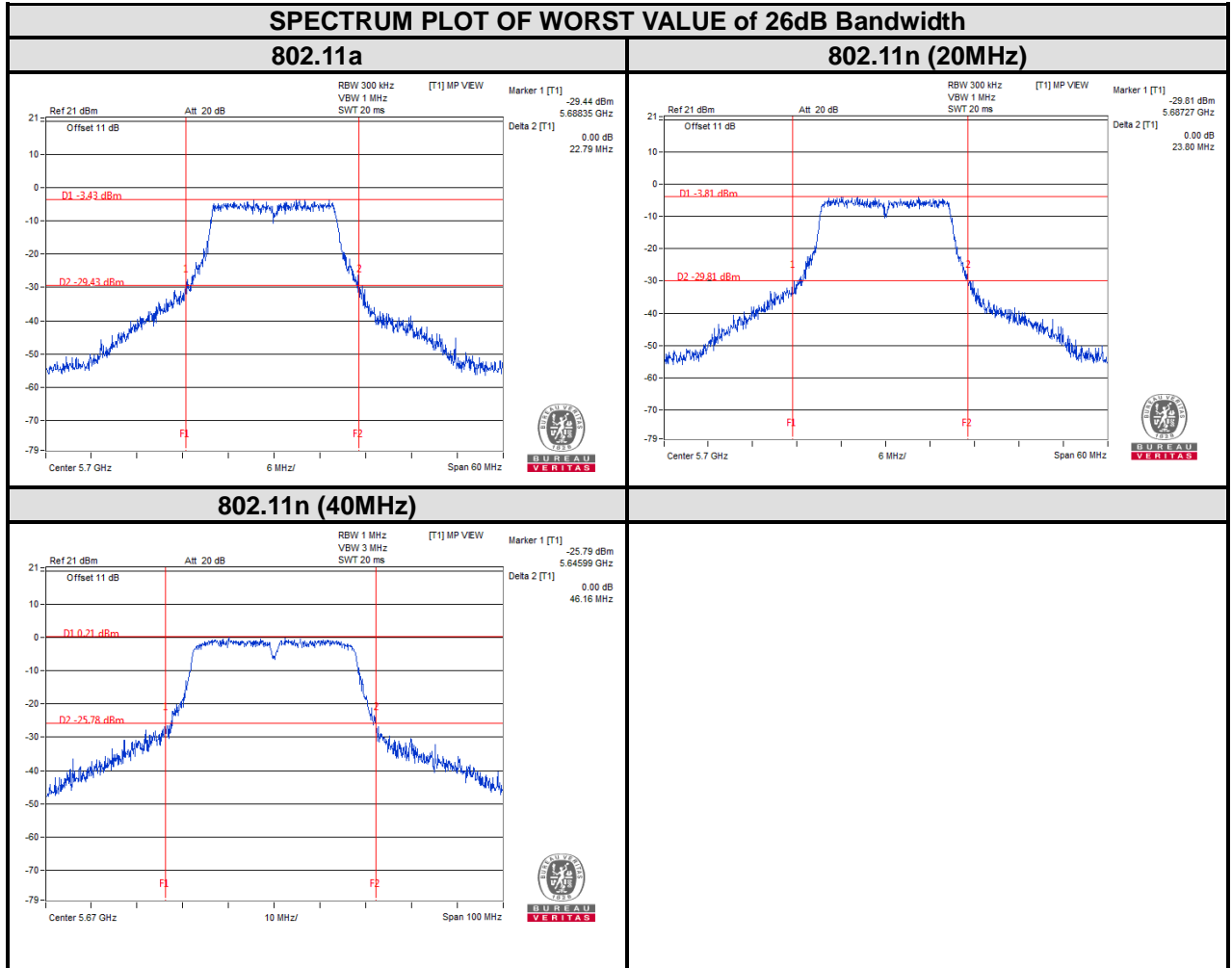



**BUREAU
VERITAS**

Test Report No.: RF160524W004-6

For U-NII-3:

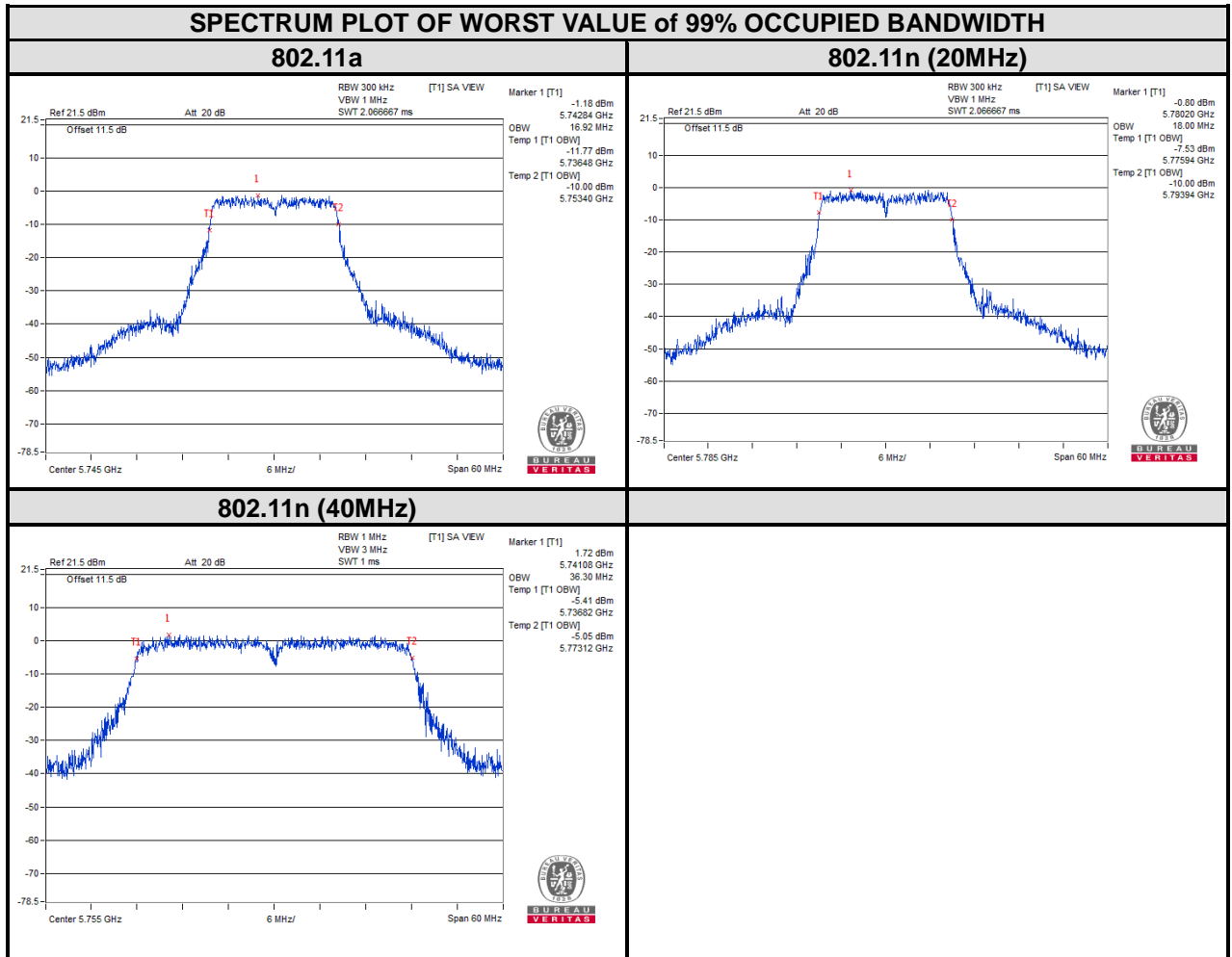



BUREAU VERITAS

Test Report No.: RF160524W004-6

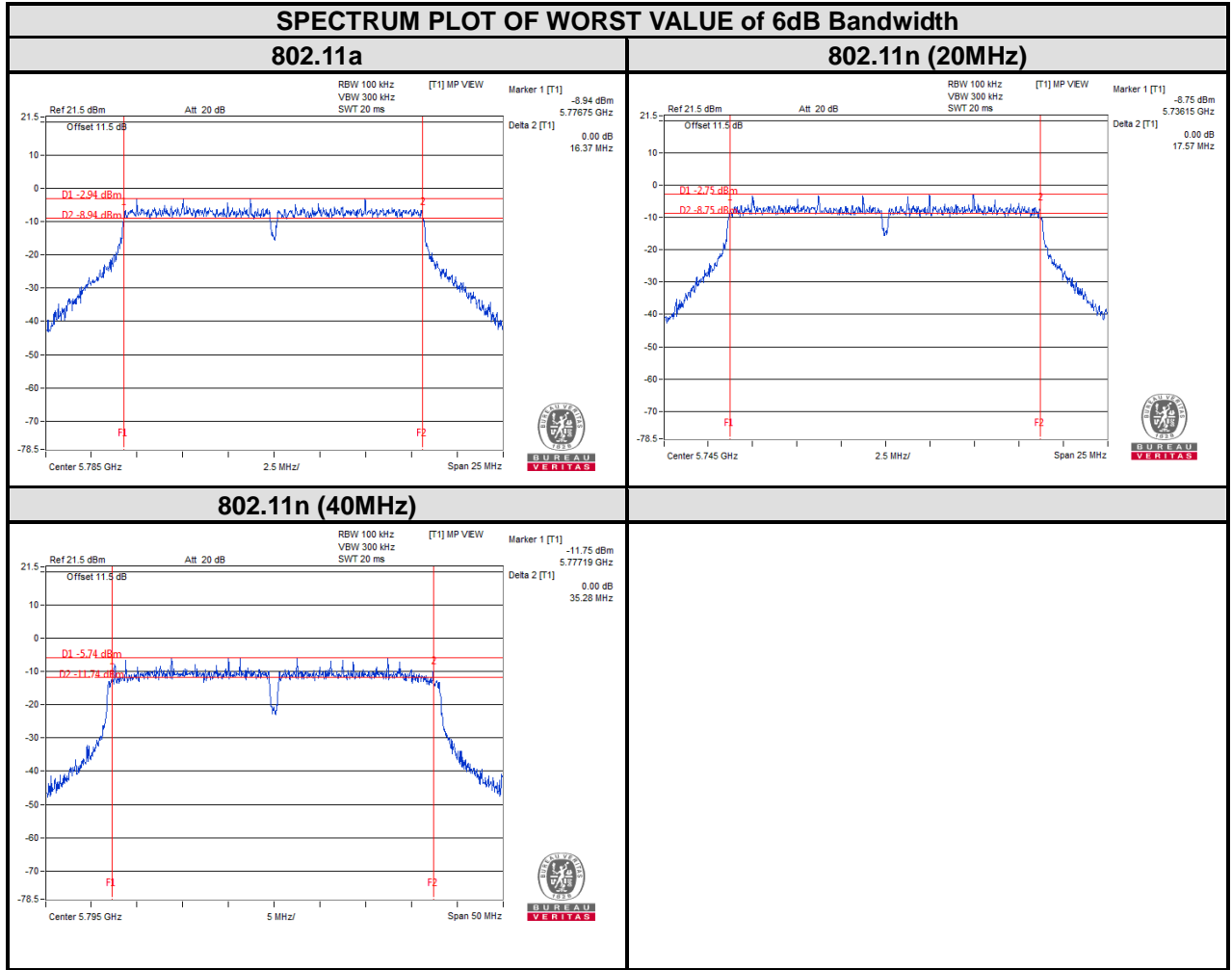



4.4 PEAK POWER SPECTRAL DENSITY MEASUREMENT

4.4.1 LIMITS OF PEAK POWER SPECTRAL DENSITY MEASUREMENT

Operation Band	EUT Category		LIMIT
U-NII-1		Outdoor Access Point	17dBm/ MHz
		Fixed point-to-point Access Point	
		Indoor Access Point	
	√	Client devices	11dBm/ MHz
U-NII-2A	√		11dBm/ MHz
U-NII-2C	√		11dBm/ MHz
U-NII-3	√		30dBm/ 500kHz

4.4.2 TEST SETUP

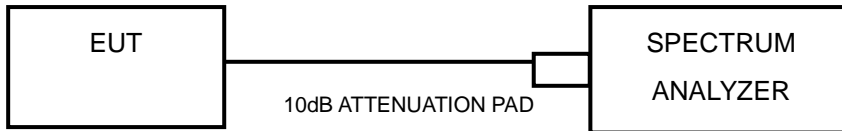

4.4.3 TEST INSTRUMENTS

Refer to section 4.1.3 to get information of above instrument.

4.4.4 TEST PROCEDURES

Using method SA-1

- 1) Set span to encompass the entire emission bandwidth (EBW) of the signal.
- 2) Set RBW = 30 KHz, Set VBW ≥ 1 MHz, Detector = RMS
- 3) Set Channel power measure = 1MHz
- 4) Sweep time = auto, trigger set to “free run”.
- 5) Trace average at least 100 traces in power averaging mode.
- 6) Record the max value



4.4.5 DEVIATION FROM TEST STANDARD

No deviation.

4.4.6 EUT OPERATING CONDITIONS

Same as 4.1.6.

4.4.7 TEST RESULTS

For U-NII-1, U-NII-2A & U-NII-2C:

802.11a

CHANNEL	FREQUENCY (MHz)	PSD w/o Duty Factor (dBm/MHz)	Duty Factor	PSD with Duty Factor (dBm/MHz)	MAXIMUM LIMIT (dBm/MHz)	PASS/FAIL
36	5180	1.63	0.60	2.23	11	PASS
40	5200	2.90	0.60	3.5	11	PASS
48	5240	2.37	0.60	2.97	11	PASS
52	5260	1.46	0.60	2.06	11	PASS
60	5300	1.36	0.60	1.96	11	PASS
64	5320	1.21	0.60	1.81	11	PASS
100	5500	-1.62	0.60	-1.02	11	PASS
116	5580	-0.13	0.60	0.47	11	PASS
140	5700	-0.81	0.60	-0.21	11	PASS



802.11n (20MHz)

CHANNEL	FREQUENCY (MHz)	PSD w/o Duty Factor (dBm/MHz)	Duty Factor	PSD with Duty Factor (dBm/MHz)	MAXIMUM LIMIT (dBm/MHz)	PASS/FAIL
36	5180	2.14	0.70	2.84	11	PASS
40	5200	1.20	0.70	1.9	11	PASS
48	5240	1.91	0.70	2.61	11	PASS
52	5260	1.09	0.70	1.79	11	PASS
60	5300	1.43	0.70	2.13	11	PASS
64	5320	0.51	0.70	1.21	11	PASS
100	5500	-2.75	0.70	-2.05	11	PASS
116	5580	-1.65	0.70	-0.95	11	PASS
140	5700	-1.79	0.70	-1.09	11	PASS

802.11n (40MHz)

CHANNEL	FREQUENCY (MHz)	PSD w/o Duty Factor (dBm/MHz)	Duty Factor	PSD with Duty Factor (dBm/MHz)	MAXIMUM LIMIT (dBm/MHz)	PASS/FAIL
38	5190	-2.20	1.26	-0.94	11	PASS
46	5230	-1.90	1.26	-0.64	11	PASS
54	5270	-1.47	1.26	-0.21	11	PASS
62	5310	-2.21	1.26	-0.95	11	PASS
102	5510	-4.89	1.26	-3.63	11	PASS
110	5550	-3.84	1.26	-2.58	11	PASS
134	5670	-4.67	1.26	-3.41	11	PASS



For U-NII-3:

802.11a

CHANNEL	FREQUENCY (MHz)	PSD w/o Duty Factor (dBm/500kHz)	Duty Factor	PSD with Duty Factor (dBm/500kHz)	LIMIT (dBm/500kHz)	PASS /FAIL
149	5745	3.40	0.60	4.00	30	PASS
157	5785	3.47	0.60	4.07	30	PASS
161	5805	3.04	0.60	3.64	30	PASS

802.11n (20MHz)

CHANNEL	FREQUENCY (MHz)	PSD w/o Duty Factor (dBm/500kHz)	Duty Factor	PSD with Duty Factor (dBm/500kHz)	LIMIT (dBm/500kHz)	PASS /FAIL
149	5745	3.09	0.70	3.79	30	PASS
157	5785	3.77	0.70	4.47	30	PASS
161	5805	2.48	0.70	3.18	30	PASS

802.11n (40MHz)

CHANNEL	FREQUENCY (MHz)	PSD w/o Duty Factor (dBm/500kHz)	Duty Factor	PSD with Duty Factor (dBm/500kHz)	LIMIT (dBm/500kHz)	PASS /FAIL
151	5755	0.35	1.26	1.61	30	PASS
159	5795	0.06	1.26	1.32	30	PASS



**BUREAU
VERITAS**

Test Report No.: RF160524W004-6

For 5180~5240MHz

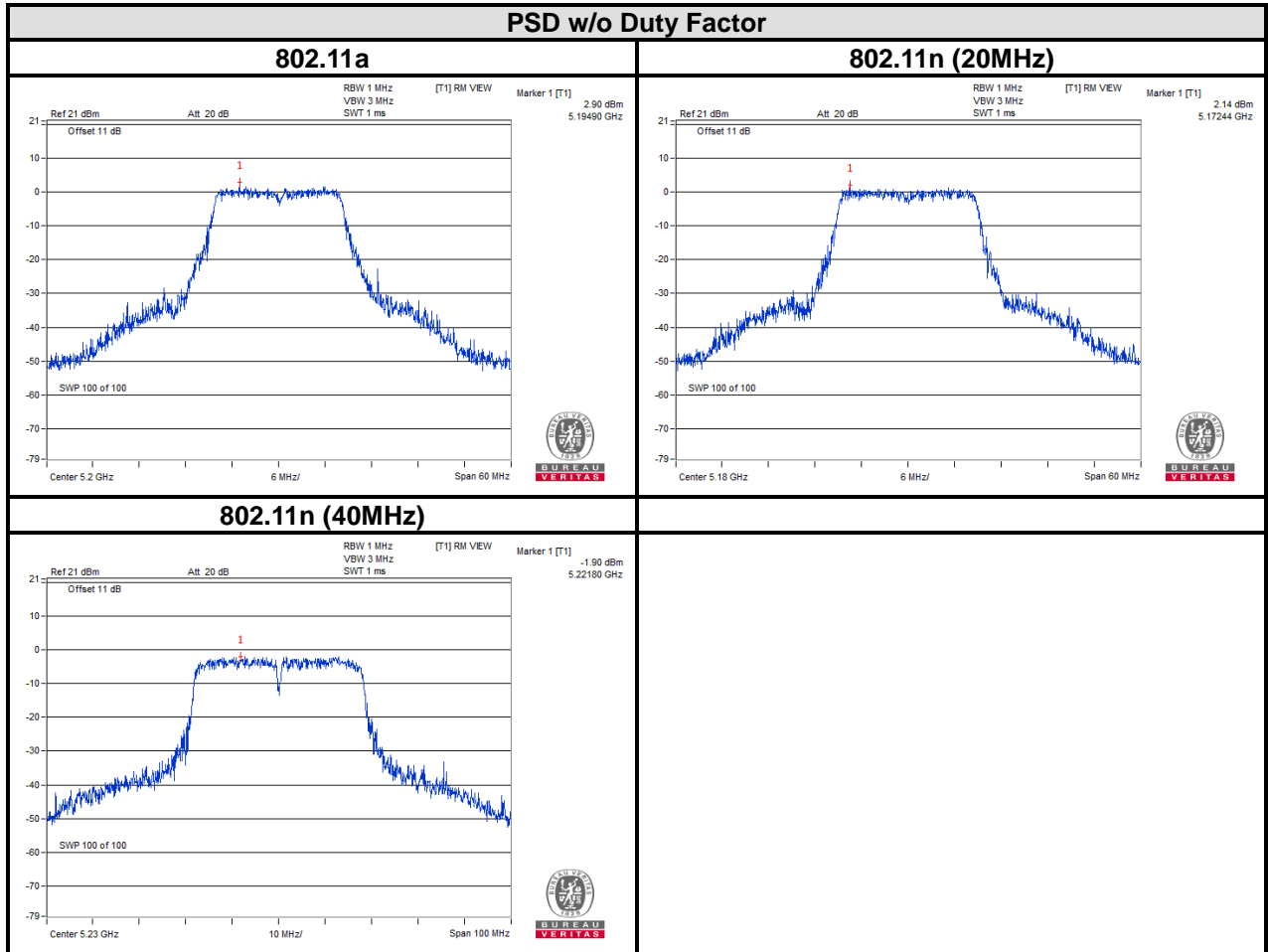



**BUREAU
VERITAS**

Test Report No.: RF160524W004-6

For 5260~5320MHz

PSD w/o Duty Factor

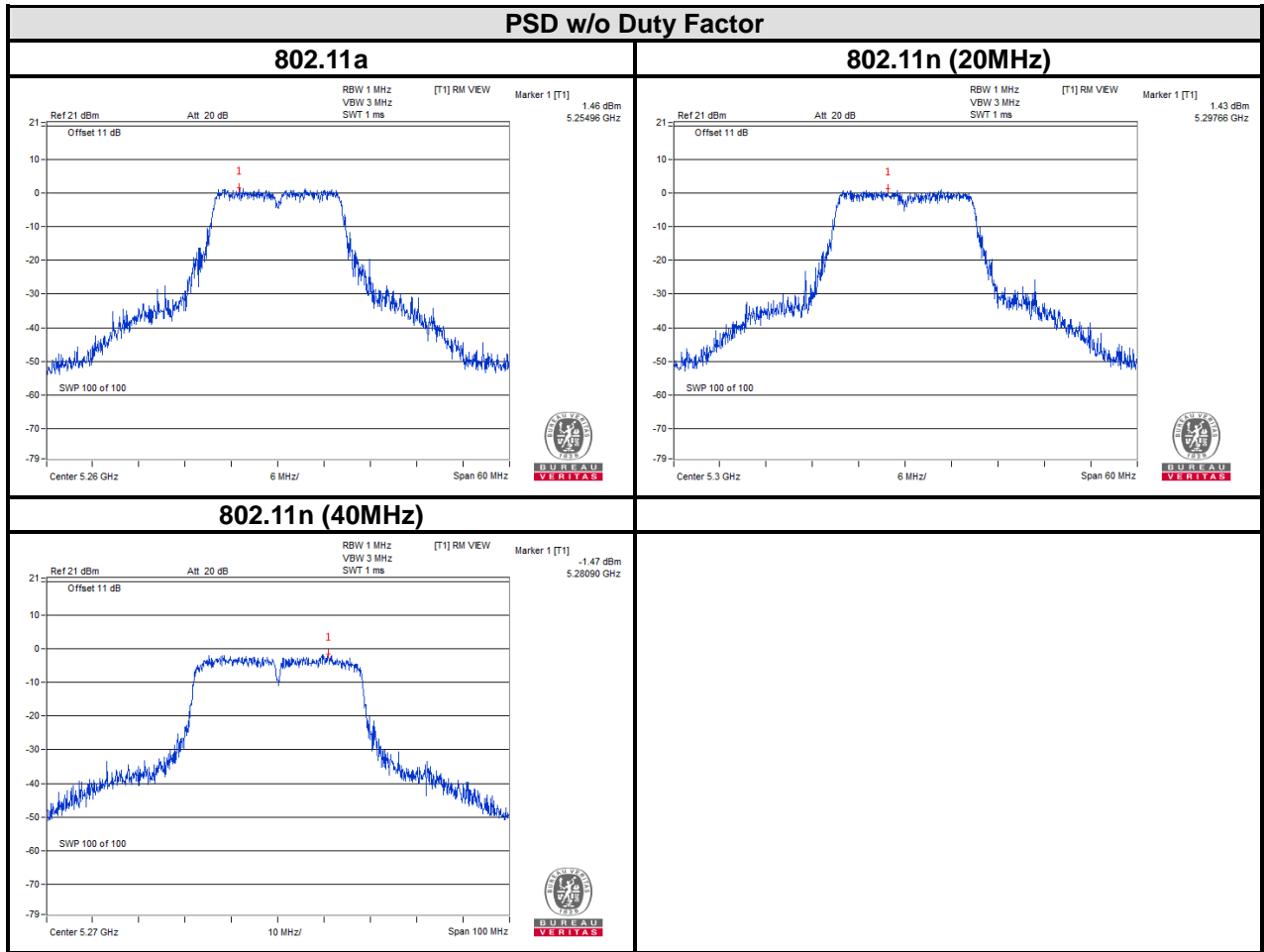



BUREAU VERITAS

Test Report No.: RF160524W004-6

For 5500~5700MHz

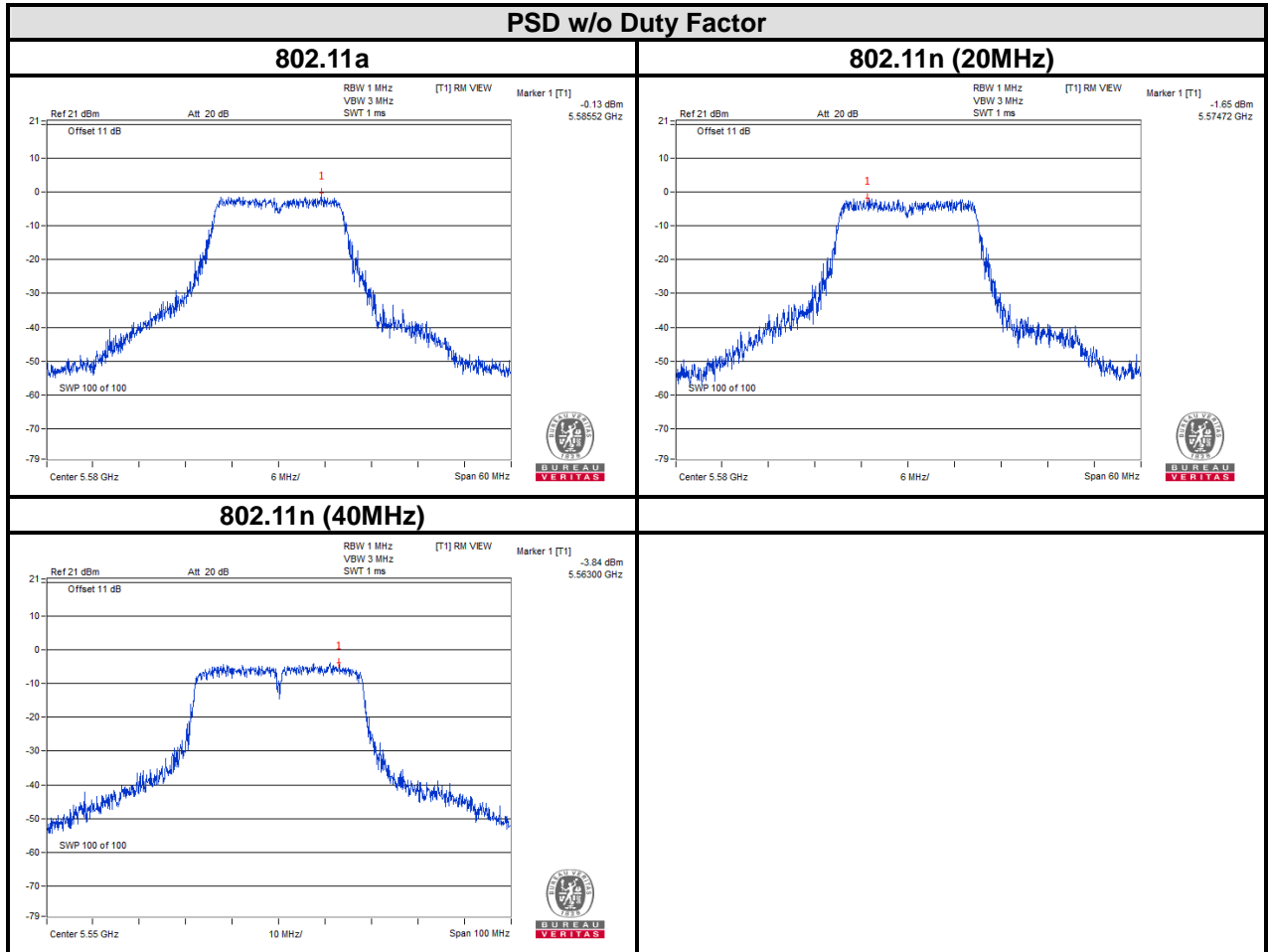



BUREAU VERITAS

Test Report No.: RF160524W004-6

For 5745~5805MHz

PSD w/o Duty Factor	
<p>802.11a</p> <p>Ref 21.5 dBm Alt 20 dB RBW 1 MHz VBW 3 MHz SWT 50 ms [T1] MP VIEW Marker 1 [T1] 6.48 dBm 5.78202 GHz</p> <p>Offset 11.5 dB</p> <p>Center 5.785 GHz 2.45 MHz/ Span 24.56 MHz</p>	<p>802.11n (20MHz)</p> <p>Ref 21.5 dBm Alt 20 dB RBW 1 MHz VBW 3 MHz SWT 50 ms [T1] MP VIEW Marker 1 [T1] 6.78 dBm 5.78536 GHz</p> <p>Offset 11.5 dB</p> <p>Center 5.785 GHz 2.63 MHz/ Span 26.36 MHz</p>
<p>Note: The peak power spectral density is a “calculated” value derived from the conducted value: 6.48dBm/MHz=3.47dBm/500kHz</p>	<p>Note: The peak power spectral density is a “calculated” value derived from the conducted value: 6.78dBm/MHz=3.77dBm/500kHz</p>
<p>802.11n (40MHz)</p> <p>Ref 21.5 dBm Alt 20 dB RBW 1 MHz VBW 3 MHz SWT 50 ms [T1] MP VIEW Marker 1 [T1] 3.36 dBm 5.76443 GHz</p> <p>Offset 11.5 dB</p> <p>Center 5.755 GHz 5.27 MHz/ Span 52.71 MHz</p>	
<p>Note: The peak power spectral density is a “calculated” value derived from the conducted value: 3.36dBm/MHz=0.35dBm/500kHz</p>	



4.5 FREQUENCY STABILITY

4.5.1 LIMITS OF FREQUENCY STABILITY MEASUREMENT

The frequency of the carrier signal shall be maintained within band of operation

4.5.2 TEST SETUP

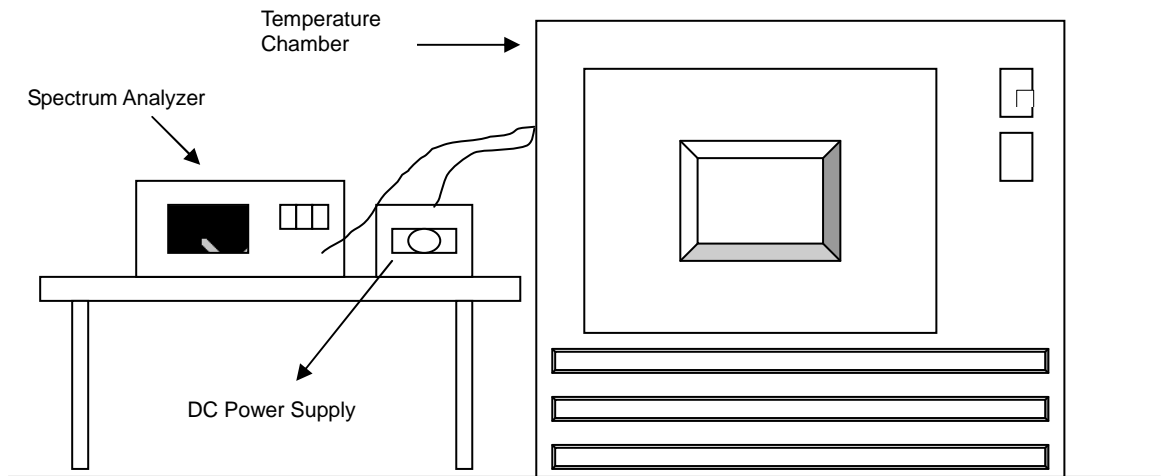

4.5.3 TEST INSTRUMENTS

Refer to section 4.1.3 to get information of above instrument.



4.5.4 TEST PROCEDURE

- a. The EUT was placed inside the environmental test chamber and powered by nominal DC voltage.
- b. Turn the EUT on and couple its output to a spectrum analyzer.
- c. Turn the EUT off and set the chamber to the highest temperature specified.
- d. Allow sufficient time (approximately 30 min) for the temperature of the chamber to stabilize, turn the EUT on and measure the operating frequency after 2, 5, and 10 minutes.
- e. Repeat step 2 and 3 with the temperature chamber set to the lowest temperature.
- f. The test chamber was allowed to stabilize at +20 degree C for a minimum of 30 minutes. The supply voltage was then adjusted on the EUT from 85% to 115% and the frequency record.

4.5.5 DEVIATION FROM TEST STANDARD

No deviation.

4.5.6 EUT OPERATING CONDITION

Set the EUT transmit at un-modulation mode to test frequency stability.



4.5.7 TEST RESULTS

FREQUENCY STABILITY VERSUS TEMP.									
OPERATING FREQUENCY: 5180MHz									
TEMP. (°C)	POWER SUPPLY (Vdc)	0 MINUTE		2 MINUTES		5 MINUTES		10 MINUTE	
		Measured Frequency (MHz)	Frequency Drift (ppm)	Measured Frequency (MHz)	Frequency Drift (ppm)	Measured Frequency (MHz)	Frequency Drift (ppm)	Measured Frequency (MHz)	Frequency Drift (ppm)
50	3.8	5179.9933	-1.293	5179.9927	-1.409	5180.002	0.386	5180.0006	0.116
40	3.8	5179.9788	-4.093	5179.9816	-3.552	5179.9768	-4.479	5179.9733	-5.154
30	3.8	5179.9768	-4.479	5179.9765	-4.537	5179.9779	-4.266	5179.974	-5.019
20	3.8	5179.9971	-0.560	5180.0002	0.039	5179.999	-0.193	5180.0036	0.695
10	3.8	5179.9718	-5.444	5179.9739	-5.039	5179.9748	-4.865	5179.9778	-4.286
0	3.8	5179.9854	-2.819	5179.9852	-2.857	5179.9824	-3.398	5179.9814	-3.591
-10	3.8	5179.9892	-2.085	5179.9918	-1.583	5179.988	-2.317	5179.9877	-2.375
-20	3.8	5179.9754	-4.749	5179.9719	-5.425	5179.9706	-5.676	5179.9765	-4.537
-30	3.8	5180.0225	4.344	5180.0136	2.625	5180.0138	2.664	5180.0233	4.498

FREQUENCY STABILITY VERSUS VOLTAGE									
OPERATING FREQUENCY: 5180MHz									
TEMP. (°C)	POWER SUPPLY (Vdc)	0 MINUTE		2 MINUTE		5 MINUTE		10 MINUTE	
		Measured Frequency (MHz)	Frequency Drift (ppm)	Measured Frequency (MHz)	Frequency Drift (ppm)	Measured Frequency (MHz)	Frequency Drift (ppm)	Measured Frequency (MHz)	Frequency Drift (ppm)
20	4.2	5179.9959	-0.792	5179.9991	-0.174	5179.9971	-0.560	5180.0035	0.676
	3.7	5179.9971	-0.560	5180.0002	0.039	5179.999	-0.193	5180.0036	0.695
	3.5	5179.9962	-0.734	5179.9994	-0.116	5179.998	-0.386	5180.0037	0.714



FREQUENCY STABILITY VERSUS TEMP.									
OPERATING FREQUENCY: 5805MHz									
TEMP. (°C)	POWER SUPPLY (Vdc)	0 MINUTE		2 MINUTES		5 MINUTES		10 MINUTE	
		Measured Frequency (MHz)	Frequency Drift (ppm)	Measured Frequency (MHz)	Frequency Drift (ppm)	Measured Frequency (MHz)	Frequency Drift (ppm)	Measured Frequency (MHz)	Frequency Drift (ppm)
50	3.8	5805.0244	4.203	5805.0234	4.031	5805.0164	2.825	5805.0203	3.497
40	3.8	5805.0115	1.981	5805.0107	1.843	5805.0109	1.878	5805.0062	1.068
30	3.8	5805.0103	1.774	5805.016	2.756	5805.0069	1.189	5805.0149	2.567
20	3.8	5805.003	0.517	5805.0006	0.103	5805.002	0.345	5805.0072	1.240
10	3.8	5805.0149	2.567	5805.0213	3.669	5805.0167	2.877	5805.0149	2.567
0	3.8	5804.989	-1.895	5804.9855	-2.498	5804.9869	-2.257	5804.9964	-0.620
-10	3.8	5804.9904	-1.654	5804.9786	-3.686	5804.9874	-2.171	5804.9869	-2.257
-20	3.8	5805.0106	1.826	5805.0146	2.515	5805.007	1.206	5805.0126	2.171
-30	3.8	5804.9896	-1.792	5804.9817	-3.152	5804.9866	-2.308	5804.9795	-3.531

FREQUENCY STABILITY VERSUS VOLTAGE									
OPERATING FREQUENCY: 5805MHz									
TEMP. (°C)	POWER SUPPLY (Vdc)	0 MINUTE		2 MINUTE		5 MINUTE		10 MINUTE	
		Measured Frequency (MHz)	Frequency Drift (ppm)	Measured Frequency (MHz)	Frequency Drift (ppm)	Measured Frequency (MHz)	Frequency Drift (ppm)	Measured Frequency (MHz)	Frequency Drift (ppm)
20	4.2	5805.0023	0.396	5804.9999	-0.017	5805.0002	0.034	5805.0062	1.068
	3.7	5805.003	0.517	5805.0006	0.103	5805.002	0.345	5805.0072	1.240
	3.5	5805.0018	0.310	5804.9994	-0.103	5805.0001	0.017	5805.0072	1.240



Test Report No.: RF160524W004-6

5 PHOTOGRAPHS OF THE TEST CONFIGURATION

Please refer to the attached file (Test Setup Photo).



6 APPENDIX A – MODIFICATIONS RECORDERS FOR ENGINEERING CHANGES TO THE EUT BY THE LAB

No modifications were made to the EUT by the lab during the test.

---END---