



HAC T-coil signal Test Report

Report No.: SRTC2011-HAC004-E0004

Product Name: CDMA 1X-EVDO Digital Mobile Phone
with Bluetooth

Model Name: Sonim XP3400-A-R1

Type Number: C21F007AA

Applicant: Sonim Technologies Inc.

Manufacturer: BYD COMPANY LIMITED

Specification: ANSI C63.19-2007

FCC ID: WYPC21F007AA

The State Radio_monitoring_center Testing Center (SRTC)

No.80 Beilishi Road Xicheng District Beijing, China

Tel: 86-10-68009202 Fax: 86-10-68009205

Executive summary

Test report no.:	SRTC2011-HAC004-E0004
Model Name:	Sonim XP3400-A-R1
Type Number:	C21F007AA
Date of test:	2011.7.2 to 2011.7.4
Date of report:	2011.7.12
Laboratory:	The State Radio_monitoring_center Testing Center (SRTC)
Test has been Carried out in accordance with:	ANSI C63.19-2007 American National standard Methods of Measurement of Compatibility between Wireless Communications Devices and Hearing Aids
Documentation:	The documentation of the testing performed on the tested devices is archived for 5 years at SRTC

Result summary:

Band & Mode	Category assessment T-coil signal quality	Pass/Fail
CDMA800	T3	PASS
CDMA1900	T3	PASS
Final M Category	T3	PASS

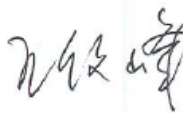
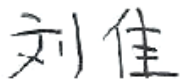
This Test Report Is Issued by: Mr. Song Qizhu Director of the test lab 	Checked by: Mr. Wang Junfeng Deputy director of the test lab 
Tested by: Ms. Liu Jia Test engineer 	Issued date: 2011.07.12

Tables of contents

1. General information	3
1.1 Notes of the test report.....	3
1.2 Information about the testing laboratory.....	3
1.3 Applicant’s details.....	3
1.4 Manufacturer’s details.....	3
1.5 Test Details.....	4
1.6 summary of T-coil results.....	4
1.6.1 T-coil coupling field intensity	4
1.6.1.1 Axial Field Intensity.....	4
1.6.1.2 Radial Field Intensity.....	4
1.6.2 Frequency Response at Axial Measurement Point.....	4
1.6.3 Signal Quality	5
2. EUT Description	5
2.1 picture of Device.....	5
3. Test conditions	5
3.1 Temperature and Humidity	5
3.2 Test Signal, Frequencies, and Output Power.....	5
3.3 WD Parameters	5
4. Description of the test equipment	6
4.1 Measurement system and components.....	6
4.1.1 Audio Magnetic Probe AM1DV2	6
4.1.2 Audio Magnetic Measurement Instrument AMMI.....	7
4.1.3 Audio Magnetic calibration Coil AMCC	7
4.1.4 Device Holder	7
4.2 Verification of the System	7
5. Description of the test procedure	7
5.1 Test Arch and Device Holder	7
5.2 Test positions.....	8
5.2.1 Scan area centered at the acoustic output.....	8
5.3 T-coil Scan Procedures	8
5.4 Measurement procedure and used test signals.....	9
5.5 T-coil Requirements and Category Limits	9
6. Measurement uncertainty	11
7. Results	12
APPENDIX A: MEASUREMENT SCAN	13
APPENDIX B: AUDIO MAGNETIC AM1DV3 S/N 1050	38

1. General information

1.1 Notes of the test report

The test report may only be reproduced or published in full. Reproduction or publication of extracts from the report requires the prior written permission of The State Radio_monitoring_center Testing Center (SRTC).

The test results relate only to individual items of the samples which have been tested.

1.2 Information about the testing laboratory

Company: The State Radio_monitoring_center Testing Center (SRTC)
Address: No.80 Beilishi Road, Xicheng District, Beijing China
City: Beijing
Country or Region: China
Contacted person: Wang Junfeng
Tel: +86 10 68009181 +86 10 68009202
Fax: +86 10 68009195 +86 10 68009205
Email: wangjf@srrc.org.cn / wangjunfeng@srtc.org.cn

1.3 Applicant's details

Company: Sonim Technologies Inc.
Address: 1875 S. Grant Street, Suite 620, San Mateo, CA 94402, USA
City: San Mateo
Country or Region: USA
Grantee Code: WYP
Contacted Person: Jasen Kolev
Tel: +1 650 504 4411
Fax: -----
Email: jasen@sonimtech.com

1.4 Manufacturer's details

Company: BYD COMPANY LIMITED
Address: Floor7, Building 5, No.3000 LongDong Avenue, Pudong District
City: Shanghai
Country or Region: P.R.China
Contacted Person: Wang Luhong
Tel: +86-021-61009669-72101
Fax: +86-021-61009668
Email: wang.luhong@byd.com

1.5 Test Details

FCC ID	WYPC21F007AA
Tx frequency	CDMA800:824MHz~849MHz CDMA1900:1850MHz~1910MHz
Rx frequency	CDMA800:824MHz~849MHz CDMA1900:1850MHz~1910MHz
Batteries used in testing	Li-Lon/XP3.20-0001100/Sunwoda Electronic Co., Ltd
Charger	DSA-3PFC-05 FEU 050065/DEE VAN ENTERPRISE CO., LTD
S/W Version	E343B_1200B03
H/W Version	A
State of sample	Production Unit
MEID	A100001290A090
Notes	---

1.6 summary of T-coil results

1.6.1 T-coil coupling field intensity

1.6.1.1 Axial Field Intensity

Band & Mode	Minimum limit [dB(A/m)]	Minimum Result [dB(A/m)]	Verdict
CDMA800	≥ -18	-0.818	PASS
CDMA1900	≥ -18	-1.603	PASS

1.6.1.2 Radial Field Intensity

Band & Mode	Minimum limit [dB(A/m)]	Minimum Result [dB(A/m)]	Verdict
CDMA800	≥ -18	-16.44	Pass
CDMA1900	≥ -18	-17.53	Pass

1.6.2 Frequency Response at Axial Measurement Point

Band & Mode	Verdict
CDMA800	pass
CDMA1900	pass

1.6.3 Signal Quality

Mode	Minimum result [dB]	Category assessment
CDMA800	23.10	T3
CDMA1900	20.56	T3

2. EUT Description

Modes of operation	Bands	Modulation mode	Duty cycle
CDMA	800	OQPSK	1
CDMA	1900	OQPSK	1

2.1 picture of Device

See HAC RF Emissions Test Report ‘SRTC2011-HAC004-E0003’

3. Test conditions

3.1 Temperature and Humidity

Ambient temperature [°C]	21.0 to 23.0
Ambient humidity[RH %]	32 to 39

3.2 Test Signal, Frequencies, and Output Power

The transmitter of the device was put into operation by using a call tester .communications between the device and the call tester were established by air link. Speech coding was processed with EFR speech codec for CDMA.

For all tests the device output power was set to maximum power level; a fully charged battery was used for every test sequence.

The measurements were performed on low, middle, high channels.

3.3 WD Parameters

HAC mode was switched on from the WD user interface, volume setting was set to maximum and Microphone was muted.

4. Description of the test equipment

4.1 Measurement system and components

The measurements were performed using an automated near-field scanning system, DASY4, soft version 4.7 manufactured by Schmid & Partner Engineering AG (SPEAG) in Switzerland .

Components and signal paths of used measurement system are pictured below:

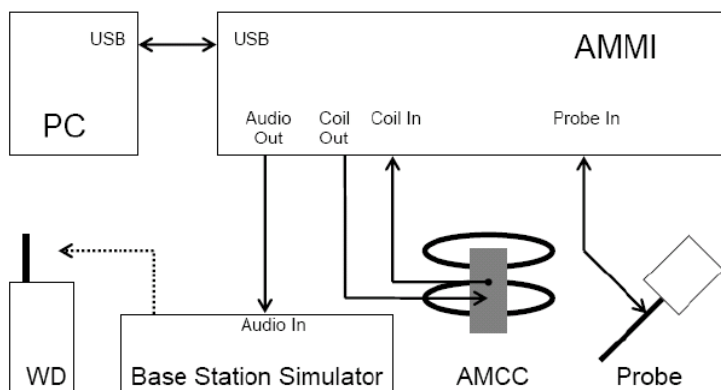

The following table lists calibration dates of SPEAG components:

Test equipment	Serial number	Calibration interval	Calibration expiry
DAE 4	720	12months	2012.01.19
R&S CMU200 Radio Communication Test Set	114666	12months	2011.08.20
AM1DV2 Audio Magnetic Probe	1050	12months	2011.08.19
AMMI Audio Magnetic Measurement Instrument	1045	-	-
AMCC Helmholtz Audio Magnetic Calibration Coil	1042	-	-
phantom	1080	-	-

4.1.1 Audio Magnetic Probe AM1DV2

Construction: Fully RF shielded metal construction (RF sensitivity<-100 dB)

System: Calibrated using Helmholtz coil according to manufacturers instructions

Calibration:

Frequency: 0.1-20kHz(HOX!test signal is limited to required BW of 300 to 3000Hz,ANSI C63.19);

Sensitivity <-50dB A/m

Dimensions: Overall length:290mm; Tip diameter:6mm

4.1.2 Audio Magnetic Measurement Instrument AMMI

Sampling rate: 48kHz/24bit

Dynamic Range 85dB

Test Signal generation: User selectable and predefined(via pc)

System calibration: Auto-calibration/full system calibration using AMCC with monitor output

4.1.3 Audio Magnetic calibration Coil AMCC

Dimensions 370 x 370 x 196 mm (ANSI-C63.19 compliant)

4.1.4 Device Holder

The Device Holder and Test Arch are manufactured by Speag (<http://www.dasy4.com/hac>), Test arch is used for all tests i.e. for both validation testing and device testing. The holder and test arch conforms to requirements of ANSI C63.19.

The SPEAG device holder (see section 5.1) was used to position the test device in all tests.

4.2 Verification of the System

Audio Magnetic Probe AM1D is calibrated in AMCC Helmholtz Audio Magnetic Calibration Coil

before each measurement procedure using calibration and reference signals.

R&S CMU200 audio codec and SPEAG AMMI audio paths (gain) were calibrated according to manufacturer's instructions.

5. Description of the test procedure

5.1 Test Arch and Device Holder

The test device was placed in the Device (illustrated below) that is supplied by SPEAG. Using this positioner the tested device is positioned under Test Arch.



Device holder and test Arch supplied by SPEAG

5.2 Test positions

5.2.1 Scan area centered at the acoustic output

The device was positioned such that Device Reference plane was touching the bottom of the Test Arch. The scan is centered at the acoustic output by aligning the acoustic output with the intersection of the Test Arch's middle bar and dielectric wire. The WD is positioned always this way to ensure repeatability of the measurements. Coordinate system depicted below is used to define exact locations of measurement points relative to the center of the acoustic output.

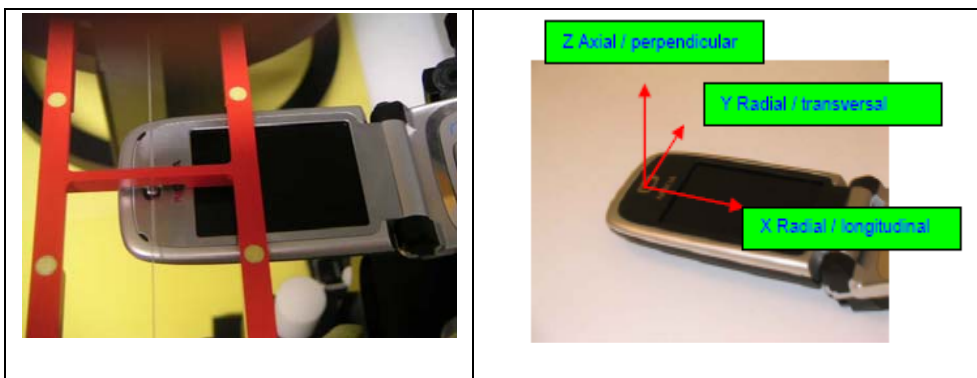

Photo of the device positioned under Test Arch and coordinate system (The EUT in picture is generic phone sample and does not represent the actual equipment under test)

5.3 T-coil Scan Procedures

Manufacturer can either define measurement locations for WD categorization or optimum locations can be found using following procedure; First, coarse scans in all measurement orientations, centered at the earpiece, are made to find approximate

locations of optimum signal. More accurate fine scans are made in these locations to find final measurement points.

5.4 Measurement procedure and used test signals

During measurements signal is fed to WD via communication tester. Proper gain setting is used in software to ensure correct signal level fed to communication tester speech input. Measurement software compares fed signal and signal from measurement probe and applies proper filtering and integration procedures.

Broadband voice-like signal (300...3000Hz) is used during scans and frequency response measurement to ensure proper operation of WD vocoder and audio enhancement algorithms.

Both signal (ABM1) and undesired audio noise (ABM2) are measured consequently to enable determination of signal+noise to noise ratio (SNR).

In final measurement sine signal is used to determine signal strength @ 1025 Hz.

5.5 T-coil Requirements and Category Limits

RF Emissions

Wireless device has to fulfill RF emission requirements at the axial measurement location.

Axial Field Intensity

The axial component of the magnetic field shall be $\geq -18\text{dB(A/m)}$ at 1 kHz, in 1/3 octave band filter.

Radial Field Intensity

The radial components of the magnetic field shall be $\geq -18\text{dB(A/m)}$ at 1 kHz, in 1/3 octave band filter.

Signal Quality

The worst result of three T-coil signal measurements is used to define WD Hearing Aid T-category according to the category limits:

Category	Telephone parameters WD signal quality [(signal + noise)-to-noise ratio in decibels]
Category T1	0 dB to 10 dB
Category T2	10 dB to 20 dB
Category T3	20 dB to 30 dB
Category T4	> 30 dB

Frequency Response

Frequency response of the axial component must be between the limits pointed by frequency curves below:

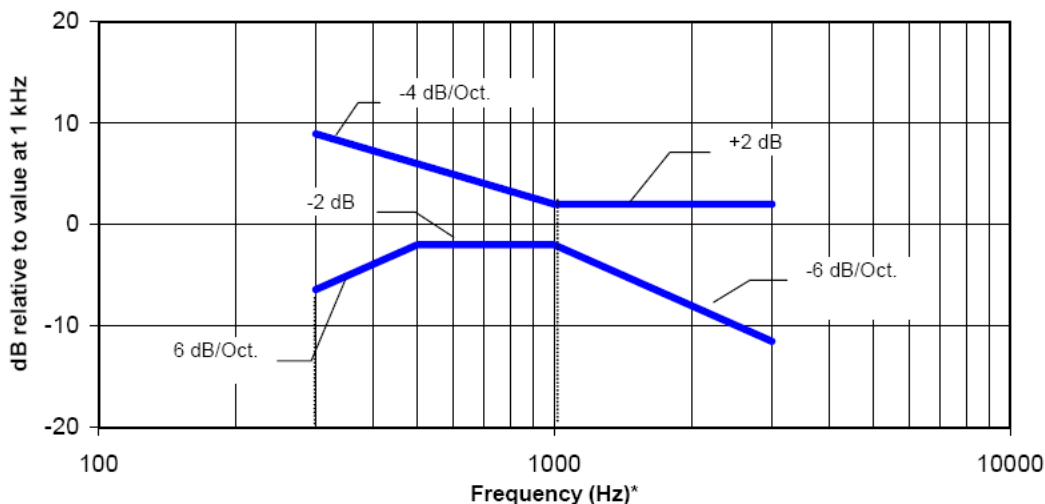

NOTE—Frequency response is between 300 Hz and 3000 Hz.

Magnetic field frequency response for WDs with a field ≤ -15 dB (A/m) at 1 kHz

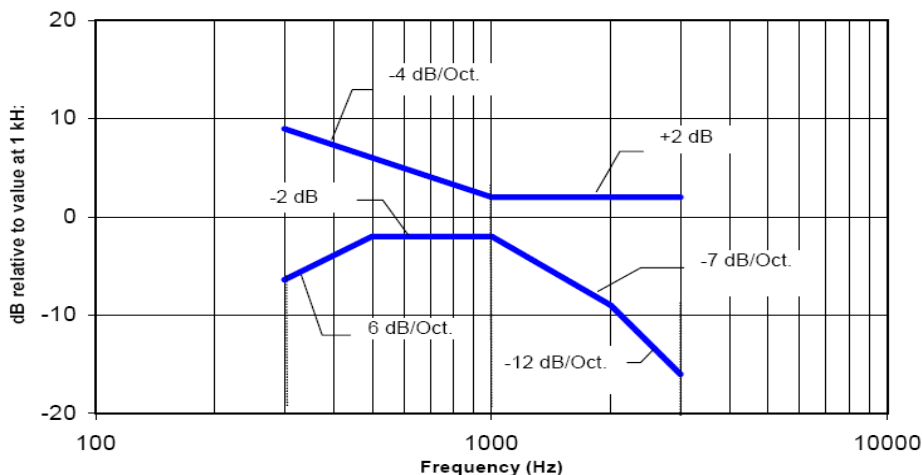

NOTE—Frequency response is between 300 Hz and 3000 Hz.

Magnetic field frequency response for WDs with a field that exceeds -15 dB(A/m) at 1 kHz

6. Measurement uncertainty

Source of uncertainty	Tolerance ±%	Probability Distribution	Div.	C_i ABM1	C_i ABM2	Std.Unc. ±%, ABM1	Std.Unc. ±%, ABM2
Measurement system							
Probe sensitivity reference level	3.0	N	1	1	1	3.0	3.0
AMCC geometry	0.4	R	$\sqrt{3}$	1	1	0.2	0.2
AMCC current	0.6	R	$\sqrt{3}$	1	1	0.4	0.4
Probe positioning during calibration	0.1	R	$\sqrt{3}$	1	1	0.1	0.1
Noise contribution	0.7	R	$\sqrt{3}$	0.0143	1	0.0	0.4
Frequency slope	5.9	R	$\sqrt{3}$	0.1	1.0	0.3	3.5
PROBE SYSTEM							
Repeatability / Drift	1.0	R	$\sqrt{3}$	1	1	0.6	0.6
Linearity / Dynamic range	0.6	R	$\sqrt{3}$	1	1	0.4	0.4
Acoustic noise	1.0	R	$\sqrt{3}$	0.1	1	0.1	0.6
Probe angle	2.3	R	$\sqrt{3}$	1	1	1.4	1.4
Spectral processing	0.9	R	$\sqrt{3}$	1	1	0.5	0.5
Integration time	0.6	N	1.0	1	5	0.6	3.0
Field disturbance	0.2	R	$\sqrt{3}$	1	1	0.1	0.1
Test signal							
Reference signal spectral response	0.6	R	$\sqrt{3}$	0	1	0.0	0.4
POSITIONING							
Probe positioning	1.9	R	$\sqrt{3}$	1	1	1.1	1.1
Phantom thickness	0.9	R	$\sqrt{3}$	1	1	0.5	0.5
EUT Positioning	1.9	R	$\sqrt{3}$	1	1	1.1	1.1
EXTERNAL CONTRIBUTIONS							
RF interference	0.0	R	$\sqrt{3}$	1	1	0.0	0.0
Test signal variation	2.0	R	$\sqrt{3}$	1	1	1.2	1.2
Combined uncertainty						4.1	6.1
Combined Standard Uncertainty (ABM field)							
Expanded std. uncertainty [%]						8.1	12.3

7. Results

Measurement location coordinates are defined as deviation from earpiece center in millimeters. Coordinate system is defined in chapter 4.2

Axial measurement location was defined by the manufacturer of the device as the center of the earpiece. Maximum values for axial field are listed for informative purposes although results at earpiece center were used in evaluating T-category of the device.

Band	channel	Probe position	Measurement location (x,y) [mm]	Ambient noise [dB A/m]	ABM2 [dB A/m]	ABM1 [dB A/m]	SNR[dB]
CDMA 800	1013	Axial (Z)	-2,10.3	-59.0	-31.76	0.136	31.89
		Radial 1 (X)	-12.5,14.5	-59.5	-36.74	-9.009	27.73
		Radial 2 (Y)	-6.2,4.2	-59.6	-56.36	-16.44	39.92
	384	Axial (Z)	-4.2,10.3	-59.0	-32.21	-0.818	31.40
		Radial 1 (X)	-10.5,8.3	-59.5	-35.85	-12.75	23.1
		Radial 2 (Y)	-4.2,4.2	-59.6	-57.69	-13.88	43.81
	777	Axial (Z)	-2,8.5	-59.0	-31.15	1.048	32.2
		Radial 1 (X)	-8.5,8.3	-59.5	-35.4	-7.806	27.59
		Radial 2 (Y)	-2,4.2	-59.6	-56.42	-10.24	46.18
CDMA 1900	25	Axial (Z)	-6.2,6.3	-58.77	-29.5	-1.603	30.14
		Radial 1 (X)	-10.5,8.5	-59.50	-34.46	-9.543	24.91
		Radial 2 (Y)	-4.2,4.2	-59.28	-57.81	-17.53	40.29
	600	Axial (Z)	-6.2,10.3	-58.77	-31.7	-1.199	30.5
		Radial 1 (X)	-10.5,12.3	-59.50	-34.12	-13.55	20.56
		Radial 2 (Y)	-4.3,4.2	-59.28	-56.26	-15.05	41.22
	1175	Axial (Z)	--2.2,10.3	-58.77	-29.93	-0.408	29.52
		Radial 1 (X)	-12.5,10.3	-59.50	-34.02	-9.765	24.26
		Radial 2 (Y)	-8.2,4.2	-59.28	-58.95	-13.1	45.85

Plots of the signal strength measurement scans are presented in Appendix A.

APPENDIX A: MEASUREMENT SCAN

Axial Measurements, CDMA800

Communication System: cdma 835; Frequency: 836.52 MHz; Duty Cycle: 1:1

Medium parameters used: $\sigma = 0$ mho/m, $\epsilon_r = 1$; $\rho = 1$ kg/m³

Phantom section: TCoil Section

DASY4 Configuration:

- Probe: AM1DV2 - 1050; ; Calibrated: 8/19/2010
- Sensor-Surface: 0mm (Fix Surface)
- Electronics: DAE - SN720; Calibrated: 1/19/2011
- Phantom: HAC Test Arch with AMCC; Type: SD HAC P01 BA; Serial: 1080
- Measurement SW: DASY4, V4.7 Build 80; Post processing SW: SEMCAD, V1.8 Build 186

General Scans MID/z (axial) fine 2mm 8 x 8/ABM SNR(x, y, z)

(5x5x1):

Cursor:

ABM1/ABM2 = 31.4 dB

ABM1 comp = -0.818 dB A/m

BWC Factor = 0.166978 dB

Location: -4.2, 10.3, 3.7 mm

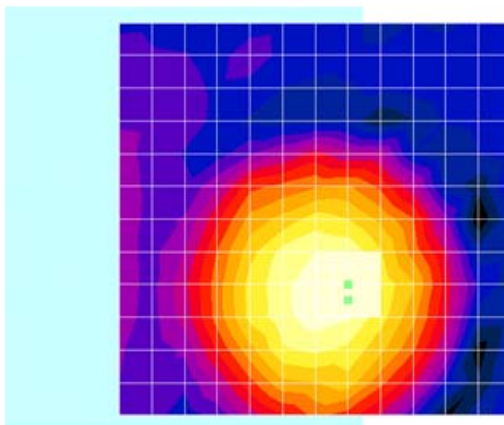
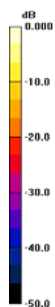

Frequency response over earpiece, (axial)

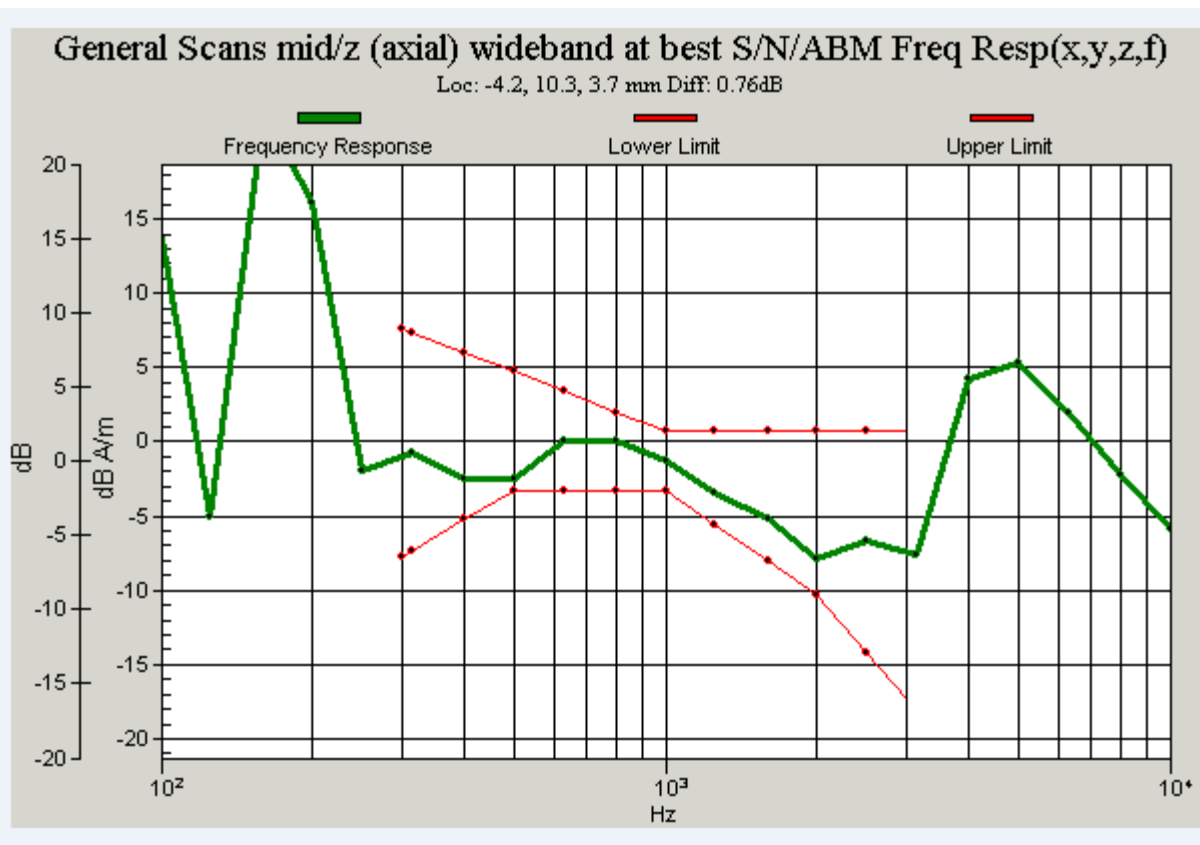

Radial1 Measurements, CDMA800

Communication System: cdma 835; Frequency: 836.52 MHz; Duty Cycle: 1:1

Medium parameters used: $\sigma = 0$ mho/m, $\epsilon_r = 1$; $\rho = 1$ kg/m³

Phantom section: TCoil Section

DASY4 Configuration:

- Probe: AM1DV2 - 1050; ; Calibrated: 8/19/2010
- Sensor-Surface: 0mm (Fix Surface)
- Electronics: DAE - SN720; Calibrated: 1/19/2011
- Phantom: HAC Test Arch with AMCC; Type: SD HAC P01 BA; Serial: 1080
- Measurement SW: DASY4, V4.7 Build 80; Postprocessing SW: SEMCAD, V1.8 Build 186

General Scans MID/x (longitudinal) fine 2mm 8 x 8/ABM

SNR(x, y, z) (5x5x1):

Cursor:

ABM1/ABM2 = 23.1 dB

ABM1 comp = -12.8 dB A/m

BWC Factor = 0.166978 dB

Location: -10.5, 8.3, 3.7 mm

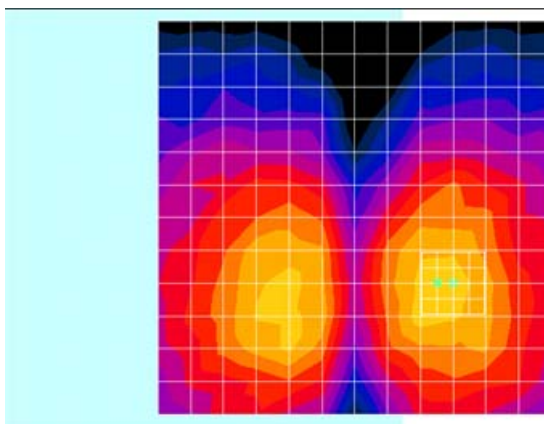
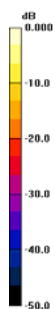

Radial2 Measurements, CDMA800

Communication System: cdma 835; Frequency: 836.52 MHz;Duty Cycle: 1:1

Medium parameters used: $\sigma = 0$ mho/m, $\epsilon_r = 1$; $\rho = 1$ kg/m³

Phantom section: TCoil Section

DASY4 Configuration:

- Probe: AM1DV2 - 1050; ; Calibrated: 8/19/2010
- Sensor-Surface: 0mm (Fix Surface)
- Electronics: DAE - SN720; Calibrated: 1/19/2011
- Phantom: HAC Test Arch with AMCC; Type: SD HAC P01 BA; Serial: 1080
- Measurement SW: DASY4, V4. 7 Build 80; Postprocessing SW: SEMCAD, V1. 8 Build 186

General Scans MID/Y (longitudinal) fine 2mm 8 x 8/ABM

SNR(x, y, z) (5x5x1):

Cursor:

ABM1/ABM2 = 43.8 dB

ABM1 comp = -13.9 dB A/m

BWC Factor = 0.166978 dB

Location: -4.2, 4.2, 3.7 mm

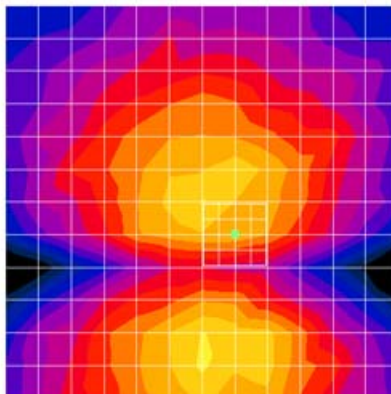
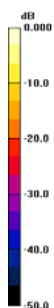

Axial Measurements, CDMA800

Communication System: cdma 835; Frequency: 824.7 MHz; Duty Cycle: 1:1

Medium parameters used: $\sigma = 0$ mho/m, $\epsilon_r = 1$; $\rho = 1$ kg/m³

Phantom section: TCoil Section

DASY4 Configuration:

- Probe: AM1DV2 - 1050; ; Calibrated: 8/19/2010
- Sensor-Surface: 0mm (Fix Surface)
- Electronics: DAE - SN720; Calibrated: 1/19/2011
- Phantom: HAC Test Arch with AMCC; Type: SD HAC P01 BA; Serial: 1080
- Measurement SW: DASY4, V4.7 Build 80; Postprocessing SW: SEMCAD, V1.8 Build 186

General Scans low/z (axial) fine 2mm 8 x 8/ABM SNR(x, y, z)

(5x5x1):

Cursor:

ABM1/ABM2 = 31.9 dB

ABM1 comp = 0.136 dB A/m

BWC Factor = 0.155979 dB

Location: -2, 10.3, 3.7 mm

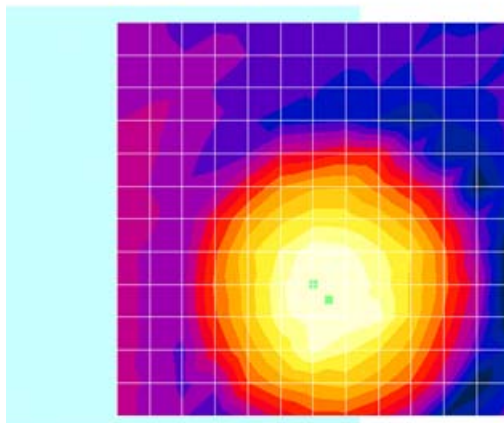
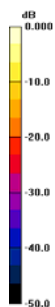

Frequency response over earpiece, (axial)

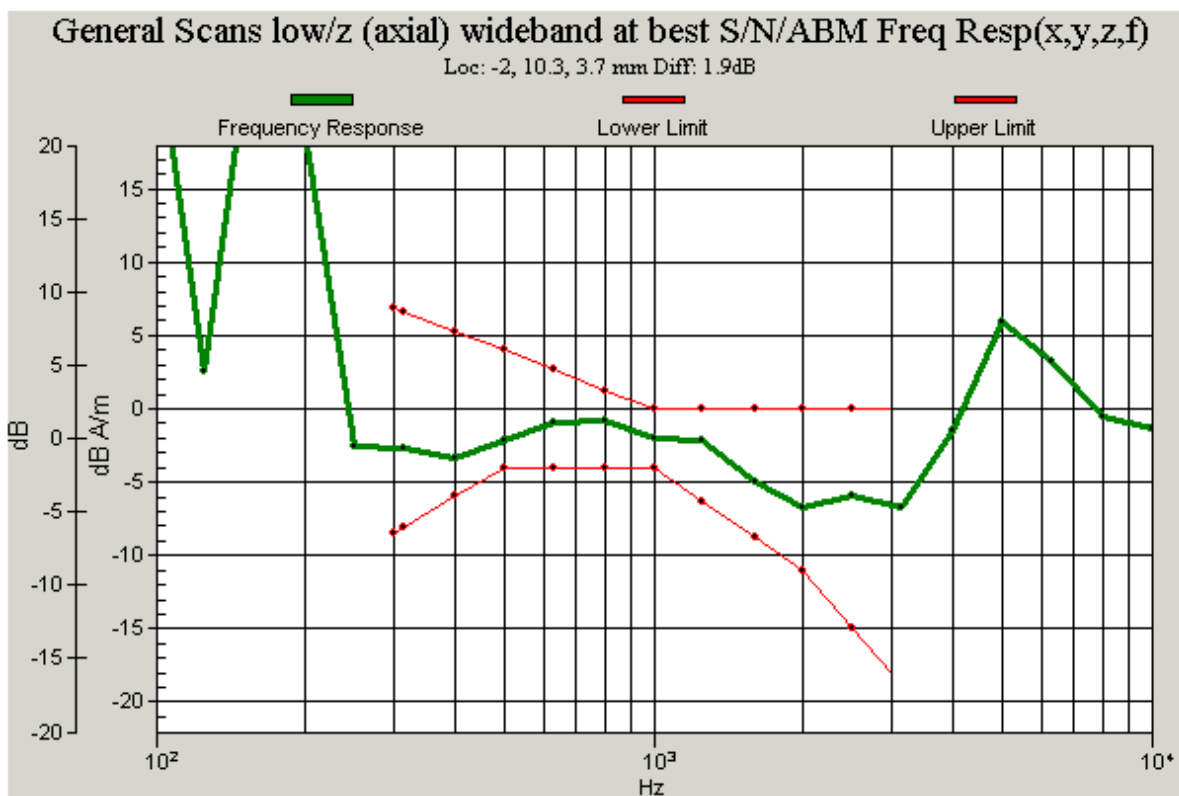

Radial1 Measurements, CDMA800

Communication System: cdma 835; Frequency: 824.7 MHz; Duty Cycle: 1:1

Medium parameters used: $\sigma = 0$ mho/m, $\epsilon_r = 1$; $\rho = 1$ kg/m³

Phantom section: TCoil Section

DASY4 Configuration:

- Probe: AM1DV2 - 1050; ; Calibrated: 8/19/2010
- Sensor-Surface: 0mm (Fix Surface)
- Electronics: DAE - SN720; Calibrated: 1/19/2011
- Phantom: HAC Test Arch with AMCC; Type: SD HAC P01 BA; Serial: 1080
- Measurement SW: DASY4, V4.7 Build 80; Postprocessing SW: SEMCAD, V1.8 Build 186

General Scans low/x (longitudinal) fine 2mm 8 x 8/ABM SNR(x,y,z) (5x5x1):

Cursor:

ABM1/ABM2 = 27.7 dB

ABM1 comp = -9.01 dB A/m

BWC Factor = 0.155979 dB

Location: -12.5, 14.5, 3.7 mm

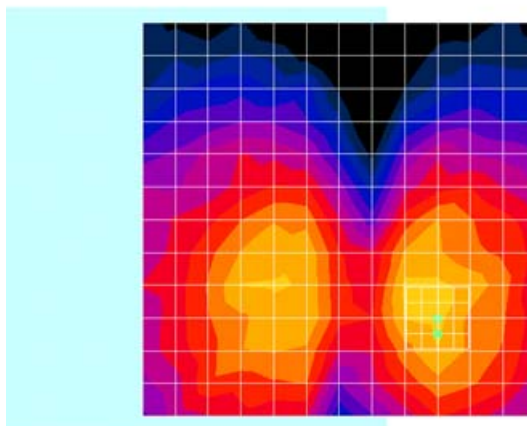
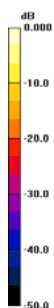

Radial2 Measurements, CDMA800

Communication System: cdma 835; Frequency: 824.7 MHz; Duty Cycle: 1:1

Medium parameters used: $\sigma = 0$ mho/m, $\epsilon_r = 1$; $\rho = 1$ kg/m³

Phantom section: TCoil Section

DASY4 Configuration:

- Probe: AM1DV2 - 1050; ; Calibrated: 8/19/2010
- Sensor-Surface: 0mm (Fix Surface)
- Electronics: DAE - SN720; Calibrated: 1/19/2011
- Phantom: HAC Test Arch with AMCC; Type: SD HAC P01 BA; Serial: 1080
- Measurement SW: DASY4, V4.7 Build 80; Postprocessing SW: SEMCAD, V1.8 Build 186

General Scans low/y (transversal) fine 2mm 8 x 8/ABM SNR(x,y,z) (5x5x1):

Cursor:

ABM1/ABM2 = 39.9 dB

ABM1 comp = -16.4 dB A/m

BWC Factor = 0.155979 dB

Location: -6.2, 4.2, 3.7 mm

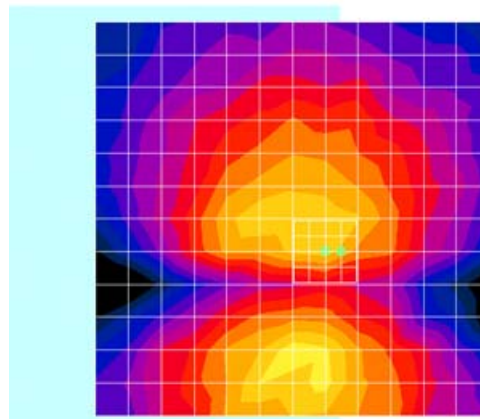
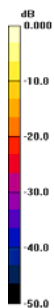

Axial Measurements,CDMA800

Communication System: cdma 835; Frequency: 848.3 MHz;Duty Cycle: 1:1

Medium parameters used: $\sigma = 0$ mho/m, $\epsilon_r = 1$; $\rho = 1$ kg/m³

Phantom section: TCoil Section

DASY4 Configuration:

- Probe: AM1DV2 - 1050; ; Calibrated: 8/19/2010
- Sensor-Surface: 0mm (Fix Surface)
- Electronics: DAE - SN720; Calibrated: 1/19/2011
- Phantom: HAC Test Arch with AMCC; Type: SD HAC P01 BA; Serial: 1080
- Measurement SW: DASY4, V4. 7 Build 80; Postprocessing SW: SEMCAD, V1. 8 Build 186

General Scans high/z (axial) fine 2mm 8 x 8/ABM SNR(x, y, z)

(5x5x1):

Cursor:

ABM1/ABM2 = 32.2 dB

ABM1 comp = 1.05 dB A/m

BWC Factor = 0.16604 dB

Location: -2, 8.5, 3.7 mm

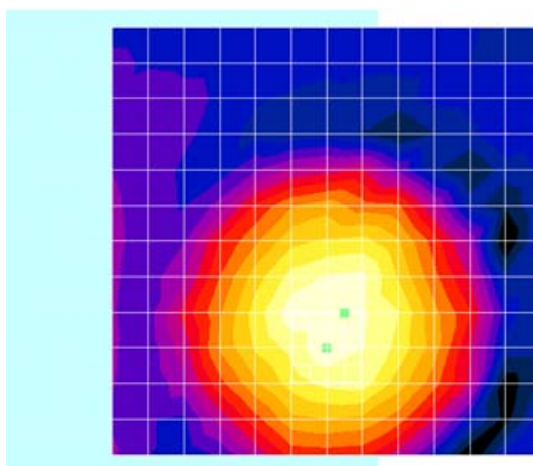
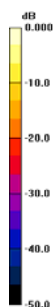

Frequency response over earpiece, (axial)

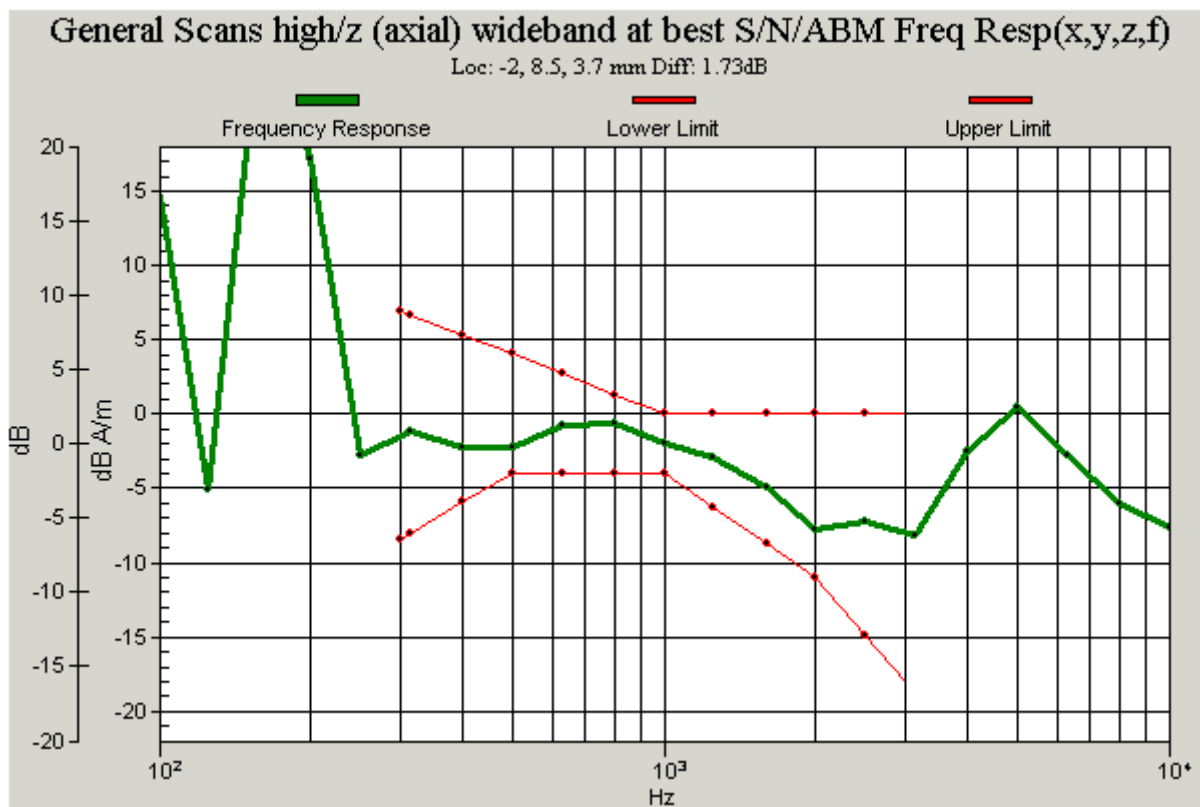

Radial1 Measurements, CDMA800

Communication System: cdma 835; Frequency: 848.3 MHz;Duty Cycle: 1:1

Medium parameters used: $\sigma = 0$ mho/m, $\epsilon_r = 1$; $\rho = 1$ kg/m³

Phantom section: TCoil Section

DASY4 Configuration:

- Probe: AM1DV2 - 1050; ; Calibrated: 8/19/2010
- Sensor-Surface: 0mm (Fix Surface)
- Electronics: DAE - SN720; Calibrated: 1/19/2011
- Phantom: HAC Test Arch with AMCC; Type: SD HAC P01 BA; Serial: 1080
- Measurement SW: DASY4, V4.7 Build 80; Postprocessing SW: SEMCAD, V1.8 Build 186

General Scans high/x (longitudinal) fine 2mm 8 x 8/ABM SNR(x,y,z) (5x5x1):

Cursor:

ABM1/ABM2 = 27.6 dB

ABM1 comp = -7.81 dB A/m

BWC Factor = 0.16604 dB

Location: -8.5, 8.3, 3.7 mm

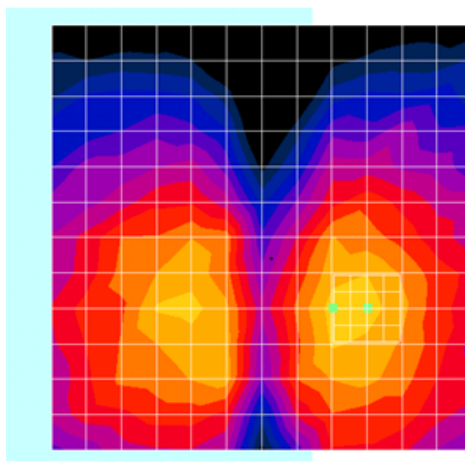
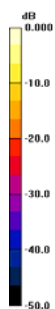

Radial2 Measurements, CDMA800

Communication System: cdma 835; Frequency: 848.3 MHz; Duty Cycle: 1:1

Medium parameters used: $\sigma = 0$ mho/m, $\epsilon_r = 1$; $\rho = 1$ kg/m³

Phantom section: TCoil Section

DASY4 Configuration:

- Probe: AM1DV2 - 1050; ; Calibrated: 8/19/2010
- Sensor-Surface: 0mm (Fix Surface)
- Electronics: DAE - SN720; Calibrated: 1/19/2011
- Phantom: HAC Test Arch with AMCC; Type: SD HAC P01 BA; Serial: 1080
- Measurement SW: DASY4, V4.7 Build 80; Postprocessing SW: SEMCAD, V1.8 Build 186

General Scans high/y (transversal) fine 2mm 8 x 8/ABM SNR(x,y,z) (5x5x1):

Cursor:

ABM1/ABM2 = 46.2 dB

ABM1 comp = -10.2 dB A/m

BWC Factor = 0.16604 dB

Location: -2, 4.2, 3.7 mm

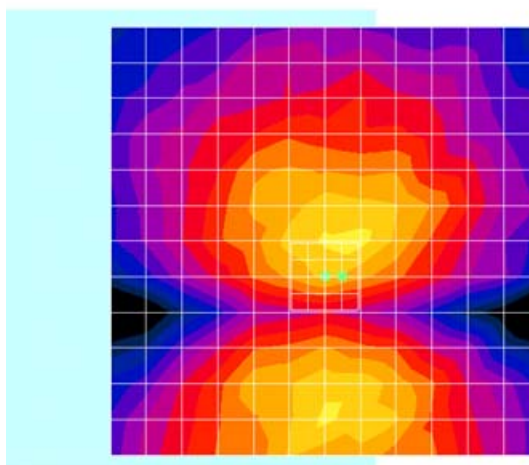
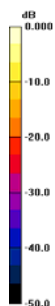

Axial Measurements, CDMA1900

Communication System: cdma PCS (2000 ,1900); Frequency: 1880 MHz;Duty Cycle: 1:1

Medium parameters used: $\sigma = 0$ mho/m, $\epsilon_r = 1$; $\rho = 1$ kg/m³

Phantom section: TCoil Section

DASY4 Configuration:

- Probe: AM1DV2 - 1050; ; Calibrated: 8/19/2010
- Sensor-Surface: 0mm (Fix Surface)
- Electronics: DAE - SN720; Calibrated: 1/19/2011
- Phantom: HAC Test Arch with AMCC; Type: SD HAC P01 BA; Serial: 1080
- Measurement SW: DASY4, V4.7 Build 80; Postprocessing SW: SEMCAD, V1.8 Build 186

General Scans mid/z (axial) fine 2mm 8 x 8/ABM SNR(x, y, z)

(5x5x1):

Cursor:

ABM1/ABM2 = 30.5 dB

ABM1 comp = -1.20 dB A/m

BWC Factor = 0.159988 dB

Location: -6.2, 10.3, 3.7 mm

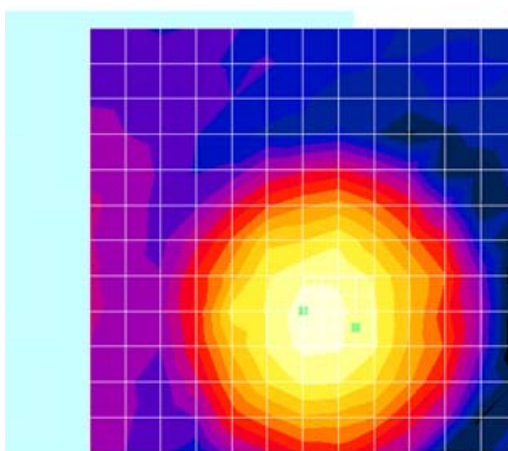
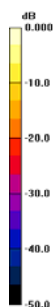

Frequency response over earpiece, (axial)

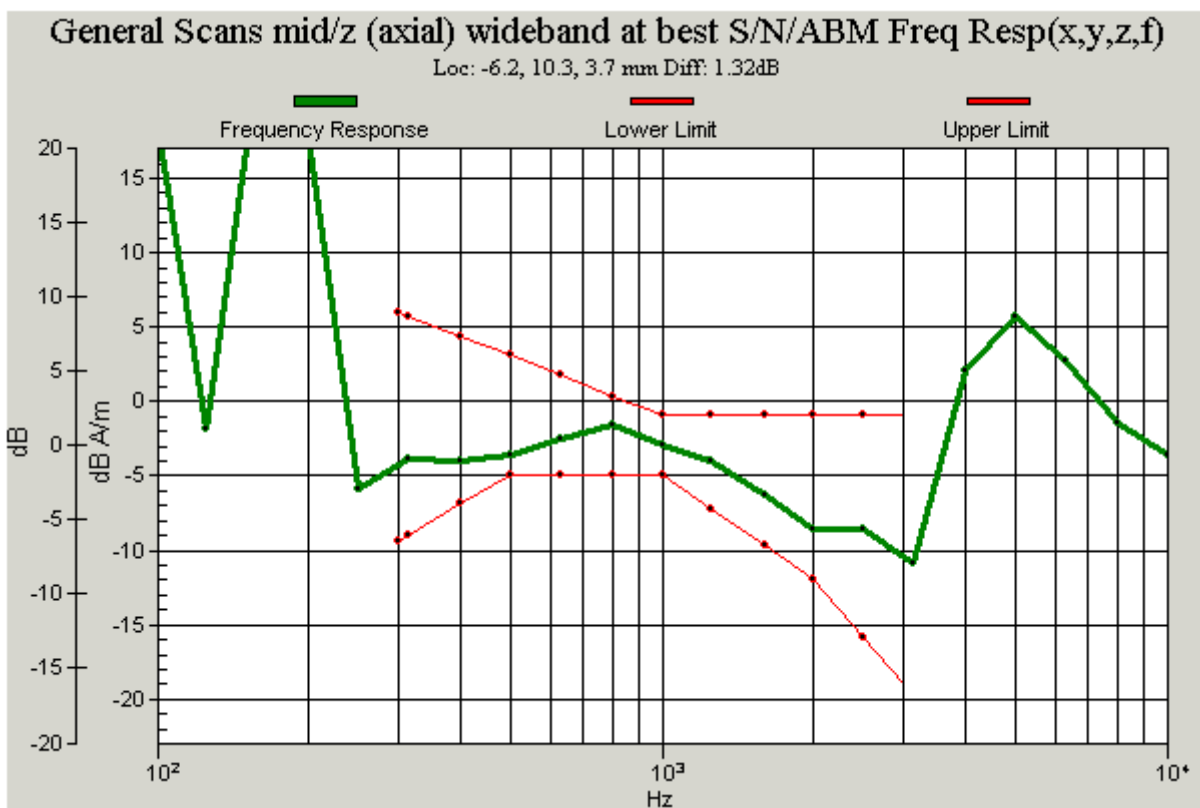

Radial1 Measurements, CDMA1900

Communication System: cdma PCS (2000 ,1900); Frequency: 1880 MHz;Duty Cycle: 1:1

Medium parameters used: $\sigma = 0$ mho/m, $\epsilon_r = 1$; $\rho = 1$ kg/m³

Phantom section: TCoil Section

DASY4 Configuration:

- Probe: AM1DV2 - 1050; ; Calibrated: 8/19/2010
- Sensor-Surface: 0mm (Fix Surface)
- Electronics: DAE - SN720; Calibrated: 1/19/2011
- Phantom: HAC Test Arch with AMCC; Type: SD HAC P01 BA; Serial: 1080
- Measurement SW: DASY4, V4. 7 Build 80; Postprocessing SW: SEMCAD, V1. 8 Build 186

General Scans mid/x (longitudinal) fine 2mm 8 x 8/ABM SNR(x,y,z) (5x5x1):

Cursor:

ABM1/ABM2 = 20.6 dB

ABM1 comp = -13.6 dB A/m

BWC Factor = 0.159988 dB

Location: -10.5, 12.3, 3.7 mm

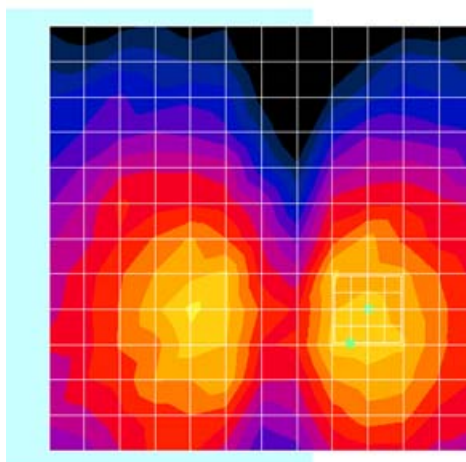
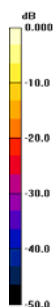

Radial2 Measurements, CDMA1900

Communication System: cdma PCS (2000 ,1900); Frequency: 1880 MHz;Duty Cycle: 1:1

Medium parameters used: $\sigma = 0$ mho/m, $\epsilon_r = 1$; $\rho = 1$ kg/m³

Phantom section: TCoil Section

DASY4 Configuration:

- Probe: AM1DV2 - 1050; ; Calibrated: 8/19/2010
- Sensor-Surface: 0mm (Fix Surface)
- Electronics: DAE - SN720; Calibrated: 1/19/2011
- Phantom: HAC Test Arch with AMCC; Type: SD HAC P01 BA; Serial: 1080
- Measurement SW: DASY4, V4.7 Build 80; Postprocessing SW: SEMCAD, V1.8 Build 186

General Scans mid/y (transversal) fine 2mm 8 x 8/ABM SNR(x,y,z) (5x5x1):

Cursor:

ABM1/ABM2 = 41.2 dB

ABM1 comp = -15.0 dB A/m

BWC Factor = 0.159988 dB

Location: -4.3, 4.2, 3.7 mm

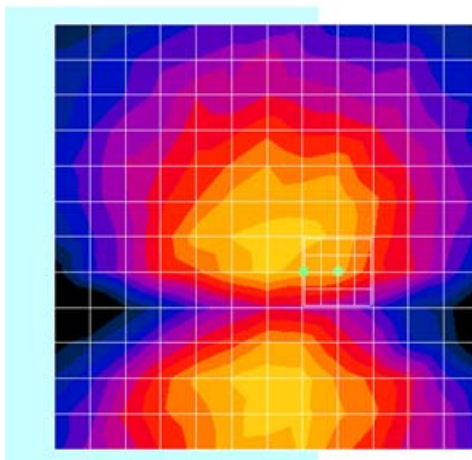
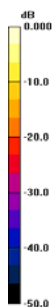

Axial Measurements, CDMA1900

Communication System: cdma PCS (2000 ,1900); Frequency: 1851.25 MHz;Duty Cycle: 1:1
 Medium parameters used: $\sigma = 0$ mho/m, $\epsilon_r = 1$; $\rho = 1$ kg/m³
 Phantom section: TCoil Section

DASY4 Configuration:

- Probe: AM1DV2 - 1050; ; Calibrated: 8/19/2010
- Sensor-Surface: 0mm (Fix Surface)
- Electronics: DAE - SN720; Calibrated: 1/19/2011
- Phantom: HAC Test Arch with AMCC; Type: SD HAC P01 BA; Serial: 1080
- Measurement SW: DASY4, V4.7 Build 80; Postprocessing SW: SEMCAD, V1.8 Build 186

General Scans low/z (axial) fine 2mm 8 x 8/ABM SNR(x, y, z)

(5x5x1):

Cursor:

ABM1/ABM2 = 30.1 dB
 ABM1 comp = -1.60 dB A/m
 BWC Factor = 0.155979 dB
 Location: -6.2, 6.3, 3.7 mm

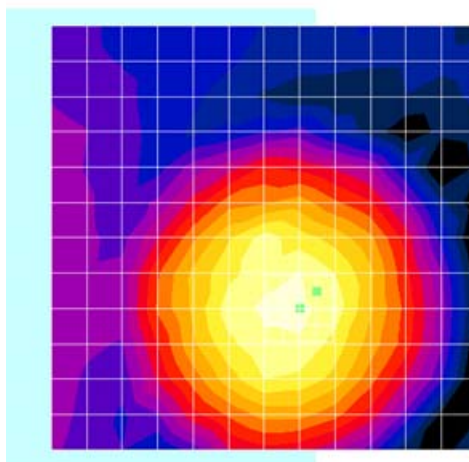
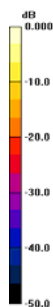

Frequency response over earpiece, (axial)

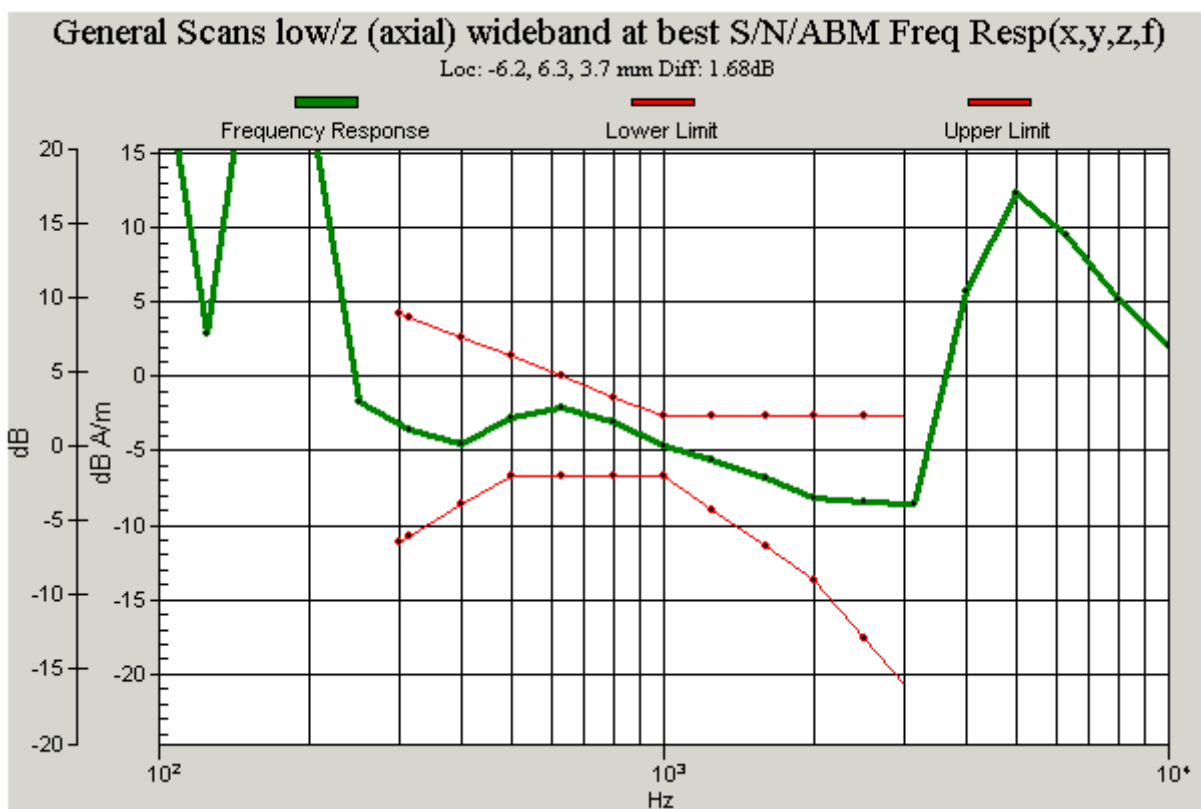

Radial1 Measurements, CDMA1900

Communication System: cdma PCS (2000 ,1900); Frequency: 1851.25 MHz;Duty Cycle: 1:1
Medium parameters used: $\sigma = 0$ mho/m, $\epsilon_r = 1$; $\rho = 1$ kg/m³
Phantom section: TCoil Section

DASY4 Configuration:

- Probe: AM1DV2 - 1050; ; Calibrated: 8/19/2010
- Sensor-Surface: 0mm (Fix Surface)
- Electronics: DAE - SN720; Calibrated: 1/19/2011
- Phantom: HAC Test Arch with AMCC; Type: SD HAC P01 BA; Serial: 1080
- Measurement SW: DASY4, V4.7 Build 80; Postprocessing SW: SEMCAD, V1.8 Build 186

General Scans low/x (longitudinal) fine 2mm 8 x 8/ABM SNR(x,y,z) (5x5x1):

Cursor:

ABM1/ABM2 = 24.9 dB

ABM1 comp = -9.54 dB A/m

BWC Factor = 0.155979 dB

Location: -10.5, 8.5, 3.7 mm

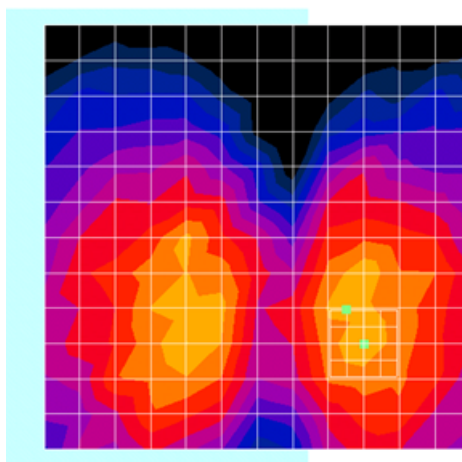
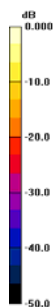

Radial2 Measurements, CDMA1900

Communication System: cdma PCS (2000 ,1900); Frequency: 1851.25 MHz;Duty Cycle: 1:1

Medium parameters used: $\sigma = 0$ mho/m, $\epsilon_r = 1$; $\rho = 1$ kg/m³

Phantom section: TCoil Section

DASY4 Configuration:

- Probe: AM1DV2 - 1050; ; Calibrated: 8/19/2010
- Sensor-Surface: 0mm (Fix Surface)
- Electronics: DAE - SN720; Calibrated: 1/19/2011
- Phantom: HAC Test Arch with AMCC; Type: SD HAC P01 BA; Serial: 1080
- Measurement SW: DASY4, V4.7 Build 80; Postprocessing SW: SEMCAD, V1.8 Build 186

General Scans low/y (transversal) fine 2mm 8 x 8/ABM SNR(x,y,z) (5x5x1):

Cursor:

ABM1/ABM2 = 40.3 dB

ABM1 comp = -17.5 dB A/m

BWC Factor = 0.155979 dB

Location: -6.2, 4.2, 3.7 mm

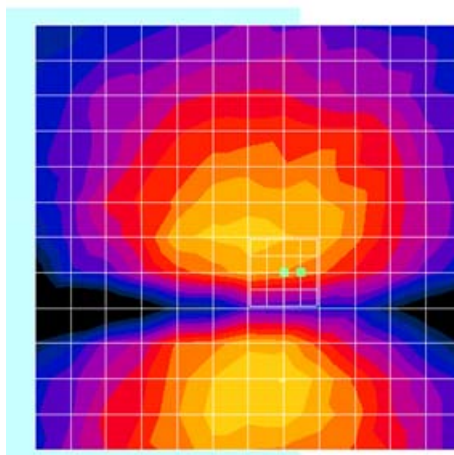
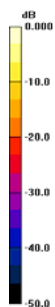

Axial Measurements, CDMA1900

Communication System: cdma PCS (2000 ,1900); Frequency: 1908.75 MHz;Duty Cycle: 1:1
 Medium parameters used: $\sigma = 0$ mho/m, $\epsilon_r = 1$; $\rho = 1$ kg/m³
 Phantom section: TCoil Section

DASY4 Configuration:

- Probe: AM1DV2 - 1050; ; Calibrated: 8/19/2010
- Sensor-Surface: 0mm (Fix Surface)
- Electronics: DAE - SN720; Calibrated: 1/19/2011
- Phantom: HAC Test Arch with AMCC; Type: SD HAC P01 BA; Serial: 1080
- Measurement SW: DASY4, V4.7 Build 80; Postprocessing SW: SEMCAD, V1.8 Build 186

General Scans high/z (axial) fine 2mm 8 x 8/ABM SNR(x,y,z) (5x5x1):

Cursor:

ABM1/ABM2 = 29.5 dB
 ABM1 comp = -0.409 dB A/m
 BWC Factor = 0.161011 dB
 Location: -2.2, 10.3, 3.7 mm

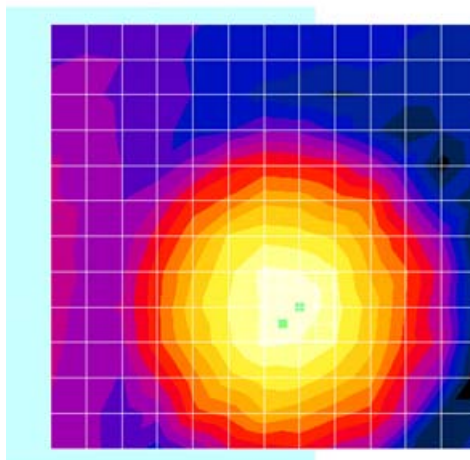
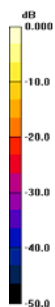

Frequency response over earpiece, (axial)

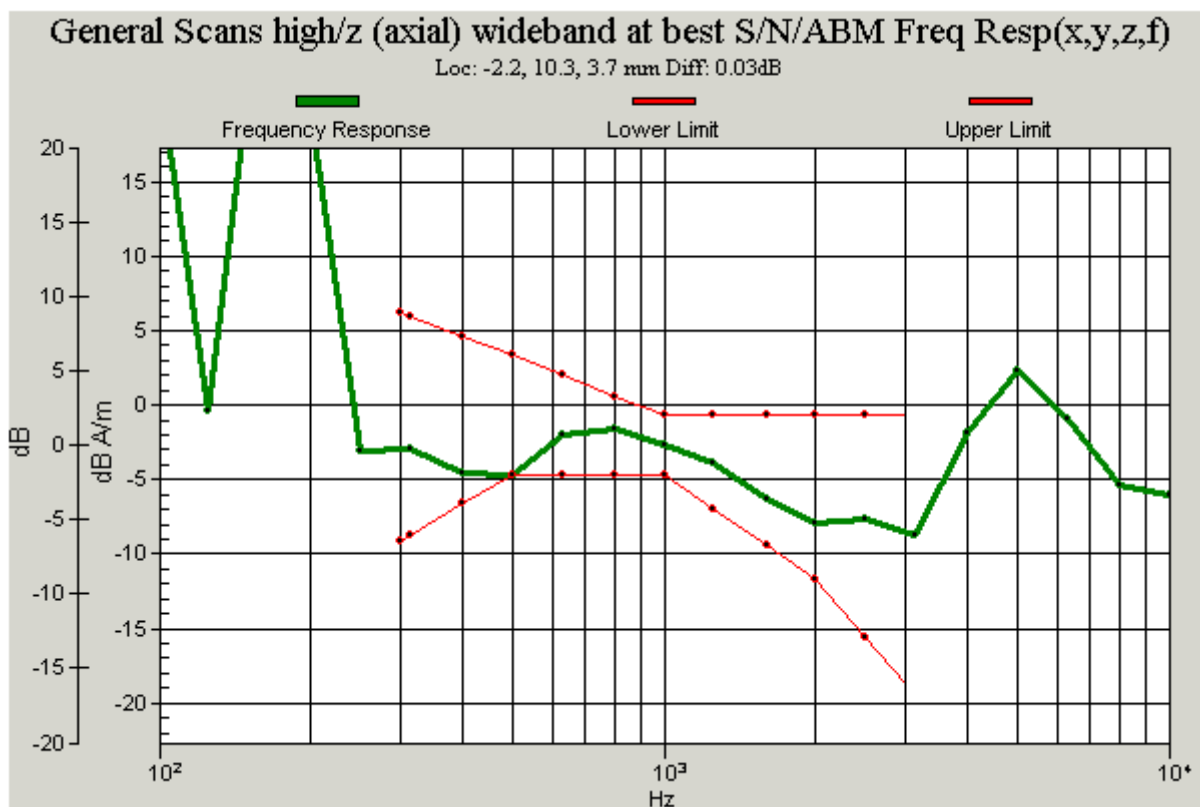

Radial1 Measurements, CDMA1900

Communication System: cdma PCS (2000 ,1900); Frequency: 1908.75 MHz;Duty Cycle: 1:1
Medium parameters used: $\sigma = 0$ mho/m, $\epsilon_r = 1$; $\rho = 1$ kg/m³
Phantom section: TCoil Section

DASY4 Configuration:

- Probe: AM1DV2 - 1050; ; Calibrated: 8/19/2010
- Sensor-Surface: 0mm (Fix Surface)
- Electronics: DAE - SN720; Calibrated: 1/19/2011
- Phantom: HAC Test Arch with AMCC; Type: SD HAC P01 BA; Serial: 1080
- Measurement SW: DASY4, V4.7 Build 80; Postprocessing SW: SEMCAD, V1.8 Build 186

General Scans high/x (longitudinal) fine 2mm 8 x 8/ABM

SNR(x, y, z) (5x5x1):

Cursor:

ABM1/ABM2 = 24.3 dB
ABM1 comp = -9.77 dB A/m
BWC Factor = 0.161011 dB
Location: -12.5, 10.3, 3.7 mm

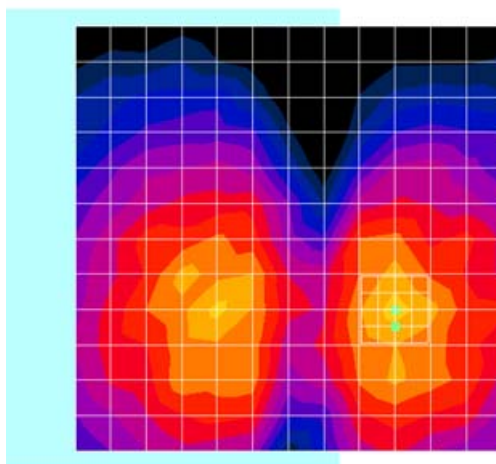
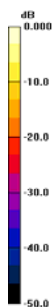

Radial2 Measurements, CDMA1900

Communication System: cdma PCS (2000 ,1900); Frequency: 1908.75 MHz;Duty Cycle: 1:1
Medium parameters used: $\sigma = 0$ mho/m, $\epsilon_r = 1$; $\rho = 1$ kg/m³
Phantom section: TCoil Section

DASY4 Configuration:

- Probe: AM1DV2 - 1050; ; Calibrated: 8/19/2010
- Sensor-Surface: 0mm (Fix Surface)
- Electronics: DAE - SN720; Calibrated: 1/19/2011
- Phantom: HAC Test Arch with AMCC; Type: SD HAC P01 BA; Serial: 1080
- Measurement SW: DASY4, V4.7 Build 80; Postprocessing SW: SEMCAD, V1.8 Build 186

General Scans high/y (transversal) fine 2mm 8 x 8/ABM

SNR(x, y, z) (5x5x1):

Cursor:

ABM1/ABM2 = 45.9 dB
ABM1 comp = -13.1 dB A/m
BWC Factor = 0.161011 dB
Location: -8.2, 4.2, 3.7 mm

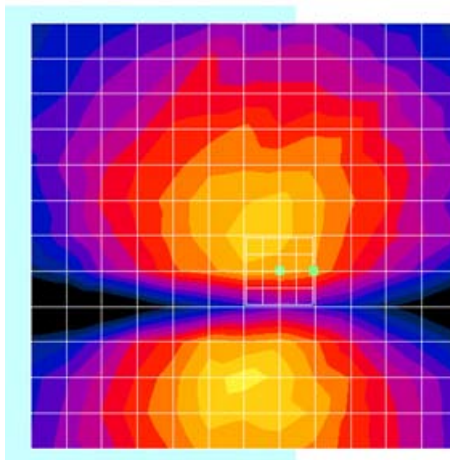
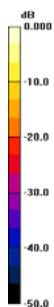

APPENDIX B: AUDIO MAGNETIC AM1DV3 S/N 1050

**Calibration Laboratory of
Schmid & Partner
Engineering AG**
Zeughausstrasse 43, 8004 Zurich, Switzerland



S Schweizerischer Kalibrierdienst
C Service suisse d'étalonnage
S Servizio svizzero di taratura
S Swiss Calibration Service

Accredited by the Swiss Accreditation Service (SAS)
The Swiss Accreditation Service is one of the signatories to the EA
Multilateral Agreement for the recognition of calibration certificates
Client **Flextronics (Auden)**

Accreditation No.: **SCS 108**

Certificate No: **AM1DV2-1050_Aug10**

CALIBRATION CERTIFICATE

Object: **AM1DV2 - SN: 1050**

Calibration procedure(s): **QA CAL-24.v2
Calibration procedure for AM1D magnetic field probes and TMFS in the
audio range**

Calibration date: **August 19, 2010**

This calibration certificate documents the traceability to national standards, which realize the physical units of measurements (SI).
The measurements and the uncertainties with confidence probability are given on the following pages and are part of the certificate.

All calibrations have been conducted in the closed laboratory facility: environment temperature (22 ± 3)°C and humidity < 70%.

Calibration Equipment used (M&TE critical for calibration)

Primary Standards	ID #	Cal Date (Certificate No.)	Scheduled Calibration
Keithley Multimeter Type 2001	SN: 0810278	1-Oct-09 (No: 9055)	Oct-10
Reference Probe AM1DV2	SN: 1008	21-Jan-10 (No. AM1D-1008_Jan10)	Jan-11
DAE4	SN: 781	22-Jan-10 (No. DAE4-781_Jan10)	Jan-11
Secondary Standards	ID #	Check Date (in house)	Scheduled Check
AMCC	1050	15-Oct-09 (in house check Oct-09)	Oct-10

Calibrated by:	Name Mike Meili	Function Laboratory Technician	Signature <i>M. Meili</i>
Approved by:	Name Fin Bomholt	Function R&D Director	Signature <i>F. Bomholt</i>

Issued: August 20, 2010

This calibration certificate shall not be reproduced except in full without written approval of the laboratory.

References

- [1] ANSI C63.19-2007
American National Standard for Methods of Measurement of Compatibility between Wireless Communications Devices and Hearing Aids.
- [2] DASY4 manual, Chapter: Hearing Aid Compatibility (HAC) T-Coil Extension

Description of the AM1D probe

The AM1D Audio Magnetic Field Probe is a fully shielded magnetic field probe for the frequency range from 100 Hz to 20 kHz. The pickup coil is compliant with the dimensional requirements of [1]. The probe includes a symmetric low noise amplifier for the signal available at the shielded 3 pin connector at the side. Power is supplied via the same connector (phantom power supply) and monitored via the LED near the connector. The 7 pin connector at the end of the probe does not carry any signals, but determines the angle of the sensor when mounted on the DAE. The probe supports mechanical detection of the surface.

The single sensor in the probe is arranged in a tilt angle allowing measurement of 3 orthogonal field components when rotating the probe by 120° around its axis. It is aligned with the perpendicular component of the field, if the probe axis is tilted nominally 35.3° above the measurement plane, using the connector rotation and sensor angle stated below.

The probe is fully RF shielded when operated with the matching signal cable (shielded) and allows measurement of audio magnetic fields in the close vicinity of RF emitting wireless devices according to [1] without additional shielding.

Handling of the item

The probe is manufactured from stainless steel. In order to maintain the performance and calibration of the probe, it must not be opened. The probe is designed for operation in air and shall not be exposed to humidity or liquids. For proper operation of the surface detection and emergency stop functions in a DASY system, the probe must be operated with the special probe cup provided (larger diameter).

Methods Applied and Interpretation of Parameters

- *Coordinate System:* The AM1D probe is mounted in the DASY system for operation with a HAC Test Arch phantom with AMCC Helmholtz calibration coil according to [2], with the tip pointing to "southwest" orientation.
- *Functional Test:* The functional test preceding calibration includes test of Noise level
RF immunity (1kHz AM modulated signal). The shield of the probe cable must be well connected. Frequency response verification from 100 Hz to 10 kHz.
- *Connector Rotation:* The connector at the end of the probe does not carry any signals and is used for fixation to the DAE only. The probe is operated in the center of the AMCC Helmholtz coil using a 1 kHz magnetic field signal. Its angle is determined from the two minima at nominally +120° and -120° rotation, so the sensor in the tip of the probe is aligned to the vertical plane in z-direction, corresponding to the field maximum in the AMCC Helmholtz calibration coil.
- *Sensor Angle:* The sensor tilting in the vertical plane from the ideal vertical direction is determined from the two minima at nominally +120° and -120°. DASY system uses this angle to align the sensor for radial measurements to the x and y axis in the horizontal plane.
- *Sensitivity:* With the probe sensor aligned to the z-field in the AMCC, the output of the probe is compared to the magnetic field in the AMCC at 1 kHz. The field in the AMCC Helmholtz coil is given by the geometry and the current through the coil, which is monitored on the precision shunt resistor of the coil.

AM1D probe identification and configuration data

Item	AM1DV2 Audio Magnetic 1D Field Probe
Type No	SP AM1 001 AF
Serial No	1050

Overall length	296 mm
Tip diameter	6.0 mm (at the tip)
Sensor offset	3.0 mm (centre of sensor from tip)
Internal Amplifier	40 dB

Manufacturer / Origin	Schmid & Partner Engineering AG, Zurich, Switzerland
Manufacturing date	Apr-2007
Last calibration date	July 13, 2009

Calibration data

Connector rotation angle	(in DASY system)	135.3 °	+/- 3.6 ° (k=2)
Sensor angle	(in DASY system)	3.64 °	+/- 0.5 ° (k=2)
Sensitivity at 1 kHz	(in DASY system)	0.0654 V / (A/m)	+/- 2.2 % (k=2)