



MEASUREMENT/TECHNICAL REPORT

FCC Part 15 Subpart C

Issued: July 1, 2009

Name and Address of the Applicant:	SHIMANO INC. 3-77 Oimatu-cho, Sakai-ku, Sakai City, Osaka 590-8577, Japan
Test Item:	USB dongle
Identification:	SM-DL79
Serial No.:	---
FCC ID:	WY706
Sample Receipt Date:	January 23, 2009
Test Specification:	FCC Part 15 Subpart C, 15.249
Date of Testing:	February 9, March 31 and April 8, 2009
Test Result:	PASS

Report Prepared by:	Cosmos Corporation 2-3571 Ohnogi, Watarai-cho, Watarai-gun, Mie, Japan 516-2102 Phone: +81-596-63-0707 Fax: +81-596-63-0777
---------------------	---

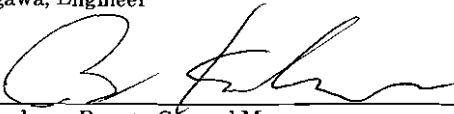
Tested by:	 O. Itogawa, Engineer	July 1, 2009 Date
Reviewed by:	 Y. Kawahara, Deputy General Manager	July 1, 2009 Date

Notes:

1. This report should not be reproduced except in full, without the written approval of Cosmos Corporation.
2. All measurement data contained in this report may have uncertainty. A judgment for the limitation should be taken into the count.
3. The report in this report apply only to the sample tested.

List of Contents	Page
1. Description of Equipment Under Test.....	3
1.1 Product Description.....	3
1.2 Antenna Description	3
1.3 Accompanied Peripherals Description	3
2. General Information	4
2.1 Test Methodology.....	4
2.2 Test Facility	4
2.3 Traceability	4
3. Summary of Test Results	4
4. Test Configuration.....	5
4.1 15. 249 (a) The field strength of emissions.....	5
4.2 15. 207 AC Power Conducted Emission.....	6
4.3 Test Mode.....	6
5. Measurement Result	7
5.1 15. 249(a) The Field Strength of Emissions	7
5.1.1 Setting Remarks	7
5.1.2 Minimum Standard	8
5.1.3 Result.....	8
5.1.4 Measured Data.....	9
5.2 15. 207 AC Power Conducted Emission	27
5.2.1 Setting Remarks	27
5.2.2 Minimum Standard	27
5.2.3 Result.....	27
5.2.4 Measured Data.....	28
5.3 15. 247(d) Band Edge Measurement	30
5.3.1 Setting Remarks	30
5.3.2 Minimum Standard	30
5.3.3 Result.....	30
5.3.4 Measured Data.....	31
5.4 15. 215 (c) 20 dB Bandwidth	32
6. Photos	33
6.1 Setup Photo (Radiated Emission).....	33
6.2 Setup Photo (Conducted Emission).....	34
7. List of Test Measurement Instruments	35
7.1 Radiated Emission Measurement.....	35
7.2 AC Power Conducted Emission Measurement	35

1. Description of Equipment Under Test

1.1 Product Description

Manufacturer : SHIMANO INC.
 Model (referred to as the EUT) : SM-DL79
 Nominal Voltage : DC 5V(PC USB terminal)
 Type of Modulation : MSK
 Mode of Operation : duplex 1/2 duplex simplex other
 The type of the equipment : Stand-alone Combined Equipment
 Plug-In Card Other (Module Unit)
 The type of the antenna : Integral external Other
 The type of power source : AC mains Dedicated AC adapter (V)
 DC Voltage Battery
 The type of battery (if applicable) : N/A
 Type of Operation : Continuous Burst Intermittent
 Stand by Mode : Available N/A
 Intended functions : PC connection
 The bandwidth of the IF filters : N/A
 Method of Communication Link : Software to PC connection
 The operating frequency band : 2402.249481 to 2480.730327MH z
 The thermal limitation : Not specified

1.2 Antenna Description

No.	Type Name	Gain	Antenna Type	Remarks
1	2.4GHz chip antenna	Less than +1dBi	Helical antenna	The product by "TAIYO YUDEN"

1.3 Accompanied Peripherals Description

No.	Equipment Name	Manufacturer	Type Name	Serial Number	Remarks
1	PC	TOSHIBA	PSJ70N-1W401J	98100247H	DC15 V, ---, 5 A
2	AC Adapter	TOSHIBA	PA3283U-5ACA	---	AC100 V, 50/60 Hz, 1.5 A

2. General Information

2.1 Test Methodology

All measurement subject to the present report was carried out according to the procedures in ANSI C63.4: 2003.

2.2 Test Facility

All measurement was performed in the following facility;

Cosmos Corporation EMC Lab. Ohnogi

(2-3571 Ohaza-iwatachi, Ohnogi, Watarai-cho, Watarai-gun, Mie-ken 516-2102, Japan) The test firm has been filed since March 7, 2008 under CFR 47 Part.2.948.

2.3 Traceability

The calibration of measurement equipment used in the test subject to the present report is designed and operated to ensure that the measurement is traceable to national standards of measurement or equivalent abroad.

3. Summary of Test Results

Section	Test Item	Limit	Result
15. 207	AC Power Conducted Emission	See 5.2.2	Pass
15. 215 (c)	20 dB Bandwidth	---	Pass
15. 247 (d)	Band Edge Measurement	See 5.3.2	Pass
15. 249 (a)	The Field Strength of Emissions	See 5.1.2	Pass

4. Test Configuration

	Instrument	Model	Cable	Length	Shield
A	EUT	SM-DL79	a AC Power Cable	0.8 m	×
B	PC	PSJ70N-1W401J	b DC Power Cable	1.5 m	×
C	AC Adapter	PA3283U-5ACA	c USB Cable	1.5 m	○

4.1 15. 249 (a) The field strength of emissions

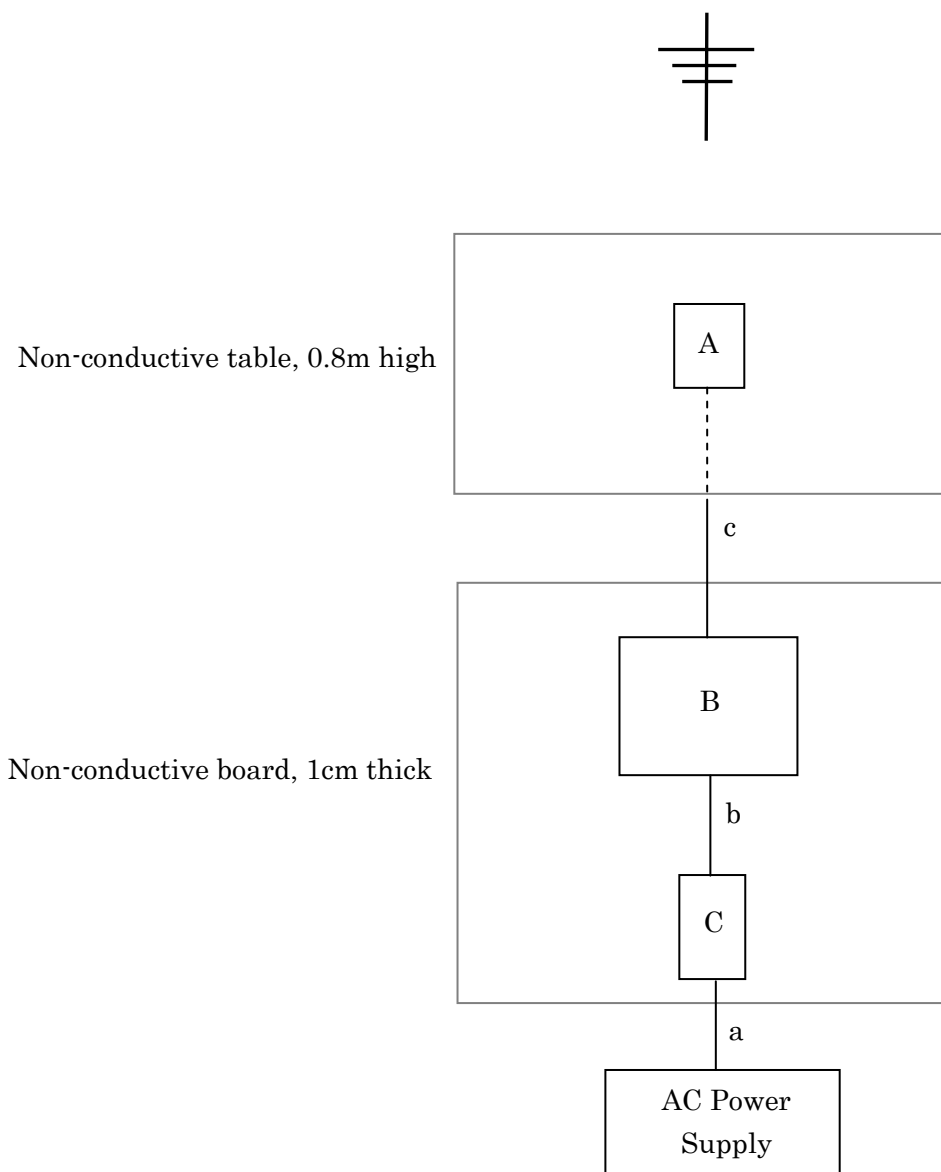

4.2 15. 207 AC Power Conducted Emission

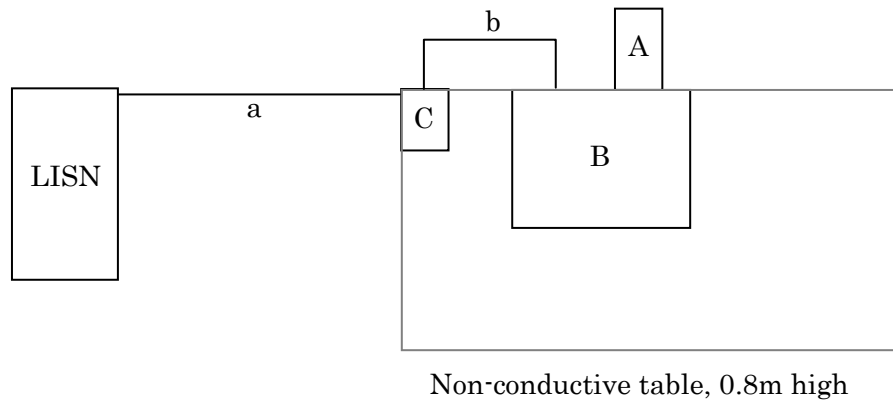

4.3 Test Mode

In test configurations above, EUT makes continuous RF transmitting with maximum power.

5. Measurement Result

5.1 15. 249(a) The Field Strength of Emissions

5.1.1 Setting Remarks

- The data lists in “5.1.4 Measured Data “ list the significant emission frequencies, measured levels, correction factor (includes cable and antenna corrections), the corrected reading, plus the limit.
- In the frequency range between 30MHz to 25 GHz (as 10th harmonics), the Electric Field Strength is measured in accordance with ANSI C63.4: 2003 and CISPR22: 1997.
- The test setup is made in accordance with ANSI C63.4: 2003.
- The antenna is measured at 1-4m height.
- The EUT is placed on the non-conductive table in the center of turntable. The height of this table is 0.8m.
- The distance between equipment and antenna is 3 m.
- The measurement is carried out with both horizontal and vertical antenna polarization.
- The highest radiation from the equipment is recorded.
- By varying the configuration of the test sample and the cable routing, it is attempted to maximize the emission.
- The test receiver with Quasi Peak and Average detector is in compliance with CISPR 16-1.
- The spectrum analyzer is set-up as following;

(Frequency range : 30 - 1000 MHz)

- ✓ Resolution bandwidth : 100 kHz
- ✓ Video bandwidth : 300 kHz
- ✓ Detector function : Peak
- ✓ Trace Mode : Max Hold

(Frequency range : Above 1000 MHz)

- ✓ Resolution bandwidth : 1 MHz
- ✓ Video bandwidth : 1 MHz
- ✓ Detector function : Peak
- ✓ Trace Mode : Max Hold

- EMI Test Receiver analyzer is set-up as following;
 - ✓ IF bandwidth : 120 kHz (Quasi-Peak Detector)
 - ✓ IF bandwidth : 1 MHz (Average Detector)
- See test configuration figure 4.1.

5.1.2 Minimum Standard

(a) Except as provided in paragraph (b) of this section, the field strength of emissions from intentional radiators operated within these frequency bands shall comply with the following:

Fundamental frequency	Field strength of fundamental (microvolts/meter)	Field strength of harmonics (microvolts/meter)
902-928 MHz	50	500
2400-2483.5 MHz	50	500
5725-5875 MHz	50	500
24.0-24.25 GHz	250	2500

5.1.3 Result

EUT complies with the requirement.

Uncertainty of measurement result: ± 3.28 dB

Temperature, Humidity : Refer to each data table

Note: All measurements was performed with supply voltage varied $\pm 15\%$, but all results were same. Therefore the data with rated voltage shall be recorded in this report.

5.1.4 Measured Data

30MHz to 1GHz, CH 08

Model Name : SM-DL79
 Serial No. : None
 Operator : O. Itogawa
 Power Supply : DC5V

Job No : CJ08-069537E
 Temp./Humi. : 24°C/39%
 Condition : USB Dongle CH08
 Remark :

Memo : RBW:30M~1GHz (120kHz)

LIMIT : FCC Part15 C 15.249 (3m) 30MHz-26.5GHz

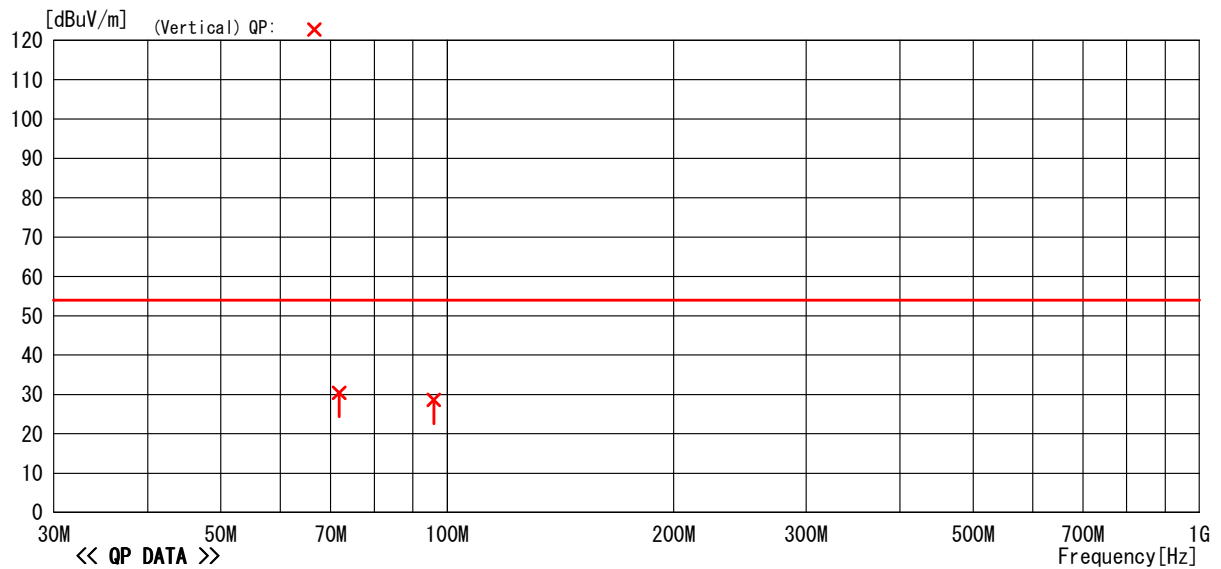
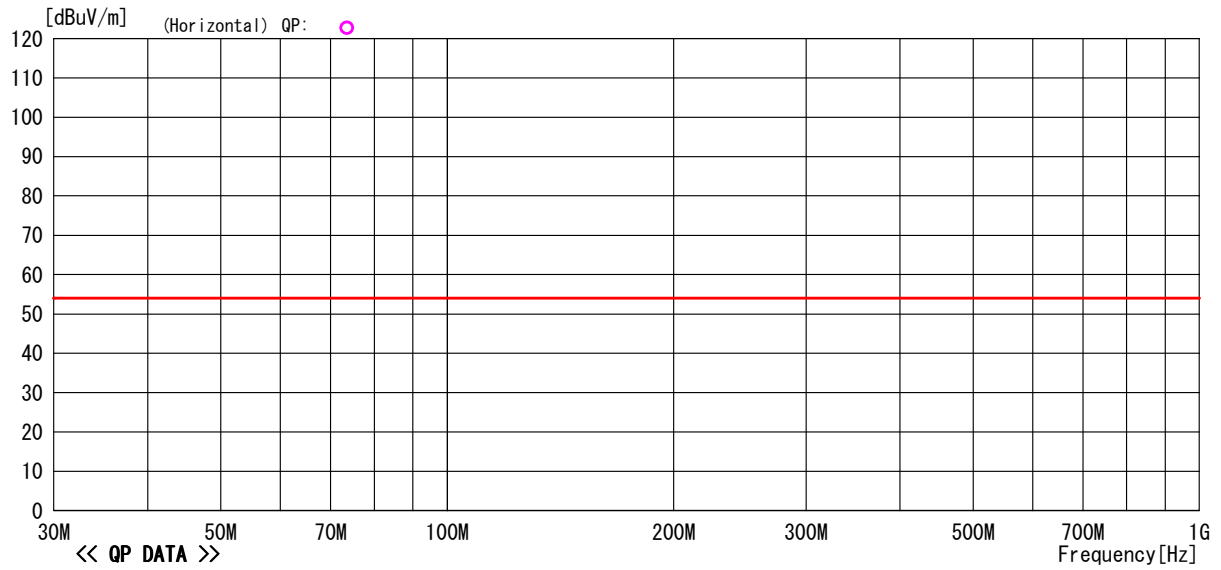

30MHz to 1GHz, CH 08

Model Name : SM-DL79
 Serial No. : None
 Operator : O. Itogawa
 Power Supply : DC5V

Job No : CJ08-069537E
 Temp./Humi. : 24°C/39%
 Condition : USB Dongle CH08
 Remark :

Memo : RBW:30M~1GHz (120kHz)

LIMIT : FCC Part15 C 15.249(3m)30MHz-26.5GHz

<< QP DATA >>

No	Freq.	Reading	C. Fac	Result	Limit	Margin	Pola.	Height	Angle	Ant	Comment
	[MHz]	[dBuV]	[dB/m]	[dBuV/m]	[dBuV/m]	[dB]	[H/V]	[cm]	[deg]	Type	
1	71.885	45.0	-14.6	30.4	54.0	23.6	Vert.	100	0	BC	
2	95.986	42.4	-13.8	28.6	54.0	25.4	Vert.	100	263	BC	

30MHz to 1GHz, CH 166

Model Name : SM-DL79
Serial No. : None
Operator : O. Itogawa
Power Supply : DC5V

Job No : CJ08-069537E
Temp./Humi. : 24°C/39%
Condition : USB Dongle CH166
Remark :

Memo : RBW:30M~1GHz (120kHz)

LIMIT : FCC Part15 C 15.249 (3m) 30MHz-26.5GHz

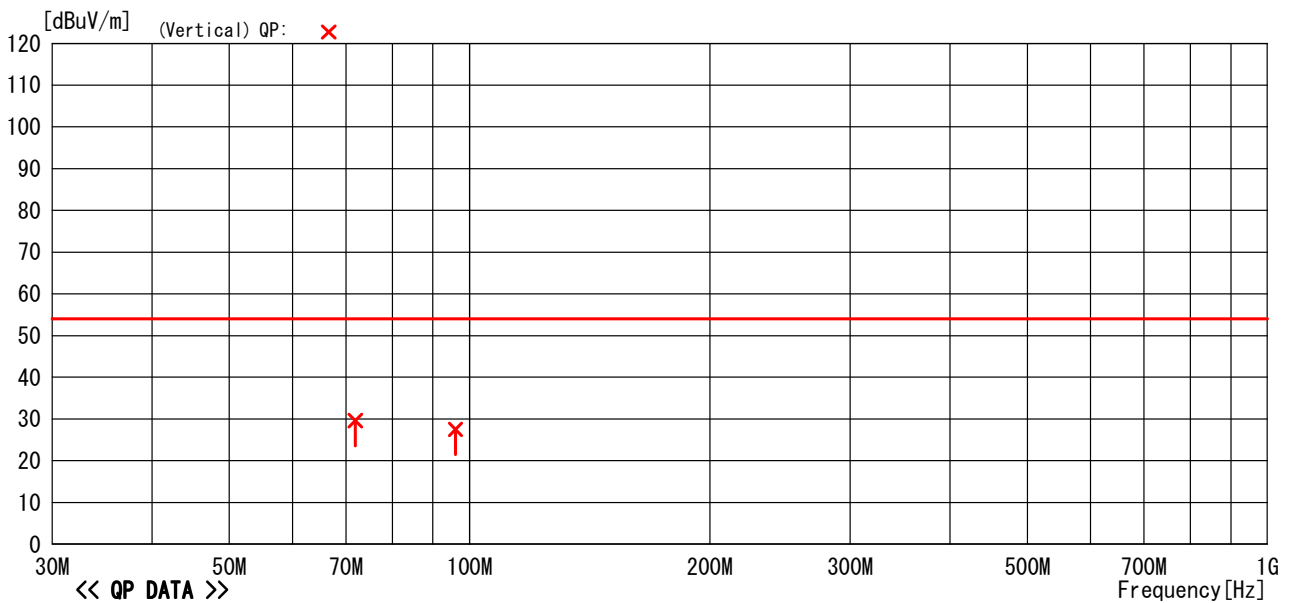
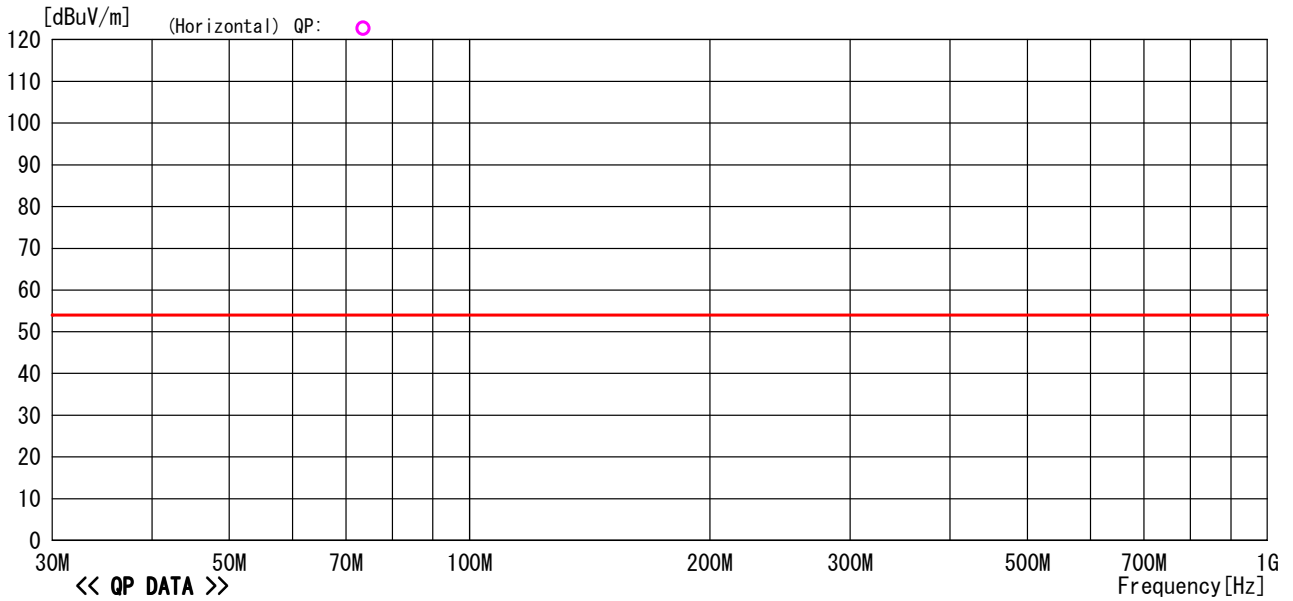

30MHz to 1GHz, CH 166

Model Name : SM-DL79
 Serial No. : None
 Operator : O. Itogawa
 Power Supply : DC5V

Job No : CJ08-069537E
 Temp./Humi. : 24°C/39%
 Condition : USB Dongle CH166
 Remark :

Memo : RBW:30M~1GHz(120kHz)

LIMIT : FCC Part15 C 15.249(3m) 30MHz-26.5GHz

<< QP DATA >>

No	Freq.	Reading	C. Fac	Result	Limit	Margin	Pola.	Height	Angle	Ant	Comment
	[MHz]	[dBuV]	[dB/m]	[dBuV/m]	[dBuV/m]	[dB]	[H/V]	[cm]	[deg]	Type	
1	71.915	44.2	-14.6	29.6	54.0	24.4	Vert.	100	0	BC	
2	96.026	41.3	-13.8	27.5	54.0	26.5	Vert.	100	0	BC	

30MHz to 1GHz, CH 321

Model Name : SM-DL79
Serial No. : None
Operator : O. Itogawa
Power Supply : DC5V

Job No : GJ08-069537E
Temp./Humi. : 24°C/39%
Condition : USB Dongle CH321
Remark :

Memo : RBW: 30M~1GHz (120kHz)

LIMIT : FCC Part15 C 15.249 (3m) 30MHz-26.5GHz

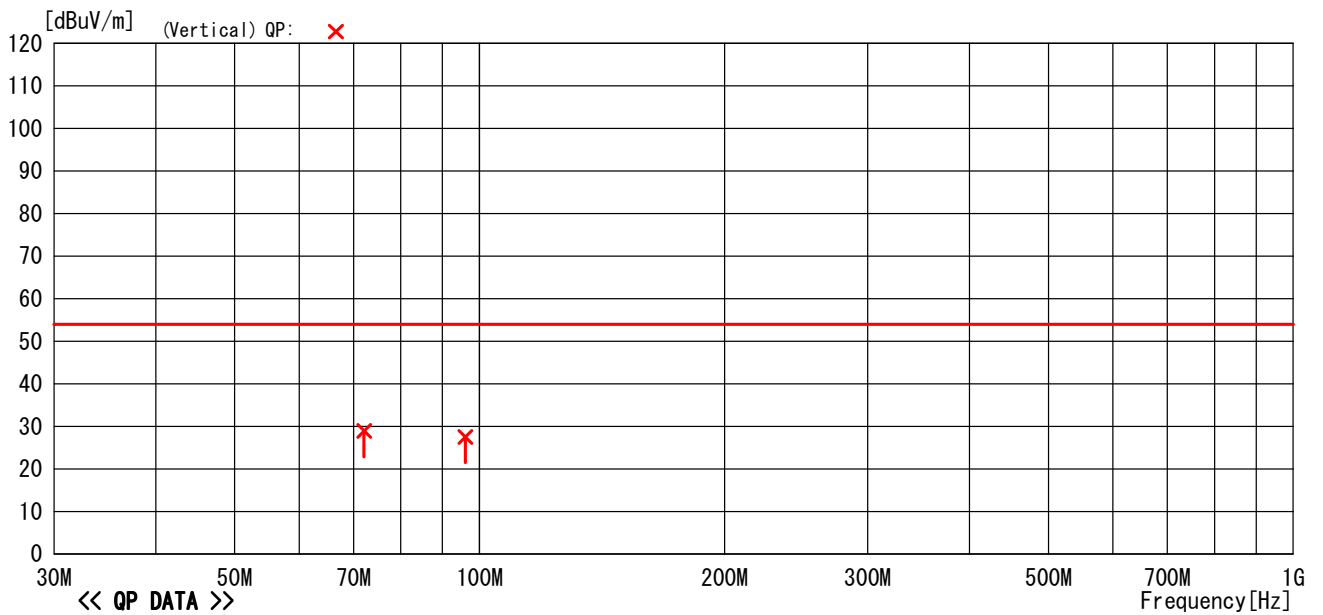
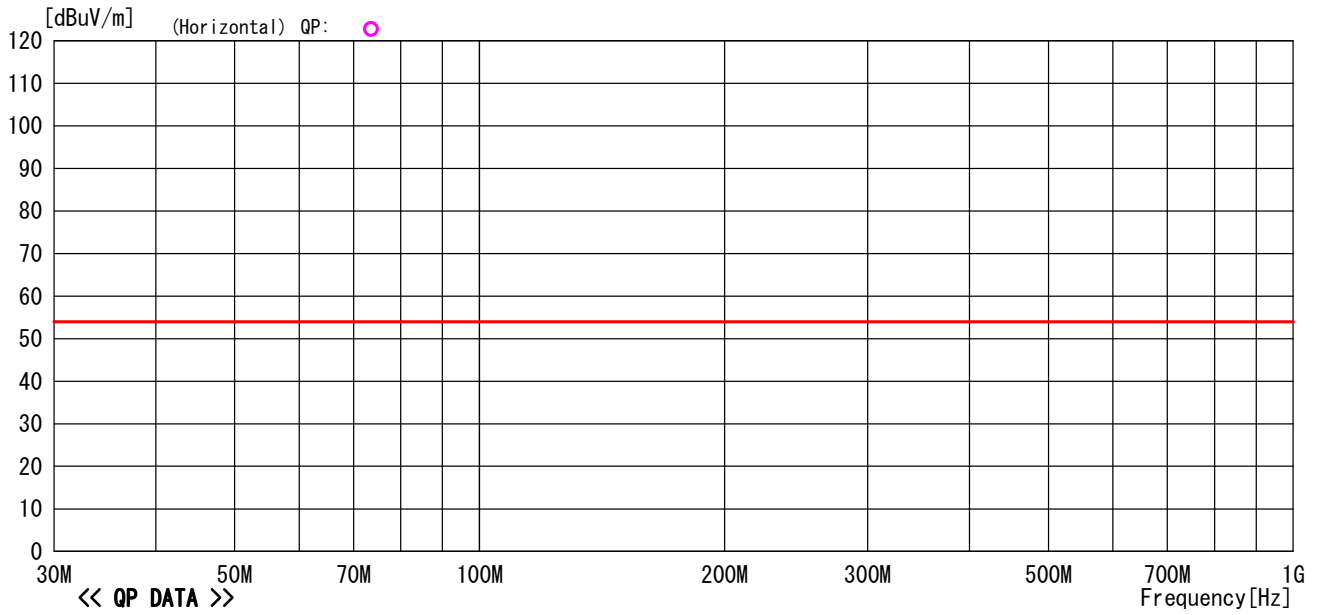

30MHz to 1GHz, CH 321

Model Name : SM-DL79
 Serial No. : None
 Operator : O. Itogawa
 Power Supply : DC5V

Job No : CJ08-069537E
 Temp./Humi. : 24°C/39%
 Condition : USB Dongle CH321
 Remark :

Memo : RBW:30M~1GHz (120kHz)

LIMIT : FCC Part15 C 15.249(3m)30MHz-26.5GHz

<< QP DATA >>

No	Freq.	Reading	C. Fac	Result	Limit	Margin	Pola.	Height	Angle	Ant	Comment
	[MHz]	[dBuV]	[dB/m]	[dBuV/m]	[dBuV/m]	[dB]	[H/V]	[cm]	[deg]	Type	
1	72.125	43.5	-14.6	28.9	54.0	25.1	Vert.	100	0	BC	
2	96.066	41.3	-13.8	27.5	54.0	26.5	Vert.	100	0	BC	

1GHz to 18GHz, CH 08

Model Name : SM-DL79
Serial No. : None
Operator : O. Itogawa
Power Supply : DC5V

Job No. : CJ08-069537E
Temp/Humi : 21°C/40%
Condition : USB Dongle CH08
Remark :

Memo : RBW:1GHz~(1MHz)

LIMIT : FCC Part15 C 15.249 (3m) 30MHz-26.5GHz

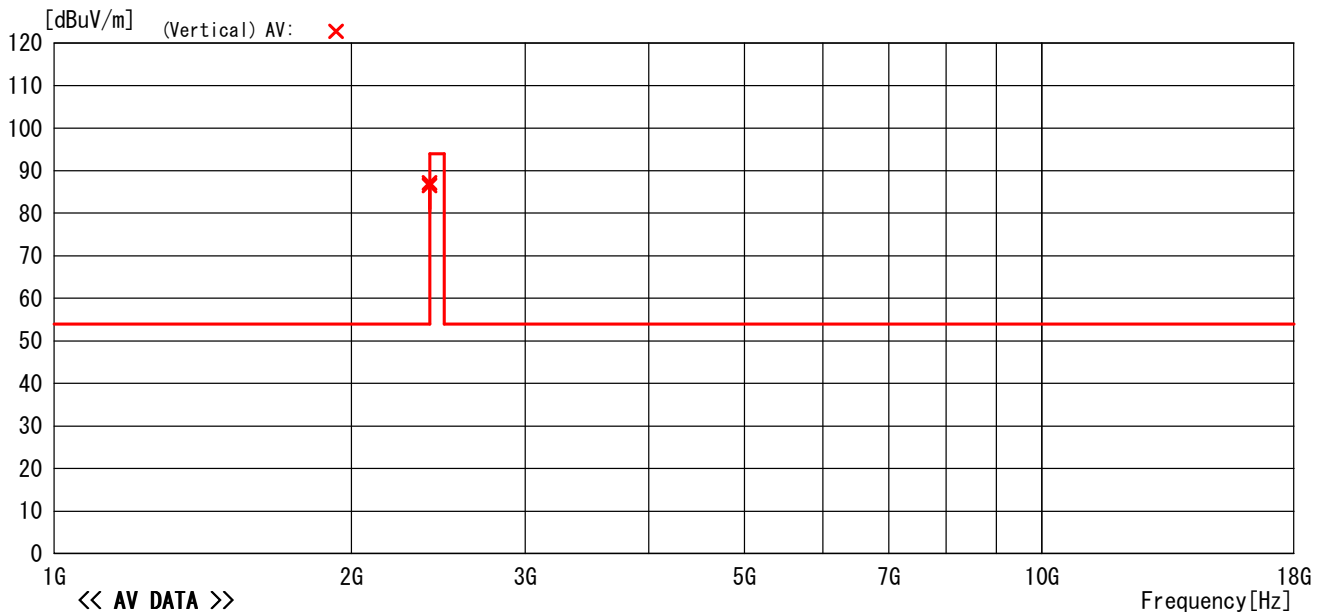
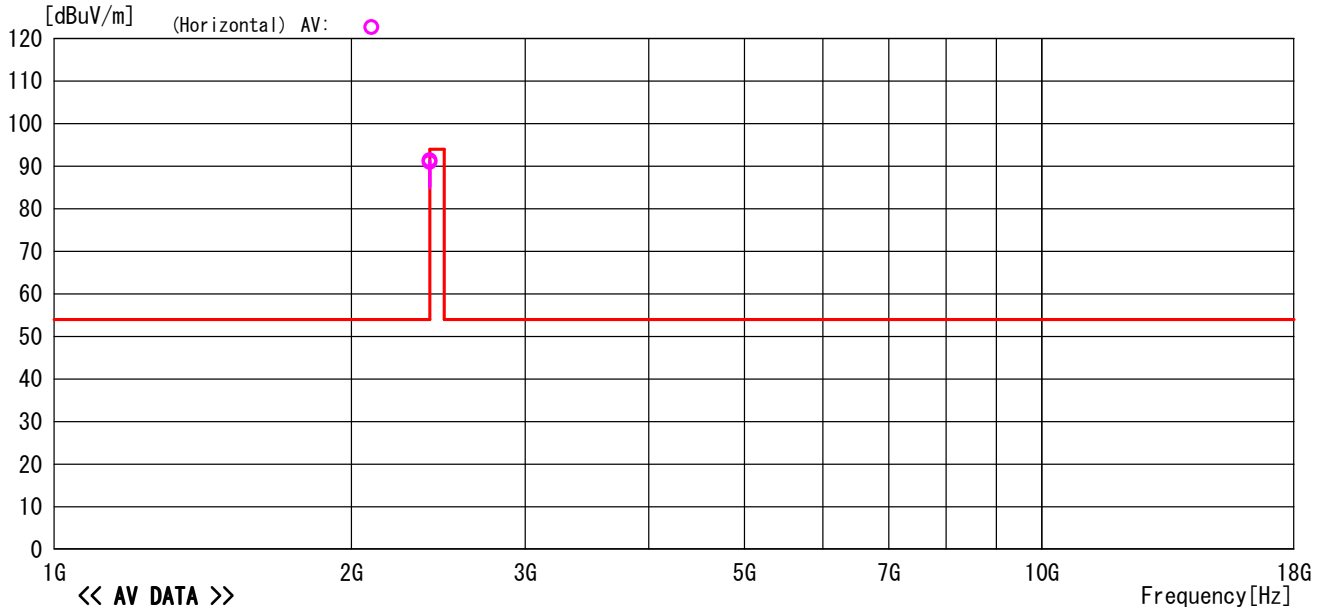

1GHz to 18GHz, CH 08

Model Name : SM-DL79
 Serial No. : None
 Operator : O. Itogawa
 Power Supply : DC5V

Job No. : CJ08-069537E
 Temp/Humi : 21°C/40%
 Condition : USB Dongle CH08
 Remark :

Memo : RBW:1GHz~(1MHz)

LIMIT : FCC Part15 C 15.249 (3m) 30MHz-26.5GHz

<<AV DATA>>

No	Freq.	Reading	Ant. Fac	Loss	Gain	Result	Limit	Margin	Pola.	Height	Angle	Ant	Comment
	[MHz]	[dBuV]	[dB/m]	[dB]	[dB]	[dBuV/m]	[dBuV/m]	[dB]	[H/V]	[cm]	[deg]	Type	
1	2402.144	92.7	28.1	-29.8	0.0	91.0	94.0	3.0	Hori.	100	226	HRN	AV Fundamental Frequency
2	2402.104	88.2	28.1	-29.8	0.0	86.5	94.0	7.5	Vert.	105	233	HRN	AV Fundamental Frequency

<<PEAK DATA>>

No	Freq.	Reading	Ant. Fac	Loss	Gain	Result	Limit	Margin	Pola.	Height	Angle	Ant	Comment
	[MHz]	[dBuV]	[dB/m]	[dB]	[dB]	[dBuV/m]	[dBuV/m]	[dB]	[H/V]	[cm]	[deg]	Type	
1	2402.144	93.1	28.1	-29.8	0.0	91.4	114.0	22.6	Hori.	100	226	HRN	PK Fundamental Frequency
2	2402.104	88.8	28.1	-29.8	0.0	87.1	114.0	26.9	Vert.	105	233	HRN	PK Fundamental Frequency

1GHz to 18GHz, CH166

Model Name : SM-DL79
Serial No. : None
Operator : O. Itogawa
Power Supply : DC5V

Job No. : CJ08-069537E
Temp/Humi : 21°C/40%
Condition : USB Dongle CH166
Remark :

Memo : RBW:1GHz~(1MHz)

LIMIT : FCC Part15 C 15.249(3m)30MHz-26.5GHz

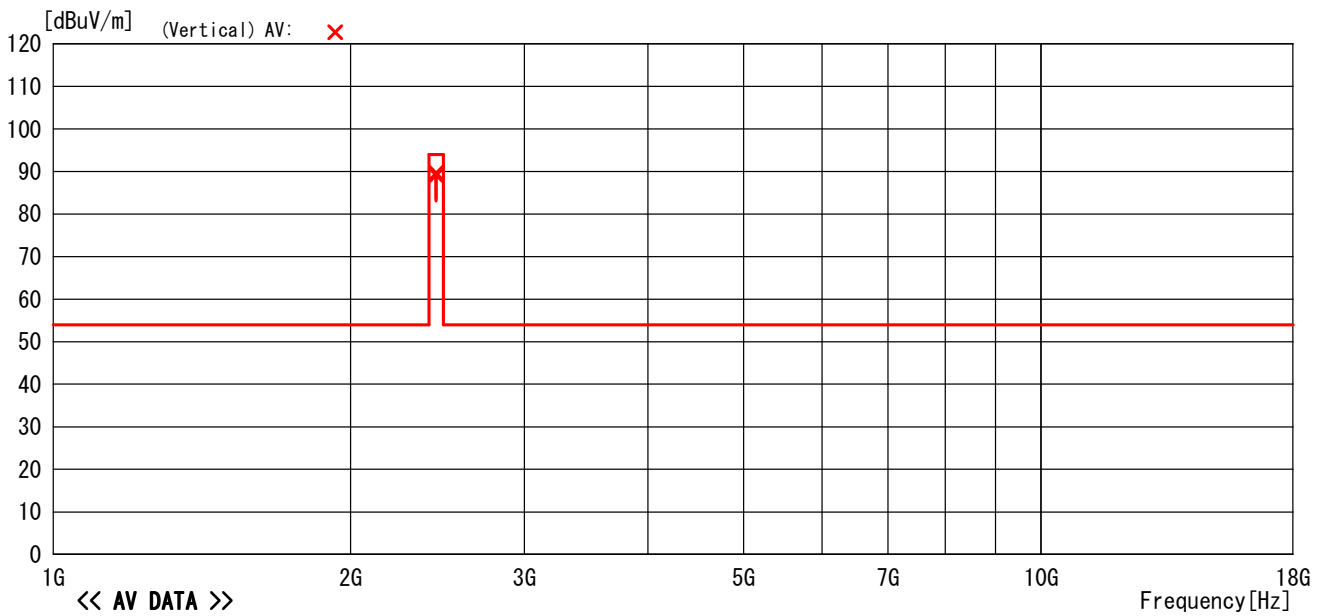
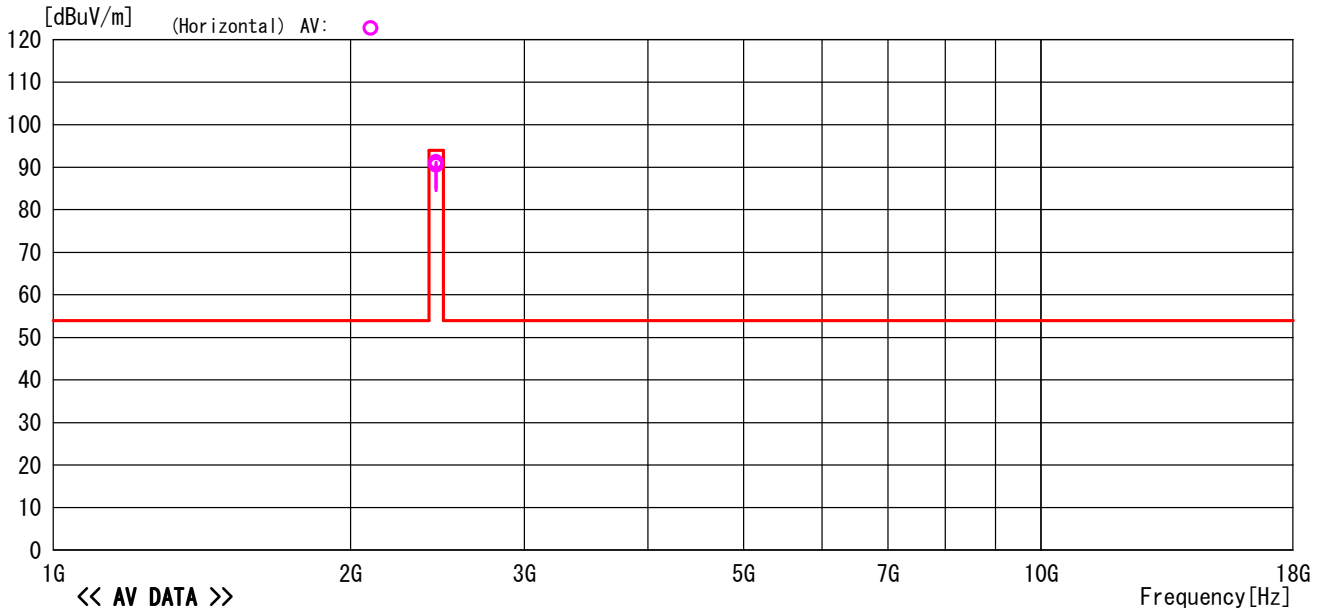

1GHz to 18GHz, CH166

Model Name : SM-DL79
 Serial No. : None
 Operator : O. Itogawa
 Power Supply : DC5V

Job No. : CJ08-069537E
 Temp/Humi : 21°C/40%
 Condition : USB Dongle CH166
 Remark :

Memo : RBW:1GHz~(1MHz)

LIMIT : FCC Part15 C 15.249(3m)30MHz-26.5GHz

<<AV DATA>>

No	Freq.	Reading	Ant. Fac	Loss	Gain	Result	Limit	Margin	Pola.	Height	Angle	Ant	Comment
	[MHz]	[dBuV]	[dB/m]	[dB]	[dB]	[dBuV/m]	[dBuV/m]	[dB]	[H/V]	[cm]	[deg]	Type	
1	2441.517	92.2	28.2	-29.8	0.0	90.6	94.0	3.4	Hori.	100	233	HRN	AV Fundamental Frequency
2	2441.457	90.7	28.2	-29.8	0.0	89.1	94.0	4.9	Vert.	100	82	HRN	AV Fundamental Frequency

<<PEAK DATA>>

No	Freq.	Reading	Ant. Fac	Loss	Gain	Result	Limit	Margin	Pola.	Height	Angle	Ant	Comment
	[MHz]	[dBuV]	[dB/m]	[dB]	[dB]	[dBuV/m]	[dBuV/m]	[dB]	[H/V]	[cm]	[deg]	Type	
1	2441.517	92.8	28.2	-29.8	0.0	91.2	114.0	22.8	Hori.	100	233	HRN	PK Fundamental Frequency
2	2441.457	91.2	28.2	-29.8	0.0	89.6	114.0	24.4	Vert.	100	82	HRN	PK Fundamental Frequency

1GHz to 18GHz, CH321

Model Name : SM-DL79
Serial No. : None
Operator : O. Itogawa
Power Supply : DC5V

Job No. : CJ08-069537E
Temp/Humi : 21°C/40%
Condition : USB Dongle CH321
Remark :

Memo : RBW:1GHz~(1MHz)

LIMIT : FCC Part15 C 15.249(3m)30MHz-26.5GHz

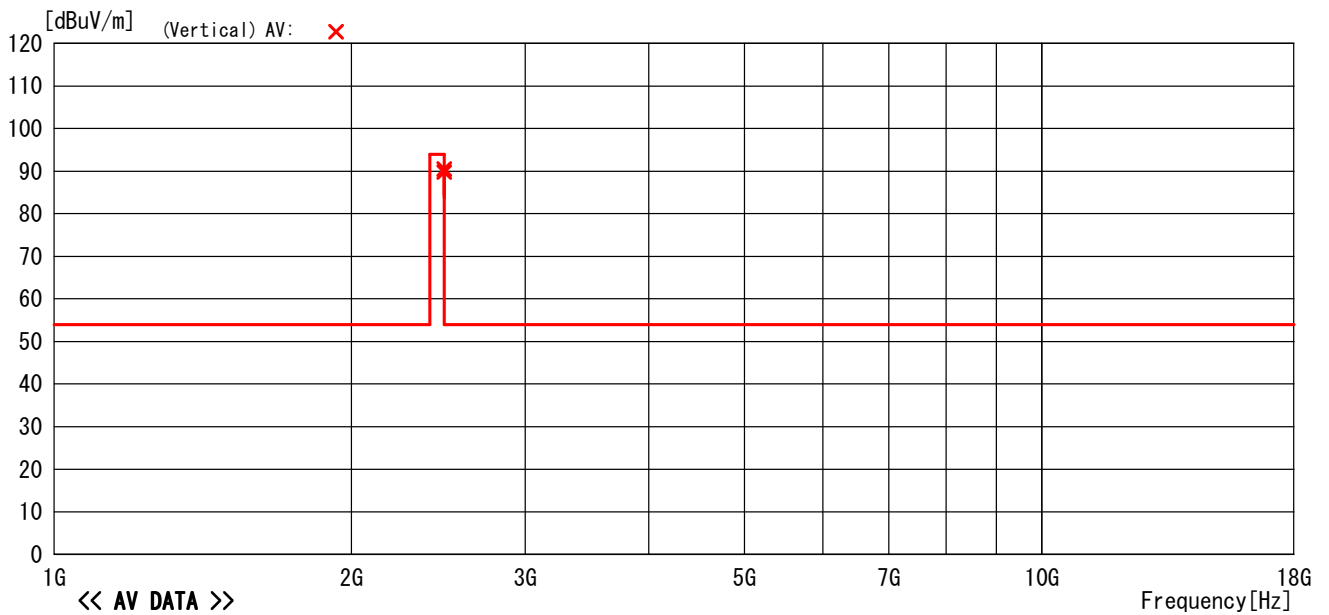
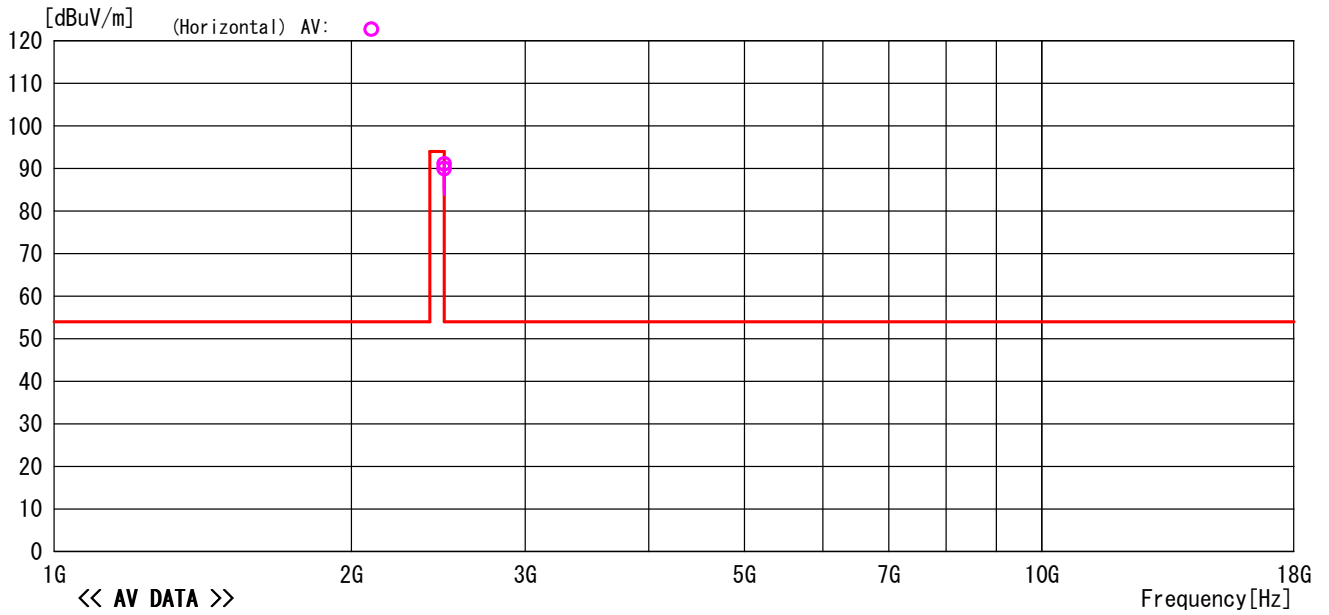

1GHz to 18GHz, CH 321

Model Name : SM-DL79
 Serial No. : None
 Operator : O. Itogawa
 Power Supply : DC5V

Job No. : CJ08-069537E
 Temp/Humi : 21°C/40%
 Condition : USB Dongle CH321
 Remark :

Memo : RBW:1GHz~(1MHz)

LIMIT : FCC Part15 C 15.249(3m)30MHz-26.5GHz

<<AV DATA>>

No	Freq.	Reading	Ant. Fac	Loss	Gain	Result	Limit	Margin	Pola.	Height	Angle	Ant	Comment
	[MHz]	[dBuV]	[dB/m]	[dB]	[dB]	[dBuV/m]	[dBuV/m]	[dB]	[H/V]	[cm]	[deg]	Type	
1	2480.314	91.6	28.2	-29.8	0.0	90.0	94.0	4.0	Hori.	100	234	HRN	AV Fundamental Frequency
2	2480.214	91.4	28.2	-29.8	0.0	89.8	94.0	4.2	Vert.	100	79	HRN	AV Fundamental Frequency

<<PEAK DATA>>

No	Freq.	Reading	Ant. Fac	Loss	Gain	Result	Limit	Margin	Pola.	Height	Angle	Ant	Comment
	[MHz]	[dBuV]	[dB/m]	[dB]	[dB]	[dBuV/m]	[dBuV/m]	[dB]	[H/V]	[cm]	[deg]	Type	
1	2480.314	92.7	28.2	-29.8	0.0	91.1	114.0	22.9	Hori.	100	234	HRN	PK Fundamental Frequency
2	2480.214	92.1	28.2	-29.8	0.0	90.5	114.0	23.5	Vert.	100	79	HRN	PK Fundamental Frequency

18GHz to 26.5GHz, CH 08

Model Name	: SM-DL79	Job No	: CJ08-069537E
Serial No.	: None	Temp/Humi	: 24°C/39%
Operator	: O. Itogawa	Condition	: USB Dongle CH08
Power Supply	: DC5V	Remark	:
Memo	: RBW:1MHz (1G~)		

LIMIT : FCC Part15 C 15.249(3m)30MHz-26.5GHz

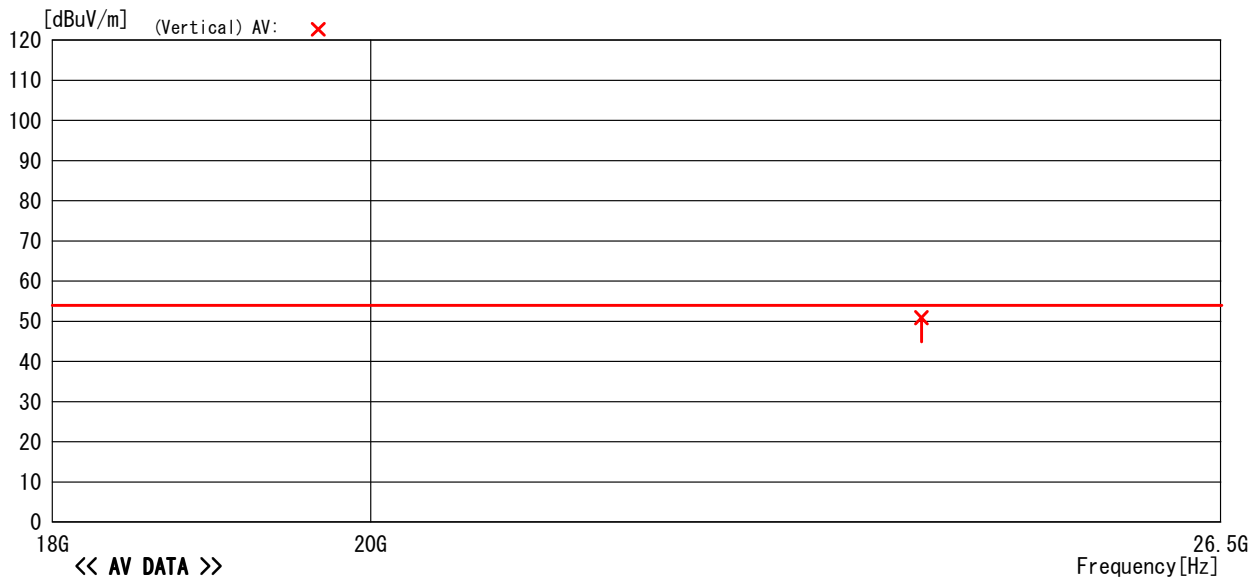
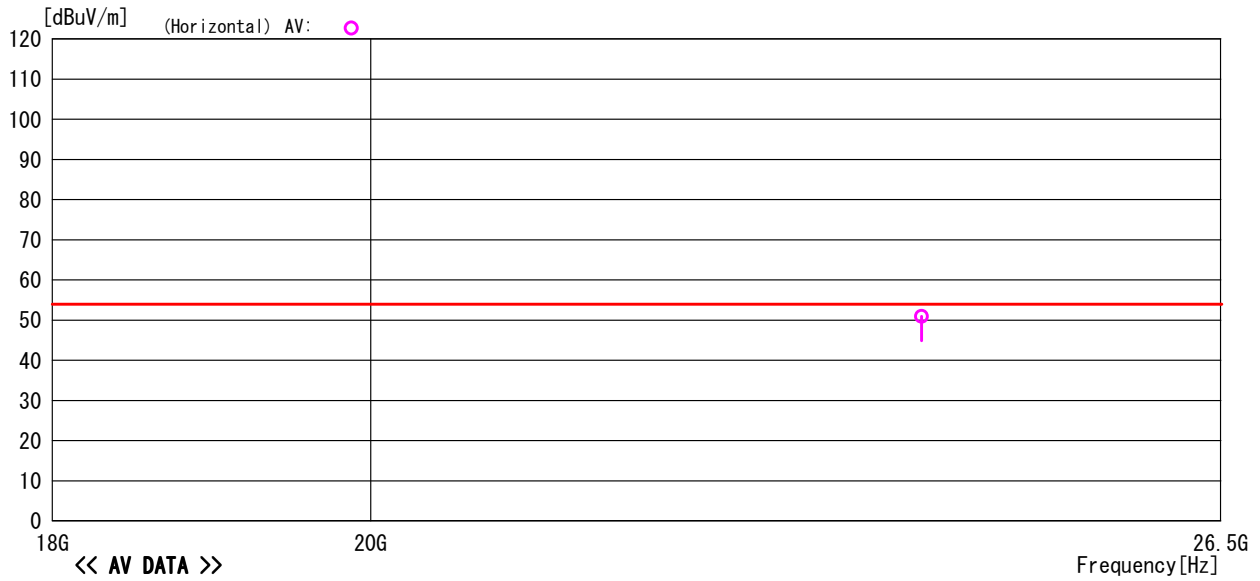

-TEPTO-DV/Ver 1.80.0020

Note: Except for measured point, AV was within a limit.

18GHz to 26.5GHz, CH 08

Model Name : SM-DL79
 Serial No. : None
 Operator : O. Itogawa
 Power Supply : DC5V

Job No : CJ08-069537E
 Temp/Humi : 24°C/39%
 Condition : USB Dongle CH08
 Remark :

Memo : RBW:1MHz(1G~)

LIMIT : FCC Part15 C 15.249(3m)30MHz-26.5GHz

<<AV DATA>>

No	Freq.	Reading	C.Fac	Result	Limit	Margin	Pola.	Height	Angle	Ant	Comment
	[MHz]	[dBuV]	[dB/m]	[dBuV/m]	[dBuV/m]	[dB]	[H/V]	[cm]	[deg]	Type	
1	24000.000	30.2	20.7	50.9	54.0	3.1	Hori.	100	0	HRN	AV Freq:24000.000MHz
2	24000.000	30.2	20.7	50.9	54.0	3.1	Vert.	100	0	HRN	AV Freq:24000.000MHz

<<PEAK DATA>>

No	Freq.	Reading	C.Fac	Result	Limit	Margin	Pola.	Height	Angle	Ant	Comment
	[MHz]	[dBuV]	[dB/m]	[dBuV/m]	[dBuV/m]	[dB]	[H/V]	[cm]	[deg]	Type	
1	24000.000	30.3	20.7	51.0	74.0	23.0	Hori.	100	0	HRN	PK Freq:24000.000MHz
2	24000.000	30.3	20.7	51.0	74.0	23.0	Vert.	100	0	HRN	PK Freq:24000.000MHz

18GHz to 26.5GHz, CH166

Model Name : SM-DL79
Serial No. : None
Operator : O. Itogawa
Power Supply : DC5V

Job No : CJ08-069537E
Temp/Humi : 24°C/39%
Condition : USB Dongle CH166
Remark :

Memo : RBW:1MHz(1G~)

LIMIT : FCC Part15 C 15.249(3m)30MHz-26.5GHz

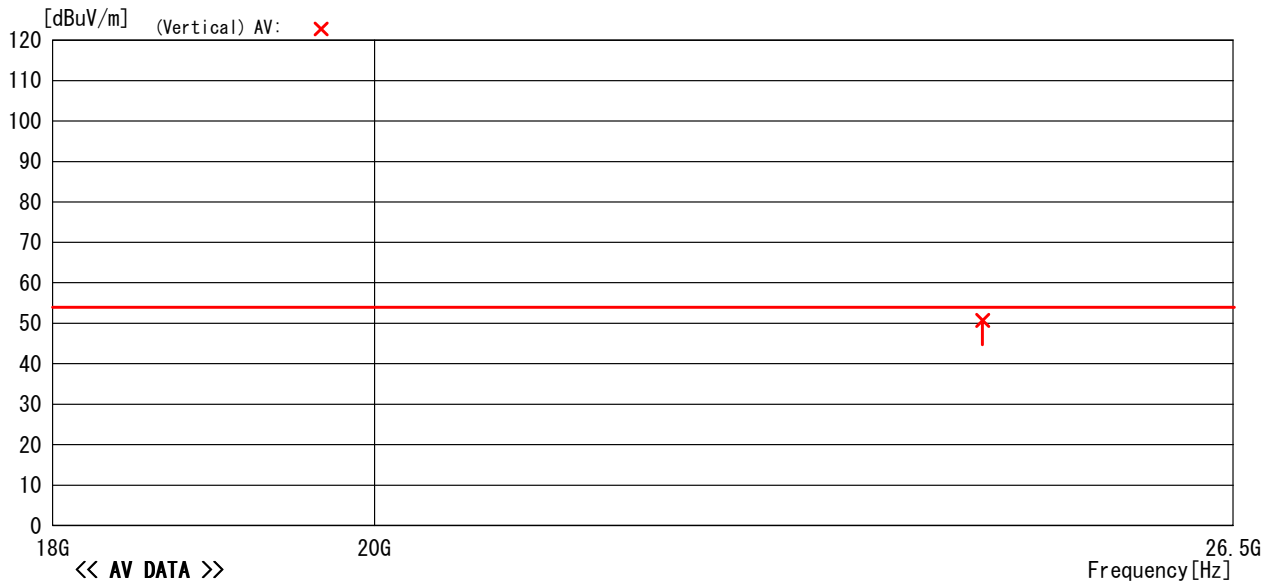
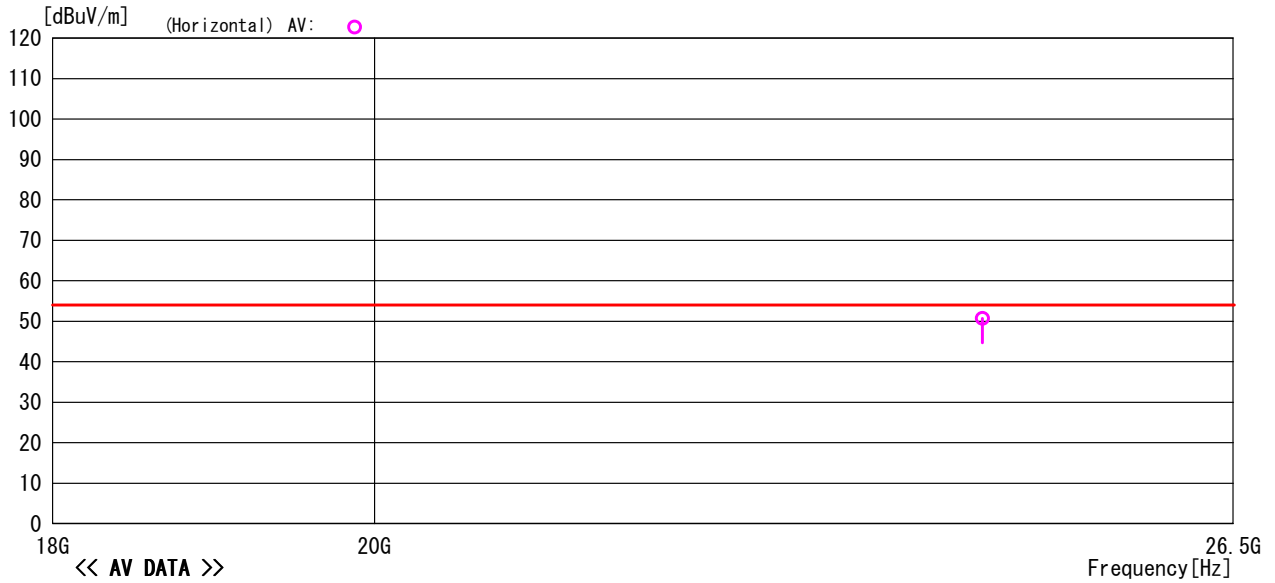

-TEPT0-DV/Ver 1.80.0020

Note: Except for measured point, AV was within a limit.

18GHz to 26.5GHz, CH166

Model Name : SM-DL79
 Serial No. : None
 Operator : O. Itogawa
 Power Supply : DC5V

Job No : CJ08-069537E
 Temp/Humi : 24°C/39%
 Condition : USB Dongle CH166
 Remark :

Memo : RBW:1MHz(1G~)

LIMIT : FCC Part15 C 15.249(3m)30MHz-26.5GHz

<<AV DATA>>

No	Freq.	Reading	C.Fac	Result	Limit	Margin	Pola.	Height	Angle	Ant	Comment
	[MHz]	[dBuV]	[dB/m]	[dBuV/m]	[dBuV/m]	[dB]	[H/V]	[cm]	[deg]	Type	
1	24410.000	30.1	20.6	50.7	54.0	3.3	Hori.	100	0	HRN	AV Freq:24410.000MHz
2	24410.000	30.1	20.6	50.7	54.0	3.3	Vert.	100	0	HRN	AV Freq:24410.000MHz

<<PEAK DATA>>

No	Freq.	Reading	C.Fac	Result	Limit	Margin	Pola.	Height	Angle	Ant	Comment
	[MHz]	[dBuV]	[dB/m]	[dBuV/m]	[dBuV/m]	[dB]	[H/V]	[cm]	[deg]	Type	
1	24410.000	30.2	20.6	50.8	74.0	23.2	Hori.	100	0	HRN	PK Freq:24410.000MHz
2	24410.000	30.2	20.6	50.8	74.0	23.2	Vert.	100	0	HRN	PK Freq:24410.000MHz

18GHz to 26.5GHz, CH 321

Model Name : SM-DL79
 Serial No. : None
 Operator : O. Itogawa
 Power Supply : DC5V

Job No : CJ08-069537E
 Temp/Humi : 24°C/39%
 Condition : USB Dongle CH321
 Remark :

Memo : RBW:1MHz (1G~)

LIMIT : FCC Part15 C 15.249(3m)30MHz-26.5GHz

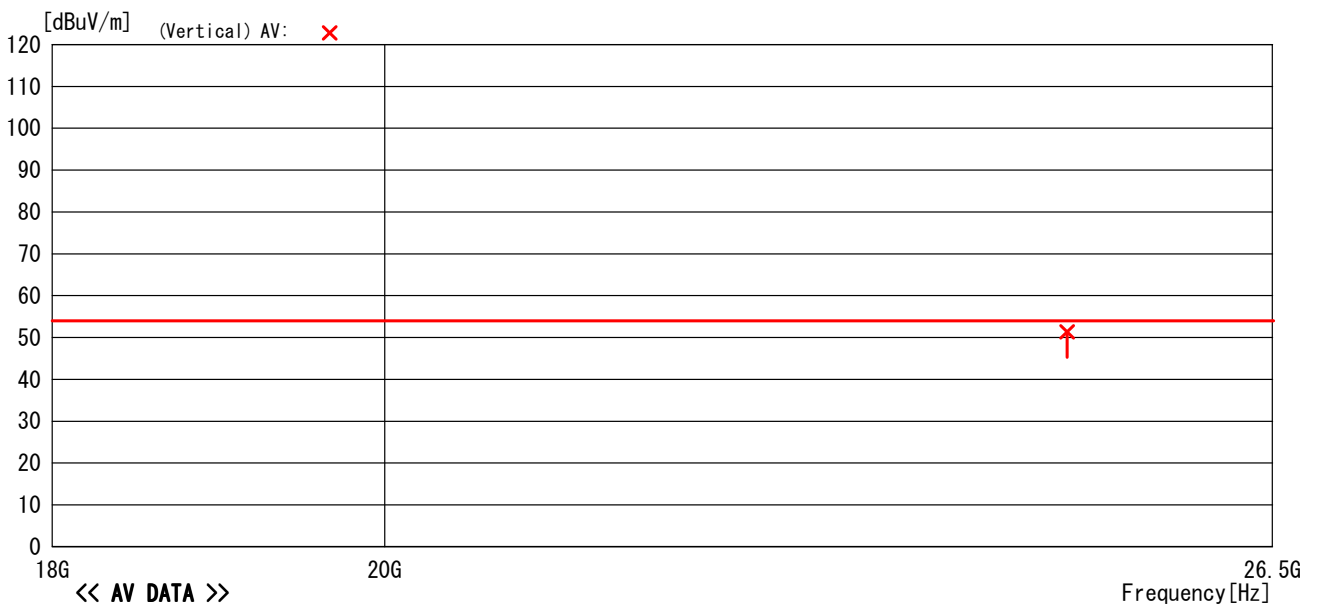
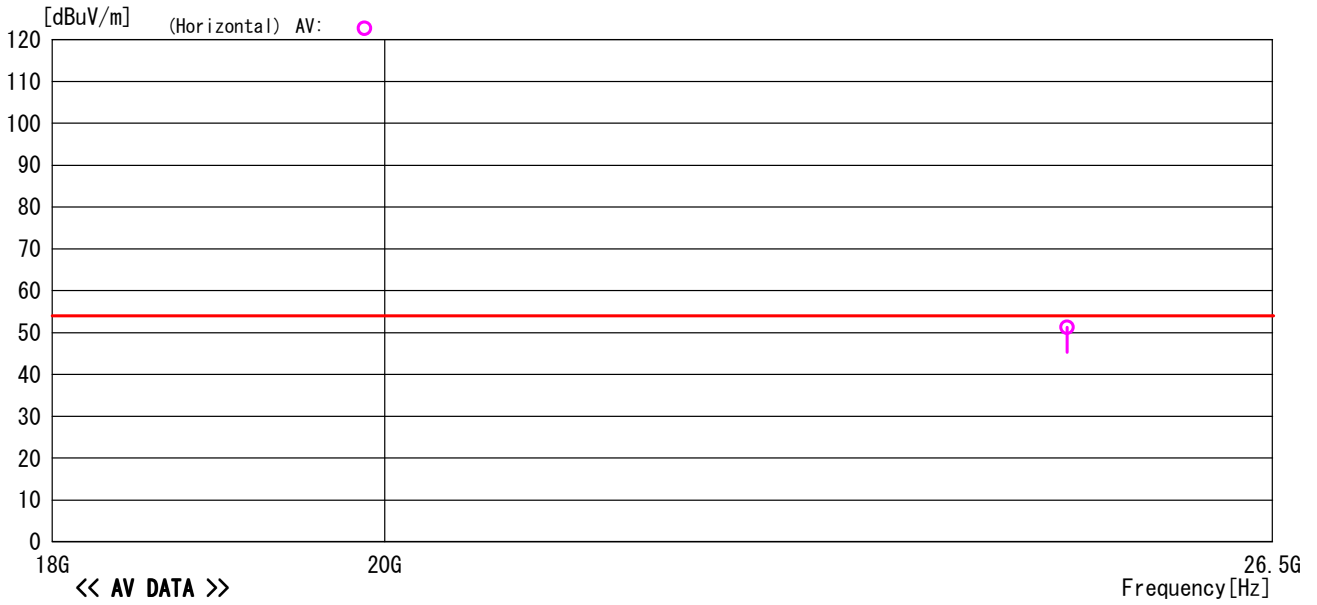

-TEPT0-DV/Ver 1.80.0020

Note: Except for measured point, AV was within a limit.

18GHz to 26.5GHz, CH 321

Model Name : SM-DL79
 Serial No. : None
 Operator : O. Itogawa
 Power Supply : DC5V

Job No : CJ08-069537E
 Temp/Humi : 24°C/39%
 Condition : USB Dongle CH321
 Remark :

Memo : RBW:1MHz (1G~)

LIMIT : FCC Part15 C 15.249(3m)30MHz-26.5GHz

<<AV DATA>>

No	Freq.	Reading	C.Fac	Result	Limit	Margin	Pola.	Height	Angle	Ant	Comment
	[MHz]	[dBuV]	[dB/m]	[dBuV/m]	[dBuV/m]	[dB]	[H/V]	[cm]	[deg]	Type	
1	24830.000	30.5	20.8	51.3	54.0	2.7	Hori.	100	0	HRN	AV Freq:24830.000MHz
2	24830.000	30.5	20.8	51.3	54.0	2.7	Vert.	100	0	HRN	AV Freq:24830.000MHz

<<PEAK DATA>>

No	Freq.	Reading	C.Fac	Result	Limit	Margin	Pola.	Height	Angle	Ant	Comment
	[MHz]	[dBuV]	[dB/m]	[dBuV/m]	[dBuV/m]	[dB]	[H/V]	[cm]	[deg]	Type	
1	24830.000	30.6	20.8	51.4	74.0	22.6	Hori.	100	0	HRN	PK Freq:24830.000MHz
2	24830.000	30.6	20.8	51.4	74.0	22.6	Vert.	100	0	HRN	PK Freq:24830.000MHz

5.2 15. 207 AC Power Conducted Emission

5.2.1 Setting Remarks

- Configure the EUT System in accordance with ANSI C63.4-2003.
- Non-conductive board (10mm thick) for EUT and non-conductive table (80cm high) for personal computer were used.
- Other power cord of support equipment is connected to another LISN to isolate its emission from the measured emission of EUT.
- The measuring port of LISN for support equipment was terminated by the 50Ω
- Activate the EUT System and run the software prepared for the test, if necessary.
- Refer to test configuration figure 4.2.

5.2.2 Minimum Standard

15. 207 (a) Except as shown in paragraphs (b) and (c) of this section, for an intentional radiator that is designed to be connected to the public utility (AC) power line, the radio frequency voltage that is conducted back onto the AC power line on any frequency or frequencies within the band 150 kHz to 30 MHz shall not exceed the limits in the following table, as measured using a 50 μH/50 ohms line impedance stabilization network (LISN). Compliance with the provisions of this paragraph shall be based on the measurement of the radio frequency voltage between each power line and ground at the power terminal. The lower limit applies at the boundary between the frequency ranges.

Frequency of Emission (MHz)	Conducted Limit (dBuV)	
	Quasi-peak	Average
0.15-0.5	66 to 56 *	56 to 46 *
0.5-5	56	46
5-30	60	50

* Decreases with the logarithm of the frequency.

5.2.3 Result

EUT complies with the requirement.

Uncertainty of measurement : ± 2.26 dB
 Temperature, Humidity : 24°C, 43 %

5.2.4 Measured Data

Measured Value Table

Model Name : SM-DL79
 Serial No. : None
 Operator : O. Itogawa
 Power Supply : AC120V, 60Hz

Job No : CJ08-069537E
 Temp/Humi : 24°C/43%
 Condition : Operated
 Remark : USBトングル

Memo :

LIMIT : FCC 15.207(QP)
 FCC 15.207(AV)

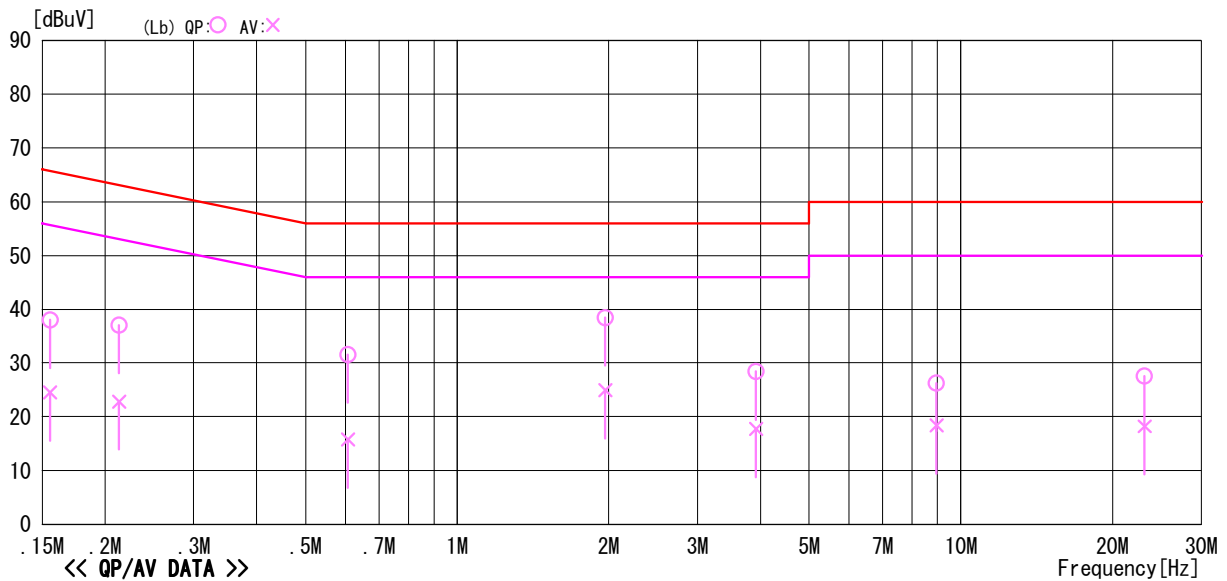
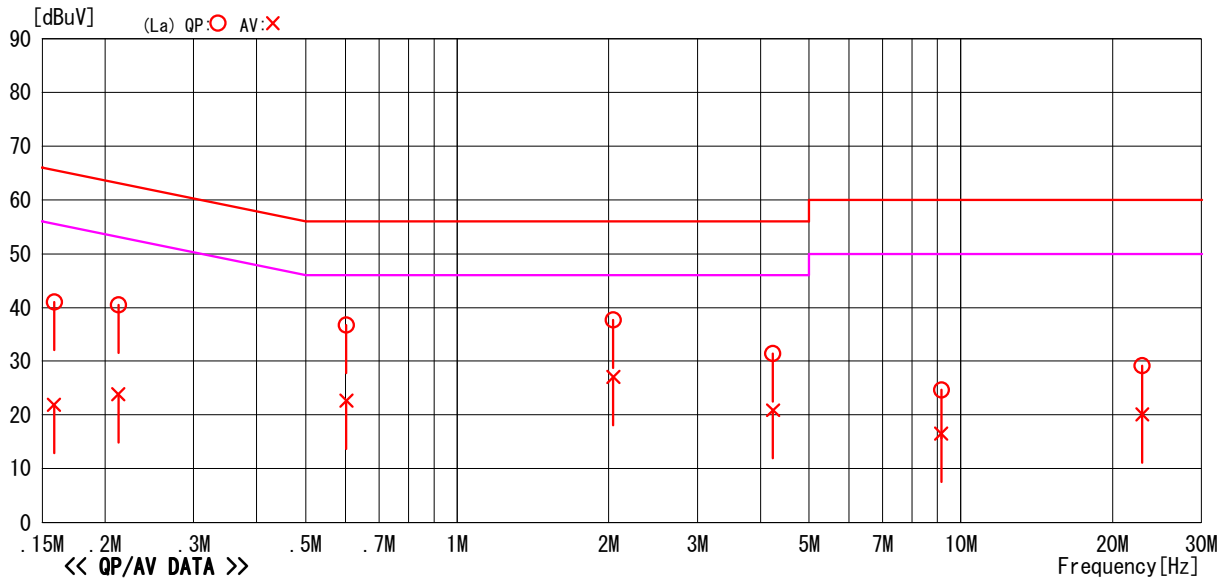

5.2.4 Measured Data (Continued)

Measured Value Table

Model Name : SM-DL79
 Serial No. : None
 Operator : O. Itogawa
 Power Supply : AC120V, 60Hz

Job No : CJ08-069537E
 Temp/Humi : 24°C/43%
 Condition : Operated
 Remark : USBトングル

Memo :

LIMIT : FCC 15.207 (QP)
 FCC 15.207 (AV)

<< QP/AV DATA >>

No	Freq. [MHz]	Reading Level		C. Fac [dB]	Results		Limit		Margin		Phase	Comment
		QP	AV		QP	AV	QP	AV	QP	AV		
		[dBuV]	[dBuV]		[dBuV]	[dBuV]	[dBuV]	[dBuV]	[dB]	[dB]		
1	0.15840	30.8	11.7	10.2	41.0	21.9	65.5	55.5	24.5	33.6	La	
2	0.21241	30.4	13.8	10.1	40.5	23.9	63.1	53.1	22.6	29.2	La	
3	0.60307	26.6	12.5	10.1	36.7	22.6	56.0	46.0	19.3	23.4	La	
4	2.04203	27.6	17.0	10.1	37.7	27.1	56.0	46.0	18.3	18.9	La	
5	4.23659	21.2	10.6	10.3	31.5	20.9	56.0	46.0	24.5	25.1	La	
6	9.15594	14.0	6.0	10.6	24.6	16.6	60.0	50.0	35.4	33.5	La	
7	22.93427	18.1	9.0	11.1	29.2	20.1	60.0	50.0	30.8	29.9	La	
8	0.15543	27.8	14.3	10.2	38.0	24.5	65.7	55.7	27.7	31.2	Lb	
9	0.21333	26.9	12.7	10.1	37.0	22.8	63.1	53.1	26.1	30.3	Lb	
10	0.60745	21.5	5.6	10.1	31.6	15.7	56.0	46.0	24.4	30.3	Lb	
11	1.96810	28.4	14.8	10.1	38.5	24.9	56.0	46.0	17.5	21.1	Lb	
12	3.92513	18.2	7.5	10.2	28.4	17.7	56.0	46.0	27.6	28.3	Lb	
13	8.94609	15.8	7.8	10.5	26.3	18.3	60.0	50.0	33.7	31.7	Lb	
14	23.16440	16.6	7.2	11.0	27.6	18.2	60.0	50.0	32.4	31.8	Lb	

5.3 15. 247(d) Band Edge Measurement

5.3.1 Setting Remarks

- EUT directly connects to the spectrum analyzer via calibrated coaxial cable and 10 dB attenuator.
- The loss of the coaxial cable is maximum 1 dB.
- The emission at the band edge is measured by using the marker function of spectrum analyzer.
- The peak of the in-band emission is measured by using the marker to peak function of spectrum analyzer.
- This measurement is repeated in both side of the spectrum.
- The spectrum analyzer is set-up as following;
 - ✓ Frequency Span : 30MHz
 - ✓ Resolution bandwidth : 300kHz (1% of frequency span)
 - ✓ Video bandwidth : > RBW
 - ✓ Sweep : Auto
 - ✓ Detector function : Peak
 - ✓ Trace Mode : Max Hold
- Where bandedge spectrum is too rough to find precise edge point, larger RBW i.e. 1MHz, 3MHz shall be applied as severer condition.
- See test configuration figure 4.2.

5.3.2 Minimum Standard

In any 100kHz bandwidth outside the frequency band in which the transmitter is operating, emissions shall be at least 20 dB below the fundamental emission or shall not exceed the following field strength limits. Emissions falling in the restricted bands of 15.205 shall not exceed the following field strength limits:

Frequency of Emission (MHz)	Limit of the band edge spurious emission (dB μ V)	
	Peak	Average
Below 2,400.0		
Above 2,483.5	74	54

5.3.3 Result

EUT complies with the requirement.

Uncertainty of measurement result: ± 2.6 dB

Temperature, Humidity : 24°C, 40%

5.3.4 Measured Data

The band edge emissions are calculated as following;

(Horizontal)

CH	P _{max}	P _{av}	P _{dev}	c.f.	E _{be}	E _{av}	Limit(E _{be})	Limit(E _{av})	Margin(E _{be})	Margin(E _{av})
8 CH (2402.50 MHz)	90.22	89.15	42.40	-1.7	46.1	45.1	74.0	54.0	27.9	9.0
321 CH (2480.75 MHz)	91.32	90.67	42.15	-1.7	47.5	46.8	74.0	54.0	26.5	7.2

(Vertical)

CH	P _{max}	P _{av}	P _{dev}	c.f.	E _{be}	E _{av}	Limit(E _{be})	Limit(E _{av})	Margin(E _{be})	Margin(E _{av})
8 CH (2402.50 MHz)	92.61	91.68	42.60	-1.7	48.3	47.4	74.0	54.0	25.7	6.6
321 CH (2480.75 MHz)	92.74	92.09	43.37	-1.7	47.7	47.0	74.0	54.0	26.3	7.0

NOTE Vertical and Horizontal were measured and Vertical was confirmed as the worst.

- P_{max} : Maximum peak power of the fundamental.
- P_{av} : Average of the fundamental.
- P_{dev} : The amplitude delta between the peak power and the band edge emission.
- E_{be} : Band edge emission.
- E_{av} : Average of the band edge emission.

5.4 15. 215 (c) 20 dB Bandwidth

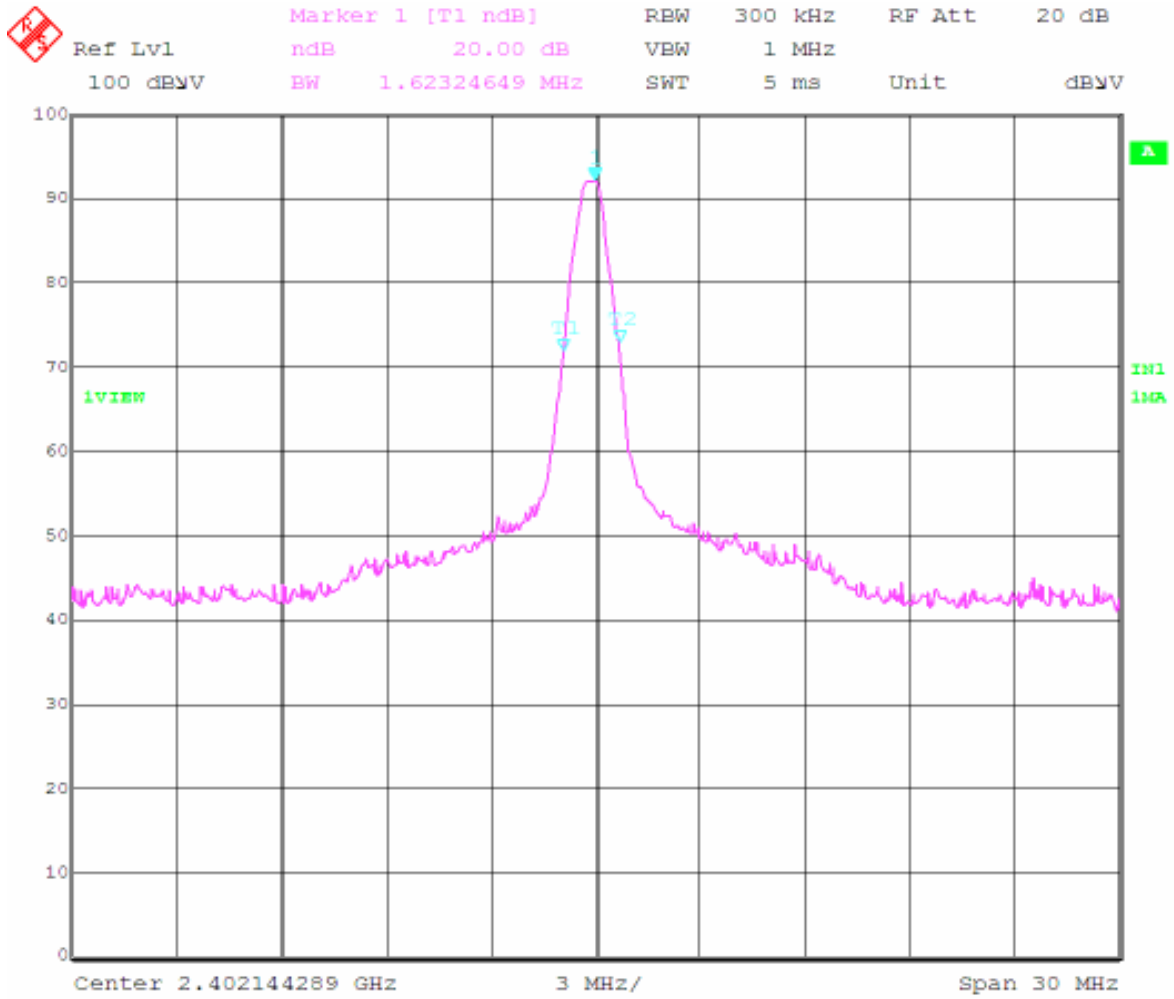

6. Photos

6.1 Setup Photo (Radiated Emission)

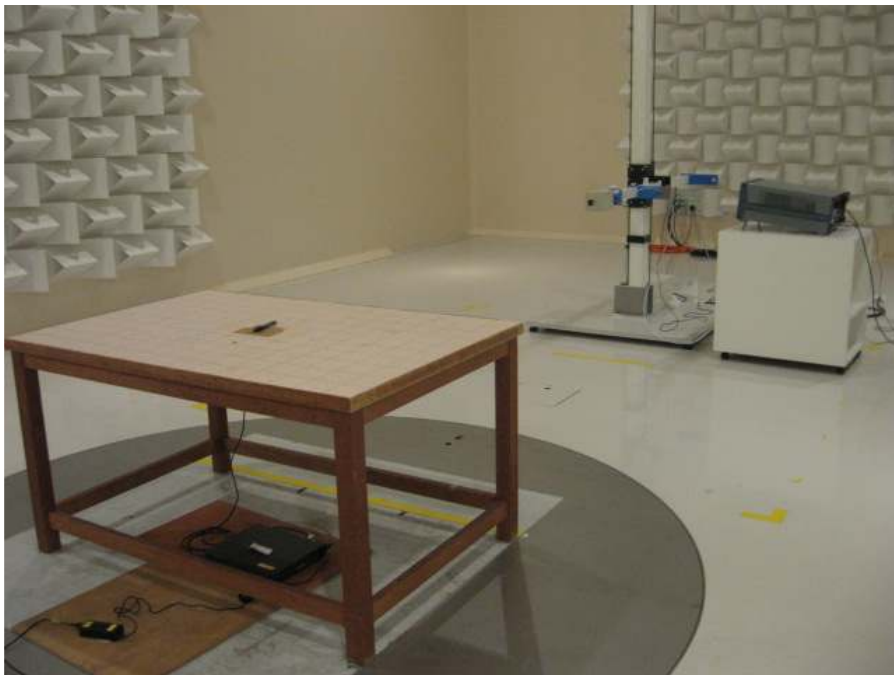
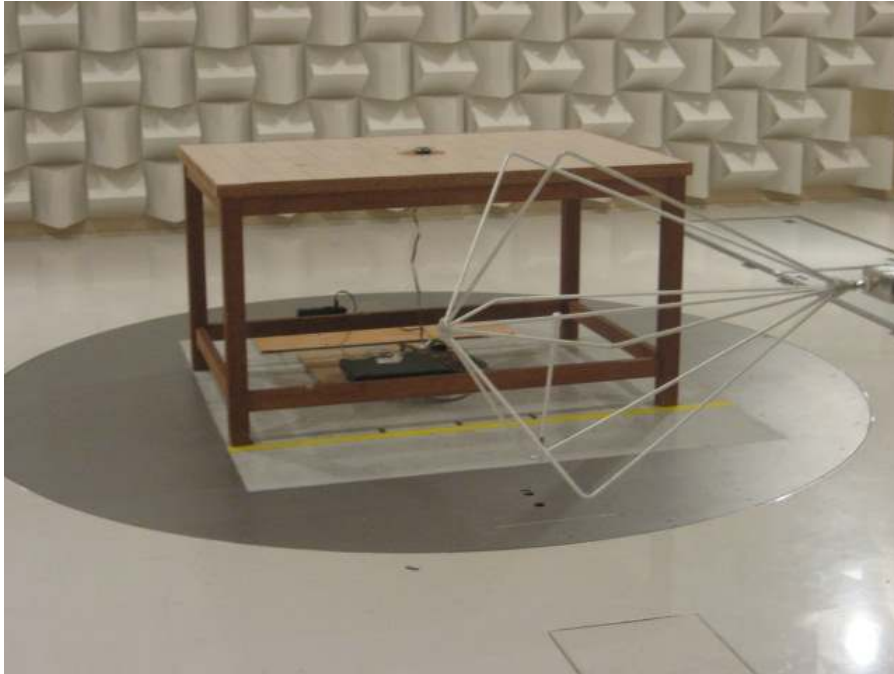

6.2 Setup Photo (Conducted Emission)



7. List of Test Measurement Instruments

7.1 Radiated Emission Measurement

Instruments	Manufacturer	Model / Type	Serial No.	Calibration Date Next Calibration
Programmable AC/DC Power Source	NF Corporation	ES18000W	425779	Confirmed Before Test
EMI Test Receiver	ROHDE& SCHWARZ	ESIB40	100211	February, 2009 February, 2010
Biconical Antenna (30to 300MHz)	SCHWARZBECK	VHBB9124(Balun) BBA9106(Elements)	9124-311	September,2008 September,2009
Log.-Periodic Antena (300MHz to1GHz)	SCHWARZBECK	UHALP9108A	645	September,2008 September,2009
Horn Antenna	SCHWARZBECK	BBHA9120D	443	September,2008 September,2009
Horn Antenna	ETS LINDGREN	3160-08	00033782	September,2008 September,2009
Horn Antenna	ETS LINDGREN	3160-09	00034723	September,2008 September,2009

7.2 AC Power Conducted Emission Measurement

Instruments	Manufacturer	Model / Type	Serial No.	Calibration Date Next Calibration
Spectrum Analyzer	ADVANTEST CORPORATION	R3132	140501174	July,2008 July,2010
EMI Test Receiver	ROHDE& SCHWARZ	ESCS30	100335	August,2008 August,2009
Artificial-Mains Network	KYORITSU CORPORATION	KNW-341C	8-1659-1	July,2008 July,2009
Transient Limiter	AGILENT TECHNOLOGIES	11947A	3107A03745	October,2008 October,2009
RF Selector	Techno Science Japan Corp.	RFM-E221	3148	Confirmed Before Test
AC Power Source	LEADER ELECTRONICS CORP.	LPS-163A	5060010	---