



TEST REPORT

Report Number : A-006-15-C

Date of Issue: 14 January 2016

FCC Rules and Regulations Part 15 Subpart C Intentional Radiators.

This test report is to certify that the device was tested according to the requirements of the above. The results of this report should not be construed to imply compliance of devices other than the sample tested. Without the laboratory approval by the documents, this report should not be copied in part.

1. Applicant

Company Name : SHIMANO INC.

Mailing Address : 3-77 Oimatsu-cho, Sakai-ku, Sakai City, Osaka, 590-8577 Japan

2. Identification of Tested Device

Type of Device : Transmitter

FCC ID : WY7-30

Device Name : Wireless Unit

Model Number : EW-WU101

Serial Number : 7G9NKA00A9B

Trade Name : SHIMANO

Type of Test : Production Pre-production Prototype

3. Test Items

AC Power Line Conducted Emission	<input type="checkbox"/> Pass	<input type="checkbox"/> Fail	<input checked="" type="checkbox"/> N/A (*2)
20dB Bandwidth and Carrier Frequency Separation (FHSS only)	<input type="checkbox"/> Pass	<input type="checkbox"/> Fail	<input checked="" type="checkbox"/> N/A (*2)
Time of Occupancy (Dwell Time) (FHSS only)	<input type="checkbox"/> Pass	<input type="checkbox"/> Fail	<input checked="" type="checkbox"/> N/A (*2)
Number of Hopping Frequency (FHSS only)	<input type="checkbox"/> Pass	<input type="checkbox"/> Fail	<input checked="" type="checkbox"/> N/A (*2)
6dB Bandwidth (DTS only)	<input type="checkbox"/> Pass	<input type="checkbox"/> Fail	<input checked="" type="checkbox"/> N/A (*2)
Peak Conducted Output Power	<input type="checkbox"/> Pass	<input type="checkbox"/> Fail	<input checked="" type="checkbox"/> N/A (*2)
Power Spectral Density (DTS only)	<input type="checkbox"/> Pass	<input type="checkbox"/> Fail	<input checked="" type="checkbox"/> N/A (*2)
Spurious Emission	<input checked="" type="checkbox"/> Pass	<input type="checkbox"/> Fail	<input type="checkbox"/> N/A

Refer the below reason(s) with respect to the decision and justification not to test.

(*1) EUT Specifications (*2) Request of Applicant (*3) According to Test Plan

KEC Electronic Industry Development Center Testing Division
3-2-2, Hikari-dai, Seika-cho, Soraku-gun, Kyoto 619-0237 Japan

Test Engineer(s)

Naoki Norimoto



Approved by

Ikuya Minematsu / Group Manager



Table of Contents

0. REVISION HISTORY 3

1. LABORATORY INFORMATION 4

 1.1. Laboratory Accreditation 4

 1.2. Test Facility 4

 1.3. Measurement Uncertainty 4

2. GENERAL INFORMATION 5

 2.1. Product Description 5

3. TESTED SYSTEM 6

 3.1. Reference Rule and Specification 6

 3.2. Date of Test 6

 3.3. Deviation of Standard 6

 3.4. Test Mode 6

 3.5. Block Diagram of TEST System 7

 3.6. List of Test System 7

 3.7. List of Cables 7

4. SPURIOUS EMISSION 8

 4.1. Test Procedure 8

 4.2. Test Software List 8

 4.3. Test Results 9

5. TEST EQUIPMENT 19

APPENDIX Photographs of EUT System Configuration 20



0. REVISION HISTORY

Report Version	Page	Description	Date of Issue	Status
A	-	Initial issue of report	14 January 2016	Original



1. LABORATORY INFORMATION

1.1. Laboratory Accreditation

The KEC has been accredited by the following organizations based on their criteria for testing laboratory (ISO/IEC 17025).

- (1) Japan Accreditation Board for Conformity Assessment (JAB) : Accreditation Number: RTL02810
 (2) Voluntary EMC Laboratory Accreditation Center Inc. (VLAC) : Accreditation Number: VLAC-005

1.2. Test Facility

All tests described in this report were performed by:

Name: KEC Electronic Industry Development Center
 Testing Division

Address: 3-2-2, Hikari-dai, Seika-cho, Soraku-gun, Kyoto 619-0237 Japan

Anechoic Chamber : No.1 No.2 No.3 No.6 No.7
 No.8 No.9 No.10 No.11 No.12
 Shielded Room : No.1 No.7 No.8 No.9 No.10
 Harmonic Current Meas. Room :

This test facility has been filed with the FCC under the criteria of ANSI C63.4-2009.

Registered Test Site Number : 174872

1.3. Measurement Uncertainty

The result of a measurement is only an approximation or estimate of the value of a specific quantity.

And thus the measurand is complete only when a statement of uncertainty is given.

KEC quotes Measurement Uncertainty (U) as follows.

Conducted Disturbance at Mains Port (150kHz-30MHz)	+2.5 / -2.8 dB
Conducted Disturbance at Mains Port (9kHz-30MHz)	+2.9 / -3.5 dB
Conducted Disturbance at Telecommunication Ports ISN method (None-Shield type)	+2.5 / -2.7 dB
Conducted Disturbance at Telecommunication Ports ISN method (Shield type)	+2.5 / -2.7 dB
Conducted Disturbance at Telecommunication Ports Current Probe method	+2.3 / -2.8 dB
Conducted Disturbance at Telecommunication Ports 150Ω Load voltage method	+2.0 / -2.6 dB
Conducted Disturbance at Telecommunication Ports None Invasive method	+2.9 / -3.9 dB
Conducted Disturbance at Lead Terminals and Additional Terminals	+1.8 / -2.1 dB
Disturbance Power (30MHz -300MHz)	+3.3 / -3.4 dB
Radiated Disturbance at Frequency Range from 9kHz up to 30MHz 60cm Loop Antenna method	+3.7 / -4.4 dB
Radiated Disturbance at Frequency Range from 9kHz up to 30MHz LLA method	+1.4 / -1.5 dB
Radiated Disturbance at Frequency Range from 30MHz up to 300MHz 3m method	+3.4 / -3.9 dB
Radiated Disturbance at Frequency Range from 300MHz up to 1GHz 3m method	+3.5 / -3.9 dB
Radiated Disturbance at Frequency Range from 30MHz up to 300MHz 10m method	+3.2 / -3.9 dB
Radiated Disturbance at Frequency Range from 300MHz up to 1GHz 10m method	+3.6 / -4.5 dB
Radiated Disturbance at Frequency Range from 30MHz up to 1GHz 10m method (Hybrid Antenna used measurement)	+4.1 / -4.6 dB
Radiated Disturbance at Frequency Range from 1GHz up to 6GHz 3m method	+4.7 / -6.0 dB
Radiated Disturbance at Frequency Range from 6GHz up to 26.5GHz 3m method	+4.5 / -5.1 dB
Harmonics Currents Emissions	+/- 5.7 %
Voltage Change, Voltage Fluctuations and Flicker	+/- 5.3 %

Expiration Date : 2016/9/30

The above values are calculated as Expanded Uncertainty (k=2 [95%]).

[Note]

If the measured result is below the specification limit and a margin is less than the above measurement uncertainty, it is impossible to determine compliance at a level of confidence of 95%. However, the measured result indicates high probability that the tested device complies with the specification limit.



2. GENERAL INFORMATION

2.1. Product Description

(1) Technical Specifications

- CPU : Frequency range: 2402MHz~2480MHz
- BLE : Output power: +4dBm
- ANT+ : Modulation: GFSK
- ANT+ : Frequency range: 2403MHz~2480MHz
- ANT+ : Output power: +4dBm
- ANT+ : Modulation: GFSK
- ANT+ : Antenna gain: PCB antenna with -1.5dBi gain

(2) Maximum Oscillators Frequency

- Clock Generator for CPU : 16MHz

(3) Software Version

- nRF Master Control Panel application : 3.10.0

(4) Firmware Version

- Radiation test : ble_ant_all_WR6.hex
- Radiation test : ble_ant_app_WR6.hex
- Radiation test : EWWU101_RFTEST.3.15.128.dat
- Radiation test : SMBMR2.4.15.128.dat

(5) Interface and Provide Terminal

- Connector : Communication

(6) Rated Power Supply

- : DC 7.4V
- (Test for DC 7.4V)

3. TESTED SYSTEM

3.1. Reference Rule and Specification

(1) Reference Rule and Regulation	: FCC Rule Part 15 Subpart C, Section 15.247 Operation within the bands 902-928MHz, 2400-2483.5MHz, 5725-5850MHz <input checked="" type="checkbox"/> Section 15.205 <input type="checkbox"/> Section 15.207 <input checked="" type="checkbox"/> Section 15.209 <input type="checkbox"/> Section 15.247 (a)(1) <input type="checkbox"/> Section 15.247 (a)(2) <input checked="" type="checkbox"/> Section 15.247 (b)(1) <input checked="" type="checkbox"/> Section 15.247 (b)(3) <input checked="" type="checkbox"/> Section 15.247 (d) <input type="checkbox"/> Section 15.247 (e)
(2) Test Procedure	: ANSI C63.10-2013 FCC Public Notice DA 00-705 KDB Publication No.558074 D01 DTS Meas Guidance V03r03

3.2. Date of Test

Receipt of Test Sample : 17 December 2015
 Condition of Test Sample : Damage is not found on the set.
 Damage is found on the set. (Details are described in this report)

Test Completed on : 5 January 2016
 Condition of Test Sample : Damage is not found on the set.
 Damage is found on the set. (Details are described in this report)

3.3. Deviation of Standard

without deviation, with deviation (details are found inside of this report)

3.4. Test Mode

•ANT+

Test Item	Test Frequency
Spurious Emissions / Restricted Band Edges	2403MHz
	2441MHz
	2480MHz

•BLE

Test Item	Test Frequency
Spurious Emissions / Restricted Band Edges	2402MHz
	2440MHz
	2480MHz

[Note]

- (1) The power setting was performed with the maximum output level.
- (2) The test program was prepared by applicant.
- (3) The spurious emissions data of the each modes were checked in three orthogonal axes, and the data of the producing the maximum emissions were reported at each frequency.

3.5. Block Diagram of TEST System

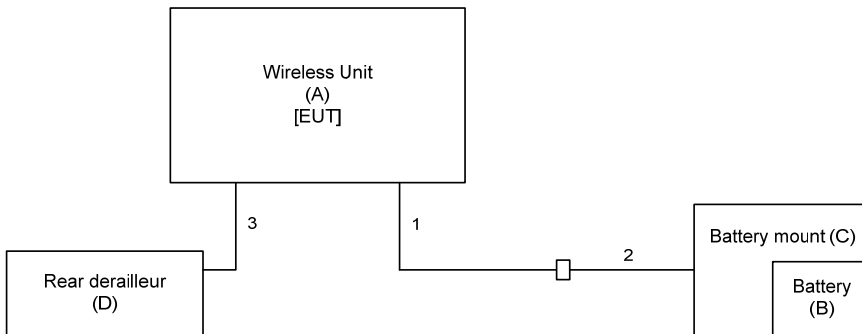

3.6. List of Test System

No.	Device Name	Model Number	Serial Number	Trade Name	Note
A	Wireless Unit	EW-WU101	7G9NKA00A9B	SHIMANO	EUT
B	Battery	SM-BTR1	7DHNFK0054D	SHIMANO	
C	Battery mount	SM-BMR2	7FKNHN01731	SHIMANO	
D	Rear derailleur	RD-9070	5Y8NJS010D80	SHIMANO	

[Note]

(1): Option of EUT

3.7. List of Cables

No.	Cable Name	Shielded (Y/N)	Length (m)	Note
1	Signal Cable	Y	0.7	Model No. :EW-SD50
2	Signal Cable	Y	0.4	Model No. :EW-SD50
3	Signal Cable	Y	0.15	Model No. :EW-SD50

[Note]

(1) : Undetachable cable type

(2) : Accessories cable of EUT

(3) : 3-wires type, earth plug is grounded

(4) : 2-wires type

4. SPURIOUS EMISSION

4.1. Test Procedure

<p>Radiated measurement</p> <p>(1) The EUT is placed in accordance with ANSI C63.10.</p> <p>(2) The EUT is activated as to simulate an worst datarate.</p> <p>(3) To find out the maximum emission of the configuration of the EUT System, the position of the cables are changed, then preliminary radiated measurement are performed using the spectrum analyzer ,the broad band antenna and the horn antenna.</p> <p>(4) The spectrums are scanned from 30MHz to 1GHz, and collect the highest emissions on the spectrum analyzer (*1) relative to the limits in the whole range. In the frequency above 1GHz, it is performed using the spectrum analyzer (*1) and the horn antenna.</p> <p>(5) The highest emissions are measured at the specified distance using the test receiver (*2) and the broad band antenna or the tuned dipole. In the frequency above 1GHz, the measurements are performed by Bore-sight method using the spectrum analyzer (*3) and the horn antenna (*4).</p>														
<p>[Note]</p> <p>(*1) Spectrum Analyzer Set Up Conditions (Pre-measurement)</p> <p>Frequency range : 30MHz – 1GHz / 1GHz – Upper frequency of measurement range</p> <p>Resolution bandwidth : 100kHz (6dB Bandwidth)/ 1MHz(Impulse Bandwidth)</p> <p>Detector function : Peak</p> <p>(*2) Test Receiver Set Up Conditions</p> <p>Detector function : Quasi – Peak</p> <p>IF bandwidth : 120kHz(6dB Bandwidth)</p> <p>(*3) Peak measurement Set Up Conditions</p> <p>Resolution bandwidth : 1MHz(Impulse Bandwidth)</p> <p>Video bandwidth : 3 x RBW</p> <p>Detector function : Peak</p> <p>Average measurement Set Up Conditions</p> <p>Resolution bandwidth : 1MHz(Impulse Bandwidth)</p> <p>Video bandwidth : 3 x RBW (DTS) / 10Hz (FHSS)</p> <p>Detector function : RMS (DTS) / Peak (FHSS)</p> <p>Trace : Trace Average 100 times (DTS)</p> <p>Y axis : Linear (FHSS)</p> <p>Non-Restricted Band measurement Set Up Conditions</p> <p>Resolution bandwidth : 100kHz(6dB Bandwidth)</p> <p>Video bandwidth : 3 x RBW</p> <p>Detector function : Peak</p> <p>(*4) Cover Area of Horn Antenna (3dB Beamwidth)</p> <table border="1"> <thead> <tr> <th>Frequency [GHz]</th> <th>Cover Area [m] at distance 3m</th> <th>Cover Area [m] at distance 1m</th> </tr> </thead> <tbody> <tr> <td>1.0-6.0</td> <td>1.89</td> <td>-</td> </tr> <tr> <td>5.8-12.4</td> <td>0.63</td> <td>0.21</td> </tr> <tr> <td>12.4-40.0</td> <td>0.47</td> <td>0.16</td> </tr> </tbody> </table>			Frequency [GHz]	Cover Area [m] at distance 3m	Cover Area [m] at distance 1m	1.0-6.0	1.89	-	5.8-12.4	0.63	0.21	12.4-40.0	0.47	0.16
Frequency [GHz]	Cover Area [m] at distance 3m	Cover Area [m] at distance 1m												
1.0-6.0	1.89	-												
5.8-12.4	0.63	0.21												
12.4-40.0	0.47	0.16												

4.2. Test Software List

KEC No.	Software Name	Version	Manufacture
TF-059	TEPTO Radiated emission automatic measurement	2.3.0321	TSJ
TF-110	Junction sheet	1.6H	KEC



4.3. Test Results

• ANT+
2403MHz

Measured Frequency (MHz)	Correction Factor (dB/m)	Meter Reading		Distance Factor from 1m to 3m (dB)	Maximum Field Strength (dBμV/m)	Limit (dBμV/m)	Margin for Limit (dB)
		Horizontal Polarization (dBμV)	Vertical Polarization (dBμV)				
Peak measurement							
2330.55	-3.3	57.6	60.0	-	56.7	74.0	17.3
2390.00	5.6	<45.0	<45.0	-	<50.6	74.0	>23.4
4806.00	2.4	<45.0	<45.0	-	<47.4	74.0	>26.6
7209.00	1.6	<45.0	<45.0	-	<46.6	74.0	>27.4
24030.00	13.1	<45.0	<45.0	9.5	<48.3	74.0	>25.7

Measured Frequency (MHz)	Correction Factor (dB/m)	Meter Reading		Distance Factor from 1m to 3m (dB)	Maximum Field Strength (dBμV/m)	Limit (dBμV/m)	Margin for Limit (dB)
		Horizontal Polarization (dBμV)	Vertical Polarization (dBμV)				
Average measurement							
2330.55	-3.3	<35.0	<35.0	-	<31.7	54.0	>22.3
2390.00	5.6	<35.0	<35.0	-	<40.6	54.0	>13.4
4806.00	2.4	<35.0	<35.0	-	<37.4	54.0	>16.6
7209.00	1.6	<35.0	<35.0	-	<36.6	54.0	>17.4
24030.00	13.1	<35.0	<35.0	9.5	<38.6	54.0	>15.4

[20dBc Data Sheet]

Measured Frequency (MHz)	Antenna Factor (dB/m)	Meter Reading		Maximum Field Strength (dBμV/m)	Limit (dBμV/m)	Margin for Limit (dB)
		Horizontal Polarization (dBμV)	Vertical Polarization (dBμV)			
Peak measurement						
2403.00	5.6	87.5	-	93.1	-	-
2400.00	5.6	37.6	-	43.2	73.1	29.9
2403.00	5.6	-	86.7	92.3	-	-
2400.00	5.6	-	33.7	39.3	72.3	33.0



2441MHz

Measured Frequency (MHz)	Correction Factor (dB/m)	Meter Reading		Distance Factor from 1m to 3m (dB)	Maximum Field Strength (dB μ V/m)	Limit (dB μ V/m)	Margin for Limit (dB)
		Horizontal Polarization (dB μ V)	Vertical Polarization (dB μ V)				
Peak measurement							
4882.00	2.8	<45.0	<45.0	-	<47.8	74.0	>26.2
7323.00	1.9	<45.0	<45.0	-	<46.9	74.0	>27.1
24410.00	13.1	<45.0	<45.0	9.5	<58.1	74.0	>15.9

Measured Frequency (MHz)	Correction Factor (dB/m)	Meter Reading		Distance Factor from 1m to 3m (dB)	Maximum Field Strength (dB μ V/m)	Limit (dB μ V/m)	Margin for Limit (dB)
		Horizontal Polarization (dB μ V)	Vertical Polarization (dB μ V)				
Average measurement							
4882.00	2.8	<35.0	<35.0	-	<37.8	54.0	>16.2
7323.00	1.9	<35.0	<35.0	-	<36.9	54.0	>17.1
24410.00	13.1	<35.0	<35.0	9.5	<38.6	54.0	>15.4



2480MHz

Measured Frequency (MHz)	Correction Factor (dB/m)	Meter Reading		Distance Factor from 1 m to 3 m (dB)	Maximum Field Strength (dBμV/m)	Limit (dBμV/m)	Margin for Limit (dB)
		Horizontal Polarization (dBμV)	Vertical Polarization (dBμV)				
Peak measurement							
2483.50	5.5	<45.0	<45.0	-	<50.5	74.0	>23.5
2572.98	-1.0	56.6	57.6	-	56.6	74.0	17.4
4960.00	2.2	<45.0	<45.0	-	<47.2	74.0	>26.8
7440.00	1.7	<45.0	<45.0	-	<46.7	74.0	>27.3
24800.00	13.7	<45.0	<45.0	9.5	<49.2	74.0	>24.8

Measured Frequency (MHz)	Correction Factor (dB/m)	Meter Reading		Distance Factor from 1 m to 3 m (dB)	Maximum Field Strength (dBμV/m)	Limit (dBμV/m)	Margin for Limit (dB)
		Horizontal Polarization (dBμV)	Vertical Polarization (dBμV)				
Average measurement							
2483.50	5.5	<35.0	<35.0	-	<40.5	54.0	>13.5
2572.98	-1.0	<35.0	<35.0	-	<34.0	54.0	>20.0
4960.00	2.2	<35.0	<35.0	-	<37.2	54.0	>16.8
7440.00	1.7	<35.0	<35.0	-	<36.7	54.0	>17.3
24800.00	13.7	<35.0	<35.0	9.5	<39.2	54.0	>14.8

[20dBc Data Sheet]

Measured Frequency (MHz)	Antenna Factor (dB/m)	Meter Reading		Maximum Field Strength (dBμV/m)	Limit (dBμV/m)	Margin for Limit (dB)
		Horizontal Polarization (dBμV)	Vertical Polarization (dBμV)			
Peak measurement						
2480.00	5.5	86.9	-	92.4	-	-
2483.50	5.5	33.6	-	39.1	72.4	33.3
2480.00	5.5	-	83.8	89.3	-	-
2483.50	5.5	-	33.4	38.9	69.3	30.4



• BLE
2402MHz

Measured Frequency (MHz)	Correction Factor (dB/m)	Meter Reading		Distance Factor from 1m to 3m (dB)	Maximum Field Strength (dBµV/m)	Limit (dBµV/m)	Margin for Limit (dB)
		Horizontal Polarization (dBµV)	Vertical Polarization (dBµV)				
Peak measurement							
2325.58	-3.5	63.9	60.9	-	60.4	74.0	13.6
2390.00	5.6	<45.0	<45.0	-	<50.6	74.0	>23.4
4804.00	2.4	<45.0	<45.0	-	<47.4	74.0	>26.6
7206.00	1.6	<45.0	<45.0	-	<46.6	74.0	>27.4
24020.00	13.1	<45.0	<45.0	9.5	<48.6	74.0	>25.4

Measured Frequency (MHz)	Correction Factor (dB/m)	Meter Reading		Distance Factor from 1m to 3m (dB)	Duty Cycle Factor (dB)	Maximum Field Strength (dBµV/m)	Limit (dBµV/m)	Margin for Limit (dB)
		Horizontal Polarization (dBµV)	Vertical Polarization (dBµV)					
Average measurement								
2325.58	-3.5	<35.0	<35.0	-	-	<31.5	54.0	>22.5
2390.00	5.6	<35.0	<35.0	-	-	<40.6	54.0	>13.4
4804.00	2.4	<35.0	<35.0	-	1.6	<39.0	54.0	>15.0
7206.00	1.6	<35.0	<35.0	-	1.6	<38.2	54.0	>15.8
24020.00	13.1	<35.0	<35.0	9.5	1.6	<40.2	54.0	>13.8

[20dBc Data Sheet]

Measured Frequency (MHz)	Antenna Factor (dB/m)	Meter Reading		Maximum Field Strength (dBµV/m)	Limit (dBµV/m)	Margin for Limit (dB)
		Horizontal Polarization (dBµV)	Vertical Polarization (dBµV)			
Peak measurement						
2400.00	5.6	41.6	-	47.2	74.6	27.4
2402.00	5.6	89.0	-	94.6	-	-
2400.00	5.6	-	39.5	45.1	70.8	25.7
2402.00	5.6	-	85.2	90.8	-	-



2440MHz

Measured Frequency (MHz)	Correction Factor (dB/m)	Meter Reading		Distance Factor from 1m to 3m (dB)	Maximum Field Strength (dB μ V/m)	Limit (dB μ V/m)	Margin for Limit (dB)
		Horizontal Polarization (dB μ V)	Vertical Polarization (dB μ V)				
Peak measurement							
4880.00	2.8	<45.0	<45.0	-	<47.8	74.0	>26.2
7320.00	1.9	<45.0	<45.0	-	<46.9	74.0	>27.1
24400.00	13.1	<45.0	<45.0	9.5	<58.1	74.0	>15.9

Measured Frequency (MHz)	Correction Factor (dB/m)	Meter Reading		Distance Factor from 1m to 3m (dB)	Duty Cycle Factor (dB)	Maximum Field Strength (dB μ V/m)	Limit (dB μ V/m)	Margin for Limit (dB)
		Horizontal Polarization (dB μ V)	Vertical Polarization (dB μ V)					
Average measurement								
4880.00	2.8	<35.0	<35.0	-	1.6	<39.4	54.0	>14.6
7320.00	1.9	<35.0	<35.0	-	1.6	<38.5	54.0	>15.5
24400.00	13.1	<35.0	<35.0	9.5	1.6	<40.2	54.0	>13.8



2480MHz

Measured Frequency (MHz)	Correction Factor (dB/m)	Meter Reading		Distance Factor from 1m to 3m (dB)	Maximum Field Strength (dBμV/m)	Limit (dBμV/m)	Margin for Limit (dB)
		Horizontal Polarization (dBμV)	Vertical Polarization (dBμV)				
Peak measurement							
2483.50	5.5	<45.0	<45.0	-	<50.5	74.0	>23.5
2565.13	-0.8	54.0	53.5	-	53.2	74.0	20.8
4960.00	2.2	<45.0	<45.0	-	<47.2	74.0	>26.8
7440.00	1.7	<45.0	<45.0	-	<46.7	74.0	>27.3
24800.00	13.7	<45.0	<45.0	9.5	<49.2	74.0	>24.8

Measured Frequency (MHz)	Correction Factor (dB/m)	Meter Reading		Distance Factor from 1m to 3m (dB)	Duty Cycle Factor (dB)	Maximum Field Strength (dBμV/m)	Limit (dBμV/m)	Margin for Limit (dB)
		Horizontal Polarization (dBμV)	Vertical Polarization (dBμV)					
Average measurement								
2483.50	5.5	<35.0	<35.0	-	-	<40.5	54.0	>13.5
2565.13	-0.8	<35.0	<35.0	-	-	<34.2	54.0	>19.8
4960.00	2.2	<35.0	<35.0	-	1.6	<38.8	54.0	>15.2
7440.00	1.7	<35.0	<35.0	-	1.6	<38.3	54.0	>15.7
24800.00	13.7	<35.0	<35.0	9.5	1.6	<40.8	54.0	>13.2

[20dBc Data Sheet]

Measured Frequency (MHz)	Antenna Factor (dB/m)	Meter Reading		Maximum Field Strength (dBμV/m)	Limit (dBμV/m)	Margin for Limit (dB)
		Horizontal Polarization (dBμV)	Vertical Polarization (dBμV)			
Peak measurement						
2480.00	5.5	85.6	-	91.1	-	-
2483.50	5.5	33.9	-	39.4	71.1	31.7
2480.00	5.5	-	82.0	87.5	-	-
2483.50	5.5	-	33.1	38.6	67.5	28.9



[Remark]

*1) : Carrier

[Note]

(1) Correction Factor includes the antenna factor, cable loss, attenuator loss and pre-amplifier gain.
 Correction Factor includes the cable loss and attenuator loss.
 Above 1000MHz, the antenna factor includes the cable loss, pre-amplifier gain and attenuator loss (if necessary).

(2) * mark in Measured Frequency : Measured with the tuned dipole antenna.
 no mark in Measured Frequency : Measured with the broadband antenna.

(3) Upper Frequency : Transmitter Frequency (TX): TX < 10GHz
 1GHz 10th harmonic of the highest frequency / Up to 40GHz
 Transmitter Frequency (TX): 10GHz ≤ TX < 30GHz
 10th harmonic of the highest frequency / Up to 100GHz
 Transmitter Frequency (TX): 30GHz ≤ TX
 10th harmonic of the highest frequency / Up to 200GHz

The emissions were checked to the upper frequency, and the lower emissions than the listed emissions in the above tables were omitted.

(4) Measurement Distance : <below 1GHz> 3m 10m
 <above 1GHz> 3m 10m
 <above 12.4GHz> 1m

(5) Bore-sight method setting : horn antenna orientation was center of Turn Table

[Calculation method]

Maximum Field Strength (dBμV/m)

= Meter Reading (at maximum level of Horizontal or Vertical) (dBμV) + Correction Factor (dB/m) – Distance factor(dB) (*) + Duty Cycle Factor (dB) (**)

(*) Applied for Radiated Emission Measurement (above 12.4GHz) only.

Distance factor : $20 \times \log_{10} (3\text{m}/1\text{m}) = 9.5\text{dB}$

(**) See next page

Tested Date	Environment	
	Temperature	Humidity
5 January 2016	20°C	35 %

Duty Cycle

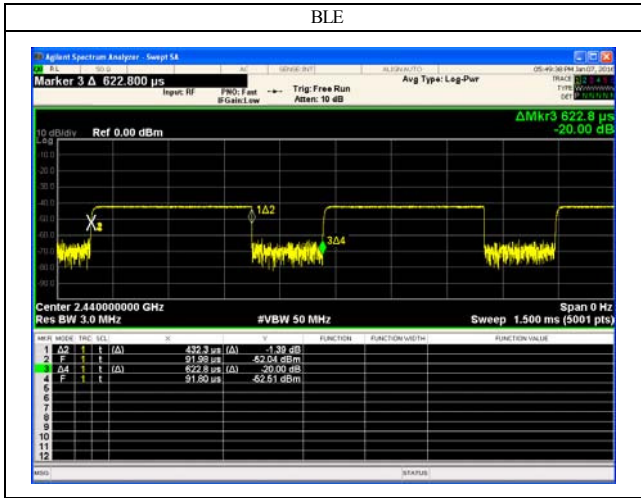

	BLE
Tx on	432.3
Tx on + Tx off	622.8
Duty Cycle	0.69
Duty Cycle Factor (dB)	1.59

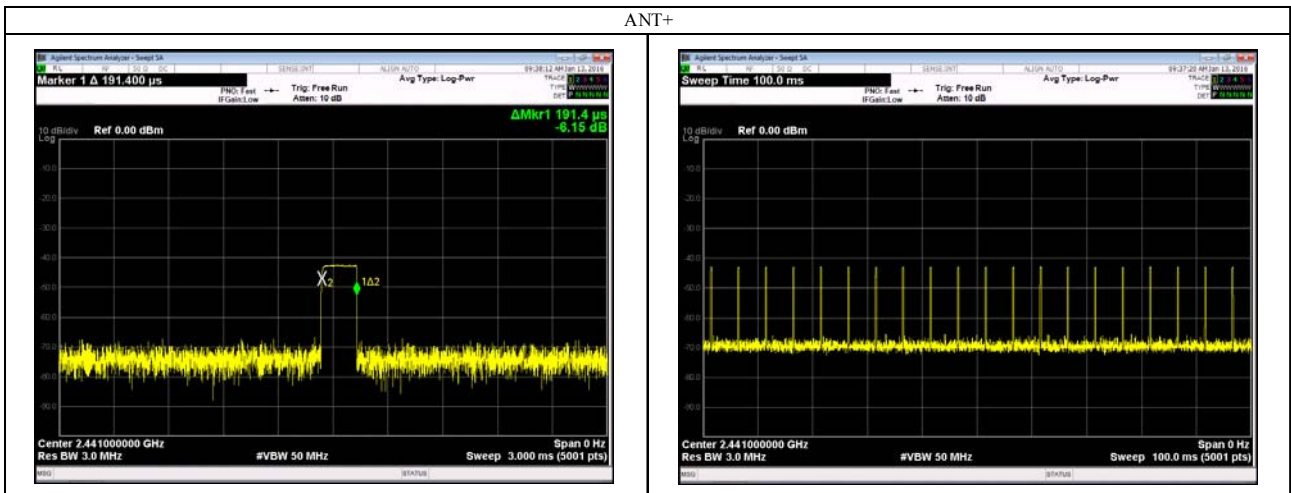

$$\begin{aligned}
 \text{Duty Cycle Factor (dB)} &= 20 \log_{10} (\text{number of hits} \times (\text{Tx on time} / 100\text{ms})) \\
 &= 20 \log_{10} (20 \times (0.1914\text{ms} / 100\text{ms})) \\
 &= -28.34 \text{ (dB)}
 \end{aligned}$$



Below 1GHz (9k-30MHz)

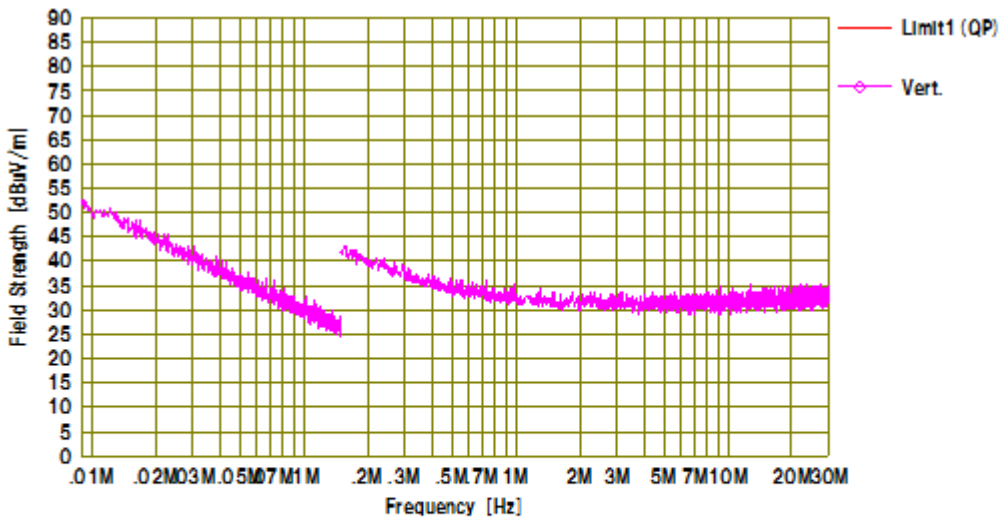
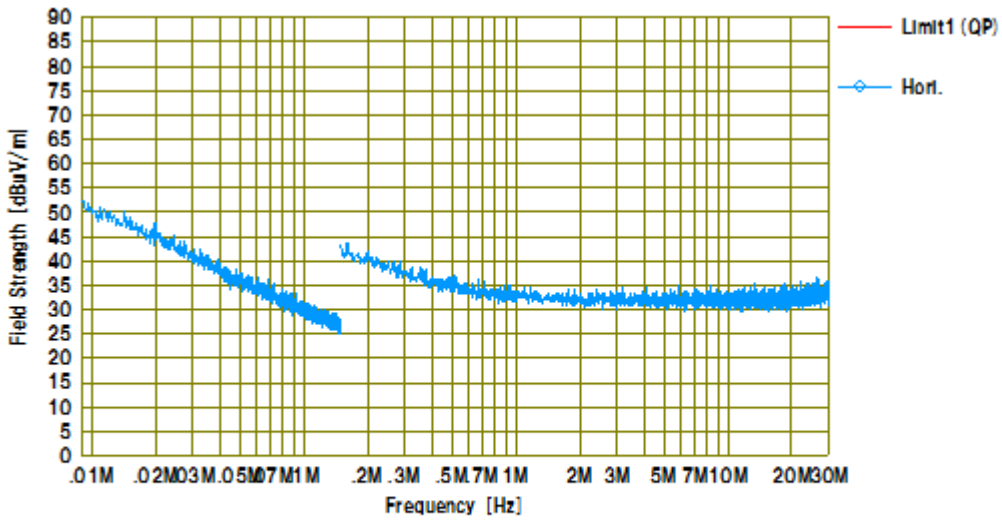



Below 1GHz (30-1000MHz)

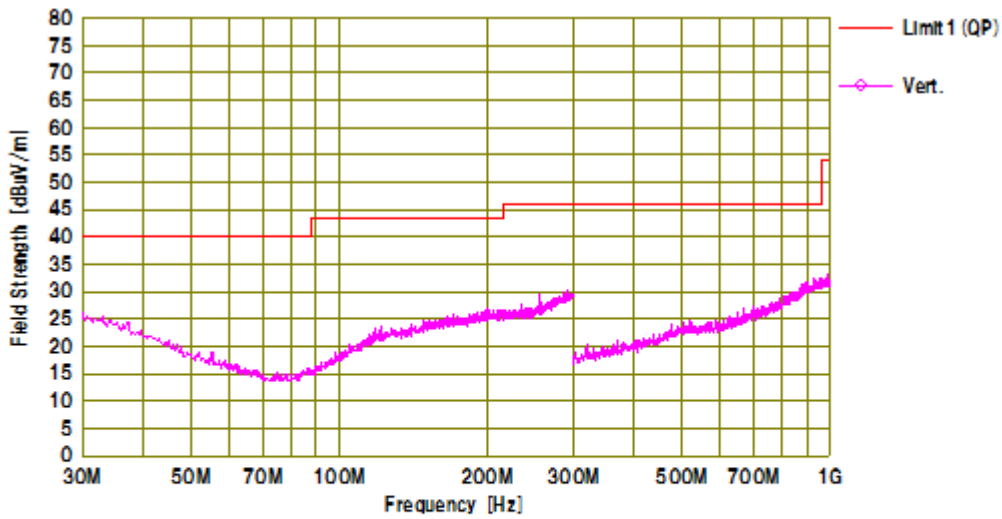
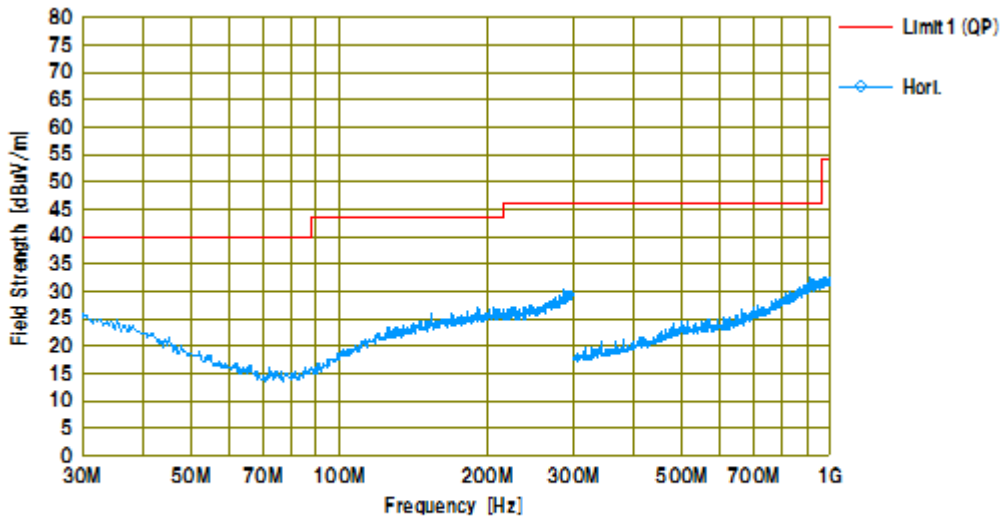



5. TEST EQUIPMENT

Spurious Emissions Measurement (Radiated measurement) below 30 MHz

KEC No.	Equipment	Manufacturer	Model No.	Last Cal.	Next Cal.
AN-054	Loop Antenna	ROHDE & SCHWARZ	HFH2-Z2	2014/04	2016/04
SA-062	Test Receiver	Agilent Technologies	N9038A	2015/04	2016/04

· Spurious Emissions Measurement (Radiated measurement) 30 -1000 MHz

KEC No.	Equipment	Manufacturer	Model No.	Last Cal.	Next Cal.
AM-028	Pre-Amplifier	Anritsu	MH648A	2015/04	2016/04
AN-094	Biconical Antenna	Schwarzbeck	VHA9103/BBA9106	2015/04	2016/04
AN-217	LPDA Antenna	Schwarzbeck	UHALP 9108A	2015/04	2016/04
AT-159	Fixed Attenuator	Anritsu	MP721B	2015/04	2016/04
FS-079	Test Receiver	ROHDE & SCHWARZ	ESVD	2015/12	2016/11
MM-530	RF Relay Matrix Unit	TSJ	RFM-E321	2015/04	2016/04
SA-059	Spectrum Analyzer	Agilent	N9010A	2015/07	2016/07

· Spurious Emissions Measurement (Radiated measurement) above 1GHz

KEC No.	Equipment	Manufacturer	Model No.	Last Cal.	Next Cal.
AM-053	Pre-Amplifier	HP	8449B	2015/04	2016/04
AN-104	Std. Gain Horn Antenna	Scientific-Atlanta	12-5.8	2015/04	2017/04
AN-107	Std. Gain Horn Antenna	Scientific-Atlanta	12A-18	2013/12	2016/01
AN-145	Std. Gain Horn Antenna	Scientific-Atlanta	12-12	2015/04	2017/04
AN-210	Std. Gain Horn Antenna	Scientific-Atlanta	12-8.2	2015/04	2017/04
AN-298	DRG Horn Antenna	Schwarzbeck	BBHA9120LF(A)	2015/04	2016/04
SA-052	Spectrum Analyzer	Agilent	E4446A	2015/10	2016/10
FL-222	Band-stop Filter	TOYO	8BRM2442/T300	2015/04	2016/04
AT-148	Fixed Attenuator	Anritsu	41KC-10	2015/06	2016/04

Note : (*1) We check the performance, before using this device.

The overall program of calibration and verification of equipment is designed and operated so as to ensure that measurements made by KEC are traceable to national standards of measurement or equivalent abroad.