



WHA YU INDUSTRIAL CO., LTD. (HEAD OFFICE)
 DONGGUAN AEON TECH CO.,LTD.(CHINA)
 TAI HWA ELECTRONIC CO., LTD.(CHINA)
 SHANGHAI HUA YU ELECTRONIC CO., LTD.(CHINA)
 SU ZHOU AEON TECH CO., LTD. (CHINA)

SPECIFICATION FOR APPROVAL

CUSTOMER: 中磊電子股份有限公司

PART NAME: RF Antenna Assembly

PART NO.: 61721006WY **REVISION:**

W. Y. P/NO.: C147-510336-A **REV.:** X3

	MANUFACTURER SIGNATURE	CUSTOMER SIGNATURE
APPROVED BY :	吳忠孝 	
DATE :	4/25-2007	

WHA YU GROUP

WHA YU INDUSTRIAL CO., LTD.(HEAD OFFICE)

譚裕實業股份有限公司

Address: No. 326, Sec. 2, Kung Tao 5 Road, Hsin Chu City, Taiwan, R.O.C.

Tel: +886-3-5714225(REP.) Fax: + 886-3-5713853 · + 886-3-5723600

DONGGUAN AEON TECH CO.,LTD.(CHINA)

東莞台霖電子通訊有限公司

Address: Lakeside Industrial Park, Da Ling Shan Town, Dong Guan City, Guangdong, China

Tel: + 86-769-85655858 Fax: + 86-769-8565525

TAI HWA ELECTRONIC FACTORY

台樺電業製品廠

Address: Pak Ho District, Hou Street Town, Dong Guan City, Guangdong, China

Tel: + 86-769-85599375 · + 86-769-85912375 Fax: + 86-769-85599376

HUA HONG INTERNATIONAL LTD.

華弘國際有限公司

Address: Rm.1103A, President Commercial Centre, 608 Nathan Road, Mong Kok, Kowloon, Hong Kong

Tel: + 86-852-27712210 Fax: + 86-852-23843747

SHANGHAI HUA YU ELECTRONIC CO., LTD. (CHINA)

上海譚裕電子有限公司

Address: 3586, Wai Qing Song Road, Qing Pu County, Shanghai China

Tel: + 86-21-59741348 · + 86-21-59744101-4 Fax: + 86-21-59741347

SU ZHOU AEON TECH CO., LTD. (CHINA)

蘇州華廣電通有限公司

Address: Limin North Road, LiLi Town, LiLi Industrial Park, LinHu Economic Zone

Wujiang City, Jiangsu Province, China

Tel: + 86-512-63627980 Fax: + 86-512-63627981

Contents

<i>Item</i>	<i>Description</i>	<i>Page</i>
1.	規格表 1
2.	成品圖 2
3.	測試報告 3~5
4.	Cable 規格 6~8
5.	SGS 測試 9~30
6.	RoHS 排外條款 31

PIFA Antenna Assembly

Specification

1. Electrical Properties :

- 1.1 Frequency Range..... 2.4GHz ~ 2.5GHz
- 1.2 Impedance 50 Nominal
- 1.3 VSWR 3.0 : 1 Max.
- 1.4 Return Loss..... -6.0dB Max
- 1.5 Efficiency..... 50%
- 1.6 Polarization..... Linear Vertical
- 1.7 Admitted Power..... 1W
- 1.8 Cable..... 1.13mm Coaxial Cable

2. Physical Properties :

- 2.1 Operating Temp. -10 ~ +60
- 2.2 Storage Temp. -10 ~ +70

CG-

REV	DATE	DESCRIPTION
X1	1/19-2007	New Issue
X2	03/12-2007	Change Length
X3	04/24-2007	Add Adhesive tape

Detail A

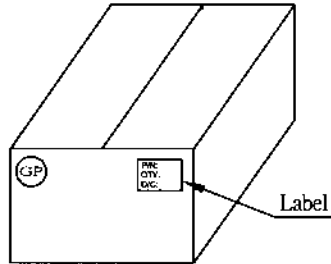
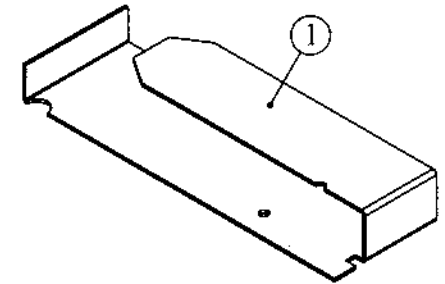
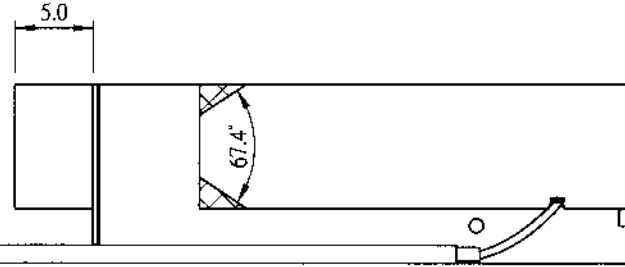
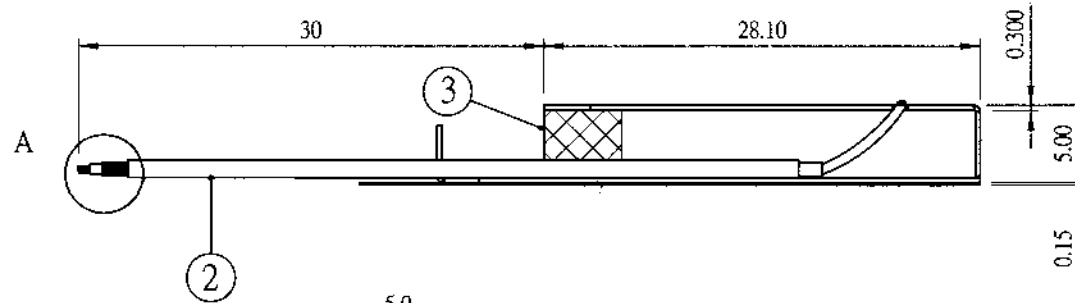
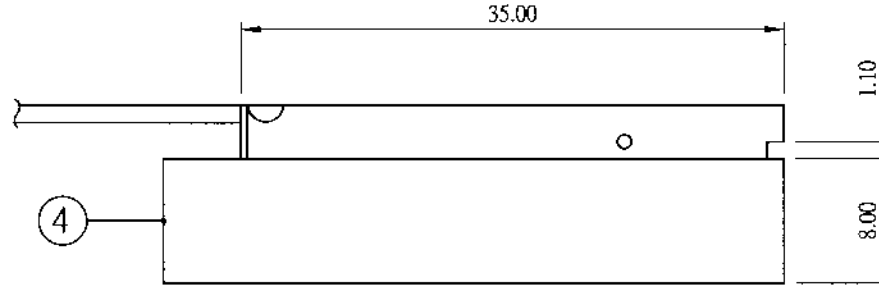
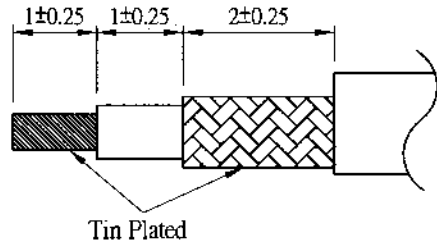

GP標籤貼於外箱兩邊側面左上角共2PCS
標示Label貼於外箱兩邊側面共2PCS

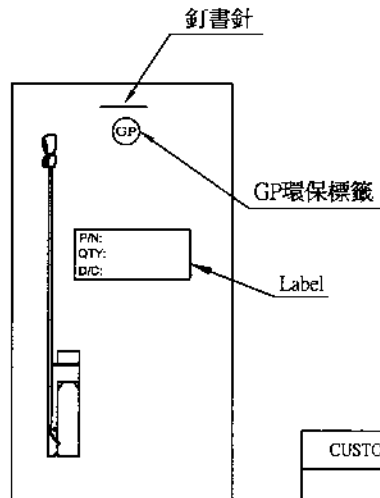

Packing : 1 pcs/bag
(每10袋用釘書機訂起來)

4	Adhesive Tape	L35*W8*T0.15mm	1	
3	Sponge	EVA ; L7*W4*T5mm	1	
2	Cable	∅1.13 Coaxial Cable ; Gray	1	
1	PIFA	Copper	1	
NO	DESCRIPTION		QTY	REMARK

XX	±5	APPROVED	<i>[Signature]</i>
X	±3.0	CHECKED	<i>[Signature]</i>
.X	±1.0	DRAWING	<i>[Signature]</i>
.XX	±0.5		
.XXX	±0.1		

CUSTOMER:		中磊	
PART NO :	61721006WY		
PARTNAME:	PIFA Antenna		
W.Y PNO :	C147-510336-A		
REV	UNIT	FILE :	
X3	m/m	SHEET :	1/1

CUSTOMER'S SIGNATURE

M.gear Wha Yu Group

THIS DRAWING, AND ITS INHERANT DESIGN CONCEPTS, ARE THE PROPERTY OF WHA YU AND AS SUCH MAY NOT BE COPIED, REPRODUCED, OR GIVEN TO THIRD PARTIES WITHOUT THE WRITTEN CONSENT OF WHA YU.

一、3D Chamber 場型測試
1. 環境圖示

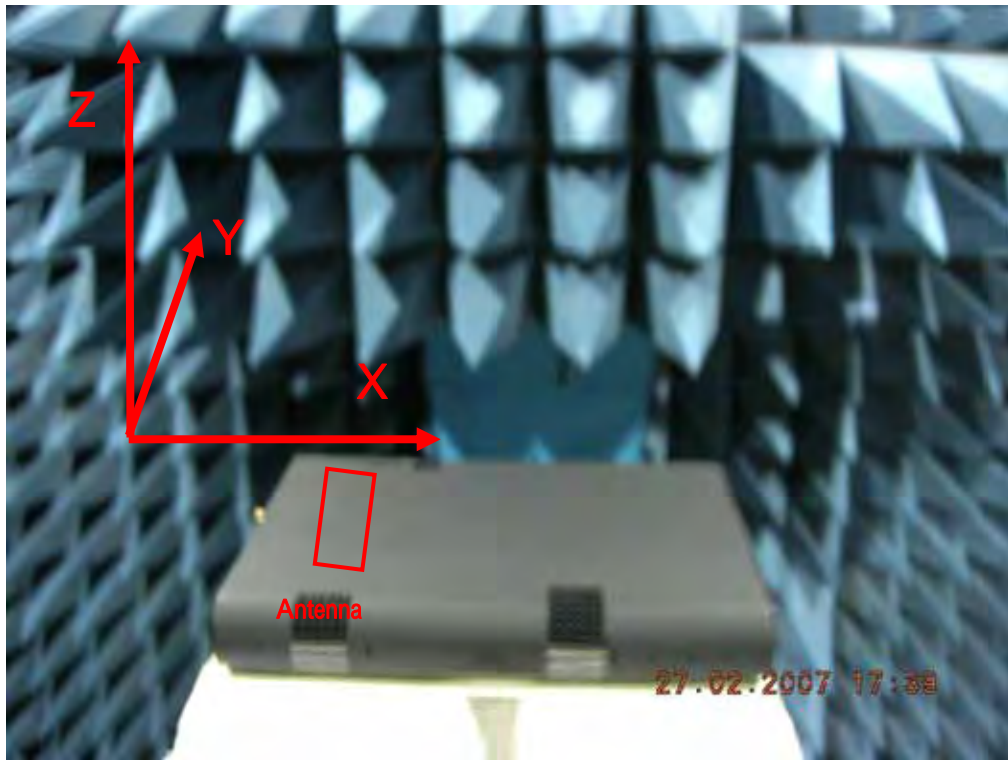

二、 Antenna WY -With PCB Shielding 電測

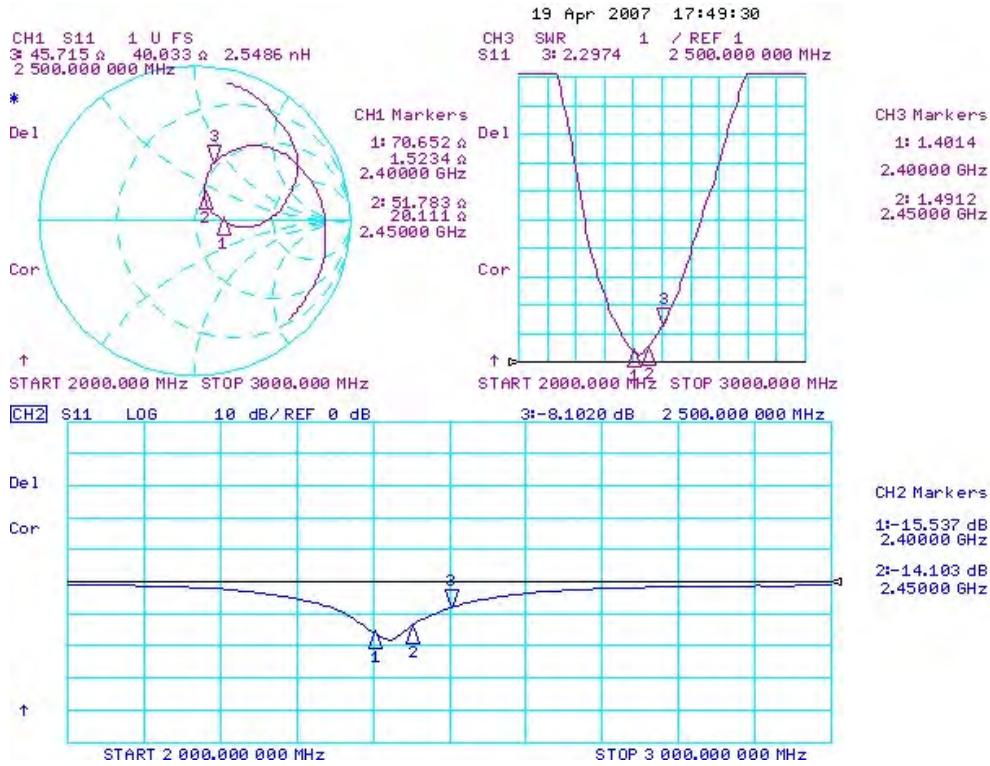

三、 Antenna WY -Free Space 電測

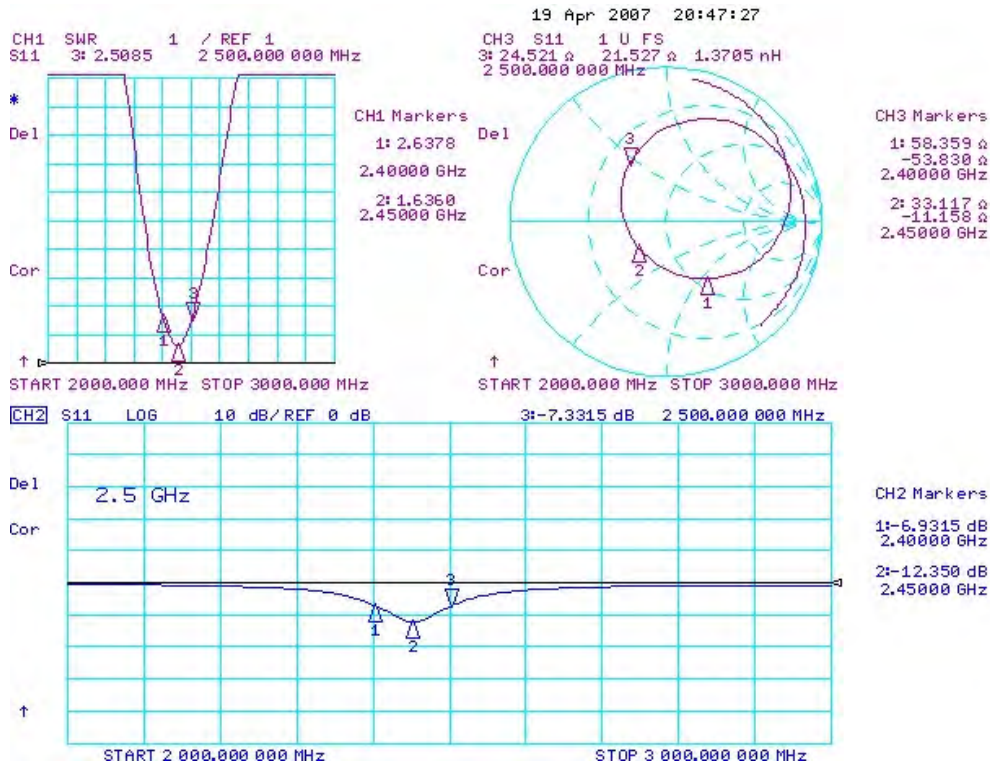

4/20/2007

四、 WY Antenna With PCB Shielding

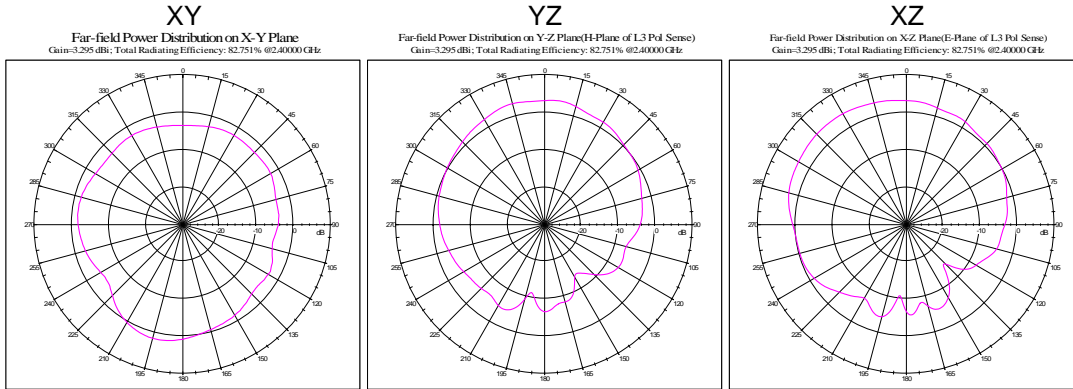

2.4GHz Gain = 3.29498 dBi Efficiency = 82.751%

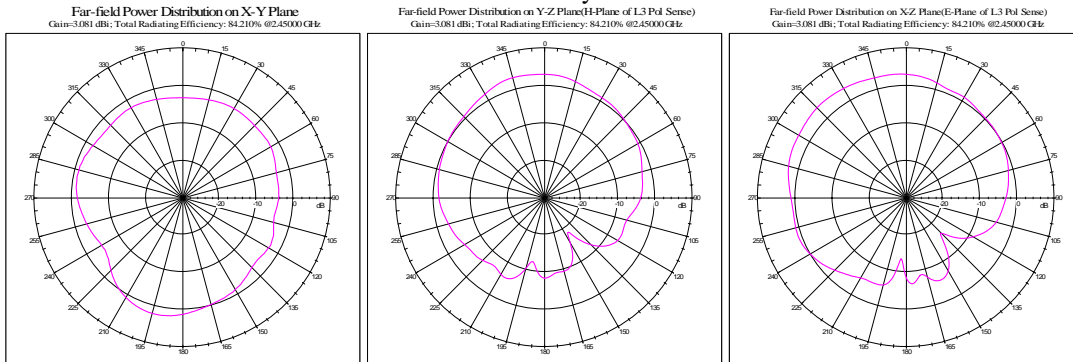

2.45GHz Gain = 3.08085 dBi Efficiency = 84.210%

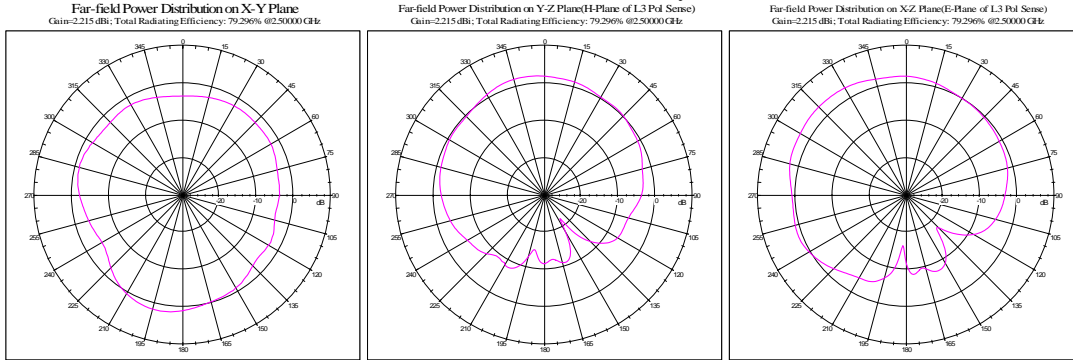

2.5GHz Gain = 2.21468 dBi Efficiency = 79.296%

Date : 2005/02/02

Our Spec. No. WS05-M016

MESSRS.

SPECIFICATION
FOR
HIGH FREQUENCY COAXIAL CABLE
" KHCX - 32AWG - SB - TA " GRAY

SHOWA ELECTRIC WIRE & CABLE CO., LTD.

TORANOMON

TOKYO JAPAN

T. Mori

T. Mori
Manager, Engineering Section
Engineering Dept.
Electronic Wire Business Unit

1. 適用(SCOPE)

本仕様書は電子機器などの内部配線に使用される細径同軸“KHCX-32AWG-SB-TA”の構造と特性について定める。

This specification covers the construction and characteristics of coaxial cable “KHCX-32AWG-SB-TA” for internal wiring of electronic equipment.

2. ケーブル型名の説明 (EXPLANATION OF CABLE TYPE)

KHCX-32AWG-SB-TA

(1) (2) (3) (4)

(1) ケーブル略称 (Cable Abbreviation)

(2) 導体サイズ (Conductor Size)

(3) Inner Conductor Type (4) Outer Conductor Type.

3. 構造(CONSTRUCTION)

項目 Item		要求特性 Requirement
内部導体 Inner conductor	材質 Material	銀めっき軟銅線 Silver coated annealed copper wire
	構成 Stranding	7/0.08mm
	外径 Diameter	標準 0.24mm Nom. 0.24mm
絶縁体 Insulation	材質 Material	FEP
	色別 Color	自然色 Natural
	厚さ Thickness	標準 0.22mm Nom. 0.22mm
	外径 Diameter	0.68 +0.04/ -0.02mm
外部導体 Outer conductor	材質 Material	錫めっき銅合金線編組 Tinned copper alloy wire braid shield
	構成 Stranding	16/4/0.05 mm
	編組密度 Coverage	Approx. 90%
シース Sheath	材質 Material	FEP
	色別 Color	灰・白・黒 Gray・White・Black
	厚さ Thickness	標準 0.10mm Nom. 0.10mm
仕上外径 Overall diameter		1.13mm +0.08/ -0.05mm
概算質量 Approximate mass		3 kg/km

4. 特性 (CHARACTERISTICS)

項目 Item	単位 Unit	要求特性 Requirements
導体抵抗 Conductor Resistance	Ω/km	597 以下 (20°C) Max. 520 (at 20°C)
絶縁抵抗 Insulation Resistance	$\text{M}\Omega\text{km}$	1,500 以上 (DC 500V 1 分間充電後, 20°C) Min. 1,500 (After charge DC 500V for 1 min. at 20°C)
耐電圧 Dielectric Strength	-	絶縁体 : AC.1.5kV/0.15 秒間 (スパークテスト) Dielectric core : No breakdown at AC.1.5kV for 0.15sec by spark test.
		シース : AC.1.5kV/0.15 秒間 (スパークテスト) Jacket : No breakdown at AC.1.5kV for 0.15sec by spark test.
		内部導体-外部導体間 : AC.500V/1 分間 No breakdown at AC.500V for 1 min between outer conductor and inner conductor.
静電容量 Capacitance	pF/m	標準 98 (at 1kHz) Nom. 98 (at 1kHz)
特性インピーダンス Characteristic Impedance	Ω	50 ± 2 (at TDR)
減衰量 Attenuation	dB/m	2.0GHz : 2.9 以下 Max.2.9
		2.4GHz : 3.2 以下 Max.3.2
		3.0GHz : 3.7 以下 Max.3.7
		4.0GHz : 4.3 以下 Max.4.3
		5.0GHz : 4.8 以下 Max.4.8
		6.0GHz : 5.3 以下 Max.5.3
VSWR	--	2.4~2.5GHz : 1.20 以下 Max.1.20
		4.8~6.0GHz : 1.40 以下 Max.1.40
耐はんだ性 Heat resistance for solder	--	絶縁体およびシースの寸法変化は 0.2mm 以下のこと。 Shrink and expansion of dielectric core or jacket should not be more than 0.2mm. 試験条件(test condition) : 255°C \pm 5°C * 3 sec.



図 1 .ケーブル構造図

Fig.1. Cable Cross-Section

SGS Test Report

Product : RF Cable

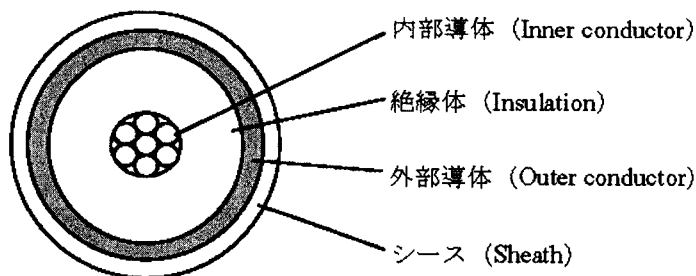
Contents

No	Description		Report No.	Page
1	Cable	1.13mm Cable ; Gray	CE/2006/B3245 CE/2006/B3239A~C	P.10~21
2	PIFA	Copper	CE/2007/11769	P.22~24
3	Sponge	EVA	GZ0603035536/CHEM	P.25~26
4	Adhesive tape	Adhesive	CE/2006/40024	P.27~30

Result for RoHS : PASS

Test Report

No : CE/2006/B3245 Date : 2006/11/21 Page: 1 of 3

SWCC SHOWA DEVICE TECHNOLOGY CO., LTD.
NO. 1-8, TORANOMON 1-CHOME, MINATO-KU, TOKYO
105-8444



Report on the submitted sample said to be ANTENNA COAXIAL CABLE UL-STYLE 11032.

Style/Item No : FOR KHCX-32AWG-SB-TA / KHCX-32AWG-WSB-TA /
KHCX-30AWG-SB-TA KHCX-36AWG-SB-TA GRAY
Sample Receiving Date : 2006/11/14
Testing Period : 2006/11/14 TO 2006/11/21

=====
Test Requested : In accordance with the RoHS Directive 2002/95/EC, and its amendment directives.

Test Method :
(1) With reference to BS EN 1122:2001, Method B for Cadmium Content. Analysis was performed by ICP-AES.
(2) With reference to US EPA Method 3050B for Lead Content. Analysis was performed by ICP-AES.
(3) With reference to US EPA Method 3052 for Mercury Content. Analysis was performed by ICP-AES.
(4) With reference to US EPA Method 3060A & 7196A for Hexavalent Chromium. Analysis was performed by UV/Vis Spectrometry.
(5) With reference to US EPA 3540C for PBB/PBDE Content. Analysis was performed by GC/MS and screening via US EPA 3550C with HPLC/DAD/MS.

Test Result(s) : Please refer to next page(s).

Daniel Yeh, M.R. / Operation Manager
Signed for and on behalf of
SGS TAIWAN LTD.

Test Report

No : CE/2006/B3245 Date : 2006/11/21 Page: 2 of 3

SWCC SHOWA DEVICE TECHNOLOGY CO., LTD.
NO. 1-8, TORANOMON 1-CHOME, MINATO-KU, TOKYO
105-8444



Test results by chemical method (Unit: mg/kg)

Test Item (s):	Method (Refer to)	Result	MDL
		No.1	
Cadmium (Cd)	(1)	n.d.	2
Lead (Pb)	(2)	n.d.	2
Mercury (Hg)	(3)	n.d.	2
Hexavalent Chromium (CrVI)	(4)	n.d.	2
Sum of PBBs	(5)	n.d.	-
Monobromobiphenyl		n.d.	5
Dibromobiphenyl		n.d.	5
Tribromobiphenyl		n.d.	5
Tetrabromobiphenyl		n.d.	5
Pentabromobiphenyl		n.d.	5
Hexabromobiphenyl		n.d.	5
Heptabromobiphenyl		n.d.	5
Octabromobiphenyl		n.d.	5
Nonabromobiphenyl		n.d.	5
Decabromobiphenyl		n.d.	5
Sum of PBDEs (Mono to Nona) (Note 4)		n.d.	-
Monobromobiphenyl ether		n.d.	5
Dibromobiphenyl ether		n.d.	5
Tribromobiphenyl ether		n.d.	5
Tetrabromobiphenyl ether		n.d.	5
Pentabromobiphenyl ether		n.d.	5
Hexabromobiphenyl ether		n.d.	5
Heptabromobiphenyl ether		n.d.	5
Octabromobiphenyl ether		n.d.	5
Nonabromobiphenyl ether		n.d.	5
Decabromobiphenyl ether		n.d.	5
Sum of PBDEs (Mono to Deca)		n.d.	-

Test Part Description:

NO.1 : GRAY PLASTIC JACKET

Note : 1. mg/kg = ppm

2. n.d. = Not Detected

3. MDL = Method Detection Limit

4. Sum of Mono to NonaBDE & according to 2005/717/EC DecaBDE is exempt.

5. "-" = Not Regulated

Test Report

No : CE/2006/B3245 Date : 2006/11/21 Page: 3 of 3

SWCC SHOWA DEVICE TECHNOLOGY CO., LTD.
NO. 1-8, TORANOMON 1-CHOME, MINATO-KU, TOKYO
105-8444



** End of Report **

Test Report

No : CE/2006/B3239A Date : 2006/11/28 Page: 1 of 3

SWCC SHOWA DEVICE TECHNOLOGY CO., LTD.
NO. 1-8, TORANOMON 1-CHOME, MINATO-KU, TOKYO
105-8444



Report on the submitted sample said to be ANTENNA COAXIAL CABLE UL-STYLE 11032.

Style/Item No : KHCX-32AWG-SB-TA KHCX-32AWG-WSB-TA
KHCX-30AWG-SB-TA KHCX-36AWG-SB-TA
Sample Receiving Date : 2006/11/14
Testing Period : 2006/11/14 TO 2006/11/21

=====
Test Requested : In accordance with the RoHS Directive 2002/95/EC, and its amendment directives.

Test Method :
(1) With reference to BS EN 1122:2001, Method B for Cadmium Content. Analysis was performed by ICP-AES.
(2) With reference to US EPA Method 3050B for Lead Content. Analysis was performed by ICP-AES.
(3) With reference to US EPA Method 3052 for Mercury Content. Analysis was performed by ICP-AES.
(4) With reference to US EPA Method 3060A & 7196A for Hexavalent Chromium. Analysis was performed by UV/Vis Spectrometry.
(5) With reference to US EPA 3540C for PBB/PBDE Content. Analysis was performed by GC/MS and screening via US EPA 3550C with HPLC/DAD/MS.

Test Result(s) : Please refer to next page(s).

Daniel Yeh, M.R. / Operation Manager
Signed for and on behalf of
SGS TAIWAN LTD.

Test Report

No : CE/2006/B3239A Date : 2006/11/28 Page: 2 of 3

SWCC SHOWA DEVICE TECHNOLOGY CO., LTD.
NO. 1-8, TORANOMON 1-CHOME, MINATO-KU, TOKYO
105-8444



Test results by chemical method (Unit: mg/kg)

Test Item (s):	Method (Refer to)	Result	MDL
		No.1	
Cadmium (Cd)	(1)	n.d.	2
Lead (Pb)	(2)	n.d.	2
Mercury (Hg)	(3)	n.d.	2
Hexavalent Chromium (CrVI)	(4)	n.d.	2
Sum of PBBs	(5)	n.d.	-
Monobromobiphenyl		n.d.	5
Dibromobiphenyl		n.d.	5
Tribromobiphenyl		n.d.	5
Tetrabromobiphenyl		n.d.	5
Pentabromobiphenyl		n.d.	5
Hexabromobiphenyl		n.d.	5
Heptabromobiphenyl		n.d.	5
Octabromobiphenyl		n.d.	5
Nonabromobiphenyl		n.d.	5
Decabromobiphenyl		n.d.	5
Sum of PBDEs (Mono to Nona) (Note 4)		n.d.	-
Monobromobiphenyl ether		n.d.	5
Dibromobiphenyl ether		n.d.	5
Tribromobiphenyl ether		n.d.	5
Tetrabromobiphenyl ether		n.d.	5
Pentabromobiphenyl ether		n.d.	5
Hexabromobiphenyl ether		n.d.	5
Heptabromobiphenyl ether		n.d.	5
Octabromobiphenyl ether		n.d.	5
Nonabromobiphenyl ether		n.d.	5
Decabromobiphenyl ether		n.d.	5
Sum of PBDEs (Mono to Deca)		n.d.	-

Test Part Description:

NO.1 : TRANSPARENT PLASTIC

- Note :
1. mg/kg = ppm
 2. n.d. = Not Detected
 3. MDL = Method Detection Limit
 4. Sum of Mono to NonaBDE & according to 2005/717/EC DecaBDE is exempt.
 5. "-" = Not Regulated

Test Report

No : CE/2006/B3239A Date : 2006/11/28 Page: 3 of 3

SWCC SHOWA DEVICE TECHNOLOGY CO., LTD.
NO. 1-8, TORANOMON 1-CHOME, MINATO-KU, TOKYO
105-8444



** End of Report **

Test Report

No : CE/2006/B3239B Date : 2006/11/28 Page: 1 of 3

SWCC SHOWA DEVICE TECHNOLOGY CO., LTD.
NO. 1-8, TORANOMON 1-CHOME, MINATO-KU, TOKYO
105-8444



Report on the submitted sample said to be ANTENNA COAXIAL CABLE UL-STYLE 11032.

Style/Item No : KHCX-32AWG-SB-TA KHCX-32AWG-WSB-TA
KHCX-30AWG-SB-TA KHCX-36AWG-SB-TA
Sample Receiving Date : 2006/11/14
Testing Period : 2006/11/14 TO 2006/11/21

=====
Test Requested : In accordance with the RoHS Directive 2002/95/EC, and its amendment directives.

Test Method :
(1) With reference to BS EN 1122:2001, Method B for Cadmium Content. Analysis was performed by ICP-AES.
(2) With reference to US EPA Method 3050B for Lead Content. Analysis was performed by ICP-AES.
(3) With reference to US EPA Method 3052 for Mercury Content. Analysis was performed by ICP-AES.
(4) With reference to US EPA Method 3060A & 7196A for Hexavalent Chromium. Analysis was performed by UV/Vis Spectrometry.

Test Result(s) : Please refer to next page(s).

Daniel Yeh, M.R. / Operation Manager
Signed for and on behalf of
SGS TAIWAN LTD.

Test Report

No : CE/2006/B3239B Date : 2006/11/28 Page: 2 of 3

SWCC SHOWA DEVICE TECHNOLOGY CO., LTD.
 NO. 1-8, TORANOMON 1-CHOME, MINATO-KU, TOKYO
 105-8444



Test results by chemical method (Unit: mg/kg)

Test Item (s):	Method (Refer to)	Result	MDL
		No.1	
Cadmium (Cd)	(1)	n.d.	2
Lead (Pb)	(2)	n.d.	2
Mercury (Hg)	(3)	n.d.	2
Hexavalent Chromium (CrVI)	(4)	n.d.	2

Test Part Description:

NO.1 : SILVER COLORED METAL WIRE

- Note :
- 1. mg/kg = ppm
 - 2. n.d. = Not Detected
 - 3. MDL = Method Detection Limit

Test Report

No : CE/2006/B3239B Date : 2006/11/28 Page: 3 of 3

SWCC SHOWA DEVICE TECHNOLOGY CO., LTD.
NO. 1-8, TORANOMON 1-CHOME, MINATO-KU, TOKYO
105-8444



** End of Report **

Test Report

No : CE/2006/B3239C Date : 2006/11/28 Page: 1 of 3

SWCC SHOWA DEVICE TECHNOLOGY CO., LTD.
NO. 1-8, TORANOMON 1-CHOME, MINATO-KU, TOKYO
105-8444



Report on the submitted sample said to be ANTENNA COAXIAL CABLE UL-STYLE 11032.

Style/Item No : KHCX-32AWG-SB-TA KHCX-32AWG-WSB-TA
KHCX-30AWG-SB-TA KHCX-36AWG-SB-TA
Sample Receiving Date : 2006/11/14
Testing Period : 2006/11/14 TO 2006/11/21

=====
Test Requested : In accordance with the RoHS Directive 2002/95/EC, and its amendment directives.

Test Method :
(1) With reference to BS EN 1122:2001, Method B for Cadmium Content. Analysis was performed by ICP-AES.
(2) With reference to US EPA Method 3050B for Lead Content. Analysis was performed by ICP-AES.
(3) With reference to US EPA Method 3052 for Mercury Content. Analysis was performed by ICP-AES.
(4) With reference to US EPA Method 3060A & 7196A for Hexavalent Chromium. Analysis was performed by UV/Vis Spectrometry.

Test Result(s) : Please refer to next page(s).

Daniel Yeh, M.R. / Operation Manager
Signed for and on behalf of
SGS TAIWAN LTD.

Test Report

No : CE/2006/B3239C Date : 2006/11/28 Page: 2 of 3

SWCC SHOWA DEVICE TECHNOLOGY CO., LTD.
 NO. 1-8, TORANOMON 1-CHOME, MINATO-KU, TOKYO
 105-8444



Test results by chemical method (Unit: mg/kg)

Test Item (s):	Method (Refer to)	Result	MDL
		No.1	
Cadmium (Cd)	(1)	n.d.	2
Lead (Pb)	(2)	n.d.	2
Mercury (Hg)	(3)	n.d.	2
Hexavalent Chromium (CrVI)	(4)	n.d.	2

Test Part Description:

NO.1 : SILVER COLORED METAL FOIL

- Note :
1. mg/kg = ppm
 2. n.d. = Not Detected
 3. MDL = Method Detection Limit

Test Report

No : CE/2006/B3239C Date : 2006/11/28 Page: 3 of 3

SWCC SHOWA DEVICE TECHNOLOGY CO., LTD.
NO. 1-8, TORANOMON 1-CHOME, MINATO-KU, TOKYO
105-8444



** End of Report **

測試報告

號碼：CE/2007/11769

日期：2007/01/15

頁數：1 of 3

青棋五金有限公司



PRO BRASS METAL CO., LTD.

以下測試樣品係由客戶送樣，且由客戶聲稱並經客戶確認如下(The following sample(s) was/were submitted and identified by/on behalf of the client as)：

樣品名稱：洋白板
Sample Description：NICKEL SILVER
樣品型號(Style/Item No.)：C7701
收件日期(Sample Receiving Date)：2007/1/8
測試期間(Testing Period)：2007/1/8 TO 2007/01/15

=====
測試需求 / Test Requested：參照 RoHS 2002/95/EC 及其修定指令要求。 / In accordance with the RoHS Directive 2002/95/EC, and its amendment directives.

測試方法 / Test Method：參考 IEC 62321, Ed. 1 111/54/CDV 方法檢測。 / With reference to IEC 62321, Ed.1 111/54/CDV. Procedures for the Determination of Levels of Regulated Substances in Electrotechnical Products.

- (1) 用感應耦合電漿原子發射光譜儀檢測鎘含量 / Determination of Cadmium by ICP-AES.
- (2) 用感應耦合電漿原子發射光譜儀檢測鉛含量 / Determination of Lead by ICP-AES
- (3) 用感應耦合電漿原子發射光譜儀檢測汞含量。 / Determination of Mercury by ICP-AES
- (4) 針對金屬材質之樣品，用 Spot test / Colorimetric 方法檢測六價鉻含量。 / Determination of Hexavalent Chromium for metallic samples by Spot test / Colorimetric Method.

測試結果 / Test Result(s)：請見下一頁。

Daniel Yeh, M.R. / Operation Manager
Signed for and on behalf of
SGS TAIWAN LTD.

測試報告

號碼：CE/2007/11769

日期：2007/01/15

頁數：2 of 3

青棋五金有限公司



PRO BRASS METAL CO., LTD.

測試結果 (單位: mg/kg) / Test Result(s)

測試項目 / Test Item (s):	測試方法 Method (Refer to)	結果 / Result	方法偵測 極限值 (MDL)
		No.1	
鎘 / Cadmium (Cd)	(1)	n.d.	2
鉛 / Lead (Pb)	(2)	22.8	2
汞 / Mercury (Hg)	(3)	n.d.	2
六價鉻 / Hexavalent Chromium Cr(VI) by Spot test / boiling water	(4)	Negative	See Note 4

測試部位描述 / TEST PART DESCRIPTION:

NO.1 : 銀色金屬 / SILVER COLORED METAL

Note: 1. mg/kg = ppm

2. n.d. = Not Detected / 未檢出

3. MDL = Method Detection Limit / 方法偵測極限值

4. Spot-test:

Negative = Absence of CrVI coating / surface layer,

Positive = Presence of CrVI coating / surface layer;

(The tested sample should be further verified by boiling-water-extraction method if the spot test result cannot be confirmed.)

Negative=鍍層中偵測不到六價鉻, Positive= 鍍層中偵測到六價鉻;

當該測項無法確認時, 測試樣品可藉由boiling-water-extraction測試方法進一步確認

Boiling-water-extraction:

Negative = Absence of CrVI coating / surface layer,

Positive = Presence of CrVI coating / surface layer; the detected concentration in boiling-water-extraction solution is equal or greater than 0.02 mg/kg with 50 cm² sample surface area.

Negative=鍍層中偵測不到六價鉻, Positive=鍍層中偵測到六價鉻;

該濃度溶液 ≥ 0.02 mg/kg with 50 cm² (sample surface area)

測試報告

號碼：CE/2007/11769

日期：2007/01/15

頁數：3 of 3

青棋五金有限公司



PRO BRASS METAL CO., LTD.



** 報告結尾 **



Test Report

No.: GZ0603035536/CHEM

Date: MAR 28, 2006

Page 1 of 2

DONG GUAN TAI FENG PACKING MATERIAL
XI TAI LONG, SHA TIAN, DONG GUAN CITY, GUANGDONG

Report on the submitted sample said to be EVA

SGS Ref No. : GZ060306977EC-2.1
Sample Receiving Date : MAR 21, 2006
Testing Period : MAR 21, 2006 TO MAR 28, 2006

Test Requested : (1) As specified by client, to determine the Lead, Cadmium, Mercury & Hexavalent Chromium content in the submitted sample.
(2) Determination of PBBs (Polybrominated Biphenyls), PBDEs (Polybrominated Diphenylethers) of the submitted sample.

Test Method : (1) Lead content - With reference to EPA method 3050B: 1996 / other acid digestion.
Cadmium content - With reference to BS EN1122: 2001 method B / other acid digestion.
Mercury content - With reference to EPA 3052: 1996 / 7473: 1998 / other acid digestion.
Hexavalent Chromium content - With reference to EPA 3060A : 1996 & EPA 7196A : 1992.
Analysis was performed by Atomic Absorption Spectrometer / Inductively Coupled Plasma Atomic Emission Spectrometer (ICP-AES) / Direct Mercury analyzer / UV-VIS Spectrophotometer.
(2) With reference to EPA 3540C / 3550C. Analysis was performed by GC/MS.

Results : Please refer to next page.

Signed for and on behalf of
SGS-CSTC Ltd.

Zhang Li, Amy
Sr. Engineer

This Test Report is issued by the Company subject to its General Conditions of Service printed overleaf or attached. Said Conditions are also available upon request or are accessible at www.sgs.com. Attention is drawn to the limitations of liability, indemnification and jurisdictional policies defined therein. The results shown in this Test Report refer only to the sample(s) tested unless otherwise stated and such sample(s) are retained for 90 days only. This Test Report shall not be reproduced except in full, without written approval of the Company.

SGS-CSTC Standards Technical Services Co., Ltd.
Guangzhou Environmental Chemical Laboratory.

198 KEZHU Road, SCIENTECH Park Guangzhou Economic & Technology Development District, Guangzhou, China 510663 t (86-20)82155555 f (86-20)82076113 www.cn.sgs.com
中国·广州·经济技术开发区科学城科珠路198号 邮编: 510663 t (86-20)82155565 f (86-20)82075113 e sgs.china@sgs.com

GZCM 527365

Member of SGS Group (Société Générale de Surveillance)

Test Report

No.: GZ0603035536/CHEM

Date: MAR 28, 2006

Page 2 of 2

Results :

(1)

Item	Unit	MDL	Black sheet
Lead Content (Pb)	ppm	2	23
Cadmium Content (Cd)	ppm	2	N.D.
Mercury Content (Hg)	ppm	2	N.D.
Hexavalent Chromium Content [Cr(VI)]	ppm	2	N.D.

Note : - N.D. = Not Detected (< MDL)
 - MDL = Method Detection Limit
 - ppm = mg/kg

(2)

	Black sheet
Flame Retardants	
Polybrominated Biphenyls (PBBs)	
Monobromobiphenyl	N.D.
Dibromobiphenyl	N.D.
Tribromobiphenyl	N.D.
Tetrabromobiphenyl	N.D.
Pentabromobiphenyl	N.D.
Hexabromobiphenyl	N.D.
Heptabromobiphenyl	N.D.
Octabromobiphenyl	N.D.
Nonabromodiphenyl	N.D.
Decabromodiphenyl	N.D.
Polybrominated Diphenylethers (PBDEs)	
Monobromodiphenyl ether	N.D.
Dibromodiphenyl ether	N.D.
Tribromodiphenyl ether	N.D.
Tetrabromodiphenyl ether	N.D.
Pentabromodiphenyl ether	N.D.
Hexabromodiphenyl ether	N.D.
Heptabromodiphenyl ether	N.D.
Octabromodiphenyl ether	N.D.
Nonabromodiphenyl ether	N.D.
Decabromodiphenyl ether	N.D.

Note : - N.D. = Not Detected (< 5 ppm)
 - ppm = mg/kg

*** End of Report ***

This Test Report is issued by the Company subject to its General Conditions of Service printed overleaf or attached. Said Conditions are also available upon request or are accessible at www.sgs.com. Attention is drawn to the limitations of liability, indemnification and jurisdictional policies defined therein. The results shown in this Test Report refer only to the sample(s) tested unless otherwise stated and such sample(s) are retained for 90 days only. This Test Report shall not be reproduced except in full, without written approval of the Company.



198 KEZHU Road, SCIENTECH Park Guangzhou Economic & Technology Development District, Guangzhou, China 510663
 中国·广州·经济技术开发区科学城科珠路198号 邮编:510663

(86-20)82155555 (86-20)82075113 www.cn.sgs.com
 (86-20)82155555 (86-20)82075113 sgs.china@sgs.com

GZCM 527364

Member of SGS Group (Société Générale de Surveillance)

Test Report

3M TAIWAN LTD.
66, 800 LANE, CHUNG-SHAN SOUTH ROAD, YANG-MEI,
TAOYUAN, TAIWAN, R. O. C.

Report No. : CE/2006/40024
Date : 2006/04/10
Page : 1 of 4

The following merchandise was (were) submitted and identified by the client as :

Type of Product : DOUBLE COATED HIGH SOFT ACRYLIC FOAM TAPE,
Y-4604, Y-4608, Y-4612, Y-4620
Style/Item No : Y-4604, Y-4608, Y-4612, Y-4620
Sample Received : 2006/03/31
Testing Date : 2006/03/31 TO 2006/04/10

=====
Test Result : - Please see the next page -

Daniel Yeh, M.R. / Operation Manager
Signed for and on behalf of
SGS TAIWAN LTD.

Test Report

3M TAIWAN LTD.
66, 800 LANE, CHUNG-SHAN SOUTH ROAD, YANG-MEI,
TAOYUAN, TAIWAN, R. O. C.

Report No. : CE/2006/40024
Date : 2006/04/10
Page : 2 of 4

Test Result

PART NAME NO.1 : GRAY DOUBLE ADHESIVE FOAM TAPE

Test Item (s):	Unit	Method	MDL	Result	Spec.
				No. 1	
Monobromobiphenyl	%	With reference to USEPA3540C or USEPA3550C. Analysis was performed by HPLC/DAD, LC/MS or GC/MS. (prohibited by 2002/95/EC (RoHS), 83/264/EEC, and 76/769/EEC)	0.0005	N.D.	-
Dibromobiphenyl	%		0.0005	N.D.	-
Tribromobiphenyl	%		0.0005	N.D.	-
Tetrabromobiphenyl	%		0.0005	N.D.	-
Pentabromobiphenyl	%		0.0005	N.D.	-
Hexabromobiphenyl	%		0.0005	N.D.	-
Heptabromobiphenyl	%		0.0005	N.D.	-
Octabromobiphenyl	%		0.0005	N.D.	-
Nonabromobiphenyl	%		0.0005	N.D.	-
Decabromobiphenyl	%		0.0005	N.D.	-
Total PBBs (Polybrominated biphenyls)/Sum of above	%		-	N.D.	-
Monobromobiphenyl ether	%	With reference to USEPA3540C or USEPA3550C. Analysis was performed by HPLC/DAD, LC/MS or GC/MS. (prohibited by 2002/95/EC (RoHS), 83/264/EEC, and 76/769/EEC)	0.0005	N.D.	-
Dibromobiphenyl ether	%		0.0005	N.D.	-
Tribromobiphenyl ether	%		0.0005	N.D.	-
Tetrabromobiphenyl ether	%		0.0005	N.D.	-
Pentabromobiphenyl ether	%		0.0005	N.D.	-
Hexabromobiphenyl ether	%		0.0005	N.D.	-
Heptabromobiphenyl ether	%		0.0005	N.D.	-
Octabromobiphenyl ether	%		0.0005	N.D.	-
Nonabromobiphenyl ether	%		0.0005	N.D.	-
Decabromobiphenyl ether	%		0.0005	N.D.	-
Total PBBEs(PBDEs) (Polybrominated biphenyl ethers)/Sum of above	%		-	N.D.	-
Total of Mono to Nona-brominated biphenyl ether. (Note 4)	%	-	N.D.	-	

Test Report

3M TAIWAN LTD.
66, 800 LANE, CHUNG-SHAN SOUTH ROAD, YANG-MEI,
TAOYUAN, TAIWAN, R. O. C.

Report No. : CE/2006/40024
Date : 2006/04/10
Page : 3 of 4

PASS

Test Item (s):	Unit	Method	MDL	Result	Spec.
				No.1	
94/62/EC (Heavy metal content)					
Chromium VI (Cr+6)	ppm	UV-VIS(US EPA 7196A) after reference to US EPA 3060A.	2	N.D.	-
Cadmium (Cd)	ppm	ICP-AES after as per EN 1122, method B:2001 or other acid digestion.	2	N.D.	-
Lead (Pb)	ppm	ICP-AES after as per US EPA 3050B or other acid digestion.	2	N.D.	-
Mercury (Hg)	ppm	ICP-AES after as per US EPA 3052 or other acid digestion.	2	N.D.	-
Total Lead+Cadmium+Mercury+Chromium VI	ppm	Total Lead+Cadmium+Mercury+Chromium VI (94/62/EC)	-	N.D.	100

- NOTE: (1) N.D. = Not detected (<MDL)
 (2) ppm = mg/kg
 (3) MDL = Method Detection Limit
 (4) Decabromobiphenyl ether (DecaBDE) in polymeric applications is Commission Decision of 13 Oct 2005 amending Directive under document 2005/717/EC.
 (5) PBBEs=PBDEs=Polybrominated Diphenyl Ethers=PBDOs=PBBOs.
 (6) " - " = Not Regulation

Test Report

3M TAIWAN LTD.
66, 800 LANE, CHUNG-SHAN SOUTH ROAD, YANG-MEI,
TAOYUAN, TAIWAN, R. O. C.

Report No. : CE/2006/40024
Date : 2006/04/10
Page : 4 of 4





RoHS 排外條款說明
RoHS Exclusive item Hazardous Substance

本公司保證，本產品均屬環保產品，皆符合 RoHS 法規要求，並適用於 RoHS 規定之排除條款。

We hereby confirm and assure that all parts and sub-materials delivered to your company comply with RoHS Standard and apply to RoHS Exclusive item.

RoHS 合金類排除條款要求如下：

RoHS Exclusive item :

合金種類 alloys item	鉛允許含量(ppm) Lead acceptance concentration
鋼材 steel	<3,500ppm
鋁合金 aluminium alloys	<4,000ppm
銅合金 copper alloys	<40,000ppm
焊錫 solder	<1,000ppm

立承諾書人

公司名稱：華裕實業股份有限公司
company name: WHA YU INDUSTRIAL CO., LTD

公司地址：新竹市公道五路二段 326 號
company address: No.326. Sec 2. Kung Tao 5 Road. Hsin Chu City, Taiwan

聯絡電話：03-5714225
TEL: +886-3-5714225

負責人：_____ 林祺生 _____ 董事長
sign by

立約日期：西元 2006 年 9 月 05 日
Date: 2006. 09. 05



歐盟議會和歐盟理事會 2003 年 1 月 23 日第 2002/95/EC 號 關於在電氣電子設備中限制使用某些有害物質指令

(外經貿部科技司翻譯，僅供參考)

歐洲議會和歐盟理事會，

注意到成立歐洲共同體的條約，特別是其中第 95 條，

注意到歐盟委員會的建議，

注意到歐盟經濟與社會委員會的意見，

注意到歐盟地區委員會的意見，

按照歐洲共同體條約第 251 條所規制的程式列事並根據協調委員會於 2002 年 11 月 8 日通過的聯合文本，

鑒於：

(1) 各成員國為限制在電子電氣設備中使用有害物質而制訂的法規或行政措施之間存在的差異能產生貿易壁壘和扭曲共同體內的競爭，甚至對單一市場的建立及其功能產生直接影響。因此有必要協調成員國在此領域的法規，以利於保護人類健康和報廢電子電氣設備合乎環境要求的回收和處理。

(2) 歐盟理事會於 2000 年 12 月 7~9 日在尼斯召開的會議上批准了部長理事會于 2000 年 12 月 4 日就預防原則通過的決定。

(3) 歐盟委員會 1996 年 7 月 30 日回顧共同體廢棄物管理戰略的通訊強調了減少廢物中有害物質含量的必要並指出制定在產品和加工過程中限制使用這些有害物質的歐共體法規的潛在益處。

(4) 理事會 1988 年 1 月 25 日為消除鎘 環境污染的歐共體行動計畫的決定要求歐盟委員會刻不容緩地發展該計畫中的特殊措施。人類健康也必須得到保護，因此應實施一個特別限制鎘的使用及加快研究其替代品的整體戰略。決定強調在不存在適當的和更安全的選擇的情況下應限制鎘的使用。

(5) 證據表明，歐盟理事會和歐洲議會 2003 年 1 月 27 日關於報廢電子電氣設備的第 2002/96/EC 號指令規定的報廢電子電氣設備的收集、處理、回收和處置措施對於減少與涉及的重金屬和阻燃劑相關的廢物管理問題很必要。然而，儘管有那些措施，但在目前的廢物處理中仍將繼續發現報廢電子電氣設備的實質部分。即使報廢電子電氣設備被分類收集並遵守回收程式，但汞、鎘、鉛、六價鉻、聚溴聯苯 (PBB)、聚溴二苯醚 (PBDE) 的成分仍有可能對人類健康和環境形成危險。

(6) 考慮到技術和經濟的可行性，確保顯著減少這些物質對健康和環境形成的危險的最有效的、且在共同體內可實現所選擇保護水平的方式是在電子電氣設備中以安全或更安全的物質替代它們。限制這些有害物質的使用也就是提高報廢電子電氣設備回收的可能性和經濟利益並減少它們對回收工廠工人健康所造成的負面影響。

(7) 要科學研究與評估本指令管轄的物質，它們已在歐共體和成員國層面受到不同措施的管理。

(8) 本指令規定的措施考慮了現有的國際準則和建議並基於對可獲得的科學和技術資訊的評估。由於缺乏措施可能在共同體內產生危險，所以這些措施對實現所選擇的對人類和動物健康及環境的保護水平是必要的。應及時檢查這些措施，必要時，考慮了獲得的科技資訊後可進行調整。

(9) 本指令的實施不影響共同體在安全和衛生要求方面的立法以及共同體關於廢物管理的特殊立法，特別是1991年3月18日理事會關於含有某些危險物質的電池和蓄電池的第91/157/EEC號指令。

(10) 應考慮不含有重金屬、聚溴二苯醚 (PBDE) 和聚溴聯苯 (PBB) 的電子電氣設備的技術發展。一旦獲得了科學證據和考慮了預防原則，應檢查是否可禁止其他有害物質的使用並以更加合乎環境要求的、確保對消費者的保護不低於相同水平的替代品來替代它們。

(11) 如果從科技角度來看，不可能有替代品，或者替代品對環境和健康所造成的負面影響大於其對環境和健康帶來的益處，那麼可免除執行替代品的要求。開發電子電氣設備中有害物質替代品的工作仍要繼續進行，以使它們符合電子電氣設備使用者的健康與安全需要。

(12) 因為產品的再利用、翻新和延長使用期是有益的，所以需要提供必要的零件。

(13) 與逐步停止使用和禁止使用有害物質的要求免除相關的科技進步的修改應由歐盟委員會按照委員會程式實現。

(14) 實施本指令所必要的措施應根據理事會1999年6月28日的1999/468/EC號決議規定的、實施授權給歐委會的權力的程式來採納。

茲通過本指令：

第1條

目標

本指令的目標是使各成員國關於在電子電氣設備中限制使用有害物質的法律趨於一致，有助於保護人類健康和報廢電子電氣設備合乎環境要求的回收和處理。

第2條

範圍

1· 在不違反第6條的情況下，本指令應適用於提令第2002/96/EC號指令 (WEEE) 附錄 I A 規定的1、2、3、4、5、6、7和10類電子電氣設備，以及家用電燈泡和照明設施。

2· 本指令的實施不應違背共同體關於安全和健康要求的立法和共同體關於廢物管理的專門立法。

3· 本指令對2006年7月1日前投放市場的電子電氣設備的部件、修理部件或再利用部件不適用。

第3條

定義

就本指令而言，適用下述定義：

(a) “電子電氣設備”或“EEE”指為正常運行而依賴於電流或電磁場工作的設備和指令 2002/96/EC (WEEE) 附件 I A 中列出的能產生、傳輸和測量電流和電磁場的設備，且這些設備的設計電壓是交流電不超過 1000 伏特，直流電不超過 1500 伏特；

(b) “生產者”指任何人，他們不管所採用的銷售技術，根據歐洲議會和理事會 1997 年 5 月 20 日關於保護遠程合同中消費者的第 1997/7/EC 號指令包括程通訊：

(i) 用自己品牌生產並銷售電子電氣設備；

(ii) 以自己品牌再銷售由其他供應商提供的設備，如果再銷的設備上仍保留原生產者的品牌，這樣的再銷售者不能視作為上述 (i) 副點的生產者；或

(iii) 專業從事向成員國進口或出口電子電氣設備。

僅僅是按照某種金融協議提供資金者不能被視為“生產者”，除非他符合上述 (i) 至 (iii) 副點作為生產者行事。

第 4 條

防止

1. 成員國將確保，從 2006 年 7 月 1 日起，投放於市場的新電子和電氣設備不包含鉛，汞，鎘，六價鉻，聚溴二苯醚 (PBDE) 或聚溴聯苯 (PBB)。成員國在本指令通過前根據共同體法規制定的限制或禁止在電子電氣設備中使用這些物質的措施可以維持至 2006 年 7 月 1 日。

2. 條款 1 將不適用於附件中所列舉的應用。

3. 基於歐委會的建議，一旦可獲得科學證據，歐洲議會和理事會應根據《第六個共同體環境行動計畫》中規定的化學政策原則決定其他有害物質的禁用以及選擇確保對消費者保護水平至少相同的更加合乎環境要求的產品作為其替代品。

第 5 條

適應科學和技術進步

1. 為下列目的，旨在使附件適應科技進步的必要修改，應根據條款 7 (2) 提及的程式而進行：

(a) 必要時，可建立允許在電子電氣設備的特殊物質和部件中含有條款 4 (1) 所提及物質的最高值；

(b) 電子電氣設備的材料和元件可背離第 4 款 (1) 的規定，如果它們的去除或通過設計改變而使用替代品或使用不含有提及的材料或物質的材料或元件在科技上不現實時，或替代品對環境、健康和/或消費者安全造成的負面影響好過它們對環境、健康和/或消費者安全造成的益處時；

(c) 至少每隔四年對附件進行一次檢查，或者在將一項加入到附件後四年對附件進行檢查，加入新項的目的是考慮取消附件中的電子電氣設備材料和元件，如果它們的去除或通過設計改變而使用替代品或使用不包括第 4 (1) 款的材料或物質的材料和元件在科技上是可行時，條件是替代品對環境、健康和/或消費者安全產生的負面影響不可能大於其對環境、健康和/或消費者安排帶來的正面利益。

2. 附件在遵照條款 1 修改之前，歐盟委員會將專門與電子電器設備生產者、回收者、垃圾處理者、環保組織和雇員與消費者協會諮詢磋商。磋商結果應遞交給條款 7 (1) 提及的委員會。歐盟委員會應考慮其收到的意見。

第 6 條

檢查

在 2005 年 2 月 13 日之前，歐盟委員會應檢查本指令規定的措施以便必要時考慮新的科學證據。

特別是，歐盟委員會應在該日期之前提交將第 2002/96/EC (WEEE) 號指令附件 I A 所列的第 8 和第 9 類的設備納入本指令範圍的建議。

委員會也將根據科學事實並考慮預防原則，研究條款 4 (1) 中物質是否需要調整，適當時，可向歐洲議會和理事會提出建議。

應當特別注意檢查電子電氣設備中使用的其他有害物質和材料對環境和人類健康的影響。歐委會將檢查取代這些物質和材料的可行性，並且在適當的時候，就擴大第 4 條的範圍向歐洲議會和理事會提交建議。

第 7 條

委員會

1· 歐盟委員會將由根據第 75/442/EEC 號指令第 18 條成立的委員會協助工作。

2· 當參考本款時，應適用第 1999/468/EC 號決議第 5 條、第 7 條以及第 8 條。

第 1999/468/EC 號決議第 5 條 6 款規定的期間應被定為 3 個月。

3· 委員會將採用其程式規定。

第 8 條

懲罰

成員國應決定對違反根據本指令而制定的成員國規定的行為適當的懲罰。這些規定的懲罰應當有效，適度並有勸誡性。

第 9 條

過渡

1· 成員國應在 2004 年 8 月 13 日之前使符合本指令所必要的法律、規則和行政規定生效。並將這些立即通知歐委會。

當成員國制訂那些措施時，它們必須包括本指令的參照號或在該國官方出版物上出版時伴以此參考號。標誌此參考號的方法由成員國規定。

2· 成員國要將本指令範圍內制定的所有法律、規則和行政規定的文本通知歐委會。

第 10 條

生效

本指令自在歐洲共同體《官方公報》上公佈之日起生效。

第 11 條

收受方

本指令將簽發至各成員國。

2003 年 1 月 23 日完成於布魯塞爾

歐洲議會主席 歐盟理事會主席

P. COX G. DRYS

ANNEX

免除第 4 (1) 條中所要求的鉛、汞、鎘和六價鉻的應用

1. 小型日光燈中的汞含量不得超過 5 毫克/燈；
2. 一般用途的直管日光燈中的汞含量不得超過：
 - 鹽磷酸鹽 10 毫克
 - 正常的三磷酸鹽 5 毫克
 - 長效的三磷酸鹽 8 毫克
3. 特殊用途的直管日光燈中的汞含量；
4. 本附錄中未特別提及的其他照明燈中的汞含量；
5. 陰極射線管、電子部件和發光管的玻璃內的鉛含量；
6. 鋼中合金元素中的鉛含量達 0.35%、鋁含量達 0.4%，銅合金中的鉛含量達 4%；
7. -- 高溫融化的焊料中的鉛（即：錫鉛焊料合金中鉛含量超過 85%）；
-- 用於伺服器、記憶體和存儲系統的焊料中的鉛（豁免准予至 2010 年）；
-- 用於交換、信號和傳輸，以及電信網路管理的網路基礎設施設備中焊料中的鉛；
-- 電子陶瓷產品中的鉛（例如：高壓電子裝置）；
8. 根據修改關於限制特定危險物質和預製品銷售和使用的第 76/769/EEC 號指令的第 91/338/EEC 號指令禁止以外的鎘電鍍。
9. 在吸收式電冰箱中作為碳鋼冷卻系統防腐劑的六價鉻。
10. 根據在第 7 (2) 條中提及的程式，歐盟委員會應評價以下方面的應用：
 - 台卡二苯醚 (Deca BDE) ；
 - 特殊用途的直管日光燈中的汞；
 - 以下用途中所使用的焊料中的鉛：伺服器、記憶體、用於交換 和傳輸的網路基礎設施、電信網路管理設備（旨在設定本指令豁免部分的特定截止時間）；
 - 燈泡。

目前重點是儘快決定這些項是否進行相應的修改。

外經貿部科技司發佈歐盟電子電氣產品兩指令中文譯文

DIRECTIVE 2002/95/EC OF THE EUROPEAN PARLIAMENT AND OF THE COUNCIL
of 27 January 2003
on the restriction of the use of certain hazardous substances in electrical and electronic equipment

THE EUROPEAN PARLIAMENT AND THE COUNCIL OF THE EUROPEAN UNION,

Having regard to the Treaty establishing the European Community, and in particular Article 95 thereof,

Having regard to the proposal from the Commission ⁽¹⁾,

Having regard to the opinion of the Economic and Social Committee ⁽²⁾,

Having regard to the opinion of the Committee of Regions ⁽³⁾,

Acting in accordance with the procedure laid down in Article 251 of the Treaty in the light of the joint text approved by the Conciliation Committee on 8 November 2002 ⁽⁴⁾,

Whereas:

- (1) The disparities between the laws or administrative measures adopted by the Member States as regards the restriction of the use of hazardous substances in electrical and electronic equipment could create barriers to trade and distort competition in the Community and may thereby have a direct impact on the establishment and functioning of the internal market. **It therefore appears necessary to approximate the laws of the Member States in this field and to contribute to the protection of human health and the environmentally sound recovery and disposal of waste electrical and electronic equipment.**
- (2) The European Council at its meeting in Nice on 7, 8 and 9 December 2000 endorsed the Council Resolution of 4 December 2000 on the precautionary principle.
- (3) The Commission Communication of 30 July 1996 on the review **of the Community strategy for waste management stresses the need to reduce the content of hazardous substances in waste and points out the potential benefits of Community-wide rules limiting the presence of such substances in products and in production processes.**
- (4) The Council Resolution of 25 January 1988 on a Community action programme to combat environmental pollution by cadmium ⁽⁵⁾ invites the Commission to pursue without delay the development of specific measures for such a programme. **Human health also has**

to be protected and an overall strategy that in particular restricts the use of cadmium and stimulates research into substitutes should therefore be implemented. The Resolution stresses that the use of cadmium should be limited to cases where suitable and safer alternatives do not exist.

- (5) The available evidence indicates that measures on the collection, treatment, recycling and disposal of waste electrical and electronic equipment (WEEE) as set out in Directive **2002/96/EC of 27 January 2003 of the European Parliament and of the Council on waste electrical and electronic equipment ⁽⁶⁾ are necessary to reduce the waste management problems linked to the heavy metals concerned and the flame retardants concerned. In spite of those measures,** however, significant parts of WEEE will continue to be found in the current disposal routes. Even if WEEE were collected separately and submitted to recycling processes, its content of mercury, cadmium, lead, chromium VI, PBB and PBDE would be likely to pose risks to health or the environment.
- (6) Taking into account technical and economic feasibility, the most effective way of ensuring the significant reduction of risks to health and the environment relating to those substances which can achieve the chosen level of protection in the Community is the substitution of those substances in electrical and electronic equipment by safe or safer materials. Restricting the use of these hazardous substances is likely to enhance the possibilities and economic profitability of recycling of WEEE and decrease the negative health impact on workers in recycling plants.
- (7) The substances covered by this Directive are scientifically well researched and evaluated and have been subject to different measures both at Community and at national level.
- (8) The measures provided for in this Directive take into account existing international guidelines and recommendations and are based on an assessment of available scientific and technical information. The measures are necessary to achieve the chosen level of protection of

⁽¹⁾ OJ C 365 E, 19.12.2000, p. 195 and OJ C 240 E, 28.8.2001, p. 303.

⁽²⁾ OJ C 116, 20.4.2001, p. 38.

⁽³⁾ OJ C 148, 18.5.2001, p. 1.

⁽⁴⁾ Opinion of the European Parliament of 15 May 2001 (OJ C 34 E, 7.2.2002, p. 109), Council Common Position of 4 December 2001 (OJ C 90 E, 16.4.2002, p. 12) and Decision of the European Parliament of 10 April 2002 (not yet published in the Official Journal). Decision of the European Parliament of 18 December 2002 and Decision of the Council of 16 December 2002.

⁽⁵⁾ OJ C 30, 4.2.1988, p. 1.

⁽⁶⁾ See page 24 of this Official Journal.

human and animal health and the environment, having regard to the risks which the absence of measures would be likely to create in the Community. The measures should be kept under review and, if necessary, adjusted to take account of available technical and scientific information.

- (9) This Directive should apply without prejudice to Community legislation on safety and health requirements and specific Community waste management legislation, in particular Council Directive 91/157/EEC of 18 March 1991 on batteries and accumulators containing certain dangerous substances ⁽¹⁾.
- (10) The technical development of electrical and electronic equipment without heavy metals, PBDE and PBB should be taken into account. As soon as scientific evidence is available and taking into account the precautionary principle, the prohibition of other hazardous substances and their substitution by more environmentally friendly alternatives which ensure at least the same level of protection of consumers should be examined.
- (11) Exemptions from the substitution requirement should be permitted if substitution is not possible from the scientific and technical point of view or if the negative environmental or health impacts caused by substitution are likely to outweigh the human and environmental benefits of the substitution. Substitution of the hazardous substances in electrical and electronic equipment should also be carried out in a way so as to be compatible with the health and safety of users of electrical and electronic equipment (EEE).
- (12) As product reuse, refurbishment and extension of lifetime are beneficial, spare parts need to be available.
- (13) The adaptation to scientific and technical progress of the exemptions from the requirements concerning phasing out and prohibition of hazardous substances should be effected by the Commission under a committee procedure.
- (14) The measures necessary for the implementation of this Directive should be adopted in accordance with Council Decision 1999/468/EC of 28 June 1999 laying down the procedures for the exercise of implementing powers conferred on the Commission ⁽²⁾.

HAVE ADOPTED THIS DIRECTIVE:

Article 1

Objectives

The purpose of this Directive is to approximate the laws of the Member States on the restrictions of the use of hazardous substances in electrical and electronic equipment and to contri-

bute to the protection of human health and the environmentally sound recovery and disposal of waste electrical and electronic equipment.

Article 2

Scope

- Without prejudice to Article 6, this Directive shall apply to electrical and electronic equipment falling under the categories 1, 2, 3, 4, 5, 6, 7 and 10 set out in Annex IA to Directive No 2002/96/EC (WEEE) and to electric light bulbs, and luminaires in households.
- This Directive shall apply without prejudice to Community legislation on safety and health requirements and specific Community waste management legislation.
- This Directive does not apply to spare parts for the repair, or to the reuse, of electrical and electronic equipment put on the market before 1 July 2006.

Article 3

Definitions

For the purposes of this Directive, the following definitions shall apply:

- 'electrical and electronic equipment' or 'EEE' means equipment which is dependent on electric currents or electromagnetic fields in order to work properly and equipment for the generation, transfer and measurement of such currents and fields falling under the categories set out in Annex IA to Directive 2002/96/EC (WEEE) and designed for use with a voltage rating not exceeding 1 000 volts for alternating current and 1 500 volts for direct current;
- 'producer' means any person who, irrespective of the selling technique used, including by means of distance communication according to Directive 97/7/EC of the European Parliament and of the Council of 20 May 1997 on the protection of consumers in respect of distance contracts ⁽³⁾:
 - manufactures and sells electrical and electronic equipment under his own brand;
 - resells under his own brand equipment produced by other suppliers, a reseller not being regarded as the 'producer' if the brand of the producer appears on the equipment, as provided for in subpoint (i); or
 - imports or exports electrical and electronic equipment on a professional basis into a Member State.

Whoever exclusively provides financing under or pursuant to any finance agreement shall not be deemed a 'producer' unless he also acts as a producer within the meaning of subpoints (i) to (iii).

⁽¹⁾ OJ L 78, 26.3.1991, p. 38. Directive as amended by Commission Directive 98/101/EC (OJ L 1, 5.1.1999, p. 1).

⁽²⁾ OJ L 184, 17.7.1999, p. 23.

⁽³⁾ OJ L 144, 4.6.1997, p. 19. Directive as amended by Directive 2002/65/EC (L 271, 9.10.2002, p. 16).

Article 4

Prevention

1. Member States shall ensure that, from 1 July 2006, new electrical and electronic equipment put on the market does not contain lead, mercury, cadmium, hexavalent chromium, polybrominated biphenyls (PBB) or polybrominated diphenyl ethers (PBDE). National measures restricting or prohibiting the use of these substances in electrical and electronic equipment which were adopted in line with Community legislation before the adoption of this Directive may be maintained until 1 July 2006.

2. Paragraph 1 shall not apply to the applications listed in the Annex.

3. On the basis of a proposal from the Commission, the European Parliament and the Council shall decide, as soon as scientific evidence is available, and in accordance with the principles on chemicals policy as laid down in the Sixth Community Environment Action Programme, on the prohibition of other hazardous substances and the substitution thereof by more environment-friendly alternatives which ensure at least the same level of protection for consumers.

Article 5

Adaptation to scientific and technical progress

1. Any amendments which are necessary in order to adapt the Annex to scientific and technical progress for the following purposes shall be adopted in accordance with the procedure referred to in Article 7(2):

- (a) establishing, as necessary, maximum concentration values up to which the presence of the substances referred to in Article 4(1) in specific materials and components of electrical and electronic equipment shall be tolerated;
- (b) exempting materials and components of electrical and electronic equipment from Article 4(1) if their elimination or substitution via design changes or materials and components which do not require any of the materials or substances referred to therein is technically or scientifically impracticable, or where the negative environmental, health and/or consumer safety impacts caused by substitution are likely to outweigh the environmental, health and/or consumer safety benefits thereof;
- (c) carrying out a review of each exemption in the Annex at least every four years or four years after an item is added to the list with the aim of considering deletion of materials and components of electrical and electronic equipment from the Annex if their elimination or substitution via design changes or materials and components which do not require any of the materials or substances referred to in

Article 4(1) is technically or scientifically possible, provided that the negative environmental, health and/or consumer safety impacts caused by substitution do not outweigh the possible environmental, health and/or consumer safety benefits thereof.

2. Before the Annex is amended pursuant to paragraph 1, the Commission shall *inter alia* consult producers of electrical and electronic equipment, recyclers, treatment operators, environmental organisations and employee and consumer associations. Comments shall be forwarded to the Committee referred to in Article 7(1). The Commission shall provide an account of the information it receives.

Article 6

Review

Before 13 February 2005, the Commission shall review the measures provided for in this Directive to take into account, as necessary, new scientific evidence.

In particular the Commission shall, by that date, present proposals for including in the scope of this Directive equipment which falls under categories 8 and 9 set out in Annex IA to Directive 2002/96/EC (WEEE).

The Commission shall also study the need to adapt the list of substances of Article 4(1), on the basis of scientific facts and taking the precautionary principle into account, and present proposals to the European Parliament and Council for such adaptations, if appropriate.

Particular attention shall be paid during the review to the impact on the environment and on human health of other hazardous substances and materials used in electrical and electronic equipment. The Commission shall examine the feasibility of replacing such substances and materials and shall present proposals to the European Parliament and to the Council in order to extend the scope of Article 4, as appropriate.

Article 7

Committee

1. The Commission shall be assisted by the Committee set up by Article 18 of Council Directive 75/442/EEC⁽¹⁾.

2. Where reference is made to this paragraph, Articles 5 and 7 of Decision 1999/468/EC shall apply, having regard to Article 8 thereof.

The period provided for in Article 5(6) of Decision 1999/468/EC shall be set at three months.

3. The Committee shall adopt its rules of procedure.

⁽¹⁾ OJ L 194, 25.7.1975, p. 39.

*Article 8***Penalties**

Member States shall determine penalties applicable to breaches of the national provisions adopted pursuant to this Directive. The penalties thus provided for shall be effective, proportionate and dissuasive.

*Article 9***Transposition**

1. Member States shall bring into force the laws, regulations and administrative provisions necessary to comply with this Directive before 13 August 2004. They shall immediately inform the Commission thereof.

When Member States adopt those measures, they shall contain a reference to this Directive or be accompanied by such a reference on the occasion of their official publication. The methods of making such a reference shall be laid down by the Member States.

2. Member States shall communicate to the Commission the text of all laws, regulations and administrative provisions adopted in the field covered by this Directive.

*Article 10***Entry into force**

This Directive shall enter into force on the day of its publication in the *Official Journal of the European Union*.

*Article 11***Addressees**

This Directive is addressed to the Member States.

Done at Brussels, 27 January 2003.

For the European Parliament

The President

P. COX

For the Council

The President

G. DRYS

ANNEX

Applications of lead, mercury, cadmium and hexavalent chromium, which are exempted from the requirements of Article 4(1)

1. Mercury in compact fluorescent lamps not exceeding 5 mg per lamp.
2. Mercury in straight fluorescent lamps for general purposes not exceeding:
 - halophosphate 10 mg
 - triphosphate with normal lifetime 5 mg
 - triphosphate with long lifetime 8 mg.
3. Mercury in straight fluorescent lamps for special purposes.
4. Mercury in other lamps not specifically mentioned in this Annex.
5. Lead in glass of cathode ray tubes, electronic components and fluorescent tubes.
6. Lead as an alloying element in steel containing up to 0,35 % lead by weight, aluminium containing up to 0,4 % lead by weight and as a copper alloy containing up to 4 % lead by weight.
7. — Lead in high melting temperature type solders (i.e. tin-lead solder alloys containing more than 85 % lead),
 - lead in solders for servers, storage and storage array systems (exemption granted until 2010),
 - lead in solders for network infrastructure equipment for switching, signalling, transmission as well as network management for telecommunication,
 - lead in electronic ceramic parts (e.g. piezoelectric devices).
8. Cadmium plating except for applications banned under Directive 91/338/EEC ⁽¹⁾ amending Directive 76/769/EEC ⁽²⁾ relating to restrictions on the marketing and use of certain dangerous substances and preparations.
9. Hexavalent chromium as an anti-corrosion of the carbon steel cooling system in absorption refrigerators.
10. Within the procedure referred to in Article 7(2), the Commission shall evaluate the applications for:
 - Deca BDE,
 - mercury in straight fluorescent lamps for special purposes,
 - lead in solders for servers, storage and storage array systems, network infrastructure equipment for switching, signalling, transmission as well as network management for telecommunications (with a view to setting a specific time limit for this exemption), and
 - light bulbs,as a matter of priority in order to establish as soon as possible whether these items are to be amended accordingly.

⁽¹⁾ OJ L 186, 12.7.1991, p. 59.

⁽²⁾ OJ L 262, 27.9.1976, p. 201.