

APPLICATION FOR CERTIFICATION
On Behalf of

Proware Technologies Co Ltd.

54M Wireless Router

Model Number: MR0-WR542G; MR0-WR541G

FCC ID: WWMWR54XGV2

Prepared for : Proware Technologies Co Ltd.
4/F, Building 7, Section 2, Honghualing Industrial Park,
Xili, Nanshan District, Shenzhen, P.R.C.

Prepared By : Audix Technology (Shenzhen) Co., Ltd.
No. 6, Ke Feng Rd., 52 Block,
Shenzhen Science & Industrial Park,
Nantou, Shenzhen, Guangdong, China

Tel: (0755) 26639496

Report Number : ACS-F09238
Date of Test : Oct.30~Nov.19, 2009
Date of Report : Nov.23, 2009

TABLE OF CONTENTS

Description	Page
1. SUMMARY OF STANDARDS AND RESULTS.....	1-1
1.1. Description of Standards and Results	1-1
2. GENERAL INFORMATION	2-2
2.1. Description of Device (EUT)	2-2
2.2. Test information	2-3
2.3. Data rate VS power	2-3
2.4. Tested Supporting System Details	2-4
2.5. Test Facility	2-5
2.6. Measurement Uncertainty (95% confidence levels, k=2)	2-5
3. POWER LINE CONDUCTED EMISSION TEST	3-1
3.1. Test Equipments.....	3-1
3.2. Block Diagram of Test Setup	3-1
3.3. Power Line Conducted Emission Test Limits	3-1
3.4. Configuration of EUT on Test	3-2
3.5. Operating Condition of EUT	3-2
3.6. Test Procedure.....	3-2
3.7. Power Line Conducted Emission Test Results	3-2
4. RADIATED EMISSION TEST	4-1
4.1. Test Equipment	4-1
4.2. Block Diagram of Test Setup	4-1
4.3. Radiated Emission Limit.....	4-2
4.4. EUT Configuration on Test.....	4-3
4.5. Operating Condition of EUT.....	4-3
4.6. Test Procedure.....	4-3
4.7. Radiated Emission Test Results	4-4
5. CONDUCTED SPURIOUS EMISSIONS.....	5-1
5.1. Test Equipment	5-1
5.2. Limit.....	5-1
5.3. Test Procedure.....	5-1
5.4. Test result.....	5-1
6. BAND EDGE COMPLIANCE TEST	6-1
6.1. Test Equipment	6-1
6.2. Limit.....	6-1
6.3. Test Produce.....	6-1
6.4. Test Results	6-1
7. 6dB Bandwidth Test.....	7-1
7.1. Test Equipment	7-1
7.2. Limit.....	7-1
7.3. Test Procedure.....	7-1
7.4. Test Results	7-1
8. OUTPUT POWER TEST.....	8-1
8.1. Test Equipment	8-1
8.2. Limit(FCC Part 15C 15.247 b(3)).....	8-1
8.3. Test Procedure.....	8-1
8.4. Test Results	8-2
9. POWER SPECTRAL DENSITY TEST	9-1

9.1. Test Equipment9-1

9.2. Limit.....9-1

9.3. Test Procedure.....9-1

9.4. Test Results9-2

10. ANTENNA REQUIREMENT 10-1

11. MPE ESTIMATION 11-1

11.1. Limit for General Population/ Uncontrolled Exposures 11-1

11.2. Estimation Result 11-1

12. DEVIATION TO TEST SPECIFICATIONS..... 12-1

13. PHOTOGRAPH OF TEST 13-1

13.1. Photos of Power Line Conducted Emission Test 13-1

13.2. Photos of Radiated Emission Test..... 13-2

14. PHOTOGRAPH OF EUT 14-1

TEST REPORT CERTIFICATION

Applicant : Proware Technologies Co Ltd.
 Manufacturer : Proware Technologies Co Ltd.
 EUT Description : 54M Wireless Router
 FCC ID : WMMWR54XGV2

(A) MODEL NO. : MR0-WR542G; MR0-WR541G
 (B) SERIAL NO. : N/A
 (C) POWER SUPPLY : DC 9V From Adapter
 (D) TEST VOLTAGE : DC 9V From Adapter Input
 AC 120V/60Hz

Test Procedure Used:

FCC Rules and Regulations Part 15 Subpart C 2008

The device described above is tested by AUDIX TECHNOLOGY (SHENZHEN) CO., LTD. to determine the maximum emission levels emanating from the device. The maximum emission levels are compared to the FCC Part 15 Subpart C limits both radiated and conducted emissions.

The test results are contained in this test report and AUDIX TECHNOLOGY (SHENZHEN) CO., LTD. is assumed full responsibility for the accuracy and completeness of these tests. Also, this report shows that the Equipment Under Test (EUT) is to be technically compliant with the FCC requirements.

This report applies to above tested sample only. This report shall not be reproduced in part without written approval of AUDIX TECHNOLOGY (SHENZHEN) CO., LTD.

Date of Test : Oct.30~ Nov.19, 2009

Prepared by : Edie Huang
 Edie Huang / Assistant

Reviewer : Jamy Yu
 Jamy Yu / Senior Engineer



Approved & Authorized Signer : Ken Lu
 Ken Lu / Manager

1. SUMMARY OF STANDARDS AND RESULTS

1.1. Description of Standards and Results

The EUT have been tested according to the applicable standards as referenced below.

Description of Test Item	Standard	Results
Power Line Conducted Emission Test	FCC Part 15: 15.207 ANSI C63.4: 2003 KDB558074	PASS
Radiated Emission Test	FCC Part 15: 15.209 ANSI C63.4: 2003 KDB558074	PASS
Band Edge Compliance Test	FCC Part 15: 15.247 KDB558074	PASS
Conducted spurious emissions test	FCC Part 15: 15.247 KDB558074	PASS
6dB Bandwidth Test	FCC Part 15: 15.247 KDB558074	PASS
Output Power Test	FCC Part 15: 15.247 KDB558074	PASS
Power Spectral Density Test	FCC Part 15: 15.247 KDB558074	PASS
Antenna requirement	FCC Part 15: 15.203	PASS

2. GENERAL INFORMATION

2.1. Description of Device (EUT)

Product Name	: 54M Wireless Router
Model Number	: MR0-WR542G; MR0-WR541G The differences between them are: MR0-WR541G with fixed antenna and MR0-WR542G with detachable antenna. And this two antennas are same type and have same gain and other characteristic.
Test Model	: MR0-WR542G
FCC ID	: WMMWR54XGV2
Operation Frequency	: IEEE 802.11b/g: 2412MHz---2462MHz
Channel Number	: IEEE 802.11b/g: 11 Channels
Modulation Technology	: IEEE 802.11b: DSSS(CCK,DQPSK,DBPSK) IEEE 802.11g: OFDM(64QAM, 16QAM, QPSK, BPSK)
Output Power	: IEEE 802.11b: 17.35dBm IEEE 802.11g: 22.56dBm
Antenna and Gain	: One PCB antenna (Only used for Receive), One Dipole Antenna (Used for Receive and Transmit), 5dBi gain for Dipole antenna.
Applicant	: Proware Technologies Co Ltd. 4/F, Building 7, Section 2, Honghualing Industrial Park, Xili, Nanshan District, Shenzhen, P.R.C.
Manufacturer	: Proware Technologies Co Ltd. 4/F, Building 7, Section 2, Honghualing Industrial Park, Xili, Nanshan District, Shenzhen, P.R.C.
Power Adapter	: Manufacturer: LEADER ELECTRONICS INC. M/N: MU05-N090060-A1 Cable: Unshielded, Undetachable, 1.5m
Date of Test	: Oct.30~Nov.19, 2009
Date of Receipt	: Oct.21, 2009
Sample Type	: Prototype production

2.2. Test information

The test software “art.exe” was used to control EUT work in Continuous TX mode, and select test channel, wireless mode and data rate.

Tested mode, channel, and data rate information			
Mode	data rate (Mbps)(see Note)	Channel	Frequency (MHz)
IEEE 802.11b	1	Low :CH1	2412
	1	Middle: CH6	2437
	1	High: CH11	2462
IEEE 802.11g	6	Low :CH1	2412
	6	Middle: CH6	2437
	6	High: CH11	2462

Note: According exploratory test, EUT will have maximum output power in those data rate, so those data rate were used for all test.

2.3. Date rate VS power

Mode	Data rate(Mbps)	CH	Level (dBm)	Limit (dBm)
11b	1	CH6	17.35	30
	2	CH6	17.14	30
	5.5	CH6	17.21	30
	11	CH6	17.08	30
11g	6	CH6	22.56	30
	9	CH6	22.32	30
	12	CH6	22.12	30
	18	CH6	22.34	30
	24	CH6	22.31	30
	36	CH6	22.50	30
	48	CH6	22.18	30
	54	CH6	22.25	30

When IEEE 802.11b's data rate was 1Mbps ; IEEE 802.11g's data rate was 6Mbps, the EUT have maximum output power and all the test was performed in this data rate set.

2.4. Tested Supporting System Details

2.4.1. PERSONAL COMPUTER

EMC CODE	:	Test PC J
M/N	:	DCTA
S/N	:	3Q5932X
Manufacturer	:	Dell
Power cord	:	Unshielded, Detachabled , 1.8m
FCC ID	:	By DoC
BSMI ID	:	R 33002

2.4.2. CABLE

Lan Cable	:	Unshielded, Detachabled, 10m
-----------	---	------------------------------

2.5. Test Facility

Site Description

Name of Firm	:	Audix Technology (Shenzhen) Co., Ltd. No. 6, Ke Feng Rd., 52 Block, Shenzhen Science & Industrial Park, Nantou, Shenzhen, Guangdong, China
3m Anechoic Chamber	:	Mar.31, 2009 File on Federal Communication Commission Registration Number: 90454
3m & 10m Anechoic Chamber	:	Jan. 31, 2007 File on Federal Communication Commission Registration Number: 794232
EMC Lab.	:	Accredited by DATech, German Registration Number: DAT-P-091/99-01 Feb. 02, 2009 Accredited by NVLAP, USA NVLAP Code: 200372-0 Apr. 01, 2009

2.6. Measurement Uncertainty (95% confidence levels, k=2)

Test Item	Uncertainty
Uncertainty for Conduction emission test in No. 1 Conduction	2.40dB
Uncertainty for Radiation Emission test in 3m chamber	3.78 dB (Polarize: V)
	4.20 dB (Polarize: H)
Uncertainty for Radiated Spurious Emission test in RF chamber	2.70 dB (Bilog antenna 30M~1000MHz)
	2.26 dB (Horn antenna 1000M~25000MHz)
Uncertainty for Conduction Spurious emission test	2.10 dB
Uncertainty for Output power test	0.94 dB
Uncertainty for Power density test	2.10 dB
Uncertainty for Temperature and humidity test	2%
	1°C
Uncertainty for Bandwidth test	1×10^{-9}
Uncertainty for DC power test	0.042 %
Uncertainty for test site temperature and humidity	0.6°C
	3%

3. POWER LINE CONDUCTED EMISSION TEST

3.1. Test Equipments

Item	Equipment	Manufacturer	Model No.	Serial No.	Last Cal.	Cal. Interval
1	Test Receiver	Rohde & Schwarz	ESHS20	836600/006	May.08, 09	1 Year
2	L.I.S.N.#2	Kyoritsu	KNW-407	8-1636-1	May.08, 09	1 Year
3	Terminator	Hubersuhner	50Ω	No. 1	May.08, 09	1 Year
4	RF Cable	Fujikura	3D-2W	LISN Cable 1#	May.08, 09	1Year
5	Coaxial Switch	Anritsu	MP59B	M55367	May.08, 09	1 Year
6	Pulse Limiter	Rohde & Schwarz	ESH3-Z2	100341	May.08, 09	1 Year

3.2. Block Diagram of Test Setup

3.2.1. Block diagram of connection between the EUT and simulators

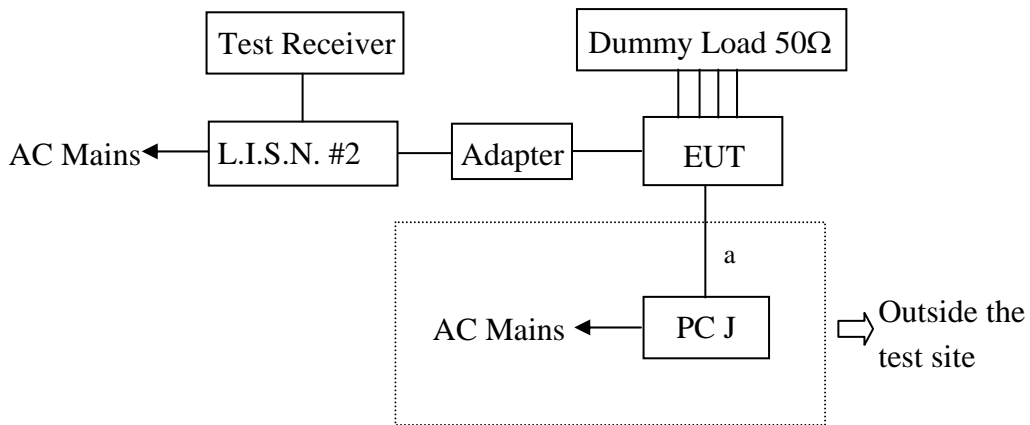

a: LAN Cable 10m

(EUT: 54M Wireless Router)

3.3. Power Line Conducted Emission Test Limits

Frequency	Maximum RF Line Voltage	
	Quasi-Peak Level dB(μV)	Average Level dB(μV)
150kHz ~ 500kHz	66 ~ 56*	56 ~ 46*
500kHz ~ 5MHz	56	46
5MHz ~ 30MHz	60	50

Notes: 1. * Decreasing linearly with logarithm of frequency.

2. The lower limit shall apply at the transition frequencies.

3.4.Configuration of EUT on Test

The following equipment are installed on Power Line Conducted Emission Test to meet the commission requirement and operating regulations in a manner which tends to maximize its emission characteristics in a normal application.

3.4.1. 54M Wireless Router (EUT)

Model Number : MR0-WR542G
Serial Number : N/A

3.4.2. Support Equipment : As Tested Supporting System Detail, in Section 2.3.

3.5.Operating Condition of EUT

3.5.1. Setup the EUT and simulator as shown as Section 3.2.

3.5.2. Turned on the power of all equipment.

3.5.3. PC J run test software to control EUT work in Tx mode.

3.6.Test Procedure

The EUT was placed on a non-metallic table, 80cm above the ground plane. The EUT Power Via Adapter connected to the power mains through a line impedance stabilization network (L.I.S.N. 2#). This provides a 50 ohm coupling impedance for the EUT (Please refer the block diagram of the test setup and photographs). The AC line are checked to find out the maximum conducted emission. In order to find the maximum emission levels, the relative positions of equipment and all of the interface cables shall be changed according to ANSI C63.4: 2003 on Conducted Emission Test.

The bandwidth of test receiver (R & S ESHS20) is set at 10kHz.

The frequency range from 150kHz to 30MHz is checked.

The test result are reported on Section 3.7.,

3.7.Power Line Conducted Emission Test Results

PASS. (All emissions not reported below are too low against the prescribed limits.)



NO.6 Ke Feng Road,Block 52,
Shenzhen Science&Industry Park
Nantou, Shenzhen,Guang dong, China.
Tel:+86-755-26639495
Fax:+86-755-26632877
Postcode:518057

Data: 2 File: D:\DATA\2009 Report\T\TP-LINK\ACS9Q1514.EM6 (16)

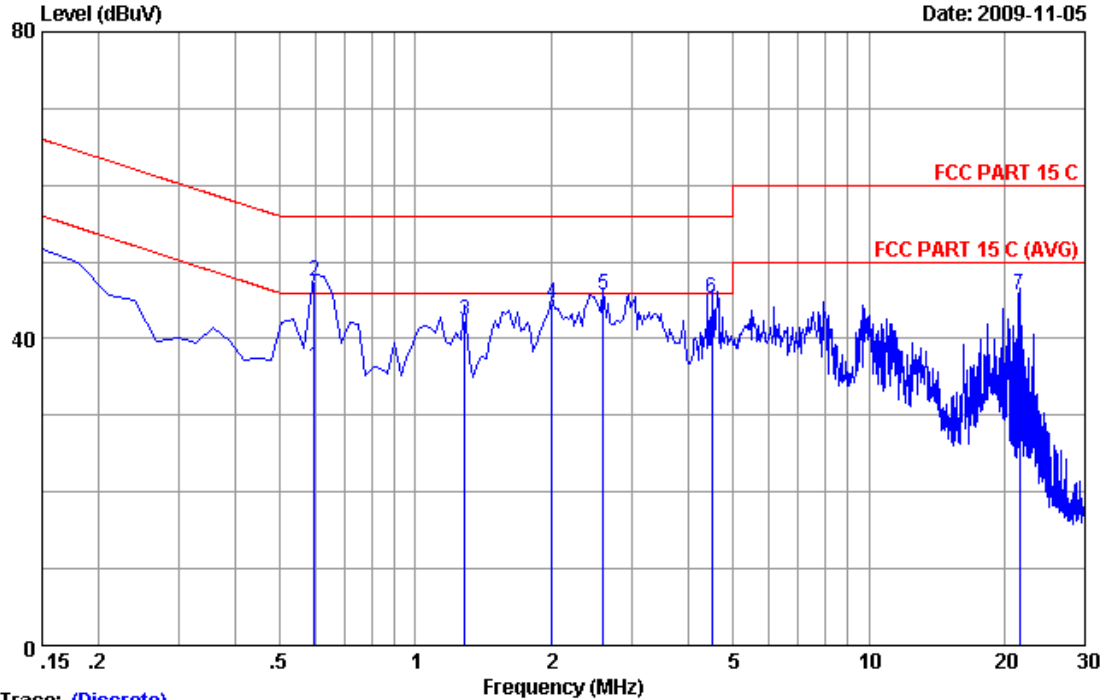

Trace: (Discrete)

Site no :Audix No.1 Conduction Data no :2
 Dis./Ant. **: 2009 KNW407 VB
 Limit :FCC PART 15 C
 Env./Ins. :Temp:23'C Humi:54% Engineer :Sunny-lu
 EUT :54M Wireless Router M/N:MRO-WR542G
 Power Rating :DC 9V From Adapter Input AC 120V/60Hz
 Test Mode :Tx Mode
 :Memo:LINE

No	Freq (MHz)	LISN Factor (dB)	Cable Loss (dB)	Reading (dBuV)	Emission Level (dBuV)	Limits (dBuV)	Margin (dB)	Remark
1	0.59775	0.35	9.89	26.12	36.36	46.00	9.64	Average
2	0.59775	0.35	9.89	37.20	47.44	56.00	8.56	QP
3	1.284	0.35	9.89	32.18	42.42	56.00	13.58	QP
4	2.001	0.36	9.90	34.29	44.55	56.00	11.45	QP
5	2.598	0.37	9.90	35.38	45.65	56.00	10.35	QP
6	4.508	0.37	9.91	35.05	45.33	56.00	10.67	QP
7	21.493	0.58	10.02	35.08	45.68	60.00	14.32	QP

Remarks: 1.Emission Level=LISN Factor+Cable Loss(Include 10dB pulse limit)+Reading
 2.If the average limit is met when using a quasi-peak detector.
 the EUT shall be deemed to meet both limits and measurement
 with average detector is unnecessary.



NO.6 Ke Feng Road,Block 52,
Shenzhen Science&Industry Park
Nantou, Shenzhen,Guang dong, China.
Tel:+86-755-26639495
Fax:+86-755-26632877
Postcode:518057

Data: 1 File: D:\DATA\2009 Report\TP-LINK\ACS9Q1514.EM6 (16)

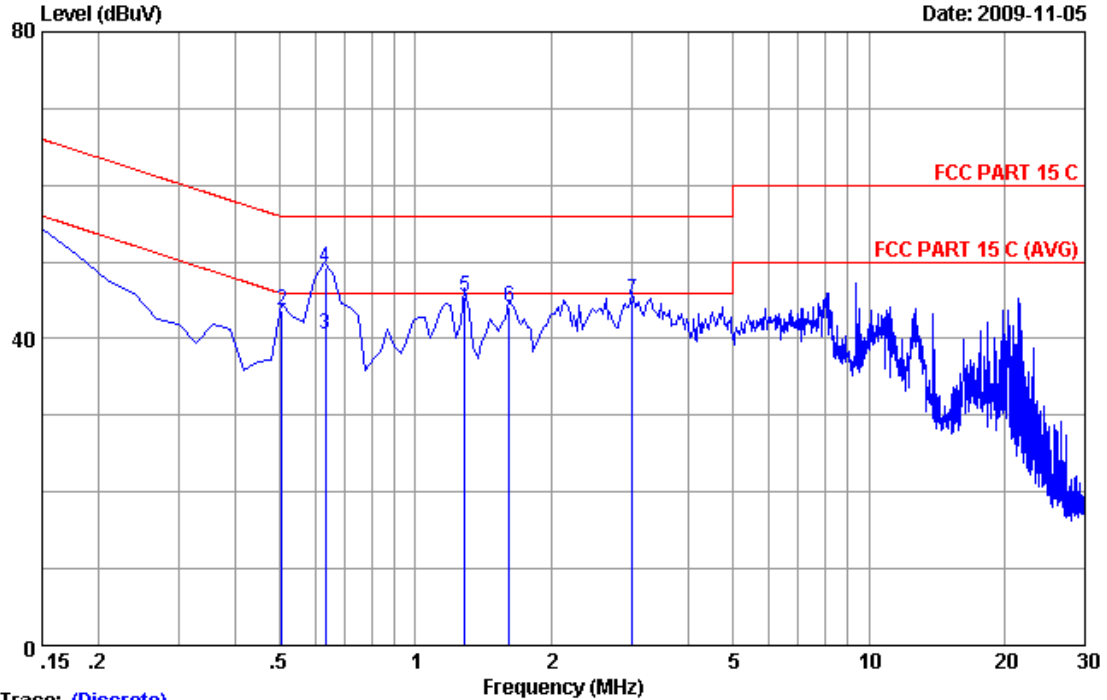

Trace: (Discrete)

Site no :Audix No.1 Conduction Data no :1
 Dis./Ant. **: 2009 KNW407 VA
 Limit :FCC PART 15 C
 Env./Ins. :Temp:23'C Humi:54% Engineer :Sunny-lu
 EUT :54M Wireless Router M/N:MRO-WR542G
 Power Rating :DC 9V From Adapter Input AC 120V/60Hz
 Test Mode :Tx Mode
 :Memo:NEUTRAL

No	Freq (MHz)	LISN Factor (dB)	Cable Loss (dB)	Reading (dBuV)	Emission Level (dBuV)	Limits (dBuV)	Margin (dB)	Remark
1	0.15000	0.47	9.88	42.96	53.31	66.00	12.69	QP
2	0.50820	0.34	9.89	33.44	43.67	56.00	12.33	QP
3	0.63400	0.36	9.89	30.20	40.45	46.00	5.55	Average
4	0.63400	0.36	9.89	38.90	49.15	56.00	6.85	QP
5	1.284	0.34	9.89	35.26	45.49	56.00	10.51	QP
6	1.613	0.35	9.89	33.83	44.07	56.00	11.93	QP
7	3.016	0.36	9.91	34.82	45.09	56.00	10.91	QP

Remarks: 1.Emission Level=LISN Factor+Cable Loss(Include 10dB pulse limit)+Reading
 2.If the average limit is met when using a quasi-peak detector.
 the EUT shall be deemed to meet both limits and measurement
 with average detector is unnecessary.

4. RADIATED EMISSION TEST

4.1. Test Equipment

Frequency rang: 30~1000MHz

Item	Equipment	Manufacturer	Model No.	Serial No.	Last Cal.	Cal. Interval
1	3#Chamber	AUDIX	N/A	N/A	Dec.05,08	1 Year
2	EMI Spectrum	Agilent	E4407B	MY41440292	May.08, 09	1 Year
3	Test Receiver	Rohde & Schwarz	ESVS10	834468/011	May.08, 09	1 Year
4	Amplifier	HP	8447D	2648A04738	May.08, 09	1 Year
5	Bilog Antenna	Schaffner	CBL6111C	2598	Nov.10, 08	1 Year
6	RF Cable	MIYAZAKI	8D-FB	3# Chamber No.1	May.08, 09	1 Year
7	Coaxial Switch	Anritsu	MP59B	M73989	May.08, 09	1 Year

Frequency rang: above 1000MHz

Item	Equipment	Manufacturer	Model No.	Serial No.	Last Cal.	Cal. Interval
1	Spectrum Analyzer	Agilent	E4446A	US44300459	May.08, 09	1 Year
2	Horn Antenna	EMCO	3115	9607-4877	May.27, 08	1.5 Year
3	Horn Antenna	EMCO	3116	00060088	May.27, 08	1.5Year
4	Amplifier	Agilent	8449B	3008A08495	Aug.04,09	1 Year
5	RF Cable	Hubersuhner	SUCOFLEX102	28620/2	May.08, 09	1 Year
6	RF Cable	Hubersuhner	SUCOFLEX102	271471/4	May.08, 09	1 Year
7	RF Cable	Hubersuhner	SUCOFLEX102	29086/2	May.08, 09	1 Year

4.2. Block Diagram of Test Setup

4.2.1. Block diagram of connection between the EUT and simulators

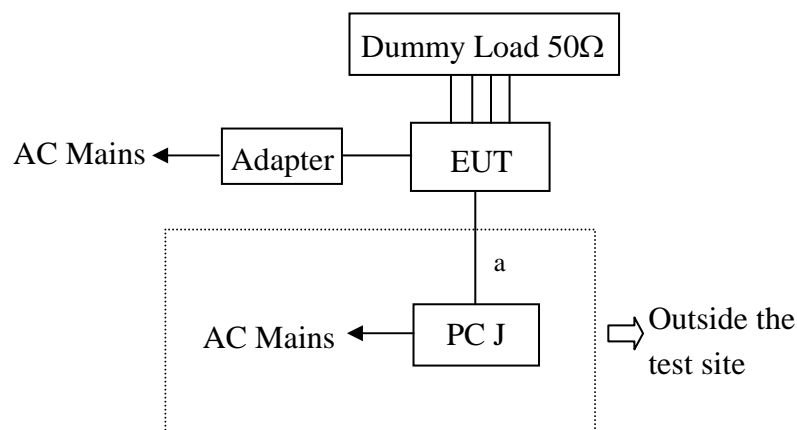

a: LAN Cable 10m

(EUT: 54M Wireless Router)

4.2.2. In Anechoic Chamber

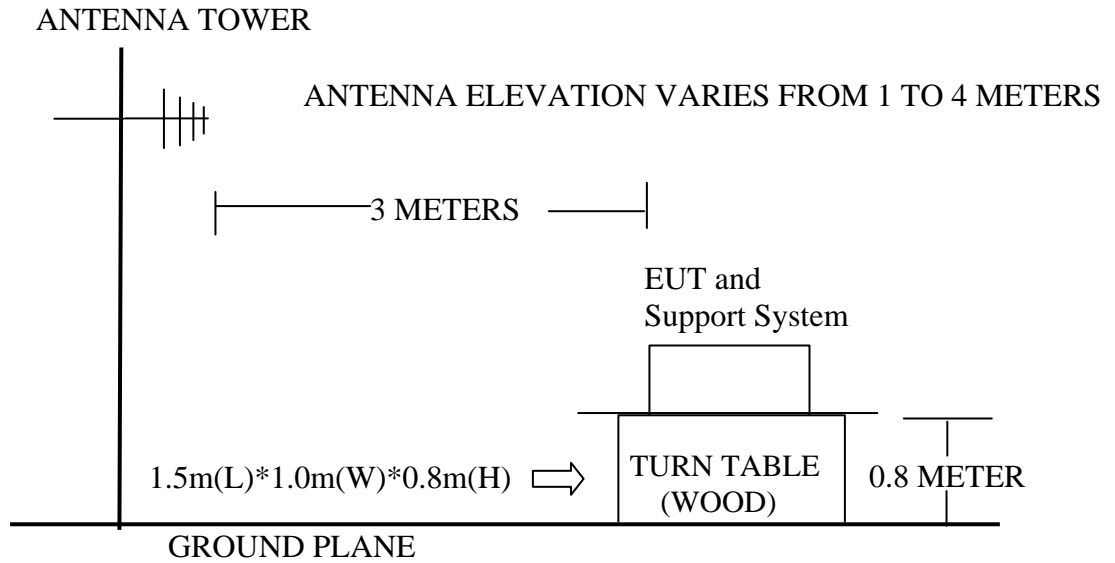

4.3. Radiated Emission Limit

4.3.1. 15.209 limits

FREQUENCY MHz	DISTANCE Meters	FIELD STRENGTHS LIMIT	
		μV/m	dB(μV)/m
30 ~ 88	3	100	40.0
88 ~ 216	3	150	43.5
216 ~ 960	3	200	46.0
960 ~ 1000	3	500	54.0
Above 1000	3	74.0 dB(μV)/m (Peak) 54.0 dB(μV)/m (Average)	

- Remark :
- (1) Emission level dBμV = 20 log Emission level μV/m
 - (2) The smaller limit shall apply at the cross point between two frequency bands.
 - (3) Distance is the distance in meters between the measuring instrument, antenna and the closest point of any part of the device or system.

4.3.2. 15.205 Restricted bands of operation

MHz	MHz	MHz	GHz
0.090 - 0.110	16.42 - 16.423	399.9 - 410	4.5 - 5.15
¹ 0.495 - 0.505	16.69475 - 16.69525	608 - 614	5.35 - 5.46
2.1735 - 2.1905	16.80425 - 16.80475	960 - 1240	7.25 - 7.75
4.125 - 4.128	25.5 - 25.67	1300 - 1427	8.025 - 8.5
4.17725 - 4.17775	37.5 - 38.25	1435 - 1626.5	9.0 - 9.2
4.20725 - 4.20775	73 - 74.6	1645.5 - 1646.5	9.3 - 9.5
6.215 - 6.218	74.8 - 75.2	1660 - 1710	10.6 - 12.7
6.26775 - 6.26825	108 - 121.94	1718.8 - 1722.2	13.25 - 13.4
6.31175 - 6.31225	123 - 138	2200 - 2300	14.47 - 14.5
8.291 - 8.294	149.9 - 150.05	2310 - 2390	15.35 - 16.2
8.362 - 8.366	156.52475 - 156.52525	2483.5 - 2500	17.7 - 21.4
8.37625 - 8.38675	156.7 - 156.9	2690 - 2900	22.01 - 23.12
8.41425 - 8.41475	162.0125 - 167.17	3260 - 3267	23.6 - 24.0
12.29 - 12.293	167.72 - 173.2	3332 - 3339	31.2 - 31.8
12.51975 - 12.52025	240 - 285	3345.8 - 3358	36.43 - 36.5
12.57675 - 12.57725	322 - 335.4	3600 - 4400	(²)

All the emissions appearing within 15.205 restricted frequency bands shall not exceed the limits shown in 15.209, all the other emissions shall be at least 20dB below the fundamental emissions, or comply with 15.209 limits.

4.4.EUT Configuration on Test

The following equipment are installed on Radiated Emission Test to meet the commission requirements and operating regulations in a manner which tends to maximize its emission characteristics in normal application.

4.4.1. 54M Wireless Router (EUT)

Model Number : MR0-WR542G
Serial Number : N/A

4.4.2. Support Equipment : As Tested Supporting System Detail, in Section 2.3.

4.5. Operating Condition of EUT

4.5.1. Setup the EUT and simulator as shown as Section 4.2.

4.5.2. Turned on the power of all equipment.

4.5.3. PC J run test software to control EUT work in Tx mode.

4.6. Test Procedure

EUT and its simulators are placed on a turn table, which is 0.8 meter high above ground. The turn table can rotate 360 degrees to determine the position of the maximum emission level. Power on the EUT and let it working in test mode, then test it. EUT is set 3 meters away from the receiving antenna, which is mounted on a antenna tower. The antenna can be moved up and down between 1 meter and 4 meters to find out the maximum emission level. Broadband antenna (calibrated bilog antenna) is used as receiving antenna. Both horizontal and vertical polarization of the antenna are set on test.

The bandwidth of the EMI test receiver (R&S ESVS10) is set at 120kHz for frequency range from 30MHz to 1000 MHz.

The bandwidth of the Spectrum's VBW is set at 1MHz and RBW is set at 1MHz for peak emissions measurement above 1GHz and 1MHz RBW, 10Hz VBW for average emissions measure above 1GHz

The frequency range from 30MHz to 10th harmonic (25GHz) are checked. and no any emissions were found from 18GHz to 25 GHz, So the radiated emissions from 18GHz to 25GHz were not record.

4.7.Radiated Emission Test Results

PASS.

All the emissions from 30MHz to 25 GHz were comply with 15.209 limits.

Frequency: 30MHz~1GHz



No.6 Ke Feng Road,Block 52,
ShenZhen Science & Industry Park
Noutou,ShenZhen,GuangDong,China
Tel:+86-755-26639495-7
Fax:+86-755-26632877
Postcode:518057

Data: 4 File: D:\2009 Report Data\TTP-LINK\ACS9Q1514.EM6 (4)

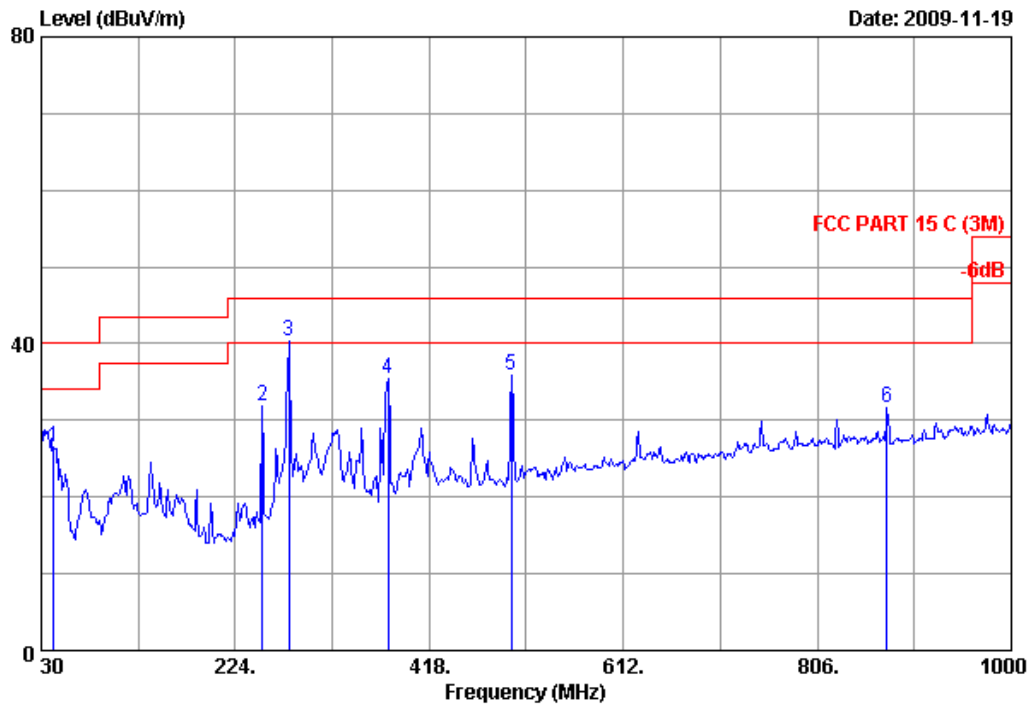

Site no. : 3m chamber Data no. : 4
 Dis. / Ant. : 3m CBL6111C Ant. pol. : HORIZONTAL
 Limit : FCC PART 15 C (3M)
 Env. / Ins. : 24°C/56% Engineer : Cary Luo
 EUT : 54M Wireless Router
 Power Rating : DC 9V From Adapter Input AC 120V/60Hz
 Test Mode : Tx Mode
 M/N: MRO-WR542G

No.	Freq. (MHz)	Ant. Factor (dB/m)	Cable Loss (dB)	Reading (dBuV)	Emission Level (dBuV/m)	Limits (dBuV/m)	Margin (dB)	Remark
1	42.610	12.79	0.61	39.91	26.42	40.00	13.58	QP
2	251.160	12.75	1.64	44.35	31.81	46.00	14.19	QP
3	277.350	13.13	1.69	52.47	40.32	46.00	5.68	QP
4	377.260	15.57	1.88	44.96	35.38	46.00	10.62	QP
5	500.450	18.04	2.25	42.68	35.90	46.00	10.10	QP
6	875.840	22.55	3.15	32.97	31.64	46.00	14.36	QP

Remarks: 1. Emission Level= Antenna Factor + Cable Loss + Reading.
 2. The emission levels that are 20dB below the official limit are not reported.



No.6 Ke Feng Road,Block 52,
ShenZhen Science & Industry Park
Noutou,ShenZhen,GuangDong,China
Tel:+86-755-26639495-7
Fax:+86-755-26632877
Postcode:518057

Data: 3 File: D:\2009 Report Data\T\TP-LINK\ACS9Q1514.EM6 (4)

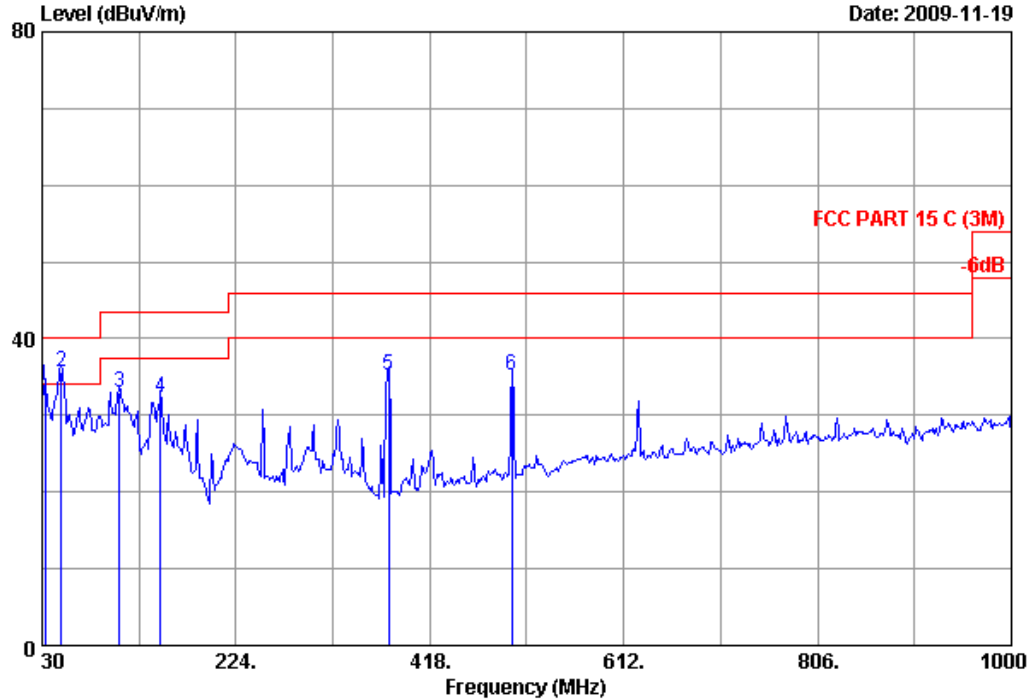

Site no. : 3m chamber Data no. : 3
 Dis. / Ant. : 3m CBL6111C Ant. pol. : VERTICAL
 Limit : FCC PART 15 C (3M)
 Env. / Ins. : 24°C/56% Engineer : Cary Luo
 EUT : 54M Wireless Router
 Power Rating : DC 9V From Adapter Input AC 120V/60Hz
 Test Mode : Tx Mode
 M/N: MRO-WR542G

No.	Freq. (MHz)	Ant. Factor (dB/m)	Cable Loss (dB)	Reading (dBuV)	Emission Level (dBuV/m)	Limits (dBuV/m)	Margin (dB)	Remark
1	32.910	18.17	0.54	42.06	33.85	40.00	6.15	QP
2	49.400	9.57	0.65	52.23	35.58	40.00	4.42	QP
3	107.600	11.04	0.93	47.66	32.92	43.50	10.58	QP
4	148.340	11.62	1.08	46.37	32.30	43.50	11.20	QP
5	377.260	15.57	1.88	44.90	35.32	46.00	10.68	QP
6	500.450	18.04	2.25	41.98	35.20	46.00	10.80	QP

Remarks: 1. Emission Level= Antenna Factor + Cable Loss + Reading.
 2. The emission levels that are 20dB below the official limit are not reported.

Frequency: 1GHz~18GHz



No.6 Ke Feng Road,Block 52,
ShenZhen Science & Industry Park
Noutou,ShenZhen, GuangDong, China
Tel:+86-755-26639495-7
Fax:+86-755-26632877
Postcode:518057

Data: 1 File: E:\2009 report data\T\TP-LINK\ACS9Q1514.EM6 (56)

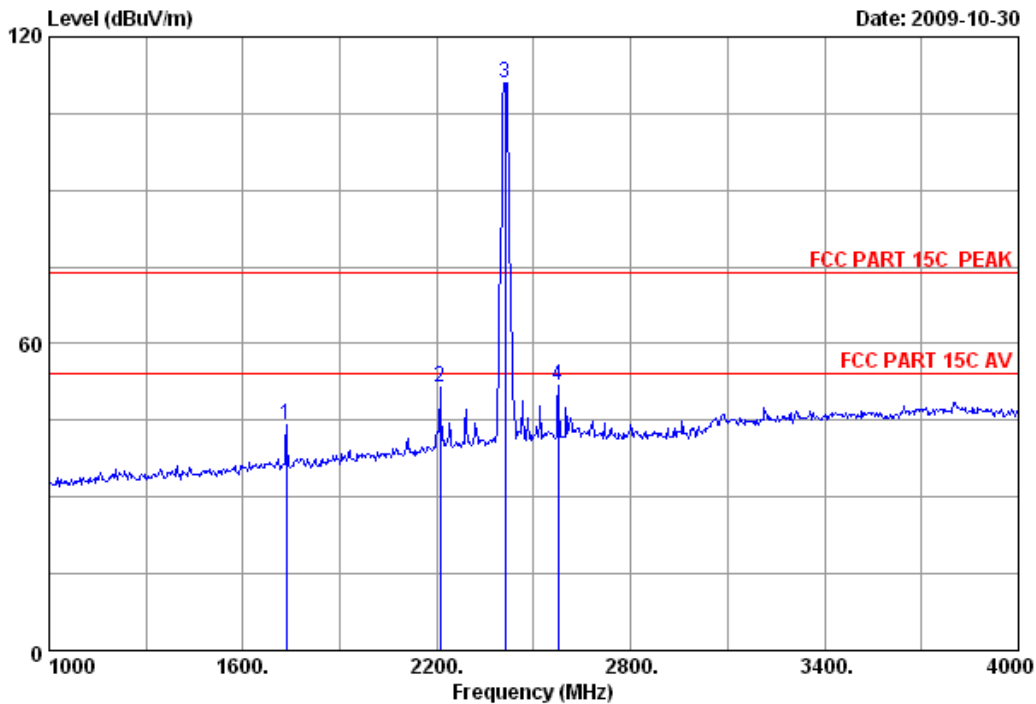

Site no. : 3m Chamber Data no. : 1
 Dis. / Ant. : 3m 3115(0905) Ant. pol. : VERTICAL
 Limit : FCC PART 15C PEAK
 Env. / Ins. : 23°C/54% Engineer : Sunny-lu
 EUT : 54M Wireless Router
 Power : DC 9V From Adapter Input AC 120V/60Hz
 Test mode : IEEE802.11b CH1 2412MHz Tx
 M/N : MRO-WR542G

	Ant. Freq. (MHz)	Factor (dB/m)	Cable loss (dB)	Amp. Factor (dB)	Reading (dbuv)	Emission Level (dBuV/m)	Limits (dBuV/m)	Margin (dB)	Remark
1	1735.000	26.83	7.31	36.36	46.35	44.13	74.00	29.87	Peak
2	2209.000	28.19	8.36	36.02	50.86	51.39	74.00	22.61	Peak
3	2412.000	28.48	8.60	35.95	109.87	111.00	74.00	-37.00	Peak
4	2575.000	28.87	9.21	35.78	49.42	51.72	74.00	22.28	Peak

Remarks:

1. Emission Level= Antenna Factor + Cable Loss -Amp Factor + Reading.
2. The emission levels that are 20dB below the official limit are not reported.



No.6 Ke Feng Road,Block 52,
ShenZhen Science & Industry Park
Noutou,ShenZhen,GuangDong,China
Tel:+86-755-26639495-7
Fax:+86-755-26632877
Postcode:518057

Data: 2 File: E:\2009 report data\TP-LINK\ACS9Q1514.EM6 (56)

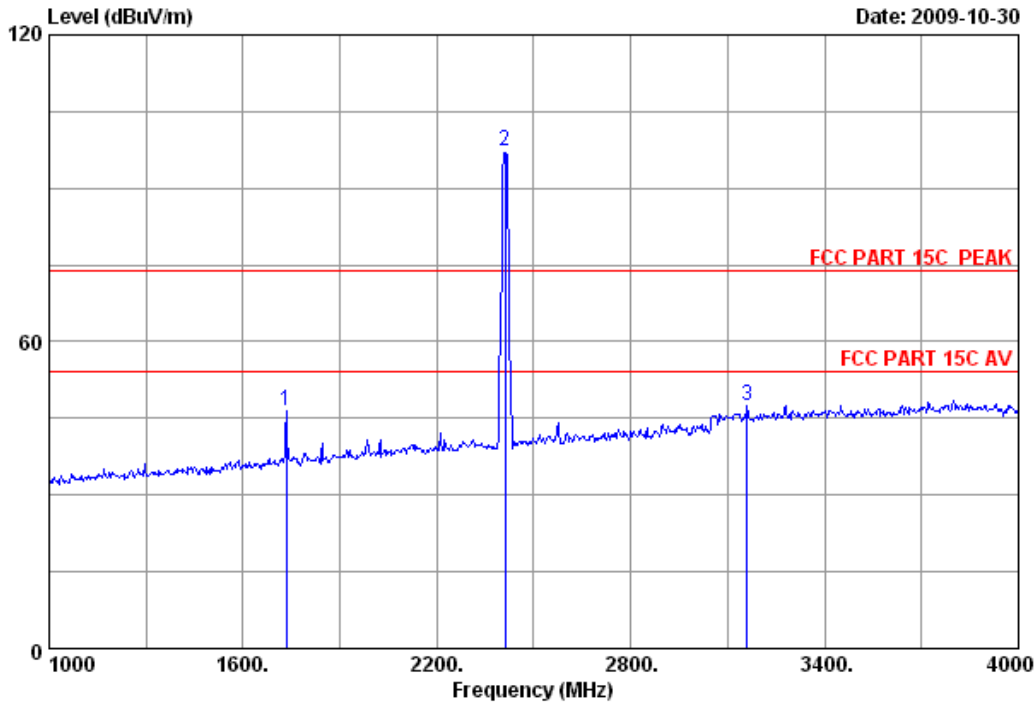

Site no. : 3m Chamber Data no. : 2
 Dis. / Ant. : 3m 3115(0905) Ant. pol. : HORIZONTAL
 Limit : FCC PART 15C PEAK
 Env. / Ins. : 23°C/54% Engineer : Sunny-lu
 EUT : 54M Wireless Router
 Power : DC 9V From Adapter Input AC 120V/60Hz
 Test mode : IEEE802.11b CH1 2412MHz Tx
 M/N : MRO-WR542G

	Freq. (MHz)	Ant. Factor (dB/m)	Cable loss (dB)	Amp. Factor (dB)	Reading (dbuv)	Emission			Remark
						Level (dBuV/m)	Limits (dBuV/m)	Margin (dB)	
1	1735.000	26.83	7.31	36.36	48.74	46.52	74.00	27.48	Peak
2	2412.000	28.48	8.60	35.95	96.13	97.26	74.00	-23.26	Peak
3	3160.000	30.63	9.82	35.80	42.70	47.35	74.00	26.65	Peak

Remarks:

1. Emission Level= Antenna Factor + Cable Loss -Amp Factor + Reading.
2. The emission levels that are 20dB below the official limit are not reported.



No.6 Ke Feng Road,Block 52,
ShenZhen Science & Industry Park
Noutou,ShenZhen,GuangDong,China
Tel:+86-755-26639495-7
Fax:+86-755-26632877
Postcode:518057

Data: 3 File: E:\2009 report data\T\TP-LINK\ACS9Q1514.EM6 (56)

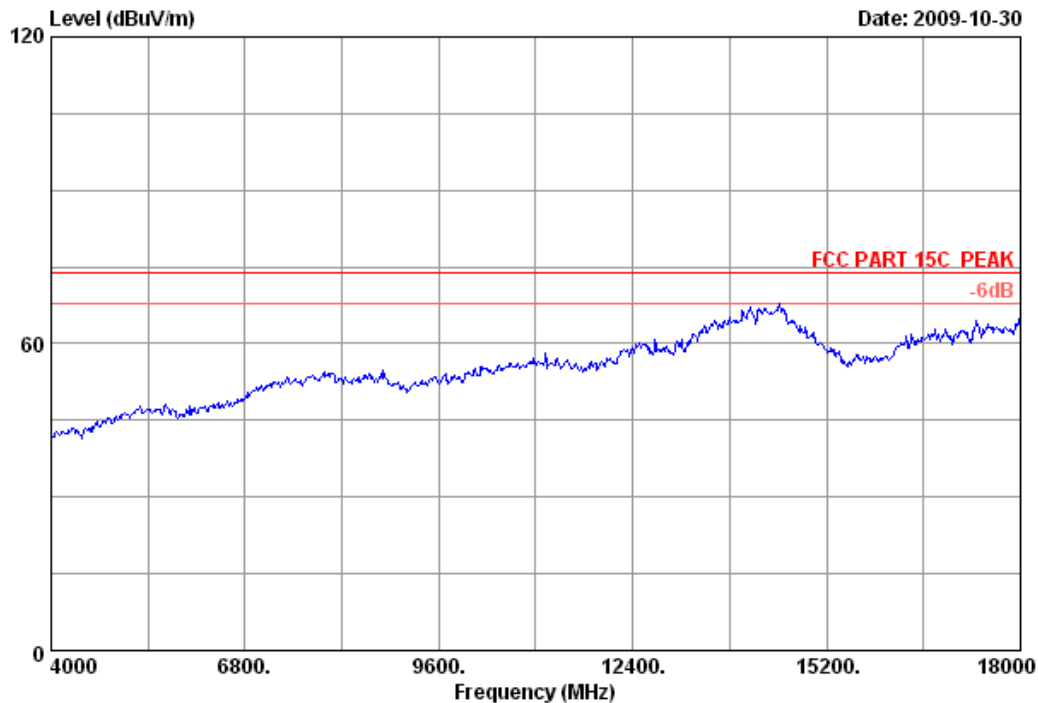

Site no.	: 3m Chamber	Data no.	: 3
Dis. / Ant.	: 3m 3115(0905)	Ant. pol.	: VERTICAL
Limit	: FCC PART 15C PEAK		
Env. / Ins.	: 23°C/54%	Engineer	: Sunny-lu
EUT	: 54M Wireless Router		
Power	: DC 9V From Adapter Input AC 120V/60Hz		
Test mode	: IEEE802.11b CH1 2412MHz Tx		
M/N	: MRO-WR542G		



No.6 Ke Feng Road,Block 52,
ShenZhen Science & Industry Park
Noutou,ShenZhen,GuangDong,China
Tel:+86-755-26639495-7
Fax:+86-755-26632877
Postcode:518057

Data: 4 File: E:\2009 report data\T\TP-LINK\ACS9Q1514.EM6 (56)

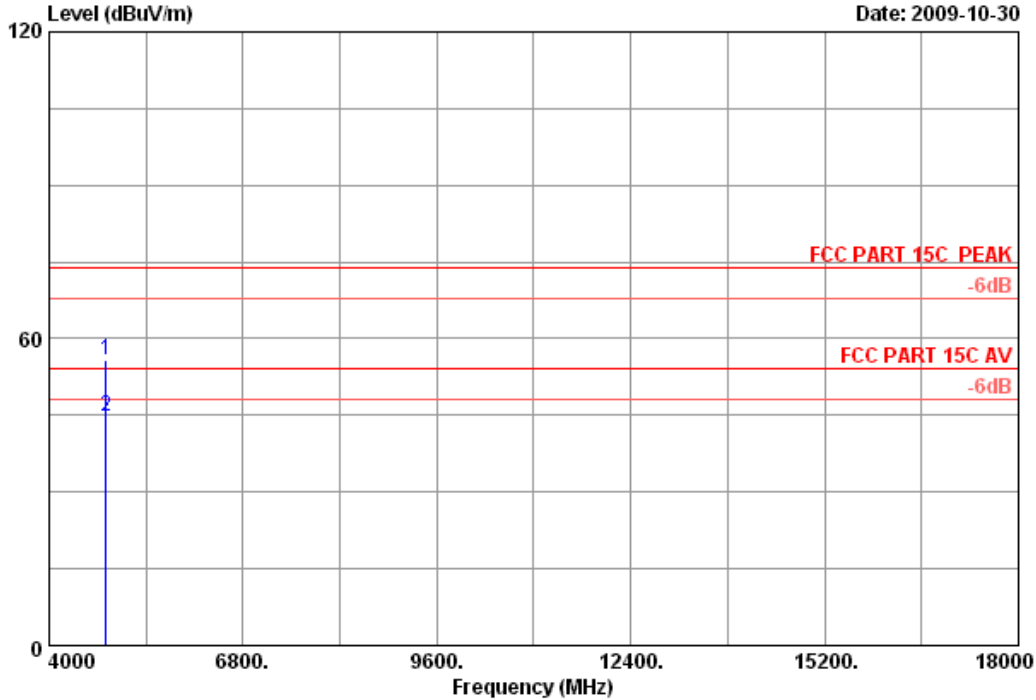

Site no. : 3m Chamber Data no. : 4
 Dis. / Ant. : 3m 3115(0905) Ant. pol. : VERTICAL
 Limit : FCC PART 15C PEAK
 Env. / Ins. : 23*C/54% Engineer : Sunny-lu
 EUT : 54M Wireless Router
 Power : DC 9V From Adapter Input AC 120V/60Hz
 Test mode : IEEE802.11b CH1 2412MHz Tx
 M/N : MRO-WR542G

	Freq. (MHz)	Ant. Factor (dB/m)	Cable loss (dB)	Amp. Factor (dB)	Reading (dbuv)	Emission Level (dBuV/m)	Limits (dBuV/m)	Margin (dB)	Remark
1	4824.000	34.47	12.58	35.25	43.97	55.77	74.00	18.23	Peak
2	4824.000	34.47	12.58	35.25	32.96	44.76	54.00	9.24	Average

Remarks:

1. Emission Level= Antenna Factor + Cable Loss -Amp Factor + Reading.
2. The emission levels that are 20dB below the official limit are not reported.



No.6 Ke Feng Road,Block 52,
ShenZhen Science & Industry Park
Noutou,ShenZhen,GuangDong,China
Tel:+86-755-26639495-7
Fax:+86-755-26632877
Postcode:518057

Data: 5 File: E:\2009 report data\T\TP-LINK\ACS9Q1514.EM6 (56)

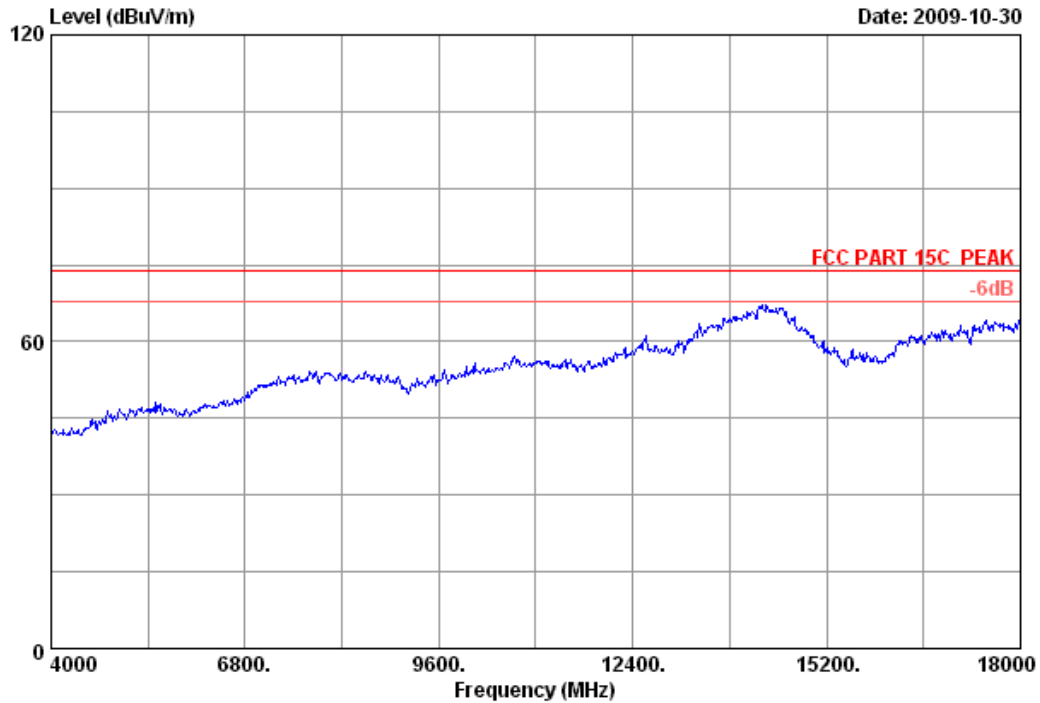

Site no.	: 3m Chamber	Data no.	: 5
Dis. / Ant.	: 3m 3115(0905)	Ant. pol.	: HORIZONTAL
Limit	: FCC PART 15C PEAK		
Env. / Ins.	: 23°C/54%	Engineer	: Sunny-lu
EUT	: 54M Wireless Router		
Power	: DC 9V From Adapter Input AC 120V/60Hz		
Test mode	: IEEE802.11b CH1 2412MHz Tx		
M/N	: MRO-WR542G		



No.6 Ke Feng Road,Block 52,
 ShenZhen Science & Industry Park
 Noutou,ShenZhen,GuangDong,China
 Tel:+86-755-26639495-7
 Fax:+86-755-26632877
 Postcode:518057

Data: 6 File: E:\2009 report data\T\TP-LINK\ACS9Q1514.EM6 (56)

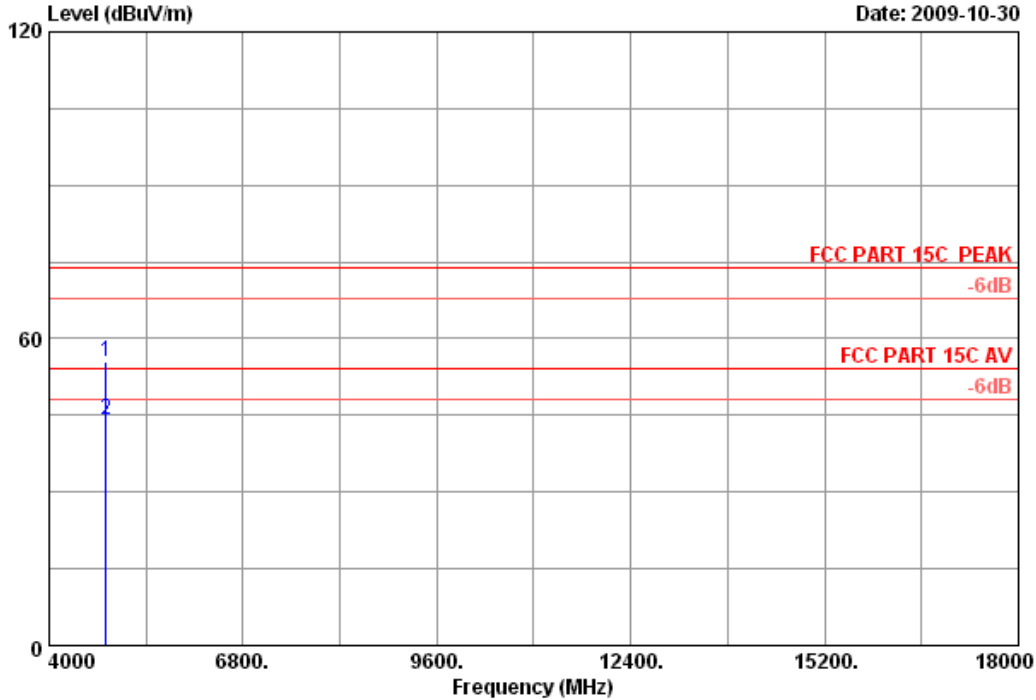

Site no. : 3m Chamber Data no. : 6
 Dis. / Ant. : 3m 3115(0905) Ant. pol. : HORIZONTAL
 Limit : FCC PART 15C PEAK
 Env. / Ins. : 23*C/54% Engineer : Sunny-lu
 EUT : 54M Wireless Router
 Power : DC 9V From Adapter Input AC 120V/60Hz
 Test mode : IEEE802.11b CH1 2412MHz Tx
 M/N : MRO-WR542G

	Ant.	Cable	Amp.	Emission					
Freq.	Factor	loss	Factor	Reading	Level	Limits	Margin	Remark	
(MHz)	(dB/m)	(dB)	(dB)	(dbuv)	(dBuV/m)	(dBuV/m)	(dB)		
1 4824.000	34.47	12.58	35.25	43.57	55.37	74.00	18.63	Peak	
2 4824.000	34.47	12.58	35.25	32.47	44.27	54.00	9.73	Average	

Remarks:

1. Emission Level= Antenna Factor + Cable Loss -Amp Factor + Reading.
2. The emission levels that are 20dB below the official limit are not reported.



No.6 Ke Feng Road,Block 52,
ShenZhen Science & Industry Park
Noutou,ShenZhen,GuangDong,China
Tel:+86-755-26639495-7
Fax:+86-755-26632877
Postcode:518057

Data: 7 File: E:\2009 report data\TP-LINK\ACS9Q1514.EM6 (56)

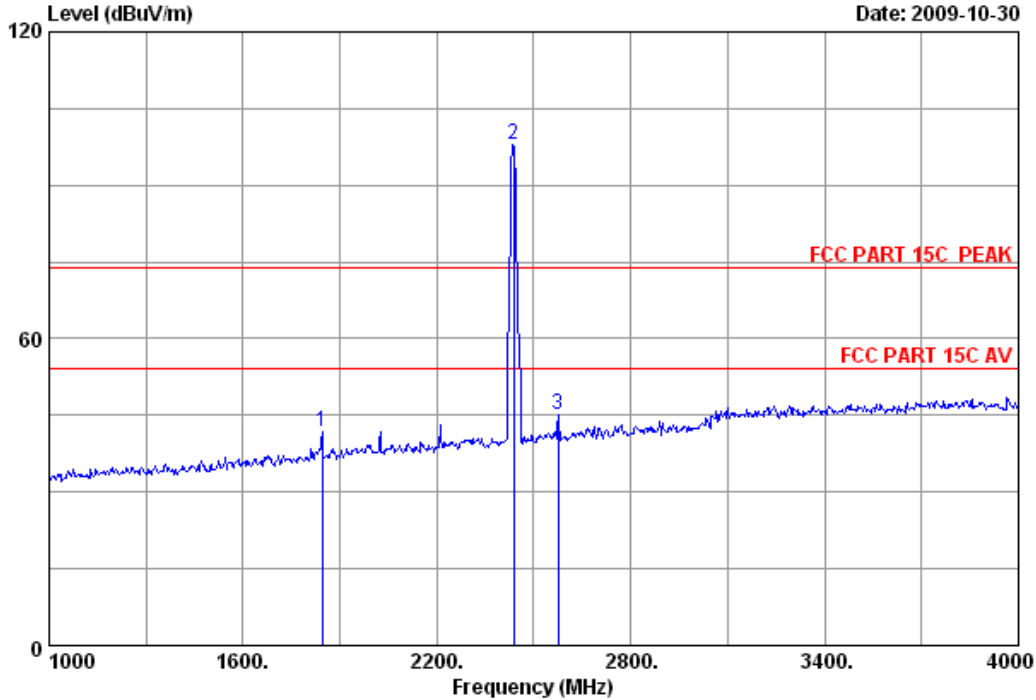

Site no. : 3m Chamber Data no. : 7
 Dis. / Ant. : 3m 3115(0905) Ant. pol. : HORIZONTAL
 Limit : FCC PART 15C PEAK
 Env. / Ins. : 23*C/54% Engineer : Sunny-lu
 EUT : 54M Wireless Router
 Power : DC 9V From Adapter Input AC 120V/60Hz
 Test mode : IEEE802.11b CH6 2437MHz Tx
 M/N : MRO-WR542G

	Freq. (MHz)	Ant. Factor (dB/m)	Cable loss (dB)	Amp. Factor (dB)	Reading (dbuv)	Emission			Remark
						Level (dBuV/m)	Limits (dBuV/m)	Margin (dB)	
1	1846.000	27.30	7.52	36.23	43.21	41.80	74.00	32.20	Peak
2	2437.000	28.53	8.60	36.06	96.97	98.04	74.00	-24.04	Peak
3	2575.000	28.87	9.21	35.78	42.76	45.06	74.00	28.94	Peak

Remarks:

- Emission Level= Antenna Factor + Cable Loss -Amp Factor + Reading.
- The emission levels that are 20dB below the official limit are not reported.



No.6 Ke Feng Road,Block 52,
ShenZhen Science & Industry Park
Noutou,ShenZhen,GuangDong,China
Tel:+86-755-26639495-7
Fax:+86-755-26632877
Postcode:518057

Data: 8 File: E:\2009 report data\TP-LINK\ACS9Q1514.EM6 (56)

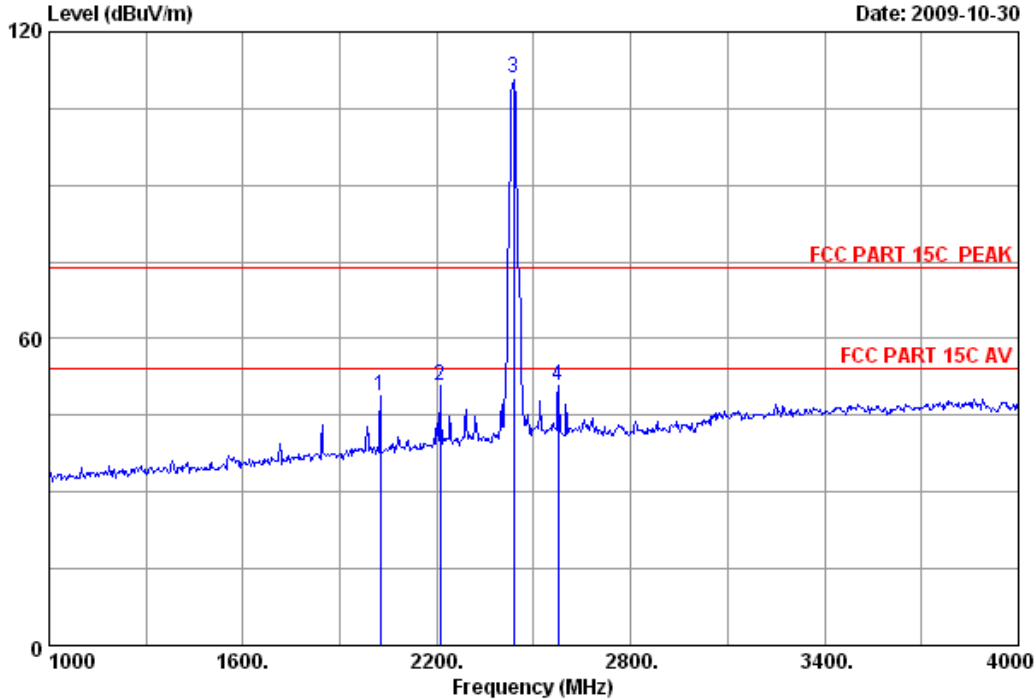

Site no. : 3m Chamber Data no. : 8
 Dis. / Ant. : 3m 3115(0905) Ant. pol. : VERTICAL
 Limit : FCC PART 15C PEAK
 Env. / Ins. : 23°C/54% Engineer : Sunny-lu
 EUT : 54M Wireless Router
 Power : DC 9V From Adapter Input AC 120V/60Hz
 Test mode : IEEE802.11b CH6 2437MHz Tx
 M/N : MRO-WR542G

	Freq. (MHz)	Ant. Factor (dB/m)	Cable loss (dB)	Amp. Factor (dB)	Reading (dbuv)	Emission			Remark
						Level (dBuV/m)	Limits (dBuV/m)	Margin (dB)	
1	2026.000	27.92	7.80	36.12	49.15	48.75	74.00	25.25	Peak
2	2209.000	28.19	8.36	36.02	50.39	50.92	74.00	23.08	Peak
3	2437.000	28.53	8.60	36.06	109.75	110.82	74.00	-36.82	Peak
4	2575.000	28.87	9.21	35.78	48.38	50.68	74.00	23.32	Peak

Remarks:

1. Emission Level= Antenna Factor + Cable Loss -Amp Factor + Reading.
2. The emission levels that are 20dB below the official limit are not reported.



No.6 Ke Feng Road,Block 52,
ShenZhen Science & Industry Park
Noutou,ShenZhen,GuangDong,China
Tel:+86-755-26639495-7
Fax:+86-755-26632877
Postcode:518057

Data: 9 File: E:\2009 report data\T\TP-LINK\ACS9Q1514.EM6 (56)

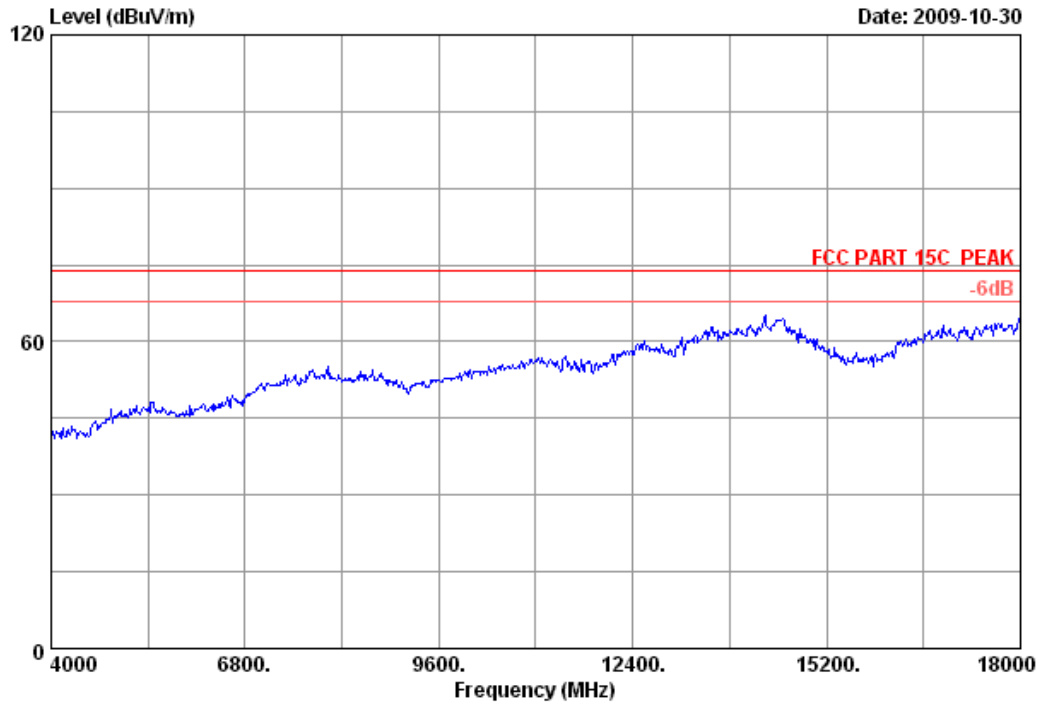

Site no.	: 3m Chamber	Data no.	: 9
Dis. / Ant.	: 3m 3115(0905)	Ant. pol.	: VERTICAL
Limit	: FCC PART 15C PEAK		
Env. / Ins.	: 23°C/54%	Engineer	: Sunny-lu
EUT	: 54M Wireless Router		
Power	: DC 9V From Adapter Input AC 120V/60Hz		
Test mode	: IEEE802.11b CH6 2437MHz Tx		
M/N	: MRO-WR542G		



No.6 Ke Feng Road,Block 52,
 ShenZhen Science & Industry Park
 Noutou,ShenZhen,GuangDong,China
 Tel:+86-755-26639495-7
 Fax:+86-755-26632877
 Postcode:518057

Data: 10 File: E:\2009 report data\TP-LINK\ACS9Q1514.EM6 (56)

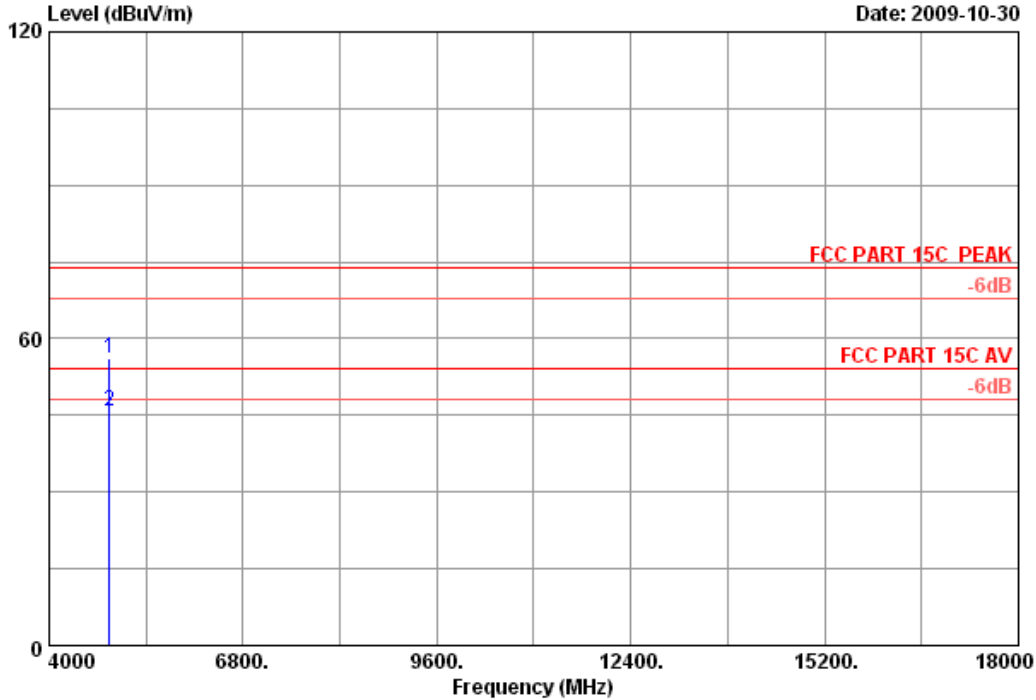

Site no. : 3m Chamber Data no. : 10
 Dis. / Ant. : 3m 3115(0905) Ant. pol. : VERTICAL
 Limit : FCC PART 15C PEAK
 Env. / Ins. : 23°C/54% Engineer : Sunny-lu
 EUT : 54M Wireless Router
 Power : DC 9V From Adapter Input AC 120V/60Hz
 Test mode : IEEE802.11b CH6 2437MHz Tx
 M/N : MRO-WR542G

	Freq. (MHz)	Ant. Factor (dB/m)	Cable loss (dB)	Amp. Factor (dB)	Reading (dbuv)	Emission Level (dBuV/m)	Limits (dBuV/m)	Margin (dB)	Remark
1	4874.000	34.78	12.23	35.36	44.58	56.23	74.00	17.77	Peak
2	4874.000	34.78	12.23	35.36	34.26	45.91	54.00	8.09	Average

Remarks:

1. Emission Level= Antenna Factor + Cable Loss -Amp Factor + Reading.
2. The emission levels that are 20dB below the official limit are not reported.



No.6 Ke Feng Road,Block 52,
ShenZhen Science & Industry Park
Noutou,ShenZhen,GuangDong,China
Tel:+86-755-26639495-7
Fax:+86-755-26632877
Postcode:518057

Data: 11 File: E:\2009 report data\T\TP-LINK\ACS9Q1514.EM6 (56)

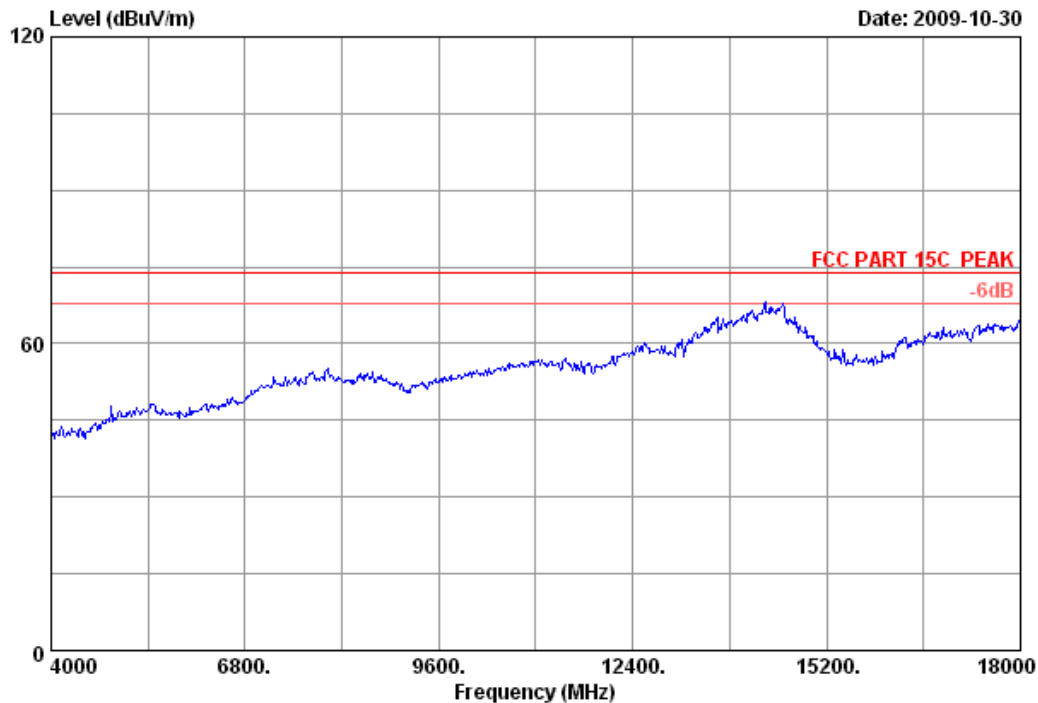

Site no.	: 3m Chamber	Data no.	: 11
Dis. / Ant.	: 3m 3115(0905)	Ant. pol.	: HORIZONTAL
Limit	: FCC PART 15C PEAK		
Env. / Ins.	: 23°C/54%	Engineer	: Sunny-lu
EUT	: 54M Wireless Router		
Power	: DC 9V From Adapter Input AC 120V/60Hz		
Test mode	: IEEE802.11b CH6 2437MHz Tx		
M/N	: MRO-WR542G		



No.6 Ke Feng Road,Block 52,
 ShenZhen Science & Industry Park
 Noutou,ShenZhen,GuangDong,China
 Tel:+86-755-26639495-7
 Fax:+86-755-26632877
 Postcode:518057

Data: 12 File: E:\2009 report data\TP-LINK\ACS9Q1514.EM6 (56)

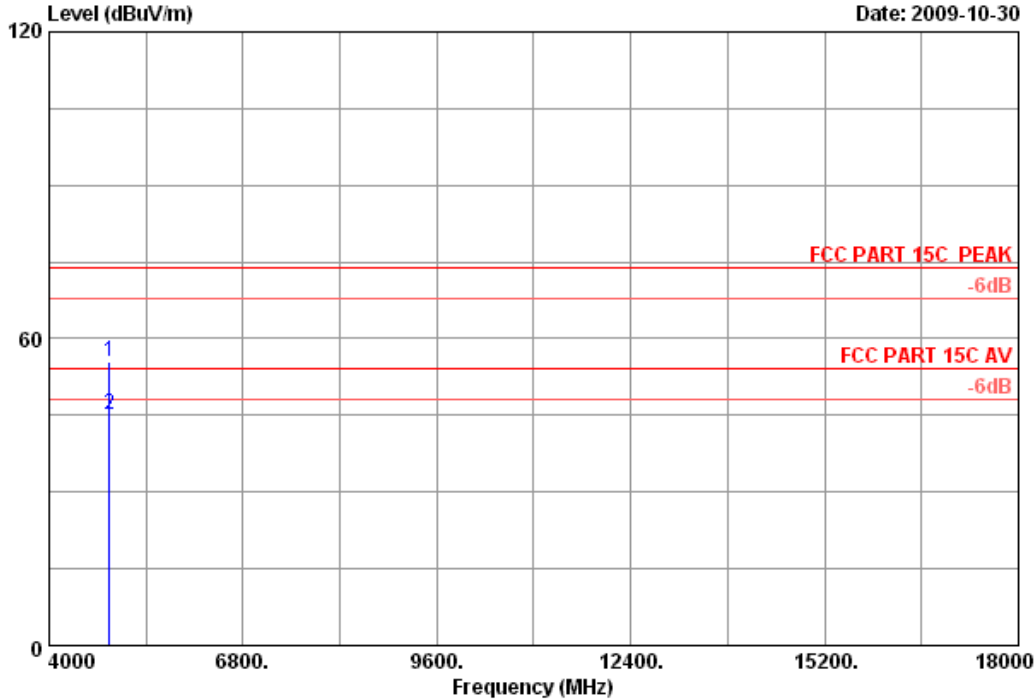

Site no. : 3m Chamber Data no. : 12
 Dis. / Ant. : 3m 3115(0905) Ant. pol. : HORIZONTAL
 Limit : FCC PART 15C PEAK
 Env. / Ins. : 23°C/54% Engineer : Sunny-lu
 EUT : 54M Wireless Router
 Power : DC 9V From Adapter Input AC 120V/60Hz
 Test mode : IEEE802.11b CH6 2437MHz Tx
 M/N : MRO-WR542G

	Ant. Factor (dB/m)	Cable loss (dB)	Amp. Factor (dB)	Reading (dbuv)	Emission Level (dBuV/m)	Limits (dBuV/m)	Margin (dB)	Remark
1	34.78	12.23	35.36	43.94	55.59	74.00	18.41	Peak
2	34.78	12.23	35.36	33.47	45.12	54.00	8.88	Average

Remarks:
 1. Emission Level= Antenna Factor + Cable Loss -Amp Factor + Reading.
 2. The emission levels that are 20dB below the official limit are not reported.



No.6 Ke Feng Road,Block 52,
 ShenZhen Science & Industry Park
 Noutou,ShenZhen,GuangDong,China
 Tel:+86-755-26639495-7
 Fax:+86-755-26632877
 Postcode:518057

Data: 13 File: E:\2009 report data\TP-LINK\ACS9Q1514.EM6 (56)

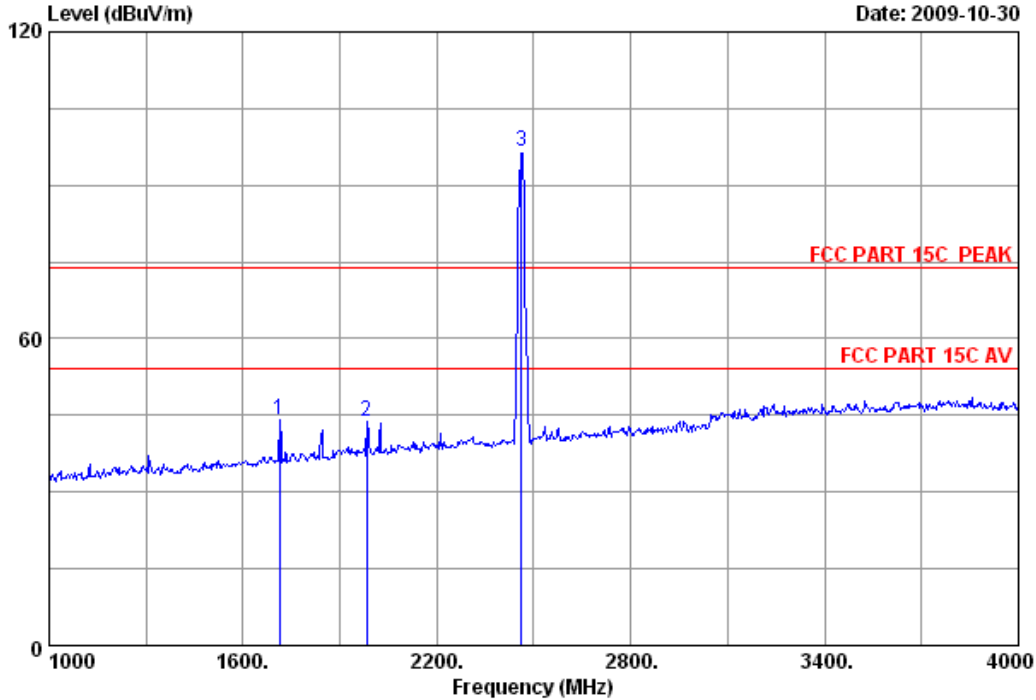

Site no. : 3m Chamber Data no. : 13
 Dis. / Ant. : 3m 3115(0905) Ant. pol. : HORIZONTAL
 Limit : FCC PART 15C PEAK
 Env. / Ins. : 23°C/54% Engineer : Sunny-lu
 EUT : 54M Wireless Router
 Power : DC 9V From Adapter Input AC 120V/60Hz
 Test mode : IEEE802.11b CH11 2462MHz Tx
 M/N : MRO-WR542G

	Freq. (MHz)	Ant. Factor (dB/m)	Cable loss (dB)	Amp. Factor (dB)	Reading (dbuv)	Emission			Remark
						Level (dBuV/m)	Limits (dBuV/m)	Margin (dB)	
1	1714.000	26.77	7.27	36.30	46.41	44.15	74.00	29.85	Peak
2	1984.000	27.83	7.76	36.06	44.20	43.73	74.00	30.27	Peak
3	2462.000	28.55	8.76	36.02	95.17	96.46	74.00	-22.46	Peak

Remarks:

1. Emission Level= Antenna Factor + Cable Loss -Amp Factor + Reading.
2. The emission levels that are 20dB below the official limit are not reported.



No.6 Ke Feng Road,Block 52,
 ShenZhen Science & Industry Park
 Noutou,ShenZhen,GuangDong,China
 Tel:+86-755-26639495-7
 Fax:+86-755-26632877
 Postcode:518057

Data: 14 File: E:\2009 report data\TP-LINK\ACS9Q1514.EM6 (56)

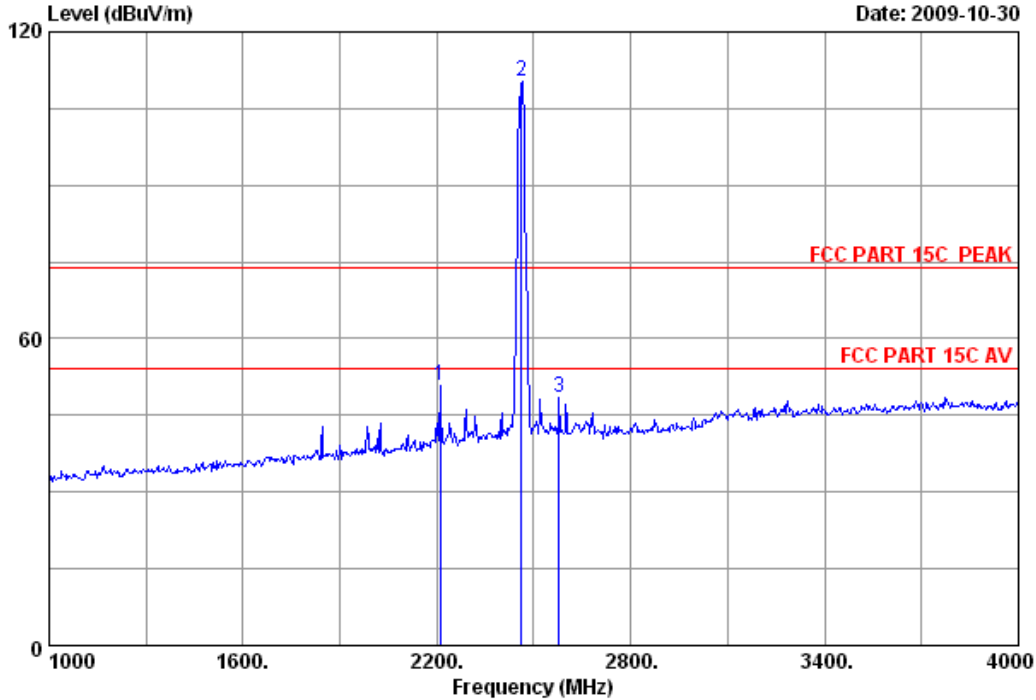

Site no. : 3m Chamber Data no. : 14
 Dis. / Ant. : 3m 3115(0905) Ant. pol. : VERTICAL
 Limit : FCC PART 15C PEAK
 Env. / Ins. : 23°C/54% Engineer : Sunny-lu
 EUT : 54M Wireless Router
 Power : DC 9V From Adapter Input AC 120V/60Hz
 Test mode : IEEE802.11b CH11 2462MHz Tx
 M/N : MRO-WR542G

	Ant. Factor (dB/m)	Cable loss (dB)	Amp. Factor (dB)	Reading (dbuv)	Emission Level (dBuV/m)	Limits (dBuV/m)	Margin (dB)	Remark
1	28.19	8.36	36.02	50.30	50.83	74.00	23.17	Peak
2	28.55	8.76	36.02	108.88	110.17	74.00	-36.17	Peak
3	28.87	9.21	35.78	46.03	48.33	74.00	25.67	Peak

Remarks:

1. Emission Level= Antenna Factor + Cable Loss -Amp Factor + Reading.
2. The emission levels that are 20dB below the official limit are not reported.



No.6 Ke Feng Road,Block 52,
ShenZhen Science & Industry Park
Noutou,ShenZhen,GuangDong,China
Tel:+86-755-26639495-7
Fax:+86-755-26632877
Postcode:518057

Data: 15 File: E:\2009 report data\T\TP-LINK\ACS9Q1514.EM6 (56)

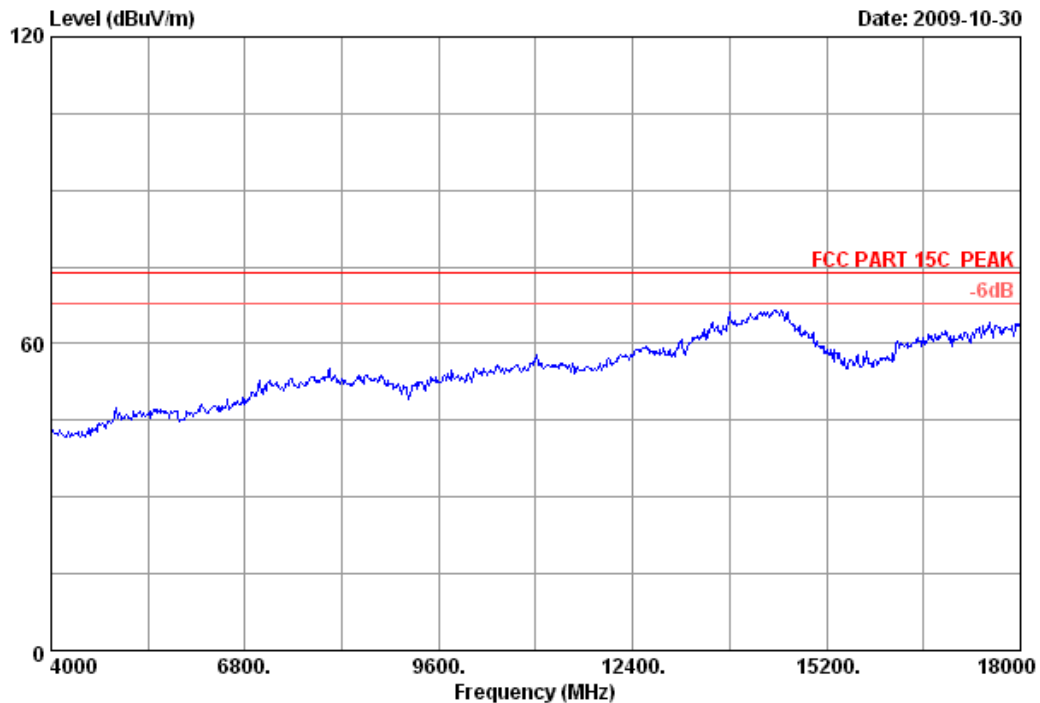

Site no.	: 3m Chamber	Data no.	: 15
Dis. / Ant.	: 3m 3115(0905)	Ant. pol.	: HORIZONTAL
Limit	: FCC PART 15C PEAK		
Env. / Ins.	: 23°C/54%	Engineer	: Sunny-lu
EUT	: 54M Wireless Router		
Power	: DC 9V From Adapter Input AC 120V/60Hz		
Test mode	: IEEE802.11b CH11 2462MHz Tx		
M/N	: MRO-WR542G		



No.6 Ke Feng Road,Block 52,
 ShenZhen Science & Industry Park
 Noutou,ShenZhen,GuangDong,China
 Tel:+86-755-26639495-7
 Fax:+86-755-26632877
 Postcode:518057

Data: 16 File: E:\2009 report data\TP-LINK\ACS9Q1514.EM6 (56)

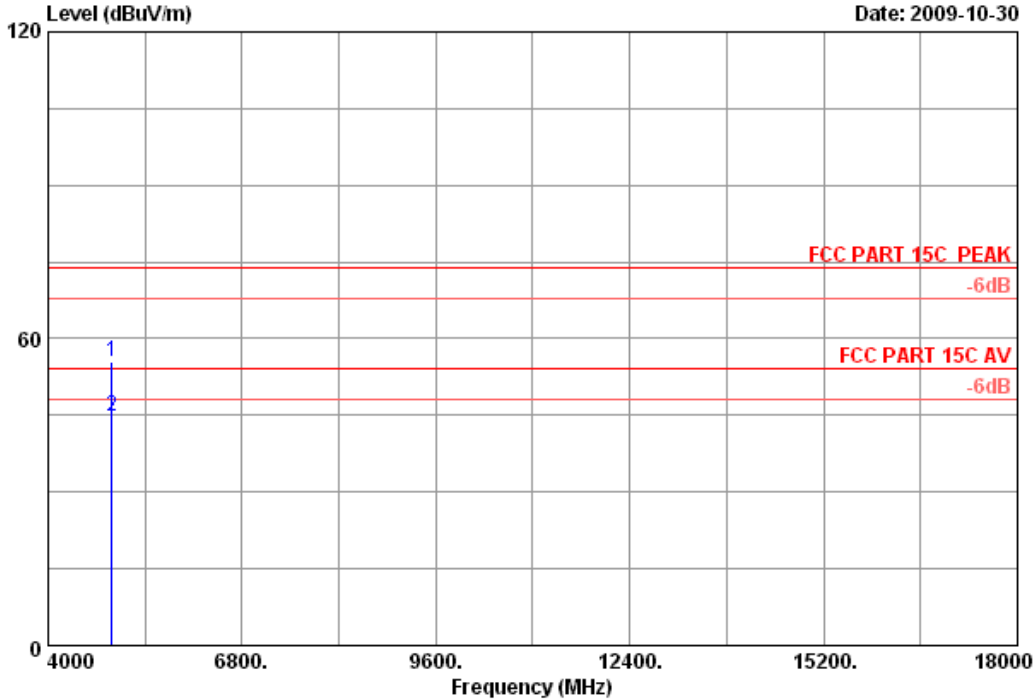

Site no. : 3m Chamber Data no. : 16
 Dis. / Ant. : 3m 3115(0905) Ant. pol. : HORIZONTAL
 Limit : FCC PART 15C PEAK
 Env. / Ins. : 23°C/54% Engineer : Sunny-lu
 EUT : 54M Wireless Router
 Power : DC 9V From Adapter Input AC 120V/60Hz
 Test mode : IEEE802.11b CH11 2462MHz Tx
 M/N : MRO-WR542G

	Freq. (MHz)	Ant. Factor (dB/m)	Cable loss (dB)	Amp. Factor (dB)	Reading (dbuv)	Emission Level (dBuV/m)	Limits (dBuV/m)	Margin (dB)	Remark
1	4924.000	35.09	12.58	35.34	43.24	55.57	74.00	18.43	Peak
2	4924.000	35.09	12.58	35.34	32.45	44.78	54.00	9.22	Average

Remarks:
 1. Emission Level= Antenna Factor + Cable Loss -Amp Factor + Reading.
 2. The emission levels that are 20dB below the official limit are not reported.



No.6 Ke Feng Road,Block 52,
ShenZhen Science & Industry Park
Noutou,ShenZhen,GuangDong,China
Tel:+86-755-26639495-7
Fax:+86-755-26632877
Postcode:518057

Data: 17 File: E:\2009 report data\T\TP-LINK\ACS9Q1514.EM6 (56)

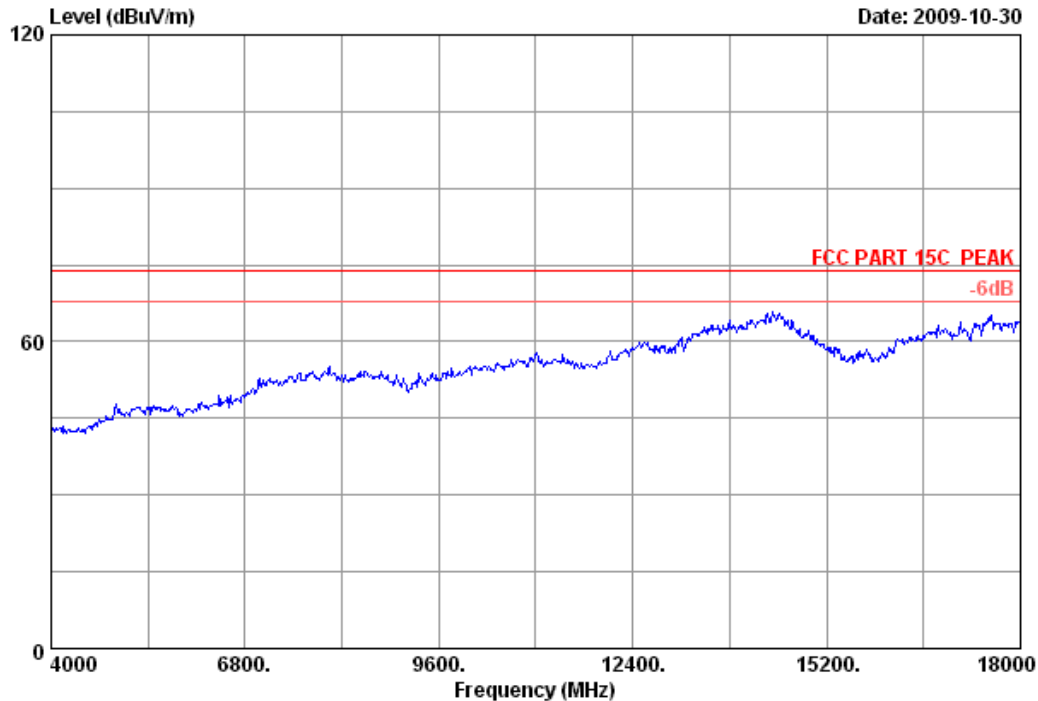

Site no.	: 3m Chamber	Data no.	: 17
Dis. / Ant.	: 3m 3115(0905)	Ant. pol.	: VERTICAL
Limit	: FCC PART 15C PEAK		
Env. / Ins.	: 23°C/54%	Engineer	: Sunny-lu
EUT	: 54M Wireless Router		
Power	: DC 9V From Adapter Input AC 120V/60Hz		
Test mode	: IEEE802.11b CH11 2462MHz Tx		
M/N	: MRO-WR542G		



No.6 Ke Feng Road,Block 52,
 ShenZhen Science & Industry Park
 Noutou,ShenZhen,GuangDong,China
 Tel:+86-755-26639495-7
 Fax:+86-755-26632877
 Postcode:518057

Data: 18 File: E:\2009 report data\T\TP-LINK\ACS9Q1514.EM6 (56)

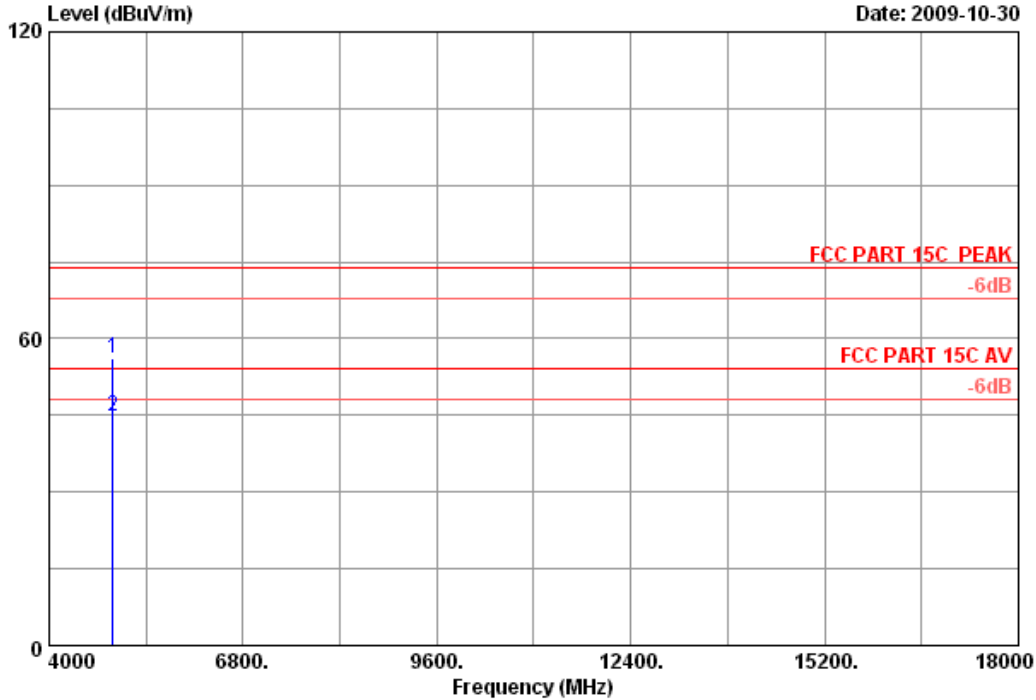

Site no. : 3m Chamber Data no. : 18
 Dis. / Ant. : 3m 3115(0905) Ant. pol. : VERTICAL
 Limit : FCC PART 15C PEAK
 Env. / Ins. : 23*C/54% Engineer : Sunny-lu
 EUT : 54M Wireless Router
 Power : DC 9V From Adapter Input AC 120V/60Hz
 Test mode : IEEE802.11b CH11 2462MHz Tx
 M/N : MRO-WR542G

	Freq. (MHz)	Ant. Factor (dB/m)	Cable loss (dB)	Amp. Factor (dB)	Reading (dbuv)	Emission Level (dBuV/m)	Limits (dBuV/m)	Margin (dB)	Remark
1	4924.000	35.09	12.58	35.34	43.96	56.29	74.00	17.71	Peak
2	4924.000	35.09	12.58	35.34	32.47	44.80	54.00	9.20	Average

Remarks:
 1. Emission Level= Antenna Factor + Cable Loss -Amp Factor + Reading.
 2. The emission levels that are 20dB below the official limit are not reported.



No.6 Ke Feng Road,Block 52,
 ShenZhen Science & Industry Park
 Noutou,ShenZhen,GuangDong,China
 Tel:+86-755-26639495-7
 Fax:+86-755-26632877
 Postcode:518057

Data: 19 File: E:\2009 report data\TP-LINK\ACS9Q1514.EM6 (56)

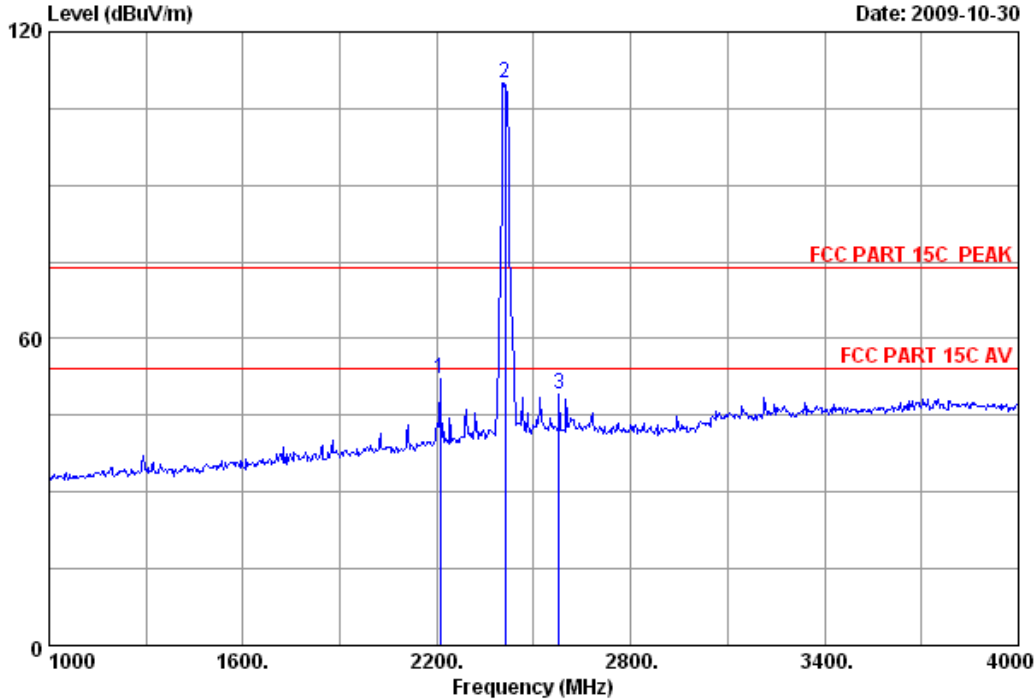

Site no. : 3m Chamber Data no. : 19
 Dis. / Ant. : 3m 3115(0905) Ant. pol. : VERTICAL
 Limit : FCC PART 15C PEAK
 Env. / Ins. : 23°C/54% Engineer : Sunny-lu
 EUT : 54M Wireless Router
 Power : DC 9V From Adapter Input AC 120V/60Hz
 Test mode : IEEE802.11g CH1 2412MHz Tx
 M/N : MRO-WR542G

	Ant. Factor (dB/m)	Cable loss (dB)	Amp. Factor (dB)	Reading (dbuv)	Emission Level (dBuV/m)	Limits (dBuV/m)	Margin (dB)	Remark
1	28.19	8.36	36.02	51.75	52.28	74.00	21.72	Peak
2	28.48	8.60	35.95	108.96	110.09	74.00	-36.09	Peak
3	28.87	9.21	35.78	46.80	49.10	74.00	24.90	Peak

Remarks:

1. Emission Level= Antenna Factor + Cable Loss -Amp Factor + Reading.
2. The emission levels that are 20dB below the official limit are not reported.



No.6 Ke Feng Road,Block 52,
 ShenZhen Science & Industry Park
 Noutou,ShenZhen,GuangDong,China
 Tel:+86-755-26639495-7
 Fax:+86-755-26632877
 Postcode:518057

Data: 20 File: E:\2009 report data\TP-LINK\ACS9Q1514.EM6 (56)

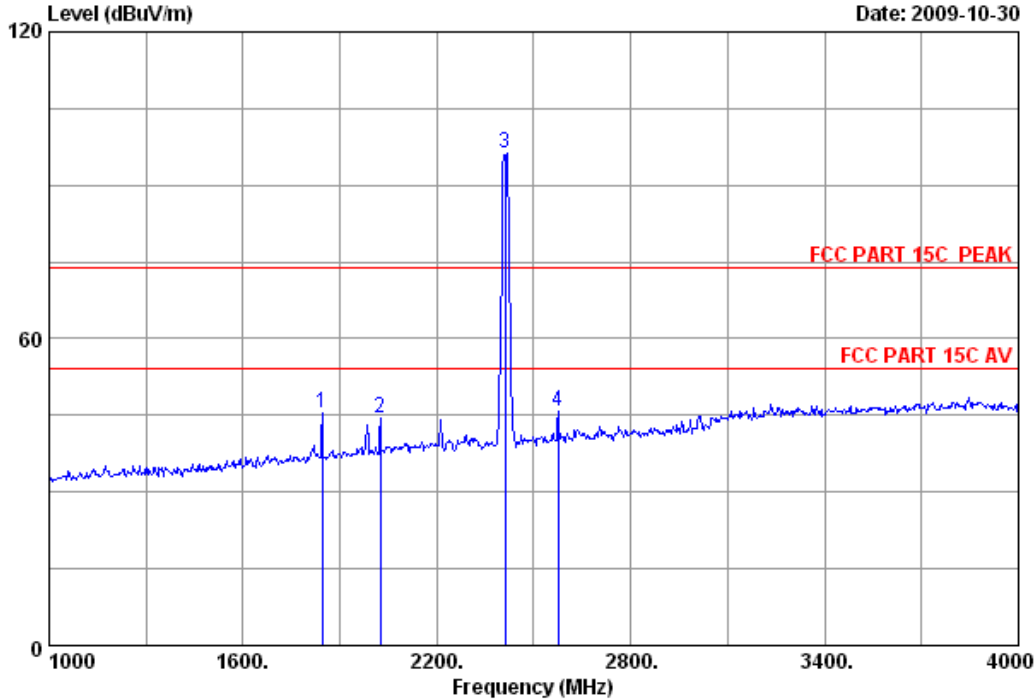

Site no. : 3m Chamber Data no. : 20
 Dis. / Ant. : 3m 3115(0905) Ant. pol. : HORIZONTAL
 Limit : FCC PART 15C PEAK
 Env. / Ins. : 23°C/54% Engineer : Sunny-lu
 EUT : 54M Wireless Router
 Power : DC 9V From Adapter Input AC 120V/60Hz
 Test mode : IEEE802.11g CH1 2412MHz Tx
 M/N : MRO-WR542G

	Freq. (MHz)	Ant. Factor (dB/m)	Cable loss (dB)	Amp. Factor (dB)	Reading (dbuv)	Emission			Remark
						Level (dBuV/m)	Limits (dBuV/m)	Margin (dB)	
1	1846.000	27.30	7.52	36.23	46.84	45.43	74.00	28.57	Peak
2	2026.000	27.92	7.80	36.12	44.75	44.35	74.00	29.65	Peak
3	2412.000	28.48	8.60	35.95	94.99	96.12	74.00	-22.12	Peak
4	2575.000	28.87	9.21	35.78	43.41	45.71	74.00	28.29	Peak

Remarks:

1. Emission Level= Antenna Factor + Cable Loss -Amp Factor + Reading.
2. The emission levels that are 20dB below the official limit are not reported.



No.6 Ke Feng Road,Block 52,
ShenZhen Science & Industry Park
Noutou,ShenZhen,GuangDong,China
Tel:+86-755-26639495-7
Fax:+86-755-26632877
Postcode:518057

Data: 21 File: E:\2009 report data\T\TP-LINK\ACS9Q1514.EM6 (56)

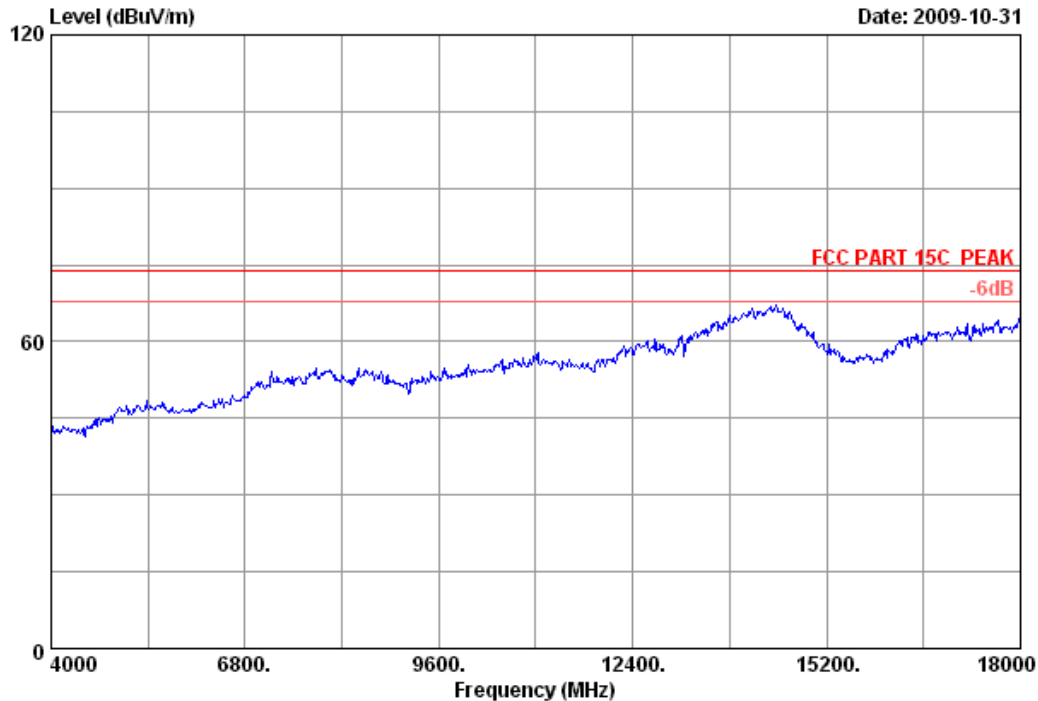

Site no.	: 3m Chamber	Data no.	: 21
Dis. / Ant.	: 3m 3115(0905)	Ant. pol.	: VERTICAL
Limit	: FCC PART 15C PEAK		
Env. / Ins.	: 23°C/54%	Engineer	: Sunny-lu
EUT	: 54M Wireless Router		
Power	: DC 9V From Adapter Input AC 120V/60Hz		
Test mode	: IEEE802.11g CH1 2412MHz Tx		
M/N	: MRO-WR542G		



No.6 Ke Feng Road,Block 52,
 ShenZhen Science & Industry Park
 Noutou,ShenZhen,GuangDong,China
 Tel:+86-755-26639495-7
 Fax:+86-755-26632877
 Postcode:518057

Data: 22 File: E:\2009 report data\TP-LINK\ACS9Q1514.EM6 (56)

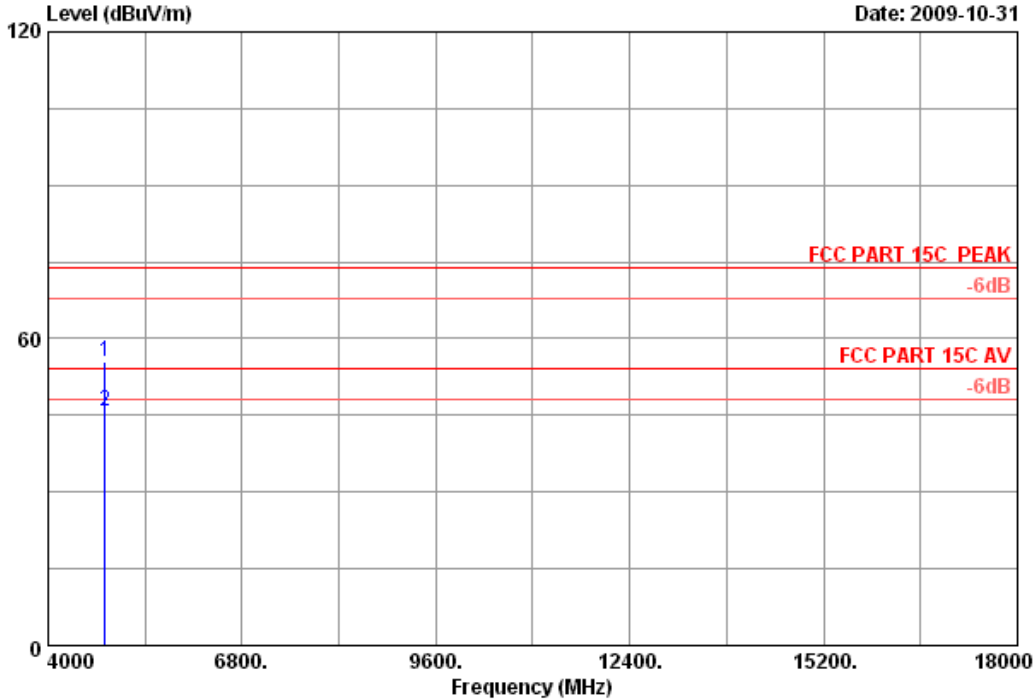

Site no. : 3m Chamber Data no. : 22
 Dis. / Ant. : 3m 3115(0905) Ant. pol. : VERTICAL
 Limit : FCC PART 15C PEAK
 Env. / Ins. : 23*C/54% Engineer : Sunny-lu
 EUT : 54M Wireless Router
 Power : DC 9V From Adapter Input AC 120V/60Hz
 Test mode : IEEE802.11g CH1 2412MHz Tx
 M/N : MRO-WR542G

	Freq. (MHz)	Ant. Factor (dB/m)	Cable loss (dB)	Amp. Factor (dB)	Reading (dbuv)	Emission Level (dBuV/m)	Limits (dBuV/m)	Margin (dB)	Remark
1	4824.000	34.47	12.58	35.25	43.68	55.48	74.00	18.52	Peak
2	4824.000	34.47	12.58	35.25	33.88	45.68	54.00	8.32	Average

Remarks:

1. Emission Level= Antenna Factor + Cable Loss -Amp Factor + Reading.
2. The emission levels that are 20dB below the official limit are not reported.



No.6 Ke Feng Road,Block 52,
 ShenZhen Science & Industry Park
 Noutou,ShenZhen,GuangDong,China
 Tel:+86-755-26639495-7
 Fax:+86-755-26632877
 Postcode:518057

Data: 23 File: E:\2009 report data\T\TP-LINK\ACS9Q1514.EM6 (56)

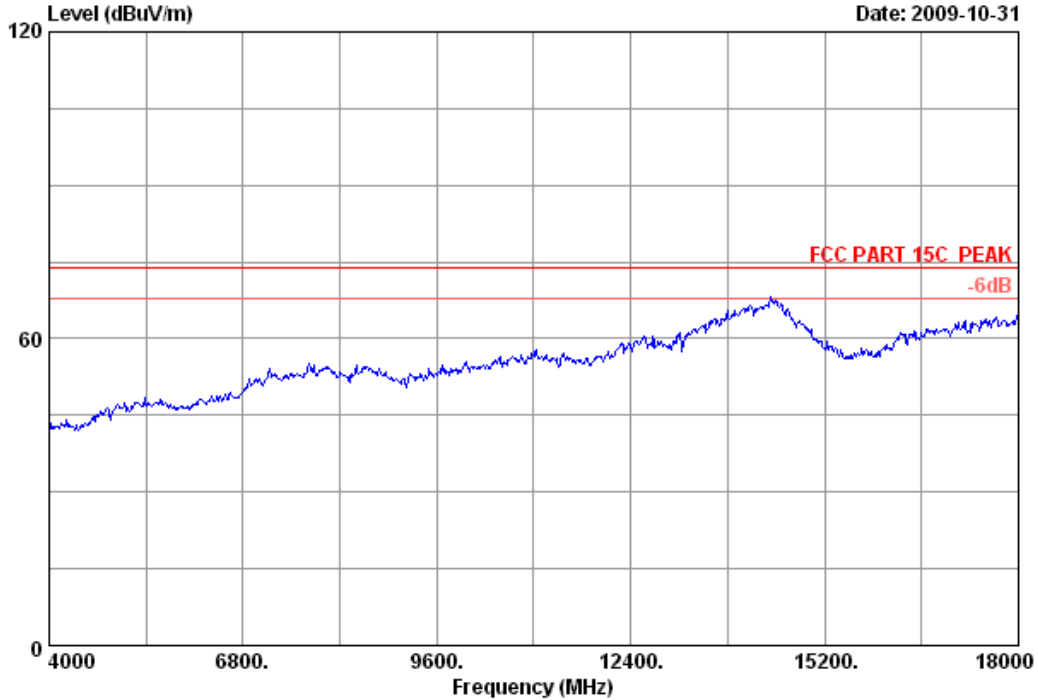

Site no.	: 3m Chamber	Data no.	: 23
Dis. / Ant.	: 3m 3115(0905)	Ant. pol.	: HORIZONTAL
Limit	: FCC PART 15C PEAK		
Env. / Ins.	: 23°C/54%	Engineer	: Sunny-lu
EUT	: 54M Wireless Router		
Power	: DC 9V From Adapter Input AC 120V/60Hz		
Test mode	: IEEE802.11g CH1 2412MHz Tx		
M/N	: MRO-WR542G		



No.6 Ke Feng Road,Block 52,
ShenZhen Science & Industry Park
Noutou,ShenZhen,GuangDong,China
Tel:+86-755-26639495-7
Fax:+86-755-26632877
Postcode:518057

Data: 24 File: E:\2009 report data\TP-LINK\ACS9Q1514.EM6 (56)

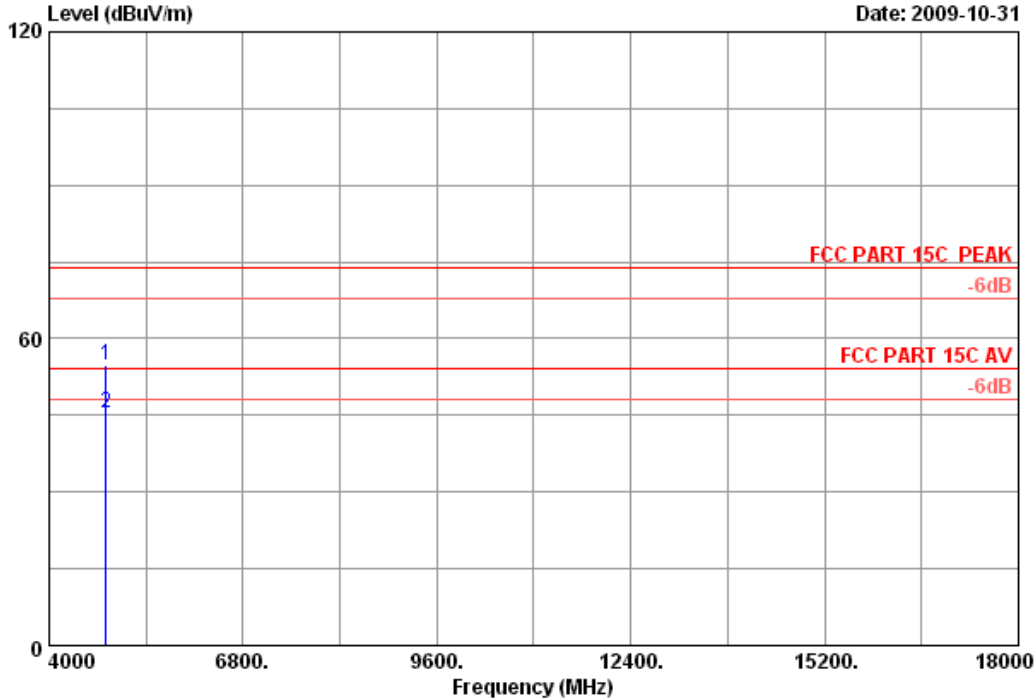

Site no. : 3m Chamber Data no. : 24
 Dis. / Ant. : 3m 3115(0905) Ant. pol. : HORIZONTAL
 Limit : FCC PART 15C PEAK
 Env. / Ins. : 23°C/54% Engineer : Sunny-lu
 EUT : 54M Wireless Router
 Power : DC 9V From Adapter Input AC 120V/60Hz
 Test mode : IEEE802.11g CH1 2412MHz Tx
 M/N : MRO-WR542G

	Ant. Factor (dB/m)	Cable loss (dB)	Amp. Factor (dB)	Reading (dbuv)	Emission Level (dBuV/m)	Emission Limits (dBuV/m)	Margin (dB)	Remark
1	34.47	12.58	35.25	43.00	54.80	74.00	19.20	Peak
2	34.47	12.58	35.25	33.56	45.36	54.00	8.64	Average

- Remarks:
1. Emission Level= Antenna Factor + Cable Loss -Amp Factor + Reading.
 2. The emission levels that are 20dB below the official limit are not reported.



No.6 Ke Feng Road,Block 52,
 ShenZhen Science & Industry Park
 Noutou,ShenZhen,GuangDong,China
 Tel:+86-755-26639495-7
 Fax:+86-755-26632877
 Postcode:518057

Data: 25 File: E:\2009 report data\TP-LINK\ACS9Q1514.EM6 (56)

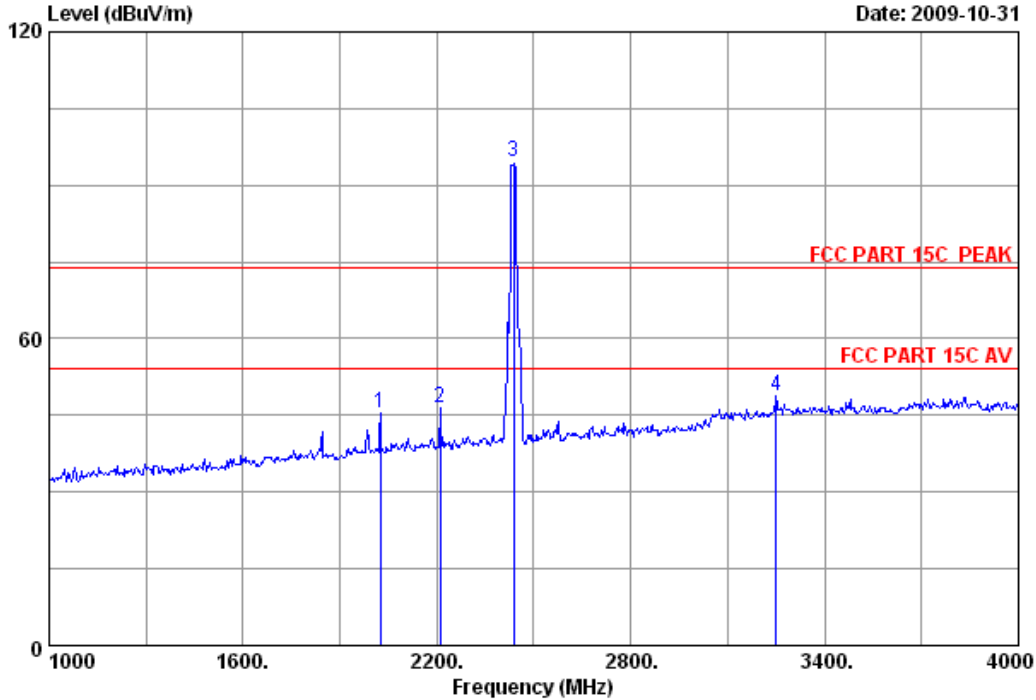

Site no. : 3m Chamber Data no. : 25
 Dis. / Ant. : 3m 3115(0905) Ant. pol. : HORIZONTAL
 Limit : FCC PART 15C PEAK
 Env. / Ins. : 23°C/54% Engineer : Sunny-lu
 EUT : 54M Wireless Router
 Power : DC 9V From Adapter Input AC 120V/60Hz
 Test mode : IEEE802.11g CH6 2437MHz Tx
 M/N : MRO-WR542G

	Freq. (MHz)	Ant. Factor (dB/m)	Cable loss (dB)	Amp. Factor (dB)	Reading (dbuv)	Emission			Remark
						Level (dBuV/m)	Limits (dBuV/m)	Margin (dB)	
1	2026.000	27.92	7.80	36.12	45.71	45.31	74.00	28.69	Peak
2	2209.000	28.19	8.36	36.02	45.80	46.33	74.00	27.67	Peak
3	2437.000	28.53	8.60	36.06	93.57	94.64	74.00	-20.64	Peak
4	3250.000	30.88	10.19	35.68	43.38	48.77	74.00	25.23	Peak

Remarks:

1. Emission Level= Antenna Factor + Cable Loss -Amp Factor + Reading.
2. The emission levels that are 20dB below the official limit are not reported.



No.6 Ke Feng Road,Block 52,
 ShenZhen Science & Industry Park
 Noutou,ShenZhen,GuangDong,China
 Tel:+86-755-26639495-7
 Fax:+86-755-26632877
 Postcode:518057

Data: 26 File: E:\2009 report data\TP-LINK\ACS9Q1514.EM6 (56)

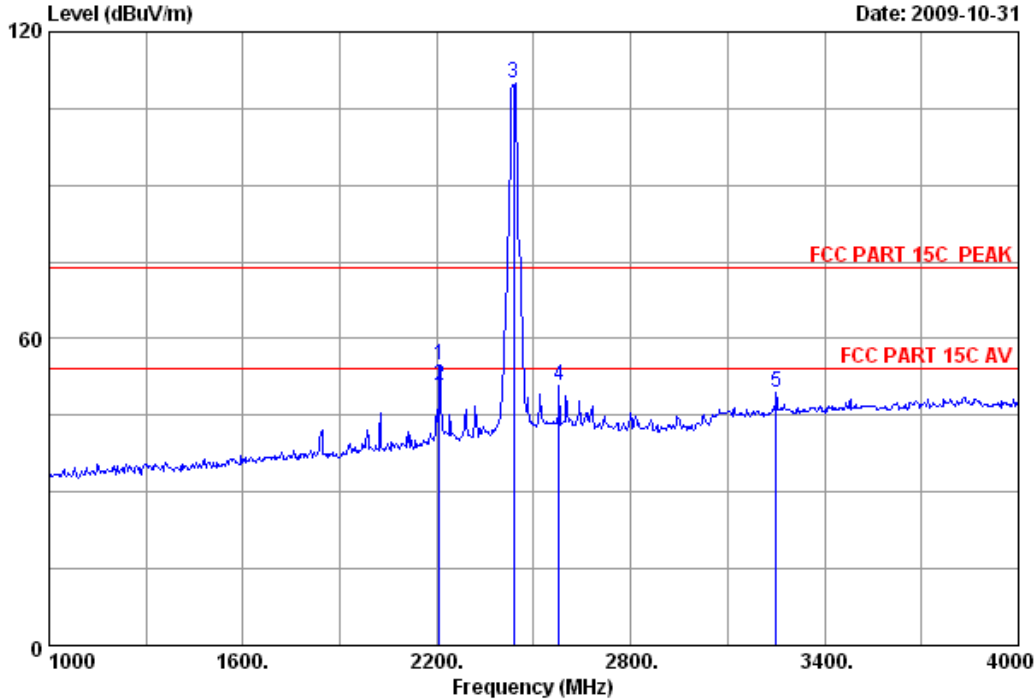

Site no. : 3m Chamber Data no. : 26
 Dis. / Ant. : 3m 3115(0905) Ant. pol. : VERTICAL
 Limit : FCC PART 15C PEAK
 Env. / Ins. : 23*C/54% Engineer : Sunny-lu
 EUT : 54M Wireless Router
 Power : DC 9V From Adapter Input AC 120V/60Hz
 Test mode : IEEE802.11g CH6 2437MHz Tx
 M/N : MRO-WR542G

	Freq. (MHz)	Ant. Factor (dB/m)	Cable loss (dB)	Amp. Factor (dB)	Reading (dbuv)	Emission			Remark
						Level (dBuV/m)	Limits (dBuV/m)	Margin (dB)	
1	2208.000	28.19	8.36	36.02	54.35	54.88	74.00	19.12	Peak
2	2208.000	28.19	8.36	36.02	50.16	50.69	54.00	3.31	Average
3	2437.000	28.53	8.60	36.06	108.76	109.83	74.00	-35.83	Peak
4	2578.000	28.87	9.21	35.78	48.49	50.79	74.00	23.21	Peak
5	3250.000	30.88	10.19	35.68	44.14	49.53	74.00	24.47	Peak

Remarks:

1. Emission Level= Antenna Factor + Cable Loss -Amp Factor + Reading.
2. The emission levels that are 20dB below the official limit are not reported.



No.6 Ke Feng Road,Block 52,
ShenZhen Science & Industry Park
Noutou,ShenZhen,GuangDong,China
Tel:+86-755-26639495-7
Fax:+86-755-26632877
Postcode:518057

Data: 27 File: E:\2009 report data\T\TP-LINK\ACS9Q1514.EM6 (56)

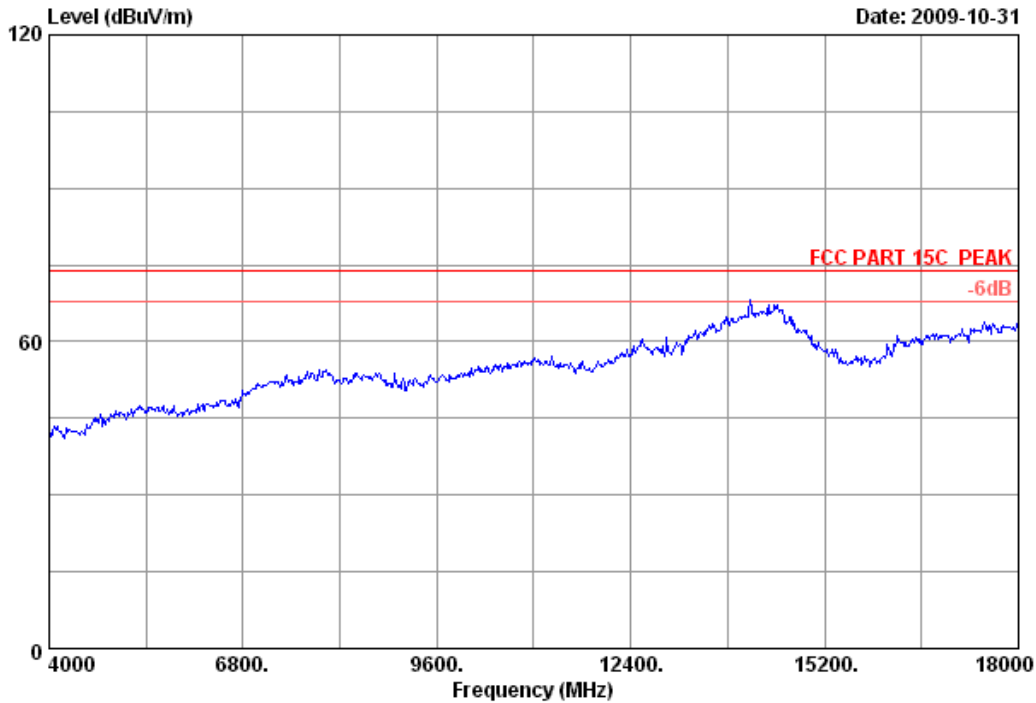

Site no.	: 3m Chamber	Data no.	: 27
Dis. / Ant.	: 3m 3115(0905)	Ant. pol.	: VERTICAL
Limit	: FCC PART 15C PEAK		
Env. / Ins.	: 23°C/54%	Engineer	: Sunny-lu
EUT	: 54M Wireless Router		
Power	: DC 9V From Adapter Input AC 120V/60Hz		
Test mode	: IEEE802.11g CH6 2437MHz Tx		
M/N	: MRO-WR542G		



No.6 Ke Feng Road,Block 52,
 ShenZhen Science & Industry Park
 Noutou,ShenZhen,GuangDong,China
 Tel:+86-755-26639495-7
 Fax:+86-755-26632877
 Postcode:518057

Data: 28 File: E:\2009 report data\TP-LINK\ACS9Q1514.EM6 (56)

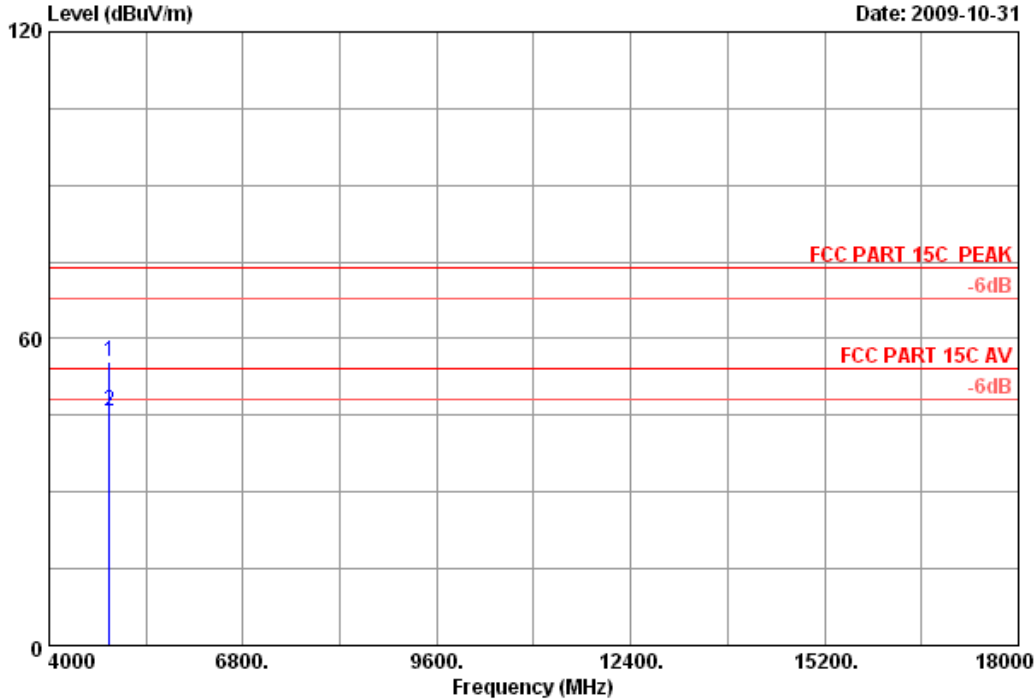

Site no. : 3m Chamber Data no. : 28
 Dis. / Ant. : 3m 3115(0905) Ant. pol. : VERTICAL
 Limit : FCC PART 15C PEAK
 Env. / Ins. : 23°C/54% Engineer : Sunny-lu
 EUT : 54M Wireless Router
 Power : DC 9V From Adapter Input AC 120V/60Hz
 Test mode : IEEE802.11g CH6 2437MHz Tx
 M/N : MRO-WR542G

	Freq. (MHz)	Ant. Factor (dB/m)	Cable loss (dB)	Amp. Factor (dB)	Reading (dbuv)	Emission Level (dBuV/m)	Limits (dBuV/m)	Margin (dB)	Remark
1	4874.000	34.78	12.23	35.36	43.95	55.60	74.00	18.40	Peak
2	4874.000	34.78	12.23	35.36	34.23	45.88	54.00	8.12	Average

Remarks:

1. Emission Level= Antenna Factor + Cable Loss -Amp Factor + Reading.
2. The emission levels that are 20dB below the official limit are not reported.



No.6 Ke Feng Road,Block 52,
ShenZhen Science & Industry Park
Noutou,ShenZhen,GuangDong,China
Tel:+86-755-26639495-7
Fax:+86-755-26632877
Postcode:518057

Data: 29 File: E:\2009 report data\T\TP-LINK\ACS9Q1514.EM6 (56)

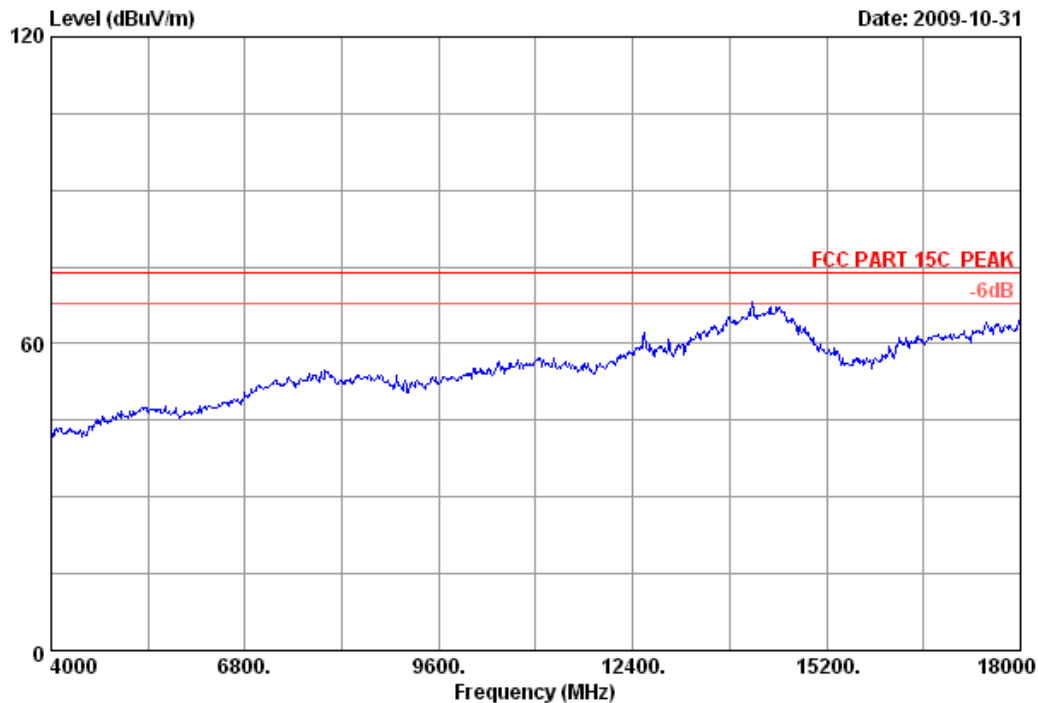

Site no.	: 3m Chamber	Data no.	: 29
Dis. / Ant.	: 3m 3115(0905)	Ant. pol.	: HORIZONTAL
Limit	: FCC PART 15C PEAK		
Env. / Ins.	: 23°C/54%	Engineer	: Sunny-lu
EUT	: 54M Wireless Router		
Power	: DC 9V From Adapter Input AC 120V/60Hz		
Test mode	: IEEE802.11g CH6 2437MHz Tx		
M/N	: MRO-WR542G		



No.6 Ke Feng Road,Block 52,
 ShenZhen Science & Industry Park
 Noutou,ShenZhen,GuangDong,China
 Tel:+86-755-26639495-7
 Fax:+86-755-26632877
 Postcode:518057

Data: 30 File: E:\2009 report data\TP-LINK\ACS9Q1514.EM6 (56)

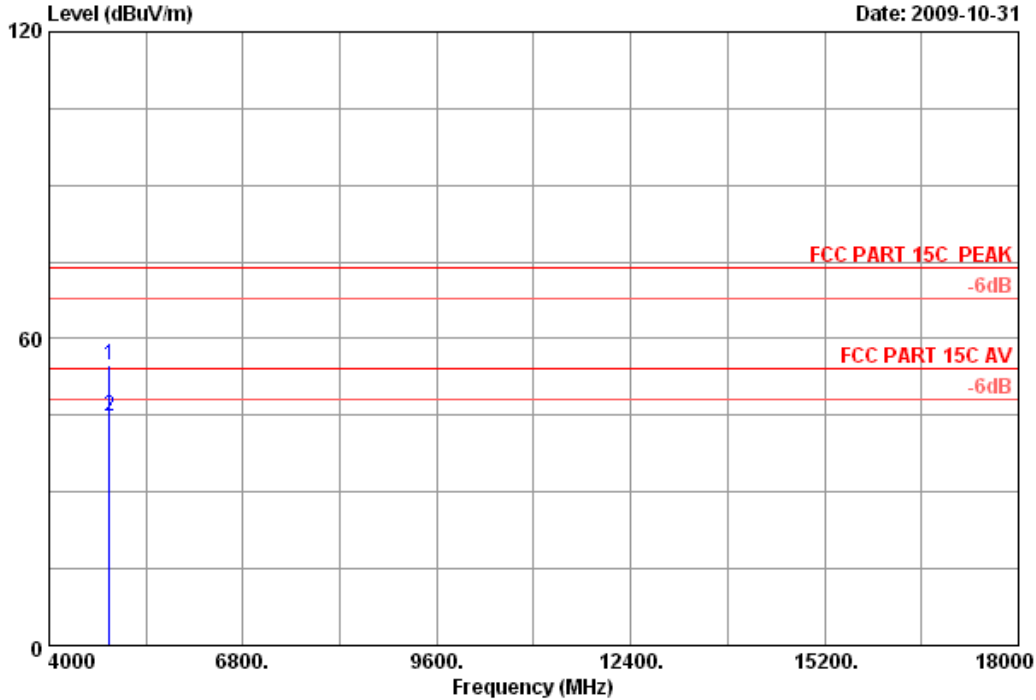

Site no. : 3m Chamber Data no. : 30
 Dis. / Ant. : 3m 3115(0905) Ant. pol. : HORIZONTAL
 Limit : FCC PART 15C PEAK
 Env. / Ins. : 23°C/54% Engineer : Sunny-lu
 EUT : 54M Wireless Router
 Power : DC 9V From Adapter Input AC 120V/60Hz
 Test mode : IEEE802.11g CH6 2437MHz Tx
 M/N : MRO-WR542G

	Freq. (MHz)	Ant. Factor (dB/m)	Cable loss (dB)	Amp. Factor (dB)	Reading (dbuv)	Emission Level (dBuV/m)	Limits (dBuV/m)	Margin (dB)	Remark
1	4874.000	34.78	12.23	35.36	43.27	54.92	74.00	19.08	Peak
2	4874.000	34.78	12.23	35.36	33.17	44.82	54.00	9.18	Average

Remarks:

1. Emission Level= Antenna Factor + Cable Loss -Amp Factor + Reading.
2. The emission levels that are 20dB below the official limit are not reported.



No.6 Ke Feng Road,Block 52,
 ShenZhen Science & Industry Park
 Noutou,ShenZhen,GuangDong,China
 Tel:+86-755-26639495-7
 Fax:+86-755-26632877
 Postcode:518057

Data: 31 File: E:\2009 report data\TP-LINK\ACS9Q1514.EM6 (56)

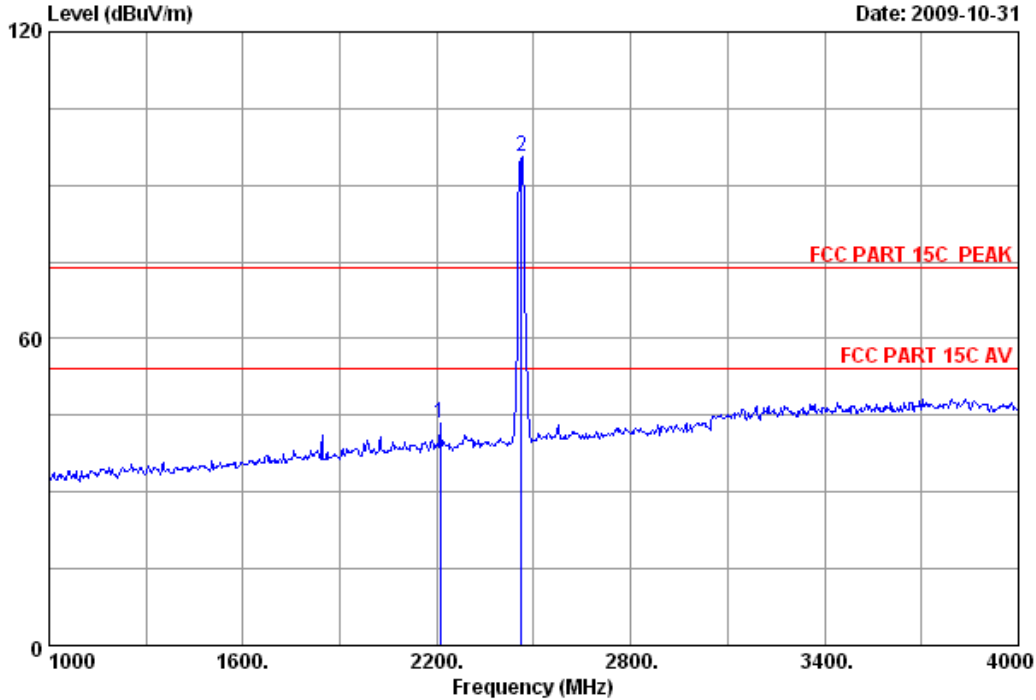

Site no. : 3m Chamber Data no. : 31
 Dis. / Ant. : 3m 3115(0905) Ant. pol. : HORIZONTAL
 Limit : FCC PART 15C PEAK
 Env. / Ins. : 23°C/54% Engineer : Sunny-lu
 EUT : 54M Wireless Router
 Power : DC 9V From Adapter Input AC 120V/60Hz
 Test mode : IEEE802.11g CH11 2462MHz Tx
 M/N : MRO-WR542G

	Ant. Freq. (MHz)	Factor (dB/m)	Cable loss (dB)	Amp. Factor (dB)	Reading (dbuv)	Emission Level (dBuV/m)	Limits (dBuV/m)	Margin (dB)	Remark
1	2209.000	28.19	8.36	36.02	43.08	43.61	74.00	30.39	Peak
2	2462.000	28.55	8.76	36.02	94.26	95.55	74.00	-21.55	Peak

Remarks:

1. Emission Level= Antenna Factor + Cable Loss -Amp Factor + Reading.
2. The emission levels that are 20dB below the official limit are not reported.



No.6 Ke Feng Road,Block 52,
ShenZhen Science & Industry Park
Noutou,ShenZhen,GuangDong,China
Tel:+86-755-26639495-7
Fax:+86-755-26632877
Postcode:518057

Data: 32 File: E:\2009 report data\TP-LINK\ACS9Q1514.EM6 (56)

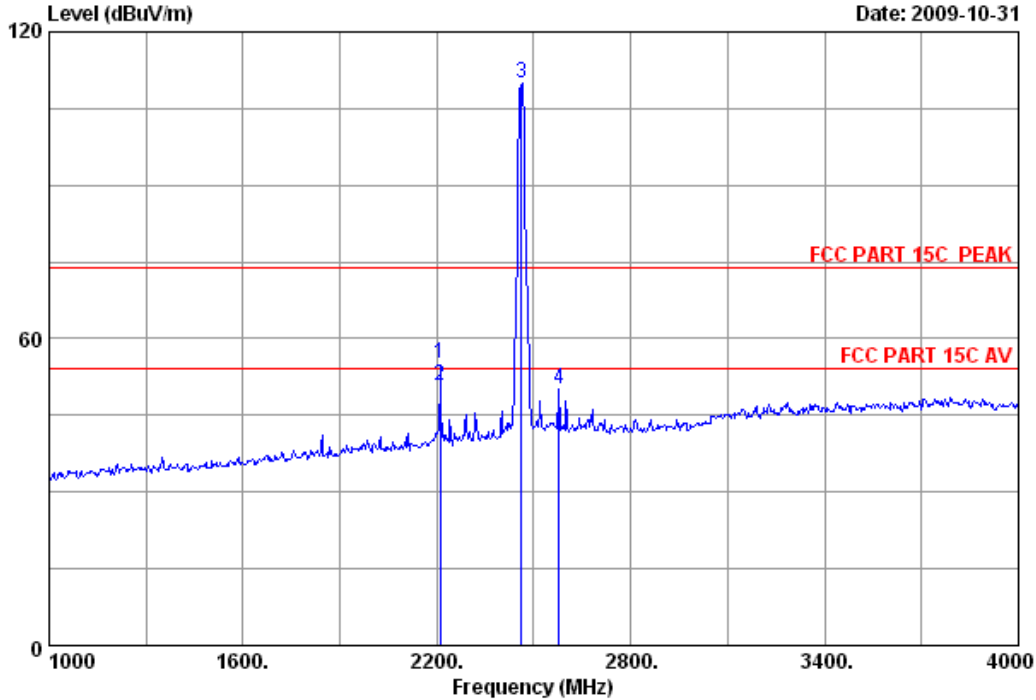

Site no. : 3m Chamber Data no. : 32
 Dis. / Ant. : 3m 3115(0905) Ant. pol. : VERTICAL
 Limit : FCC PART 15C PEAK
 Env. / Ins. : 23*C/54% Engineer : Sunny-lu
 EUT : 54M Wireless Router
 Power : DC 9V From Adapter Input AC 120V/60Hz
 Test mode : IEEE802.11g CH11 2462MHz Tx
 M/N : MRO-WR542G

	Freq. (MHz)	Ant. Factor (dB/m)	Cable loss (dB)	Amp. Factor (dB)	Reading (dbuv)	Emission			Remark
						Level (dBuV/m)	Limits (dBuV/m)	Margin (dB)	
1	2209.000	28.19	8.36	36.02	54.51	55.04	74.00	18.96	Peak
2	2209.000	28.19	8.36	36.02	50.35	50.88	54.00	3.12	Average
3	2462.000	28.55	8.76	36.02	108.64	109.93	74.00	-35.93	Peak
4	2578.000	28.87	9.21	35.78	47.71	50.01	74.00	23.99	Peak

Remarks:

1. Emission Level= Antenna Factor + Cable Loss -Amp Factor + Reading.
2. The emission levels that are 20dB below the official limit are not reported.



No.6 Ke Feng Road,Block 52,
ShenZhen Science & Industry Park
Noutou,ShenZhen,GuangDong,China
Tel:+86-755-26639495-7
Fax:+86-755-26632877
Postcode:518057

Data: 33 File: E:\2009 report data\T\TP-LINK\ACS9Q1514.EM6 (56)

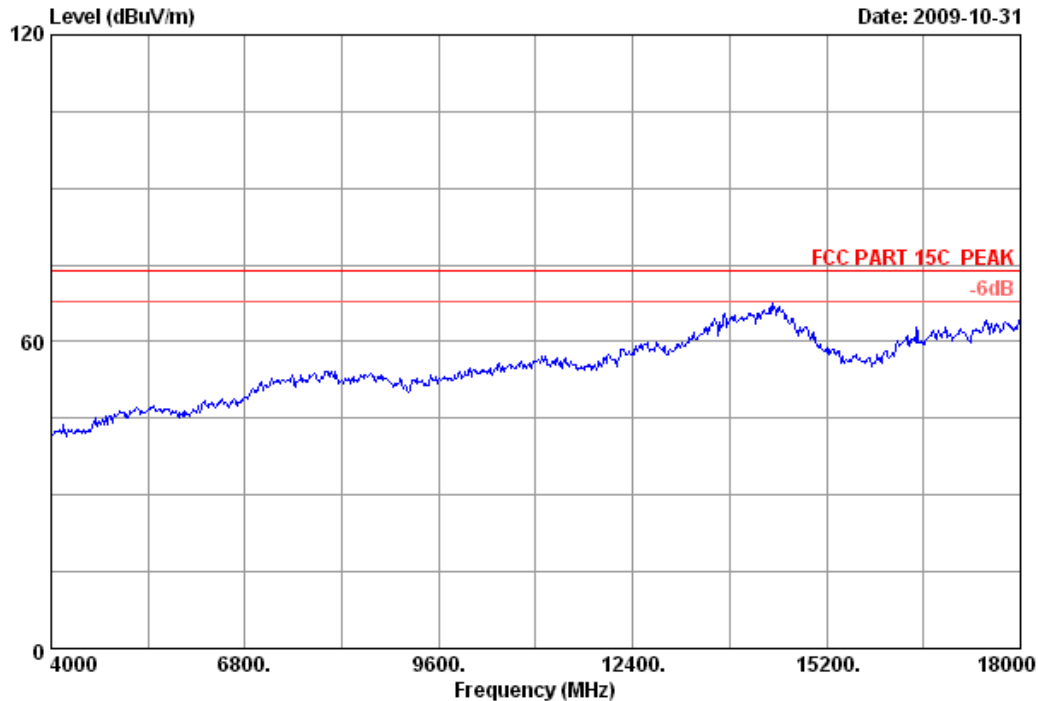

Site no.	: 3m Chamber	Data no.	: 33
Dis. / Ant.	: 3m 3115(0905)	Ant. pol.	: HORIZONTAL
Limit	: FCC PART 15C PEAK		
Env. / Ins.	: 23°C/54%	Engineer	: Sunny-lu
EUT	: 54M Wireless Router		
Power	: DC 9V From Adapter Input AC 120V/60Hz		
Test mode	: IEEE802.11g CH11 2462MHz Tx		
M/N	: MRO-WR542G		



No.6 Ke Feng Road,Block 52,
 ShenZhen Science & Industry Park
 Noutou,ShenZhen,GuangDong,China
 Tel:+86-755-26639495-7
 Fax:+86-755-26632877
 Postcode:518057

Data: 34 File: E:\2009 report data\TP-LINK\ACS9Q1514.EM6 (56)

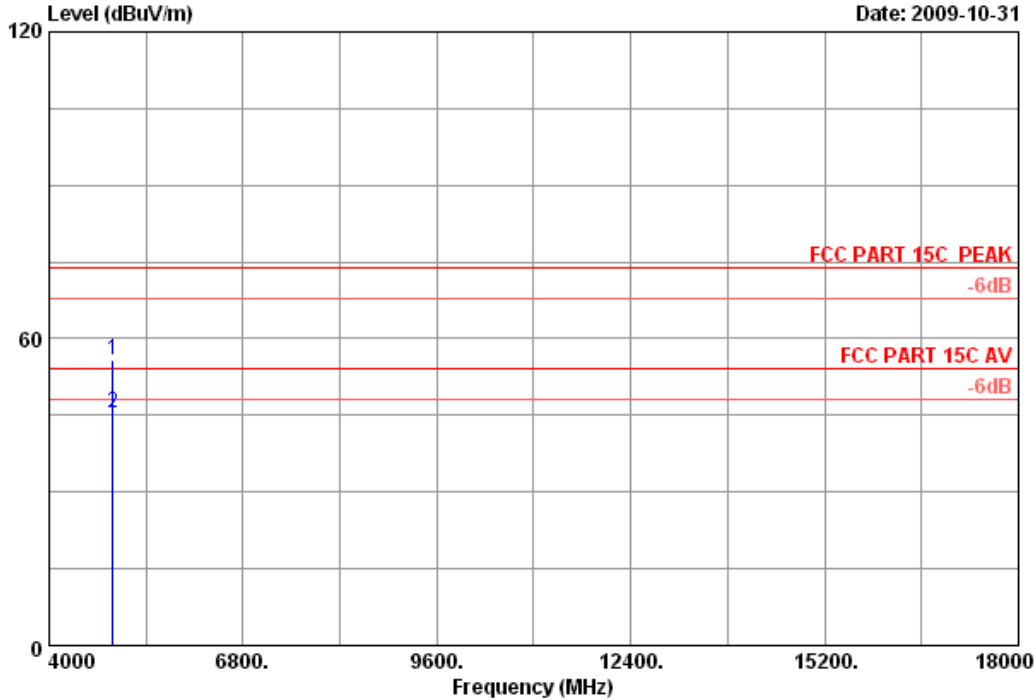

Site no. : 3m Chamber Data no. : 34
 Dis. / Ant. : 3m 3115(0905) Ant. pol. : HORIZONTAL
 Limit : FCC PART 15C PEAK
 Env. / Ins. : 23°C/54% Engineer : Sunny-lu
 EUT : 54M Wireless Router
 Power : DC 9V From Adapter Input AC 120V/60Hz
 Test mode : IEEE802.11g CH11 2462MHz Tx
 M/N : MRO-WR542G

	Ant.	Cable	Amp.	Emission					
Freq.	Factor	loss	Factor	Reading	Level	Limits	Margin	Remark	
(MHz)	(dB/m)	(dB)	(dB)	(dbuv)	(dBuV/m)	(dBuV/m)	(dB)		
1 4924.000	35.09	12.58	35.34	43.59	55.92	74.00	18.08	Peak	
2 4924.000	35.09	12.58	35.34	33.18	45.51	54.00	8.49	Average	

Remarks:

1. Emission Level= Antenna Factor + Cable Loss -Amp Factor + Reading.
2. The emission levels that are 20dB below the official limit are not reported.



No.6 Ke Feng Road,Block 52,
ShenZhen Science & Industry Park
Noutou,ShenZhen,GuangDong,China
Tel:+86-755-26639495-7
Fax:+86-755-26632877
Postcode:518057

Data: 35 File: E:\2009 report data\T\TP-LINK\ACS9Q1514.EM6 (56)

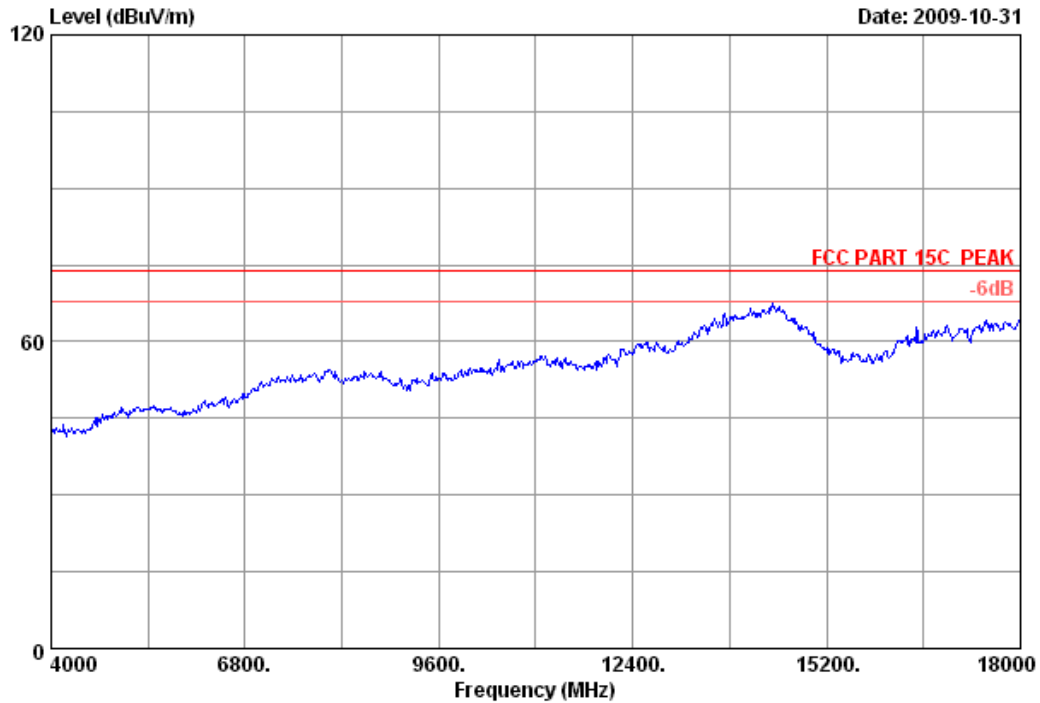

Site no.	: 3m Chamber	Data no.	: 35
Dis. / Ant.	: 3m 3115(0905)	Ant. pol.	: VERTICAL
Limit	: FCC PART 15C PEAK		
Env. / Ins.	: 23°C/54%	Engineer	: Sunny-lu
EUT	: 54M Wireless Router		
Power	: DC 9V From Adapter Input AC 120V/60Hz		
Test mode	: IEEE802.11g CH11 2462MHz Tx		
M/N	: MRO-WR542G		



No.6 Ke Feng Road,Block 52,
ShenZhen Science & Industry Park
Noutou,ShenZhen,GuangDong,China
Tel:+86-755-26639495-7
Fax:+86-755-26632877
Postcode:518057

Data: 36 File: E:\2009 report data\TP-LINK\ACS9Q1514.EM6 (56)

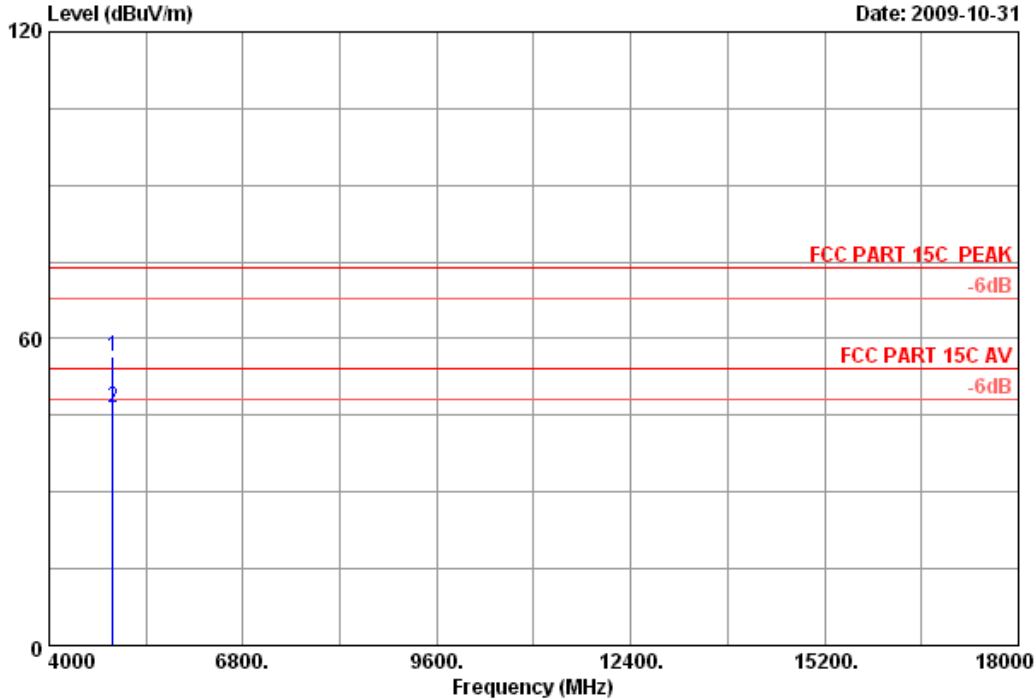

Site no. : 3m Chamber Data no. : 36
 Dis. / Ant. : 3m 3115(0905) Ant. pol. : VERTICAL
 Limit : FCC PART 15C PEAK
 Env. / Ins. : 23°C/54% Engineer : Sunny-lu
 EUT : 54M Wireless Router
 Power : DC 9V From Adapter Input AC 120V/60Hz
 Test mode : IEEE802.11g CH11 2462MHz Tx
 M/N : MRO-WR542G

	Freq. (MHz)	Ant. Factor (dB/m)	Cable loss (dB)	Amp. Factor (dB)	Reading (dbuv)	Emission Level (dBuV/m)	Limits (dBuV/m)	Margin (dB)	Remark
1	4924.000	35.09	12.58	35.34	44.12	56.45	74.00	17.55	Peak
2	4924.000	35.09	12.58	35.34	34.24	46.57	54.00	7.43	Average

Remarks:

1. Emission Level= Antenna Factor + Cable Loss -Amp Factor + Reading.
2. The emission levels that are 20dB below the official limit are not reported.

5. CONDUCTED SPURIOUS EMISSIONS

5.1. Test Equipment

Item	Equipment	Manufacturer	Model No.	Serial No.	Last Cal.	Cal. Interval
1.	Spectrum Analyzer	Agilent	E4446A	US44300459	May.08, 09	1 Year
2.	Attenuator	Agilent	8491B	MY39262165	May.08, 09	1 Year
3.	RF Cable	Hubersuhner	SUCOFLEX 102	28618/2	May.08, 09	1Year

5.2. Limit

In any 100kHz bandwidth outside the frequency bands in which the spread spectrum intentional radiator is operating, the radio frequency power that is produced by the intentional radiator shall be at least 20dB below that in the 100kHz bandwidth within the band that contains the highest level of the desired power. In addition, radiated emissions which fall in the restricted bands, as defined in §15.205(a), must also comply with the radiated emission limits specified in 15.209(a).

5.3. Test Procedure

The transmitter output was connected to a spectrum analyzer, The resolution bandwidth is set to 100 kHz, The video bandwidth is set to 300 kHz.

5.4. Test result

PASS (The testing data was attached in the next pages.)

Conducted emission test data:

Test Mode: IEEE 802.11b TX

Test CH1: 2412MHz

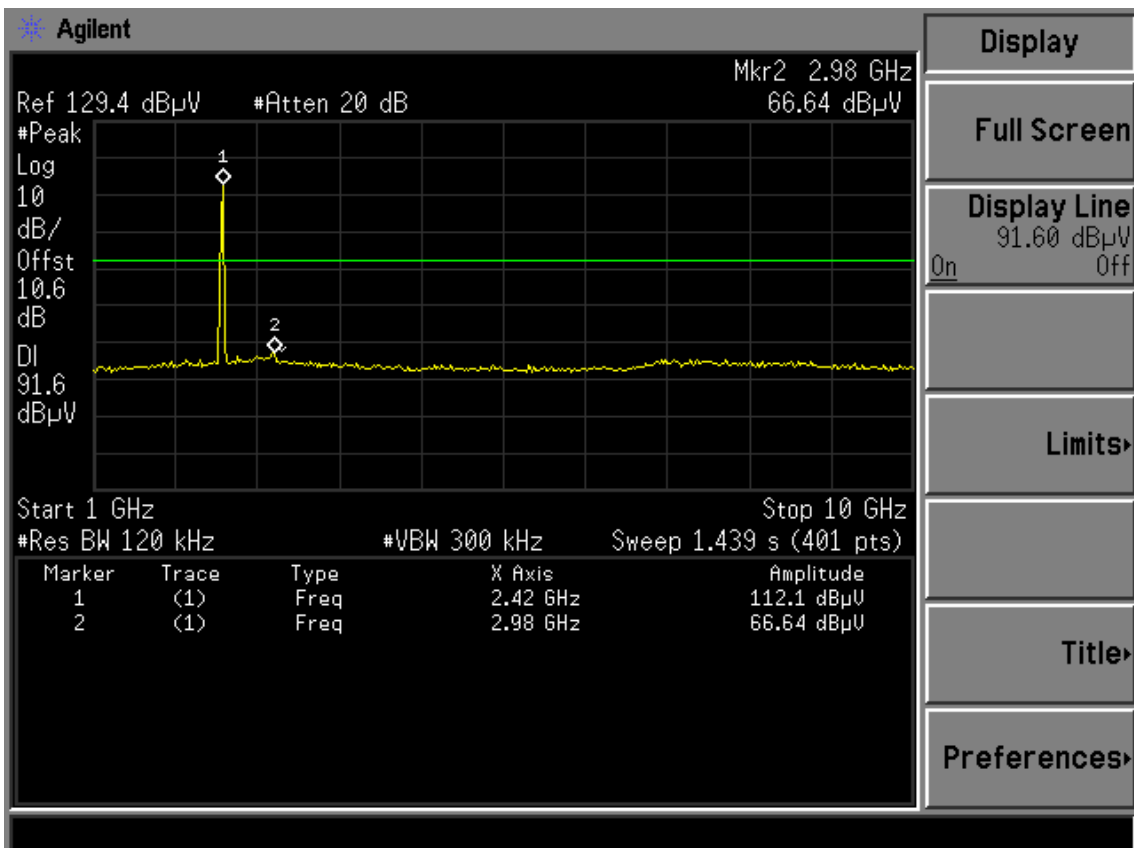
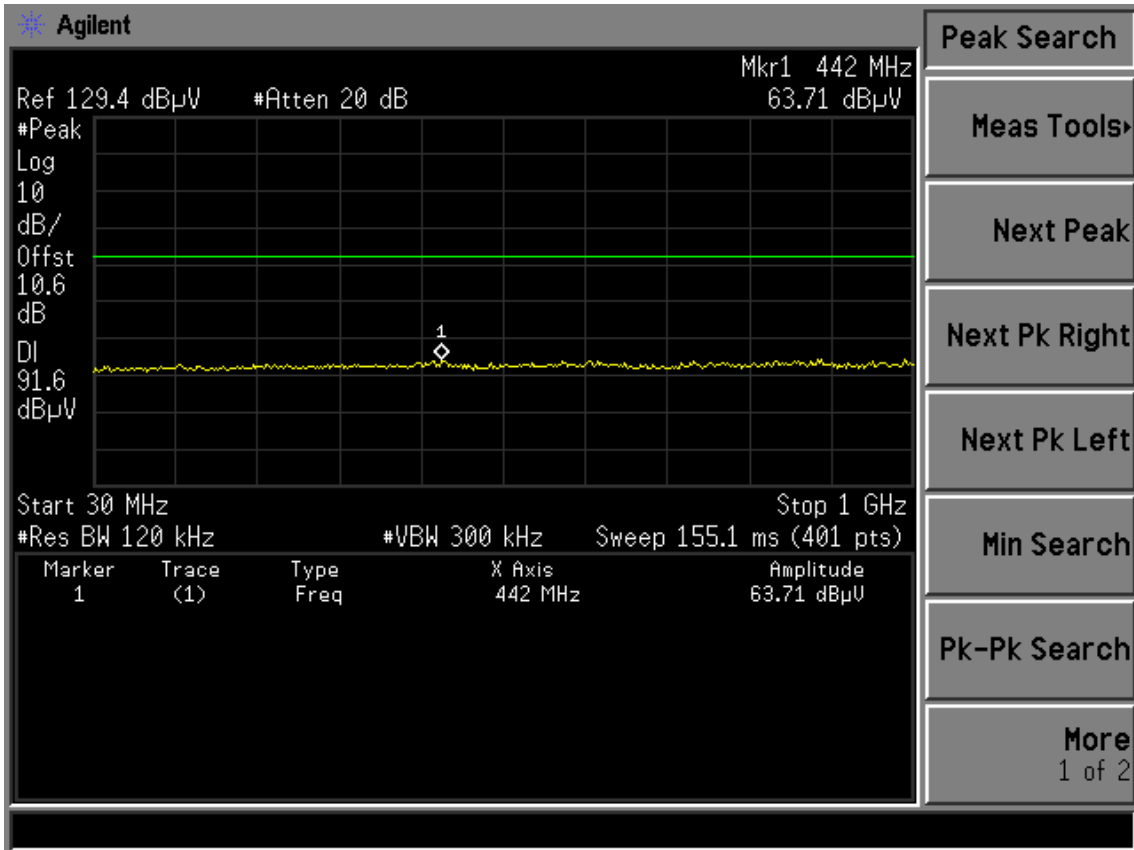

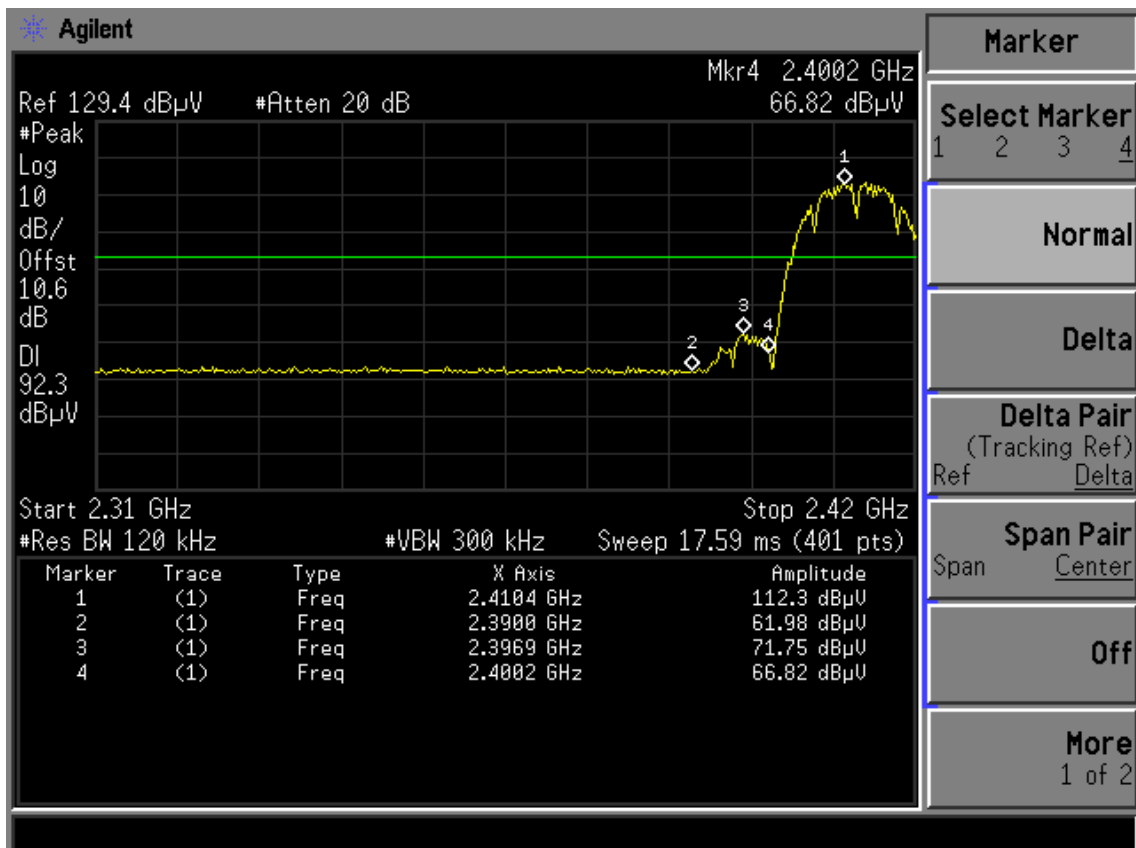
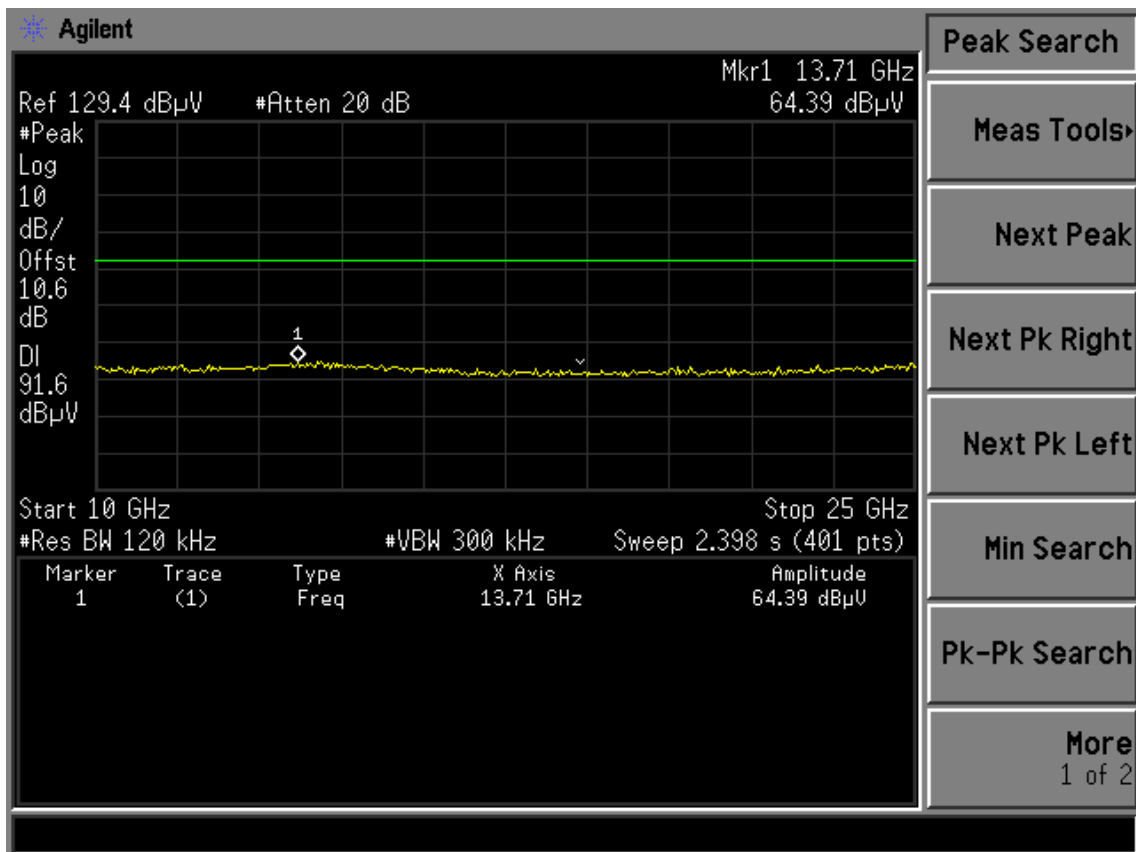

Test CH6: 2437MHz

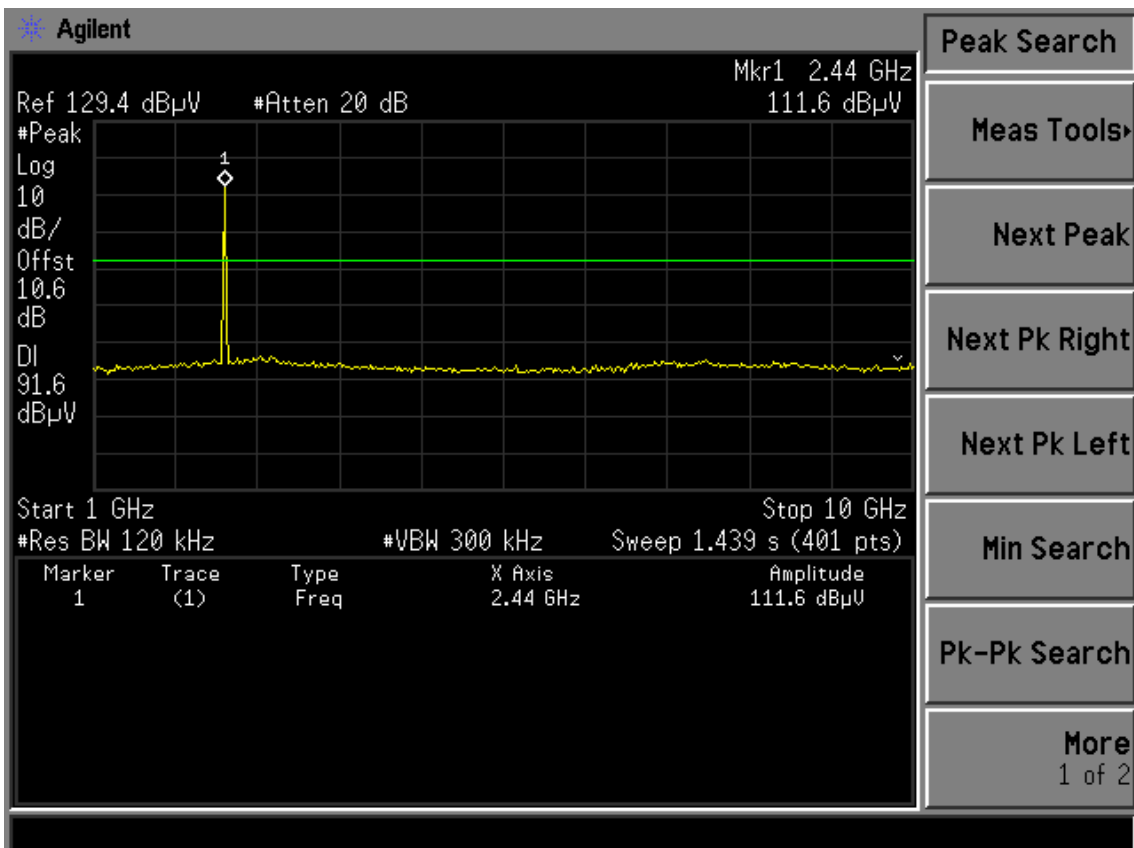
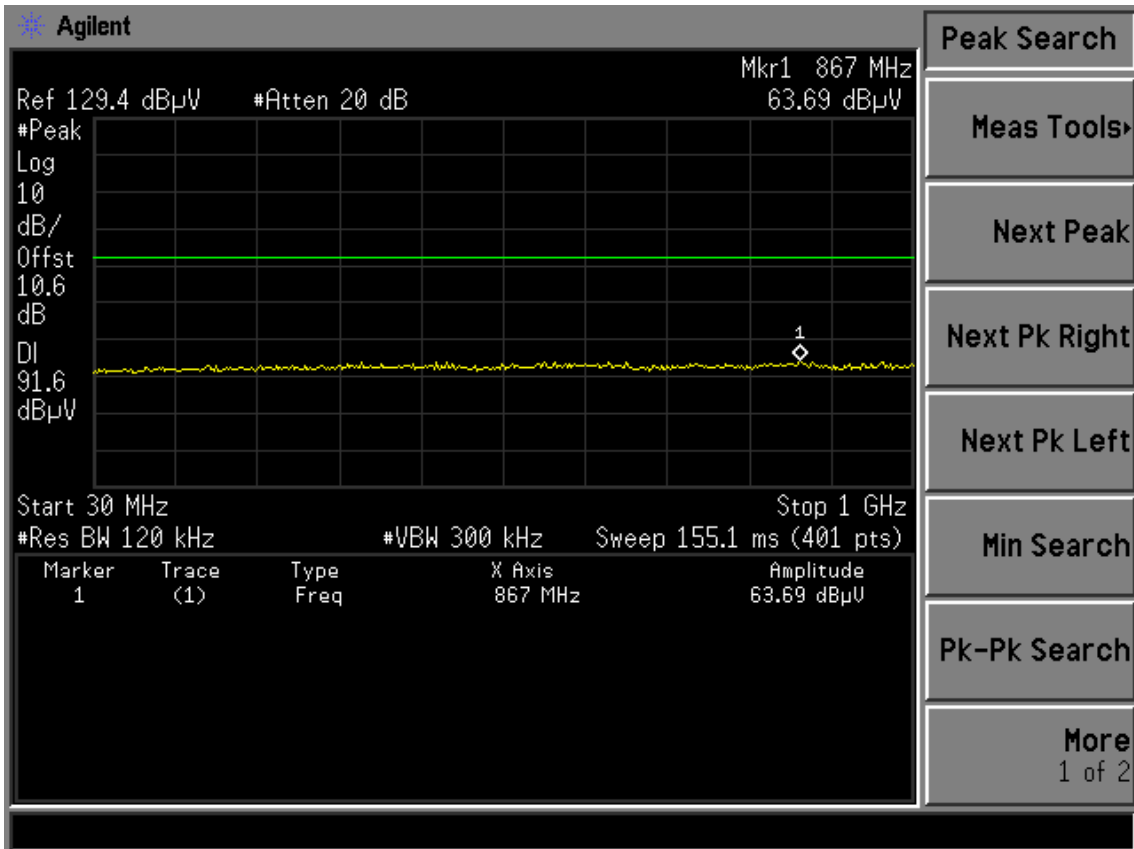

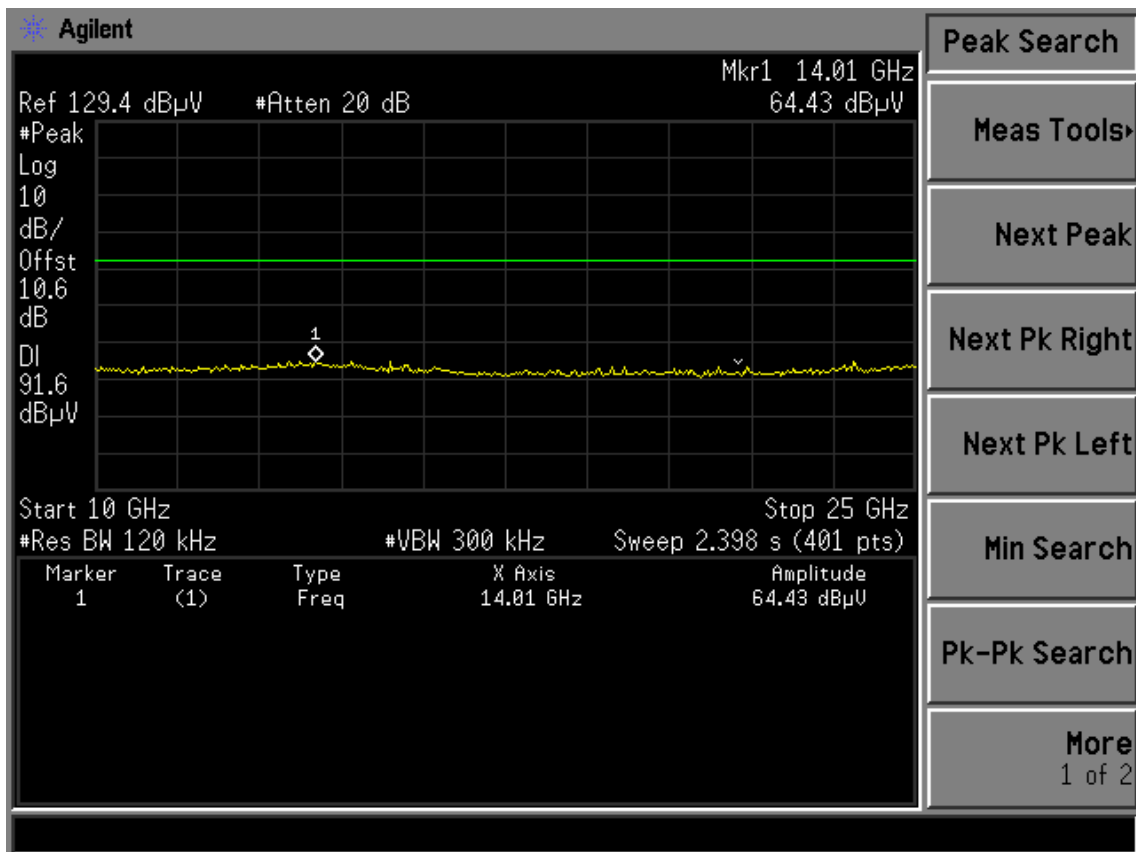

Test CH11: 2462MHz

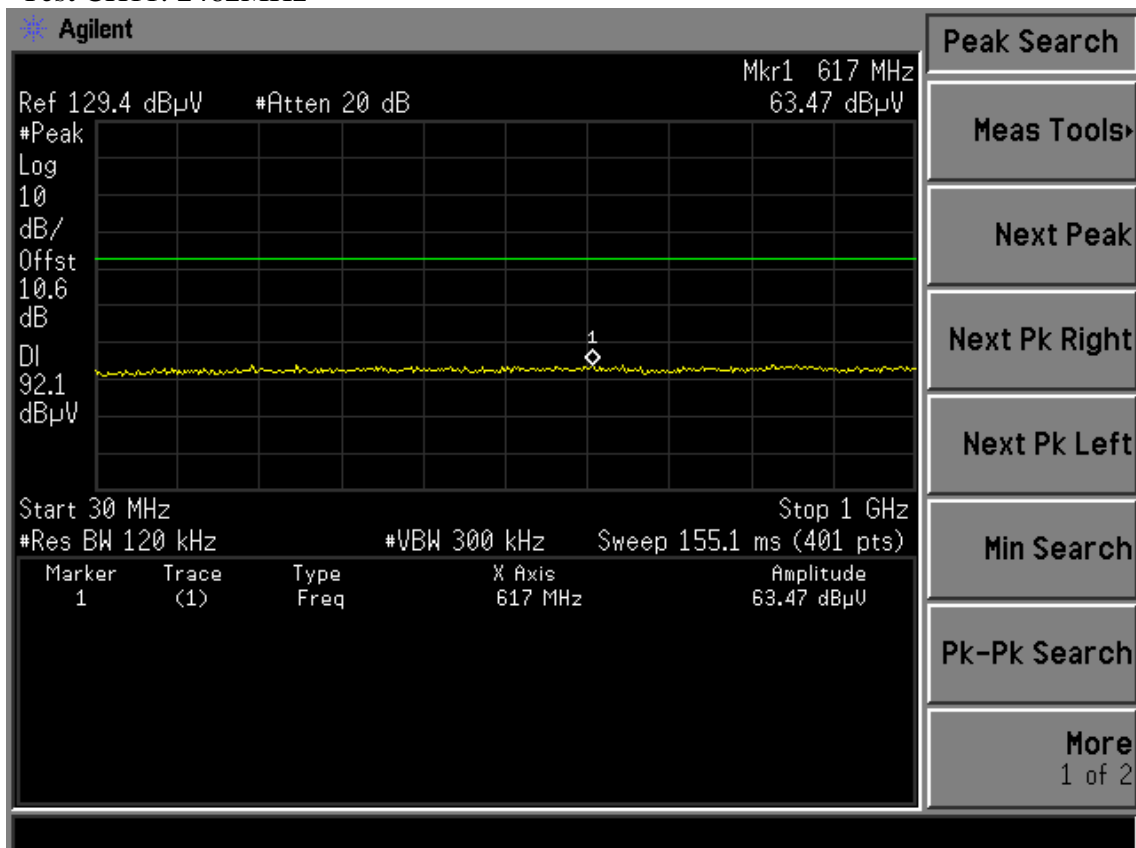

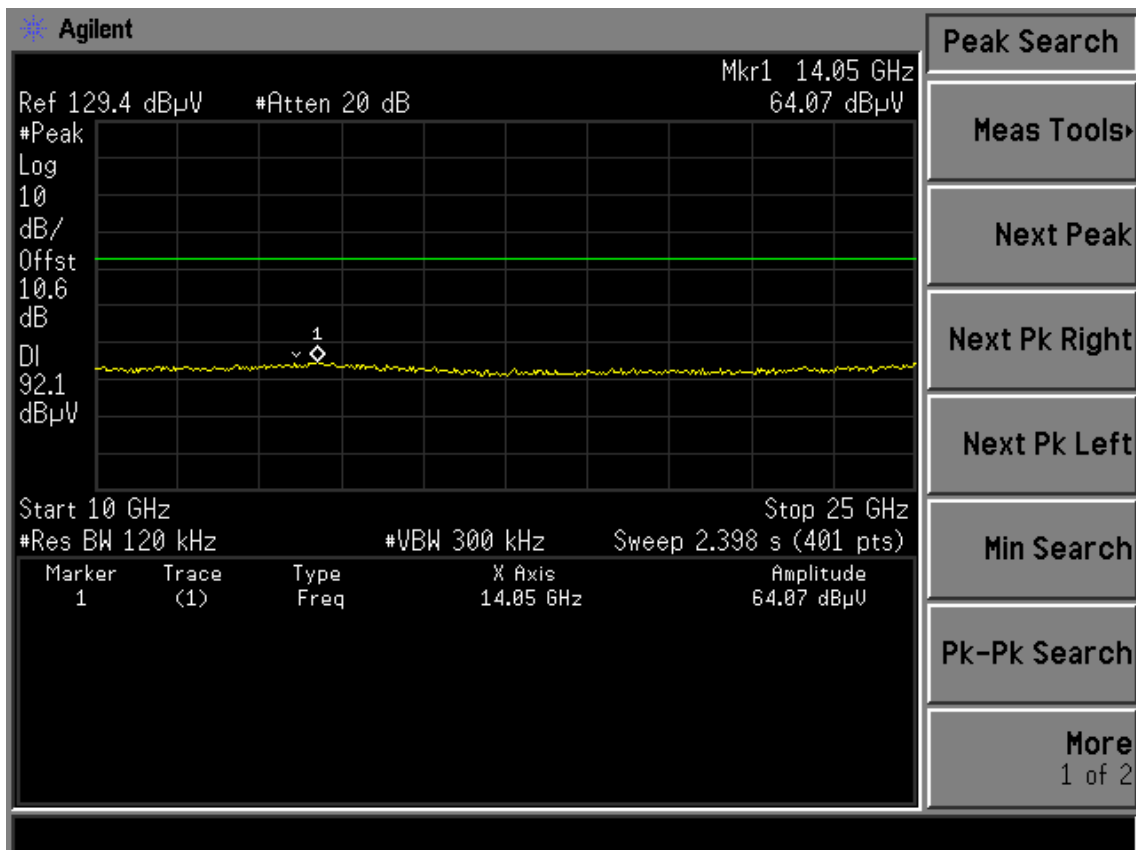
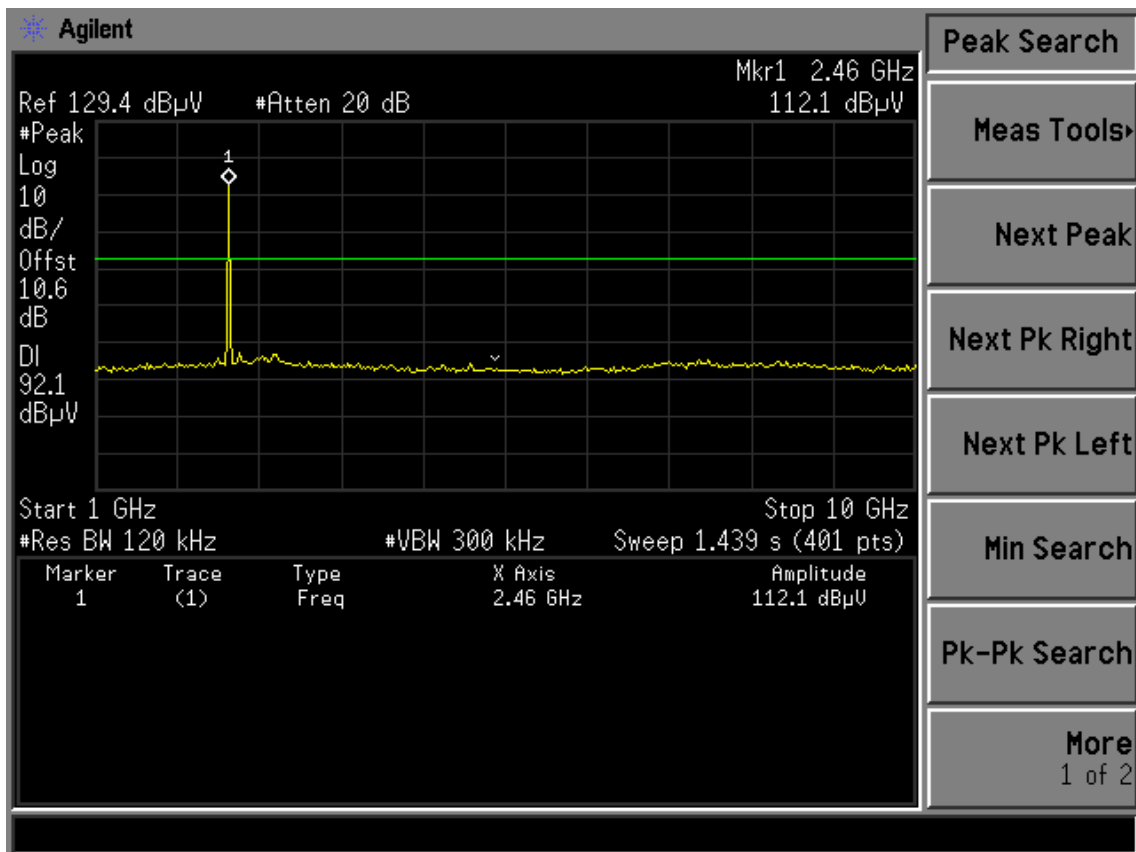

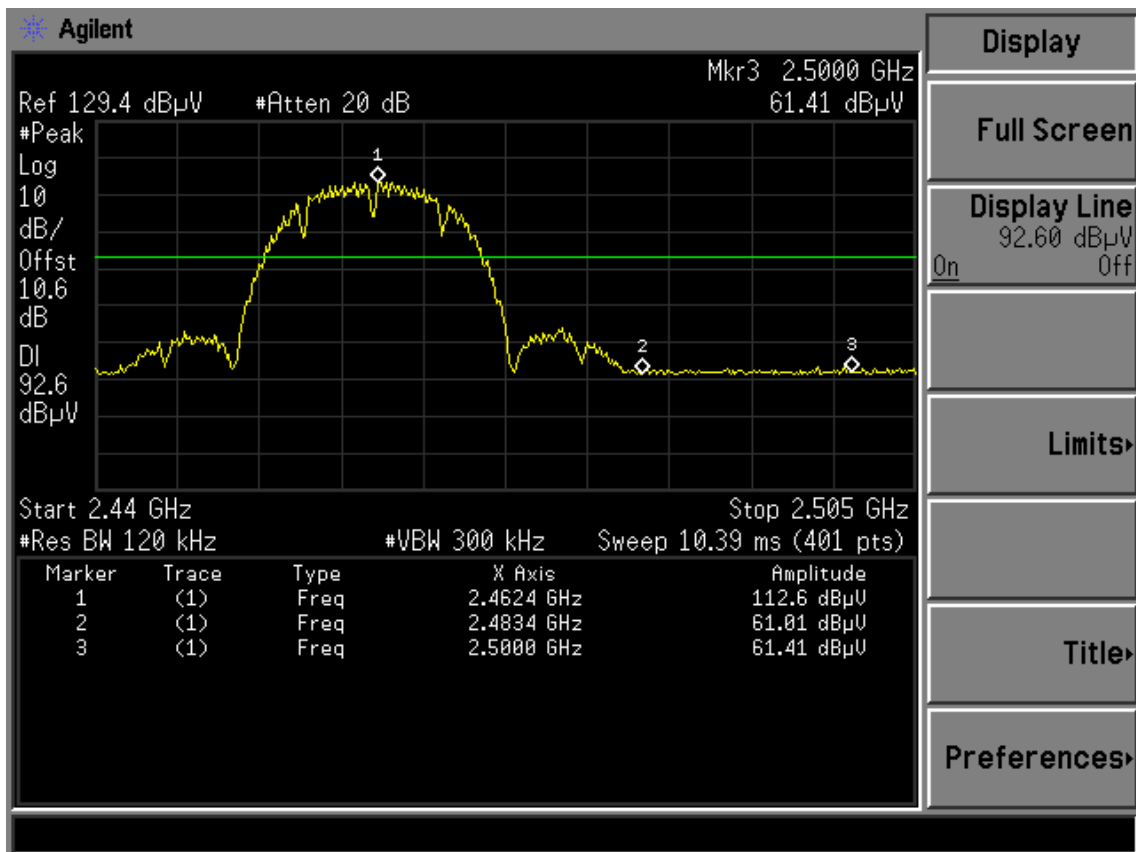

Test Mode: IEEE 802.11g TX

Test CH1: 2412MHz

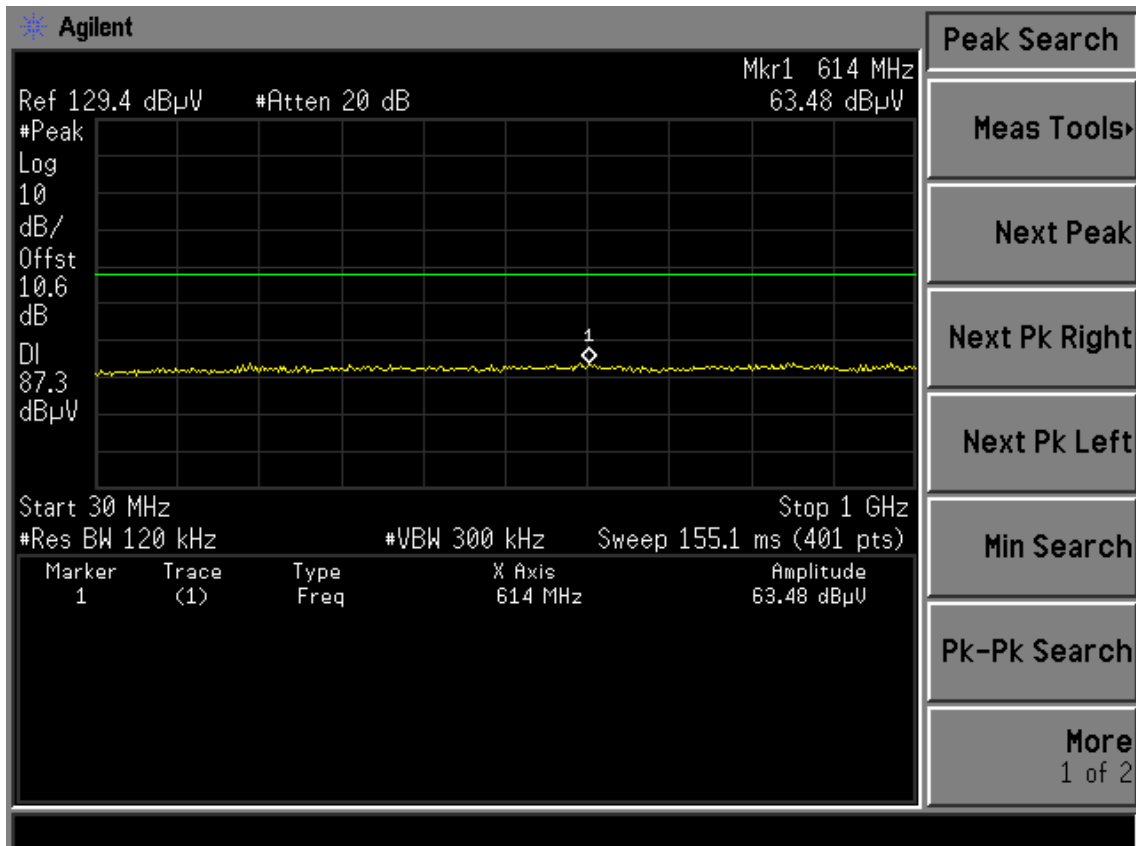

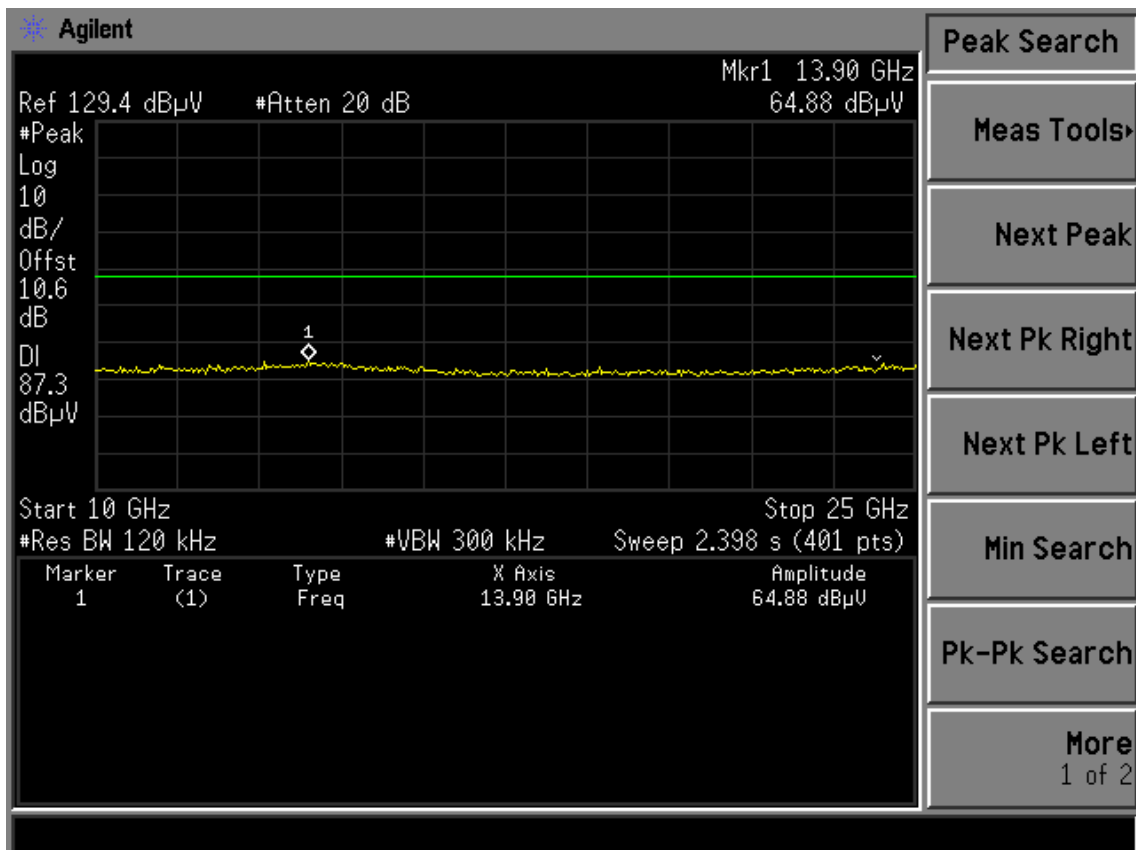
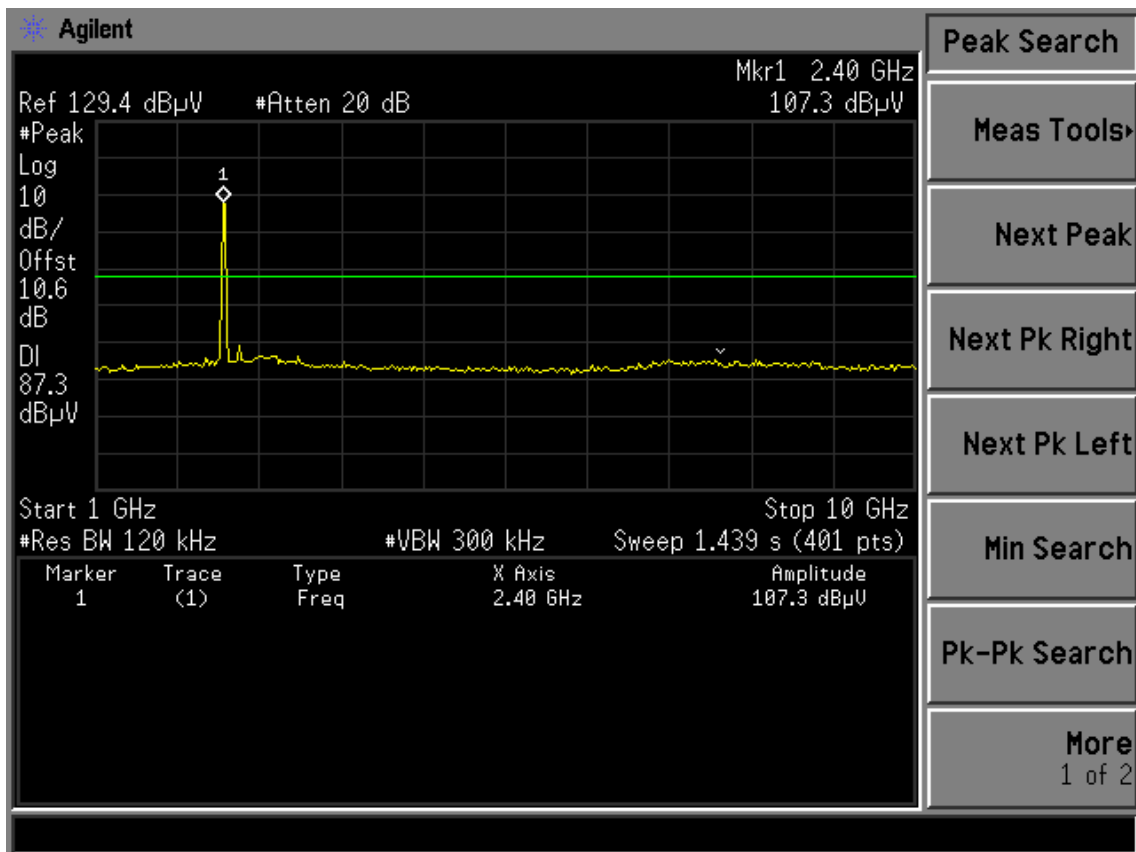

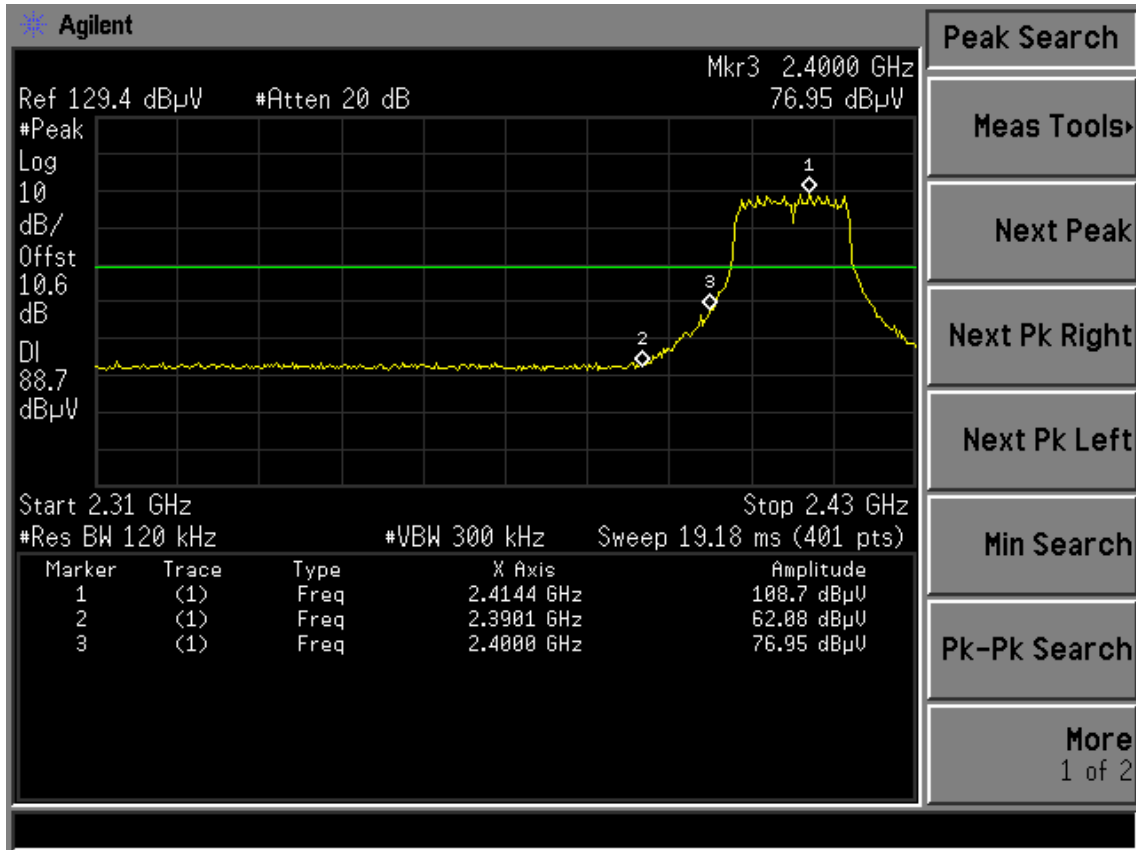

Test CH6: 2437MHz

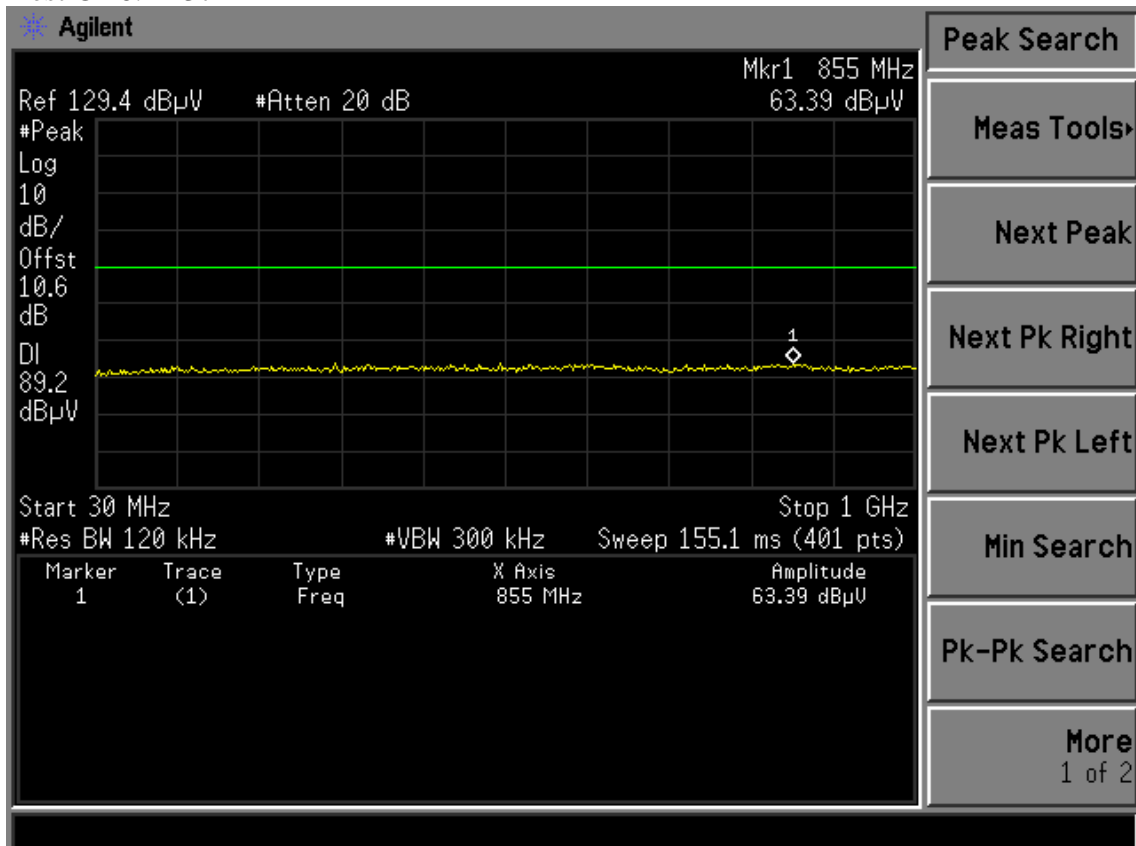

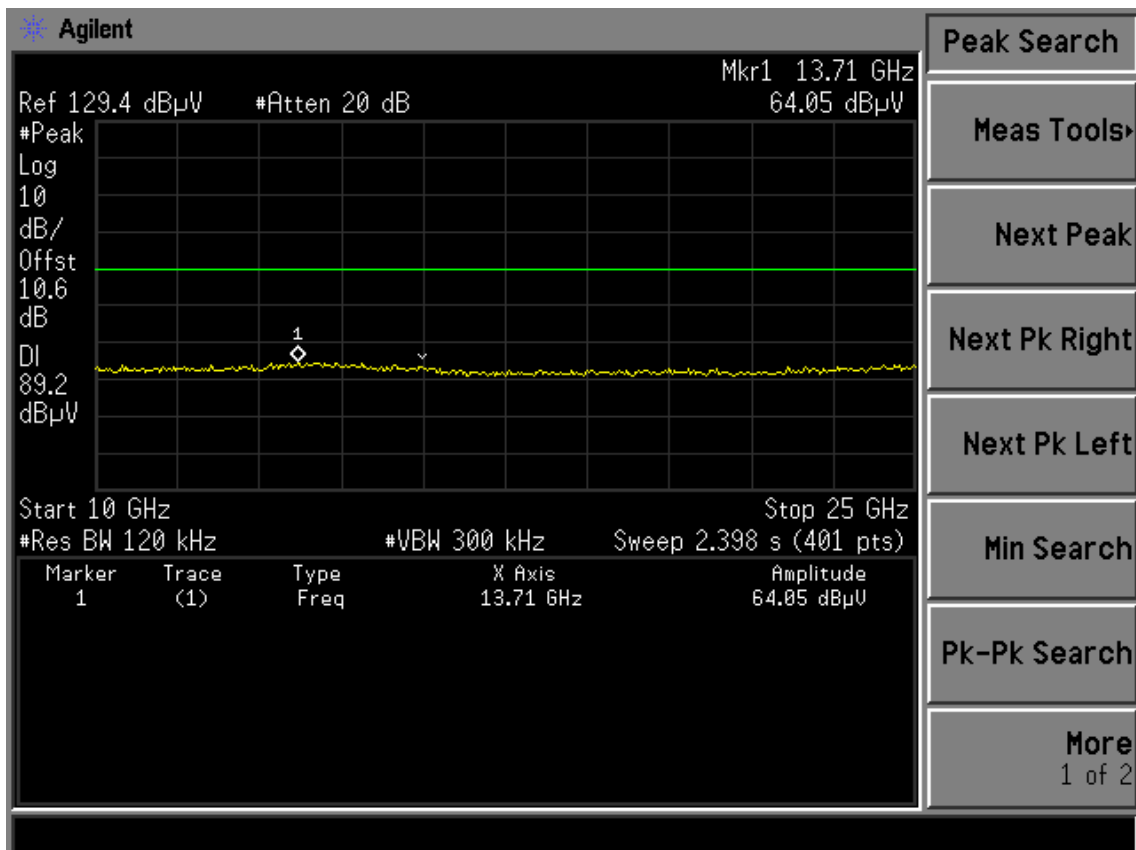
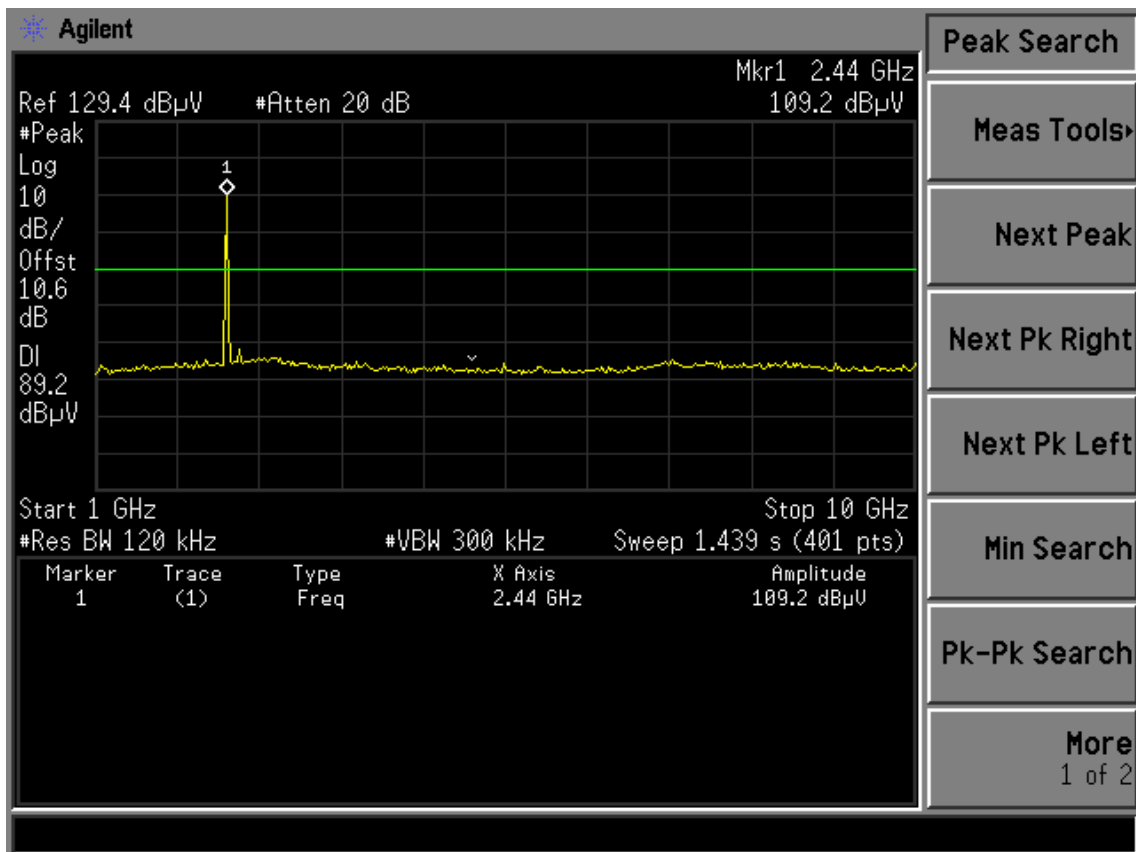

Test CH11: 2462MHz

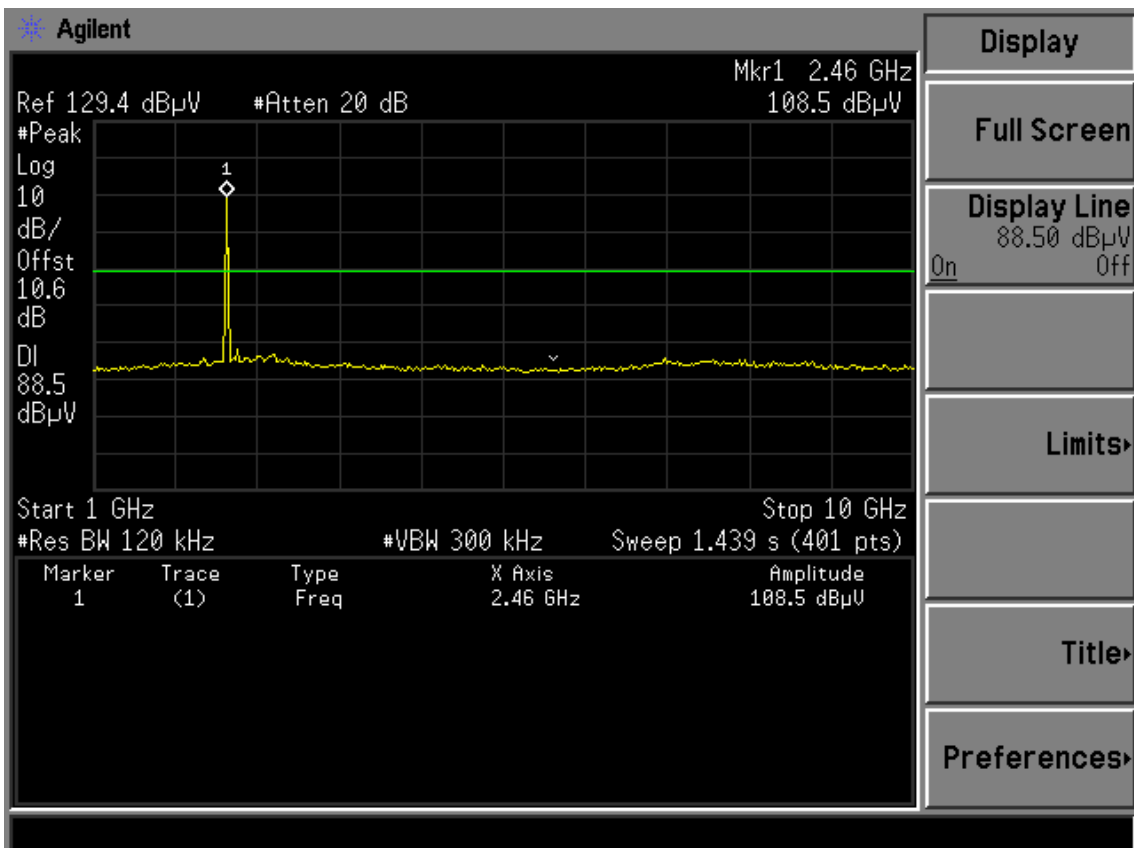
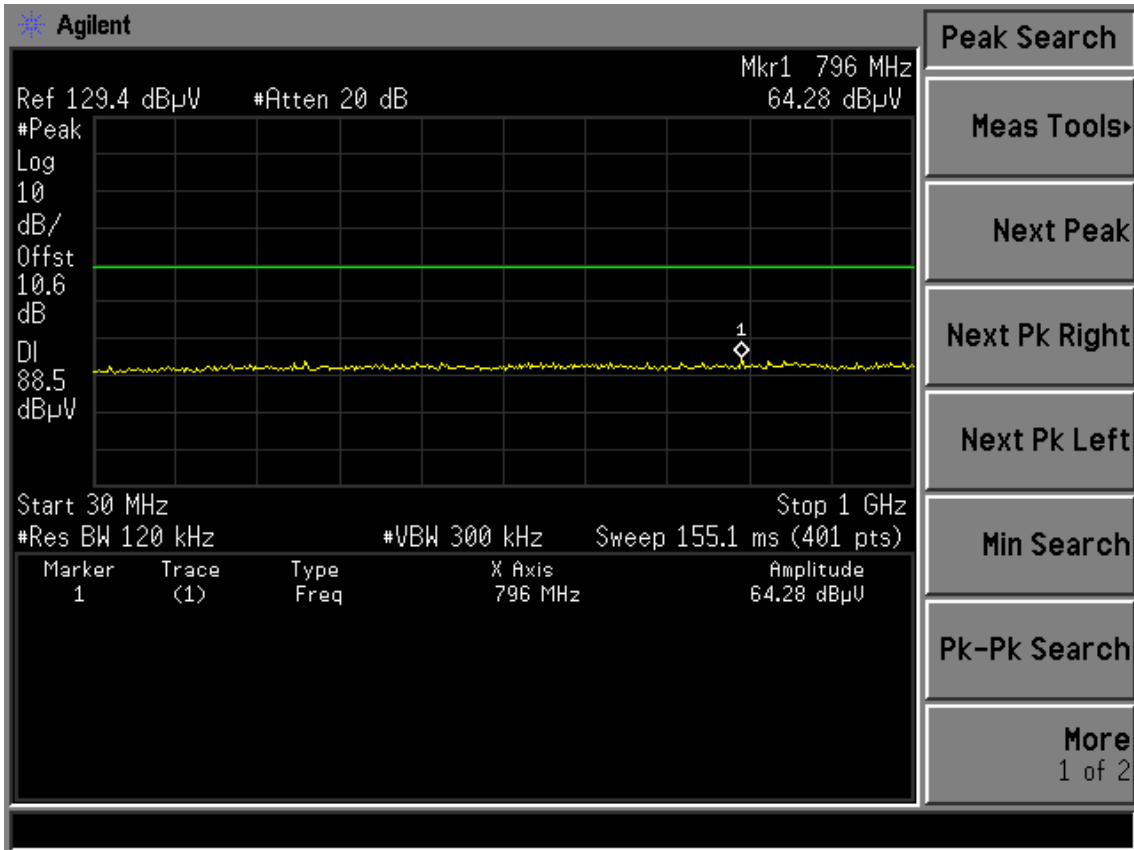

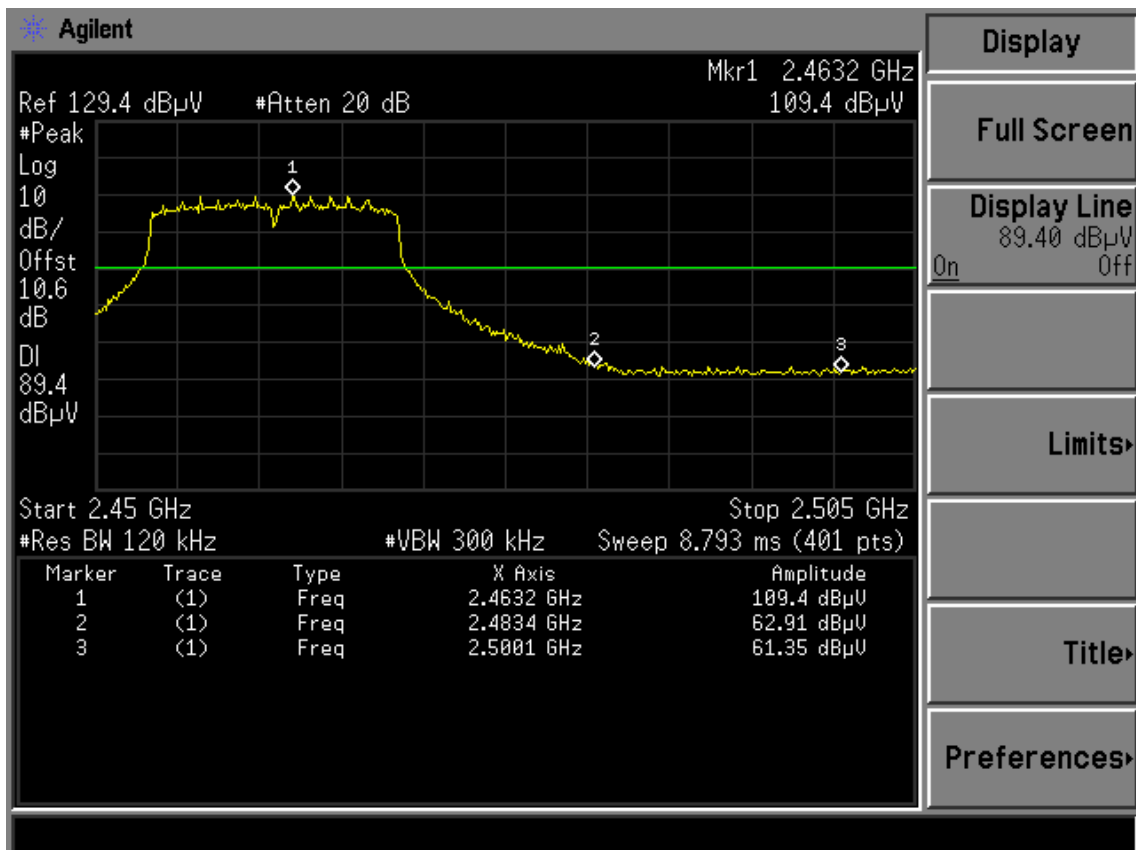
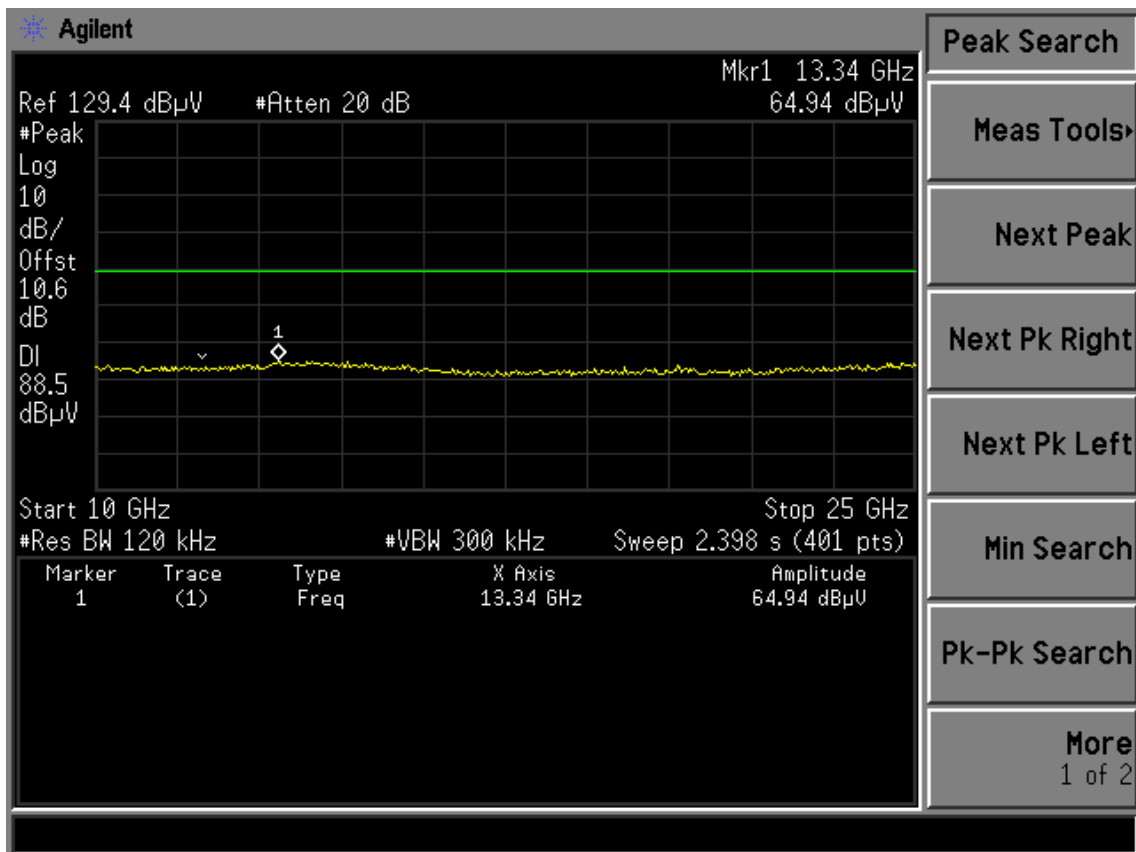

6. BAND EDGE COMPLIANCE TEST

6.1. Test Equipment

Item	Equipment	Manufacturer	Model No.	Serial No.	Last Cal.	Cal. Interval
1.	Spectrum Analyzer	Agilent	E4446A	US44300459	May.08, 09	1 Year
2.	Horn Antenna	EMCO	3115	9607-4877	May.27, 08	1.5 Year
3.	Amplifier	Agilent	8449B	3008A02495	May.08, 09	1 Year
4.	RF Cable	Hubersuhner	SUCOFLEX 102	28620/2	May.08, 09	1 Year
5.	RF Cable	Hubersuhner	SUCOFLEX 102	271471/4	May.08, 09	1 Year
6.	RF Cable	Hubersuhner	SUCOFLEX 102	29086/2	May.08, 09	1 Year

6.2. Limit

All the lower and upper band-edges emissions appearing within 2310MHz to 2390MHz and 2483.5MHz to 2500MHz restricted frequency bands shall not exceed the limits shown in 15.209, all the other emissions outside operation frequency band 2400MHz to 2483.5MHz shall be at least 20dB below the fundamental emissions, or comply with 15.209 limits.

6.3. Test Produce

1. The EUT is placed on a turntable, which is 0.8m above the ground plane and worked at highest radiated power.
2. The turntable was rotated for 360 degrees to determine the position of maximum emission level.
3. EUT is set 3m away from the receiving antenna, which is varied from 1m to 4m to find out the highest emission.
4. Set the spectrum analyzer in the following setting in order to capture the lower and upperband-edges of the emission:
 - (a) PEAK: RBW=VBW=1MHz / Sweep=AUTO
 - (b) AVERAGE: RBW=1MHz / VBW=10Hz / Sweep=AUTO

6.4. Test Results

Pass (The testing data was attached in the next pages.)

All the emissions outside operation frequency band were comply with 15.209 limit



No.6 Ke Feng Road,Block 52,
 ShenZhen Science & Industry Park
 Noutou,ShenZhen,GuangDong,China
 Tel:+86-755-26639495-7
 Fax:+86-755-26632877
 Postcode:518057

Data: 37 File: E:\2009 report data\TP-LINK\ACS9Q1514.EM6 (56)

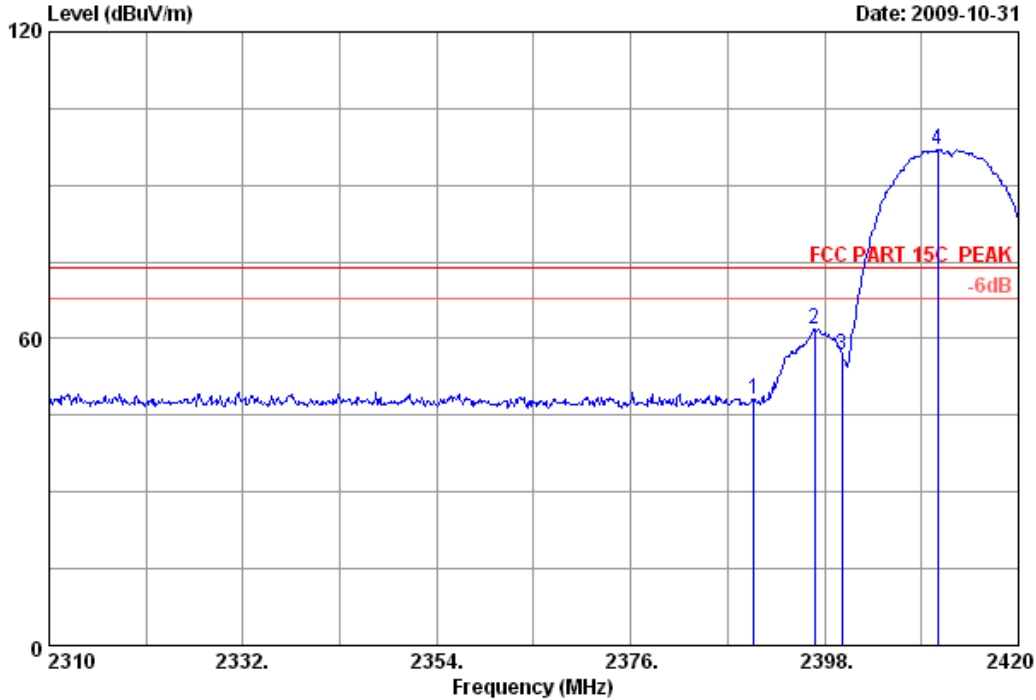

Site no. : 3m Chamber Data no. : 37
 Dis. / Ant. : 3m 3115(0905) Ant. pol. : HORIZONTAL
 Limit : FCC PART 15C PEAK
 Env. / Ins. : 23°C/54% Engineer : Sunny-lu
 EUT : 54M Wireless Router
 Power : DC 9V From Adapter Input AC 120V/60Hz
 Test mode : IEEE802.11b CH1 2412MHz Tx
 M/N : MRO-WR542G

	Ant.	Cable	Amp.	Emission					
Freq.	Factor	loss	Factor	Reading	Level	Limits	Margin	Remark	
(MHz)	(dB/m)	(dB)	(dB)	(dbuv)	(dBuV/m)	(dBuV/m)	(dB)		
1	2390.000	28.46	8.41	36.09	47.25	48.03	74.00	25.97	Peak
2	2396.900	28.46	8.41	36.09	61.17	61.95	74.00	12.05	Peak
3	2400.000	28.46	8.60	36.09	55.72	56.69	74.00	17.31	Peak
4	2410.870	28.48	8.60	35.95	95.75	96.88	74.00	-22.88	Peak

Remarks:

1. Emission Level= Antenna Factor + Cable Loss -Amp Factor + Reading.
2. The emission levels that are 20dB below the official limit are not reported.



No.6 Ke Feng Road,Block 52,
ShenZhen Science & Industry Park
Noutou, ShenZhen, GuangDong, China
Tel:+86-755-26639495-7
Fax:+86-755-26632877
Postcode:518057

Data: 38 File: E:\2009 report data\TP-LINK\ACS9Q1514.EM6 (56)

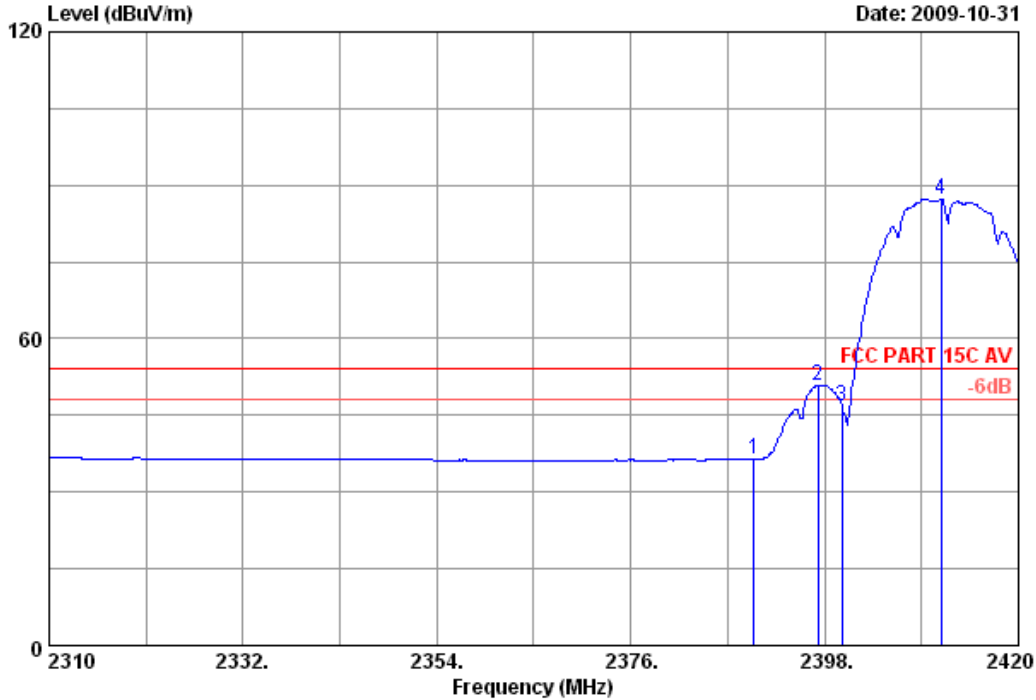

Site no. : 3m Chamber Data no. : 38
 Dis. / Ant. : 3m 3115(0905) Ant. pol. : HORIZONTAL
 Limit : FCC PART 15C AV
 Env. / Ins. : 23°C/54% Engineer : Sunny-lu
 EUT : 54M Wireless Router
 Power : DC 9V From Adapter Input AC 120V/60Hz
 Test mode : IEEE802.11b CH1 2412MHz Tx
 M/N : MRO-WR542G

	Freq. (MHz)	Ant. Factor (dB/m)	Cable loss (dB)	Amp. Factor (dB)	Reading (dbuv)	Emission			Remark
						Level (dBuV/m)	Limits (dBuV/m)	Margin (dB)	
1	2390.000	28.46	8.41	36.09	35.71	36.49	54.00	17.51	Average
2	2397.230	28.46	8.41	36.09	50.13	50.91	54.00	3.09	Average
3	2400.000	28.46	8.60	36.09	45.86	46.83	54.00	7.17	Average
4	2411.200	28.48	8.60	35.95	86.08	87.21	54.00	-33.21	Average

Remarks:

1. Emission Level= Antenna Factor + Cable Loss -Amp Factor + Reading.
2. The emission levels that are 20dB below the official limit are not reported.



No.6 Ke Feng Road,Block 52,
ShenZhen Science & Industry Park
Noutou,ShenZhen,GuangDong,China
Tel:+86-755-26639495-7
Fax:+86-755-26632877
Postcode:518057

Data: 39 File: E:\2009 report data\TP-LINK\ACS9Q1514.EM6 (56)

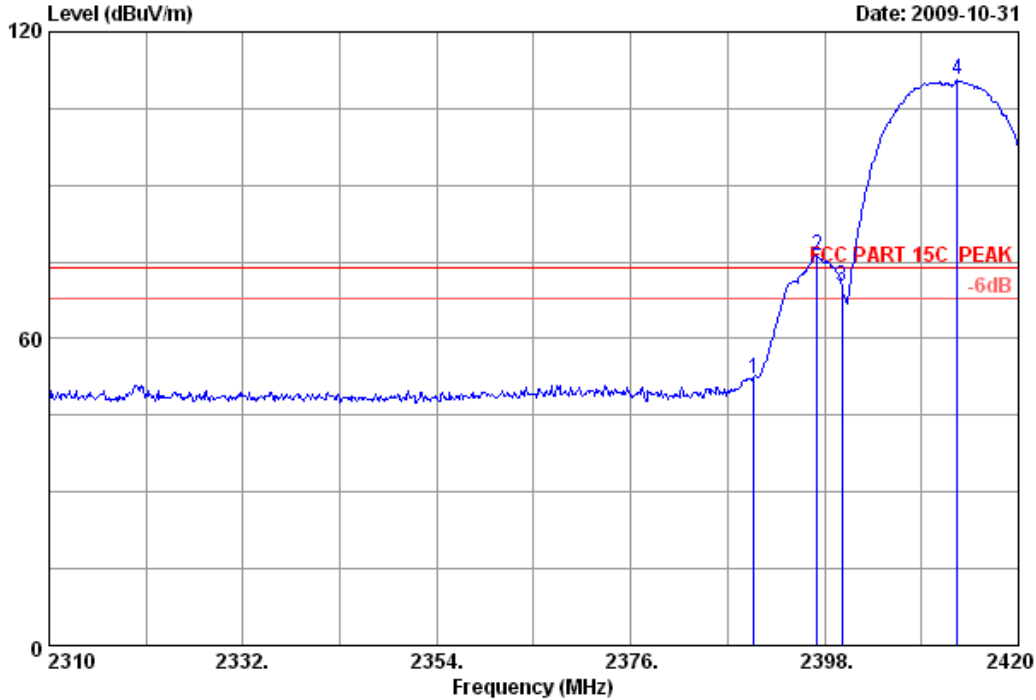

Site no. : 3m Chamber Data no. : 39
 Dis. / Ant. : 3m 3115(0905) Ant. pol. : VERTICAL
 Limit : FCC PART 15C PEAK
 Env. / Ins. : 23°C/54% Engineer : Sunny-lu
 EUT : 54M Wireless Router
 Power : DC 9V From Adapter Input AC 120V/60Hz
 Test mode : IEEE802.11b CH1 2412MHz Tx
 M/N : MRO-WR542G

	Ant. Freq. (MHz)	Factor (dB/m)	Cable loss (dB)	Amp. Factor (dB)	Reading (dbuv)	Emission Level (dBuV/m)	Limits (dBuV/m)	Margin (dB)	Remark
1	2390.000	28.46	8.41	36.09	51.47	52.25	74.00	21.75	Peak
2	2397.120	28.46	8.41	36.09	75.29	76.07	74.00	-2.07	Peak
3	2400.000	28.46	8.60	36.09	69.16	70.13	74.00	3.87	Peak
4	2413.070	28.48	8.60	35.95	109.35	110.48	74.00	-36.48	Peak

Remarks:

1. Emission Level= Antenna Factor + Cable Loss -Amp Factor + Reading.
2. The emission levels that are 20dB below the official limit are not reported.



No.6 Ke Feng Road,Block 52,
 ShenZhen Science & Industry Park
 Noutou,ShenZhen,GuangDong,China
 Tel:+86-755-26639495-7
 Fax:+86-755-26632877
 Postcode:518057

Data: 40 File: E:\2009 report data\TP-LINK\ACS9Q1514.EM6 (56)

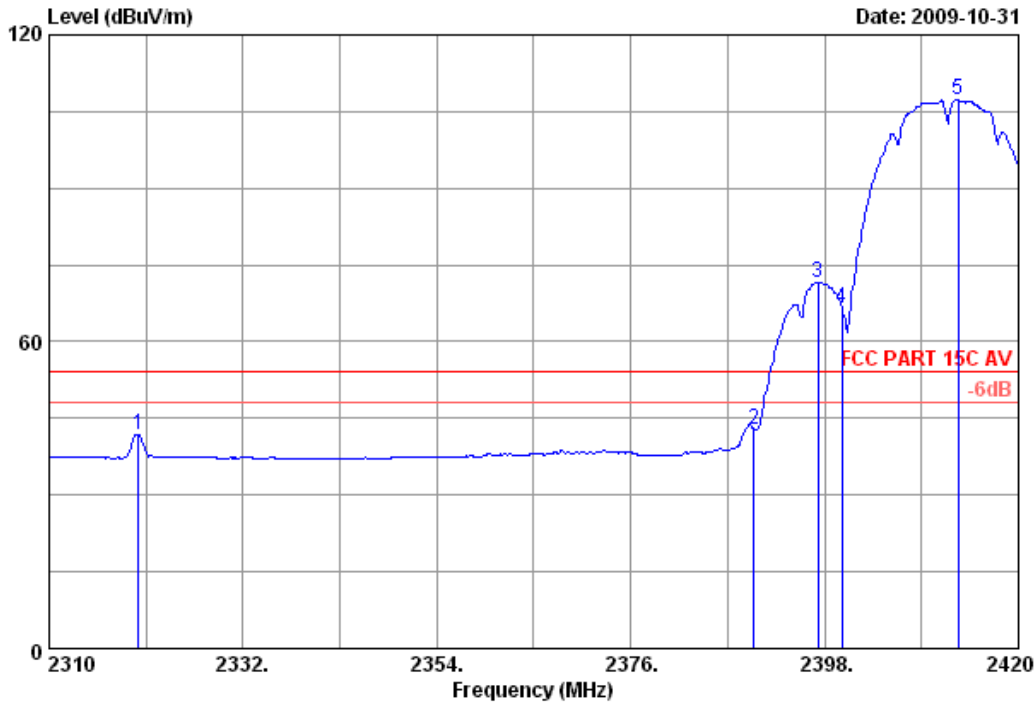

Site no. : 3m Chamber Data no. : 40
 Dis. / Ant. : 3m 3115(0905) Ant. pol. : VERTICAL
 Limit : FCC PART 15C AV
 Env. / Ins. : 23°C/54% Engineer : Sunny-lu
 EUT : 54M Wireless Router
 Power : DC 9V From Adapter Input AC 120V/60Hz
 Test mode : IEEE802.11b CH1 2412MHz Tx
 M/N : MRO-WR542G

	Freq. (MHz)	Ant. Factor (dB/m)	Cable loss (dB)	Amp. Factor (dB)	Reading (dbuv)	Emission			Remark
						Level (dBuV/m)	Limits (dBuV/m)	Margin (dB)	
1	2320.120	28.36	8.64	36.06	40.98	41.92	54.00	12.08	Average
2	2390.000	28.46	8.41	36.09	41.88	42.66	54.00	11.34	Average
3	2397.230	28.46	8.41	36.09	70.89	71.67	54.00	-17.67	Average
4	2400.000	28.46	8.60	36.09	65.61	66.58	54.00	-12.58	Average
5	2413.180	28.48	8.60	35.95	106.20	107.33	54.00	-53.33	Average

Remarks:

1. Emission Level= Antenna Factor + Cable Loss -Amp Factor + Reading.
2. The emission levels that are 20dB below the official limit are not reported.



No.6 Ke Feng Road,Block 52,
 ShenZhen Science & Industry Park
 Noutou,ShenZhen,GuangDong,China
 Tel:+86-755-26639495-7
 Fax:+86-755-26632877
 Postcode:518057

Data: 41 File: E:\2009 report data\TP-LINK\ACS9Q1514.EM6 (56)

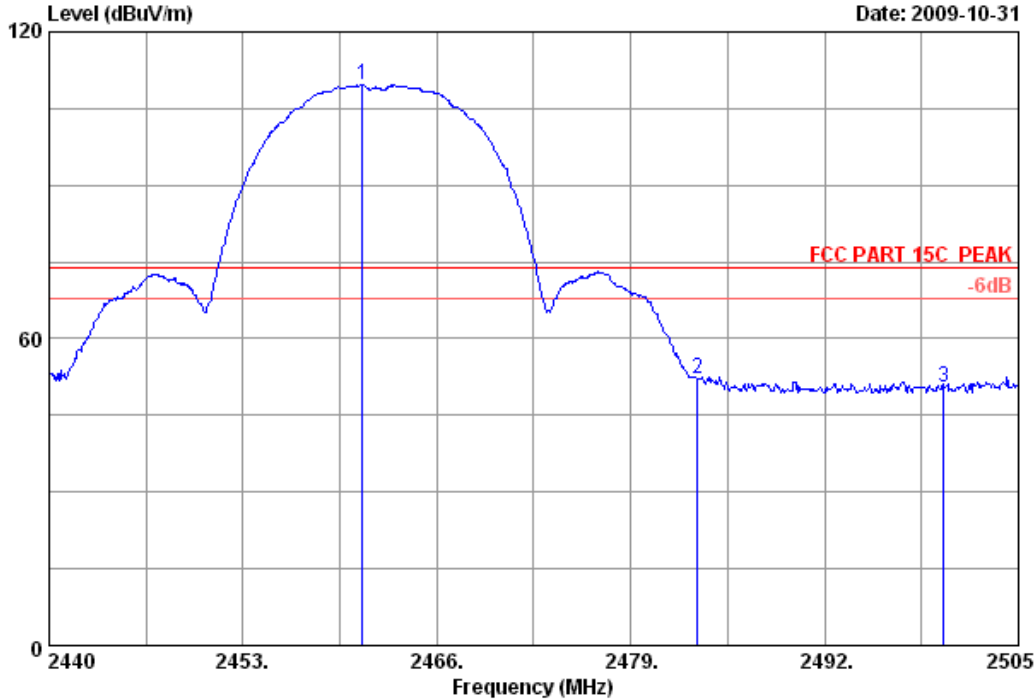

Site no. : 3m Chamber Data no. : 41
 Dis. / Ant. : 3m 3115(0905) Ant. pol. : VERTICAL
 Limit : FCC PART 15C PEAK
 Env. / Ins. : 23°C/54% Engineer : Sunny-lu
 EUT : 54M Wireless Router
 Power : DC 9V From Adapter Input AC 120V/60Hz
 Test mode : IEEE802.11b CH11 2462MHz Tx
 M/N : MRO-WR542G

	Ant. Freq. (MHz)	Factor (dB/m)	Cable loss (dB)	Amp. Factor (dB)	Reading (dbuv)	Emission Level (dBuV/m)	Limits (dBuV/m)	Margin (dB)	Remark
1	2460.995	28.55	8.76	36.02	108.36	109.65	74.00	-35.65	Peak
2	2483.500	28.58	8.94	35.97	50.52	52.07	74.00	21.93	Peak
3	2500.000	28.60	8.89	36.00	49.05	50.54	74.00	23.46	Peak

Remarks:

1. Emission Level= Antenna Factor + Cable Loss -Amp Factor + Reading.
2. The emission levels that are 20dB below the official limit are not reported.



No.6 Ke Feng Road,Block 52,
ShenZhen Science & Industry Park
Noutou,ShenZhen,GuangDong,China
Tel:+86-755-26639495-7
Fax:+86-755-26632877
Postcode:518057

Data: 42 File: E:\2009 report data\TP-LINK\ACS9Q1514.EM6 (56)

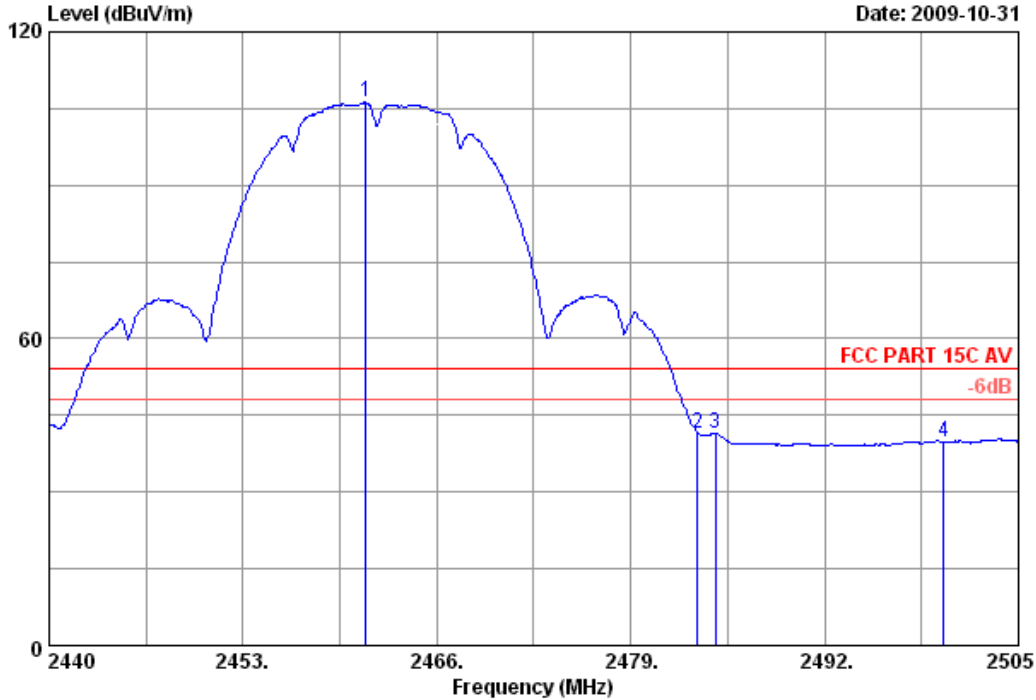

Site no. : 3m Chamber Data no. : 42
 Dis. / Ant. : 3m 3115(0905) Ant. pol. : VERTICAL
 Limit : FCC PART 15C AV
 Env. / Ins. : 23°C/54% Engineer : Sunny-lu
 EUT : 54M Wireless Router
 Power : DC 9V From Adapter Input AC 120V/60Hz
 Test mode : IEEE802.11b CH11 2462MHz Tx
 M/N : MRO-WR542G

	Freq. (MHz)	Ant. Factor (dB/m)	Cable loss (dB)	Amp. Factor (dB)	Reading (dbuv)	Emission		Margin (dB)	Remark
						Level (dBuV/m)	Limits (dBuV/m)		
1	2461.255	28.55	8.76	36.02	104.86	106.15	54.00	-52.15	Average
2	2483.500	28.58	8.94	35.97	40.03	41.58	54.00	12.42	Average
3	2484.655	28.58	8.94	35.97	39.98	41.53	54.00	12.47	Average
4	2500.000	28.60	8.89	36.00	38.31	39.80	54.00	14.20	Average

Remarks:

1. Emission Level= Antenna Factor + Cable Loss -Amp Factor + Reading.
2. The emission levels that are 20dB below the official limit are not reported.



No.6 Ke Feng Road,Block 52,
 ShenZhen Science & Industry Park
 Noutou,ShenZhen,GuangDong,China
 Tel:+86-755-26639495-7
 Fax:+86-755-26632877
 Postcode:518057

Data: 43 File: E:\2009 report data\TP-LINK\ACS9Q1514.EM6 (56)

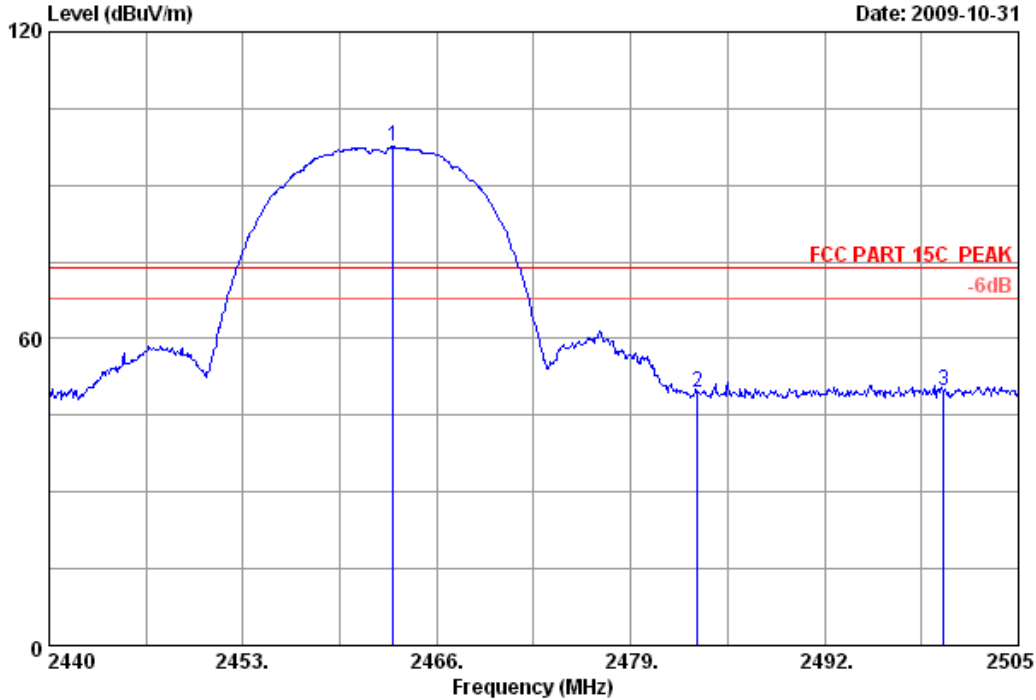

Site no. : 3m Chamber Data no. : 43
 Dis. / Ant. : 3m 3115(0905) Ant. pol. : HORIZONTAL
 Limit : FCC PART 15C PEAK
 Env. / Ins. : 23°C/54% Engineer : Sunny-lu
 EUT : 54M Wireless Router
 Power : DC 9V From Adapter Input AC 120V/60Hz
 Test mode : IEEE802.11b CH11 2462MHz Tx
 M/N : MRO-WR542G

	Ant.	Cable	Amp.	Emission					
Freq.	Factor	loss	Factor	Reading	Level	Limits	Margin	Remark	
(MHz)	(dB/m)	(dB)	(dB)	(dbuv)	(dBuV/m)	(dBuV/m)	(dB)		
1 2463.075	28.55	8.76	36.02	96.22	97.51	74.00	-23.51	Peak	
2 2483.500	28.58	8.94	35.97	48.03	49.58	74.00	24.42	Peak	
3 2500.000	28.60	8.89	36.00	48.31	49.80	74.00	24.20	Peak	

Remarks:

1. Emission Level= Antenna Factor + Cable Loss -Amp Factor + Reading.
2. The emission levels that are 20dB below the official limit are not reported.



No.6 Ke Feng Road,Block 52,
 ShenZhen Science & Industry Park
 Noutou,ShenZhen,GuangDong,China
 Tel:+86-755-26639495-7
 Fax:+86-755-26632877
 Postcode:518057

Data: 44 File: E:\2009 report data\TP-LINK\ACS9Q1514.EM6 (56)

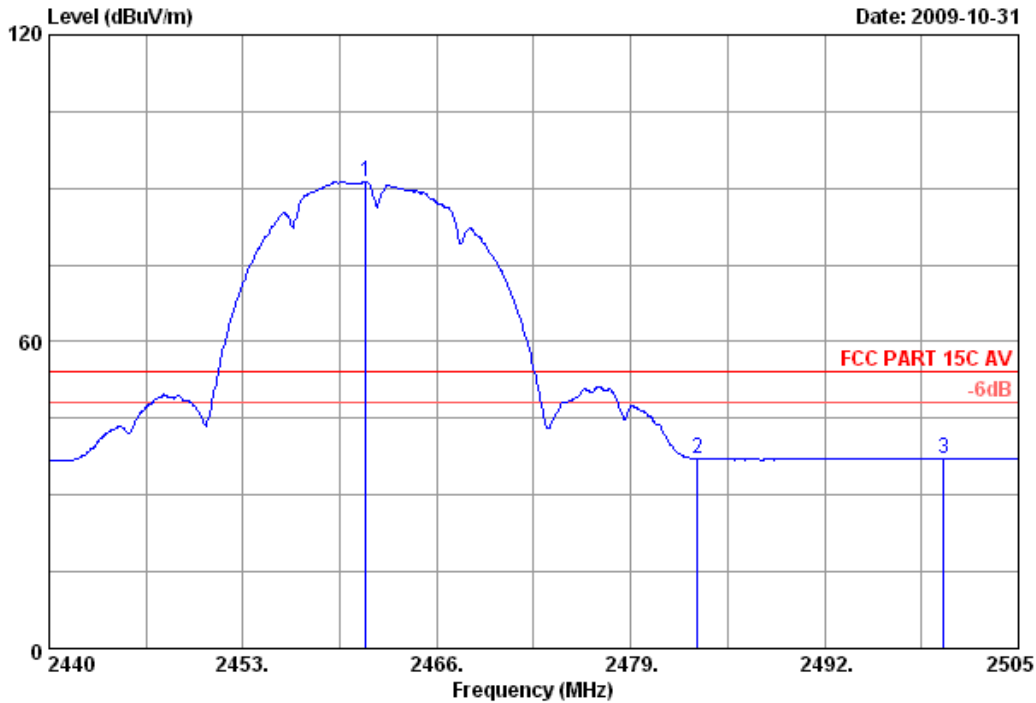

Site no. : 3m Chamber Data no. : 44
 Dis. / Ant. : 3m 3115(0905) Ant. pol. : HORIZONTAL
 Limit : FCC PART 15C AV
 Env. / Ins. : 23*C/54% Engineer : Sunny-lu
 EUT : 54M Wireless Router
 Power : DC 9V From Adapter Input AC 120V/60Hz
 Test mode : IEEE802.11b CH11 2462MHz Tx
 M/N : MRO-WR542G

	Ant. Freq. (MHz)	Factor (dB/m)	Cable loss (dB)	Amp. Factor (dB)	Reading (dbuv)	Emission Level (dBuV/m)	Limits (dBuV/m)	Margin (dB)	Remark
1	2461.255	28.55	8.76	36.02	89.99	91.28	54.00	-37.28	Average
2	2483.500	28.58	8.94	35.97	35.46	37.01	54.00	16.99	Average
3	2500.000	28.60	8.89	36.00	35.51	37.00	54.00	17.00	Average

Remarks:

1. Emission Level= Antenna Factor + Cable Loss -Amp Factor + Reading.
2. The emission levels that are 20dB below the official limit are not reported.



No.6 Ke Feng Road,Block 52,
 ShenZhen Science & Industry Park
 Noutou,ShenZhen,GuangDong,China
 Tel:+86-755-26639495-7
 Fax:+86-755-26632877
 Postcode:518057

Data: 45 File: E:\2009 report data\TP-LINK\ACS9Q1514.EM6 (56)

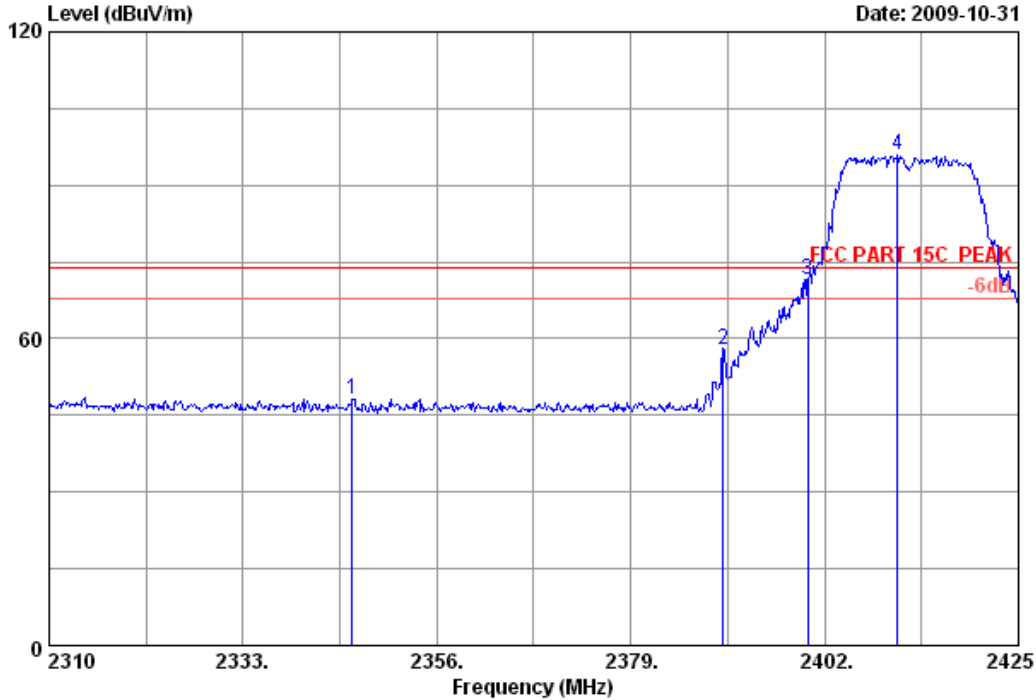

Site no. : 3m Chamber Data no. : 45
 Dis. / Ant. : 3m 3115(0905) Ant. pol. : HORIZONTAL
 Limit : FCC PART 15C PEAK
 Env. / Ins. : 23*C/54% Engineer : Sunny-lu
 EUT : 54M Wireless Router
 Power : DC 9V From Adapter Input AC 120V/60Hz
 Test mode : IEEE802.11g CH1 2412MHz Tx
 M/N : MRO-WR542G

	Ant. Freq. (MHz)	Factor (dB/m)	Cable loss (dB)	Amp. Factor (dB)	Reading (dbuv)	Emission Level (dBuV/m)	Limits (dBuV/m)	Margin (dB)	Remark
1	2345.995	28.38	8.57	35.99	47.27	48.23	74.00	25.77	Peak
2	2390.000	28.46	8.41	36.09	57.01	57.79	74.00	16.21	Peak
3	2400.000	28.46	8.60	36.09	70.52	71.49	74.00	2.51	Peak
4	2410.625	28.48	8.60	35.95	94.79	95.92	74.00	-21.92	Peak

Remarks:

1. Emission Level= Antenna Factor + Cable Loss -Amp Factor + Reading.
2. The emission levels that are 20dB below the official limit are not reported.



No.6 Ke Feng Road,Block 52,
 ShenZhen Science & Industry Park
 Noutou,ShenZhen,GuangDong,China
 Tel:+86-755-26639495-7
 Fax:+86-755-26632877
 Postcode:518057

Data: 46 File: E:\2009 report data\TP-LINK\ACS9Q1514.EM6 (56)

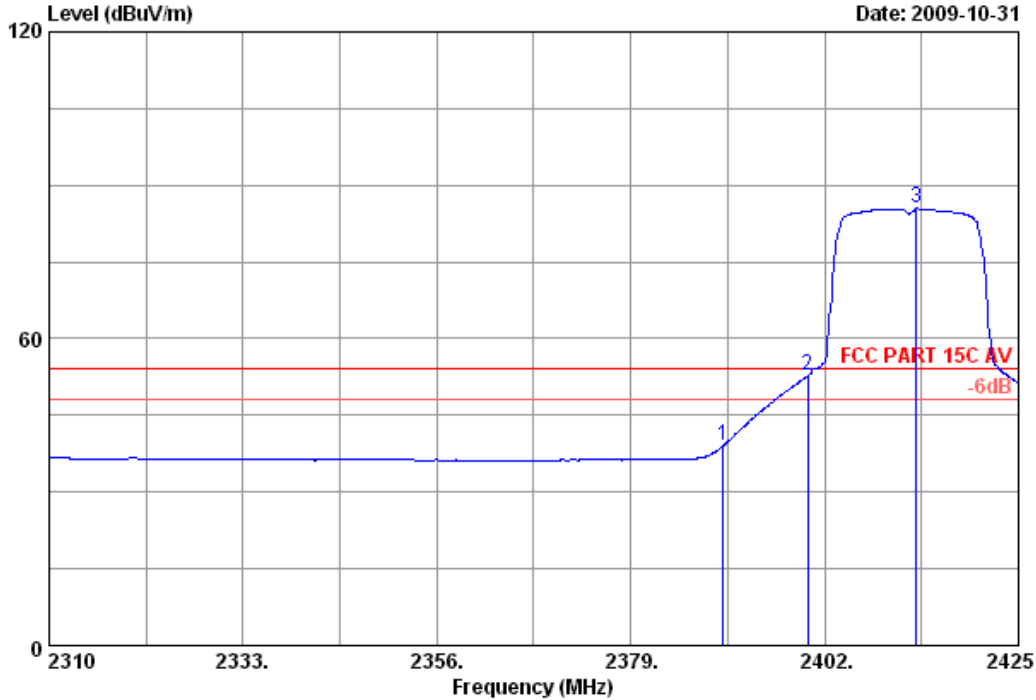

Site no. : 3m Chamber Data no. : 46
 Dis. / Ant. : 3m 3115(0905) Ant. pol. : HORIZONTAL
 Limit : FCC PART 15C AV
 Env. / Ins. : 23°C/54% Engineer : Sunny-lu
 EUT : 54M Wireless Router
 Power : DC 9V From Adapter Input AC 120V/60Hz
 Test mode : IEEE802.11g CH1 2412MHz Tx
 M/N : MRO-WR542G

	Ant. Freq. (MHz)	Factor (dB/m)	Cable loss (dB)	Amp. Factor (dB)	Reading (dbuv)	Emission Level (dBuV/m)	Limits (dBuV/m)	Margin (dB)	Remark
1	2390.000	28.46	8.41	36.09	38.43	39.21	54.00	14.79	Average
2	2400.000	28.46	8.60	36.09	51.99	52.96	54.00	1.04	Average
3	2412.925	28.48	8.60	35.95	84.35	85.48	54.00	-31.48	Average

Remarks:

1. Emission Level= Antenna Factor + Cable Loss -Amp Factor + Reading.
2. The emission levels that are 20dB below the official limit are not reported.



No.6 Ke Feng Road,Block 52,
ShenZhen Science & Industry Park
Noutou,ShenZhen,GuangDong,China
Tel:+86-755-26639495-7
Fax:+86-755-26632877
Postcode:518057

Data: 47 File: E:\2009 report data\TP-LINK\ACS9Q1514.EM6 (56)

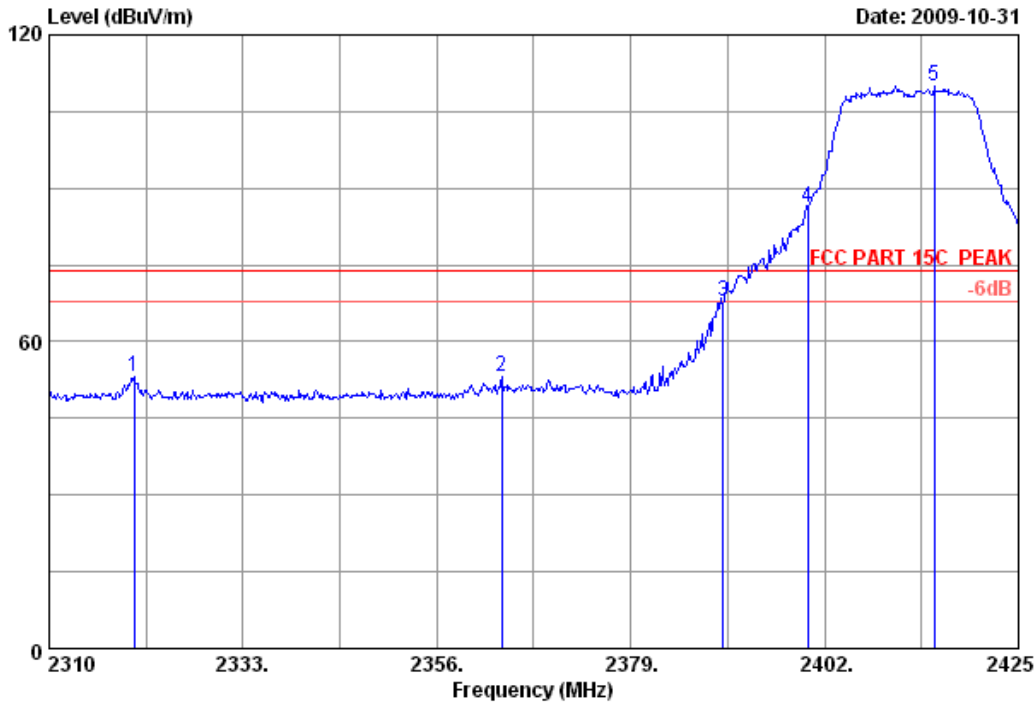

Site no. : 3m Chamber Data no. : 47
 Dis. / Ant. : 3m 3115(0905) Ant. pol. : VERTICAL
 Limit : FCC PART 15C PEAK
 Env. / Ins. : 23*C/54% Engineer : Sunny-lu
 EUT : 54M Wireless Router
 Power : DC 9V From Adapter Input AC 120V/60Hz
 Test mode : IEEE802.11g CH1 2412MHz Tx
 M/N : MRO-WR542G

	Freq. (MHz)	Ant. Factor (dB/m)	Cable loss (dB)	Amp. Factor (dB)	Reading (dbuv)	Emission Level (dBuV/m)	Limits (dBuV/m)	Margin (dB)	Remark
1	2320.120	28.36	8.64	36.06	52.18	53.12	74.00	20.88	Peak
2	2363.705	28.41	8.44	35.91	52.29	53.23	74.00	20.77	Peak
3	2390.000	28.46	8.41	36.09	67.22	68.00	74.00	6.00	Peak
4	2400.000	28.46	8.60	36.09	85.18	86.15	74.00	-12.15	Peak
5	2414.995	28.48	8.60	35.95	108.95	110.08	74.00	-36.08	Peak

Remarks:

1. Emission Level= Antenna Factor + Cable Loss -Amp Factor + Reading.
2. The emission levels that are 20dB below the official limit are not reported.



No.6 Ke Feng Road,Block 52,
ShenZhen Science & Industry Park
Noutou,ShenZhen,GuangDong,China
Tel:+86-755-26639495-7
Fax:+86-755-26632877
Postcode:518057

Data: 48 File: E:\2009 report data\TP-LINK\ACS9Q1514.EM6 (56)

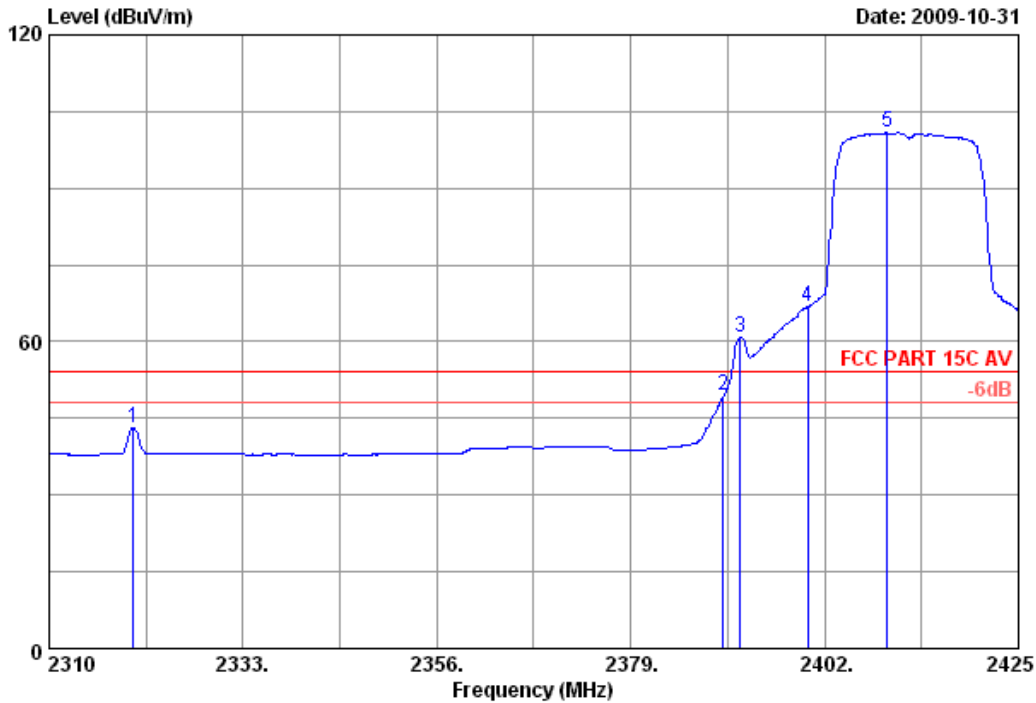

Site no. : 3m Chamber Data no. : 48
 Dis. / Ant. : 3m 3115(0905) Ant. pol. : VERTICAL
 Limit : FCC PART 15C AV
 Env. / Ins. : 23°C/54% Engineer : Sunny-lu
 EUT : 54M Wireless Router
 Power : DC 9V From Adapter Input AC 120V/60Hz
 Test mode : IEEE802.11g CH1 2412MHz Tx
 M/N : MRO-WR542G

	Freq. (MHz)	Ant. Factor (dB/m)	Cable loss (dB)	Amp. Factor (dB)	Reading (dbuv)	Emission			Remark
						Level (dBuV/m)	Limits (dBuV/m)	Margin (dB)	
1	2320.005	28.36	8.64	36.06	42.24	43.18	54.00	10.82	Average
2	2390.000	28.46	8.41	36.09	48.62	49.40	54.00	4.60	Average
3	2391.995	28.46	8.41	36.09	60.10	60.88	54.00	-6.88	Average
4	2400.000	28.46	8.60	36.09	65.82	66.79	54.00	-12.79	Average
5	2409.475	28.48	8.60	35.95	99.70	100.83	54.00	-46.83	Average

Remarks:

1. Emission Level= Antenna Factor + Cable Loss -Amp Factor + Reading.
2. The emission levels that are 20dB below the official limit are not reported.



No.6 Ke Feng Road,Block 52,
ShenZhen Science & Industry Park
Noutou, ShenZhen, GuangDong, China
Tel:+86-755-26639495-7
Fax:+86-755-26632877
Postcode:518057

Data: 49 File: E:\2009 report data\TP-LINK\ACS9Q1514.EM6 (56)

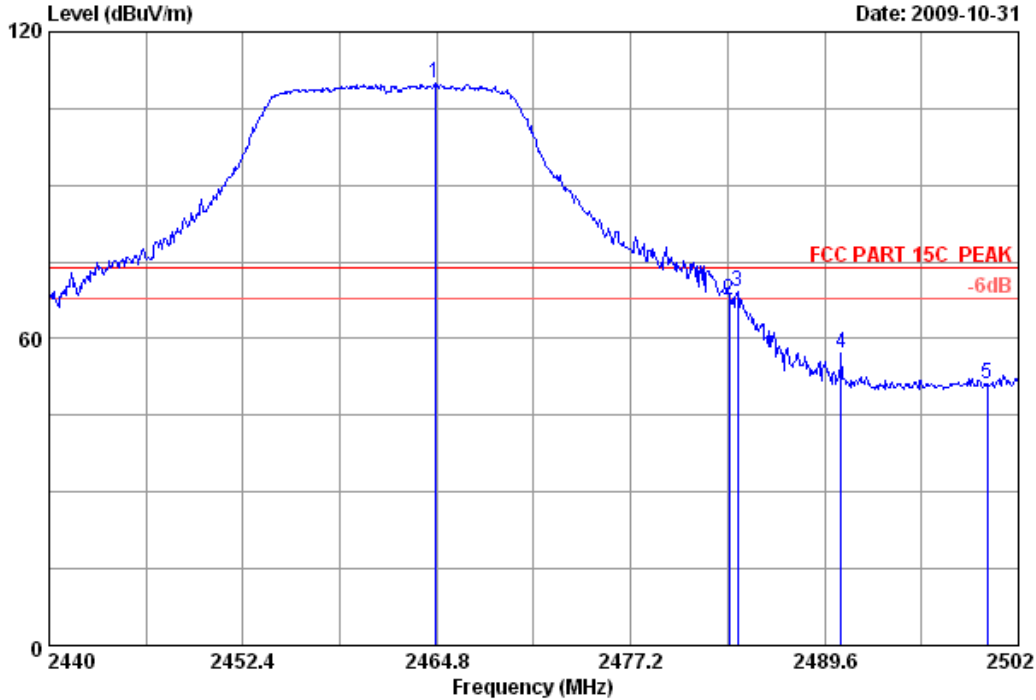

Site no. : 3m Chamber Data no. : 49
 Dis. / Ant. : 3m 3115(0905) Ant. pol. : VERTICAL
 Limit : FCC PART 15C PEAK
 Env. / Ins. : 23°C/54% Engineer : Sunny-lu
 EUT : 54M Wireless Router
 Power : DC 9V From Adapter Input AC 120V/60Hz
 Test mode : IEEE802.11g CH11 2462MHz Tx
 M/N : MRO-WR542G

	Freq. (MHz)	Ant. Factor (dB/m)	Cable loss (dB)	Amp. Factor (dB)	Reading (dbuv)	Emission Level (dBuV/m)	Limits (dBuV/m)	Margin (dB)	Remark
1	2464.676	28.55	8.76	36.02	108.74	110.03	74.00	-36.03	Peak
2	2483.500	28.58	8.94	35.97	66.01	67.56	74.00	6.44	Peak
3	2484.020	28.58	8.94	35.97	67.56	69.11	74.00	4.89	Peak
4	2490.654	28.60	8.94	36.00	55.49	57.03	74.00	16.97	Peak
5	2500.000	28.60	8.89	36.00	49.58	51.07	74.00	22.93	Peak

Remarks:

1. Emission Level= Antenna Factor + Cable Loss -Amp Factor + Reading.
2. The emission levels that are 20dB below the official limit are not reported.



No.6 Ke Feng Road,Block 52,
 ShenZhen Science & Industry Park
 Noutou,ShenZhen,GuangDong,China
 Tel:+86-755-26639495-7
 Fax:+86-755-26632877
 Postcode:518057

Data: 50 File: E:\2009 report data\TP-LINK\ACS9Q1514.EM6 (56)

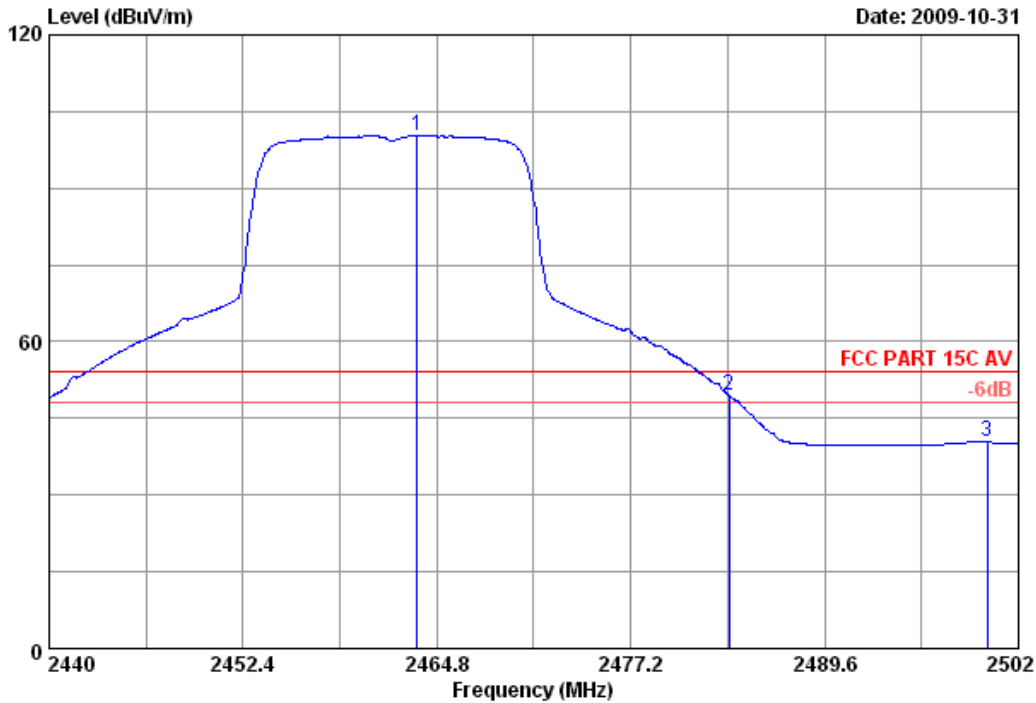

Site no. : 3m Chamber Data no. : 50
 Dis. / Ant. : 3m 3115(0905) Ant. pol. : VERTICAL
 Limit : FCC PART 15C AV
 Env. / Ins. : 23°C/54% Engineer : Sunny-lu
 EUT : 54M Wireless Router
 Power : DC 9V From Adapter Input AC 120V/60Hz
 Test mode : IEEE802.11g CH11 2462MHz Tx
 M/N : MRO-WR542G

	Ant. Freq. (MHz)	Factor (dB/m)	Cable loss (dB)	Amp. Factor (dB)	Reading (dbuv)	Emission Level (dBuV/m)	Limits (dBuV/m)	Margin (dB)	Remark
1	2463.560	28.55	8.76	36.02	98.97	100.26	54.00	-46.26	Average
2	2483.500	28.58	8.94	35.97	47.91	49.46	54.00	4.54	Average
3	2500.000	28.60	8.89	36.00	38.80	40.29	54.00	13.71	Average

Remarks:

1. Emission Level= Antenna Factor + Cable Loss -Amp Factor + Reading.
2. The emission levels that are 20dB below the official limit are not reported.



No.6 Ke Feng Road,Block 52,
ShenZhen Science & Industry Park
Noutou,ShenZhen,GuangDong,China
Tel:+86-755-26639495-7
Fax:+86-755-26632877
Postcode:518057

Data: 51 File: E:\2009 report data\TP-LINK\ACS9Q1514.EM6 (56)

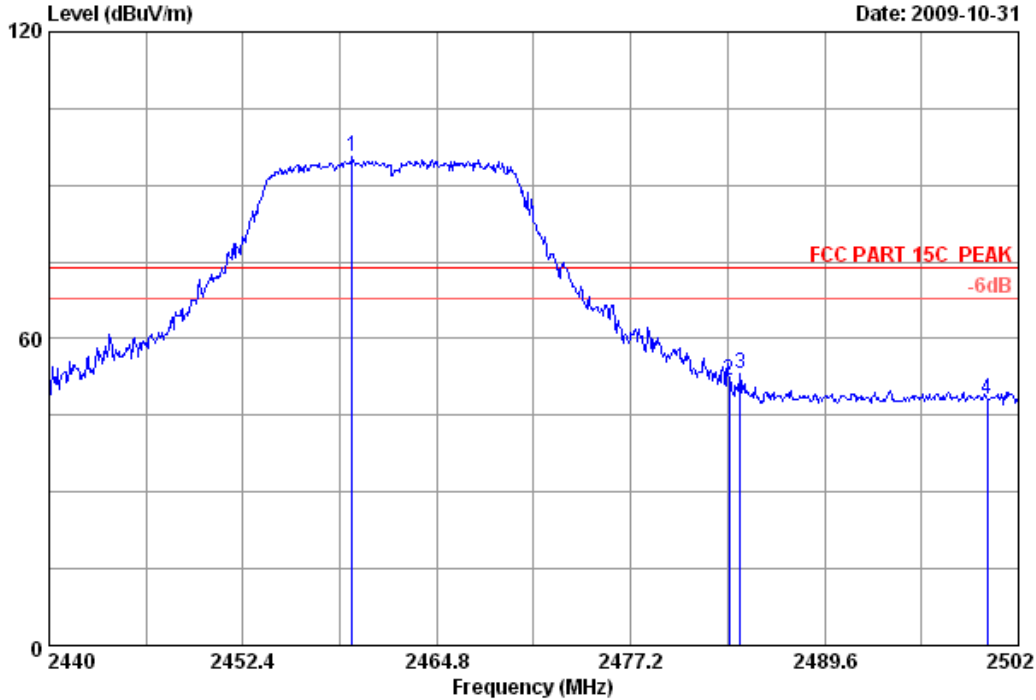

Site no. : 3m Chamber Data no. : 51
 Dis. / Ant. : 3m 3115(0905) Ant. pol. : HORIZONTAL
 Limit : FCC PART 15C PEAK
 Env. / Ins. : 23°C/54% Engineer : Sunny-lu
 EUT : 54M Wireless Router
 Power : DC 9V From Adapter Input AC 120V/60Hz
 Test mode : IEEE802.11g CH11 2462MHz Tx
 M/N : MRO-WR542G

	Freq. (MHz)	Ant. Factor (dB/m)	Cable loss (dB)	Amp. Factor (dB)	Reading (dbuv)	Emission Level (dBUV/m)	Limits (dBUV/m)	Margin (dB)	Remark
1	2459.406	28.55	8.76	36.02	94.33	95.62	74.00	-21.62	Peak
2	2483.500	28.58	8.94	35.97	50.42	51.97	74.00	22.03	Peak
3	2484.206	28.58	8.94	35.97	51.55	53.10	74.00	20.90	Peak
4	2500.000	28.60	8.89	36.00	46.76	48.25	74.00	25.75	Peak

Remarks:

1. Emission Level= Antenna Factor + Cable Loss -Amp Factor + Reading.
2. The emission levels that are 20dB below the official limit are not reported.



No.6 Ke Feng Road,Block 52,
 ShenZhen Science & Industry Park
 Noutou,ShenZhen,GuangDong,China
 Tel:+86-755-26639495-7
 Fax:+86-755-26632877
 Postcode:518057

Data: 52 File: E:\2009 report data\TP-LINK\ACS9Q1514.EM6 (56)

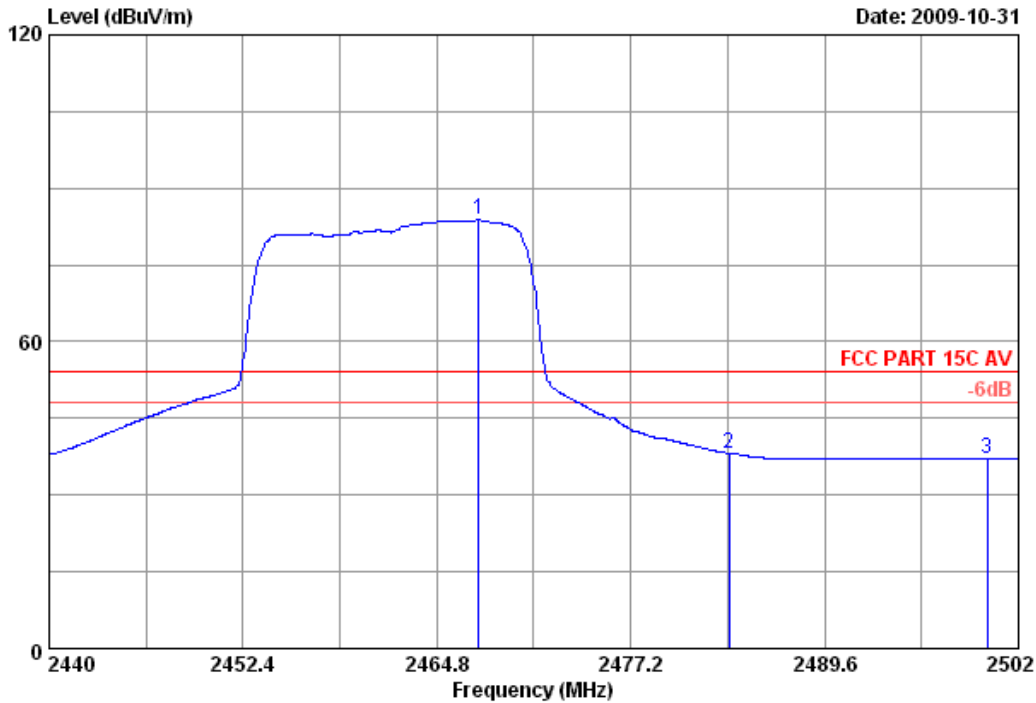

Site no. : 3m Chamber Data no. : 52
 Dis. / Ant. : 3m 3115(0905) Ant. pol. : HORIZONTAL
 Limit : FCC PART 15C AV
 Env. / Ins. : 23°C/54% Engineer : Sunny-lu
 EUT : 54M Wireless Router
 Power : DC 9V From Adapter Input AC 120V/60Hz
 Test mode : IEEE802.11g CH11 2462MHz Tx
 M/N : MRO-WR542G

	Ant. Freq. (MHz)	Factor (dB/m)	Cable loss (dB)	Amp. Factor (dB)	Reading (dbuv)	Emission Level (dBuV/m)	Limits (dBuV/m)	Margin (dB)	Remark
1	2467.466	28.55	8.76	36.02	82.58	83.87	54.00	-29.87	Average
2	2483.500	28.58	8.94	35.97	36.61	38.16	54.00	15.84	Average
3	2500.000	28.60	8.89	36.00	35.47	36.96	54.00	17.04	Average

Remarks:

1. Emission Level= Antenna Factor + Cable Loss -Amp Factor + Reading.
2. The emission levels that are 20dB below the official limit are not reported.

7. 6dB Bandwidth Test

7.1. Test Equipment

Item	Equipment	Manufacturer	Model No.	Serial No.	Last Cal.	Cal. Interval
1.	Spectrum Analyzer	Agilent	E4446A	US44300459	May.08, 09	1 Year
2.	Attenuator	Agilent	8491B	MY39262165	May.08, 09	1 Year
3.	RF Cable	Hubersuhner	SUCOFLEX 102	28618/2	May.08, 09	1 Year

7.2. Limit

For direct sequence systems, the minimum 6dB bandwidth shall be at least 500kHz

7.3. Test Procedure

The transmitter output was connected to a spectrum analyzer, The bandwidth of the fundamental frequency was measured by spectrum analyzer with 100kHz RBW and 100 kHz VBW. The 6dB bandwidth is defined as the total spectrum the power of which is higher than peak power minus 6dB.

7.4. Test Results

Test Mode: IEEE 802.11b TX

CH	6dB Bandwidth (MHz)	Limit	Conclusion
1	12.0	>500	PASS
6	12.5	>500	PASS
11	12.0	>500	PASS

Test Mode: IEEE 802.11g TX

CH	6dB Bandwidth (MHz)	Limit	Conclusion
1	16.3	>500	PASS
6	16.5	>500	PASS
11	16.5	>500	PASS

Test Mode: IEEE 802.11b TX

Test CH1: 2412MHz

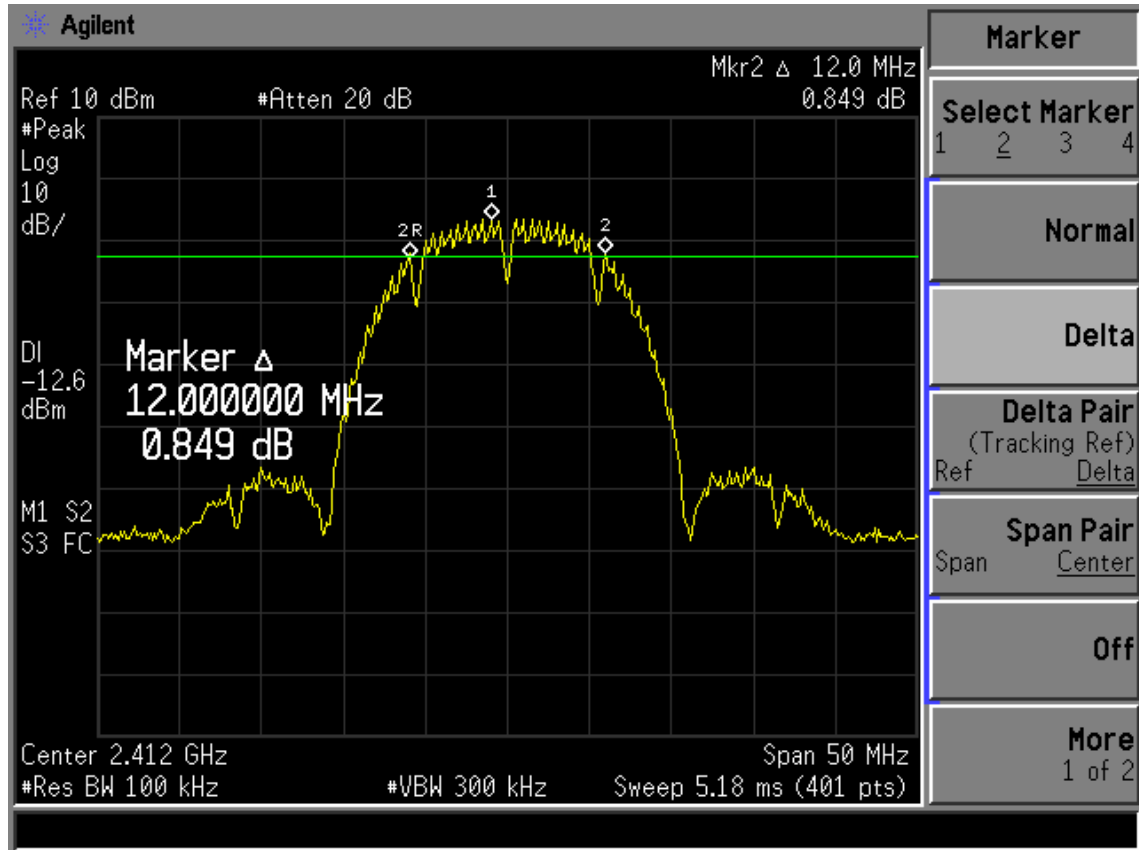

Test CH6: 2437MHz

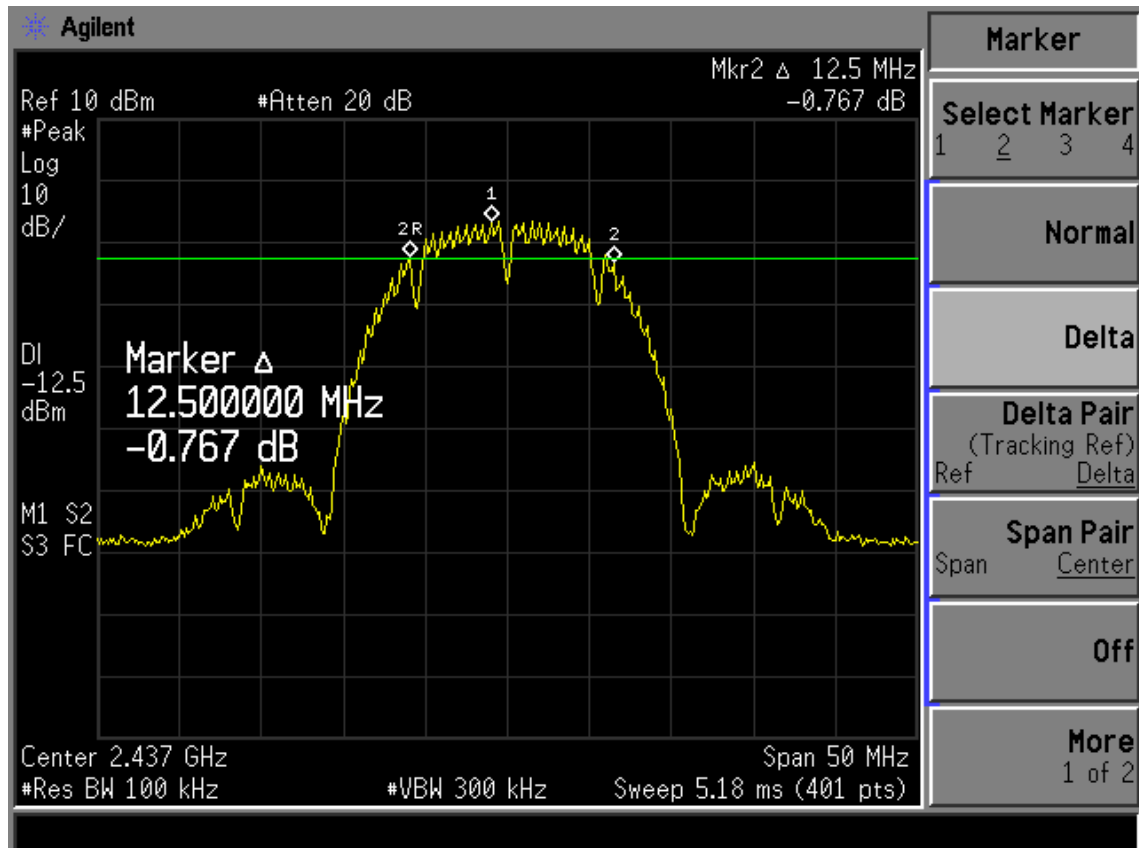

Test CH1: 2462MHz

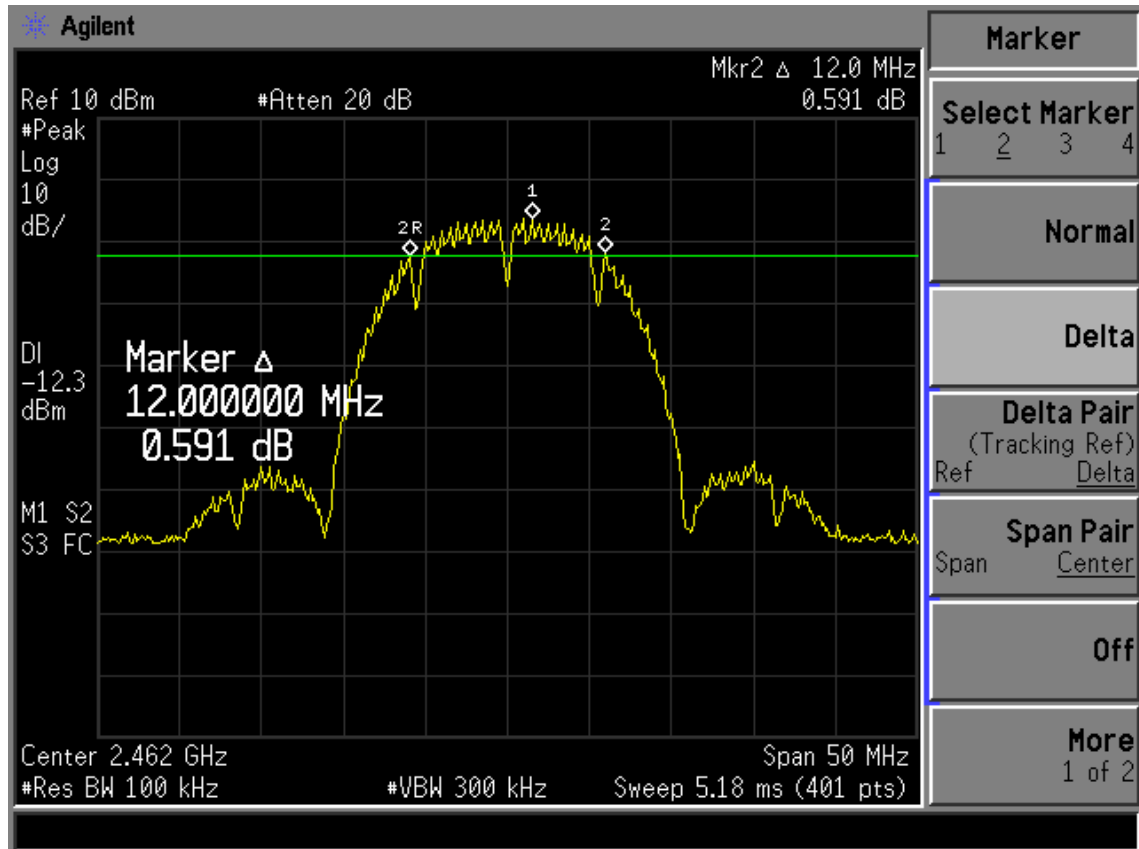

Test Mode: IEEE 802.11g TX

Test CH1: 2412MHz

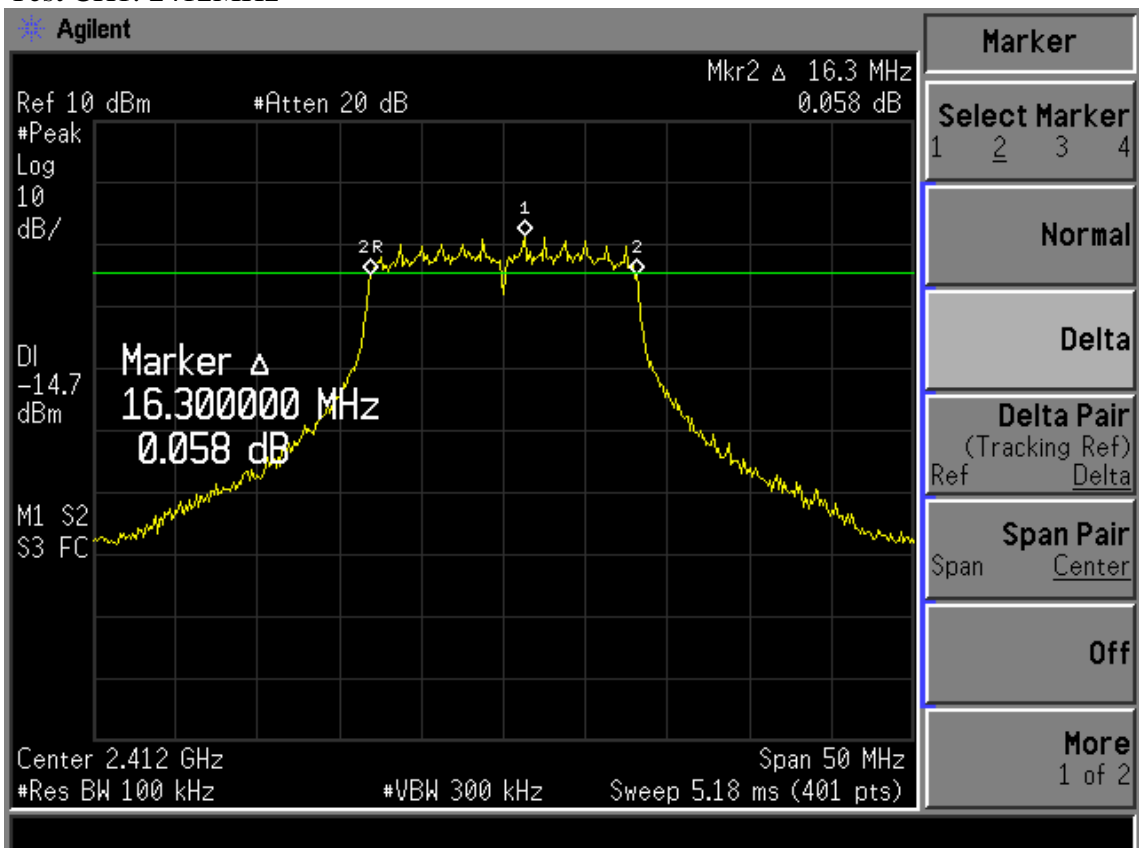

Test CH6: 2437MHz

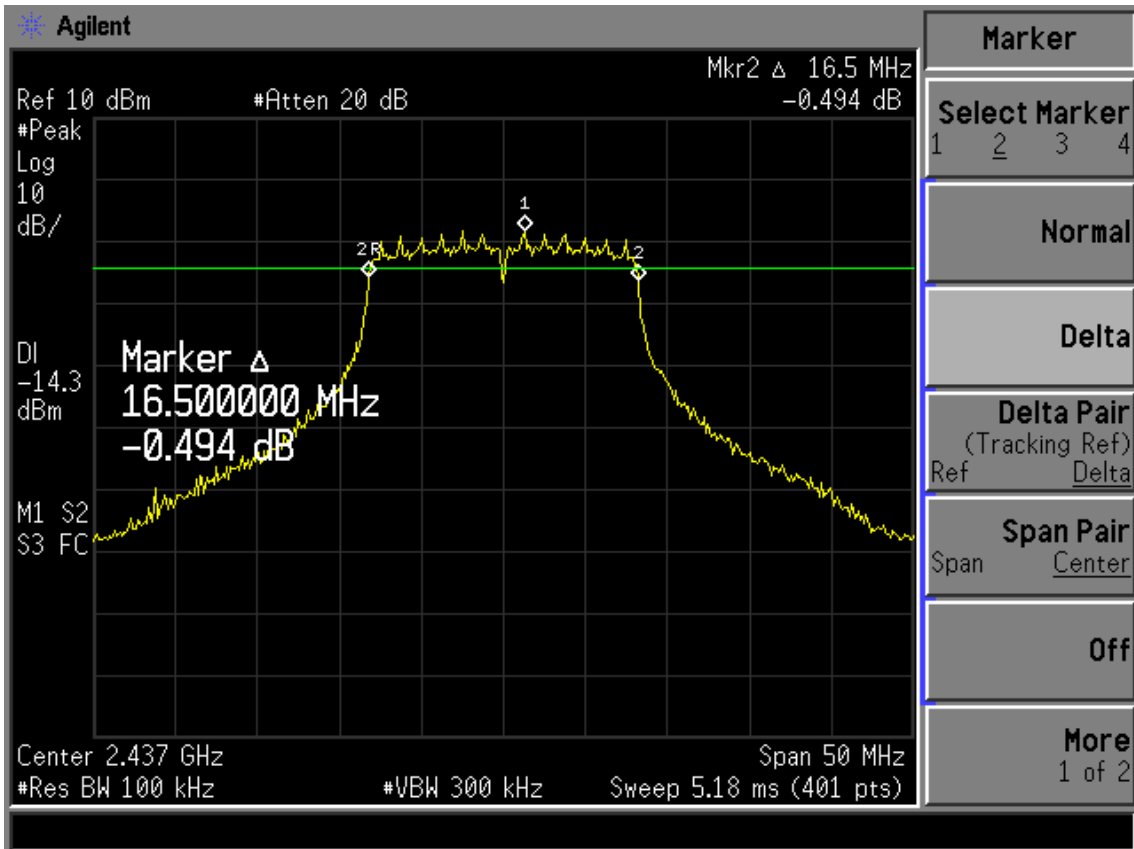

Test CH11: 2462MHz

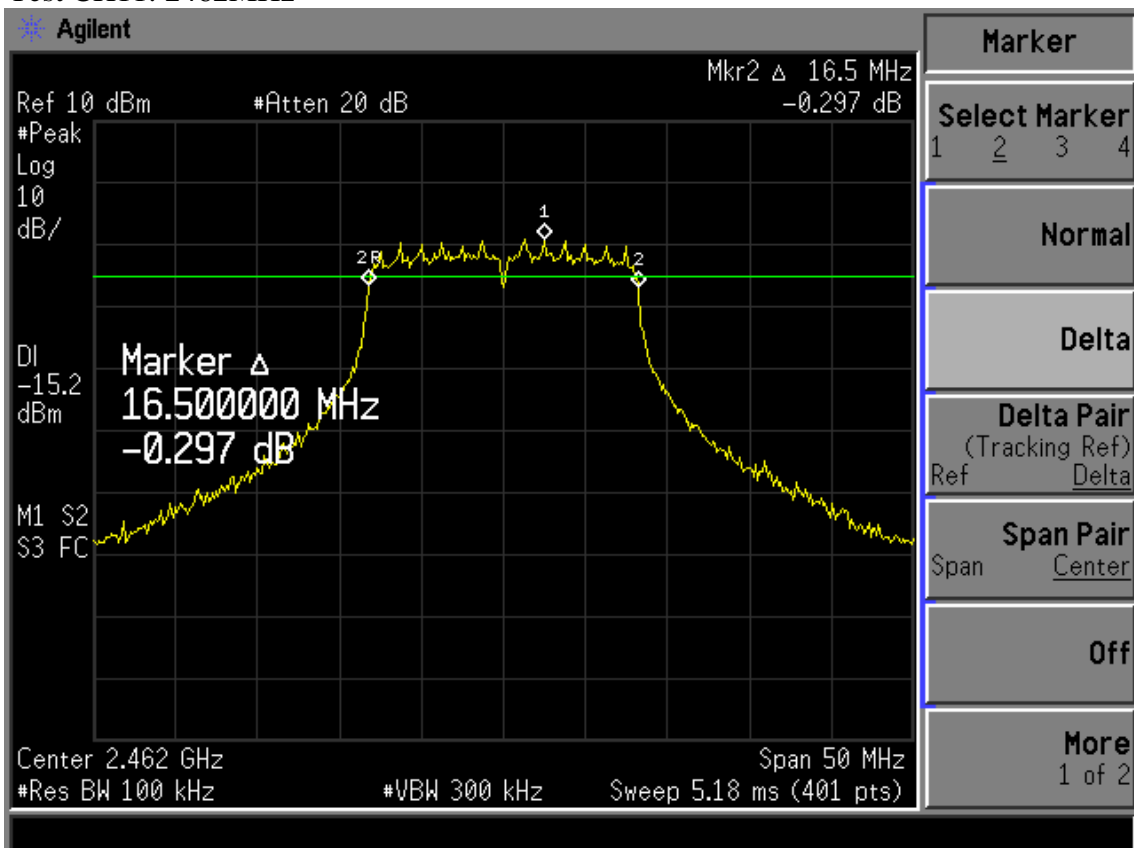

8. OUTPUT POWER TEST

8.1. Test Equipment

Item	Equipment	Manufacturer	Model No.	Serial No.	Last Cal.	Cal. Interval
1.	Power meter	Anritsu	ML2487A	6K00002472	Oct.20.09	1 Year
2	Power sensor	Anritsu	MA2491A	0033005	Oct.20.09	1 Year
2.	Attenuator	Agilent	8491B	MY39262165	May.08, 09	1 Year
3.	RF Cable	Hubersuhner	SUCOFLEX 102	28618/2	May.08, 09	1 Year

8.2. Limit(FCC Part 15C 15.247 b(3))

For systems using digital modulation in the 2400—2483.5MHz, The Peak out put Power shall not exceed 1W(30dBm)

8.3. Test Procedure

Use power output option 1 method of KDB 558074, the transmitter output was connection to a power meter by suitable attenuation, read out the peak output power of device.

8.4. Test Results

EUT: 54M Wireless Router M/N: MR0-WR542G							
Power: DC 9V From Adapter input AC 120V/60Hz							
Data Rate: 11b 1Mbps ; 11g 6Mbps ; (Note 1)							
Ambient Temperature: 26°C				Relative Humidity: 62%			
Test date: 2009/11/04				Test site: RF site		Tested by: Sunny lu	
Test CH	CH1 2412MHz CH6 2437MHz CH11 2462MHz						
Mode	CH	PK Read (dBm)	Cable Loss (dB)	Attenuator (dB)	Result (dBm)	Limit (dBm)	Conclusion
11b	CH1	6.42	0.60	10.0	17.02	30.00	PASS
	CH6	6.75	0.60	10.0	17.35	30.00	PASS
	CH11	6.66	0.60	10.0	17.26	30.00	PASS
11g	CH1	11.26	0.60	10.0	21.86	30.00	PASS
	CH6	11.96	0.60	10.0	22.56	30.00	PASS
	CH11	11.24	0.60	10.0	21.84	30.00	PASS
Note1: According Exploratory test, These data rate have the maximum output power							
Note2: Result= PK read +cable loss +Attenuator							

9. POWER SPECTRAL DENSITY TEST

9.1. Test Equipment

Item	Equipment	Manufacturer	Model No.	Serial No.	Last Cal.	Cal. Interval
1.	Spectrum Analyzer	Agilent	E4446A	US44300459	May.08, 09	1 Year
2.	Attenuator	Agilent	8491B	MY39262165	May.08, 09	1 Year
3.	RF Cable	Hubersuhner	SUCOFLEX 102	28618/2	May.08, 09	1 Year

9.2. Limit

For digitally modulated systems, the power spectral density conducted from the intentional radiator to the antenna shall not be greater than 8dBm in any 3kHz band during any time interval of continuous transmission.

9.3. Test Procedure

The transmitter output was connected to a spectrum analyzer. Power density was measured by spectrum analyzer with 3kHz RBW and 30kHz VBW, sweep time=span/3kHz.

9.4.Test Results

EUT: 54M Wireless Router M/N: MR0-WR542G							
Power: DC 9V From Adapter input AC 120V/60Hz							
Data Rate:11b: 1Mbps ; 11g : 6Mbps (Note 1)							
Ambient Temperature:25°C				Relative Humidity: 62%			
Test date:2009/11/04			Test site: RF site		Tested By: Sunny lu		
Test CH	CH1:2412MHz CH6:2437MHz CH11:2462MHz						
Mode	CH	Read (dBm)	Attenuator (dBm)	Cable loss (dBm)	Result (dBm)	Limit (dBm)	Conclusion
11b	CH1	-19.33	10.0	0.6	-8.73	8.00	PASS
	CH6	-18.92	10.0	0.6	-8.32	8.00	PASS
	CH11	-19.78	10.0	0.6	-9.18	8.00	PASS
11g	CH1	-22.34	10.0	0.6	-11.74	8.00	PASS
	CH6	-21.06	10.0	0.6	-10.46	8.00	PASS
	CH11	-22.09	10.0	0.6	-11.49	8.00	PASS
Note1:According Exploratory test, These data rate have the maximum output power							
Note2 : Result = Read + Attenuator + Cable loss							

Test Mode: IEEE 802.11b TX

Test CH1: 2412MHz

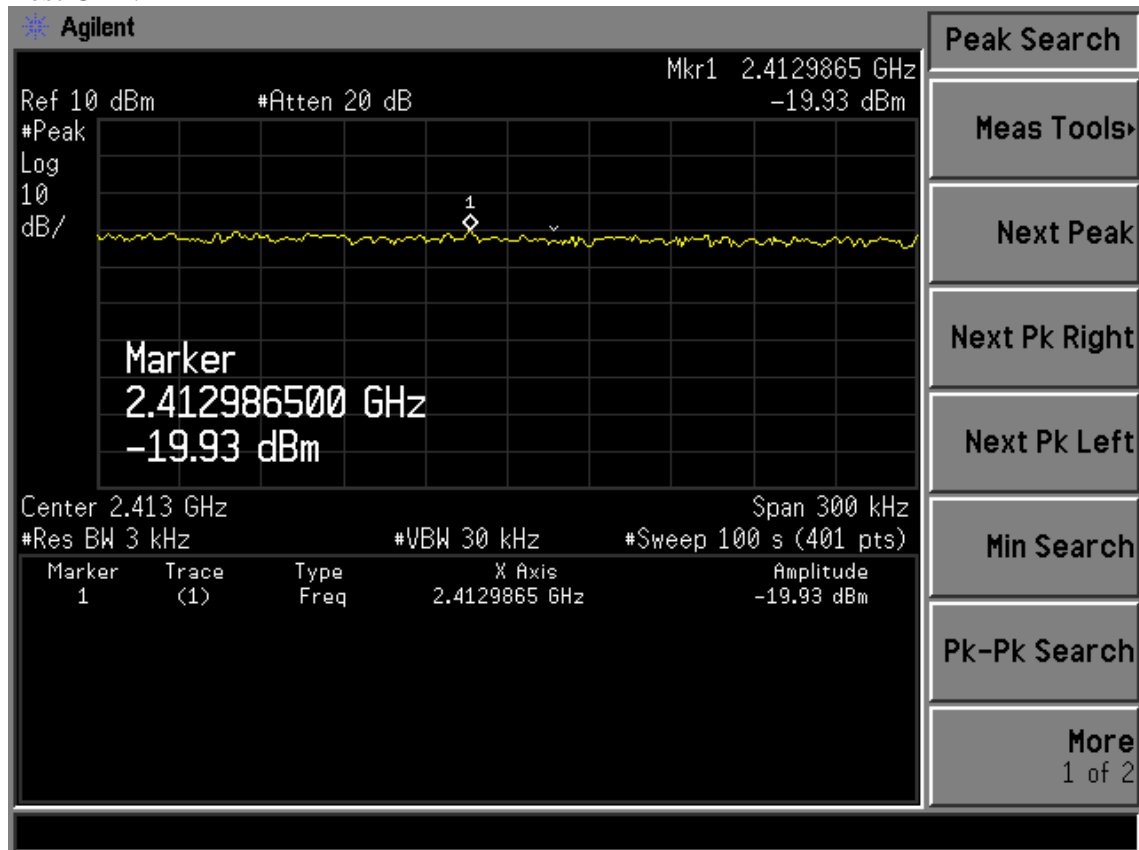

Test CH6: 2437MHz

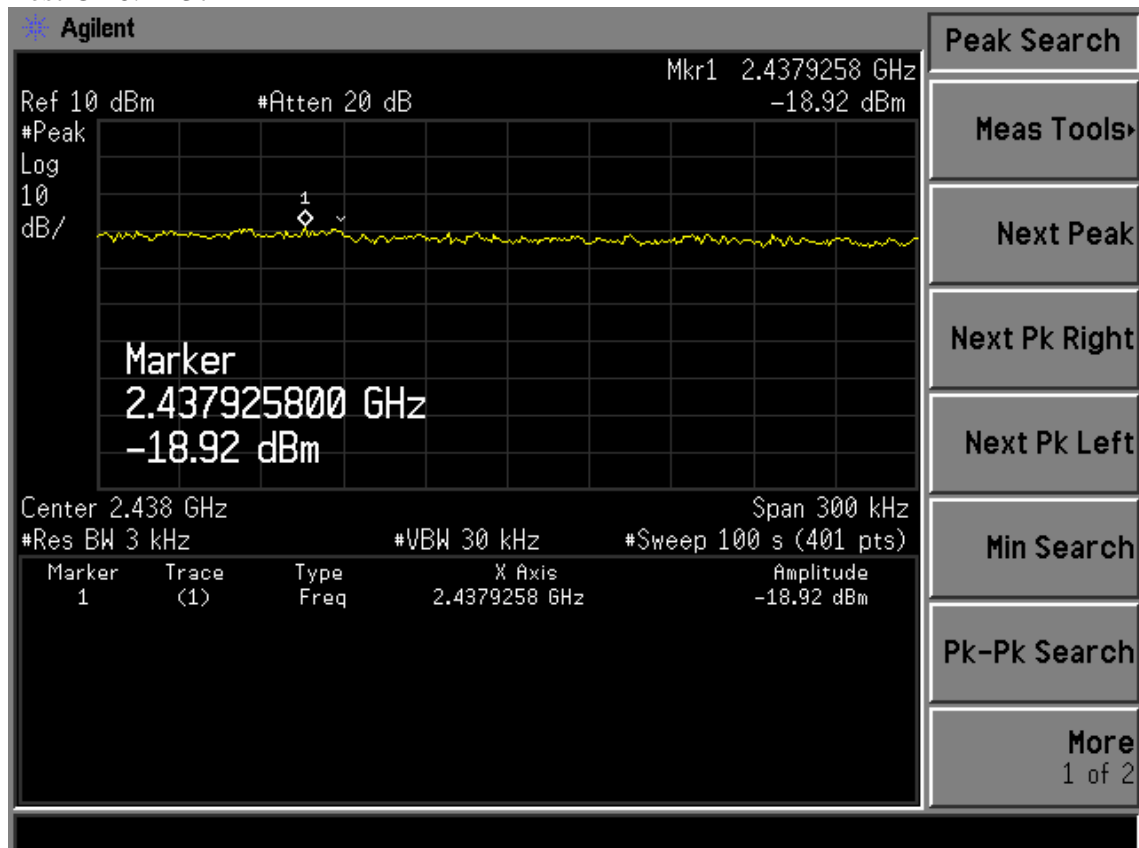

Test CH1: 2462MHz

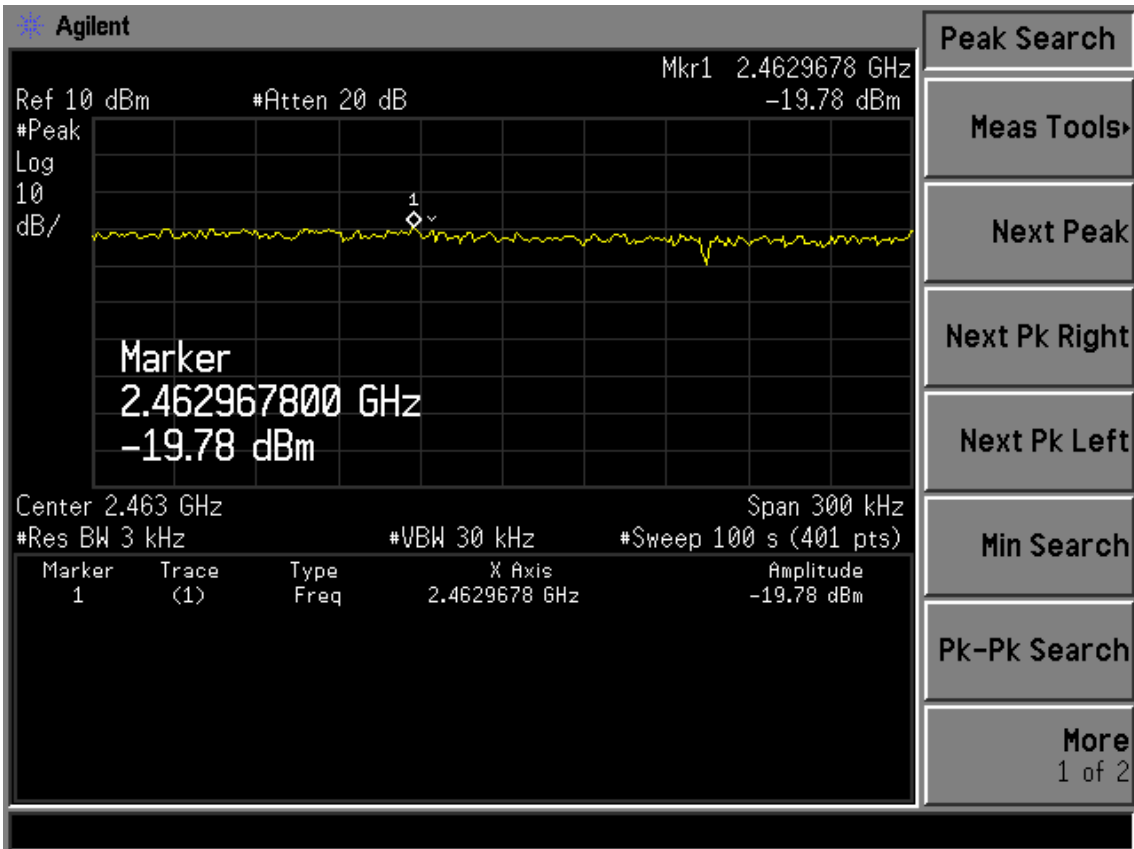

Test Mode: IEEE 802.11g TX

Test CH1: 2412MHz

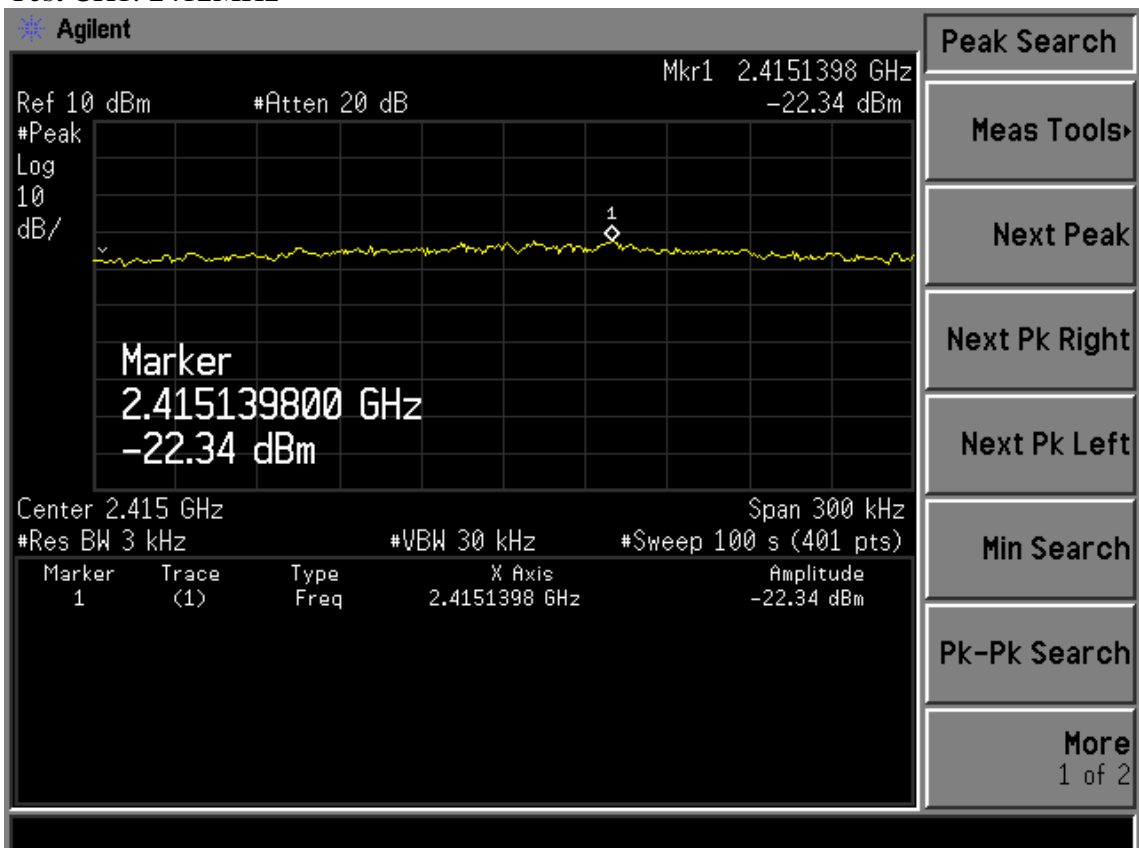

Test CH6: 2437MHz

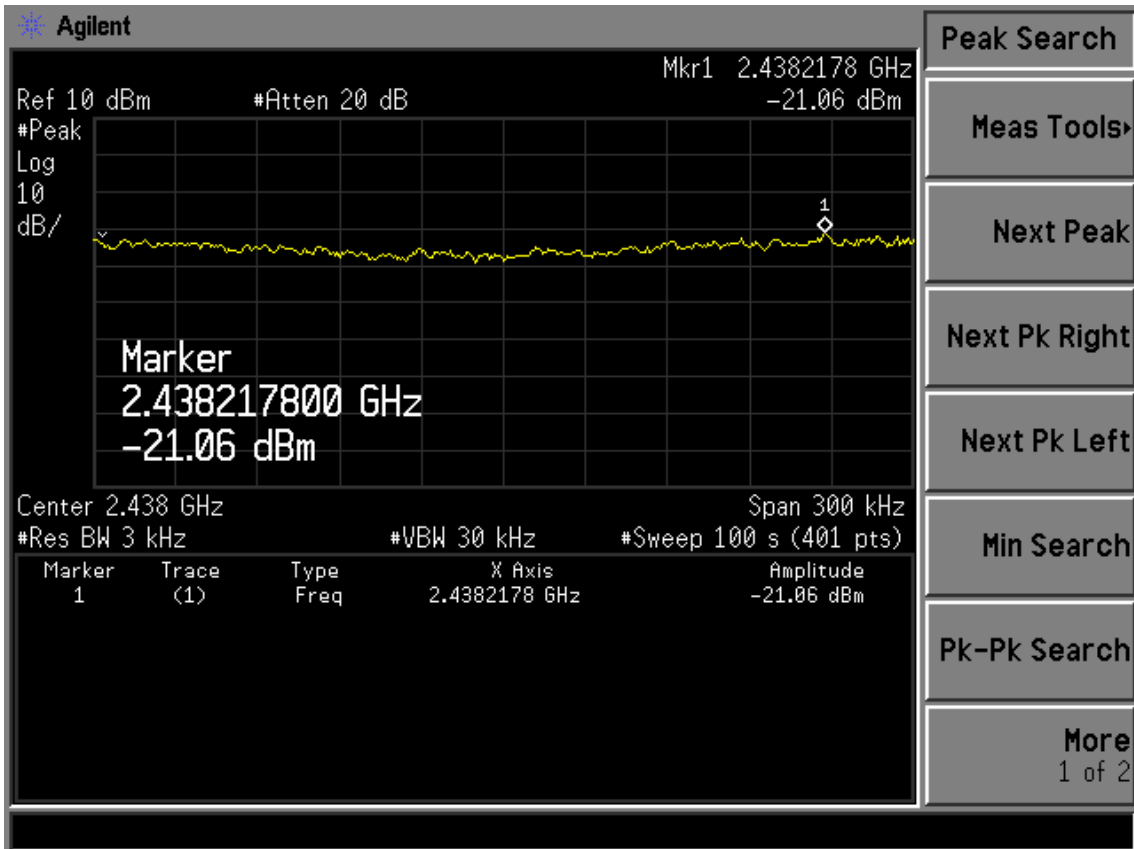

Test CH11: 2462MHz

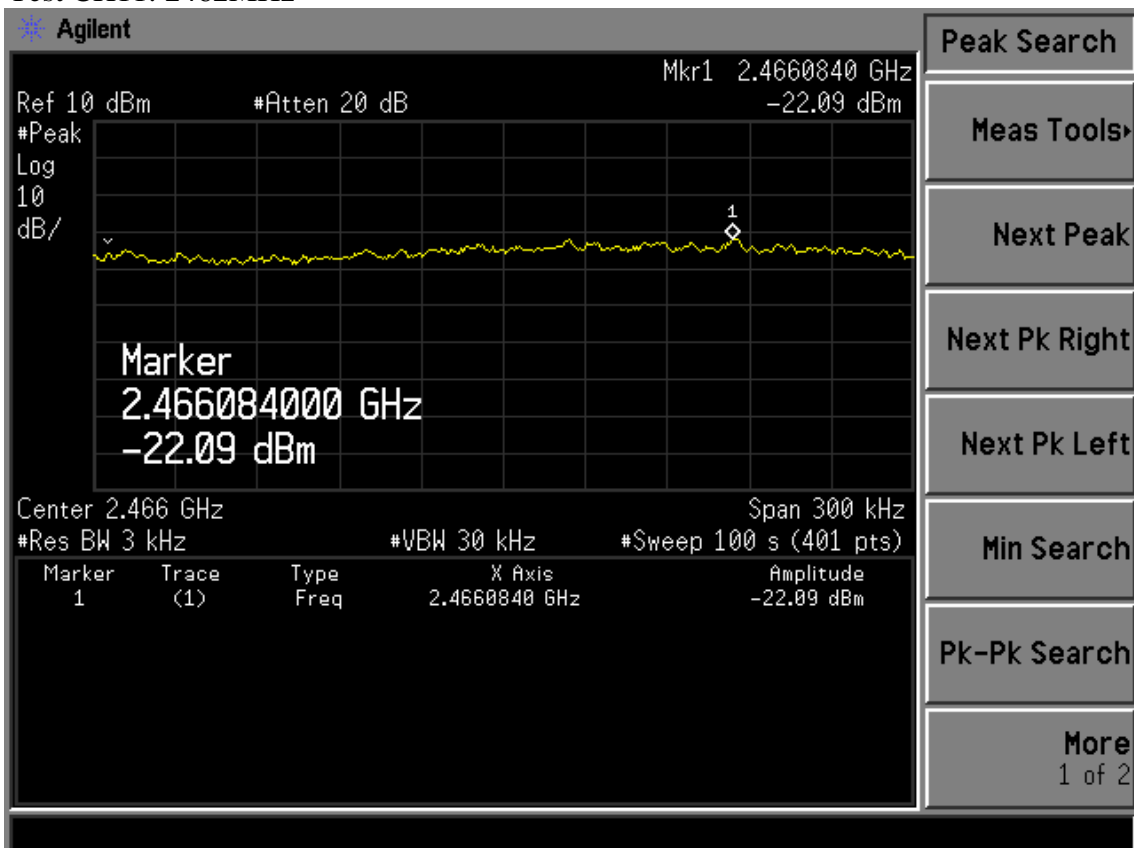

10. ANTENNA REQUIREMENT

10.1 STANDARD APPLICABLE

For intentional device, according to FCC 47 CFR Section 15.203, an intentional radiator shall be designed to ensure that no antenna other than that furnished by the responsible party shall be used with the device. And according to FCC 47 CFR Section 15.247 (b), if transmitting antennas of directional gain greater than 6dBi are used, the power shall be reduced by the amount in dB that the directional gain of the antenna exceeds 6dBi.

10.2 ANTENNA CONNECTED CONSTRUCTION

The antennas used for this product are integral PCB Antenna (Only used for receive) and a dipole antenna with SMA-B connector and that no antenna other than that furnished by the responsible party shall be used with the device, the maximum peak gain of the transmit antenna is only 5dBi.

11.MPE ESTIMATION

11.1.Limit for General Population/ Uncontrolled Exposures

Frequency	Power density (mW/ cm ²)	Averaging time(minutes)
300MHz----1.5GHz	F/1500	30
1.5GHz---100GHz	1.0	30

Frequency(MHz)	Power density (mW/ cm ²)	Averaging time(minutes)
2412	1	30
2437	1	30
2462	1	30

Note: F= Frequency in MHz

11.2.Estimation Result

Mode	CH	Frequency (MHz)	PK Output power (dBm)	Output power (mW)	Antenna Gain (dBi)	antenna Gain (linear)	MPE
11b	1	2412	17.02	50.35	5	3.16	0.0317
	6	2437	17.35	54.33	5	3.16	0.0342
	11	2462	17.26	53.21	5	3.16	0.0335
11b	1	2412	21.86	153.46	5	3.16	0.0966
	6	2437	22.56	180.30	5	3.16	0.1135
	11	2462	21.84	152.76	5	3.16	0.0962

12.DEVIATION TO TEST SPECIFICATIONS

[NONE]