

# **MONSTER BLASTER™**

Manual and Warranty · Manuel et Garantie · Handbuch und Garantieschein  
Manual y Garantía · 说明书和保修单 · 說明書和保修單

Model / Modèle: 2MNSK0928

## Table of Contents

Product Overview	P3-4
Charging the Speaker	P5
Pairing with Bluetooth-enabled Device by NFC	P6
Pairing with Bluetooth-enabled Device by setting	P7
Playing Music with a 3.5mm Audio Line-in Cable (Not Included)	P8
Using with Microphone (Not Included)	P9
Volume / Indoor/Outdoor	P10
Charging Your Device via USB	P11
Precautions	P12-13
Warranty	P14

\* Please fully charge before use.

\* Please key in "0000" if passcode is required when pairing.

\* The speaker will automatically turn off after 15 minutes when there are no connections.

\* For optimum performance with your iOS device, please ensure that your device is running iOS 4.1 or above.

## Product Overview

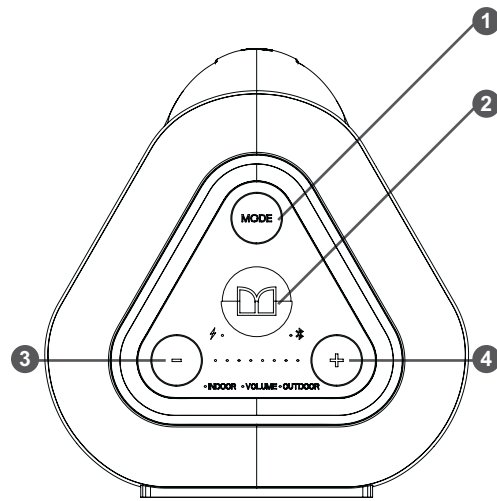

- 1 Mode button
- 2 Power on / off / Bluetooth pairing
- 3 Volume / Indoor / Outdoor level down button
- 4 Volume / Indoor / Outdoor up button

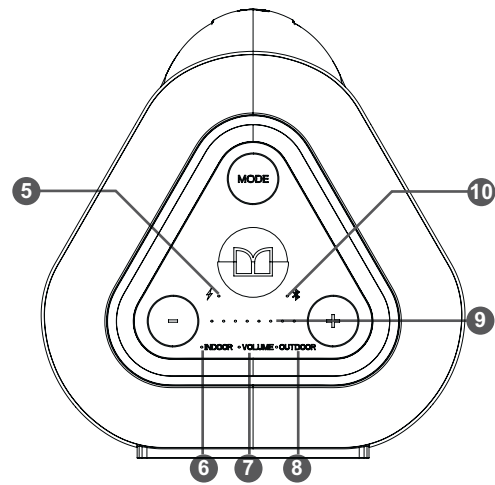

- 5 Power LED indicator
- 6 Indoor mode LED indicator
- 7 Volume mode LED indicator
- 8 Outdoor mode LED indicator
- 9 Volume / Indoor / Outdoor level LED indicators
- 10 Bluetooth LED indicator

ENGLISH

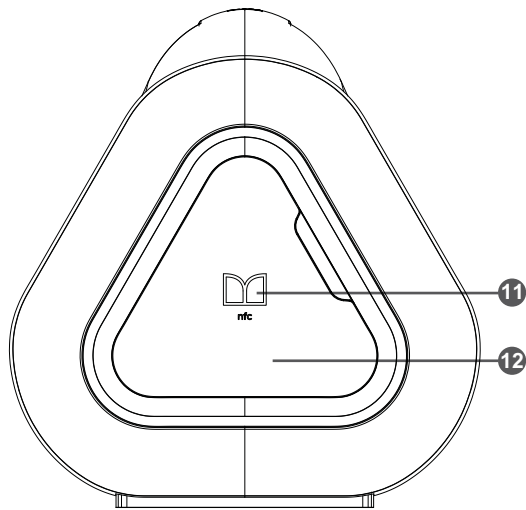

- 11 NFC sensor
- 12 Rubber cover

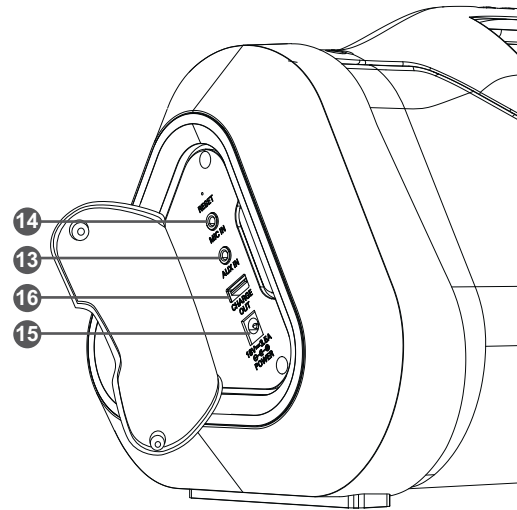

- 13 3.5mm audio line-in for music source
- 14 3.5mm audio line-in for microphone
- 15 Charging port
- 16 Charging out port

## Charging the Speaker

- \* Please fully charge your speaker before use.
- \* To view battery level, turn on the speaker for battery level LED activation.

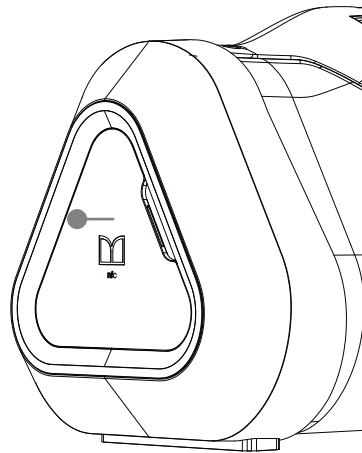

Lift the rubber cover.

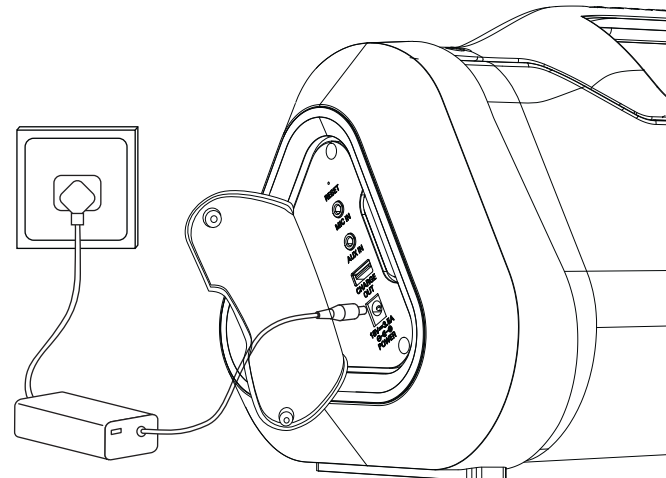

Connect the speaker to power source with the included adapter.

ENGLISH

## Pairing with Bluetooth-enabled Device - By NFC

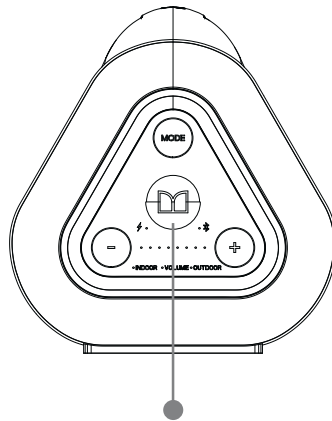

Turn on the speaker by pressing and holding the “” button until a prompt tone occurs.

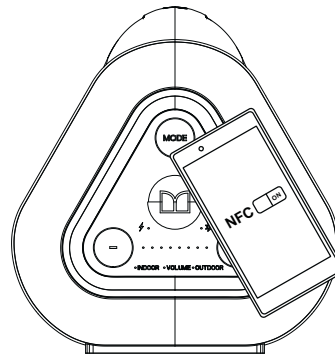

Turn on the NFC feature on your device. Tap your device on the NFC sensor.

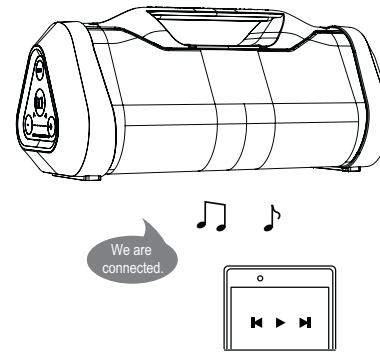

You will hear the voice prompt “We are connected” once successfully paired. You can start playing music.

## Pairing with Bluetooth-enabled Device - By Setting

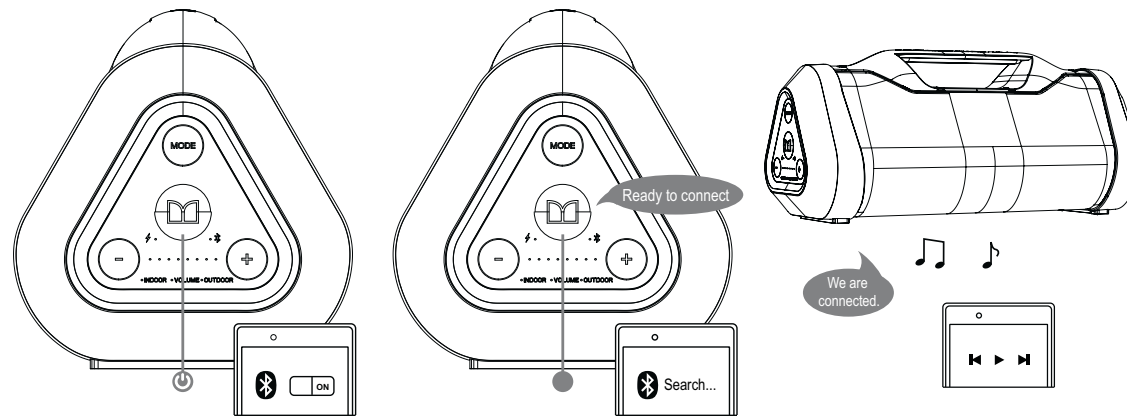

Turn on the speaker by pressing and holding the " " button until a prompt tone occurs. Turn on the Bluetooth feature on your device.

Press and hold " " button until you hear the voice prompt. "Ready to connect". Search and select "Monster Blaster" on your device.

You will hear the voice prompt "We are connected" once successfully paired. You can start playing music.

ENGLISH

### Playing Music with a 3.5mm Audio Line-in Cable (Not Included)

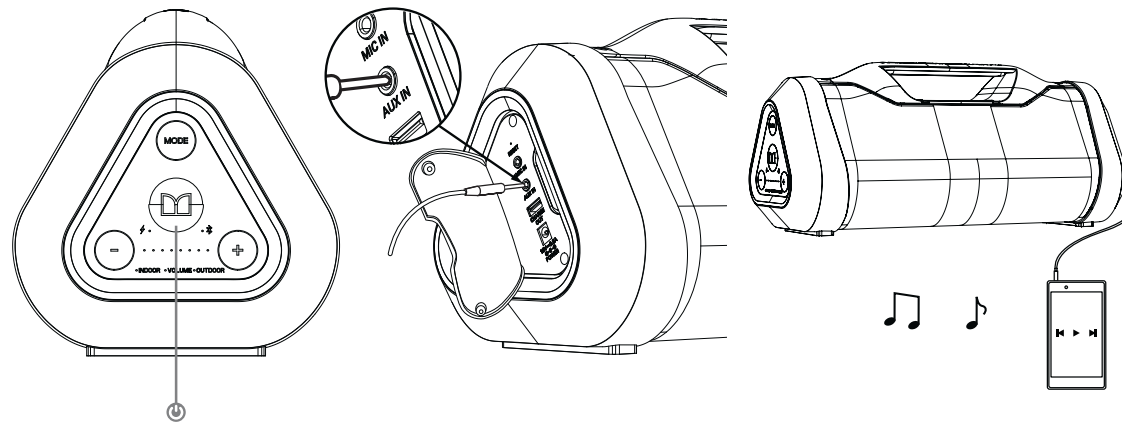

Turn on the speaker by pressing and holding the “” button until a prompt tone occurs.

Connect your device and the speaker with a 3.5mm audio line-in cable.

Start playing music from your device.



## Using a Microphone

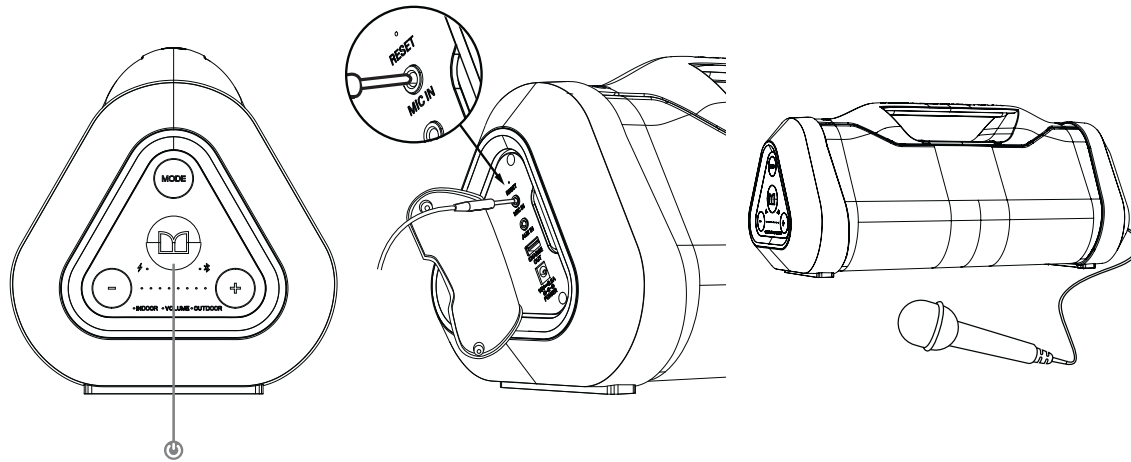

Turn on the speaker by pressing and holding the “” button until a prompt tone occurs.

Connect the speaker and the microphone with the microphone's 3.5mm jack.

Start using microphone while playing music.

## Volume / Indoor / Outdoor

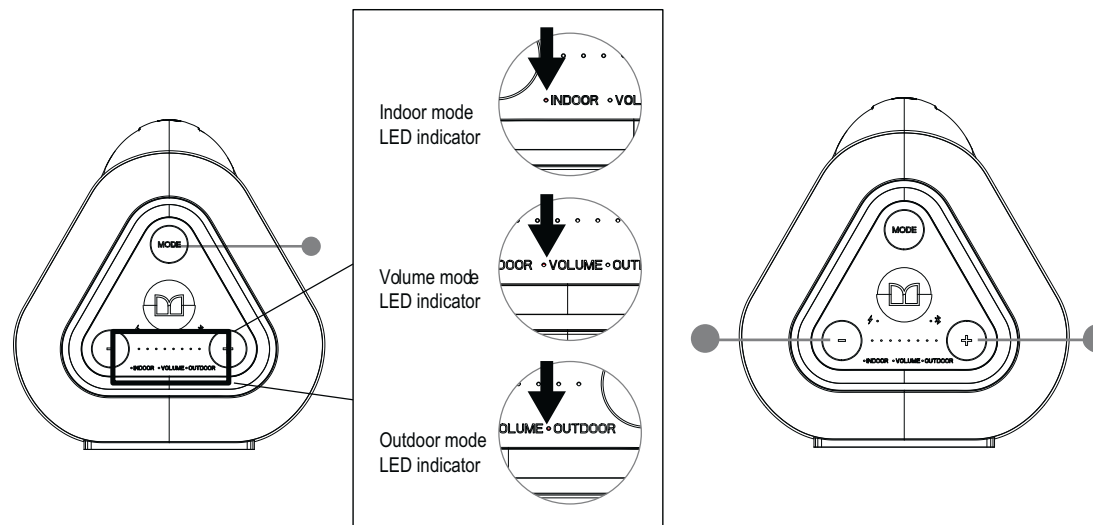

Press the "MODE" button until the corresponding LED indicator illuminates.

Press the "+" to increase the Volume.  
Press the "-" to decrease the Volume.

## Charging Your Device via USB

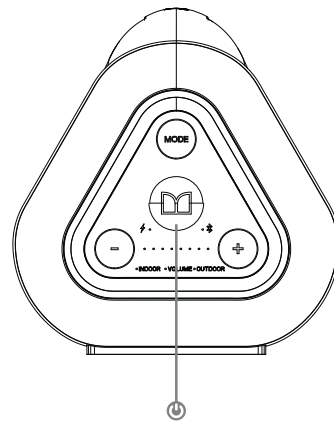

Press and hold the “” button until a prompt tone occurs to turn on the speaker.

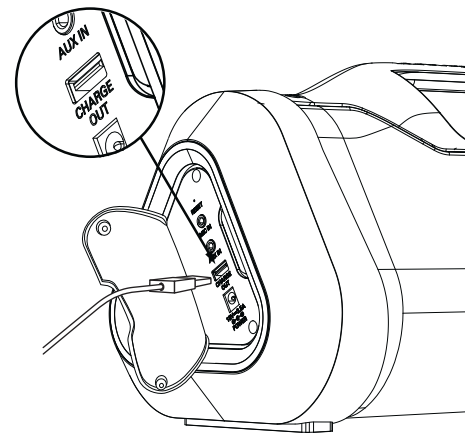

Connect your device and the speaker with a USB cable to start charging.

## Precautions

\* Please read these safety instructions carefully.

- Do not use this product where contact with moisture, liquids, humidity or rain is possible to avoid electric shock.
- Avoid exposing this product to direct sunlight, stove tops or any other heat sources.
- Do not cover the ventilation openings to prevent overheating.
- Do not drop, disassemble, deform, modify or insert any objects into this product.
- Do not attempt to repair, modify or disassemble the product yourself. This product does not contain any user-serviceable components.
- Do not clean the product with alcohol, ammonia based cleaners, abrasive cleaners or wet cloth. Only clean with a soft dry cloth.
- Do not place this product on its side, on slanted surfaces, or on the edge of high surfaces, like shelves, to prevent accidental falling.
- Do not bring your product in to contact with any sharp objects.
- Do not attempt to replace the product battery, it is built-in and is not user changeable.
- Observe all signs and displays that require an electrical device or RF radio product to be switched off in designated areas.
- Turn off your product prior to boarding an aircraft. Do not use the product inside an aircraft unless permitted by your airline.
- Dispose of the product and the product's battery in accordance with local laws and regulations.
- Do not dispose of the battery with regular household waste.

### FCC Statement

This equipment has been tested and found to comply with the limits for a Class B digital device, pursuant to Part 15 of the FCC Rules. These limits are designed to provide reasonable protection against harmful interference in a residential installation. This equipment generates use and can radiate radio frequency energy and, if not installed and used in accordance with the instructions, may cause harmful interference to radio communications. However, there is no guarantee that interference will not occur in a particular installation. If this equipment does cause harmful interference to radio or television reception, which can be determined by turning the equipment off and on, the user is encouraged to try to correct the interference by one of the following measures:

- Reorient or relocate the receiving antenna.
- Increase the separation between the equipment and receiver.
- Connect the equipment into an outlet on a circuit different from that to which the receiver is connected.
- Consult the dealer or an experienced radio / TV technician for help.

### FCC Notice

This device complies with Part 15 of the FCC Rules.

Operation is subject to the following two conditions:

- 1 This device may not cause harmful interference, and
- 2 This device must accept any interference received, including interference that may cause undesired operation.

FCC Caution

- Any changes or modifications not expressly approved by the party responsible for compliance could void the user's authority to operate this equipment.
- This device and its antenna(s) must not be co-located or operating in conjunction with any other antenna or transmitter.

Industry Canada (IC) Compliance Notice

This device complies with Industry Canada licence-exempt RSS standard(s). Operation is subject to the following two conditions: (1) this device may not cause interference, and (2) this device must accept any interference, including interference that may cause undesired operation of the device. Under Industry Canada regulations, this radio transmitter may only operate using an antenna of a type and maximum (or lesser) gain approved for the transmitter by Industry Canada. To reduce potential radio interference to other users, the antenna type and its gain should be so chosen that the equivalent isotropically radiated power (e.i.r.p.) is not more than that necessary for successful communication.

FCC ID: WWE-2MNSK0928

To locate the FCC and IC identification numbers, please look on the underside of the Team Event.

Model number 2MNSK0928

ENGLISH

**LIMITED LIFETIME WARRANTY FOR CONSUMERS****What is covered under the Lifetime Warranty?**

Monster® warrants that this product will be free from defects in workmanship and materials under normal use ("Lifetime Warranty"). In a case where the product is determined to be "defective", we will repair the product free of charge. If we cannot repair the product, we will replace it for you free of charge.

**How long am I covered?**

You are covered for the Lifetime of the product which means that as long as we are still manufacturing and selling the product we cover you under warranty.

**What is not covered under the Lifetime Warranty?**

1. Normal wear and tear of product use.
2. Misuse, lack of care, mishandling, accidental damage, abuse or other abnormal use.
3. Use of the product other than for its intended purpose.
4. Damage caused by improper or unauthorized repair or maintenance.
5. Product that has been modified or altered.
6. Any product that is not manufactured by Monster® (including, without limitation, any non-Monster® product that is used in connection with the product).

**Customer Service Phone Number:**

1-877-543-3540

ENGLISH

## Tabla de Contenidos

Resumen del Producto	P17-18
Carga del Altavoz	P19
Mediante NFC - Emparejamiento con Dispositivos con Función de Bluetooth	P20
Mediante Ajuste - Emparejamiento con Dispositivos con Función de Bluetooth	P21
Reproducción de Música con un Cable de Audio de 3,5mm (No incluido)	P22
Uso con Micrófono	P23
Control de Volumen / Interior / Al aire libre	P24
Cómo cargar su dispositivo con un cable USB	P25
Precauciones	P26-27

\* Por favor, cargue completamente antes del uso.

\* Introduzca "0000" en caso de que se pida un código de acceso para el emparejamiento.

\* El altavoz se apagará automáticamente después de 15 minutos de no detectar ninguna conexión.

\* Para un rendimiento óptimo con dispositivos iOS, por favor, asegúrese de que su dispositivo funciona con la versión iOS 4.1 o una posterior.



## Resumen del Producto

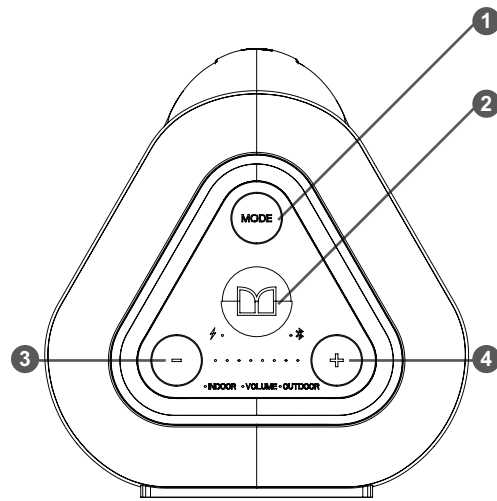

- 1 Botón Mode
- 2 Encendido / Apagado / Emparejamiento Bluetooth
- 3 Botón de disminución del Volumen / Interior / Exterior
- 4 Botón de Aumento de Volumen / Interior / Exterior

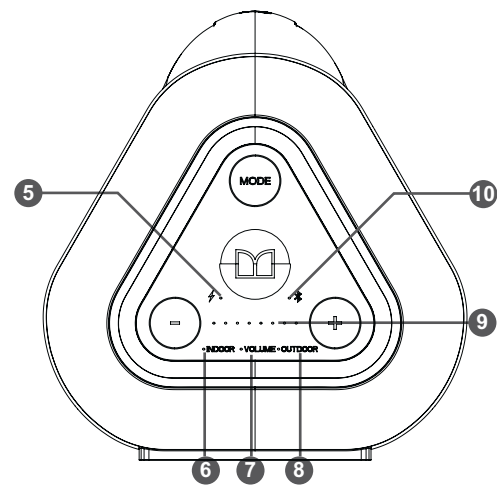

- 5 Indicador LED de Encendido
- 6 Indicador LED del Modo de Interior
- 7 Indicador LED del Modo de Volumen
- 8 Indicador LED del Modo de Exterior
- 9 Indicadores LED del Nivel de Volumen / Interior / Exterior
- 10 Bluetooth LED

ESPAÑOL

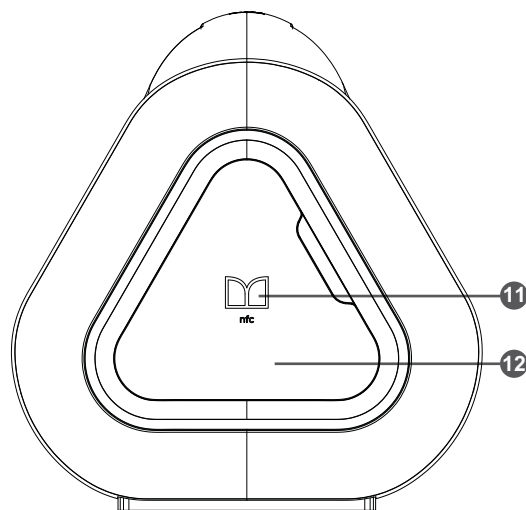

- 11 Capteur NFC
- 12 Protection en caoutchouc

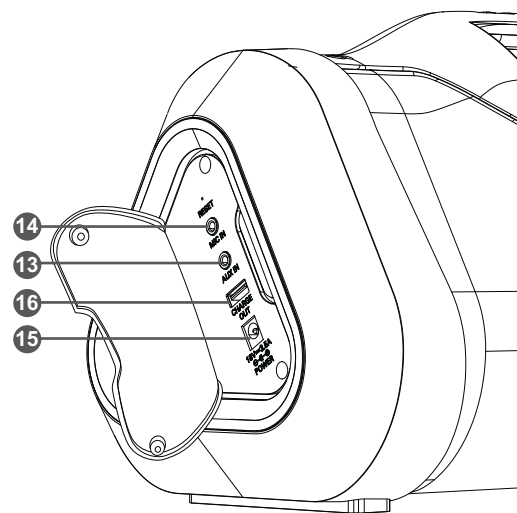

- 13 Entrada de Audio de 3,5mm para la Fuente de Música
- 14 Entrada de Audio de 3,5mm para Micrófono
- 15 Puerto de Carga
- 16 Puerto de Salida de Carga

## Carga del Altavoz

\* Por favor, cargue por completo su altavoz antes del uso.

\* Para consultar el nivel de batería, encienda el altavoz para que se active el indicador LED del nivel de batería.z

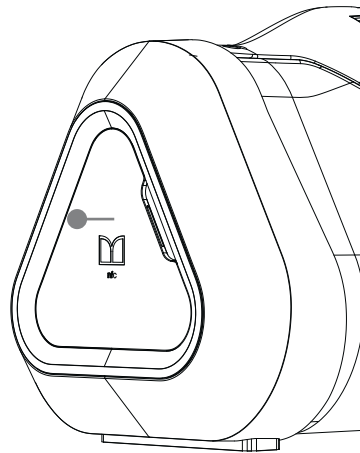

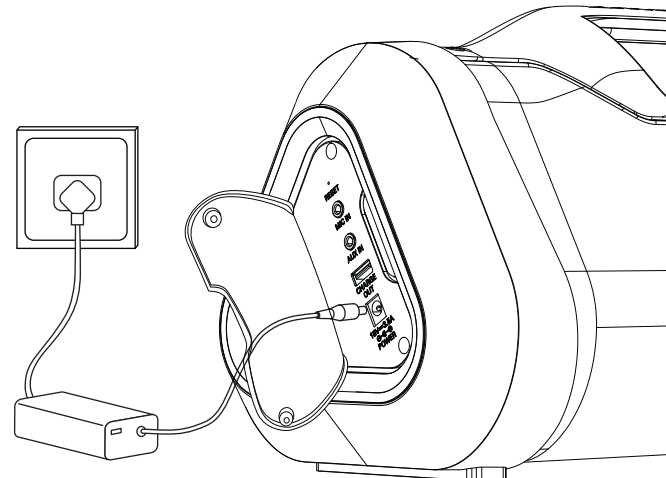

Levante la cubierta de goma.

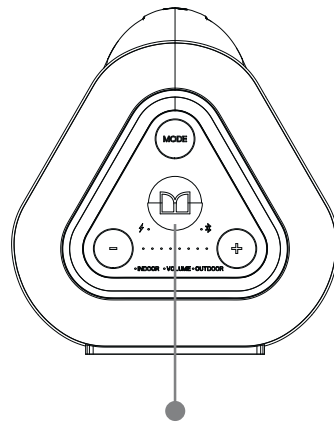

Conecte el altavoz a una fuente de alimentación con el adaptador que se incluye.

## Emparejamiento con Dispositivos con Función de Bluetooth - Mediante NFC



Encienda el altavoz al presionar y dejando presionado el botón “” hasta que se escuche el tono de encendido.

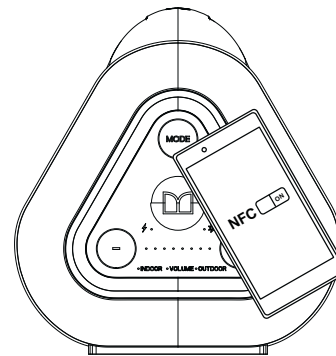

Encienda la función NFC de su dispositivo. Toque su dispositivo por la parte del sensor NFC.

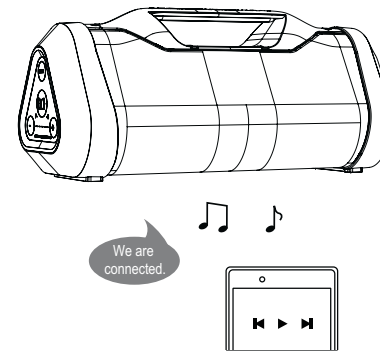

Oirá el aviso de voz “We are connected” una vez se haya conseguido el emparejamiento. Ahora ya podrá comenzar la reproducción de música.

## Uso con Micrófono

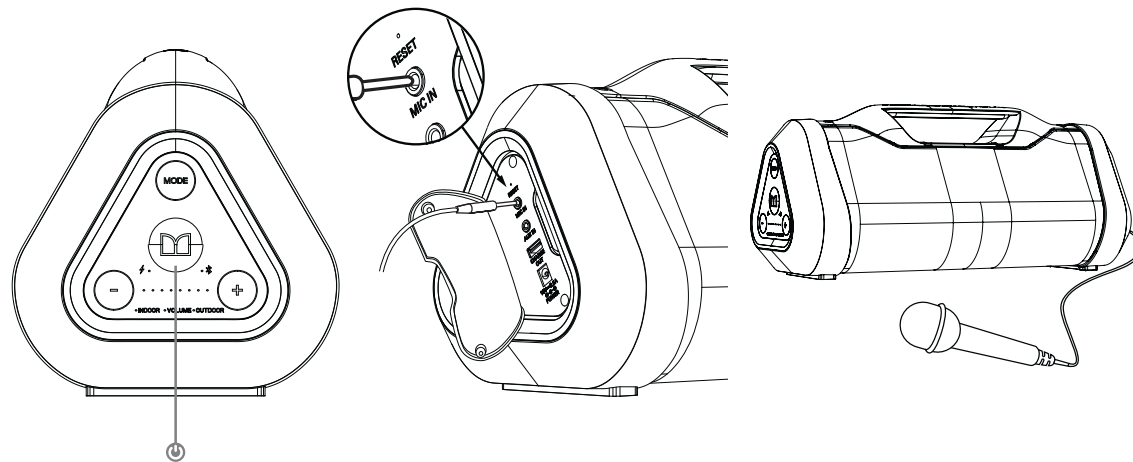

Mantenga pulsado el botón " ■■ " hasta que oiga un tono de aviso para encender el altavoz.

Conecte el altavoz y el micrófono con el conector de 3.5mm del micrófono.

Comience a usar el micrófono mientras reproduce música.

## Control de Volumen / Interior / Al aire libre EQ

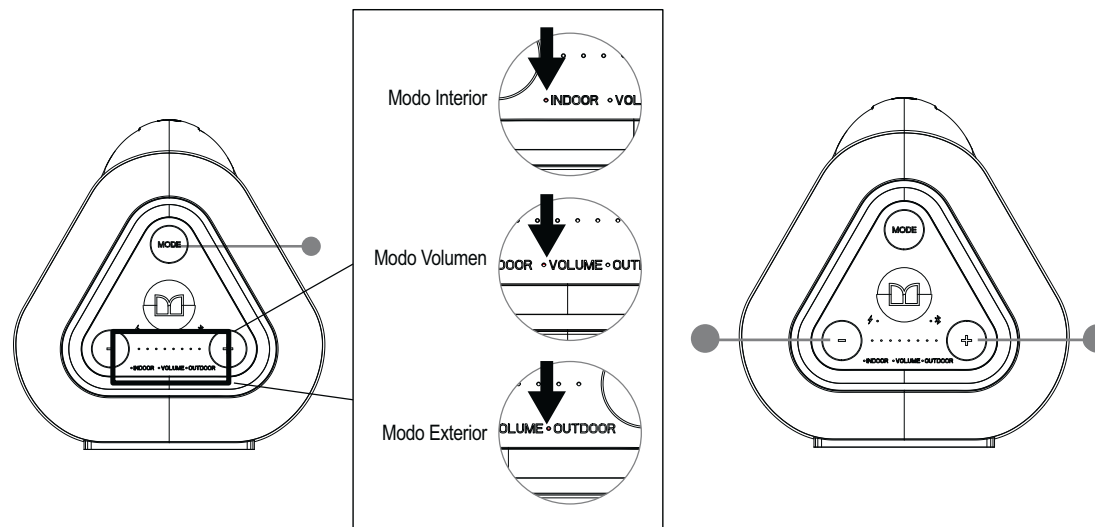

ESPAÑOL

Pulse el botón "MODE" hasta que se ilumine el indicador LED correspondiente.

Pulse "+" para subir el nivel de Volumen  
Pulse "-" para bajar el nivel de Volumen

## USB로 기기 충전

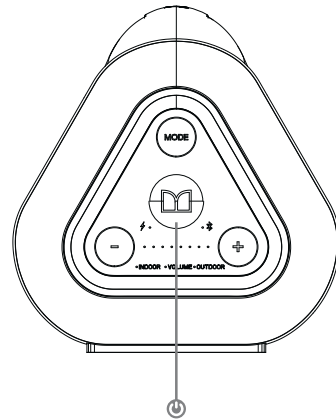

스피커가 켜질 때까지 “ ” 버튼을 눌러주십시오.

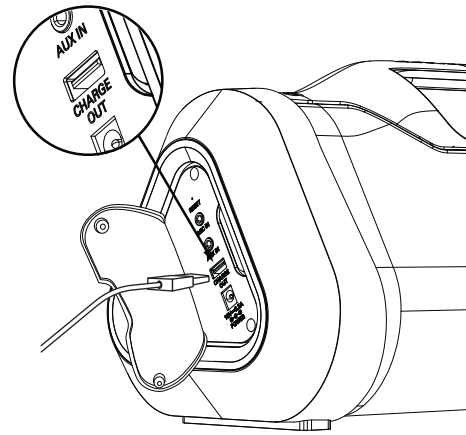

기기와 스피커와 USB 케이블을 연결해서 충전하기 시작하십시오.

연결

## 예 방 책

\* 안전 지침을 주의 깊게 읽으십시오.

- 감전을 방지하기 위해 수분, 액체, 습기를 접촉하거나 비가 내릴 수 있는 곳에서 이 제품을 사용하지 마십시오.
- 작동 고장을 방지하기 위해 직사광선이나 난로나 다른 열원에 이 제품을 노출하지 마십시오.
- 과열을 방지하기 위해 환기구를 덮지 마십시오.
- 이 제품을 떨어뜨리거나 분해하거나 변형하거나 수정하거나 이 제품에 어느 물체도 넣지 마십시오.
- 직접 자신이 제품을 수리하거나 변형하거나 분해하려 마십시오. 이 제품에는 사용자가 서비스를 받을 수 있는 부품이 들어 있지 않습니다.
- 제품을 알코올이나 암모니아 바탕의 세척제나 청소용 연마제나 컷은 수건으로 닦지 마시고, 오직 부드러운 마른 천으로만 닦아 주십시오.
- 돌발적으로 떨어질 수 있으니 이 제품을 측면이나 경사면이나 선반과 같은 높은 곳의 가장자리에 놓지 마십시오.
- 이 제품이 날카로운 물체와 접촉하면 긁히고 작동 고장이 날 수 있으므로 이 제품을 날카로운 물체와 접촉하지 마십시오.
- 제품 배터리를 대체하려 하지 마십시오. 이 배터리는 내장되어 있으며 사용자가 충전할 수 있는 것이 아닙니다.
- 전자 기기나 RF 라디오 제품을 정해진 구역에서 스위치를 끄기 위해 모든 기호와 표시판을 살펴보십시오.
- 비행기에 승선하기 전에 제품 전원을 끄십시오. 항공사가 허가하지 않는 한 기내에서 제품을 사용하지 마십시오.
- 지역 법과 규정에 따라서 제품과 제품의 배터리를 폐기하십시오.
- 일반 가정 쓰레기와 함께 배터리를 폐기하지 마십시오.

### FCC 설명

이 장비의 시험 결과 FCC 규정 제15조에 따른 B등급 디지털 장치에 대한 제한을 준수하는 것으로 확인되었습니다. 이 제한은 거주 시설 설치의 유해 방해에 대한

합리적인 보호를 제공하기 위해 설정되었습니다. 이 장비를 지침에 따라서 설치하지 않고 사용하지 않으면

무선 통신 유해 방해를 초래할 수 있고, 무선 주파수 에너지를 방출할 수 있습니다. 하지만 특정 장치에서 유해 방해가 일어나지 않는다고

보장할 수는 없습니다. 이 장비가 라디오나 텔레비전 수신에 유해 방해를 초래하는 것은

장비를 끄고 켜는 것을 통해서 알 수 있는데, 유해 방해를 초래하는 경우에는 다음 중 한 가지 방법을 이용해서 유해 방해를 조정해볼 수 있습니다.

- 수신 안테나의 방향을 바꾸거나 위치를 변경합니다.
- 장비와 수신기 사이의 거리를 늘립니다.
- 수신기가 연결되지 않은 다른 회로의 콘센트에 장비를 연결합니다.
- 대리점 또는 숙련된 라디오/TV 기술자에게 도움을 요청합니다.

### FCC 주의 사항

이 기기는 FCC 규정 제 15조를 준수합니다.

작동에는 다음 두 가지 조건이 적용됩니다.

1 이 기기는 유해 방해를 초래하지 않을 수 있으며,

2 이 기기는 반갑잡은 작동을 초래할 수 있는 유해 방해를 비롯한 어떤 유해도 반드시 수락해야 합니다.



FCC 경고

- 규정 준수에 책임 있는 당사자가 수락하지 않는 변경이나 변형이 있다면 이 장비를 가동하는 사용자의 권한을 무효로 할 수 있습니다.
- 이 기기와 안테나는 같은 공간에 둘 수 없으며 다른 안테나나 송신기와 함께 결합해서 작동할 수 없습니다.

IC 규정 사항

이 기기는 IC (Industry Canada) licence-exempt RSS 기준을 준수합니다. 작동에는 다음 두 가지 조건이 적용됩니다. (1) 이 기기는 유해 방해를 초래하지 않을 수 있으며, (2) 이 기기는 반감잡은 작동을 초래할 수 있는 유해 방해를 비롯한 어떤 유해 방해도 반드시 수락해야 합니다. IC 규정에 따라 이 무선 송신기는 IC가 송신기 승인을 받은 유형과 최대(또는 최저) 개인의 안테나를 사용해서만 작동할 수 있습니다. 다른 사용자의 잠재적인 전파 장애를 줄이기 위해 안테나 유형과 개인은 등가 등방성 복사 전력 가 성공적인 통신을 하는 데 필요 이상을 선택해서는 안됩니다.

FCC ID: 2MNSK0928

FCC 및 IC 식별 번호는 Monster Blaster™의 밑면에 있습니다.

모델 번호 2MNSK0928



Customer Service: 877-543-3540  
Model#: 2MNSK0928

The M Monster logo, and Powered by Monster are trademarks or registered trademarks used under license of Monster, Inc.  
©2021 All rights reserved. Manufactured, marketed and distributed by Lifeworks Technology Group LLC, under license.

## FCC WARNING

This device complies with part 15 of the FCC Rules. Operation is subject to the following two conditions: (1) this device may not cause harmful interference, and (2) this device must accept any interference received, including interference that may cause undesired operation.

Any changes or modifications not expressly approved by the party responsible for compliance could void the user's authority to operate the equipment.

NOTE: This equipment has been tested and found to comply with the limits for a Class B digital device, pursuant to Part 15 of the FCC Rules. These limits are designed to provide reasonable protection against harmful interference in a residential installation. This equipment generates, uses and can radiate radio frequency energy and, if not installed and used in accordance with the instructions, may cause harmful interference to radio communications.

However, there is no guarantee that interference will not occur in a particular installation.

If this equipment does cause harmful interference to radio or television reception, which can be determined by turning the equipment off and on, the user is encouraged to try to correct the interference by one or more of the following measures:

- Reorient or relocate the receiving antenna.
- Increase the separation between the equipment and receiver.
- Connect the equipment into an outlet on a circuit different from that to which the receiver is connected.
- Consult the dealer or an experienced radio/TV technician for help.

To maintain compliance with FCC's RF Exposure guidelines, This equipment should be installed and operated with minimum distance between 20cm the radiator your body: Use only the supplied antenna.