

## RF MEASUREMENT REPORT

---

**FCC ID:** WVTWOUXUN30

**Applicant:** Quanzhou Wouxun Electronics Co., Ltd.

**Product:** Two-way Radio (business radio)

**Model No.:** KG-S84B

**Serial Model No.** KG-S85B, KG-S84BX, KG-S84B Plus, KG-S84B Limited Edition, KG-S86B, KG-S87B, KG-S86BX, KG-S86B Plus, KG-S86B Limited Edition

**Brand Name:** WOUXUN

**FCC Classification:** TNF - Licensed Non-Broadcast Transmitter Held to Face

**FCC Rule Part(s):** FCC Part 90 Subpart B, FCC Part 2

**Test Date:** December 25, 2021 ~ March 01, 2022

**Reviewed By:**

\_\_\_\_\_  
Jame Yuan

**Approved By:**

\_\_\_\_\_  
Robin Wu



The test results relate only to the samples tested.

This equipment has been shown to be capable of compliance with the applicable technical standards as indicated in the measurement report and was tested in accordance with the measurement procedures specified in ANSI C63.10-2013. Test results reported herein relate only to the item(s) tested.

The test report shall not be reproduced except in full without the written approval of MRT Technology (Suzhou) Co., Ltd.

**Revision History**

Report No.	Version	Description	Issue Date	Note
2111RSU076-U2	Rev. 01	Initial Report	03-04-2022	Valid

---

## CONTENTS

Description	Page
<b>1. General Information .....</b>	<b>5</b>
1.1. Applicant .....	5
1.2. Manufacturer .....	5
1.3. Testing Facility .....	5
1.4. Product Information.....	6
1.5. Working Frequencies .....	7
<b>2. Test Configuration .....</b>	<b>8</b>
2.1. Test Mode.....	8
2.2. Test System Connection Diagram.....	8
2.3. Applied Standards.....	8
2.4. Test Environment Condition .....	8
<b>3. Measuring Instrument .....</b>	<b>9</b>
<b>4. Measurement Uncertainty.....</b>	<b>10</b>
<b>5. Test Result.....</b>	<b>11</b>
5.1. Summary .....	11
5.2. RF Power Output Measurement .....	12
5.2.1. Test Limit .....	12
5.2.2. Test Procedure .....	12
5.2.3. Test Setting .....	12
5.2.4. Test Setup .....	12
5.2.5. Test Result .....	12
5.3. Frequency Stability Measurement .....	13
5.3.1. Test Limit .....	13
5.3.2. Test Procedure .....	13
5.3.3. Test Setting .....	13
5.3.4. Test Setup .....	13
5.3.5. Test Result .....	14
5.4. Modulation Characteristics Measurement .....	15
5.4.1. Test Limit .....	15
5.4.2. Test Procedure .....	15
5.4.3. Test Setting .....	15
5.4.4. Test Setup .....	16
5.4.5. Test Result .....	16
5.5. Occupied Bandwidth Measurement.....	17
5.5.1. Test Limit.....	17

---

5.5.2.	Test Procedure .....	17
5.5.3.	Test Setting .....	17
5.5.4.	Test Setup .....	17
5.5.5.	Test Result .....	17
5.6.	Transient Frequency Behavior Measurement.....	18
5.6.1.	Test Limit .....	18
5.6.2.	Test Procedure .....	18
5.6.3.	Test Setting .....	19
5.6.4.	Test Setup .....	20
5.6.5.	Test Result .....	20
5.7.	Emission Mask Measurement.....	21
5.7.1.	Test Limit .....	21
5.7.2.	Test Procedure .....	21
5.7.3.	Test Setting .....	21
5.7.4.	Test Setup .....	22
5.7.5.	Test Result .....	22
5.8.	Radiated Spurious Emission Measurement.....	23
5.8.1.	Test Limit .....	23
5.8.2.	Test Procedure .....	23
5.8.3.	Test Setting .....	23
5.8.4.	Test Setup .....	23
5.8.5.	Test Result .....	24
<b>Appendix A – Test Result .....</b>		<b>25</b>
A.1	RF Power Output Test Result .....	25
A.2	Frequency Stability Test Result.....	26
A.3	Audio Frequency Response Test Result.....	27
A.4	Modulation Limiting Test Result .....	29
A.5	Occupied Bandwidth Test Result .....	30
A.6	Transient Frequency Behavior Test Result .....	31
A.7	Emission Mask Test Result .....	32
A.8	Conducted Spurious Emission Test Result.....	33
A.9	Spurious Emission Test Result .....	35
<b>Appendix B – Test Setup Photograph .....</b>		<b>36</b>
<b>Appendix C – EUT Photograph .....</b>		<b>37</b>

---



#### 1.4. Product Information

Product Name	Two-way Radio (business radio)
Model No.	KG-S84B
Serial Model No.	KG-S85B, KG-S84BX, KG-S84B Plus, KG-S84B Limited Edition, KG-S86B, KG-S87B, KG-S86BX, KG-S86B Plus, KG-S86B Limited Edition
Brand Name	WOUXUN
Frequency Range	450 ~ 470 MHz
Serial Number	20211122Sample#16 (Conducted) 20211122Sample#20 (Radiated and AC conducted Emission)
EUT Type	Portable Device
Type of Modulation	FM
Antenna Type	SMA-Male
Antenna Gain	2.15 dBi
Accessories	
Adapter	Model No.: DSX-120050L-US Input Power: 100 - 240V ~ 50-60Hz, 0.3A Output Power: 12VDC 0.5A
Rechargeable Li-ion Battery	Model No.: 1A20KG-15 Capacitance: 2000mAh 14.80Wh Rated Voltage: 7.4V
Li-ion Battery Charger	Input Power: 12VDC Output Power: 8.4VDC 450mA
Remark: 1. The information of EUT was provided by the manufacturer, and the accuracy of the information shall be the responsibility of the manufacturer. 2. The difference between the above models is plastic enclosure with different colors and shapes.	

**1.5. Working Frequencies**

Channel	Frequency	Channel	Frequency
01	464.5500MHz	09	464.5000 MHz
02	467.9250 MHz	10	467.7625 MHz
03	461.0375 MHz	11	467.8125 MHz
04	461.0625 MHz	12	467.8500 MHz
05	461.0875 MHz	13	467.8750 MHz
06	461.1125 MHz	14	467.9000 MHz
07	461.1375 MHz	15	461.1875 MHz
08	461.1625 MHz	16	461.2125 MHz

## 2. Test Configuration

### 2.1. Test Mode

Test Mode	Mode 1: Transmit at channel 461.0375MHz
	Mode 2: Transmit at channel 464.5500MHz
	Mode 3: Transmit at channel 467.9250MHz

### 2.2. Test System Connection Diagram

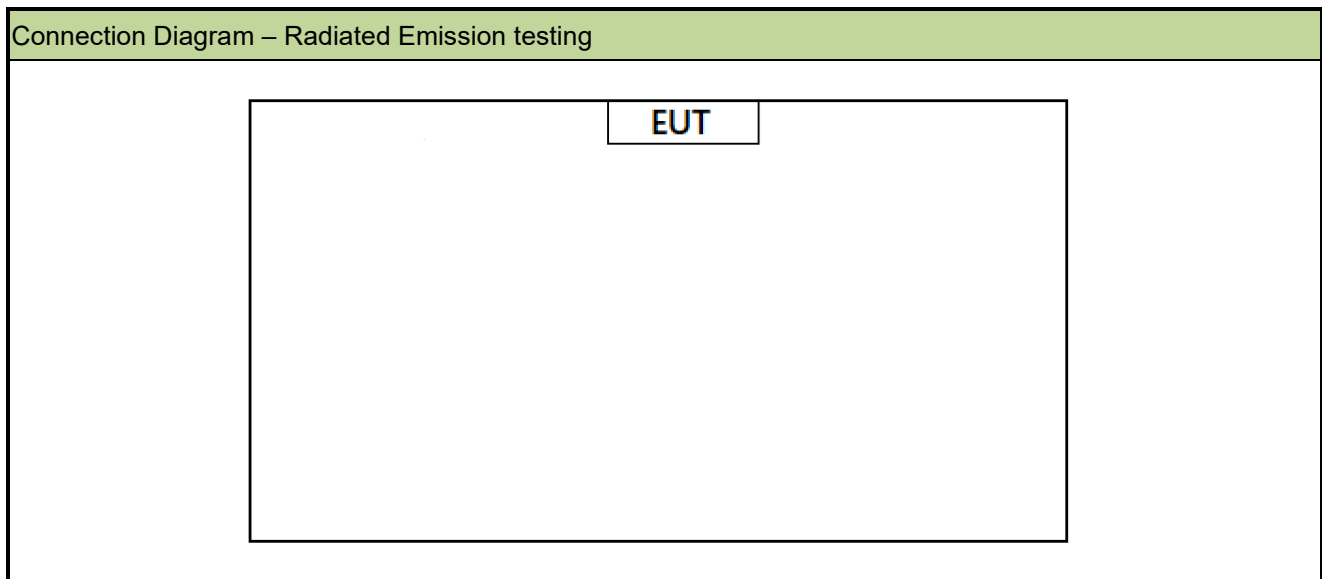

### 2.3. Applied Standards

According to the specifications of the manufacturer, the EUT must comply with the requirements of the following standards:

FCC Part 90 Subpart I and Subpart B

FCC Part 2

ANSI C63.26-2015

### 2.4. Test Environment Condition

Ambient Temperature	15 ~ 35°C
Relative Humidity	20 ~ 75%RH



### 3. Measuring Instrument

Instrument	Manufacturer	Model No.	Asset No.	Cali. Interval	Cali. Due Date	Test Site
EMI Test Receiver	R&S	ESR7	MRTSUE06001	1 year	2022/12/29	WZ-AC1
Horn Antenna	Schwarzbeck	BBHA 9120D	MRTSUE06023	1 year	2022/9/16	WZ-AC1
Preamplifier	Agilent	83017A	MRTSUE06076	1 year	2022/11/12	WZ-AC1
TRILOG Antenna	Schwarzbeck	VULB 9168	MRTSUE06172	1 year	2022/8/5	WZ-AC1
Thermohygrometer	Yuhuaze	HTC-2	MRTSUE06184	1 year	2022/8/10	WZ-AC1
Anechoic Chamber	TDK	WZ-AC1	MRTSUE06212	1 year	2022/4/29	WZ-AC1
Thermohygrometer	testo	608-H1	MRTSUE06403	1 year	2022/6/28	WZ-AC1
Signal Analyzer	Keysight	N9010B	MRTSUE06607	1 year	2022/12/29	WZ-AC1
Temperature Chamber	BAOYT	BYH-150CL	MRTSUE06051	1 year	2022/10/10	WZ-TR3
Thermohygrometer	testo	608-H1	MRTSUE06401	1 year	2022/6/28	WZ-TR3
Signal Analyzer	Agilent	N9020A	MRTSUE06106	1 year	2022/4/13	WZ-SR5
Audio Analyzer	R&S	UPV	MRTSUE06357	1 year	2022/5/18	WZ-SR5
Signal Generator	R&S	SMU200A	MRTSUE06490	1 year	2022/2/23	WZ-SR5
Modulation Analyzer	HP	HP8901A	MRTSUE06098	1 year	2022/9/12	WZ-SR5

Software	Version	Function
EMI Software	V3	EMI Test Software

#### 4. Measurement Uncertainty

Where relevant, the following test uncertainty levels have been estimated for tests performed on the EUT as specified in CISPR 16-4-2. This uncertainty represents an expanded uncertainty expressed at approximately the 95% confidence level using a coverage factor of  $k = 2$ .

Radiated Disturbance
Measurement Uncertainty for a Level of Confidence of 95% ( $U=2Uc(y)$ ): Horizontal: 30MHz~300MHz: 5.04dB 300MHz~1GHz: 4.95dB 1GHz~40GHz: 6.40dB Vertical: 30MHz~300MHz: 5.24dB 300MHz~1GHz: 6.03dB 1GHz~40GHz: 6.40dB
Spurious Emissions, Conducted
Measuring Uncertainty for a Level of Confidence of 95% ( $U=2Uc(y)$ ): 0.78dB
Output Power
Measuring Uncertainty for a Level of Confidence of 95% ( $U=2Uc(y)$ ): 1.13dB
Power Spectrum Density
Measuring Uncertainty for a Level of Confidence of 95% ( $U=2Uc(y)$ ): 1.15dB
Occupied Bandwidth
Measuring Uncertainty for a Level of Confidence of 95% ( $U=2Uc(y)$ ): 0.28%

## 5. Test Result

### 5.1. Summary

FCC Section(s)	Test Description	Test Condition	Verdict
§90.205(r), §2.1046(a)	RF Power Output	Conducted	Pass
§90.213(a), §2.1055	Frequency Stability		Pass
§2.1047	Modulation Characteristics		Pass
§2.1049	Occupied Bandwidth		Pass
§2.1051	Spurious Emission at Antenna Terminals		Pass
§90.209(b)(5)	Bandwidth Limitations		Pass
§90.214	Transient Frequency Behavior		Pass
§90.210	Emission Masks		Pass
§90.210	Radiated Spurious Emissions	Radiated	Pass

**Remark:**

- The analyzer plots shown in this section were all taken with a correction table loaded into the analyzer. The correction table was used to account for the losses of the cables and attenuators used as part of the system to connect the EUT to the analyzer at all frequencies of interest.
- For radiated emission tests, every axis (X, Y, Z) was also verified. The test results shown in the following sections represent the worst-case emissions.

## 5.2. RF Power Output Measurement

### 5.2.1. Test Limit

For assigned frequency band 450.0 ~ 470.0 MHz, the maximum effective radiated power (ERP) shall less than 2.0 W (33 dBm).

### 5.2.2. Test Procedure

ANSI C63.26-2015 Section 5.2.3.2 Measurement of peak power with a peak power meter.

### 5.2.3. Test Setting

Peak power measurements were performed only when the EUT was transmitting at its maximum power control level using a broadband power meter with a pulse sensor. The pulse sensor employs a VBW = 50MHz so this method was only used for signals whose OBW was less than or equal to 50MHz.

### 5.2.4. Test Setup

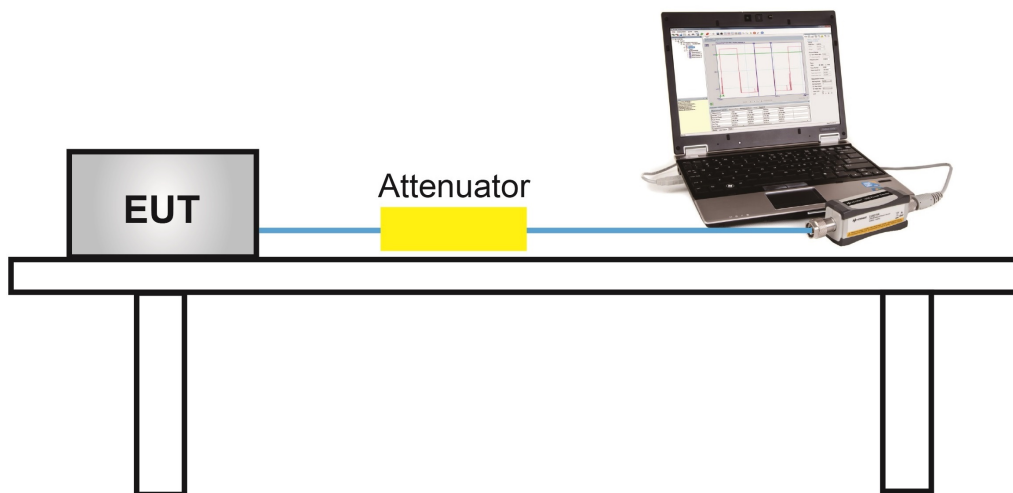

### 5.2.5. Test Result

Refer to Appendix A.

### 5.3. Frequency Stability Measurement

#### 5.3.1. Test Limit

In the 421-512 MHz band, mobile stations designed to operate with a 12.5 kHz channel bandwidth must have a frequency stability of 2.5 ppm.

#### 5.3.2. Test Procedure

ANSI C63.26-2015 - Section 5.6

#### 5.3.3. Test Setting

##### Frequency Stability Under Temperature Variations:

The equipment under test was connected to an external AC or DC power supply and input rated voltage. RF output was connected to a frequency counter or spectrum analyzer via feed through attenuators. The EUT was placed inside the temperature chamber. Set the spectrum analyzer RBW low enough to obtain the desired frequency resolution and measure EUT 20°C operating frequency as reference frequency. Turn EUT off and set the chamber temperature to High. After the temperature stabilized for approximately 30 minutes recorded the frequency. Repeat step measure with 10°C decreased per stage until the Low temperature reached.

##### Frequency Stability Under Voltage Variations:

Set chamber temperature to 20°C. Use a variable AC power supply / DC power source to power the EUT and set the voltage to rated voltage. Set the spectrum analyzer RBW low enough to obtain the desired frequency resolution and recorded the frequency.

Reduce the input voltage to specify extreme voltage variation ( $\pm 15\%$ ) and endpoint, record the maximum frequency change.

For hand carried, battery powered equipment, reduce primary supply voltage to the battery operating end point which shall be specified by the manufacturer.

#### 5.3.4. Test Setup

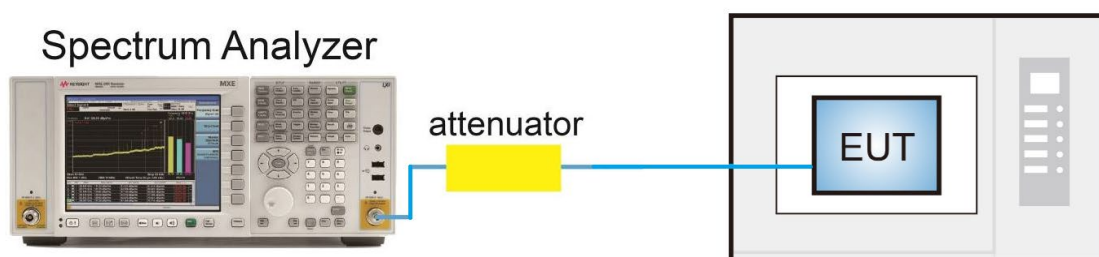

### **5.3.5. Test Result**

Refer to Appendix A.

## **5.4. Modulation Characteristics Measurement**

### **5.4.1. Test Limit**

(a) Voice modulated communication equipment. A curve or equivalent data showing the frequency response of the audio modulating circuit over a range of 100 to 5000 Hz shall be submitted. For equipment required to have an audio low-pass filter, a curve showing the frequency response of the filter, or of all circuitry installed between the modulation limiter and the modulated stage shall be submitted.

(b) Equipment which employs modulation limiting. A curve or family of curves showing the percentage of modulation versus the modulation input voltage shall be supplied. The information submitted shall be sufficient to show modulation limiting capability throughout the range of modulating frequencies and input modulating signal levels employed.

### **5.4.2. Test Procedure**

ANSI C63.26-2015 - Section 5.3

### **5.4.3. Test Setting**

#### **Frequency deviation**

1. Configure the EUT as shown in figure 1, adjust the audio input for 60% of rated system deviation at 1 KHz using this level as a reference (0dB) and vary the input level from -20 to +20dB. Record the frequency deviation obtained as a function of the input level.
2. Repeat step (1) with input frequency changing to 500, 1000, 2500 and 3125Hz in sequence.

#### **Modulation Frequency Response**

1. Configure the EUT as shown in figure 1.
2. Adjust the audio signal generator frequency to the sound pressure level 107dB SPL at the microphone of the EUT.
3. Vary the Audio frequency from 100 Hz to 5 KHz and record the frequency deviation.
4. The peak frequency deviation must not exceed 2.5 KHz.

#### **Audio Frequency Response**

1. Connect the equipment in figure 2.
2. Set the test receiver to measure peak positive deviation. Set the audio bandwidth for  $\leq 50$  Hz to  $\geq 15,000$  Hz. Turn the de-emphasis function off.
3. Adjust the transmitter per the manufacturer's procedure for full rated system deviation.

4. Apply a 1000 Hz tone and adjust the audio frequency generator to produce 20% of the rated system deviation.
5. Set the test receiver to measure rms deviation and record the deviation reading as  $DEV_{REF}$ .
6. Set the audio frequency generator to the desired test frequency between 300 Hz and 3000Hz.
7. Record the test receiver deviation reading as  $DEV_{FREQ}$ .
8. Calculate the audio frequency response at the present frequency as:

$$\text{Audio Frequency Response} = 20 \cdot \log_{10}(DEV_{FREQ} / DEV_{REF})$$

Repeat steps 6 through 8 for all the desired test frequencies.

#### 5.4.4. Test Setup

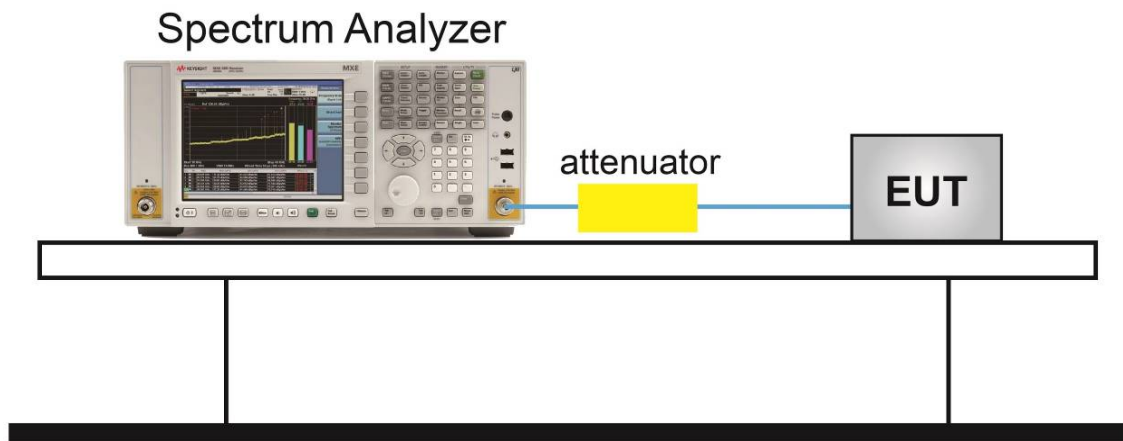

#### 5.4.5. Test Result

Refer to Appendix A.



## 5.5. Occupied Bandwidth Measurement

### 5.5.1. Test Limit

Assigned Frequency (MHz)	Bandwidth Type	Maximum allowed Bandwidth (kHz)
450.0 – 470.0	99%	12.5

### 5.5.2. Test Procedure

ANSI C63.26-2015 - Section 5.4.4

### 5.5.3. Test Setting

1. Span = 1.5 times to 5 times the OBW
2. Set RBW = 1% to 5% the OBW
3. VBW  $\geq 3 \times$  RBW
4. Detector = Peak
5. Trace mode = Max hold
6. Sweep = Auto couple
7. Allow the trace was allowed to stabilize
8. Use the instrument's 99% OBW function to measure

### 5.5.4. Test Setup

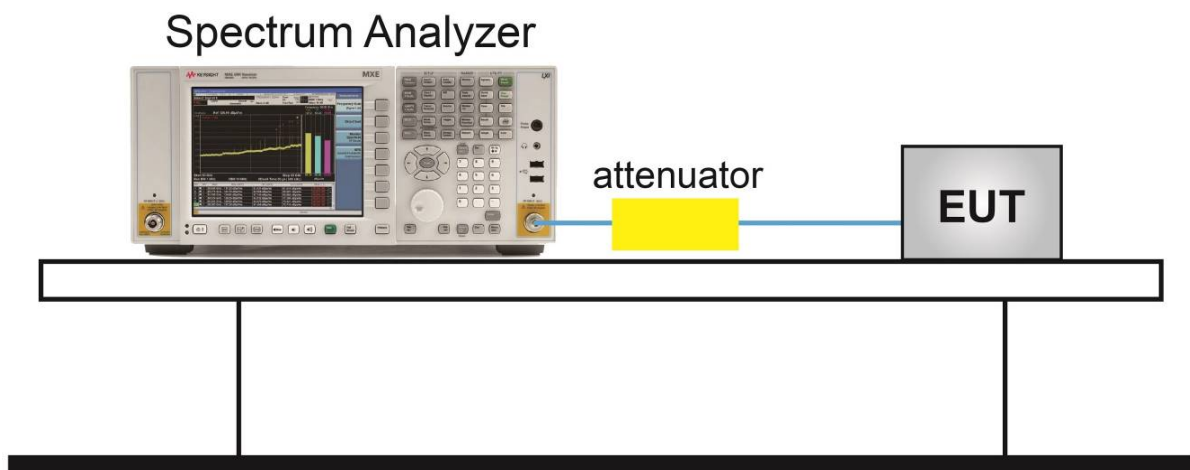

### 5.5.5. Test Result

Refer to Appendix A.

## 5.6. Transient Frequency Behavior Measurement

### 5.6.1. Test Limit

Transmitters designed to operate in the 150-174 MHz and 421-512 MHz frequency bands must maintain transient frequencies within the maximum frequency difference limits during the time intervals indicated:

Time intervals <sup>1 2</sup>	Maximum frequency difference <sup>3</sup>	All equipment	
		150 to 174 MHz	421 to 512 MHz
$t_1^4$	$\pm 12.5$ kHz	5.0 ms	10.0 ms
$t_2$	$\pm 6.25$ kHz	20.0 ms	25.0 ms
$T_3^4$	$\pm 12.5$ kHz	5.0 ms	10.0 ms
Transient Frequency Behavior for Equipment Designed to Operate on 6.25 kHz Channels			
$t_1^4$	$\pm 6.25$ kHz	5.0 ms	10.0 ms
$t_2$	$\pm 3.125$ kHz	20.0 ms	25.0 ms
$T_3^4$	$\pm 6.25$ kHz	5.0 ms	10.0 ms

Note:

<sup>1</sup><sub>on</sub> is the instant when a 1 kHz test signal is completely suppressed, including any capture time due to phasing.

$t_1$  is the time period immediately following  $t_{on}$ .

$t_2$  is the time period immediately following  $t_1$ .

$t_3$  is the time period from the instant when the transmitter is turned off until  $t_{off}$ .

$t_{off}$  is the instant when the 1 kHz test signal starts to rise.

<sup>2</sup> During the time from the end of  $t_2$  to the beginning of  $t_3$ , the frequency difference must not exceed the limits specified in § 90.213.

<sup>3</sup> Difference between the actual transmitter frequency and the assigned transmitter frequency.

<sup>4</sup> If the transmitter carrier output power rating is 6 watts or less, the frequency difference during this time period may exceed the maximum frequency difference for this time period.

### 5.6.2. Test Procedure

ANSI C63.26-2015 - Section 6.5.2.2

### 5.6.3. Test Setting

- a) Connect test equipment as shown in test setup.
- b) Verify RF attenuator power rating for EUT providing adequate protection to the combining network and measurement equipment. Instrumentation linearity shall be confirmed per item j) of 4.2.3.
- c) Tune spectrum analyzer center frequency to EUT frequency and span to at least 100 kHz. Set amplitude according to EUT RF power.
- d) Switch transmitter on and adjust settings in accordance with step c); switch transmitter to the off position.
- e) Set analyzer to FM mode; re-tune analyzer to EUT frequency and span according to step c), while in FM demodulation mode.
- f) An RF test signal of the same frequency as the EUT from the signal generator shall be modulated by a frequency of 1 kHz with a deviation equal to plus or minus the value of the channel spacing (separation). The RF signal strength shall be adjusted allowing the analyzer to demodulate the signal in FM mode.
- g) Adjust analyzer x axis to capture at least 100 ms of demodulated signal.
- h) Adjust analyzer y axis for the correct deviation amplitude.
- i) The analyzer display should show a continuous 1 kHz signal and the channel spacing deviation amplitude.
- j) Change analyzer settings to single sweep and external trigger. For newer analyzers, the channel bandwidth might have to be adjusted for the correct sample rate and sweep speed.
- k) Turn on EUT and adjust analyzer to display desired signal by adjusting trigger settings and considerations in step j). Turn off EUT.
- l) Repeat step k) until optimum set-up is achieved.
- m) Start measurement by turning on EUT. Observe measurements results in analyzer display, EUTON starts at the moment the 1 kHz signal is suppressed ( $t_2$ ). See Figure 11 for transient frequency behavior with switch on.
- n) Record values observed in step m) as frequency difference versus time.
- o) Turn off EUT. EUT OFF is considered at the start of the 1 kHz signal defined as  $t_3$ . See Figure 12 for transient frequency behavior with switch off.
- p) Record the values observed in step o) as frequency difference versus time.

#### 5.6.4. Test Setup

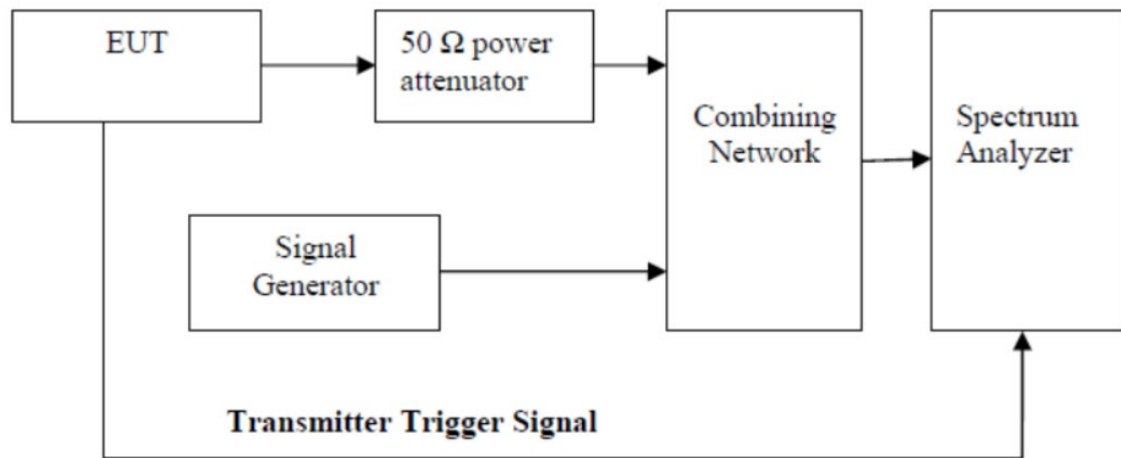

#### 5.6.5. Test Result

Refer to Appendix A.

## 5.7. Emission Mask Measurement

### 5.7.1. Test Limit

For transmitters designed to operate with a 12.5 kHz channel bandwidth, any emission must be attenuated below the power (P) of the highest emission contained within the authorized bandwidth as follows:

- (1) On any frequency from the center of the authorized bandwidth  $f_0$  to 5.625 kHz removed from  $f_0$ : Zero dB.
- (2) On any frequency removed from the center of the authorized bandwidth by a displacement frequency ( $f_d$  in kHz) of more than 5.625 kHz but no more than 12.5 kHz: At least  $7.27(f_d - 2.88 \text{ kHz})$  dB.
- (3) On any frequency removed from the center of the authorized bandwidth by a displacement frequency ( $f_d$  in kHz) of more than 12.5 kHz: At least  $50 + 10 \log(P)$  dB or 70 dB, whichever is the lesser attenuation.
- (4) The reference level for showing compliance with the emission mask shall be established using a resolution bandwidth sufficiently wide (usually two or three times the channel bandwidth) to capture the true peak emission of the equipment under test. In order to show compliance with the emission mask up to and including 50 kHz removed from the edge of the authorized bandwidth, adjust the resolution bandwidth to 100 Hz with the measuring instrument in a peak hold mode. A sufficient number of sweeps must be measured to insure that the emission profile is developed. If video filtering is used, its bandwidth must not be less than the instrument resolution bandwidth. For emissions beyond 50 kHz from the edge of the authorized bandwidth. If it can be shown that use of the above instrumentation settings do not accurately represent the true interference potential of the equipment under test, an alternate procedure may be used provided prior Commission approval is obtained.

### 5.7.2. Test Procedure

ANSI C63.26-2015 - Section 5.7.2

### 5.7.3. Test Setting

1. Connect the EUT antenna output port to the spectrum analyzer via an appropriate RF cable.
2. Analyzer was set to the center frequency of the EUT channel under investigation
3. Span  $\geq 1.5$  times the OBW
4. Set the RBW as required by applicable regulations.
5. VBW to a value  $\geq 3 \times$  RBW
6. Detector = Peak
7. Sweep time = auto couple
8. Trace mode = max hold
9. Trace was allowed to stabilize

#### 5.7.4. Test Setup

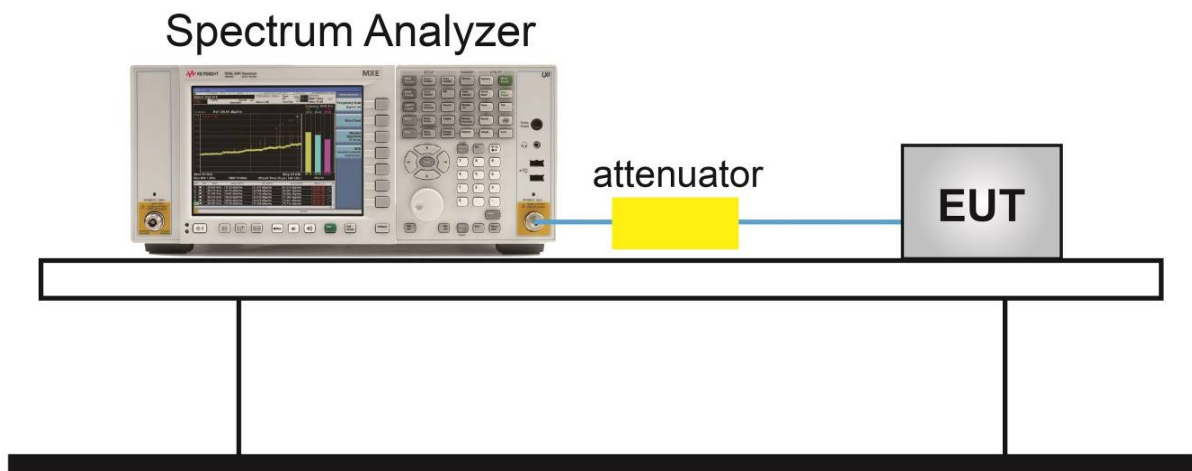

#### 5.7.5. Test Result

Refer to Appendix A.

## 5.8. Radiated Spurious Emission Measurement

### 5.8.1. Test Limit

For transmitters that are equipped with an audio low-pass filter, the power of any emission must be attenuated below the unmodulated carrier power (P) as follows:

On any frequency removed from the assigned frequency by more than 250 percent of the authorized bandwidth: At least  $50 + 10 \log (P)$  dB. The emission limit equal to  $-20\text{dBm}$ .

$E (\text{dB}\mu\text{V}/\text{m}) = \text{EIRP} (\text{dBm}) - 20 \log D + 104.8$ ; where D is the measurement distance in meters. The emission limit equal to  $75.3\text{dB}\mu\text{V}/\text{m}$ .

### 5.8.2. Test Procedure

ANSI C63.26-2015 - Section 5.5.4

### 5.8.3. Test Setting

1. RBW = 1MHz
2. VBW  $\geq 3 \times \text{RBW}$
3. Sweep time  $\geq 10 \times (\text{number of points in sweep}) \times (\text{transmission symbol period})$
4. Detector = Peak
5. Trace mode = max hold
6. The trace was allowed to stabilize

### 5.8.4. Test Setup

Below 1GHz Test Setup:

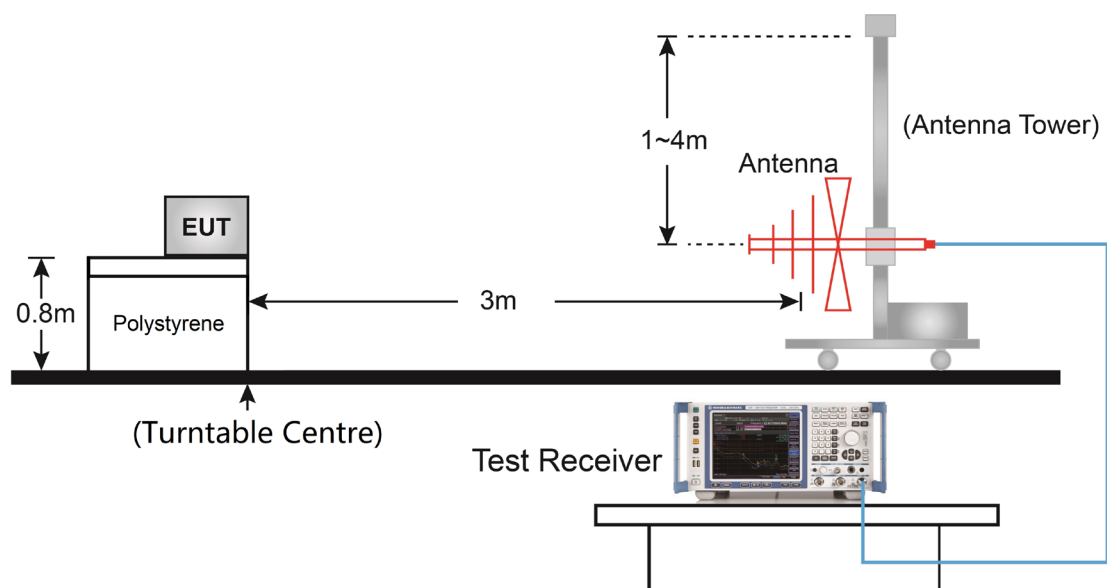

Above 1GHz Test Setup:

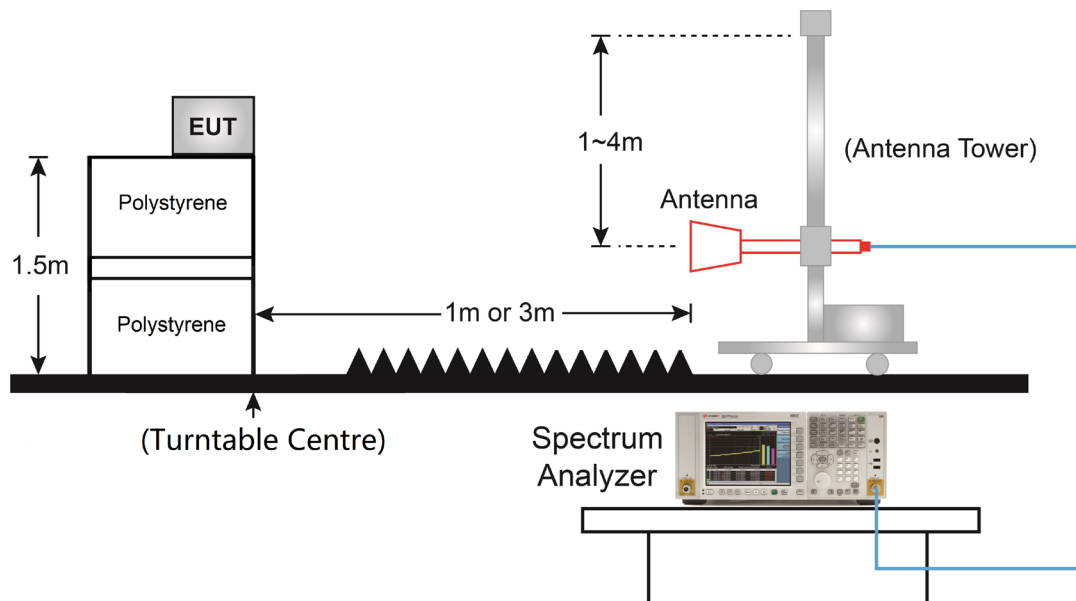

**5.8.5. Test Result**

Refer to Appendix A.



## Appendix A – Test Result

### A.1 RF Power Output Test Result

Test Site	WZ-SR5	Test Engineer	Liz Yuan
Test Date	2021/12/25		

Channel No.	Frequency (MHz)	Measured Output Power (dBm)	Measured Output Power (mW)	Limit (mW)	Result
3	461.0375	32.30	1.70	2.00	Pass
9	464.5500	31.98	1.58	2.00	Pass
2	467.9250	31.87	1.54	2.00	Pass

**A.2 Frequency Stability Test Result**

Test Site	WZ-SR5	Test Engineer	Liz Yuan
Test Date	2022/01/18		

**Frequency Stability versus input normal voltage**

Voltage (V)	Temp (°C)	Frequency Tolerance (ppm)	Limit (ppm)
7.4	-30	-0.66	±2.5
	-20	-0.42	±2.5
	-10	-0.23	±2.5
	0	-0.57	±2.5
	+ 10	-0.31	±2.5
	+ 20	-0.64	±2.5
	+ 30	-0.41	±2.5
	+ 40	-0.20	±2.5
	+ 50	-0.49	±2.5
Endpoint voltage (V)	Temp (°C)	Frequency Tolerance (ppm)	Limit (ppm)
6.1 <sup>Note</sup>	20	-0.43	±2.5

Note: Battery terminal voltage is declared and specified by the manufacturer.

**A.3 Audio Frequency Response Test Result**

Test Site	WZ-SR5	Test Engineer	Liz Yuan
Test Date	2022/01/18		

Frequency (Hz)	Deviation (kHz)	Audio Frequency Response (dB)
300	0.13	-11.70
400	0.16	-9.90
500	0.21	-7.54
600	0.27	-5.35
700	0.32	-3.88
800	0.37	-2.62
900	0.44	-1.11
1000	0.5	0.00
1100	0.56	0.98
1200	0.6	1.58
1300	0.63	2.01
1400	0.68	2.67
1500	0.72	3.17
1600	0.76	3.64
1700	0.83	4.40
1800	0.86	4.71
1900	0.92	5.30
2000	0.95	5.58
2100	0.98	5.85
2200	1.03	6.28
2300	1.05	6.44
2400	1.06	6.53
2500	1.12	7.00
2600	1.15	7.23
2700	1.17	7.38
2800	1.1	6.85
2900	1.04	6.36
3000	1.05	6.44

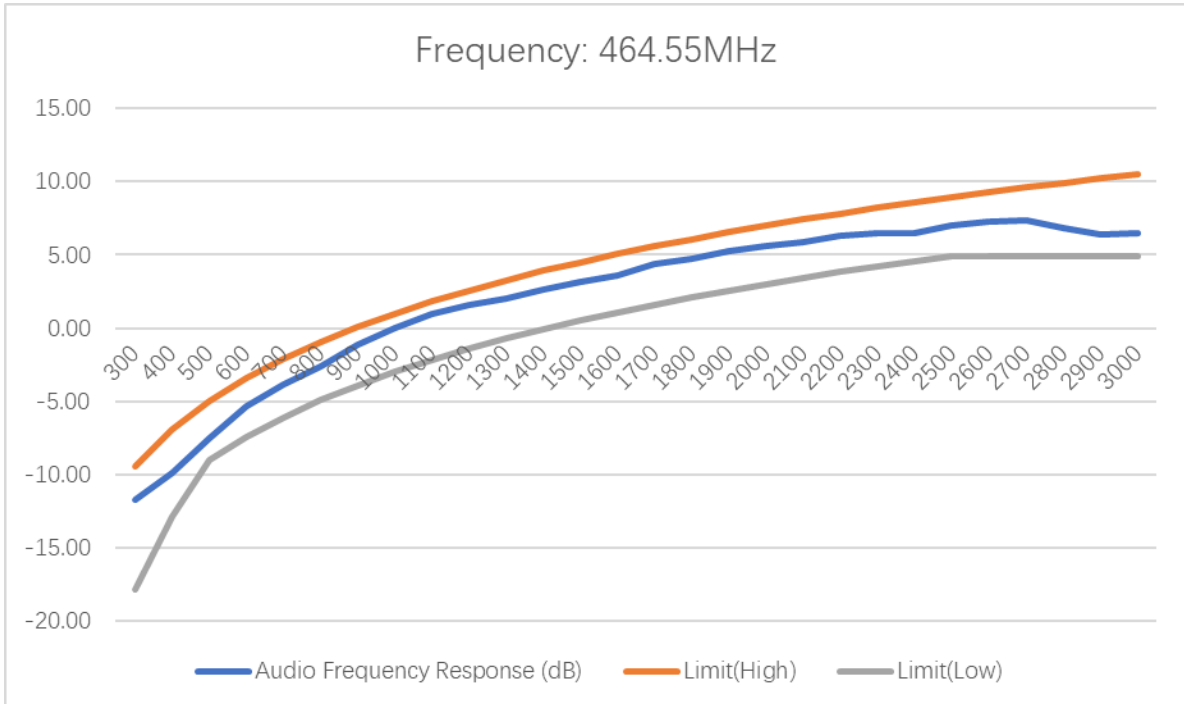

**A.4 Modulation Limiting Test Result**

Test Site	WZ-SR5	Test Engineer	Liz Yuan
Test Date	2022/01/18		

Modulation Level (dB)	Peak Freq. Deviation at 300Hz	Peak Freq. Deviation at 1000Hz	Peak Freq. Deviation at 1500Hz	Peak Freq. Deviation at 3000Hz
-20	0.18	0.08	0.23	0.33
-15	0.29	0.10	0.41	0.56
-10	0.50	0.16	0.73	0.96
-5	0.86	0.26	1.29	1.46
0	1.50	0.44	2.10	1.52
5	2.24	0.73	2.24	1.51
10	2.34	0.79	2.25	1.5
15	2.41	0.94	2.24	1.54
20	2.4	1.05	2.25	1.56

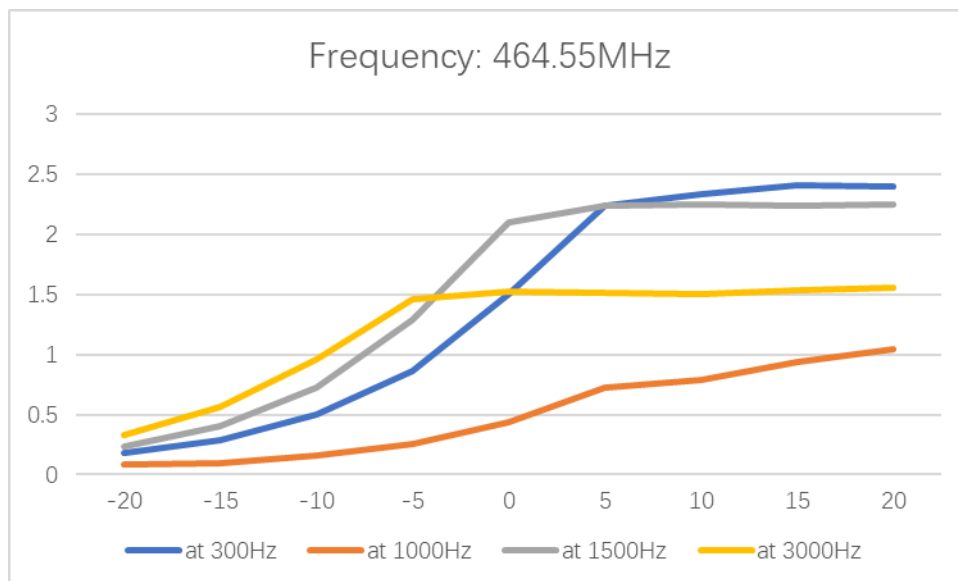

**A.5 Occupied Bandwidth Test Result**

Test Site	WZ-SR5	Test Engineer	Liz Yuan
Test Date	2022/01/19		

Channel No.	Frequency (MHz)	99% Bandwidth (MHz)	Limit (KHz)	Result
03	461.0375	9.911	≤ 12.5	Pass
01	464.5500	9.885	≤ 12.5	Pass
02	467.9250	9.916	≤ 12.5	Pass

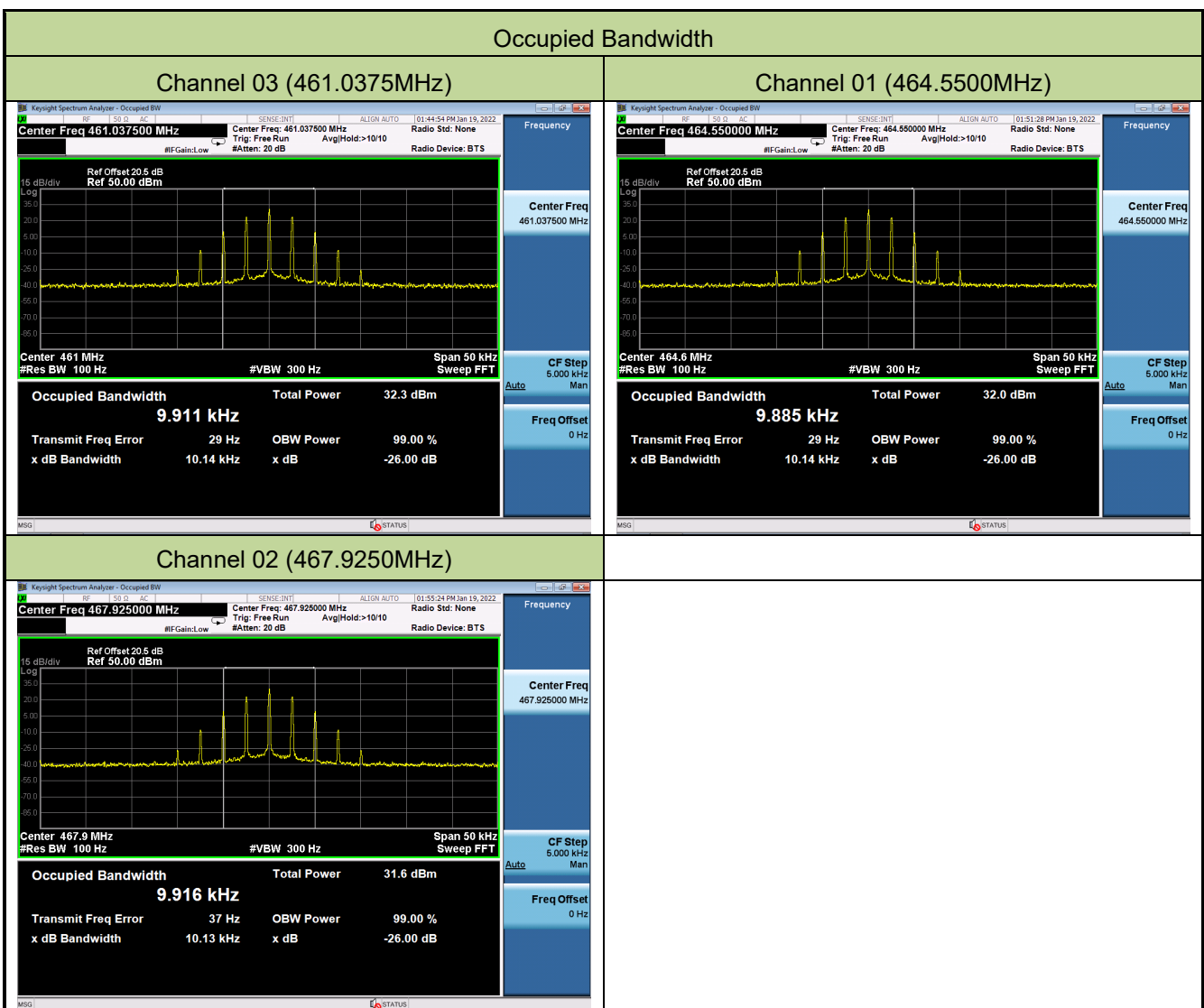

**A.6 Transient Frequency Behavior Test Result**

Test Site	WZ-SR5	Test Engineer	Liz Yuan
Test Date	2022/01/27		

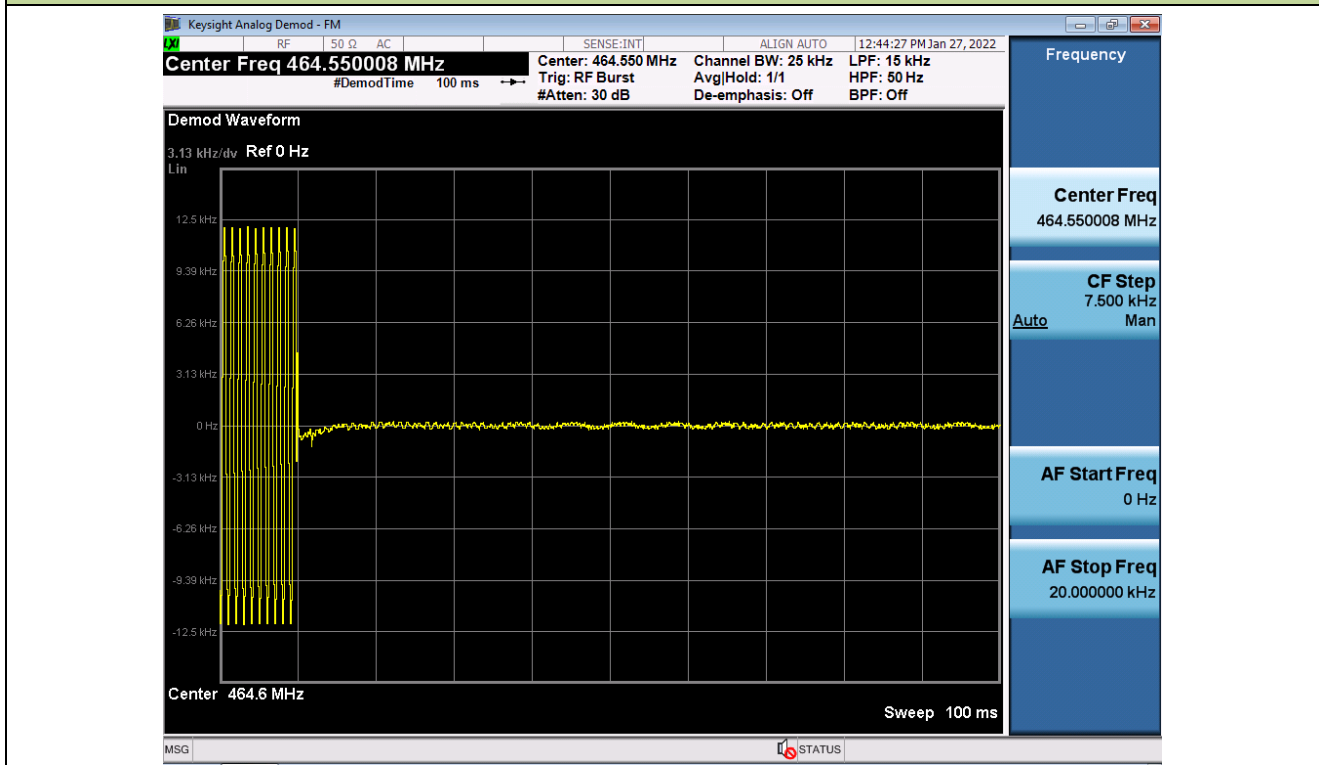
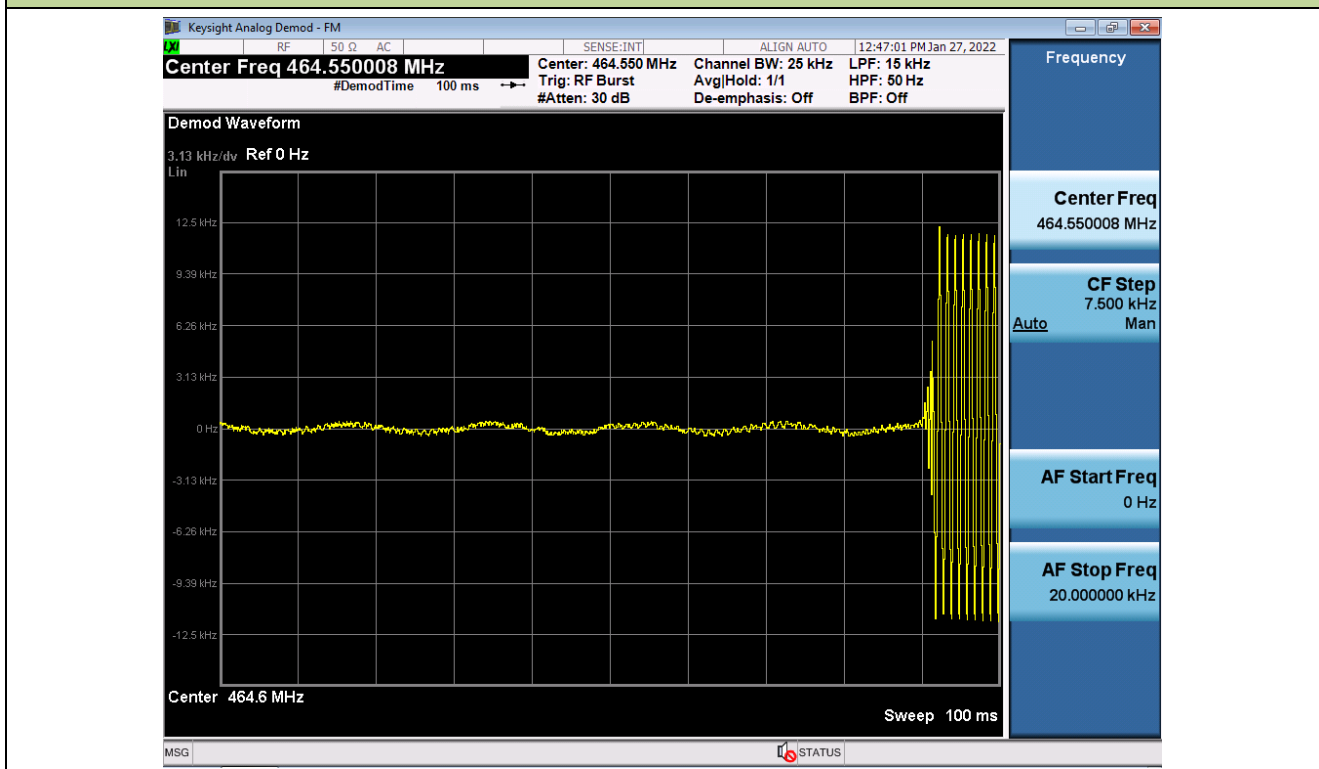
**Transmitter Frequency Behavior – off to on**

**Transmitter Frequency Behavior – on to off**

### A.7 Emission Mask Test Result

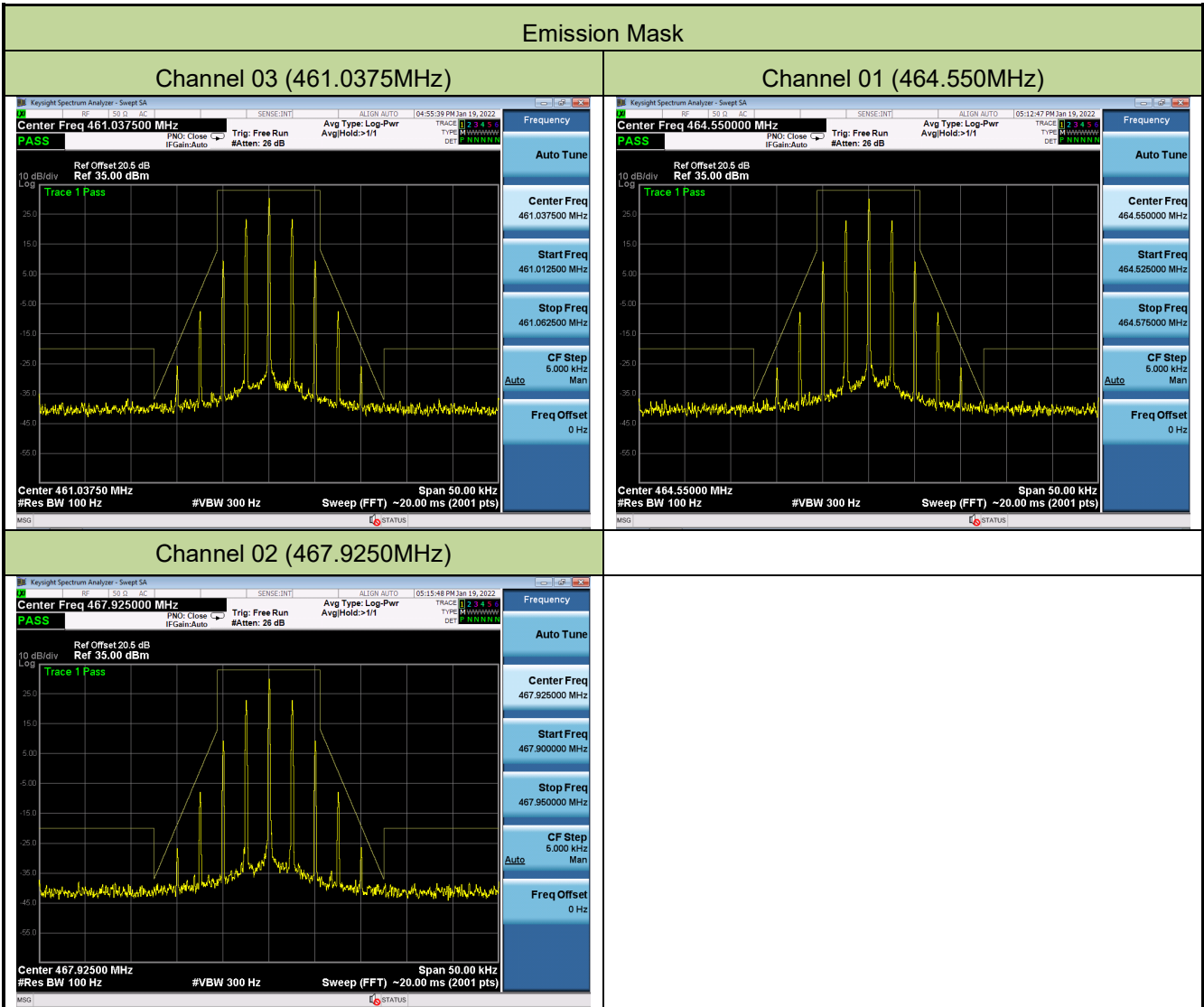
Test Site	WZ-SR5	Test Engineer	Liz Yuan
Test Date	2022/01/19		





### A.8 Conducted Spurious Emission Test Result

Test Site	WZ-SR5	Test Engineer	Liz Yuan
Test Date	2022/01/21		

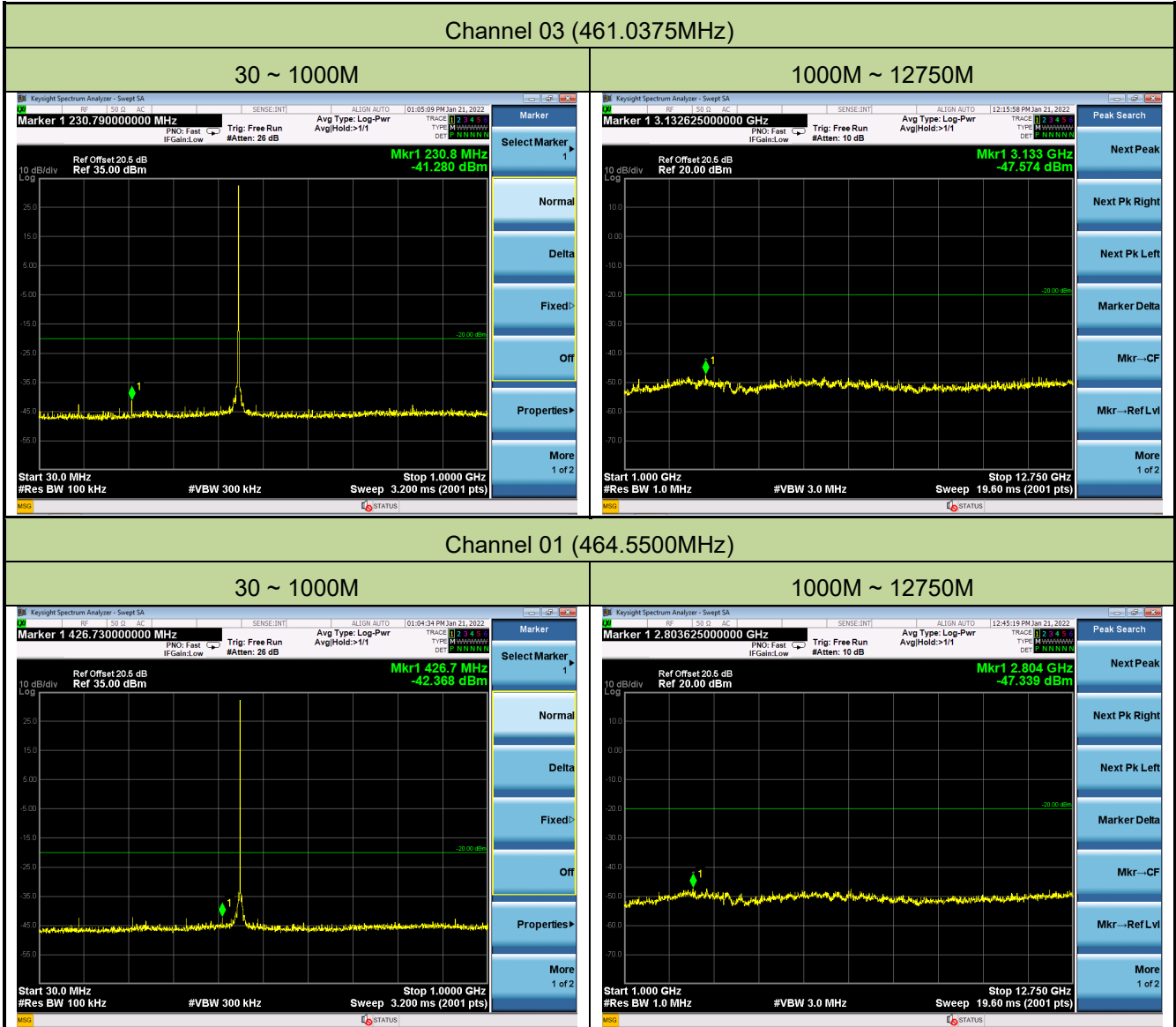

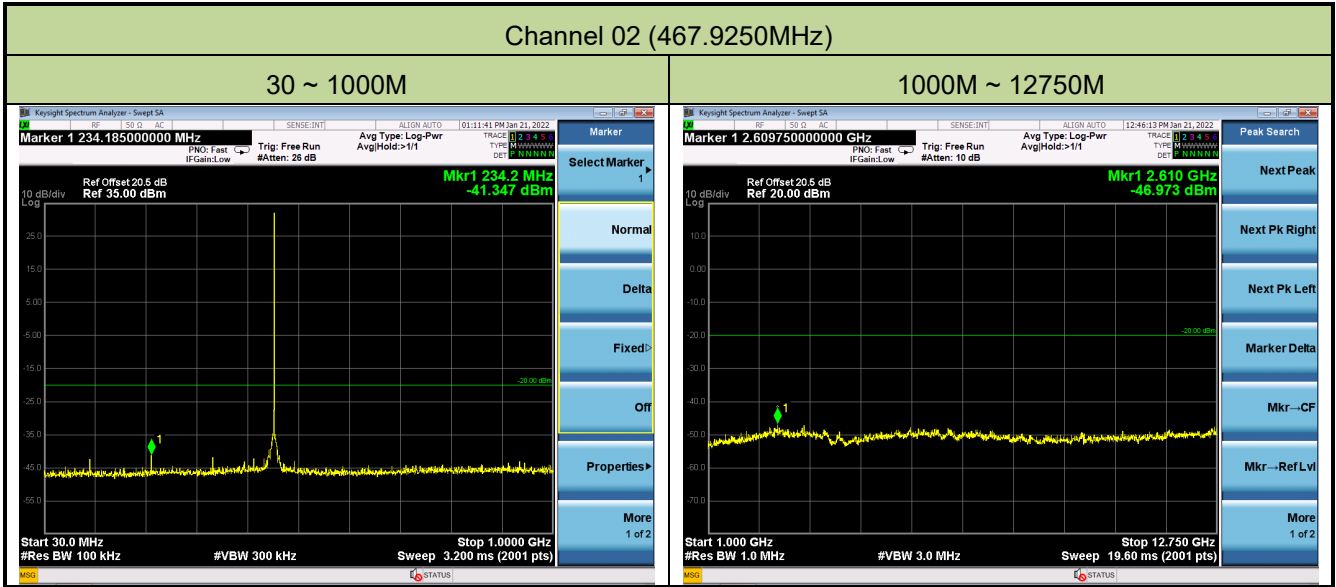

**A.9 Spurious Emission Test Result**

Test Site	WZ-AC1	Test Engineer	Kin Xia
Test Date	2022/03/01		

Channel	Frequency (MHz)	Reading Level (dB $\mu$ V)	Factor (dB/m)	Measure Level (dB $\mu$ V/m)	Limit (dB $\mu$ V/m)	Margin (dB)	Detector	Polarization
03	422.9	18.4	21.4	39.8	75.3	-35.5	Peak	Horizontal
	803.6	13.6	28.6	42.2	75.3	-33.1	Peak	Horizontal
	576.1	20.2	25.0	45.2	75.3	-30.1	Peak	Vertical
	921.9	41.5	30.0	71.5	75.3	-3.8	Peak	Vertical
	2793.5	40.9	-1.6	39.3	75.3	-36.0	Peak	Horizontal
	3873.0	38.5	1.3	39.8	75.3	-35.5	Peak	Horizontal
	3184.5	38.2	-0.2	38.0	75.3	-37.3	Peak	Vertical
	4298.0	37.4	2.5	39.9	75.3	-35.4	Peak	Vertical
01	166.3	12.2	17.8	30.0	75.3	-45.3	Peak	Horizontal
	758.0	13.3	28.1	41.4	75.3	-33.9	Peak	Horizontal
	232.2	20.3	15.0	35.3	75.3	-40.0	Peak	Vertical
	929.2	20.6	30.0	50.6	75.3	-24.7	Peak	Vertical
	3252.5	42.2	-0.2	42.0	75.3	-33.3	Peak	Horizontal
	4179.0	38.0	1.9	39.9	75.3	-35.4	Peak	Horizontal
	3159.0	39.1	-0.2	38.9	75.3	-36.4	Peak	Vertical
	3720.0	38.2	0.8	39.0	75.3	-36.3	Peak	Vertical
02	429.6	17.7	21.7	39.4	75.3	-35.9	Peak	Horizontal
	936.0	15.6	30.0	45.6	75.3	-29.7	Peak	Horizontal
	234.2	22.7	15.3	38.0	75.3	-37.3	Peak	Vertical
	936.0	41.5	30.0	71.5	75.3	-3.8	Peak	Vertical
	3278.0	41.0	-0.3	40.7	75.3	-34.6	Peak	Horizontal
	4740.0	37.4	3.5	40.9	75.3	-34.4	Peak	Horizontal
	3278.0	40.6	-0.3	40.3	75.3	-35.0	Peak	Vertical
	4714.5	36.9	3.5	40.4	75.3	-34.9	Peak	Vertical

Note: Measure Level (dB $\mu$ V/m) = Reading Level (dB $\mu$ V) + Factor (dB/m).

## **Appendix B – Test Setup Photograph**

Refer to “2111RSU076-UT” file.

## Appendix C – EUT Photograph

Refer to “2111RSU076-UE” file.