



SAR TEST REPORT

HCT CO., LTD



EUT Type:	Cellular/PCS GSM Phone(850/1800/1900) GPRS Class 12 and GPRS mode class B(GPRS and GSM, but not simultaneously)				
FCC ID:	WVBQS100				
Model:	QS100	Trade Name	Brightstar		
Date of Issue:	Jul.19, 2009				
Test report No.:	HCT-IA0907-0203				
Test Laboratory:	HCT CO., LTD. SAN 136-1, AMI-RI, BUBAL-EUP, ICHEON-SI, KYOUNGKI-DO, 467-701, KOREA TEL: +82 31 639 8565 FAX: +82 31 639 8525				
Applicant :	Brightstar Corp. 9725 NW 117 th Avenue, #300 1Miami, FL 33178 USA				
Testing has been carried out in accordance with:	47CFR §2.1093 FCC OET Bulletin 65(Edition 97-01), Supplement C (Edition 01-01) ANSI/ IEEE C95.1 – 2005 IEEE 1528-2003				
Test result:	The tested device complies with the requirements in respect of all parameters subject to the test. The test results and statements relate only to the items tested. The test report shall not be reproduced except in full, without written approval of the laboratory.				
Signature	 _____ Report prepared by : Sun-Hee Kim Test Engineer of SAR Part			 _____ Approved by : Jae-Sang So Manager of SAR Part	

Table of Contents

<u>1. INTRODUCTION</u>	3
<u>2. DESCRIPTION OF DEVICE</u>	4
<u>3. DESCRIPTION OF TEST EQUIPMENT</u>	5
<u>3.1 SAR MEASUREMENT SETUP</u>	5
<u>3.2 DASY E-FIELD PROBE SYSTEM</u>	6
<u>3.3 PROBE CALIBRATION PROCESS</u>	7
<u>3.4 SAM Phantom</u>	9
<u>3.5 Device Holder for Transmitters</u>	9
<u>3.6 Brain & Muscle Simulating Mixture Characterization</u>	10
<u>3.7 SAR TEST EQUIPMENT</u>	11
<u>4. SAR MEASUREMENT PROCEDURE</u>	12
<u>5. DESCRIPTION OF TEST POSITION</u>	13
<u>5.1 HEAD POSITION</u>	13
<u>5.2 Body Holster/Belt Clip Configurations</u>	14
<u>6. MEASUREMENT UNCERTAINTY</u>	15
<u>7. ANSI/ IEEE C95.1 - 2005 RF EXPOSURE LIMITS</u>	16
<u>8. SYSTEM VERIFICATION</u>	17
<u>8.1 Tissue Verification</u>	17
<u>8.2 System Validation</u>	17
<u>9. RF CONDUCTED POWER</u>	18
<u>9.1 Procedures Used to Establish RF Signal for SAR</u>	18
<u>10. SAR TEST DATA SUMMARY</u>	19
<u>10.1 Measurement Results (GSM850 Head SAR Touch)</u>	19
<u>10.2 Measurement Results (GSM850 Head SAR Tilt)</u>	20
<u>10.3 Measurement Results (GSM1900 Head SAR Touch)</u>	21
<u>10.4 Measurement Results (GSM1900 Head SAR Tilt)</u>	22
<u>10.5 Measurement Results (GSM850 Body SAR)</u>	23
<u>10.6 Measurement Results (GSM1900 Body SAR)</u>	24
<u>11. CONCLUSION</u>	25
<u>12. REFERENCES</u>	26
Attachment 1. – SAR Test Plots	27
Attachment 2. – Dipole Validation Plots	56
Attachment 3. – Probe Calibration Data	63
Attachment 4. – Dipole Calibration Data	73

1. INTRODUCTION

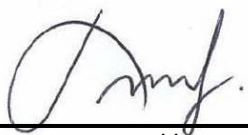
The FCC has adopted the guidelines for evaluating the environmental effects of radio frequency radiation in ET Docket 93-62 on Aug. 6, 1996 to protect the public and workers from the potential hazards of RF emissions due to FCC-regulated portable devices.

The safety limits used for the environmental evaluation measurements are based on the criteria published by the American National Standards Institute (ANSI) for localized specific absorption rate (SAR) in IEEE/ANSI C95.1-2005 Standard for Safety Levels with Respect to Human Exposure to Radio Frequency Electromagnetic Fields, 3 kHz to 300 GHz. 1992 by the Institute of Electrical and Electronics Engineers, Inc., New York, New York 10017. The measurement procedure described in IEEE/ANSI C95.3-1992 Recommended Practice for the Measurement of Potentially Hazardous Electromagnetic Fields - RF and Microwave is used for guidance in measuring SAR due to the RF radiation exposure from the Equipment Under Test (EUT). These criteria for SAR evaluation are similar to those recommended by the National Council on Radiation Protection and Measurements (NCRP) in Biological Effects and Exposure Criteria for Radio frequency Electromagnetic Fields," NCRP Report No. 86 NCRP, 1986, Bethesda, MD 20814. SAR is a measure of the rate of energy absorption due to exposure to an RF transmitting source. SAR values have been related to threshold levels for potential biological hazards.

SAR Definition

Specific Absorption Rate (SAR) is defined as the time derivative of the incremental electromagnetic energy (dW) absorbed by (dissipated in) an incremental mass (dm) contained in a volume element (dV) of a given density (r). It is also defined as the rate of RF energy absorption per unit mass at a point in an absorbing body.

$$SAR = \frac{d}{dt} \left(\frac{dU}{dm} \right) = \frac{d}{dt} \left(\frac{dU}{\rho dV} \right)$$

Figure 2. SAR Mathematical Equation

SAR is expressed in units of Watts per Kilogram (W/kg).

$$SAR = \sigma E^2 / \rho$$

where:

- σ = conductivity of the tissue-simulant material (S/m)
- ρ = mass density of the tissue-simulant material (kg/m³)
- E = Total RMS electric field strength (V/m)

NOTE: The primary factors that control rate of energy absorption were found to be the wavelength of the incident field in relations to the dimensions and geometry of the irradiated organism, the orientation of the organism in relation to the polarity of field vectors, the presence of reflecting surfaces, and whether conductive contact is made by the organism with a ground plane.

2. DESCRIPTION OF DEVICE

Environmental evaluation measurements of specific absorption rate (SAR) distributions in emulated human head and body tissues exposed to radio frequency (RF) radiation from wireless portable devices for compliance with the rules and regulations of the U.S. Federal Communications Commission (FCC).

EUT Type	Cellular/PCS GSM Phone(850/1800/1900) GPRS Class 12 and GPRS mode class B(GPRS and GSM, but not simultaneously)
FCC ID	WVBS100
Model(s)	QS100
Trade Name	Brightstar Corp.
Serial Number(s)	#1
Application Type	Certification
Modulation(s)	GSM850/GSM1900
Tx Frequency	824.20 - 848.80 MHz (GSM850) 1 850.20 – 1 909.80 MHz (GSM1900)
Rx Frequency	869.20 - 893.80 MHz (GSM850) 1 930.20 – 1 989.80 MHz (GSM1900)
FCC Classification	Licensed Portable Transmitter Held to Ear (PCE)
Production Unit or Identical Prototype	Prototype
Max SAR	0.993 W/kg GSM850 Head SAR / 1.36 W/kg GSM850 Body SAR 0.664 W/kg GSM1900 Head SAR / 0.765 W/kg GSM1900 Body SAR
Date(s) of Tests	Jul. 12, 2009 ~ Jul. 13, 2009
Antenna Type	Intenna

3. DESCRIPTION OF TEST EQUIPMENT

3.1 SAR MEASUREMENT SETUP

These measurements are performed using the DASY4 automated dosimetric assessment system. It is made by Schmid & Partner Engineering AG (SPEAG) in Zurich, Switzerland. It consists of high precision robotics system (Staubli), robot controller, Pentium III computer, near-field probe, probe alignment sensor, and the generic twin phantom containing the brain equivalent material. The robot is a six-axis industrial robot performing precise movements to position the probe to the location (points) of maximum electromagnetic field (EMF) (see Figure.3.1).

A cell controller system contains the power supply, robot controller, teach pendant (Joystick), and remote control, is used to drive the robot motors. The PC consists of the HP Pentium IV 3.0 GHz computer with Windows XP system and SAR Measurement Software DASY4, A/D interface card, monitor, mouse, and keyboard. The Staubli Robot is connected to the cell controller to allow software manipulation of the robot. A data acquisition electronic (DAE) circuit performs the signal amplification, signal multiplexing, AD-conversion, offset measurements, mechanical surface detection, collision detection, etc. is connected to the Electro-optical coupler (EOC). The EOC performs the conversion from the optical into digital electric signal of the DAE and transfers data to the PC plug-in card.

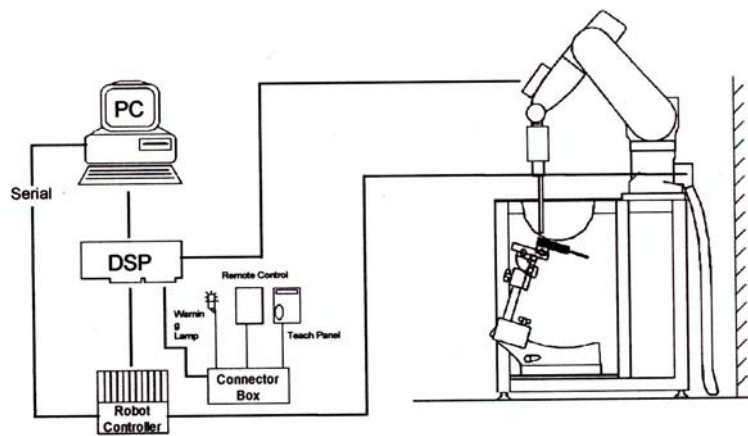

Figure 3.1 HCT SAR Lab. Test Measurement Set-up

The DAE4 consists of a highly sensitive electrometer-grade preamplifier with auto-zeroing, a channel and gain-switching multiplexer, a fast 16 bit AD-converter and a command decoder and control logic unit. Transmission to the PC-card is accomplished through an optical downlink for data and status information and an optical uplink for commands and clock lines. The mechanical probe mounting device includes two different sensor systems for frontal and sidewise probe contacts. They are also used for mechanical surface detection and probe collision detection. The robot uses its own controller with a built in VME-bus computer. The system is described in detail in.

3.2 DASY E-FIELD PROBE SYSTEM

3.2.1 ET3DV6 Probe Specification

Construction	Symmetrical design with triangular core Built-in optical fiber for surface detection System Built-in shielding against static charges
Calibration	In air from 10 MHz to 2.5 GHz In brain and muscle simulating tissue at Frequencies of 450 MHz, 900 MHz and 1.8 GHz (accuracy: 8 %)
Frequency	10 MHz to > 6 GHz; Linearity: ± 0.2 dB (30 MHz to 3 GHz)
Directivity	± 0.2 dB in brain tissue (rotation around probe axis) ± 0.4 dB in brain tissue (rotation normal probe axis)
Dynamic	5 μ W/g to > 100 mW/g;
Range Linearity:	± 0.2 dB
Surface Detection	± 0.2 mm repeatability in air and clear liquids over diffuse reflecting surfaces.
Dimensions	Overall length: 330 mm Tip length: 16 mm Body diameter: 12 mm Tip diameter: 6.8 mm Distance from probe tip to dipole centers: 2.7 mm
Application	General dissymmetry up to 3 GHz Compliance tests of mobile phones Fast automatic scanning in arbitrary phantoms

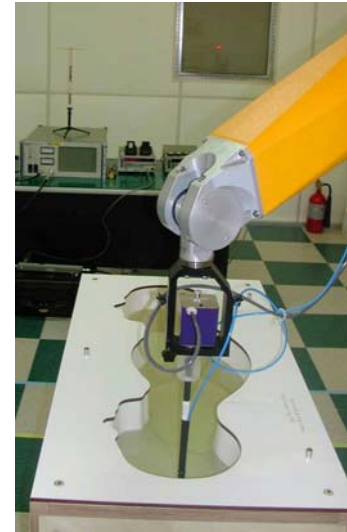

Figure 3.2 Photograph of the probe and the Phantom



Figure 3.3 ET3DV6 E-field Probe

The SAR measurements were conducted with the dosimetric probe ET3DV6, designed in the classical triangular configuration and optimized for dosimetric evaluation. The probe is constructed using the thick film technique; with printed resistive lines on ceramic substrates. The probe is equipped with an optical multifiber line ending at the front of the probe tip. It is connected to the EOC box on the robot arm and provides an automatic detection of the phantom surface. Half of the fibers are connected to a pulsed infrared transmitter, the other half to a synchronized receiver. As the probe approaches the surface, the reflection from the surface produces a coupling from the transmitting to the receiving fibers. This reflection increases first during the approach, reaches a maximum and then decreases. If the probe is flatly touching the surface, the coupling is zero. The distance of the coupling maximum to the surface is independent of the surface reflectivity and largely independent of the surface to probe angle. The DASY4 software reads the reflection during a software approach and looks for the maximum using a 2nd order fitting. The approach is stopped at reaching the maximum.

3.3 PROBE CALIBRATION PROCESS

3.3.1 E-Probe Calibration

Each probe is calibrated according to a dosimetric assessment procedure with an accuracy better than ± 10 %. The spherical isotropy was evaluated with the proper procedure and found to be better than ± 0.25 dB. The sensitivity parameters (NormX, NormY, NormZ), the diode compression parameter (DCP) and the conversion factor (ConvF) of the probe is tested.

The free space E-field from amplified probe outputs is determined in a test chamber. This is performed in a TEM cell for frequencies bellow 1 GHz, and in a waveguide above 1 GHz for free space. For the free space calibration, the probe is placed in the volumetric center of the cavity and at the proper orientation with the field. The probe is then rotated 360 degrees.

E-field temperature correlation calibration is performed in a flat phantom filled with the appropriate simulated brain tissue. The measured free space E-field in the medium correlates to temperature rise in a dielectric medium. For temperature correlation calibration a RF transparent thermistor-based temperature probe is used in conjunction with the E-field probe.

$$SAR = C \frac{\Delta T}{\Delta t}$$

where:

- Δt = exposure time (30 seconds),
- C = heat capacity of tissue (brain or muscle),
- ΔT = temperature increase due to RF exposure.

SAR is proportional to $\Delta T / \Delta t$, the initial rate of tissue heating, before thermal diffusion takes place. Now it's possible to quantify the electric field in the simulated tissue by equating the thermally derived SAR to the E- field;

$$SAR = \frac{|E|^2 \cdot \sigma}{\rho}$$

where:

- σ = simulated tissue conductivity,
- ρ = Tissue density (1.25 g/cm³ for brain tissue)

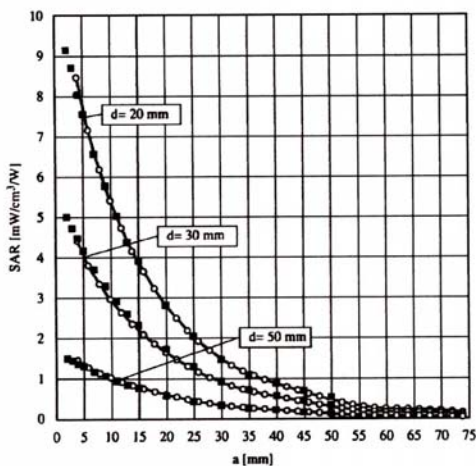

Figure 3.4 E-Field and Temperature measurements at 900 MHz

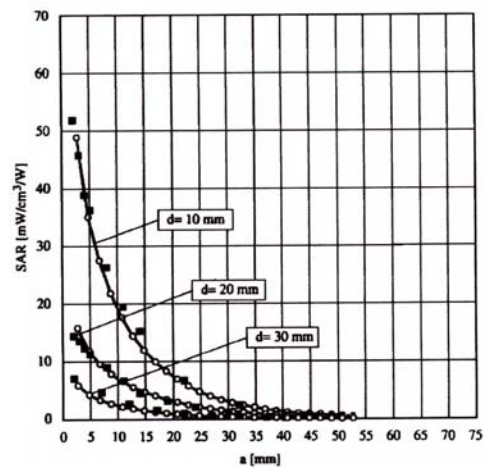

Figure 3.5 E-Field and temperature measurements at 1.8 GHz

3.3.2 Data Extrapolation

The DASY4 software automatically executes the following procedures to calculate the field units from the microvolt readings at the probe connector. The first step of the evaluation is a linearization of the filtered input signal to account for the compression characteristics of the detector diode. The compensation depends on the input signal, the diode type and the DC-transmission factor from the diode to the evaluation electronics. If the exciting field is pulsed, the crest factor of the signal must be known to correctly compensate for peak power. The formula for each channel can be given like below;

$$V_i = U_i + U_i^2 \cdot \frac{cf}{dcp_i}$$

with V_i = compensated signal of channel i (i=x,y,z)
 U_i = input signal of channel i (i=x,y,z)
 cf = crest factor of exciting field (DASY parameter)
 dcp_i = diode compression point (DASY parameter)

From the compensated input signals the primary field data for each channel can be evaluated:

E-field probes:

$$E_i = \sqrt{\frac{V_i}{Norm_i \cdot ConvF}}$$

with V_i = compensated signal of channel i (i = x,y,z)
 $Norm_i$ = sensor sensitivity of channel i (i = x,y,z)
 $\mu V/(V/m)^2$ for E-field probes
 $ConvF$ = sensitivity of enhancement in solution
 E_i = electric field strength of channel i in V/m

The RSS value of the field components gives the total field strength (Hermetian magnitude):

$$E_{tot} = \sqrt{E_x^2 + E_y^2 + E_z^2}$$

The primary field data are used to calculate the derived field units.

$$SAR = E_{tot}^2 \cdot \frac{\sigma}{\rho \cdot 1000}$$

with SAR = local specific absorption rate in W/g
 E_{tot} = total field strength in V/m
 σ = conductivity in [mho/m] or [Siemens/m]
 ρ = equivalent tissue density in g/cm³

The power flow density is calculated assuming the excitation field to be a free space field.

$$P_{pwe} = \frac{E_{tot}^2}{3770}$$

with P_{pwe} = equivalent power density of a plane wave in W/cm²
 E_{tot} = total electric field strength in V/m

3.4 SAM Phantom

The SAM Phantom is constructed of a fiberglass shell integrated in a wooden table. The shape of the shell is based on data from an anatomical study designed to determine the maximum exposure in at least 90 % of all users. It enables the dosimetric evaluation of left and right hand phone usage as well as body mounted usage at the flat phantom region. A cover prevents the evaporation of the liquid. Reference markings on the Phantom allow the complete setup of all predefined phantom positions and measurement grids by manually teaching three points in the robot.

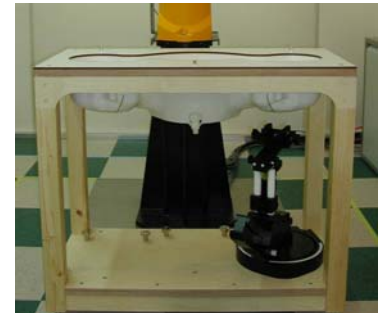

Figure 3.6 SAM Phantom

Shell Thickness	2.0 mm
Filling Volume	about 30 L
Dimensions	810 mm x 1 000 mm x 500 mm (H x L x W)

3.5 Device Holder for Transmitters

In combination with the SAM Phantom V 4.0, the Mounting Device (POM) enables the rotation of the mounted transmitter in spherical coordinates whereby the rotation points is the ear opening. The devices can be easily, accurately, and repeatably positioned according to the FCC and CENELEC specifications. The device holder can be locked at different phantom locations (left head, right head, flat phantom).

Note: A simulating human hand is not used due to the complex anatomical and geometrical structure of the hand that may produced infinite number of configurations. To produce the Worst-case condition (the hand absorbs antenna output power), the hand is omitted during the tests.



Figure 3.7 Device Holder

3.6 Brain & Muscle Simulating Mixture Characterization

The brain and muscle mixtures consist of a viscous gel using hydrox-ethyl cellulose (HEC) gelling agent and saline solution (see Table 3.1). Preservation with a bactericide is added and visual inspection is made to make sure air bubbles are not trapped during the mixing process. The mixture is calibrated to obtain proper dielectric constant (permittivity) and conductivity of the desired tissue. The mixture characterizations used for the brain and muscle tissue simulating liquids are according to the data by C. Gabriel and G. Hartsgrove.

Ingredients (% by weight)	Frequency (MHz)									
	450		835		915		1 900		2 450	
Tissue Type	Head	Body	Head	Body	Head	Body	Head	Body	Head	Body
Water	38.56	51.16	41.45	52.4	41.05	56.0	54.9	40.4	62.7	73.2
Salt (NaCl)	3.95	1.49	1.45	1.4	1.35	0.76	0.18	0.5	0.5	0.04
Sugar	56.32	46.78	56.0	45.0	56.5	41.76	0.0	58.0	0.0	0.0
HEC	0.98	0.52	1.0	1.0	1.0	1.21	0.0	1.0	0.0	0.0
Bactericide	0.19	0.05	0.1	0.1	0.1	0.27	0.0	0.1	0.0	0.0
Triton X-100	0.0	0.0	0.0	0.0	0.0	0.0	0.0	0.0	36.8	0.0
DGBE	0.0	0.0	0.0	0.0	0.0	0.0	44.92	0.0	0.0	26.7

Salt:	99 % Pure Sodium Chloride	Sugar:	98 % Pure Sucrose
Water:	De-ionized, 16M resistivity	HEC:	Hydroxyethyl Cellulose
DGBE:	99 % Di(ethylene glycol) butyl ether,[2-(2-butoxyethoxy) ethanol]		
Triton X-100(ultra pure):	Polyethylene glycol mono[4-(1,1,3,3-tetramethylbutyl)phenyl] ether		

Table 3.1 Composition of the Tissue Equivalent Matter

3.7 SAR TEST EQUIPMENT

Manufacturer	Type / Model	S/N	Calib. Date	Calib.Interval	Calib.Due
SPEAG	SAM Phantom	-	N/A	N/A	N/A
Staubli	Robot RX90L	F01/5K09A1/A/01	N/A	N/A	N/A
Staubli	Robot ControllerCS7MB	F99/5A82A1/C/01	N/A	N/A	N/A
HP	Pavilion t000_puffer	KRJ51201TV	N/A	N/A	N/A
SPEAG	Light Alignment Sensor	265	N/A	N/A	N/A
Staubli	Teach Pendant (Joystick)	D221340.01	N/A	N/A	N/A
SPEAG	DAE4	869	Sept. 03, 2008	Annual	Sept. 03, 2009
SPEAG	DAE3	446	May 22, 2009	Annual	May 22, 2010
SPEAG	E-Field Probe ET3DV6	1630	Aug. 25, 2008	Annual	Aug. 25, 2009
SPEAG	E-Field Probe ET3DV6	1609	Mar. 17, 2009	Annual	Mar. 17, 2010
SPEAG	Validation Dipole D450V2	1007	July 15, 2008	Biennial	July 15, 2010
SPEAG	Validation Dipole D835V2	441	May 25, 2009	Annual	May 25, 2010
SPEAG	Validation Dipole D900V2	130	Aug. 25, 2008	Annual	Aug. 25, 2009
SPEAG	Validation Dipole D1800V2	2d007	May 20, 2008	Biennial	May 20, 2010
SPEAG	Validation Dipole D1900V2	5d032	July 22, 2008	Annual	July 22, 2009
SPEAG	Validation Dipole D2450V2	743	Aug. 27, 2008	Biennial	Aug. 27, 2010
Agilent	Power Meter(F) E4419B	MY41291386	Nov. 05, 2008	Annual	Nov. 05, 2009
Agilent	Power Sensor(G) 8481	MY41090870	Nov. 05, 2008	Annual	Nov. 05, 2009
HP	Dielectric Probe Kit 85070C	00721521	N/A	N/A	N/A
HP	Dual Directional Coupler	16072	Nov. 05, 2008	Annual	Nov. 05, 2009
R&S	Base Station CMU200	110740	July 26, 2008	Annual	July 26, 2009
Agilent	Base Station E5515C	GB44400269	Feb. 10, 2009	Annual	Feb. 10, 2010
HP	Signal Generator E4438C	MY42082646	Dec. 24, 2008	Annual	Dec. 24, 2009
HP	Network Analyzer 8753C	3310J01394	Dec. 04, 2008	Annual	Dec. 04, 2009
Tescom	TC-3000/ Bluetooth	3000A490112	Jan. 09, 2009	Annual	Jan. 09, 2010

NOTE:

The E-field probe was calibrated by SPEAG, by the waveguide technique procedure. Dipole Validation measurement is performed by HCT Lab. before each test. The brain simulating material is calibrated by HCT using the dielectric probe system and network analyzer to determine the conductivity and permittivity (dielectric constant) of the brain-equivalent material.

4. SAR MEASUREMENT PROCEDURE

The evaluation was performed with the following procedure:

1. The SAR value at a fixed location above the ear point was measured and was used as a reference value for assessing the power drop.
2. The SAR distribution at the exposed side of the head was measured at a distance of 3.9 mm from the inner surface of the shell. The area covered the entire dimension of the head and the horizontal grid spacing was 20 mm x 20 mm. Based on this data, the area of the maximum absorption was determined by spline interpolation.
3. Around this point, a volume of 32 mm x 32 mm x 30 mm was assessed by measuring 5 x 5 x 7 points. On this basis of this data set, the spatial peak SAR value was evaluated with the following procedure:
 - a. The data at the surface were extrapolated, since the center of the dipoles is 2.7 mm away from the tip of the probe and the distance between the surface and the lowest measuring point is 1.2 mm. The extrapolation was based on a least square algorithm. A polynomial of the fourth order was calculated through the points in z-axes. This polynomial was then used to evaluate the points between the surface and the probe tip.
 - b. The maximum interpolated value was searched with a straight-forward algorithm. Around this maximum the SAR values averaged over the spatial volumes (1 g or 10 g) were computed using the 3D-Spline interpolation algorithm. The 3D-spline is composed of three one-dimensional splines with the "Not a knot" condition (in x, y, and z directions. The volume was integrated with the trapezoidal algorithm. One thousand points (10 x 10 x 10) were interpolated to calculate the average.
 - c. All neighboring volumes were evaluated until no neighboring volume with a higher average value was found.
4. The SAR value, at the same location as procedure #1, was re-measured. If the value changed by more than 5 %, the evaluation is repeated.

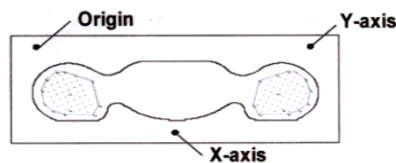

Figure 4.1 SAR Measurement Point in Area Scan

5. DESCRIPTION OF TEST POSITION

5.1 HEAD POSITION

The device was placed in a normal operating position with the Point A on the device, as illustrated in following drawing, aligned with the location of the RE(ERP) on the phantom. With the ear-piece pressed against the head, the vertical center line of the body of the handset was aligned with an imaginary plane consisting of the RE, LE and M. While maintaining these alignments, the body of the handset was gradually moved towards the cheek until any point on the mouth-piece or keypad contacted the cheek. This is a cheek/touch position. For ear/tilt position, while maintain the device aligned with the BM and FN lines, the device was pivot against ERP back for 15° or until the device antenna touch the phantom. Please refer to IEEE 1528-2003 illustration below.

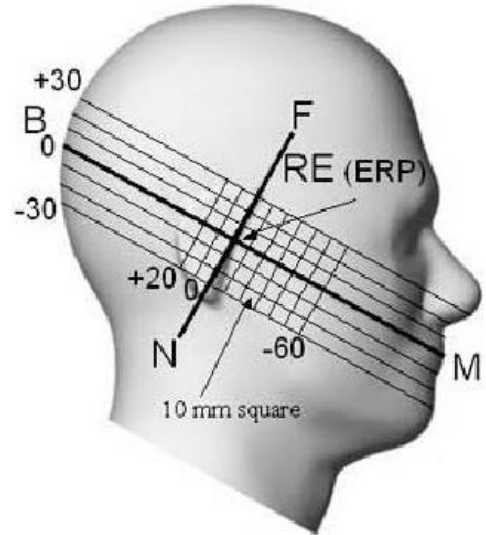

Figure 5.1 Side view of the phantom

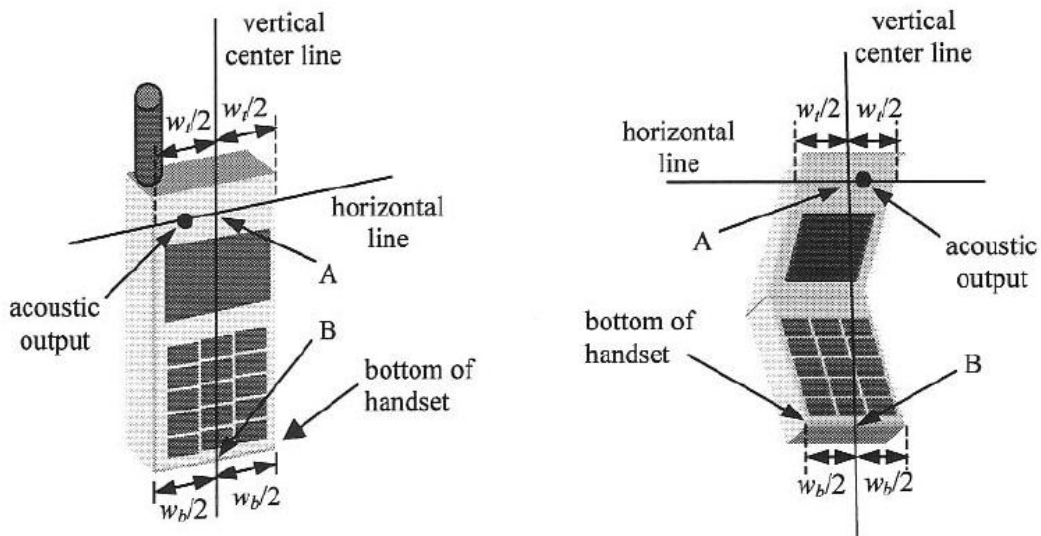

Figure 5.2 Handset vertical and horizontal reference lines

5.2 Body Holster/Belt Clip Configurations

Body-worn operating configurations are tested with the belt-clips and holsters attached to the device and positioned against a flat phantom in a normal use configuration. A device with a headset output is tested with a headset connected to the device. Body dielectric parameters are used.

Accessories for Body-worn operation configurations are divided into two categories: those that do not contain metallic components and those that contain metallic components. When multiple accessories that do not contain metallic components are supplied with the device, the device is tested with only the accessory that dictates the closest spacing to the body. Then multiple accessories that contain metallic components are tested with each accessory. If multiple accessory share an identical metallic component (i.e. the same metallic belt-clip used with different holsters with no other metallic components) only the accessory that dictates the closest spacing to the body is tested.

Body-worn accessories may not always be supplied or available as options for some Devices intended to be authorized for body-worn use. In this case, a test configuration with a separation distance between the back of the device and the flat phantom is used.

Since this EUT does not supply any body worn accessory to the end user a distance of 1.5 cm from the EUT back surface to the liquid interface is configured for the generic test.

"See the Test SET-UP Photo"

Transmitters that are designed to operate in front of a person's face, as in push-to-talk configurations, are tested for SAR compliance with the front of the device positioned to face the flat phantom. For devices that are carried next to the body such as a shoulder, waist or chest-worn transmitters, SAR compliance is tested with the accessory(ies), including headsets and microphones, attached to the device and positioned against a flat phantom in a normal use configuration.

In all cases SAR measurements are performed to investigate the worst-case positioning. Worstcase positioning is then documented and used to perform Body SAR testing.

6. MEASUREMENT UNCERTAINTY

Measurement uncertainties in SAR measurements are difficult to quantify due to several variables including biological, physiological, and environmental. However, we estimate the measurement uncertainties in SAR to be less than 15 % - 25 %.

According to ANSI/IEEE C95.3, the overall uncertainties are difficult to assess and will vary with the type of meter and usage situation. However, accuracy's of 1 dB to ± 3 dB can be expected in practice, with greater uncertainties in near-field situations and at higher frequencies (shorter wavelengths), or areas where large reflecting objects are present. Under optimum measurement conditions, SAR measurement uncertainties of at least ± 2 dB can be expected.

According to CENELEC, typical worst-case uncertainty of field measurements is 5 dB. For well-defined modulation characteristics the uncertainty can be reduced to ± 3 dB.

Error Description	Uncertainty value [%]	Probability Distribution	Divisor	ci	ci ²	Standard Uncertainty [%]	Stand Uncert ²	(Stand Uncert ²) X (ci ²)	Vi & Veff
1. Measurement System									
Probe Calibration	5.5	Normal	1.00	1	1	5.50	30.25	30.25	∞
Axial Isotropy	4.7	Rectangular	1.73	0.7	0.49	2.71	7.36	3.61	∞
Hemispherical Isotropy	9.6	Rectangular	1.73	0.7	0.49	5.54	30.72	15.05	∞
Linearity	4.7	Rectangular	1.73	1	1	2.71	7.36	7.36	∞
System Detection limits	1.0	Rectangular	1.73	1	1	0.58	0.33	0.33	∞
Boundary effect	1.0	Rectangular	1.73	1	1	0.58	0.33	0.33	∞
Response time	0.8	Rectangular	1.73	1	1	0.46	0.21	0.21	∞
RF Ambient conditions	3.0	Rectangular	1.73	1	1	1.73	3.00	3.00	∞
Readout Electronics	0.3	Normal	1.00	1	1	0.30	0.09	0.09	∞
Integration time	2.6	Rectangular	1.73	1	1	1.50	2.25	2.25	∞
Probe positioner	0.4	Rectangular	1.73	1	1	0.23	0.05	0.05	∞
Probe positioning	2.9	Rectangular	1.73	1	1	1.67	2.80	2.80	∞
Maximum SAR evaluation	1.0	Rectangular	1.73	1	1	0.58	0.33	0.33	∞
Sub Total								65.69	
2. Test Sample Related									
Device Positioning	1.8	Normal	1.00	1	1	1.81	3.28	3.28	9
Device Holder	3.6	Normal	1.00	1	1	3.60	12.96	12.96	∞
Power Drift	5.0	Rectangular	1.73	1	1	2.89	8.33	8.33	∞
Sub Total								24.57	
3. Phantom and Setup									
Phantom Uncertainty	4.0	Rectangular	1.73	1	1	2.31	5.33	5.33	∞
Liquid conductivity (target)	5.0	Rectangular	1.73	0.5	0.25	2.89	8.33	2.08	∞
Liquid conductivity (measurement error)	2.5	Normal	1.00	0.5	0.25	2.50	6.25	1.56	∞
Liquid permittivity (target)	5.0	Rectangular	1.73	0.5	0.25	2.89	8.33	2.08	∞
Liquid permittivity (measurement error)	2.5	Normal	1.00	0.5	0.25	2.50	6.25	1.56	∞
Sub Total								12.63	
Combined standard SAR uncertainty [%]						10.14		102.88	-
Expanded uncertainty [k=2, approximately confidence level 95 %]						± 20.28 %			

Table 6.1 Breakdown of Errors

7. ANSI/ IEEE C95.1 - 2005 RF EXPOSURE LIMITS

HUMAN EXPOSURE	UNCONTROLLED ENVIRONMENT General Population (W/kg) or (mW/g)	CONTROLLED ENVIRONMENT Occupational (W/kg) or (mW/g)
SPATIAL PEAK SAR * (Brain)	1.60	8.00
SPATIAL AVERAGE SAR ** (Whole Body)	0.08	0.40
SPATIAL PEAK SAR *** (Hands / Feet / Ankle / Wrist)	4.00	20.00

Table 7.1 Safety Limits for Partial Body Exposure

NOTES:

* The Spatial Peak value of the SAR averaged over any 1 g of tissue (defined as a tissue volume in the shape of a cube) and over the appropriate averaging time.

** The Spatial Average value of the SAR averaged over the whole-body.

*** The Spatial Peak value of the SAR averaged over any 10 g of tissue (defined as a tissue volume in the shape of a cube) and over the appropriate averaging time.

Uncontrolled Environments are defined as locations where there is the exposure of individuals who have no knowledge or control of their exposure.

Controlled Environments are defined as locations where there is exposure that may be incurred by persons who are aware of the potential for exposure, (i.e.as a result of employment or occupation).

8. SYSTEM VERIFICATION

8.1 Tissue Verification

Freq. [MHz]	Date	Liquid	Liquid Temp.[°C]	Parameters	Target Value	Measured Value	Deviation [%]	Limit [%]
835	Jul.12, 2009	Head	21.2	ϵr	41.5	40.7	- 1.93	± 5
				σ	0.90	0.872	- 3.11	± 5
835	Jul.12, 2009	Body	21.2	ϵr	55.2	53.9	- 2.36	± 5
				σ	0.97	0.99	+ 2.06	± 5
1 900	Jul.13, 2009	Head	21.2	ϵr	40.0	38.9	- 2.75	± 5
				σ	1.40	1.41	+ 0.71	± 5
1 900	Jul.13, 2009	Body	21.2	ϵr	53.3	52.3	- 1.88	± 5
				σ	1.52	1.51	- 0.66	± 5

8.2 System Validation

Prior to assessment, the system is verified to the $\pm 10\%$ of the specifications at 835 MHz/ 1 900 MHz by using the system validation kit. (Graphic Plots Attached)

*Input Power: 100 mW

Freq. [MHz]	Date	Liquid	Liquid Temp. [°C]	SAR Average	Target Value (SPEAG) (mW/g)	Measured Value (mW/g)	Deviation [%]	Limit [%]
835	Jul.12, 2009	Head	21.2	1 g	9.56	0.983	+ 2.82	± 10
1 900	Jul.13, 2009	Head	21.2	1 g	37.7	3.8	+ 0.80	± 10

9. RF CONDUCTED POWER

Power measurements were performed using a base station simulator under digital average power

9.1 Procedures Used to Establish RF Signal for SAR

The handset was placed into a simulated call using a base station simulator in a shielded chamber. Such test signals offer a consistent means for testing SAR and are recommended for evaluation SAR[4] SAR measurements were taken with a fully charged battery. In order to verify that the device was tested and maintained at full power, this was configured with the base station simulator. The SAR measurement Software calculates a reference point at the start and end of the test to check for power drifts. If conducted Power deviations of more then 5 % occurred, the tests were repeated.

Average Output Power Measurement for FCC ID: WVBS100

Band	Channel	Voice	GPRS Data			
		GSM (dBm)	GPRS 1 TX Slot (dBm)	GPRS 2 TX Slot (dBm)	GPRS 3 TX Slot (dBm)	GPRS 4 TX Slot (dBm)
GSM 850	128	31.86	31.80	30.78	29.57	28.22
	190	31.80	31.74	30.72	29.52	28.15
	251	31.81	31.75	30.75	29.56	28.23
GSM 1900	512	28.98	28.90	28.41	27.62	26.65
	661	28.89	28.81	28.32	27.54	26.57
	810	28.80	28.73	28.24	27.43	26.50

Table 9.1 GSM Conducted output powers

10. SAR TEST DATA SUMMARY

10.1 Measurement Results (GSM850 Head SAR Touch)

Frequency		Modulation	Conducted Power (dBm)		Battery	Phantom Position	Antenna Type	SAR(mW/g)
MHz	Channel		Begin	End				
836.6	190 (Mid)	GSM850	31.80	31.74	Standard	Left Ear	Intenna	0.798
824.2	128 (Low)	GSM850	31.86	31.71	Standard	Right Ear	Intenna	0.741
836.6	190 (Mid)	GSM850	31.80	31.71	Standard	Right Ear	Intenna	0.855
848.8	251 (High)	GSM850	31.81	31.73	Standard	Right Ear	Intenna	0.993
ANSI/ IEEE C95.1 2005 – Safety Limit Spatial Peak Uncontrolled Exposure/ General Population						Head 1.6 W/kg (mW/g) <small>Averaged over 1 gram</small>		

NOTES:

- The test data reported are the worst-case SAR value with the antenna-head position set in a typical configuration. Test procedures used are according to FCC/OET Bulletin 65, Supplement C [July 2001].
- All modes of operation were investigated and the worst-case are reported.
- Measured Depth of Simulating Tissue is 15.0 cm ± 0.2 cm.
- Tissue parameters and temperatures are listed on the SAR plot.
- Battery Type Standard Extended Slim
Batteries are fully charged for all readings.
- Test Signal Call Mode Manual Test cord Base Station Simulator

10.2 Measurement Results (GSM850 Head SAR Tilt)

Frequency		Modulation	Conducted Power (dBm)		Battery	Phantom Position	Antenna Type	SAR(mW/g)
MHz	Channel		Begin	End				
836.6	190 (Mid)	GSM850	31.80	31.98	Standard	Left Tilt 15°	Intenna	0.355
836.6	190 (Mid)	GSM850	31.80	31.67	Standard	Right Tilt 15°	Intenna	0.384
ANSI/ IEEE C95.1 2005 – Safety Limit						Head		
Spatial Peak						1.6 W/kg (mW/g)		
Uncontrolled Exposure/ General Population						<small>Averaged over 1 gram</small>		

NOTES:

- 1 The test data reported are the worst-case SAR value with the antenna-head position set in a typical configuration. Test procedures used are according to FCC/OET Bulletin 65, Supplement C [July 2001].
- 2 All modes of operation were investigated and the worst-case are reported.
- 3 Measured Depth of Simulating Tissue is 15.0 cm ± 0.2 cm.
- 4 Tissue parameters and temperatures are listed on the SAR plot.
- 5 Battery Type Standard Extended Slim
Batteries are fully charged for all readings.
- 6 Test Signal Call Mode Manual Test cord Base Station Simulator
- 7 Justification for reduced test configurations: per FCC/OET Supplement C (July, 2001), if the SAR measured at the middle channel for each test configuration (Left, right, cheek/touch, tilt/ear, extended and retracted) is at least 3.0 dB lower than the SAR limit, testing at the high and low channels is optional for such test configuration(s).

10.3 Measurement Results (GSM1900 Head SAR Touch)

Frequency		Modulation	Conducted Power (dBm)		Battery	Phantom Position	Antenna Type	SAR(mW/g)
MHz	Channel		Begin	End				
1 880.0	661 (Mid)	GSM1900	28.89	28.81	Standard	Left Ear	Intenna	0.664
1 880.0	661 (Mid)	GSM1900	28.89	28.80	Standard	Right Ear	Intenna	0.466
ANSI/ IEEE C95.1 2005 – Safety Limit						Head		
Spatial Peak						1.6 W/kg (mW/g)		
Uncontrolled Exposure/ General Population						Averaged over 1 gram		

NOTES:

- 1 The test data reported are the worst-case SAR value with the antenna-head position set in a typical configuration. Test procedures used are according to FCC/OET Bulletin 65, Supplement C [July 2001].
- 2 All modes of operation were investigated and the worst-case are reported.
- 3 Measured Depth of Simulating Tissue is 15.0 cm ± 0.2 cm.
- 4 Tissue parameters and temperatures are listed on the SAR plot.
- 5 Battery Type Standard Extended Slim
Batteries are fully charged for all readings.
- 6 Test Signal Call Mode Manual Test cord Base Station Simulator
- 7 Justification for reduced test configurations: per FCC/OET Supplement C (July, 2001), if the SAR measured at the middle channel for each test configuration (Left, right, cheek/touch, tilt/ear, extended and retracted) is at least 3.0 dB lower than the SAR limit, testing at the high and low channels is optional for such test configuration(s).

10.4 Measurement Results (GSM1900 Head SAR Tilt)

Frequency		Modulation	Conducted Power (dBm)		Battery	Phantom Position	Antenna Type	SAR(mW/g)
MHz	Channel		Begin	End				
1 880.0	661 (Mid)	GSM1900	28.89	28.75	Standard	Left Tilt 15°	Intenna	0.259
1 880.0	661 (Mid)	GSM1900	28.89	28.73	Standard	Right Tilt 15°	Intenna	0.209
ANSI/ IEEE C95.1 2005 – Safety Limit						Head		
Spatial Peak						1.6 W/kg (mW/g)		
Uncontrolled Exposure/ General Population						Averaged over 1 gram		

NOTES:

- 1 The test data reported are the worst-case SAR value with the antenna-head position set in a typical configuration. Test procedures used are according to FCC/OET Bulletin 65, Supplement C [July 2001].
- 2 All modes of operation were investigated and the worst-case are reported.
- 3 Measured Depth of Simulating Tissue is 15.0 cm ± 0.2 cm.
- 4 Tissue parameters and temperatures are listed on the SAR plot.
- 5 Battery Type Standard Extended Slim
Batteries are fully charged for all readings.
- 6 Test Signal Call Mode Manual Test cord Base Station Simulator
- 7 Justification for reduced test configurations: per FCC/OET Supplement C (July, 2001), if the SAR measured at the middle channel for each test configuration (Left, right, cheek/touch, tilt/ear, extended and retracted) is at least 3.0 dB lower than the SAR limit, testing at the high and low channels is optional for such test configuration(s).

10.5 Measurement Results (GSM850 Body SAR)

Frequency		Modulation	Conducted Power (dBm)		Configuration	Phantom Position	Antenna Type	SAR(mW/g)
MHz	Channel		Begin	End				
836.6	190 (Mid)	GPRS 1Tx	31.74	31.72	Rear	1.5 cm without Holster	Intenna	0.573
836.6	190 (Mid)	GPRS 2Tx	30.72	30.66	Rear	1.5 cm without Holster	Intenna	0.883
836.6	190 (Mid)	GPRS 3Tx	29.52	29.5	Rear	1.5 cm without Holster	Intenna	1.05
836.6	190 (Mid)	GPRS 4Tx	28.15	28.14	Rear	1.5 cm without Holster	Intenna	1.20
824.2	128 (Low)	GPRS 4Tx	28.22	28.02	Rear	1.5 cm without Holster	Intenna	1.00
848.8	251 (High)	GPRS 4Tx	28.23	28.21	Rear	1.5 cm without Holster	Intenna	1.36
848.8	251 (High)	GPRS 4Tx	28.23	28.09	Front	1.5 cm without Holster	Intenna	1.33
848.8	251 (High)	GSM850	31.81	31.79	Rear	1.5 cm without Holster	Intenna	0.646
ANSI/ IEEE C95.1 2005 – Safety Limit						Body		
Spatial Peak						1.6 W/kg (mW/g)		
Uncontrolled Exposure/ General Population						<small>Averaged over 1 gram</small>		

NOTES:

- 1 The test data reported are the worst-case SAR value with the antenna-head position set in a typical configuration. Test procedures used are according to FCC/OET Bulletin 65, Supplement C [July 2001].
- 2 All modes of operation were investigated and the worst-case are reported.
- 3 Measured Depth of Simulating Tissue is 15.0 cm ± 0.2 cm.
- 4 Tissue parameters and temperatures are listed on the SAR plot.
- 5 Battery Type Standard Extended Slim
Batteries are fully charged for all readings.
- 6 Test Signal Call Mode Manual Test cord Base Station Simulator

10.6 Measurement Results (GSM1900 Body SAR)

Frequency		Modulation	Conducted Power (dBm)		Configuration	Phantom Position	Antenna Type	SAR(mW/g)
MHz	Channel		Begin	End				
1 880.0	661 (Mid)	GPRS 1Tx	28.81	28.87	Rear	1.5 cm without Holster	Intenna	0.198
1 880.0	661 (Mid)	GPRS 2Tx	28.32	28.33	Rear	1.5 cm without Holster	Intenna	0.387
1 880.0	661 (Mid)	GPRS 3Tx	27.54	27.53	Rear	1.5 cm without Holster	Intenna	0.572
1 880.0	661 (Mid)	GPRS 4Tx	26.57	26.41	Rear	1.5 cm without Holster	Intenna	0.765
1 880.0	661 (Mid)	GPRS 4Tx	26.57	26.48	Front	1.5 cm without Holster	Intenna	0.342
1 880.0	661 (Mid)	GSM1900	28.89	28.92	Rear	1.5 cm without Holster	Intenna	0.207
ANSI/ IEEE C95.1 2005 – Safety Limit						Body		
Spatial Peak						1.6 W/kg (mW/g)		
Uncontrolled Exposure/ General Population						<small>Averaged over 1 gram</small>		

NOTES:

- 1 The test data reported are the worst-case SAR value with the antenna-head position set in a typical configuration. Test procedures used are according to FCC/OET Bulletin 65, Supplement C [July 2001].
- 2 All modes of operation were investigated and the worst-case are reported.
- 3 Measured Depth of Simulating Tissue is 15.0 cm ± 0.2 cm.
- 4 Tissue parameters and temperatures are listed on the SAR plot.
- 5 Battery Type Standard Extended Slim
Batteries are fully charged for all readings.
- 6 Test Signal Call Mode Manual Test cord Base Station Simulator
- 7 Both side of the phone were tested and the worst-case side is reported.
- 8 HEADSET was connected.
- 9 Test Configuration With Holster Without Holster
- 10 Justification for reduced test configurations: per FCC/OET Supplement C (July, 2001), if the SAR measured at the middle channel for each test configuration (Left, right, cheek/touch, tilt/ear, extended and retracted) is at least 3.0 dB lower than the SAR limit, testing at the high and low channels is optional for such test configuration(s).

11. CONCLUSION

The SAR measurement indicates that the EUT complies with the RF radiation exposure limits of the ANSI/IEEE C95.1 2005.

These measurements are taken to simulate the RF effects exposure under worst-case conditions. Precise laboratory measures were taken to assure repeatability of the tests.

12. REFERENCES

- [1] Federal Communications Commission, OET Bulletin 65 (Edition 97-01), Supplement C (Edition 01-01), Evaluating Compliance with FCC Guidelines for Human Exposure to Radio frequency Electromagnetic Fields, July 2001.
- [2] IEEE Standards Coordinating Committee 34 – IEEE Std. 1528-2003, IEEE Recommended Practice for Determining the Peak Spatial-Average Specific Absorption Rate (SAR) in the Human Body from Wireless Communications Devices.
- [3] Federal Communications Commission, ET Docket 93-62, Guidelines for Evaluating the Environmental Effects of Radio frequency Radiation, Aug. 1996.
- [4] ANSI/IEEE C95.1 - 1991, American National Standard safety levels with respect to human exposure to radio frequency electromagnetic fields, 300 kHz to 100 GHz, New York: IEEE, Aug. 1992
- [5] ANSI/IEEE C95.3 - 1991, IEEE Recommended Practice for the Measurement of Potentially Hazardous Electromagnetic Fields - RF and Microwave, New York: IEEE, 1992.
- [6] NCRP, National Council on Radiation Protection and Measurements, Biological Effects and Exposure Criteria for Radio Frequency Electromagnetic Fields, NCRP Report No. 86, 1986. Reprinted Feb. 1995.
- [7] T. Schmid, O. Egger, N. Kuster, Automated E-field scanning system for dosimetric assessments, IEEE Transaction on Microwave Theory and Techniques, vol. 44, Jan. 1996, pp. 105-113.
- [8] K. Pokovic, T. Schmid, N. Kuster, Robust setup for precise calibration of E-field probes in tissue simulating liquids at mobile communications frequencies, ICECOM97, Oct. 1997, pp. 120-124.
- [9] K. Pokovic, T. Schmid, and N. Kuster, E-field Probe with improved isotropy in brain simulating liquids, Proceedings of the ELMAR, Zadar, Croatia, June 23-25, 1996, pp. 172-175.
- [10] Schmid & Partner Engineering AG, Application Note: Data Storage and Evaluation, June 1998, p2.
- [11] V. Hombach, K. Meier, M. Burkhardt, E. Kuhn, N. Kuster, The Dependence of EM Energy Absorption upon Human Head Modeling at 900 MHz, IEEE Transaction on Microwave Theory and Techniques, vol. 44 no. 10, Oct. 1996, pp. 1865-1873.
- [12] N. Kuster and Q. Balzano, Energy absorption mechanism by biological bodies in the near field of dipole antennas above 300 MHz, IEEE Transaction on Vehicular Technology, vol. 41, no. 1, Feb. 1992, pp. 17-23.
- [13] G. Hartsgrove, A. Kraszewski, A. Surowiec, Simulated Biological Materials for Electromagnetic Radiation Absorption Studies, University of Ottawa, Bioelectromagnetics, Canada: 1987, pp. 29-36.
- [14] Q. Balzano, O. Garay, T. Manning Jr., Electromagnetic Energy Exposure of Simulated Users of Portable Cellular Telephones, IEEE Transactions on Vehicular Technology, vol. 44, no.3, Aug. 1995.
- [15] W. Gander, Computer mathematic, Birkhaeuser, Basel, 1992.
- [16] W.H. Press, S.A. Teukolsky, W.T. Vetterling, and B.P. Flannery, Numerical Recipes in C, The Art of Scientific Computing, Second edition, Cambridge University Press, 1992.
- [17] Federal Communications Commission, OET Bulletin 65, Evaluating Compliance with FCC Guidelines for Human Exposure to Radiofrequency Electromagnetic Fields. Supplement C, Dec. 1997.
- [18] N. Kuster, R. Kastle, T. Schmid, Dosimetric evaluation of mobile communications equipment with known precision, IEEE Transaction on Communications, vol. E80-B, no. 5, May 1997, pp. 645-652.
- [19] CENELEC CLC/SC111B, European Prestandard (prENV 50166-2), Human Exposure to Electromagnetic Fields High-frequency: 10 kHz-300 GHz, Jan. 1995.
- [20] Prof. Dr. Niels Kuster, ETH, Eidgenössische Technische Hochschule Zürich, Dosimetric Evaluation of the Cellular Phone.

Attachment 1. – SAR Test Plots

Test Laboratory: HCT CO., LTD
EUT Type: Cellular/PCS GSM Phone(850/1800/1900)
Liquid Temperature: 21.2 °C
Ambient Temperature: 21.4 °C
Test Date: Jul.12, 2009

DUT: QS100; Type: Bar; Serial: #1

Communication System: GSM 850; Frequency: 836.6 MHz; Duty Cycle: 1:8.3
Medium parameters used (interpolated): $f = 836.6$ MHz; $\sigma = 0.874$ mho/m; $\epsilon_r = 40.6$; $\rho = 1000$ kg/m³
Phantom section: Left Section ; Measurement SW: DASY4, V4.7 Build 80; Postprocessing SW: SEMCAD, V1.8 Build 176

DASY4 Configuration:

- Probe: ET3DV6 - SN1609; ConvF(6.25, 6.25, 6.25); Calibrated: 2009-03-17
- Sensor-Surface: 4mm (Mechanical Surface Detection)
- Electronics: DAE4 Sn869; Calibrated: 2008-09-03
- Phantom: 835/900 Phantom ; Type: SAM

Left touch 190/Area Scan (51x91x1): Measurement grid: dx=15mm, dy=15mm

[Info: Interpolated medium parameters used for SAR evaluation.](#)

Maximum value of SAR (interpolated) = 0.856 mW/g

Left touch 190/Zoom Scan (5x5x7)/Cube 0: Measurement grid: dx=8mm, dy=8mm, dz=5mm

Reference Value = 8.95 V/m; Power Drift = -0.059 dB

Peak SAR (extrapolated) = 1.06 W/kg

SAR(1 g) = 0.798 mW/g; SAR(10 g) = 0.585 mW/g

[Info: Interpolated medium parameters used for SAR evaluation.](#)

Maximum value of SAR (measured) = 0.829 mW/g

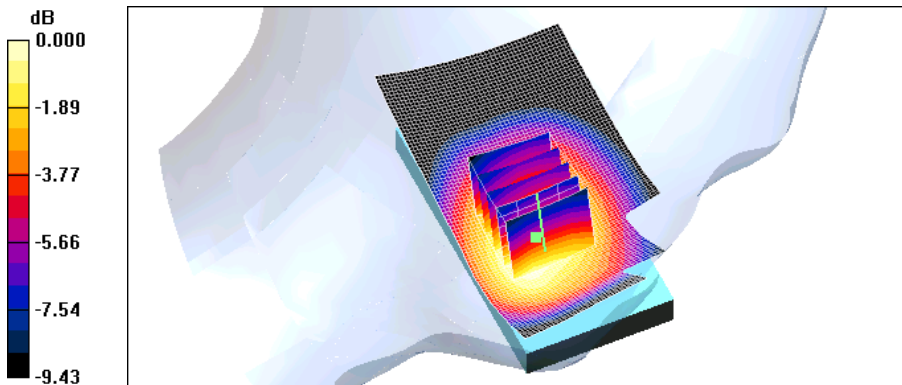

Test Laboratory: HCT CO., LTD
EUT Type: Cellular/PCS GSM Phone(850/1800/1900)
Liquid Temperature: 21.2 °C
Ambient Temperature: 21.4 °C
Test Date: Jul.12, 2009

DUT: QS100; Type: Bar; Serial: #1

Communication System: GSM 850; Frequency: 824.2 MHz; Duty Cycle: 1:8.3
Medium parameters used: $f = 825$ MHz; $\sigma = 0.861$ mho/m; $\epsilon_r = 40.8$; $\rho = 1000$ kg/m³
Phantom section: Right Section ; Measurement SW: DASY4, V4.7 Build 80; Postprocessing SW: SEMCAD, V1.8 Build 176

DASY4 Configuration:

- Probe: ET3DV6 - SN1609; ConvF(6.25, 6.25, 6.25); Calibrated: 2009-03-17
- Sensor-Surface: 4mm (Mechanical Surface Detection)
- Electronics: DAE4 Sn869; Calibrated: 2008-09-03
- Phantom: 835/900 Phantom ; Type: SAM

Right touch 128/Area Scan (51x91x1): Measurement grid: dx=15mm, dy=15mm
Maximum value of SAR (interpolated) = 0.776 mW/g

Right touch 128/Zoom Scan (5x5x7)/Cube 0: Measurement grid: dx=8mm, dy=8mm, dz=5mm
Reference Value = 8.27 V/m; Power Drift = -0.149 dB
Peak SAR (extrapolated) = 0.917 W/kg
SAR(1 g) = 0.741 mW/g; SAR(10 g) = 0.552 mW/g
Maximum value of SAR (measured) = 0.793 mW/g

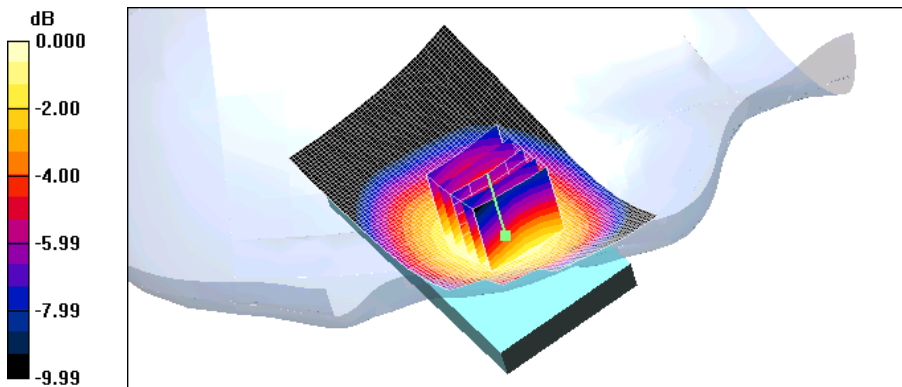

Test Laboratory: HCT CO., LTD
EUT Type: Cellular/PCS GSM Phone(850/1800/1900)
Liquid Temperature: 21.2 °C
Ambient Temperature: 21.4 °C
Test Date: Jul.12, 2009

DUT: QS100; Type: Bar; Serial: #1

Communication System: GSM 850; Frequency: 836.6 MHz; Duty Cycle: 1:8.3
Medium parameters used (interpolated): $f = 836.6$ MHz; $\sigma = 0.874$ mho/m; $\epsilon_r = 40.6$; $\rho = 1000$ kg/m³
Phantom section: Right Section ; Measurement SW: DASY4, V4.7 Build 80; Postprocessing SW: SEMCAD, V1.8 Build 176

DASY4 Configuration:

- Probe: ET3DV6 - SN1609; ConvF(6.25, 6.25, 6.25); Calibrated: 2009-03-17
- Sensor-Surface: 4mm (Mechanical Surface Detection)
- Electronics: DAE4 Sn869; Calibrated: 2008-09-03
- Phantom: 835/900 Phantom ; Type: SAM

Right touch 190/Area Scan (51x91x1): Measurement grid: dx=15mm, dy=15mm

[Info: Interpolated medium parameters used for SAR evaluation.](#)

Maximum value of SAR (interpolated) = 0.884 mW/g

Right touch 190/Zoom Scan (5x5x7)/Cube 0: Measurement grid: dx=8mm, dy=8mm, dz=5mm

Reference Value = 8.93 V/m; Power Drift = -0.090 dB

Peak SAR (extrapolated) = 1.07 W/kg

SAR(1 g) = 0.855 mW/g; SAR(10 g) = 0.634 mW/g

[Info: Interpolated medium parameters used for SAR evaluation.](#)

Maximum value of SAR (measured) = 0.906 mW/g

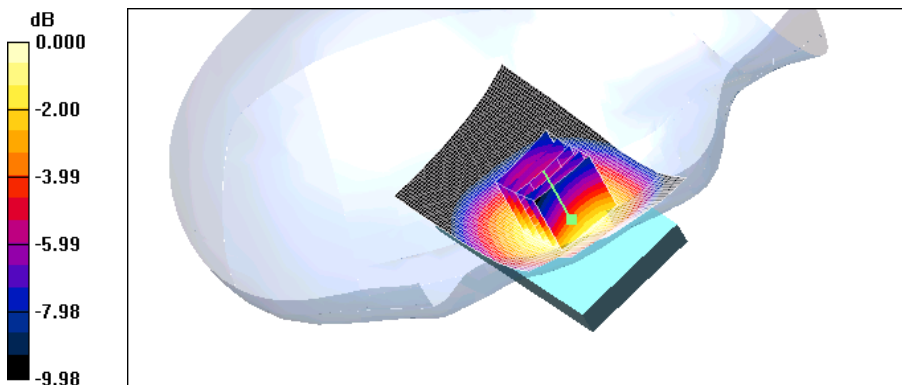

0 dB = 0.906mW/g

Test Laboratory: HCT CO., LTD
EUT Type: Cellular/PCS GSM Phone(850/1800/1900)
Liquid Temperature: 21.2 °C
Ambient Temperature: 21.4 °C
Test Date: Jul.12, 2009

DUT: QS100; Type: Bar; Serial: #1

Communication System: GSM 850; Frequency: 848.8 MHz; Duty Cycle: 1:8.3
Medium parameters used (interpolated): $f = 848.8$ MHz; $\sigma = 0.885$ mho/m; $\epsilon_r = 40.5$; $\rho = 1000$ kg/m³
Phantom section: Right Section ; Measurement SW: DASY4, V4.7 Build 80; Postprocessing SW: SEMCAD, V1.8 Build 176

DASY4 Configuration:

- Probe: ET3DV6 - SN1609; ConvF(6.25, 6.25, 6.25); Calibrated: 2009-03-17
- Sensor-Surface: 4mm (Mechanical Surface Detection)
- Electronics: DAE4 Sn869; Calibrated: 2008-09-03
- Phantom: 835/900 Phantom ; Type: SAM

Right touch 251/Area Scan (51x91x1): Measurement grid: dx=15mm, dy=15mm

[Info: Interpolated medium parameters used for SAR evaluation.](#)

Maximum value of SAR (interpolated) = 1.04 mW/g

Right touch 251/Zoom Scan (5x5x7)/Cube 0: Measurement grid: dx=8mm, dy=8mm, dz=5mm

Reference Value = 9.07 V/m; Power Drift = -0.082 dB

Peak SAR (extrapolated) = 1.24 W/kg

SAR(1 g) = 0.993 mW/g; SAR(10 g) = 0.738 mW/g

[Info: Interpolated medium parameters used for SAR evaluation.](#)

Maximum value of SAR (measured) = 1.06 mW/g

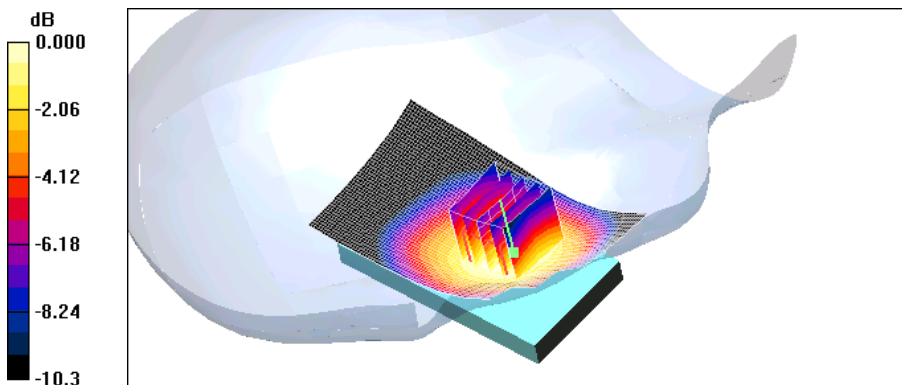

Test Laboratory: HCT CO., LTD
EUT Type: Cellular/PCS GSM Phone(850/1800/1900)
Liquid Temperature: 21.2 °C
Ambient Temperature: 21.4 °C
Test Date: Jul.12, 2009

DUT: QS100; Type: Bar; Serial: #1

Communication System: GSM 850; Frequency: 836.6 MHz; Duty Cycle: 1:8.3
Medium parameters used (interpolated): $f = 836.6$ MHz; $\sigma = 0.874$ mho/m; $\epsilon_r = 40.6$; $\rho = 1000$ kg/m³
Phantom section: Left Section ; Measurement SW: DASY4, V4.7 Build 80; Postprocessing SW: SEMCAD, V1.8 Build 176

DASY4 Configuration:

- Probe: ET3DV6 - SN1609; ConvF(6.25, 6.25, 6.25); Calibrated: 2009-03-17
- Sensor-Surface: 4mm (Mechanical Surface Detection)
- Electronics: DAE4 Sn869; Calibrated: 2008-09-03
- Phantom: 835/900 Phantom ; Type: SAM

Left tilt 190/Area Scan (51x91x1): Measurement grid: dx=15mm, dy=15mm

[Info: Interpolated medium parameters used for SAR evaluation.](#)

Maximum value of SAR (interpolated) = 0.380 mW/g

Left tilt 190/Zoom Scan (5x5x7)/Cube 0: Measurement grid: dx=8mm, dy=8mm, dz=5mm

Reference Value = 11.8 V/m; Power Drift = 0.18 dB

Peak SAR (extrapolated) = 0.444 W/kg

SAR(1 g) = 0.355 mW/g; SAR(10 g) = 0.267 mW/g

[Info: Interpolated medium parameters used for SAR evaluation.](#)

Maximum value of SAR (measured) = 0.378 mW/g

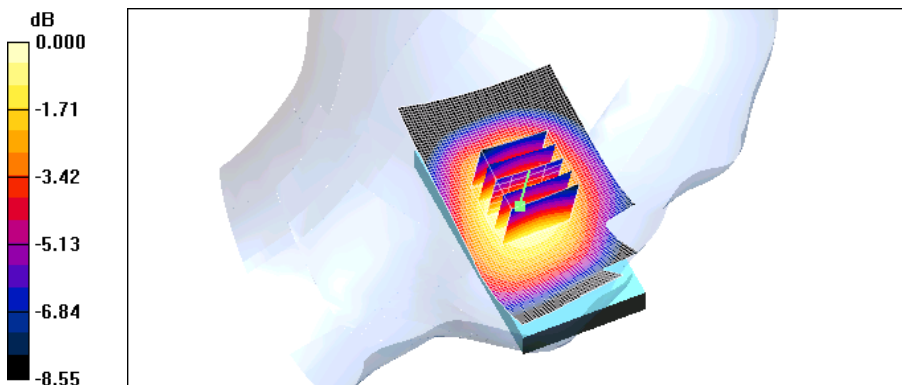

0 dB = 0.378mW/g

Test Laboratory: HCT CO., LTD
EUT Type: Cellular/PCS GSM Phone(850/1800/1900)
Liquid Temperature: 21.2 °C
Ambient Temperature: 21.4 °C
Test Date: Jul.12, 2009

DUT: QS100; Type: Bar; Serial: #1

Communication System: GSM 850; Frequency: 836.6 MHz; Duty Cycle: 1:8.3
Medium parameters used (interpolated): $f = 836.6$ MHz; $\sigma = 0.874$ mho/m; $\epsilon_r = 40.6$; $\rho = 1000$ kg/m³
Phantom section: Right Section ; Measurement SW: DASY4, V4.7 Build 80; Postprocessing SW: SEMCAD, V1.8 Build 176

DASY4 Configuration:

- Probe: ET3DV6 - SN1609; ConvF(6.25, 6.25, 6.25); Calibrated: 2009-03-17
- Sensor-Surface: 4mm (Mechanical Surface Detection)
- Electronics: DAE4 Sn869; Calibrated: 2008-09-03
- Phantom: 835/900 Phantom ; Type: SAM

Right tilt 190/Area Scan (51x91x1): Measurement grid: dx=15mm, dy=15mm

[Info: Interpolated medium parameters used for SAR evaluation.](#)

Maximum value of SAR (interpolated) = 0.404 mW/g

Right tilt 190/Zoom Scan (5x5x7)/Cube 0: Measurement grid: dx=8mm, dy=8mm, dz=5mm

Reference Value = 12.5 V/m; Power Drift = -0.130 dB

Peak SAR (extrapolated) = 0.470 W/kg

SAR(1 g) = 0.384 mW/g; SAR(10 g) = 0.293 mW/g

[Info: Interpolated medium parameters used for SAR evaluation.](#)

Maximum value of SAR (measured) = 0.403 mW/g

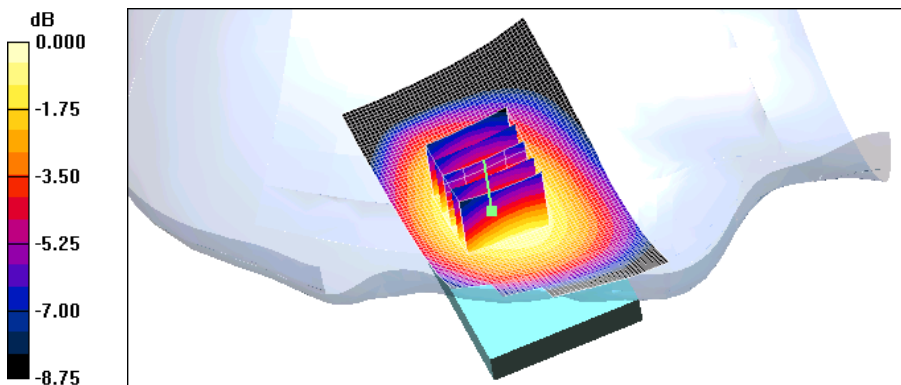

Test Laboratory: HCT CO., LTD
EUT Type: Cellular/PCS GSM Phone(850/1800/1900)
Liquid Temperature: 21.2 °C
Ambient Temperature: 21.4 °C
Test Date: Jul.13, 2009

DUT: QS100; Type: Bar; Serial: #1

Communication System: GSM 1900; Frequency: 1880 MHz; Duty Cycle: 1:8.3
Medium parameters used: $f = 1880$ MHz; $\sigma = 1.38$ mho/m; $\epsilon_r = 39$; $\rho = 1000$ kg/m³
Phantom section: Left Section ; Measurement SW: DASY4, V4.7 Build 80; Postprocessing SW: SEMCAD, V1.8 Build 176

DASY4 Configuration:

- Probe: ET3DV6 - SN1609; ConvF(5.12, 5.12, 5.12); Calibrated: 2009-03-17
- Sensor-Surface: 4mm (Mechanical Surface Detection)
- Electronics: DAE4 Sn869; Calibrated: 2008-09-03
- Phantom: 1800/1900 Phantom; Type: SAM

Left touch 661/Area Scan (51x91x1): Measurement grid: dx=15mm, dy=15mm
Maximum value of SAR (interpolated) = 0.728 mW/g

Left touch 661/Zoom Scan (5x5x7)/Cube 0: Measurement grid: dx=8mm, dy=8mm, dz=5mm
Reference Value = 8.01 V/m; Power Drift = -0.282 dB
Peak SAR (extrapolated) = 1.01 W/kg
SAR(1 g) = 0.664 mW/g; SAR(10 g) = 0.387 mW/g
Maximum value of SAR (measured) = 0.747 mW/g

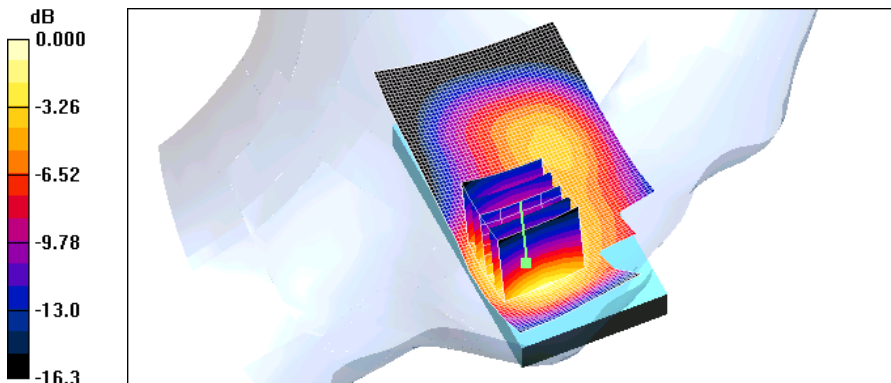

0 dB = 0.747mW/g

Test Laboratory: HCT CO., LTD
EUT Type: Cellular/PCS GSM Phone(850/1800/1900)
Liquid Temperature: 21.2 °C
Ambient Temperature: 21.4 °C
Test Date: Jul.13, 2009

DUT: QS100; Type: Bar; Serial: #1

Communication System: GSM 1900; Frequency: 1880 MHz; Duty Cycle: 1:8.3
Medium parameters used: $f = 1880$ MHz; $\sigma = 1.38$ mho/m; $\epsilon_r = 39$; $\rho = 1000$ kg/m³
Phantom section: Right Section ; Measurement SW: DASY4, V4.7 Build 80; Postprocessing SW: SEMCAD, V1.8 Build 176

DASY4 Configuration:

- Probe: ET3DV6 - SN1609; ConvF(5.12, 5.12, 5.12); Calibrated: 2009-03-17
- Sensor-Surface: 4mm (Mechanical Surface Detection)
- Electronics: DAE4 Sn869; Calibrated: 2008-09-03
- Phantom: 1800/1900 Phantom; Type: SAM

Right touch 661/Area Scan (51x91x1): Measurement grid: dx=15mm, dy=15mm
Maximum value of SAR (interpolated) = 0.507 mW/g

Right touch 661/Zoom Scan (5x5x7)/Cube 0: Measurement grid: dx=8mm, dy=8mm, dz=5mm
Reference Value = 9.03 V/m; Power Drift = -0.09 dB
Peak SAR (extrapolated) = 0.648 W/kg
SAR(1 g) = 0.466 mW/g; SAR(10 g) = 0.297 mW/g

Maximum value of SAR (measured) = 0.502 mW/g

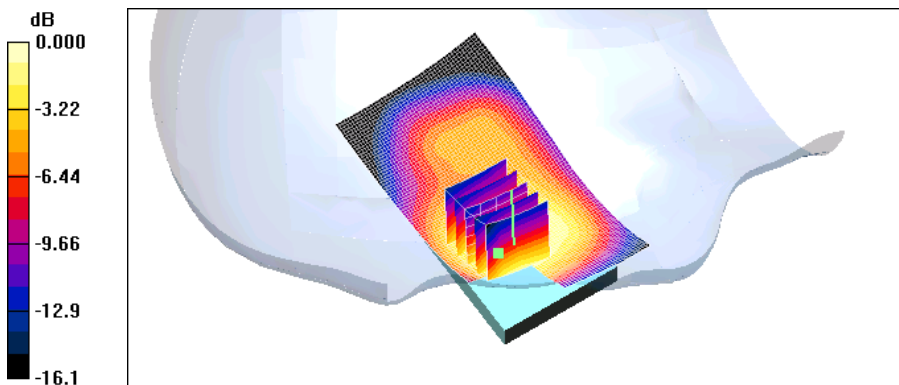

0 dB = 0.502mW/g

Test Laboratory: HCT CO., LTD
EUT Type: Cellular/PCS GSM Phone(850/1800/1900)
Liquid Temperature: 21.2 °C
Ambient Temperature: 21.4 °C
Test Date: Jul.13, 2009

DUT: QS100; Type: Bar; Serial: #1

Communication System: GSM 1900; Frequency: 1880 MHz; Duty Cycle: 1:8.3
Medium parameters used: $f = 1880$ MHz; $\sigma = 1.38$ mho/m; $\epsilon_r = 39$; $\rho = 1000$ kg/m³
Phantom section: Left Section ; Measurement SW: DASY4, V4.7 Build 80; Postprocessing SW: SEMCAD, V1.8 Build 176

DASY4 Configuration:

- Probe: ET3DV6 - SN1609; ConvF(5.12, 5.12, 5.12); Calibrated: 2009-03-17
- Sensor-Surface: 4mm (Mechanical Surface Detection)
- Electronics: DAE4 Sn869; Calibrated: 2008-09-03
- Phantom: 1800/1900 Phantom; Type: SAM

Left tilt 661/Area Scan (51x91x1): Measurement grid: dx=15mm, dy=15mm
Maximum value of SAR (interpolated) = 0.297 mW/g

Left tilt 661/Zoom Scan (5x5x7)/Cube 0: Measurement grid: dx=8mm, dy=8mm, dz=5mm
Reference Value = 11.5 V/m; Power Drift = -0.141 dB
Peak SAR (extrapolated) = 0.349 W/kg
SAR(1 g) = 0.259 mW/g; SAR(10 g) = 0.165 mW/g
Maximum value of SAR (measured) = 0.280 mW/g

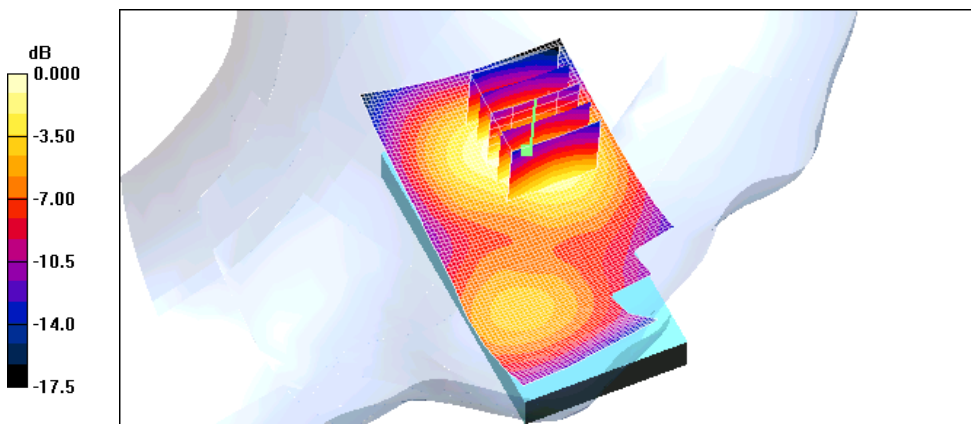

0 dB = 0.280mW/g

Test Laboratory: HCT CO., LTD
EUT Type: Cellular/PCS GSM Phone(850/1800/1900)
Liquid Temperature: 21.2 °C
Ambient Temperature: 21.4 °C
Test Date: Jul.13, 2009

DUT: QS100; Type: Bar; Serial: #1

Communication System: GSM 1900; Frequency: 1880 MHz; Duty Cycle: 1:8.3
Medium parameters used: $f = 1880$ MHz; $\sigma = 1.38$ mho/m; $\epsilon_r = 39$; $\rho = 1000$ kg/m³
Phantom section: Right Section ; Measurement SW: DASY4, V4.7 Build 80; Postprocessing SW: SEMCAD, V1.8 Build 176

DASY4 Configuration:

- Probe: ET3DV6 - SN1609; ConvF(5.12, 5.12, 5.12); Calibrated: 2009-03-17
- Sensor-Surface: 4mm (Mechanical Surface Detection)
- Electronics: DAE4 Sn869; Calibrated: 2008-09-03
- Phantom: 1800/1900 Phantom; Type: SAM

Right tilt 661/Area Scan (51x91x1): Measurement grid: dx=15mm, dy=15mm
Maximum value of SAR (interpolated) = 0.240 mW/g

Right tilt 661/Zoom Scan (5x5x7)/Cube 0: Measurement grid: dx=8mm, dy=8mm, dz=5mm
Reference Value = 11.6 V/m; Power Drift = -0.155 dB
Peak SAR (extrapolated) = 0.284 W/kg
SAR(1 g) = 0.209 mW/g; SAR(10 g) = 0.134 mW/g
Maximum value of SAR (measured) = 0.223 mW/g

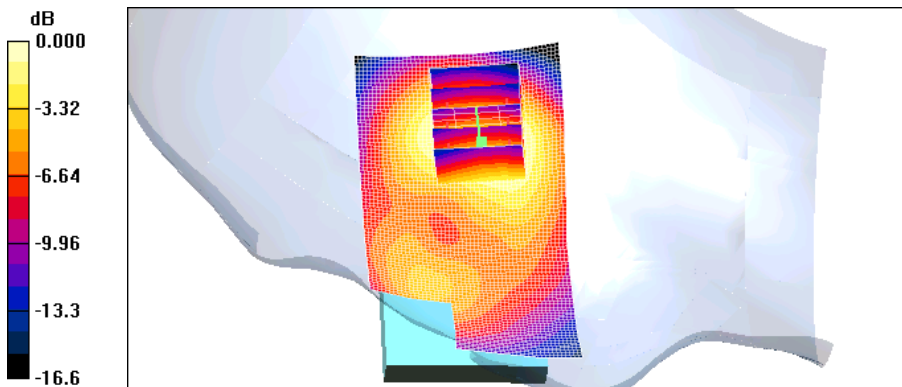

0 dB = 0.223mW/g

Test Laboratory: HCT CO., LTD
EUT Type: Cellular/PCS GSM Phone(850/1800/1900)
Liquid Temperature: 21.2 °C
Ambient Temperature: 21.4 °C
Test Date: Jul.12, 2009

DUT: QS100; Type: Bar; Serial: #1

Communication System: GSM 850; Frequency: 836.6 MHz; Duty Cycle: 1:8.3
Medium parameters used (interpolated): $f = 836.6$ MHz; $\sigma = 0.995$ mho/m; $\epsilon_r = 53.9$; $\rho = 1000$ kg/m³
Phantom section: Flat Section ; Measurement SW: DASY4, V4.7 Build 80; Postprocessing SW: SEMCAD, V1.8 Build 176

DASY4 Configuration:

- Probe: ET3DV6 - SN1609; ConvF(6.08, 6.08, 6.08); Calibrated: 2009-03-17
- Sensor-Surface: 4mm (Mechanical Surface Detection)
- Electronics: DAE4 Sn869; Calibrated: 2008-09-03
- Phantom: 835/900 Phantom ; Type: SAM

Body 190/Area Scan (51x91x1): Measurement grid: dx=15mm, dy=15mm

[Info: Interpolated medium parameters used for SAR evaluation.](#)

Maximum value of SAR (interpolated) = 0.605 mW/g

Body 190/Zoom Scan (5x5x7)/Cube 0: Measurement grid: dx=8mm, dy=8mm, dz=5mm

Reference Value = 14.6 V/m; Power Drift = -0.019 dB

Peak SAR (extrapolated) = 0.760 W/kg

SAR(1 g) = 0.573 mW/g; SAR(10 g) = 0.416 mW/g

[Info: Interpolated medium parameters used for SAR evaluation.](#)

Maximum value of SAR (measured) = 0.604 mW/g

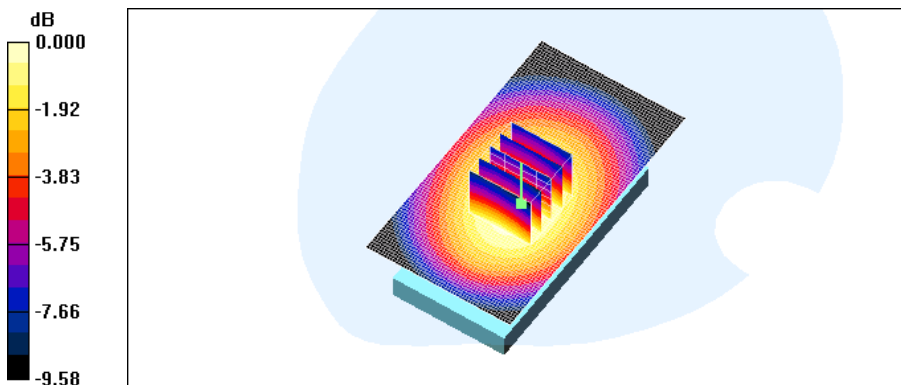

Test Laboratory: HCT CO., LTD
EUT Type: Cellular/PCS GSM Phone(850/1800/1900)
Liquid Temperature: 21.2 °C
Ambient Temperature: 21.4 °C
Test Date: Jul.12, 2009

DUT: QS100; Type: Bar; Serial: #1

Communication System: GSM 850; Frequency: 836.6 MHz; Duty Cycle: 1:4.15
Medium parameters used (interpolated): $f = 836.6$ MHz; $\sigma = 0.995$ mho/m; $\epsilon_r = 53.9$; $\rho = 1000$ kg/m³
Phantom section: Flat Section ; Measurement SW: DASY4, V4.7 Build 80; Postprocessing SW: SEMCAD, V1.8 Build 176

DASY4 Configuration:

- Probe: ET3DV6 - SN1609; ConvF(6.08, 6.08, 6.08); Calibrated: 2009-03-17
- Sensor-Surface: 4mm (Mechanical Surface Detection)
- Electronics: DAE4 Sn869; Calibrated: 2008-09-03
- Phantom: 835/900 Phantom ; Type: SAM

Body 190/Area Scan (51x91x1): Measurement grid: dx=15mm, dy=15mm

[Info: Interpolated medium parameters used for SAR evaluation.](#)

Maximum value of SAR (interpolated) = 0.934 mW/g

Body 190/Zoom Scan (5x5x7)/Cube 0: Measurement grid: dx=8mm, dy=8mm, dz=5mm

Reference Value = 18.3 V/m; Power Drift = -0.064 dB

Peak SAR (extrapolated) = 1.16 W/kg

SAR(1 g) = 0.883 mW/g; SAR(10 g) = 0.643 mW/g

[Info: Interpolated medium parameters used for SAR evaluation.](#)

Maximum value of SAR (measured) = 0.924 mW/g

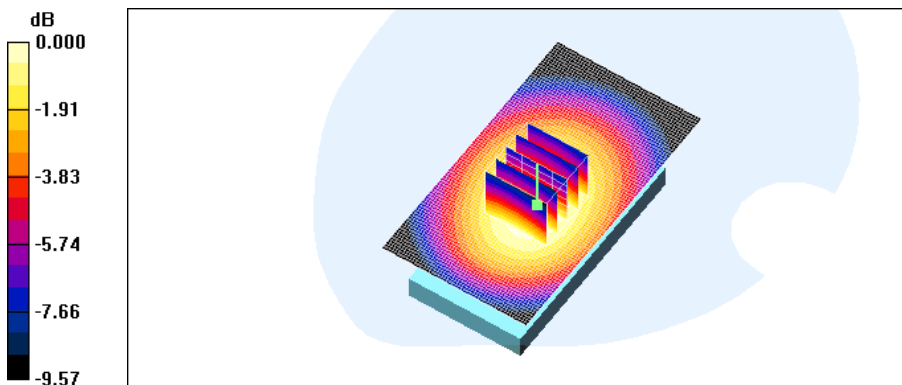

0 dB = 0.924mW/g

Test Laboratory: HCT CO., LTD
EUT Type: Cellular/PCS GSM Phone(850/1800/1900)
Liquid Temperature: 21.2 °C
Ambient Temperature: 21.4 °C
Test Date: Jul.12, 2009

DUT: QS100; Type: Bar; Serial: #1

Communication System: GSM 850; Frequency: 836.6 MHz; Duty Cycle: 1:2.77
Medium parameters used (interpolated): $f = 836.6$ MHz; $\sigma = 0.995$ mho/m; $\epsilon_r = 53.9$; $\rho = 1000$ kg/m³
Phantom section: Flat Section ; Measurement SW: DASY4, V4.7 Build 80; Postprocessing SW: SEMCAD, V1.8 Build 176

DASY4 Configuration:

- Probe: ET3DV6 - SN1609; ConvF(6.08, 6.08, 6.08); Calibrated: 2009-03-17
- Sensor-Surface: 4mm (Mechanical Surface Detection)
- Electronics: DAE4 Sn869; Calibrated: 2008-09-03
- Phantom: 835/900 Phantom ; Type: SAM

Body 190/Area Scan (51x91x1): Measurement grid: dx=15mm, dy=15mm

[Info: Interpolated medium parameters used for SAR evaluation.](#)

Maximum value of SAR (interpolated) = 1.12 mW/g

Body 190/Zoom Scan (5x5x7)/Cube 0: Measurement grid: dx=8mm, dy=8mm, dz=5mm

Reference Value = 19.7 V/m; Power Drift = -0.016 dB

Peak SAR (extrapolated) = 1.39 W/kg

SAR(1 g) = 1.05 mW/g; SAR(10 g) = 0.768 mW/g

[Info: Interpolated medium parameters used for SAR evaluation.](#)

Maximum value of SAR (measured) = 1.11 mW/g

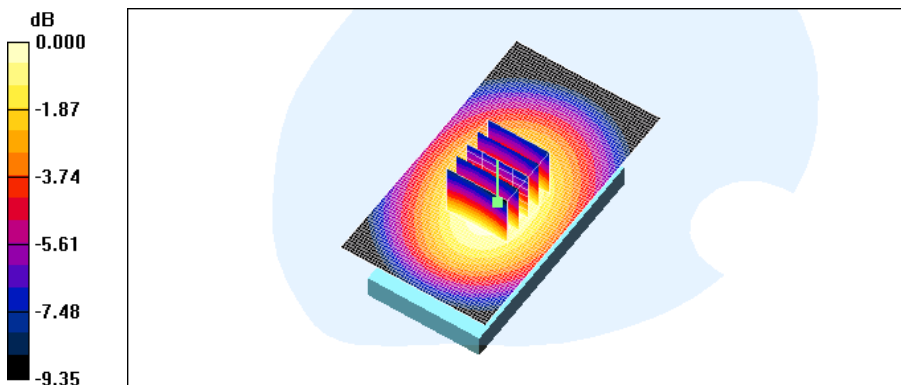

0 dB = 1.11mW/g

Test Laboratory: HCT CO., LTD
EUT Type: Cellular/PCS GSM Phone(850/1800/1900)
Liquid Temperature: 21.2 °C
Ambient Temperature: 21.4 °C
Test Date: Jul.12, 2009

DUT: QS100; Type: Bar; Serial: #1

Communication System: GSM 850; Frequency: 836.6 MHz; Duty Cycle: 1:2.075
Medium parameters used (interpolated): $f = 836.6$ MHz; $\sigma = 0.995$ mho/m; $\epsilon_r = 53.9$; $\rho = 1000$ kg/m³
Phantom section: Flat Section ; Measurement SW: DASY4, V4.7 Build 80; Postprocessing SW: SEMCAD, V1.8 Build 176

DASY4 Configuration:

- Probe: ET3DV6 - SN1609; ConvF(6.08, 6.08, 6.08); Calibrated: 2009-03-17
- Sensor-Surface: 4mm (Mechanical Surface Detection)
- Electronics: DAE4 Sn869; Calibrated: 2008-09-03
- Phantom: 835/900 Phantom ; Type: SAM

Body 190/Area Scan (51x91x1): Measurement grid: dx=15mm, dy=15mm

[Info: Interpolated medium parameters used for SAR evaluation.](#)

Maximum value of SAR (interpolated) = 1.29 mW/g

Body 190/Zoom Scan (5x5x7)/Cube 0: Measurement grid: dx=8mm, dy=8mm, dz=5mm

Reference Value = 21.1 V/m; Power Drift = -0.006 dB

Peak SAR (extrapolated) = 1.57 W/kg

SAR(1 g) = 1.2 mW/g; SAR(10 g) = 0.881 mW/g

[Info: Interpolated medium parameters used for SAR evaluation.](#)

Maximum value of SAR (measured) = 1.26 mW/g

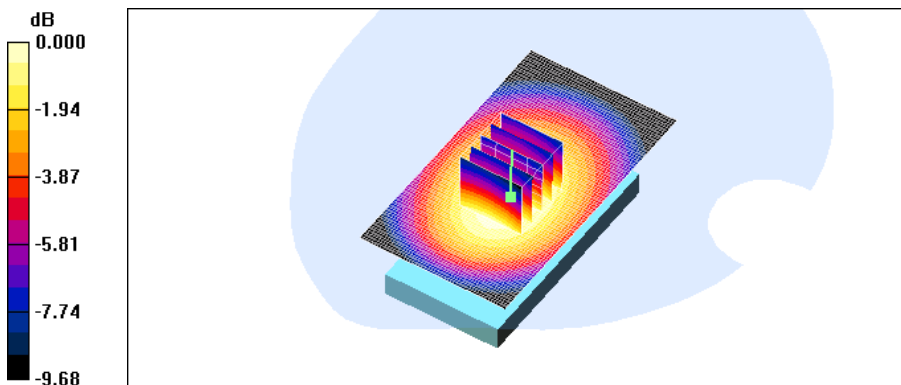

Test Laboratory: HCT CO., LTD
EUT Type: Cellular/PCS GSM Phone(850/1800/1900)
Liquid Temperature: 21.2 °C
Ambient Temperature: 21.4 °C
Test Date: Jul.12, 2009

DUT: QS100; Type: Bar; Serial: #1

Communication System: GSM 850; Frequency: 824.2 MHz; Duty Cycle: 1:2.075
Medium parameters used: $f = 825$ MHz; $\sigma = 0.985$ mho/m; $\epsilon_r = 53.9$; $\rho = 1000$ kg/m³
Phantom section: Flat Section ; Measurement SW: DASY4, V4.7 Build 80; Postprocessing SW: SEMCAD, V1.8 Build 176

DASY4 Configuration:

- Probe: ET3DV6 - SN1609; ConvF(6.08, 6.08, 6.08); Calibrated: 2009-03-17
- Sensor-Surface: 4mm (Mechanical Surface Detection)
- Electronics: DAE4 Sn869; Calibrated: 2008-09-03
- Phantom: 835/900 Phantom ; Type: SAM

Body 128/Area Scan (51x91x1): Measurement grid: dx=15mm, dy=15mm
Maximum value of SAR (interpolated) = 1.08 mW/g

Body 128/Zoom Scan (5x5x7)/Cube 0: Measurement grid: dx=8mm, dy=8mm, dz=5mm
Reference Value = 19.5 V/m; Power Drift = -0.199 dB
Peak SAR (extrapolated) = 1.30 W/kg
SAR(1 g) = 1 mW/g; SAR(10 g) = 0.734 mW/g
Maximum value of SAR (measured) = 1.06 mW/g

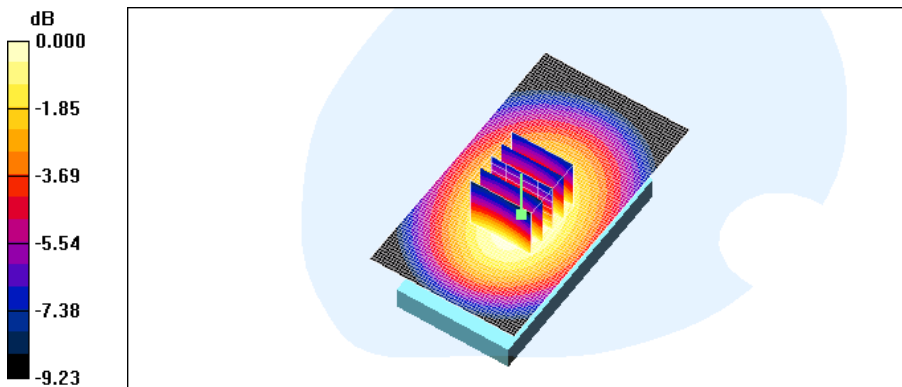

Test Laboratory: HCT CO., LTD
EUT Type: Cellular/PCS GSM Phone(850/1800/1900)
Liquid Temperature: 21.2 °C
Ambient Temperature: 21.4 °C
Test Date: Jul.12, 2009

DUT: QS100; Type: Bar; Serial: #1

Communication System: GSM 850; Frequency: 848.8 MHz;Duty Cycle: 1:2.075
Medium parameters used (interpolated): $f = 848.8$ MHz; $\sigma = 1.01$ mho/m; $\epsilon_r = 53.7$; $\rho = 1000$ kg/m³
Phantom section: Flat Section ; Measurement SW: DASY4, V4.7 Build 80; Postprocessing SW: SEMCAD, V1.8 Build 176

DASY4 Configuration:

- Probe: ET3DV6 - SN1609; ConvF(6.08, 6.08, 6.08); Calibrated: 2009-03-17
- Sensor-Surface: 4mm (Mechanical Surface Detection)
- Electronics: DAE4 Sn869; Calibrated: 2008-09-03
- Phantom: 835/900 Phantom ; Type: SAM

Body 251/Area Scan (51x91x1): Measurement grid: dx=15mm, dy=15mm

[Info: Interpolated medium parameters used for SAR evaluation.](#)

Maximum value of SAR (interpolated) = 1.44 mW/g

Body 251/Zoom Scan (5x5x7)/Cube 0: Measurement grid: dx=8mm, dy=8mm, dz=5mm

Reference Value = 22.9 V/m; Power Drift = -0.025 dB

Peak SAR (extrapolated) = 1.78 W/kg

SAR(1 g) = 1.36 mW/g; SAR(10 g) = 0.992 mW/g

[Info: Interpolated medium parameters used for SAR evaluation.](#)

Maximum value of SAR (measured) = 1.44 mW/g

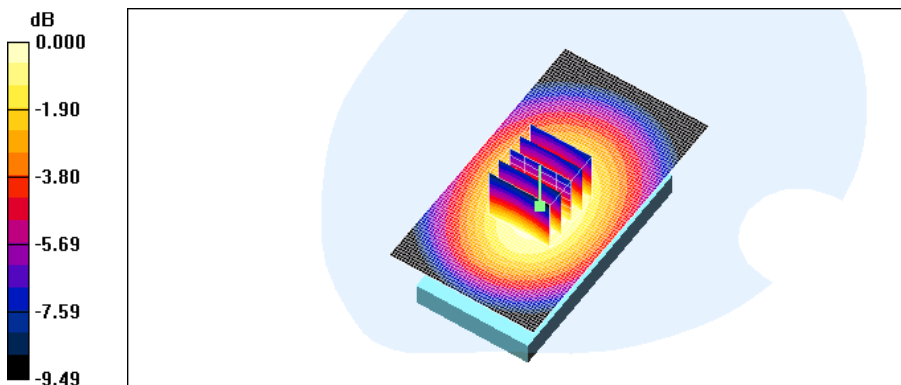

Test Laboratory: HCT CO., LTD
EUT Type: Cellular/PCS GSM Phone(850/1800/1900)
Liquid Temperature: 21.2 °C
Ambient Temperature: 21.4 °C
Test Date: Jul.12, 2009

DUT: QS100; Type: Bar; Serial: #1

Communication System: GSM 850; Frequency: 848.8 MHz; Duty Cycle: 1:2.075
Medium parameters used (interpolated): $f = 848.8$ MHz; $\sigma = 1.01$ mho/m; $\epsilon_r = 53.7$; $\rho = 1000$ kg/m³
Phantom section: Flat Section ; Measurement SW: DASY4, V4.7 Build 80; Postprocessing SW: SEMCAD, V1.8 Build 176

DASY4 Configuration:

- Probe: ET3DV6 - SN1609; ConvF(6.08, 6.08, 6.08); Calibrated: 2009-03-17
- Sensor-Surface: 4mm (Mechanical Surface Detection)
- Electronics: DAE4 Sn869; Calibrated: 2008-09-03
- Phantom: 835/900 Phantom ; Type: SAM

Body 251/Area Scan (51x91x1): Measurement grid: dx=15mm, dy=15mm

[Info: Interpolated medium parameters used for SAR evaluation.](#)

Maximum value of SAR (interpolated) = 1.41 mW/g

Body 251/Zoom Scan (5x5x7)/Cube 0: Measurement grid: dx=8mm, dy=8mm, dz=5mm

Reference Value = 22.0 V/m; Power Drift = -0.140 dB

Peak SAR (extrapolated) = 1.71 W/kg

SAR(1 g) = 1.33 mW/g; SAR(10 g) = 0.975 mW/g

[Info: Interpolated medium parameters used for SAR evaluation.](#)

Maximum value of SAR (measured) = 1.40 mW/g

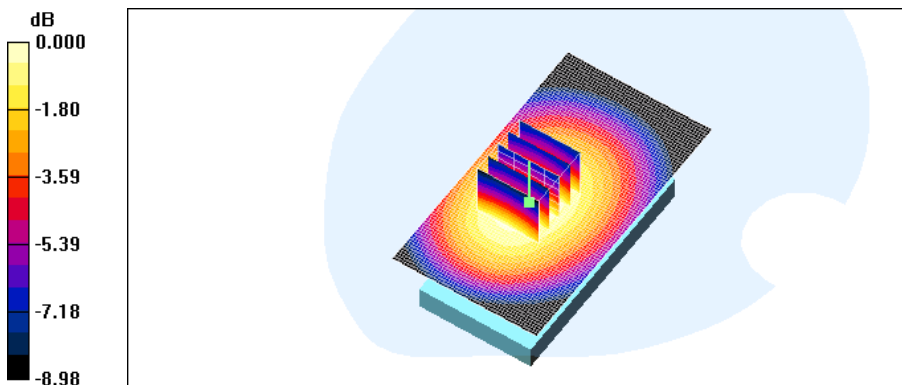

Test Laboratory: HCT CO., LTD
EUT Type: Cellular/PCS GSM Phone(850/1800/1900)
Liquid Temperature: 21.2 °C
Ambient Temperature: 21.4 °C
Test Date: Jul.12, 2009

DUT: QS100; Type: Bar; Serial: #1

Communication System: GSM 850; Frequency: 848.8 MHz;Duty Cycle: 1:8.3
Medium parameters used (interpolated): $f = 848.8$ MHz; $\sigma = 1.01$ mho/m; $\epsilon_r = 53.7$; $\rho = 1000$ kg/m³
Phantom section: Flat Section ; Measurement SW: DASY4, V4.7 Build 80; Postprocessing SW: SEMCAD, V1.8 Build 176

DASY4 Configuration:

- Probe: ET3DV6 - SN1609; ConvF(6.08, 6.08, 6.08); Calibrated: 2009-03-17
- Sensor-Surface: 4mm (Mechanical Surface Detection)
- Electronics: DAE4 Sn869; Calibrated: 2008-09-03
- Phantom: 835/900 Phantom ; Type: SAM

Body 251/Area Scan (51x91x1): Measurement grid: dx=15mm, dy=15mm

[Info: Interpolated medium parameters used for SAR evaluation.](#)

Maximum value of SAR (interpolated) = 0.682 mW/g

Body 251/Zoom Scan (5x5x7)/Cube 0: Measurement grid: dx=8mm, dy=8mm, dz=5mm

Reference Value = 15.6 V/m; Power Drift = -0.023 dB

Peak SAR (extrapolated) = 0.856 W/kg

SAR(1 g) = 0.646 mW/g; SAR(10 g) = 0.468 mW/g

[Info: Interpolated medium parameters used for SAR evaluation.](#)

Maximum value of SAR (measured) = 0.688 mW/g

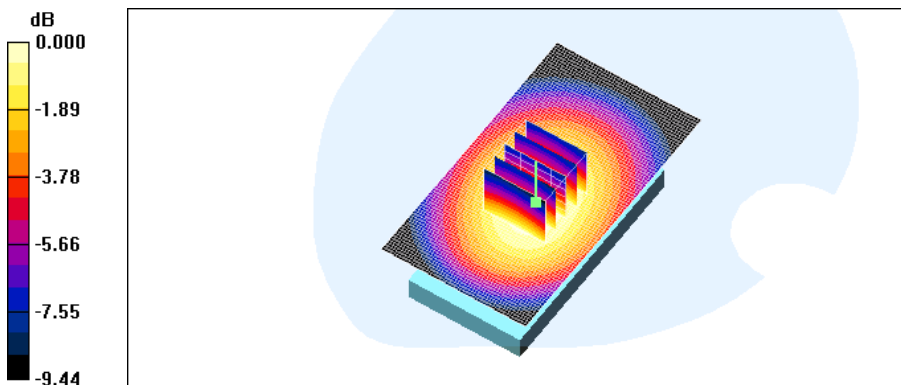

Test Laboratory: HCT CO., LTD
EUT Type: Cellular/PCS GSM Phone(850/1800/1900)
Liquid Temperature: 21.2 °C
Ambient Temperature: 21.4 °C
Test Date: Jul.13, 2009

DUT: QS100; Type: Bar; Serial: #1

Communication System: GSM 1900; Frequency: 1880 MHz; Duty Cycle: 1:8.3
Medium parameters used: $f = 1880$ MHz; $\sigma = 1.48$ mho/m; $\epsilon_r = 52.4$; $\rho = 1000$ kg/m³
Phantom section: Flat Section ; Measurement SW: DASY4, V4.7 Build 80; Postprocessing SW: SEMCAD, V1.8 Build 176

DASY4 Configuration:

- Probe: ET3DV6 - SN1609; ConvF(4.61, 4.61, 4.61); Calibrated: 2009-03-17
- Sensor-Surface: 4mm (Mechanical Surface Detection)
- Electronics: DAE4 Sn869; Calibrated: 2008-09-03
- Phantom: 1800/1900 Phantom; Type: SAM

Body 661/Area Scan (51x91x1): Measurement grid: dx=15mm, dy=15mm
Maximum value of SAR (interpolated) = 0.219 mW/g

Body 661/Zoom Scan (5x5x7)/Cube 0: Measurement grid: dx=8mm, dy=8mm, dz=5mm
Reference Value = 8.67 V/m; Power Drift = 0.060 dB
Peak SAR (extrapolated) = 0.240 W/kg
SAR(1 g) = 0.198 mW/g; SAR(10 g) = 0.126 mW/g
Maximum value of SAR (measured) = 0.217 mW/g

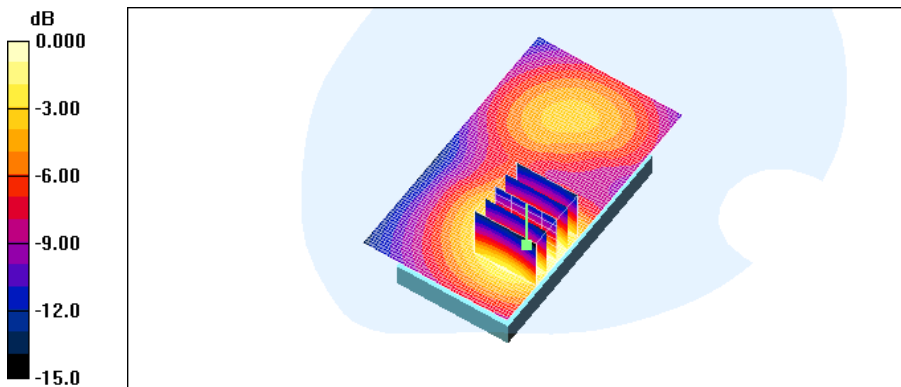

Test Laboratory: HCT CO., LTD
EUT Type: Cellular/PCS GSM Phone(850/1800/1900)
Liquid Temperature: 21.2 °C
Ambient Temperature: 21.4 °C
Test Date: Jul.13, 2009

DUT: QS100; Type: Bar; Serial: #1

Communication System: GSM 1900; Frequency: 1880 MHz; Duty Cycle: 1:4.15
Medium parameters used: $f = 1880$ MHz; $\sigma = 1.48$ mho/m; $\epsilon_r = 52.4$; $\rho = 1000$ kg/m³
Phantom section: Flat Section ; Measurement SW: DASY4, V4.7 Build 80; Postprocessing SW: SEMCAD, V1.8 Build 176

DASY4 Configuration:

- Probe: ET3DV6 - SN1609; ConvF(4.61, 4.61, 4.61); Calibrated: 2009-03-17
- Sensor-Surface: 4mm (Mechanical Surface Detection)
- Electronics: DAE4 Sn869; Calibrated: 2008-09-03
- Phantom: 1800/1900 Phantom; Type: SAM

Body 661/Area Scan (51x91x1): Measurement grid: dx=15mm, dy=15mm
Maximum value of SAR (interpolated) = 0.429 mW/g

Body 661/Zoom Scan (5x5x7)/Cube 0: Measurement grid: dx=8mm, dy=8mm, dz=5mm
Reference Value = 12.2 V/m; Power Drift = 0.013 dB
Peak SAR (extrapolated) = 0.474 W/kg
SAR(1 g) = 0.387 mW/g; SAR(10 g) = 0.248 mW/g
Maximum value of SAR (measured) = 0.425 mW/g

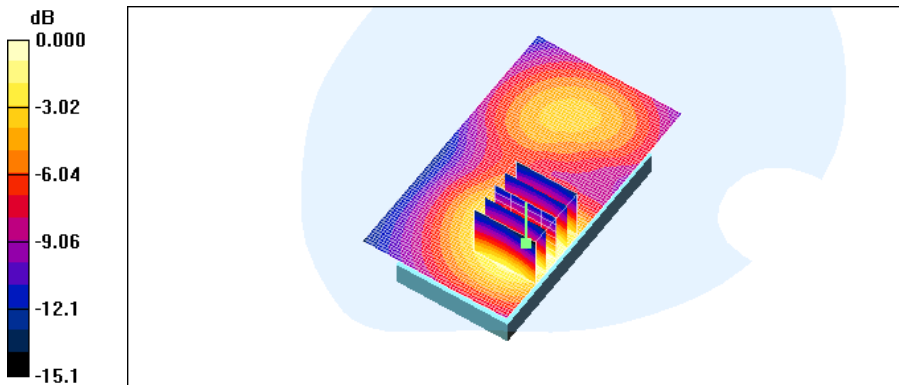

0 dB = 0.425mW/g

Test Laboratory: HCT CO., LTD
EUT Type: Cellular/PCS GSM Phone(850/1800/1900)
Liquid Temperature: 21.2 °C
Ambient Temperature: 21.4 °C
Test Date: Jul.13, 2009

DUT: QS100; Type: Bar; Serial: #1

Communication System: GSM 1900; Frequency: 1880 MHz; Duty Cycle: 1:2.77
Medium parameters used: $f = 1880$ MHz; $\sigma = 1.48$ mho/m; $\epsilon_r = 52.4$; $\rho = 1000$ kg/m³
Phantom section: Flat Section ; Measurement SW: DASY4, V4.7 Build 80; Postprocessing SW: SEMCAD, V1.8 Build 176

DASY4 Configuration:

- Probe: ET3DV6 - SN1609; ConvF(4.61, 4.61, 4.61); Calibrated: 2009-03-17
- Sensor-Surface: 4mm (Mechanical Surface Detection)
- Electronics: DAE4 Sn869; Calibrated: 2008-09-03
- Phantom: 1800/1900 Phantom; Type: SAM

Body 661/Area Scan (51x91x1): Measurement grid: dx=15mm, dy=15mm
Maximum value of SAR (interpolated) = 0.637 mW/g

Body 661/Zoom Scan (5x5x7)/Cube 0: Measurement grid: dx=8mm, dy=8mm, dz=5mm
Reference Value = 14.9 V/m; Power Drift = -0.011 dB
Peak SAR (extrapolated) = 0.697 W/kg
SAR(1 g) = 0.572 mW/g; SAR(10 g) = 0.364 mW/g
Maximum value of SAR (measured) = 0.630 mW/g

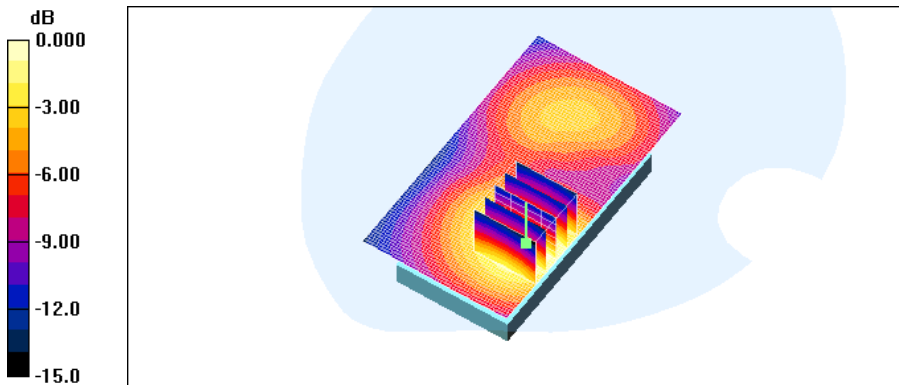

Test Laboratory: HCT CO., LTD
EUT Type: Cellular/PCS GSM Phone(850/1800/1900)
Liquid Temperature: 21.2 °C
Ambient Temperature: 21.4 °C
Test Date: Jul.13, 2009

DUT: QS100; Type: Bar; Serial: #1

Communication System: GSM 1900; Frequency: 1880 MHz; Duty Cycle: 1:2.075
Medium parameters used: $f = 1880$ MHz; $\sigma = 1.48$ mho/m; $\epsilon_r = 52.4$; $\rho = 1000$ kg/m³
Phantom section: Flat Section ; Measurement SW: DASY4, V4.7 Build 80; Postprocessing SW: SEMCAD, V1.8 Build 176

DASY4 Configuration:

- Probe: ET3DV6 - SN1609; ConvF(4.61, 4.61, 4.61); Calibrated: 2009-03-17
- Sensor-Surface: 4mm (Mechanical Surface Detection)
- Electronics: DAE4 Sn869; Calibrated: 2008-09-03
- Phantom: 1800/1900 Phantom; Type: SAM

Body 661/Area Scan (51x91x1): Measurement grid: dx=15mm, dy=15mm
Maximum value of SAR (interpolated) = 0.844 mW/g

Body 661/Zoom Scan (5x5x7)/Cube 0: Measurement grid: dx=8mm, dy=8mm, dz=5mm
Reference Value = 16.9 V/m; Power Drift = -0.160 dB
Peak SAR (extrapolated) = 0.929 W/kg
SAR(1 g) = 0.765 mW/g; SAR(10 g) = 0.490 mW/g
Maximum value of SAR (measured) = 0.844 mW/g

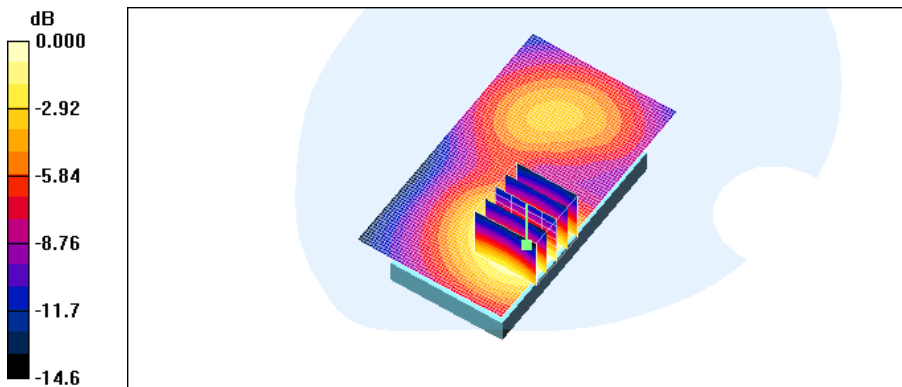

0 dB = 0.844mW/g

Test Laboratory: HCT CO., LTD
EUT Type: Cellular/PCS GSM Phone(850/1800/1900)
Liquid Temperature: 21.2 °C
Ambient Temperature: 21.4 °C
Test Date: Jul.13, 2009

DUT: QS100; Type: Bar; Serial: #1

Communication System: GSM 1900; Frequency: 1880 MHz; Duty Cycle: 1:2.075
Medium parameters used: $f = 1880$ MHz; $\sigma = 1.48$ mho/m; $\epsilon_r = 52.4$; $\rho = 1000$ kg/m³
Phantom section: Flat Section ; Measurement SW: DASY4, V4.7 Build 80; Postprocessing SW: SEMCAD, V1.8 Build 176

DASY4 Configuration:

- Probe: ET3DV6 - SN1609; ConvF(4.61, 4.61, 4.61); Calibrated: 2009-03-17
- Sensor-Surface: 4mm (Mechanical Surface Detection)
- Electronics: DAE4 Sn869; Calibrated: 2008-09-03
- Phantom: 1800/1900 Phantom; Type: SAM

Body 661/Area Scan (51x91x1): Measurement grid: dx=15mm, dy=15mm
Maximum value of SAR (interpolated) = 0.386 mW/g

Body 661/Zoom Scan (5x5x7)/Cube 0: Measurement grid: dx=8mm, dy=8mm, dz=5mm
Reference Value = 13.8 V/m; Power Drift = -0.089 dB
Peak SAR (extrapolated) = 0.442 W/kg
SAR(1 g) = 0.342 mW/g; SAR(10 g) = 0.213 mW/g
Maximum value of SAR (measured) = 0.374 mW/g

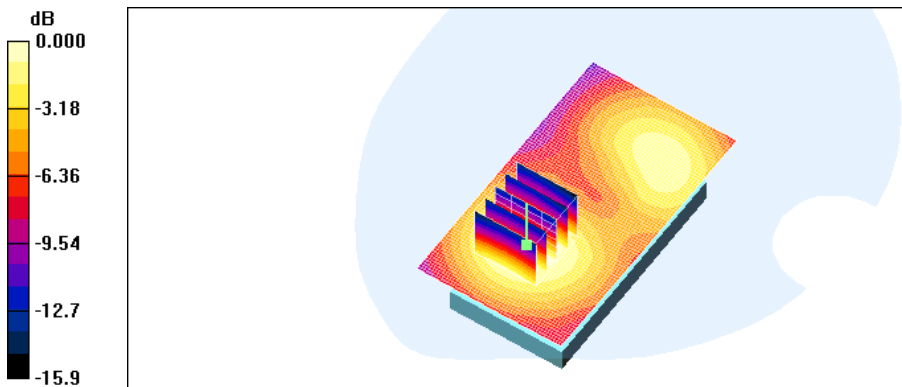

Test Laboratory: HCT CO., LTD
EUT Type: Cellular/PCS GSM Phone(850/1800/1900)
Liquid Temperature: 21.2 °C
Ambient Temperature: 21.4 °C
Test Date: Jul.13, 2009

DUT: QS100; Type: Bar; Serial: #1

Communication System: GSM 1900; Frequency: 1880 MHz; Duty Cycle: 1:8.3
Medium parameters used: $f = 1880$ MHz; $\sigma = 1.48$ mho/m; $\epsilon_r = 52.4$; $\rho = 1000$ kg/m³
Phantom section: Flat Section ; Measurement SW: DASY4, V4.7 Build 80; Postprocessing SW: SEMCAD, V1.8 Build 176

DASY4 Configuration:

- Probe: ET3DV6 - SN1609; ConvF(4.61, 4.61, 4.61); Calibrated: 2009-03-17
- Sensor-Surface: 4mm (Mechanical Surface Detection)
- Electronics: DAE4 Sn869; Calibrated: 2008-09-03
- Phantom: 1800/1900 Phantom; Type: SAM

Body 661/Area Scan (51x91x1): Measurement grid: dx=15mm, dy=15mm
Maximum value of SAR (interpolated) = 0.221 mW/g

Body 661/Zoom Scan (5x5x7)/Cube 0: Measurement grid: dx=8mm, dy=8mm, dz=5mm
Reference Value = 9.10 V/m; Power Drift = 0.029 dB
Peak SAR (extrapolated) = 0.252 W/kg
SAR(1 g) = 0.207 mW/g; SAR(10 g) = 0.131 mW/g
Maximum value of SAR (measured) = 0.228 mW/g

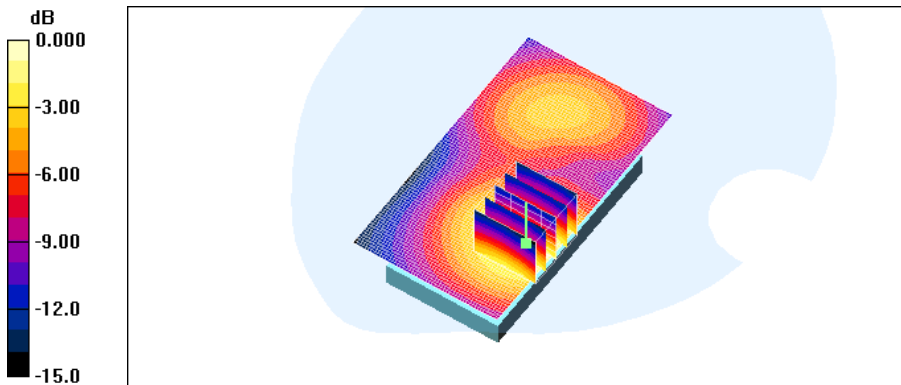

Test Laboratory: HCT CO., LTD
EUT Type: Cellular/PCS GSM Phone(850/1800/1900)
Liquid Temperature: 21.2 °C
Ambient Temperature: 21.4 °C
Test Date: Jul.12, 2009

DUT: QS100; Type: Bar; Serial: #1

Communication System: GSM 850; Frequency: 848.8 MHz; Duty Cycle: 1:8.3
Medium parameters used (interpolated): $f = 848.8$ MHz; $\sigma = 0.885$ mho/m; $\epsilon_r = 40.5$; $\rho = 1000$ kg/m³
Phantom section: Right Section ; Measurement SW: DASY4, V4.7 Build 80; Postprocessing SW: SEMCAD, V1.8 Build 176

DASY4 Configuration:

- Probe: ET3DV6 - SN1609; ConvF(6.25, 6.25, 6.25); Calibrated: 2009-03-17
- Sensor-Surface: 4mm (Mechanical Surface Detection)
- Electronics: DAE4 Sn869; Calibrated: 2008-09-03
- Phantom: 835/900 Phantom ; Type: SAM

Right touch 251/Area Scan (51x91x1): Measurement grid: dx=15mm, dy=15mm

[Info: Interpolated medium parameters used for SAR evaluation.](#)

Maximum value of SAR (interpolated) = 1.04 mW/g

Right touch 251/Zoom Scan (5x5x7)/Cube 0: Measurement grid: dx=8mm, dy=8mm, dz=5mm

Reference Value = 9.07 V/m; Power Drift = -0.082 dB

Peak SAR (extrapolated) = 1.24 W/kg

SAR(1 g) = 0.993 mW/g; SAR(10 g) = 0.738 mW/g

[Info: Interpolated medium parameters used for SAR evaluation.](#)

Maximum value of SAR (measured) = 1.06 mW/g

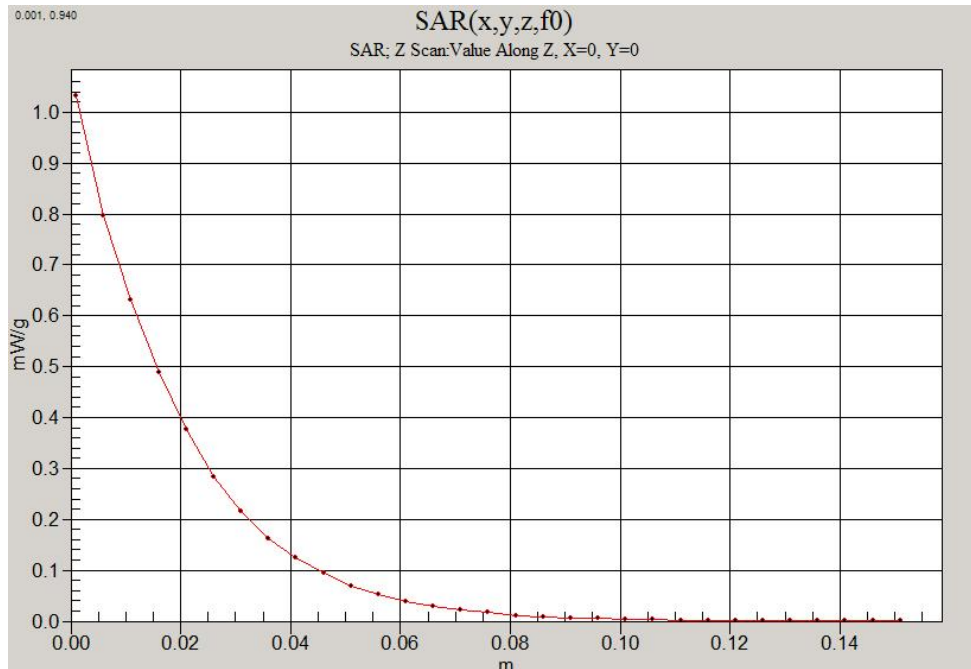

Test Laboratory: HCT CO., LTD
EUT Type: Cellular/PCS GSM Phone(850/1800/1900)
Liquid Temperature: 21.2 °C
Ambient Temperature: 21.4 °C
Test Date: Jul.12, 2009

DUT: QS100; Type: Bar; Serial: #1

Communication System: GSM 850; Frequency: 848.8 MHz; Duty Cycle: 1:2.075
Medium parameters used (interpolated): $f = 848.8$ MHz; $\sigma = 1.01$ mho/m; $\epsilon_r = 53.7$; $\rho = 1000$ kg/m³
Phantom section: Flat Section ; Measurement SW: DASY4, V4.7 Build 80; Postprocessing SW: SEMCAD, V1.8 Build 176

DASY4 Configuration:

- Probe: ET3DV6 - SN1609; ConvF(6.08, 6.08, 6.08); Calibrated: 2009-03-17
- Sensor-Surface: 4mm (Mechanical Surface Detection)
- Electronics: DAE4 Sn869; Calibrated: 2008-09-03
- Phantom: 835/900 Phantom ; Type: SAM

Body 251/Area Scan (51x91x1): Measurement grid: dx=15mm, dy=15mm

[Info: Interpolated medium parameters used for SAR evaluation.](#)

Maximum value of SAR (interpolated) = 1.44 mW/g

Body 251/Zoom Scan (5x5x7)/Cube 0: Measurement grid: dx=8mm, dy=8mm, dz=5mm

Reference Value = 22.9 V/m; Power Drift = -0.025 dB

Peak SAR (extrapolated) = 1.78 W/kg

SAR(1 g) = 1.36 mW/g; SAR(10 g) = 0.992 mW/g

[Info: Interpolated medium parameters used for SAR evaluation.](#)

Maximum value of SAR (measured) = 1.44 mW/g

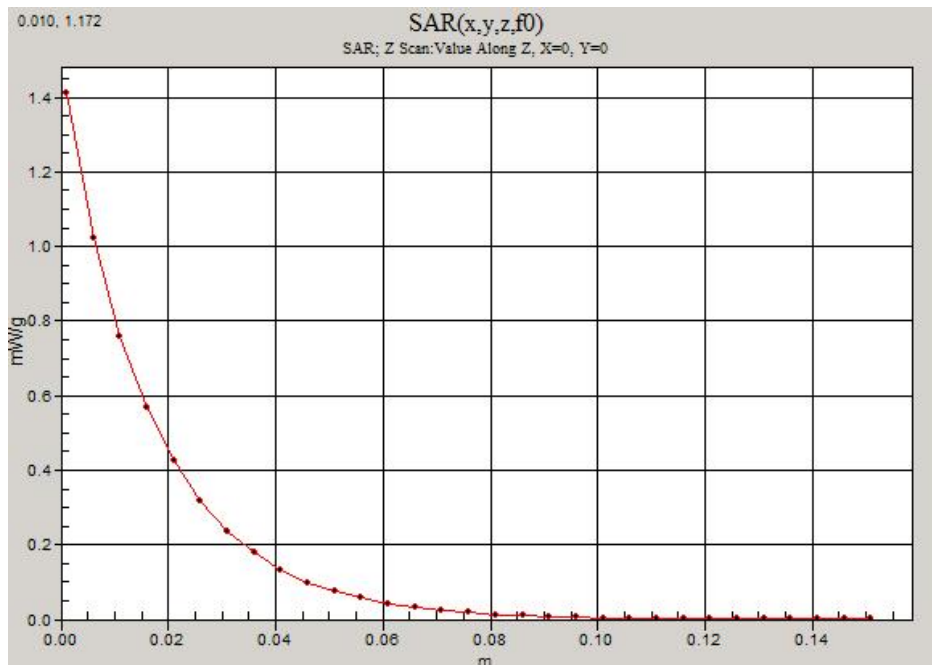

Test Laboratory: HCT CO., LTD
EUT Type: Cellular/PCS GSM Phone(850/1800/1900)
Liquid Temperature: 21.2 °C
Ambient Temperature: 21.4 °C
Test Date: Jul.13, 2009

DUT: QS100; Type: Bar; Serial: #1

Communication System: GSM 1900; Frequency: 1880 MHz; Duty Cycle: 1:8.3
Medium parameters used: $f = 1880$ MHz; $\sigma = 1.38$ mho/m; $\epsilon_r = 39$; $\rho = 1000$ kg/m³
Phantom section: Left Section ; Measurement SW: DASY4, V4.7 Build 80; Postprocessing SW: SEMCAD, V1.8 Build 176

DASY4 Configuration:

- Probe: ET3DV6 - SN1609; ConvF(5.12, 5.12, 5.12); Calibrated: 2009-03-17
- Sensor-Surface: 4mm (Mechanical Surface Detection)
- Electronics: DAE4 Sn869; Calibrated: 2008-09-03
- Phantom: 1800/1900 Phantom; Type: SAM

Left touch 661/Area Scan (51x91x1): Measurement grid: dx=15mm, dy=15mm
Maximum value of SAR (interpolated) = 0.728 mW/g

Left touch 661/Zoom Scan (5x5x7)/Cube 0: Measurement grid: dx=8mm, dy=8mm, dz=5mm
Reference Value = 8.01 V/m; Power Drift = -0.282 dB
Peak SAR (extrapolated) = 1.01 W/kg
SAR(1 g) = 0.664 mW/g; SAR(10 g) = 0.387 mW/g
Maximum value of SAR (measured) = 0.747 mW/g

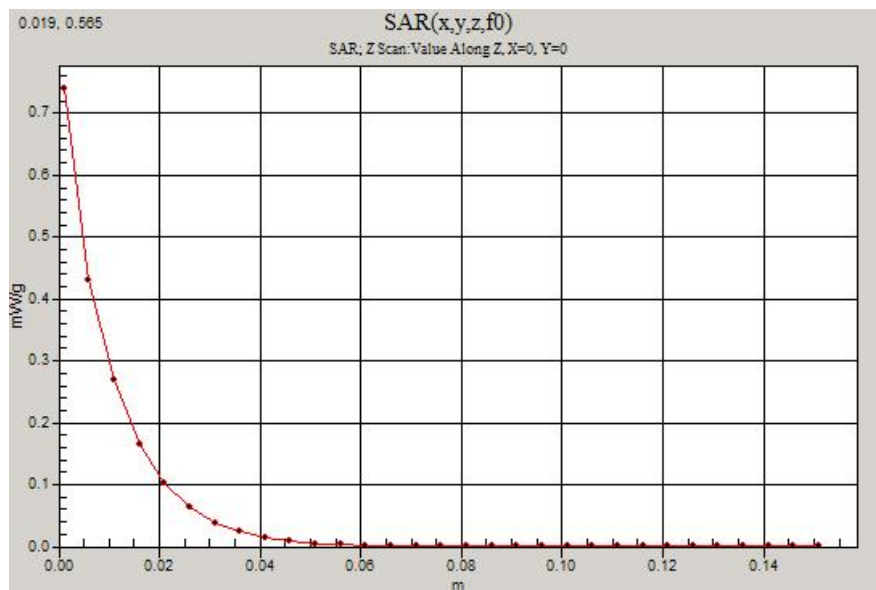

Test Laboratory: HCT CO., LTD
EUT Type: Cellular/PCS GSM Phone(850/1800/1900)
Liquid Temperature: 21.2 °C
Ambient Temperature: 21.4 °C
Test Date: Jul.13, 2009

DUT: QS100; Type: Bar; Serial: #1

Communication System: GSM 1900; Frequency: 1880 MHz; Duty Cycle: 1:2.075
Medium parameters used: $f = 1880$ MHz; $\sigma = 1.48$ mho/m; $\epsilon_r = 52.4$; $\rho = 1000$ kg/m³
Phantom section: Flat Section ; Measurement SW: DASY4, V4.7 Build 80; Postprocessing SW: SEMCAD, V1.8 Build 176

DASY4 Configuration:

- Probe: ET3DV6 - SN1609; ConvF(4.61, 4.61, 4.61); Calibrated: 2009-03-17
- Sensor-Surface: 4mm (Mechanical Surface Detection)
- Electronics: DAE4 Sn869; Calibrated: 2008-09-03
- Phantom: 1800/1900 Phantom; Type: SAM

Body 661/Area Scan (51x91x1): Measurement grid: dx=15mm, dy=15mm
Maximum value of SAR (interpolated) = 0.844 mW/g

Body 661/Zoom Scan (5x5x7)/Cube 0: Measurement grid: dx=8mm, dy=8mm, dz=5mm
Reference Value = 16.9 V/m; Power Drift = -0.160 dB
Peak SAR (extrapolated) = 0.929 W/kg
SAR(1 g) = 0.765 mW/g; SAR(10 g) = 0.490 mW/g
Maximum value of SAR (measured) = 0.844 mW/g

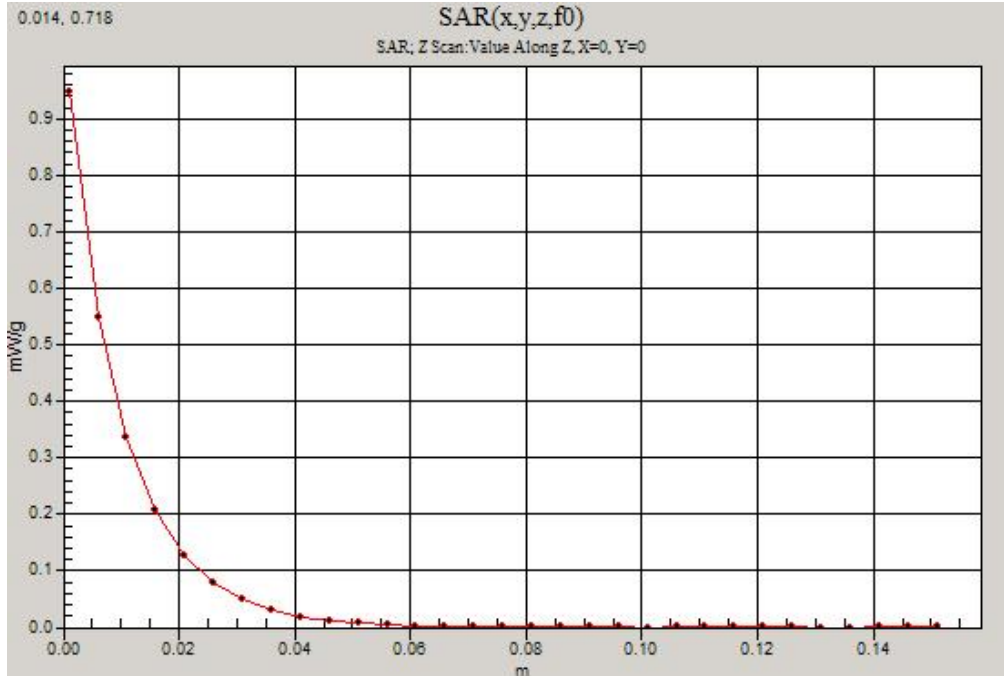

Attachment 2. – Dipole Validation Plots

■ Validation Data (835 MHz Head)

Test Laboratory: HCT CO., LTD
Input Power 100 mW (20 dBm)
Liquid Temp: 21.2 °C
Test Date: Jul.12, 2009

DUT: Dipole 835 MHz; Type: D835V2; Serial: 441

Communication System: CW; Frequency: 835 MHz; Duty Cycle: 1:1
Medium parameters used: $f = 835$ MHz; $\sigma = 0.872$ mho/m; $\epsilon_r = 40.7$; $\rho = 1000$ kg/m³
Phantom section: Flat Section ; Measurement SW: DASY4, V4.7 Build 80; Postprocessing SW: SEMCAD, V1.8 Build 176

DASY4 Configuration:

- Probe: ET3DV6 - SN1609; ConvF(6.25, 6.25, 6.25); Calibrated: 2009-03-17
- Sensor-Surface: 4mm (Mechanical Surface Detection)
- Electronics: DAE4 Sn869; Calibrated: 2008-09-03
- Phantom: SAM 835/900 MHz; Type: SAM

Validation 835MHz/Area Scan (61x61x1): Measurement grid: dx=15mm, dy=15mm
Maximum value of SAR (interpolated) = 1.02 mW/g

Validation 835MHz/Zoom Scan (5x5x7)/Cube 0: Measurement grid: dx=8mm, dy=8mm, dz=5mm
Reference Value = 35.1 V/m; Power Drift = 0.031 dB
Peak SAR (extrapolated) = 1.47 W/kg
SAR(1 g) = 0.983 mW/g; SAR(10 g) = 0.640 mW/g
Maximum value of SAR (measured) = 1.06 mW/g

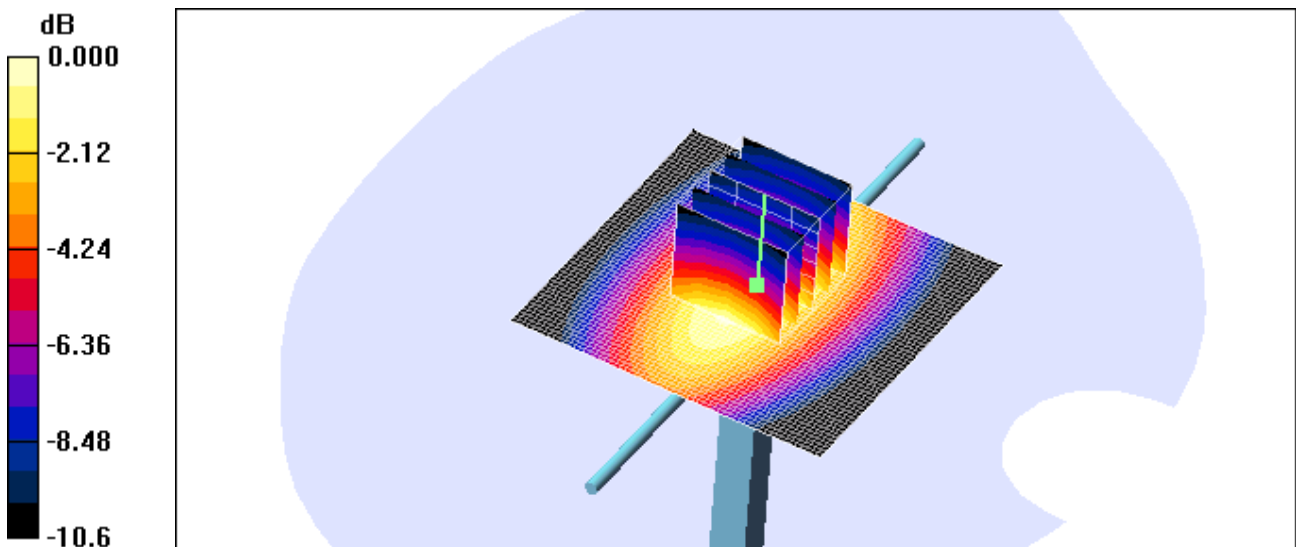

0 dB = 1.06mW/g

■ Validation Data (1900 MHz Head)

Test Laboratory: HCT CO., LTD
Input Power 100 mW (20 dBm)
Liquid Temp: 21.2 °C
Test Date: Jul.13, 2009

DUT: Dipole 1900 MHz; Type: D1900V2; Serial: 5d032

Communication System: CW; Frequency: 1900 MHz; Duty Cycle: 1:1
Medium parameters used: $f = 1900$ MHz; $\sigma = 1.41$ mho/m; $\epsilon_r = 38.9$; $\rho = 1000$ kg/m³
Phantom section: Flat Section ; Measurement SW: DASY4, V4.7 Build 80; Postprocessing SW: SEMCAD, V1.8 Build 176

DASY4 Configuration:

- Probe: ET3DV6 - SN1609; ConvF(5.12, 5.12, 5.12); Calibrated: 2009-03-17
- Sensor-Surface: 4mm (Mechanical Surface Detection)
- Electronics: DAE4 Sn869; Calibrated: 2008-09-03
- Phantom: SAM 1800/1900 MHz; Type: SAM

Dipole 1900MHz Validation/Area Scan (61x61x1): Measurement grid: dx=15mm, dy=15mm
Maximum value of SAR (interpolated) = 4.56 mW/g

Dipole 1900MHz Validation/Zoom Scan (5x5x7)/Cube 0: Measurement grid: dx=8mm, dy=8mm, dz=5mm
Reference Value = 58.0 V/m; Power Drift = -0.063 dB
Peak SAR (extrapolated) = 6.59 W/kg
SAR(1 g) = 3.8 mW/g; SAR(10 g) = 1.97 mW/g
Maximum value of SAR (measured) = 4.21 mW/g

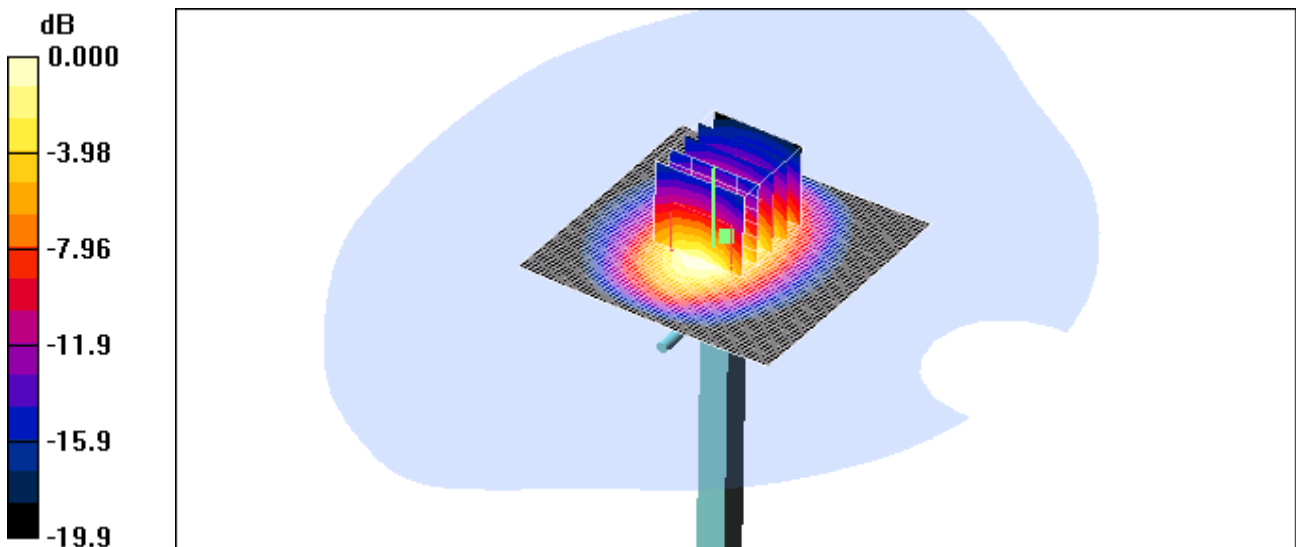

0 dB = 4.21mW/g

■ Dielectric Parameter (835 MHz Head)

Title QS100
SubTitle GSM850(Head)
Test Date Jul.12, 2009

Frequency	e'	e''
800000000	41.1604	18.7973
805000000	41.0917	18.7969
810000000	40.9977	18.7982
815000000	40.9423	18.7787
820000000	40.8505	18.7588
825000000	40.7926	18.7619
830000000	40.7344	18.7599
835000000	40.6555	18.7742
840000000	40.5593	18.7777
845000000	40.5195	18.7556
850000000	40.4640	18.7485
855000000	40.4337	18.7550
860000000	40.3388	18.7285
865000000	40.2934	18.7294
870000000	40.2507	18.7548
875000000	40.2077	18.7047
880000000	40.1275	18.7158
885000000	40.0992	18.6773
890000000	40.0171	18.6397
895000000	39.9810	18.6389
900000000	39.9106	18.6186

■ Dielectric Parameter (835 MHz Body)

Title QS100
SubTitle GSM850(Body)
Test Date Jul.12, 2009

Frequency	e'	e''
800000000	54.1473	21.4717
805000000	54.1506	21.4670
810000000	54.0943	21.4832
815000000	54.0357	21.4889
820000000	53.9964	21.4822
825000000	53.9195	21.4612
830000000	53.9144	21.4812
835000000	53.8743	21.4030
840000000	53.8427	21.3610
845000000	53.8102	21.3743
850000000	53.7102	21.3199
855000000	53.7054	21.3285
860000000	53.5929	21.3069
865000000	53.5339	21.3090
870000000	53.4542	21.2815
875000000	53.3245	21.2734
880000000	53.2868	21.2098
885000000	53.2038	21.1641
890000000	53.1187	21.1514
895000000	53.0423	21.1306
900000000	53.0152	21.0860

■ Dielectric Parameter (1900 MHz Head)

Title QS100
SubTitle GSM1900(Head)
Test Date Jul.13, 2009

Frequency	e'	e''
1800000000	39.3766	12.9994
1810000000	39.2992	12.9815
1820000000	39.2424	13.0206
1830000000	39.1951	13.0631
1840000000	39.1947	13.1069
1850000000	39.1151	13.0828
1860000000	39.0878	13.0984
1870000000	39.0788	13.1561
1880000000	38.9995	13.1892
1890000000	38.9735	13.2247
1900000000	38.9291	13.3043
1910000000	38.8647	13.3169
1920000000	38.8280	13.3388
1930000000	38.7656	13.3830
1940000000	38.7403	13.4008
1950000000	38.7250	13.4326
1960000000	38.6727	13.4504
1970000000	38.6264	13.4442
1980000000	38.5945	13.4811
1990000000	38.5623	13.5068
2000000000	38.5012	13.5486

■ Dielectric Parameter (1900 MHz Body)

Title QS100
SubTitle GSM1900(Body)
Test Date Jul.13, 2009

Frequency	e'	e''
1800000000	52.7767	13.8170
1810000000	52.7774	13.8798
1820000000	52.7645	13.9326
1830000000	52.6814	13.9852
1840000000	52.6657	14.0009
1850000000	52.5936	14.0487
1860000000	52.5187	14.0706
1870000000	52.4340	14.1236
1880000000	52.3631	14.1937
1890000000	52.2884	14.2248
1900000000	52.2564	14.2970
1910000000	52.2156	14.3847
1920000000	52.1871	14.4831
1930000000	52.1862	14.5384
1940000000	52.1356	14.5571
1950000000	52.1250	14.5857
1960000000	52.0557	14.6228
1970000000	51.9804	14.6589
1980000000	51.9420	14.6788
1990000000	51.8565	14.7116
2000000000	51.8017	14.7483

Attachment 3. – Probe Calibration Data

**Calibration Laboratory of
Schmid & Partner
Engineering AG**
Zeughausstrasse 43, 8004 Zurich, Switzerland



S Schweizerischer Kalibrierdienst
S Service suisse d'étalonnage
S Servizio svizzero di taratura
S Swiss Calibration Service

Accredited by the Swiss Accreditation Service (SAS)
The Swiss Accreditation Service is one of the signatories to the EA
Multilateral Agreement for the recognition of calibration certificates

Accreditation No.: **SCS 108**

Client **HCT (Dymstec)**

Certificate No: **ET3-1609_Mar09**

CALIBRATION CERTIFICATE

Object: **ET3DV6 - SN:1609**

Calibration procedure(s): **QA CAL-01.v6, QA CAL-12.v5 and QA CAL-23.v3
Calibration procedure for dosimetric E-field probes**

Calibration date: **March 17, 2009**

Condition of the calibrated item: **In Tolerance**

This calibration certificate documents the traceability to national standards, which realize the physical units of measurements (SI).
The measurements and the uncertainties with confidence probability are given on the following pages and are part of the certificate.

All calibrations have been conducted in the closed laboratory facility: environment temperature (22 ± 3)*°C and humidity < 70%.

Calibration Equipment used (M&TE critical for calibration)

Primary Standards	ID #	Cal Date (Certificate No.)	Scheduled Calibration
Power meter E4419B	GB41293874	1-Apr-08 (No. 217-00788)	Apr-09
Power sensor E4412A	MY41495277	1-Apr-08 (No. 217-00788)	Apr-09
Power sensor E4412A	MY41498087	1-Apr-08 (No. 217-00788)	Apr-09
Reference 3 dB Attenuator	SN: S5054 (3c)	1-Jul-08 (No. 217-00865)	Jul-09
Reference 20 dB Attenuator	SN: S5086 (20b)	31-Mar-08 (No. 217-00787)	Apr-09
Reference 30 dB Attenuator	SN: S5129 (30b)	1-Jul-08 (No. 217-00866)	Jul-09
Reference Probe ES3DV2	SN: 3013	2-Jan-09 (No. ES3-3013_Jan09)	Jan-10
DAE4	SN: 660	9-Sep-08 (No. DAE4-660_Sep08)	Sep-09
Secondary Standards	ID #	Check Date (in house)	Scheduled Check
RF generator HP 8848C	US3642U01700	4-Aug-99 (in house check Oct-07)	In house check: Oct-09
Network Analyzer HP 8753E	US37390585	18-Oct-01 (in house check Oct-08)	In house check: Oct-09

Calibrated by: **Marcel Fehr** (Name), **Laboratory Technician** (Function), *[Signature]* (Signature)

Approved by: **Katja Pokovic** (Name), **Technical Manager** (Function), *[Signature]* (Signature)

Issued: March 17, 2009

This calibration certificate shall not be reproduced except in full without written approval of the laboratory.

**Calibration Laboratory of
Schmid & Partner
Engineering AG**
Zeughausstrasse 43, 8004 Zurich, Switzerland



S Schweizerischer Kalibrierdienst
S Service suisse d'étalonnage
C Servizio svizzero di taratura
S Swiss Calibration Service

Accredited by the Swiss Accreditation Service (SAS)
The Swiss Accreditation Service is one of the signatories to the EA
Multilateral Agreement for the recognition of calibration certificates

Accreditation No.: **SCS 108**

Glossary:

TSL	tissue simulating liquid
NORM _{x,y,z}	sensitivity in free space
ConvF	sensitivity in TSL / NORM _{x,y,z}
DCP	diode compression point
Polarization φ	φ rotation around probe axis
Polarization ϑ	ϑ rotation around an axis that is in the plane normal to probe axis (at measurement center), i.e., $\vartheta = 0$ is normal to probe axis

Calibration is Performed According to the Following Standards:

- a) IEEE Std 1528-2003, "IEEE Recommended Practice for Determining the Peak Spatial-Averaged Specific Absorption Rate (SAR) in the Human Head from Wireless Communications Devices: Measurement Techniques", December 2003
- b) IEC 62209-1, "Procedure to measure the Specific Absorption Rate (SAR) for hand-held devices used in close proximity to the ear (frequency range of 300 MHz to 3 GHz)", February 2005

Methods Applied and Interpretation of Parameters:

- **NORM_{x,y,z}**: Assessed for E-field polarization $\vartheta = 0$ ($f \leq 900$ MHz in TEM-cell; $f > 1800$ MHz: R22 waveguide). NORM_{x,y,z} are only intermediate values, i.e., the uncertainties of NORM_{x,y,z} does not effect the E²-field uncertainty inside TSL (see below ConvF).
- **NORM(f)_{x,y,z} = NORM_{x,y,z} * frequency_response** (see Frequency Response Chart). This linearization is implemented in DASY4 software versions later than 4.2. The uncertainty of the frequency response is included in the stated uncertainty of ConvF.
- **DCP_{x,y,z}**: DCP are numerical linearization parameters assessed based on the data of power sweep (no uncertainty required). DCP does not depend on frequency nor media.
- **ConvF and Boundary Effect Parameters**: Assessed in flat phantom using E-field (or Temperature Transfer Standard for $f \leq 800$ MHz) and inside waveguide using analytical field distributions based on power measurements for $f > 800$ MHz. The same setups are used for assessment of the parameters applied for boundary compensation (alpha, depth) of which typical uncertainty values are given. These parameters are used in DASY4 software to improve probe accuracy close to the boundary. The sensitivity in TSL corresponds to NORM_{x,y,z} * ConvF whereby the uncertainty corresponds to that given for ConvF. A frequency dependent ConvF is used in DASY version 4.4 and higher which allows extending the validity from ± 50 MHz to ± 100 MHz.
- **Spherical isotropy (3D deviation from isotropy)**: in a field of low gradients realized using a flat phantom exposed by a patch antenna.
- **Sensor Offset**: The sensor offset corresponds to the offset of virtual measurement center from the probe tip (on probe axis). No tolerance required.

ET3DV6 SN:1609

March 17, 2009

Probe ET3DV6

SN:1609

Manufactured:	July 21, 2001
Last calibrated:	August 30, 2007
Recalibrated:	March 17, 2009

Calibrated for DASY Systems

(Note: non-compatible with DASY2 system!)

ET3DV6 SN:1609

March 17, 2009

DASY - Parameters of Probe: ET3DV6 SN:1609

Sensitivity in Free Space^A

Diode Compression^B

NormX	1.97 ± 10.1%	$\mu V/(V/m)^2$	DCP X	93 mV
NormY	1.87 ± 10.1%	$\mu V/(V/m)^2$	DCP Y	90 mV
NormZ	1.82 ± 10.1%	$\mu V/(V/m)^2$	DCP Z	93 mV

Sensitivity in Tissue Simulating Liquid (Conversion Factors)

Please see Page 8.

Boundary Effect

TSL **900 MHz** **Typical SAR gradient: 5 % per mm**

Sensor Center to Phantom Surface Distance		3.7 mm	4.7 mm
SAR _{be} [%]	Without Correction Algorithm	11.4	7.0
SAR _{be} [%]	With Correction Algorithm	0.9	0.5

TSL **1750 MHz** **Typical SAR gradient: 10 % per mm**

Sensor Center to Phantom Surface Distance		3.7 mm	4.7 mm
SAR _{be} [%]	Without Correction Algorithm	13.8	9.5
SAR _{be} [%]	With Correction Algorithm	0.9	0.6

Sensor Offset

Probe Tip to Sensor Center **2.7 mm**

The reported uncertainty of measurement is stated as the standard uncertainty of measurement multiplied by the coverage factor k=2, which for a normal distribution corresponds to a coverage probability of approximately 95%.

^A The uncertainties of NormX,Y,Z do not affect the E²-field uncertainty inside TSL (see Page 8).

^B Numerical linearization parameter: uncertainty not required

ET3DV6 SN:1609

March 17, 2009

Frequency Response of E-Field

(TEM-Cell:ifi110 EXX, Waveguide: R22)

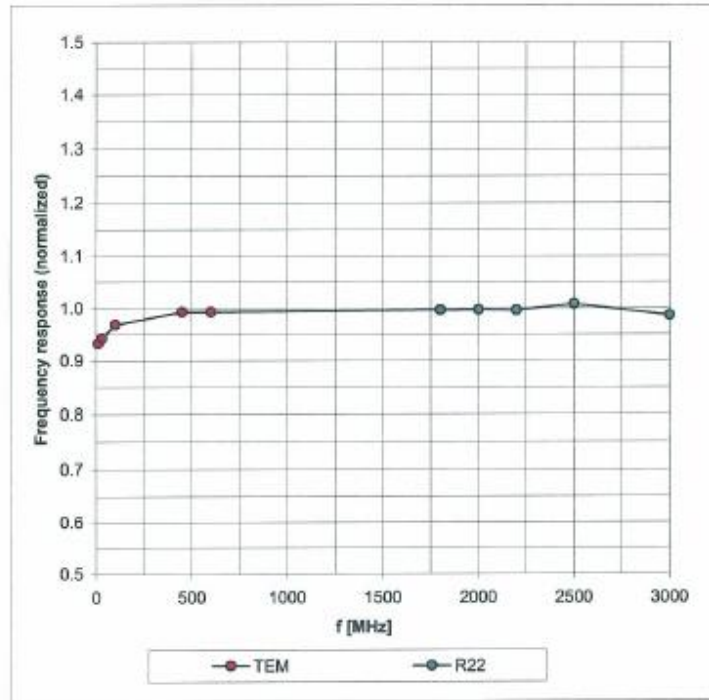

Uncertainty of Frequency Response of E-field: $\pm 6.3\%$ (k=2)

ET3DV6 SN:1609

March 17, 2009

Receiving Pattern (ϕ), $\theta = 0^\circ$

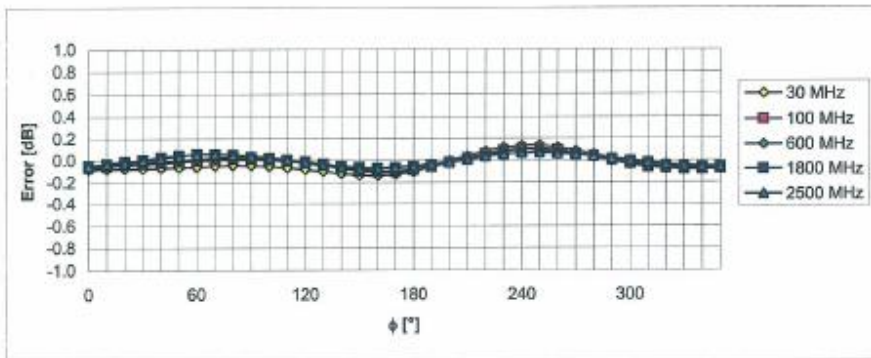
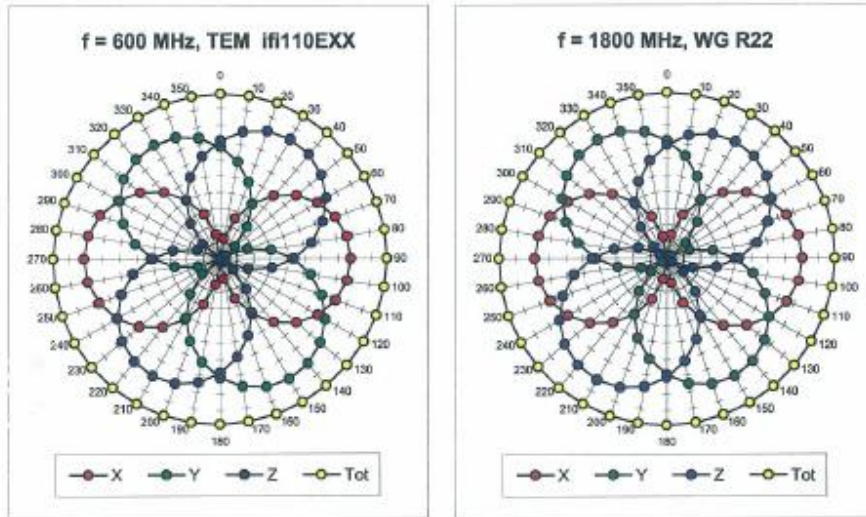

Uncertainty of Axial Isotropy Assessment: $\pm 0.5\%$ ($k=2$)

ET3DV6 SN:1609

March 17, 2009

Dynamic Range f(SAR_{head})
(Waveguide R22, f = 1800 MHz)

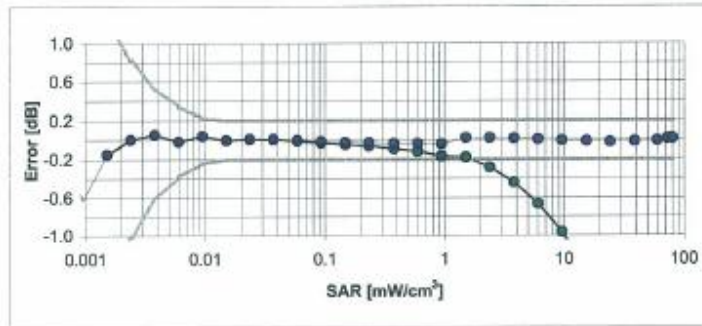
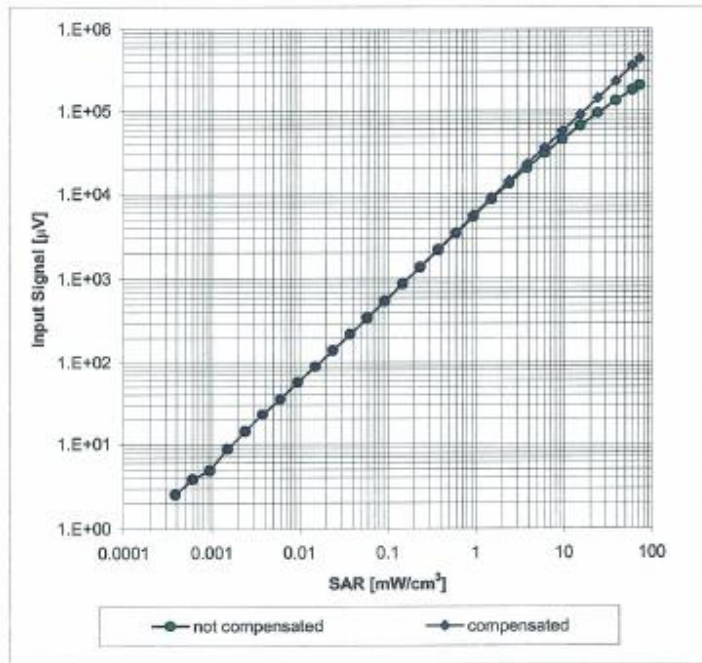

Uncertainty of Linearity Assessment: ± 0.6% (k=2)

ET3DV6 SN:1609

March 17, 2009

Conversion Factor Assessment

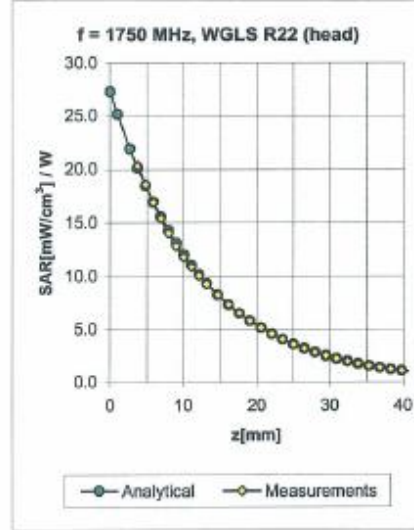
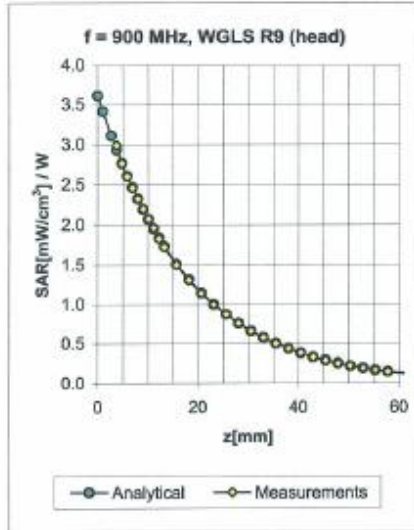

f [MHz]	Validity [MHz] ^c	TSL	Permittivity	Conductivity	Alpha	Depth	ConvF Uncertainty
450	± 50 / ± 100	Head	43.5 ± 5%	0.87 ± 5%	0.38	1.91	6.91 ± 13.3% (k=2)
835	± 50 / ± 100	Head	41.5 ± 5%	0.90 ± 5%	0.25	2.80	6.25 ± 11.0% (k=2)
900	± 50 / ± 100	Head	41.5 ± 5%	0.97 ± 5%	0.25	2.80	6.11 ± 11.0% (k=2)
1750	± 50 / ± 100	Head	40.1 ± 5%	1.37 ± 5%	0.39	3.57	5.39 ± 11.0% (k=2)
1900	± 50 / ± 100	Head	40.0 ± 5%	1.40 ± 5%	0.50	2.75	5.12 ± 11.0% (k=2)
1950	± 50 / ± 100	Head	40.0 ± 5%	1.40 ± 5%	0.55	2.52	5.01 ± 11.0% (k=2)
2450	± 50 / ± 100	Head	39.2 ± 5%	1.80 ± 5%	0.99	1.76	4.54 ± 11.0% (k=2)
450	± 50 / ± 100	Body	56.7 ± 5%	0.94 ± 5%	0.30	1.92	7.48 ± 13.3% (k=2)
835	± 50 / ± 100	Body	55.2 ± 5%	0.97 ± 5%	0.25	2.85	6.08 ± 11.0% (k=2)
1750	± 50 / ± 100	Body	53.4 ± 5%	1.49 ± 5%	0.77	3.05	4.89 ± 11.0% (k=2)
1900	± 50 / ± 100	Body	53.3 ± 5%	1.52 ± 5%	0.99	2.60	4.61 ± 11.0% (k=2)
2450	± 50 / ± 100	Body	52.7 ± 5%	1.95 ± 5%	0.99	1.78	4.00 ± 11.0% (k=2)

^c The validity of ± 100 MHz only applies for DASY v4.4 and higher (see Page 2). The uncertainty is the RSS of the ConvF uncertainty at calibration frequency and the uncertainty for the indicated frequency band.

ET3DV6 SN:1609

March 17, 2009

Deviation from Isotropy in HSL

Error (ϕ, θ), $f = 900$ MHz

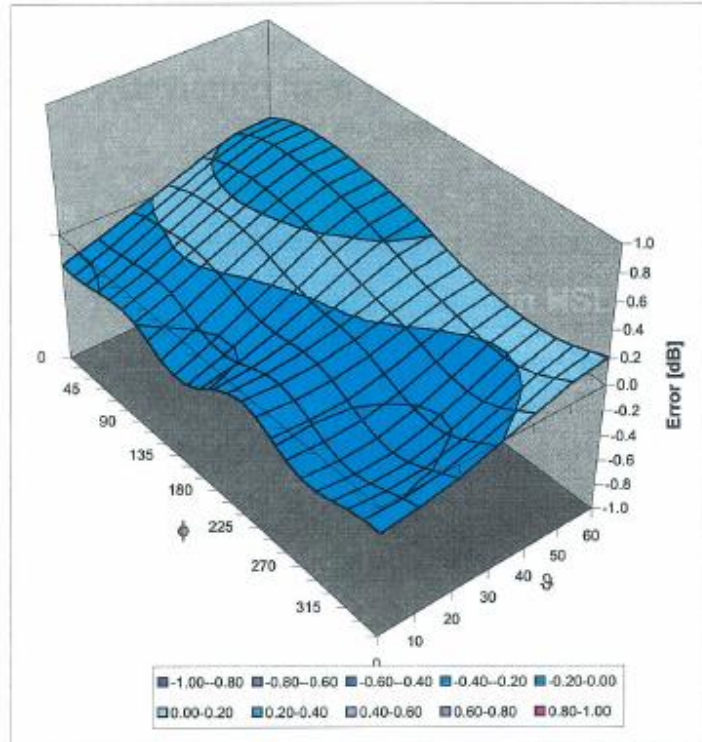

Uncertainty of Spherical Isotropy Assessment: $\pm 2.6\%$ ($k=2$)

Attachment 4. – Dipole Calibration Data

**Calibration Laboratory of
Schmid & Partner
Engineering AG**
Zeughausstrasse 43, 8004 Zurich, Switzerland



S Schweizerischer Kalibrierdienst
C Service suisse d'étalonnage
S Servizio svizzero di taratura
S Swiss Calibration Service

Accredited by the Swiss Accreditation Service (SAS)
The Swiss Accreditation Service is one of the signatories to the EA
Multilateral Agreement for the recognition of calibration certificates

Accreditation No.: **SCS 108**

Client **HTC (Dymstec)**

Certificate No: **D835V2-441_May09**

CALIBRATION CERTIFICATE			
Object	D835V2 - SN: 441		
Calibration procedure(s)	QA CAL-05.v7 Calibration procedure for dipole validation kits		
Calibration date:	May 25, 2009		
Condition of the calibrated item	In Tolerance		
This calibration certificate documents the traceability to national standards, which realize the physical units of measurements (SI). The measurements and the uncertainties with confidence probability are given on the following pages and are part of the certificate.			
All calibrations have been conducted in the closed laboratory facility: environment temperature (22 ± 3)°C and humidity < 70%.			
Calibration Equipment used (M&TE critical for calibration)			
Primary Standards	ID #	Cal Date (Certificate No.)	Scheduled Calibration
Power meter EPM-442A	GB37480704	08-Oct-08 (No. 217-00898)	Oct-09
Power sensor HP 8481A	US37292783	08-Oct-08 (No. 217-00898)	Oct-09
Reference 20 dB Attenuator	SN: 5086 (20g)	31-Mar-09 (No. 217-01025)	Mar-10
Type-N mismatch combination	SN: 5047.2 / 06327	31-Mar-09 (No. 217-01029)	Mar-10
Reference Probe ES3DV2	SN: 3025	30-Apr-09 (No. ES3-3025_Apr09)	Apr-10
DAE4	SN: 601	07-Mar-09 (No. DAE4-601_Mar09)	Mar-10
Secondary Standards	ID #	Check Date (in house)	Scheduled Check
Power sensor HP 8481A	MY41092317	18-Oct-02 (in house check Oct-07)	In house check: Oct-09
RF generator R&S SMT-06	100005	4-Aug-99 (in house check Oct-07)	In house check: Oct-09
Network Analyzer HP 8753E	US37390585 S4206	18-Oct-01 (in house check Oct-08)	In house check: Oct-09
Calibrated by:	Name Jeton Kastrati	Function Laboratory Technician	Signature
Approved by:	Name Katja Pokovic	Function Technical Manager	Signature
			Issued: May 25, 2009
This calibration certificate shall not be reproduced except in full without written approval of the laboratory.			

Calibration Laboratory of
Schmid & Partner
Engineering AG
Zeughausstrasse 43, 8004 Zurich, Switzerland



S Schweizerischer Kalibrierdienst
C Service suisse d'étalonnage
S Servizio svizzero di taratura
S Swiss Calibration Service

Accredited by the Swiss Accreditation Service (SAS)
The Swiss Accreditation Service is one of the signatories to the EA
Multilateral Agreement for the recognition of calibration certificates

Accreditation No.: **SCS 108**

Glossary:

TSL	tissue simulating liquid
ConvF	sensitivity in TSL / NORM x,y,z
N/A	not applicable or not measured

Calibration is Performed According to the Following Standards:

- IEEE Std 1528-2003, "IEEE Recommended Practice for Determining the Peak Spatial-Averaged Specific Absorption Rate (SAR) in the Human Head from Wireless Communications Devices: Measurement Techniques", December 2003
- IEC 62209-1, "Procedure to measure the Specific Absorption Rate (SAR) for hand-held devices used in close proximity to the ear (frequency range of 300 MHz to 3 GHz)", February 2005
- Federal Communications Commission Office of Engineering & Technology (FCC OET), "Evaluating Compliance with FCC Guidelines for Human Exposure to Radiofrequency Electromagnetic Fields; Additional Information for Evaluating Compliance of Mobile and Portable Devices with FCC Limits for Human Exposure to Radiofrequency Emissions", Supplement C (Edition 01-01) to Bulletin 65

Additional Documentation:

- DASY4/5 System Handbook

Methods Applied and Interpretation of Parameters:

- Measurement Conditions:** Further details are available from the Validation Report at the end of the certificate. All figures stated in the certificate are valid at the frequency indicated.
- Antenna Parameters with TSL:** The dipole is mounted with the spacer to position its feed point exactly below the center marking of the flat phantom section, with the arms oriented parallel to the body axis.
- Feed Point Impedance and Return Loss:** These parameters are measured with the dipole positioned under the liquid filled phantom. The impedance stated is transformed from the measurement at the SMA connector to the feed point. The Return Loss ensures low reflected power. No uncertainty required.
- Electrical Delay:** One-way delay between the SMA connector and the antenna feed point. No uncertainty required.
- SAR measured:** SAR measured at the stated antenna input power.
- SAR normalized:** SAR as measured, normalized to an input power of 1 W at the antenna connector.
- SAR for nominal TSL parameters:** The measured TSL parameters are used to calculate the nominal SAR result.

Measurement Conditions

DASY system configuration, as far as not given on page 1.

DASY Version	DASY5	V5.0
Extrapolation	Advanced Extrapolation	
Phantom	Modular Flat Phantom V4.9	
Distance Dipole Center - TSL	15 mm	with Spacer
Zoom Scan Resolution	dx, dy, dz = 5 mm	
Frequency	835 MHz \pm 1 MHz	

Head TSL parameters

The following parameters and calculations were applied.

	Temperature	Permittivity	Conductivity
Nominal Head TSL parameters	22.0 °C	41.5	0.90 mho/m
Measured Head TSL parameters	(22.0 \pm 0.2) °C	40.8 \pm 6 %	0.89 mho/m \pm 6 %
Head TSL temperature during test	(21.6 \pm 0.2) °C	----	----

SAR result with Head TSL

SAR averaged over 1 cm ³ (1 g) of Head TSL	Condition	
SAR measured	250 mW input power	2.38 mW / g
SAR normalized	normalized to 1W	9.52 mW / g
SAR for nominal Head TSL parameters ¹	normalized to 1W	9.56 mW /g \pm 17.0 % (k=2)

SAR averaged over 10 cm ³ (10 g) of Head TSL	condition	
SAR measured	250 mW input power	1.56 mW / g
SAR normalized	normalized to 1W	6.24 mW / g
SAR for nominal Head TSL parameters ¹	normalized to 1W	6.26 mW /g \pm 16.5 % (k=2)

¹ Correction to nominal TSL parameters according to d), chapter "SAR Sensitivities"

Appendix**Antenna Parameters with Head TSL**

Impedance, transformed to feed point	50.3 Ω - 7.4 j Ω
Return Loss	- 22.7 dB

General Antenna Parameters and Design

Electrical Delay (one direction)	1.393 ns
----------------------------------	----------

After long term use with 100W radiated power, only a slight warming of the dipole near the feedpoint can be measured.

The dipole is made of standard semirigid coaxial cable. The center conductor of the feeding line is directly connected to the second arm of the dipole. The antenna is therefore short-circuited for DC-signals.

No excessive force must be applied to the dipole arms, because they might bend or the soldered connections near the feedpoint may be damaged.

Additional EUT Data

Manufactured by	SPEAG
Manufactured on	March 09, 2001

DASY5 Validation Report for Head TSL

Date/Time: 25.05.2009 09:55:22

Test Laboratory: SPEAG, Zurich, Switzerland

DUT: Dipole 835 MHz; Type: D835V2; Serial: D835V2 - SN:441

Communication System: CW-835; Frequency: 835 MHz; Duty Cycle: 1:1

Medium: HSL 900 MHz

Medium parameters used: $f = 835$ MHz; $\sigma = 0.89$ mho/m; $\epsilon_r = 40.7$; $\rho = 1000$ kg/m³

Phantom section: Flat Section

Measurement Standard: DASY5 (IEEE/IEC)

DASY5 Configuration:

- Probe: ES3DV2 - SN3025; ConvF(5.86, 5.86, 5.86); Calibrated: 30.04.2009
- Sensor-Surface: 3mm (Mechanical Surface Detection)
- Electronics: DAE4 Sn601; Calibrated: 07.03.2009
- Phantom: Flat Phantom 4.9L; Type: QD000P49AA; Serial: 1001
- Measurement SW: DASY5, V5.0 Build 120; SEMCAD X Version 13.4 Build 45

Pin=250mW; dip=15mm/Zoom Scan (7x7x7)/Cube 0: Measurement grid: dx=5mm, dy=5mm, dz=5mm

Reference Value = 57.1 V/m; Power Drift = 0.0073 dB

Peak SAR (extrapolated) = 3.53 W/kg

SAR(1 g) = 2.38 mW/g; SAR(10 g) = 1.56 mW/g

Maximum value of SAR (measured) = 2.77 mW/g

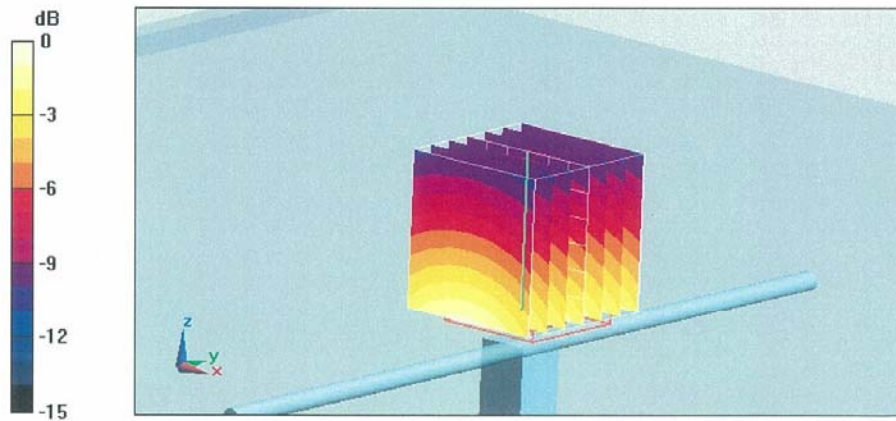

0 dB = 2.77mW/g

Impedance Measurement Plot for Head TSL

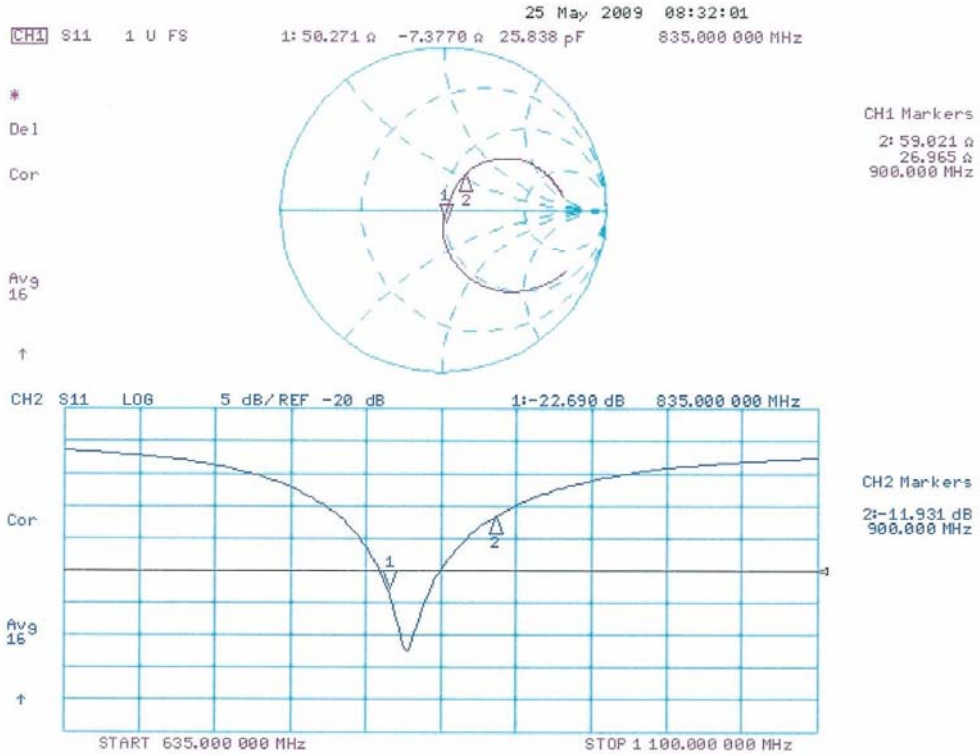

**Calibration Laboratory of
Schmid & Partner
Engineering AG**
Zeughausstrasse 43, 8004 Zurich, Switzerland



S Schweizerischer Kalibrierdienst
C Service suisse d'étalonnage
S Servizio svizzero di taratura
S Swiss Calibration Service

Accredited by the Swiss Accreditation Service (SAS)
The Swiss Accreditation Service is one of the signatories to the EA
Multilateral Agreement for the recognition of calibration certificates

Accreditation No.: **SCS 108**

Client **H-CT (Dymstec)**

Certificate No: **D1900V2-5d032-Jul08**

CALIBRATION CERTIFICATE

Object **D1900V2 - SN: 5d032**

Calibration procedure(s) **QA CAL-05.v7
Calibration procedure for dipole validation kits**

Calibration date: **July 22, 2008**

Condition of the calibrated item **In Tolerance**

This calibration certificate documents the traceability to national standards, which realize the physical units of measurements (SI).
The measurements and the uncertainties with confidence probability are given on the following pages and are part of the certificate.

All calibrations have been conducted in the closed laboratory facility; environment temperature (22 ± 3)°C and humidity < 70%.

Calibration Equipment used (M&TE critical for calibration)

Primary Standards	ID #	Cal Date (Calibrated by, Certificate No.)	Scheduled Calibration
Power meter EPM-442A	GB37480704	04-Oct-07 (No. 217-00736)	Oct-08
Power sensor HP 8481A	US37292783	04-Oct-07 (No. 217-00736)	Oct-08
Reference 20 dB Attenuator	SN: 5086 (20g)	01-Jul-08 (No. 217-00864)	Jul-09
Type-N mismatch combination	SN: 5047.2 / 06327	01-Jul-08 (No. 217-00867)	Jul-09
Reference Probe ES3DV2	SN: 3025	28-Apr-08 (No. ES3-3025_Apr08)	Apr-09
DAE4	SN: 601	14-Mar-08 (No. DAE4-601_Mar08)	Mar-09

Secondary Standards	ID #	Check Date (in house)	Scheduled Check
Power sensor HP 8481A	MY41092317	18-Oct-02 (in house check Oct-07)	In house check: Oct-09
RF generator R&S SMT-06	100005	4-Aug-99 (in house check Oct-07)	In house check: Oct-09
Network Analyzer HP 8753E	US37390585 S4206	18-Oct-01 (in house check Oct-07)	In house check: Oct-08

	Name	Function	Signature
Calibrated by:	Jeton Kastrati	Laboratory Technician	
Approved by:	Katja Pokovic	Technical Manager	

Issued: July 22, 2008

This calibration certificate shall not be reproduced except in full without written approval of the laboratory.

Calibration Laboratory of
Schmid & Partner
Engineering AG
Zeughausstrasse 43, 8004 Zurich, Switzerland



S Schweizerischer Kalibrierdienst
C Service suisse d'étalonnage
S Servizio svizzero di taratura
S Swiss Calibration Service

Accredited by the Swiss Accreditation Service (SAS)
The Swiss Accreditation Service is one of the signatories to the EA
Multilateral Agreement for the recognition of calibration certificates

Accreditation No.: **SCS 108**

Glossary:

TSL tissue simulating liquid
ConvF sensitivity in TSL / NORM x,y,z
N/A not applicable or not measured

Calibration is Performed According to the Following Standards:

- a) IEEE Std 1528-2003, "IEEE Recommended Practice for Determining the Peak Spatial-Averaged Specific Absorption Rate (SAR) in the Human Head from Wireless Communications Devices: Measurement Techniques", December 2003
- b) CENELEC EN 50361, "Basic standard for the measurement of Specific Absorption Rate related to human exposure to electromagnetic fields from mobile phones (300 MHz - 3 GHz), July 2001
- c) Federal Communications Commission Office of Engineering & Technology (FCC OET), "Evaluating Compliance with FCC Guidelines for Human Exposure to Radiofrequency Electromagnetic Fields; Additional Information for Evaluating Compliance of Mobile and Portable Devices with FCC Limits for Human Exposure to Radiofrequency Emissions", Supplement C (Edition 01-01) to Bulletin 65

Additional Documentation:

- d) DASY4/5 System Handbook

Methods Applied and Interpretation of Parameters:

- *Measurement Conditions:* Further details are available from the Validation Report at the end of the certificate. All figures stated in the certificate are valid at the frequency indicated.
- *Antenna Parameters with TSL:* The dipole is mounted with the spacer to position its feed point exactly below the center marking of the flat phantom section, with the arms oriented parallel to the body axis.
- *Feed Point Impedance and Return Loss:* These parameters are measured with the dipole positioned under the liquid filled phantom. The impedance stated is transformed from the measurement at the SMA connector to the feed point. The Return Loss ensures low reflected power. No uncertainty required.
- *Electrical Delay:* One-way delay between the SMA connector and the antenna feed point. No uncertainty required.
- *SAR measured:* SAR measured at the stated antenna input power.
- *SAR normalized:* SAR as measured, normalized to an input power of 1 W at the antenna connector.
- *SAR for nominal TSL parameters:* The measured TSL parameters are used to calculate the nominal SAR result.

Measurement Conditions

DASY system configuration, as far as not given on page 1.

DASY Version	DASY4	V4.7
Extrapolation	Advanced Extrapolation	
Phantom	Modular Flat Phantom V5.0	
Distance Dipole Center - TSL	10 mm	with Spacer
Zoom Scan Resolution	dx, dy, dz = 5 mm	
Frequency	1900 MHz \pm 1 MHz	

Head TSL parameters

The following parameters and calculations were applied.

	Temperature	Permittivity	Conductivity
Nominal Head TSL parameters	22.0 °C	40.0	1.40 mho/m
Measured Head TSL parameters	(22.0 \pm 0.2) °C	38.8 \pm 6 %	1.47 mho/m \pm 6 %
Head TSL temperature during test	(22.0 \pm 0.2) °C	---	---

SAR result with Head TSL

SAR averaged over 1 cm³ (1 g) of Head TSL	condition	
SAR measured	250 mW input power	9.82 mW / g
SAR normalized	normalized to 1W	39.3 mW / g
SAR for nominal Head TSL parameters ¹	normalized to 1W	37.7 mW / g \pm 17.0 % (k=2)

SAR averaged over 10 cm³ (10 g) of Head TSL	Condition	
SAR measured	250 mW input power	5.05 mW / g
SAR normalized	normalized to 1W	20.2 mW / g
SAR for nominal Head TSL parameters ¹	normalized to 1W	19.7 mW / g \pm 16.5 % (k=2)

¹ Correction to nominal TSL parameters according to d), chapter "SAR Sensitivities"

Appendix**Antenna Parameters with Head TSL**

Impedance, transformed to feed point	53.5 Ω + 4.9 j Ω
Return Loss	- 24.8 dB

General Antenna Parameters and Design

Electrical Delay (one direction)	1.185 ns
----------------------------------	----------

After long term use with 100W radiated power, only a slight warming of the dipole near the feedpoint can be measured.

The dipole is made of standard semirigid coaxial cable. The center conductor of the feeding line is directly connected to the second arm of the dipole. The antenna is therefore short-circuited for DC-signals.

No excessive force must be applied to the dipole arms, because they might bend or the soldered connections near the feedpoint may be damaged.

Additional EUT Data

Manufactured by	SPEAG
Manufactured on	March 17, 2003

DASY4 Validation Report for Head TSL

Date/Time: 22.07.2008 10:06:43

Test Laboratory: SPEAG, Zurich, Switzerland

DUT: Dipole 1900 MHz; Type: D1900V2; Serial: D1900V2 - SN:5d032

Communication System: CW; Frequency: 1900 MHz; Duty Cycle: 1:1

Medium: HSL U10 BB;

Medium parameters used: $f = 1900$ MHz; $\sigma = 1.47$ mho/m; $\epsilon_r = 38.8$; $\rho = 1000$ kg/m³

Phantom section: Flat Section

Measurement Standard: DASY4 (High Precision Assessment)

DASY4 Configuration:

- Probe: ES3DV2 - SN3025; ConvF(4.9, 4.9, 4.9); Calibrated: 28.04.2008
- Sensor-Surface: 3.4mm (Mechanical Surface Detection)
- Electronics: DAE4 Sn601; Calibrated: 14.03.2008
- Phantom: Flat Phantom 5.0 (front); Type: QD000P50AA; ;
- Measurement SW: DASY4, V4.7 Build 71; Postprocessing SW: SEMCAD, V1.8 Build 184

Pin = 250 mW; dip = 10 mm, scan at 3.4mm/Zoom Scan (dist=3.4mm, probe 0deg)**(7x7x7)/Cube 0: Measurement grid: dx=5mm, dy=5mm, dz=5mm**

Reference Value = 92.2 V/m; Power Drift = 0.010 dB

Peak SAR (extrapolated) = 18.2 W/kg

SAR(1 g) = 9.82 mW/g; SAR(10 g) = 5.05 mW/g

Maximum value of SAR (measured) = 11.9 mW/g

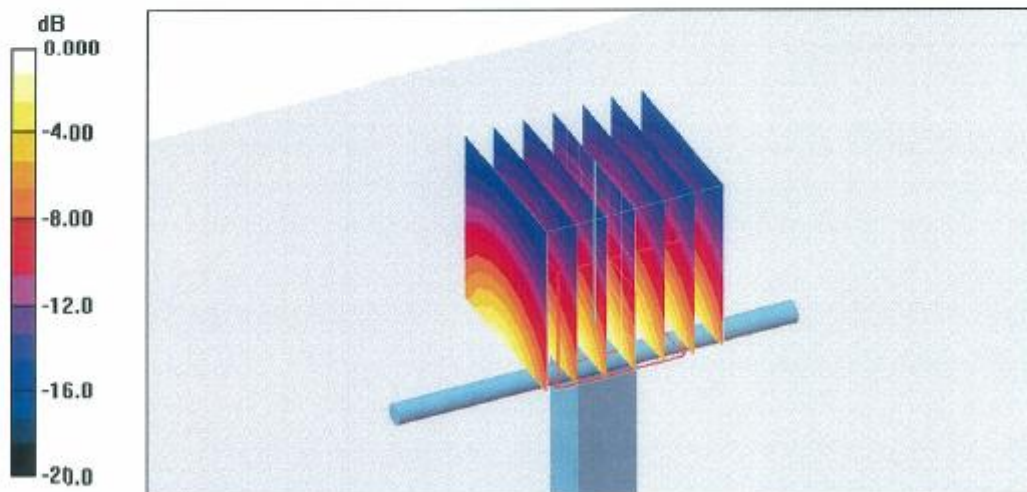

0 dB = 11.9mW/g

Impedance Measurement Plot for Head TSL

