

FCC Test Report

APPLICANT : Brightstar Corporation
EQUIPMENT : Mobile phone
BRAND NAME : Avvio / NOBLEX
MODEL NAME : Avvio SN53 / Noblex SN53
FCC ID : WVBSN53
STANDARD : FCC 47 CFR FCC Part 15 Subpart B
CLASSIFICATION : Certification

The product was received on Sep. 30, 2013 and testing was completed on Oct. 22, 2013. We, SPORTON INTERNATIONAL (SHENZHEN) INC., would like to declare that the tested sample has been evaluated in accordance with the procedures given in ANSI C63.4-2003 and shown to be compliant with the applicable technical standards.

The test results in this report apply exclusively to the tested model / sample. Without written approval of SPORTON INTERNATIONAL (SHENZHEN) INC., the test report shall not be reproduced except in full.

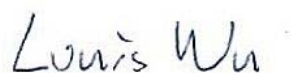

Reviewed by: Louis Wu / Manager

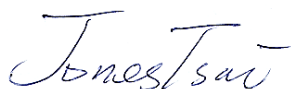

Approved by: Jones Tsai / Manager



SPORTON INTERNATIONAL (SHENZHEN) INC.

No. 3 Building, the third floor of south, Shahe River west, Fengzeyuan warehouse, Nanshan District, Shenzhen, Guangdong, P.R.C.



TABLE OF CONTENTS

REVISION HISTORY..... 3

SUMMARY OF TEST RESULT 4

1. GENERAL DESCRIPTION 5

 1.1. Applicant..... 5

 1.2. Manufacturer 5

 1.3. Feature of Equipment Under Test..... 5

 1.4. Product Specification of Equipment Under Test 6

 1.5. Modification of EUT 6

 1.6. Test Site 7

 1.7. Applied Standards 7

2. TEST CONFIGURATION OF EQUIPMENT UNDER TEST 8

 2.1. Test Mode 8

 2.2. Connection Diagram of Test System 10

 2.3. Support Unit used in test configuration and system..... 11

 2.4. EUT Operation Test Setup 11

3. TEST RESULT 12

 3.1. Test of AC Conducted Emission Measurement 12

 3.2. Test of Radiated Emission Measurement 19

4. LIST OF MEASURING EQUIPMENT 26

5. UNCERTAINTY OF EVALUATION 27

APPENDIX A. SETUP PHOTOGRAPHS



REVISION HISTORY

REPORT NO.	VERSION	DESCRIPTION	ISSUED DATE
FC393001	Rev. 01	Initial issue of report	Oct. 24, 2013

SUMMARY OF TEST RESULT

Report Section	FCC Rule	Description	Limit	Result	Remark
3.1	15.107	AC Conducted Emission	< 15.107 limits	PASS	Under limit 3.58 dB at 0.440 MHz
3.2	15.109	Radiated Emission	< 15.109 limits	PASS	Under limit 0.07 dB at 263.770 MHz for Quasi-Peak

1. General Description

1.1. Applicant

Brightstar Corporation

9725 NW 117th Ave., Miami, Florida, FL 33178, United States

1.2. Manufacturer

Skycom Telecommunications Co Limited

Room 604, East Block, Shengtang Building, Futian District, Shenzhen, China

1.3. Feature of Equipment Under Test

Product Feature	
Equipment	Mobile phone
Brand Name	Avvio / NOBLEX
Model Name	Avvio SN53 / Noblex SN53
FCC ID	WVBASN53
EUT supports Radios application	GSM/GPRS WLAN2.4GHz 802.11b/g/n HT20/HT40 Bluetooth v2.1 + EDR
HW Version	X508-MB-V0.5
SW Version	X508_7h_NOBLEX_V01_20130913_1410
EUT Stage	Identical Prototype

Remark: The above EUT's information was declared by manufacturer. Please refer to the specifications or user's manual for more detailed description.

1.4. Product Specification of Equipment Under Test

Product Specification subjective to this standard	
Tx Frequency	GSM850 : 824.2 MHz ~ 848.8 MHz GSM1900 : 1850.2 MHz ~ 1909.8MHz 802.11b/g/n: 2412 MHz ~ 2462 MHz Bluetooth: 2402 MHz ~ 2480 MHz
Rx Frequency	GSM850 : 869.2 MHz ~ 893.8 MHz GSM1900 : 1930.2 MHz ~ 1989.8 MHz 802.11b/g/n: 2412 MHz ~ 2462 MHz Bluetooth: 2402 MHz ~ 2480 MHz
Antenna Type	WWAN : PIFA Antenna WLAN : Monopole Antenna Bluetooth : Monopole Antenna
Type of Modulation	GSM: GMSK GPRS: GMSK 802.11b : DSSS (DBPSK / DQPSK / CCK) 802.11g/n : OFDM (BPSK / QPSK / 16QAM / 64QAM) Bluetooth v2.1 BR (1Mbps) : GFSK Bluetooth v2.1 EDR (2Mbps) : $\pi/4$ -DQPSK Bluetooth v2.1 EDR (3Mbps) : 8-DPSK

1.5. Modification of EUT

No modifications are made to the EUT during all test items.

1.6. Test Site

Test Site	SPORTON INTERNATIONAL (SHENZHEN) INC.		
Test Site Location	No. 3 Building, the third floor of south, Shahe River west, Fengzeyuan warehouse, Nanshan District, Shenzhen, Guangdong, P.R.C. TEL: +86-755- 3320-2398		
Test Site No.	Sporton Site No.		FCC Registration No.
	CO01-SZ	03CH01-SZ	831040

1.7. Applied Standards

According to the specifications of the manufacturer, the EUT must comply with the requirements of the following standards:

- ♦ FCC 47 CFR FCC Part 15 Subpart B
- ♦ ANSI C63.4-2003

Remark: All test items were verified and recorded according to the standards and without any deviation during the test.

2. Test Configuration of Equipment Under Test

2.1. Test Mode

The EUT has been associated with peripherals pursuant to ANSI C63.4-2003 and configuration operated in a manner tended to maximize its emission characteristics in a typical application.

Frequency range investigated: conduction (150 kHz to 30 MHz), radiation (30MHz to the 5th harmonic of the highest fundamental frequency or to 40 GHz, whichever is lower).

The following tables are showing the test modes as the worst cases and recorded in this report.

Item	EUT Configuration	Test Condition		
		EMI AC	EMI RE<1G	EMI RE≥1G
1.	Charging Mode (EUT with adapter)	☒	☒	☒
2.	Data application transferred mode (EUT with notebook)	☒	☒	☒

Abbreviations:

- EMI AC: AC conducted emissions
- EMI RE ≥ 1G: EUT radiated emissions ≥ 1GHz
- EMI RE < 1G: EUT radiated emissions < 1GHz

Test Items	EUT Configure Mode	Function Type
AC Conducted Emission	1/2	Mode 1: GSM850 Idle + Bluetooth Idle + WLAN Idle + Adapter + Earphone + Camera <Fig.1> Mode 2: GSM1900 Idle + Bluetooth Idle + WLAN Idle + Adapter + Earphone + MPEG4 <Fig.1> Mode 3: GSM1900 Idle + Bluetooth Idle + WLAN Idle + USB Cable (Data Link with Notebook) + Earphone <Fig.2>
Radiated Emissions < 1GHz	1/2	Mode 1: GSM850 Idle + Bluetooth Idle + WLAN Idle + Adapter + Earphone + Camera <Fig.1> Mode 2: GSM1900 Idle + Bluetooth Idle + WLAN Idle + Adapter + Earphone + MPEG4 <Fig.1> Mode 3: GSM1900 Idle + Bluetooth Idle + WLAN Idle + USB Cable (Data Link with Notebook) + Earphone <Fig.2>
Radiated Emissions ≥ 1GHz	1/2	Mode 1: GSM850 Idle + Bluetooth Idle + WLAN Idle + Adapter + Earphone + Camera <Fig.1> Mode 2: GSM1900 Idle + Bluetooth Idle + WLAN Idle + USB Cable (Data Link with Notebook) + Earphone <Fig.2>
Remark: <ol style="list-style-type: none"> The worst case of AC is mode 2; the test data of this mode is reported. And the USB Link mode of AC is mode 3; the test data of this mode is also reported. The worst case of RE < 1G is mode 1; the test data of this mode was reported. And the USB Link mode of RE is mode 3; the test data of this mode is also reported. Link with Notebook means data application transferred mode between EUT and Notebook. 		

2.2. Connection Diagram of Test System

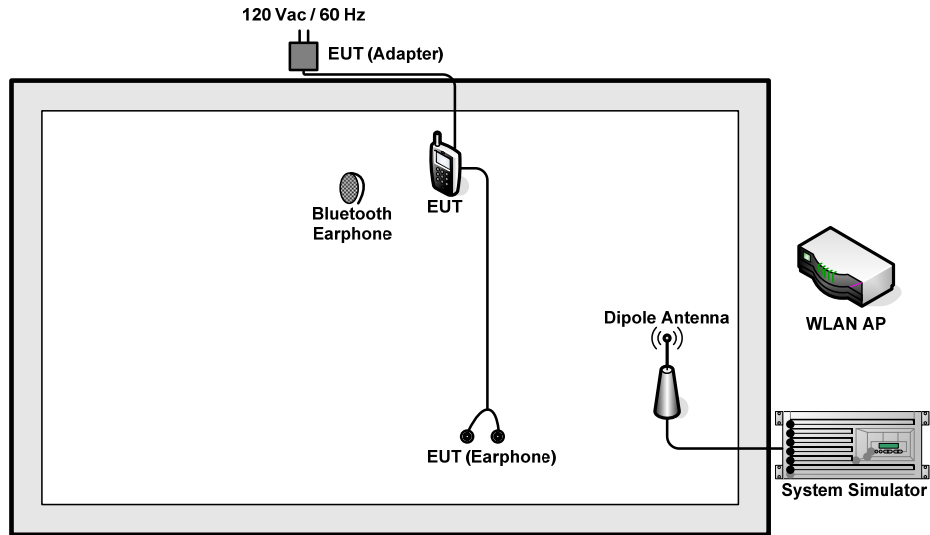

<Fig.1>

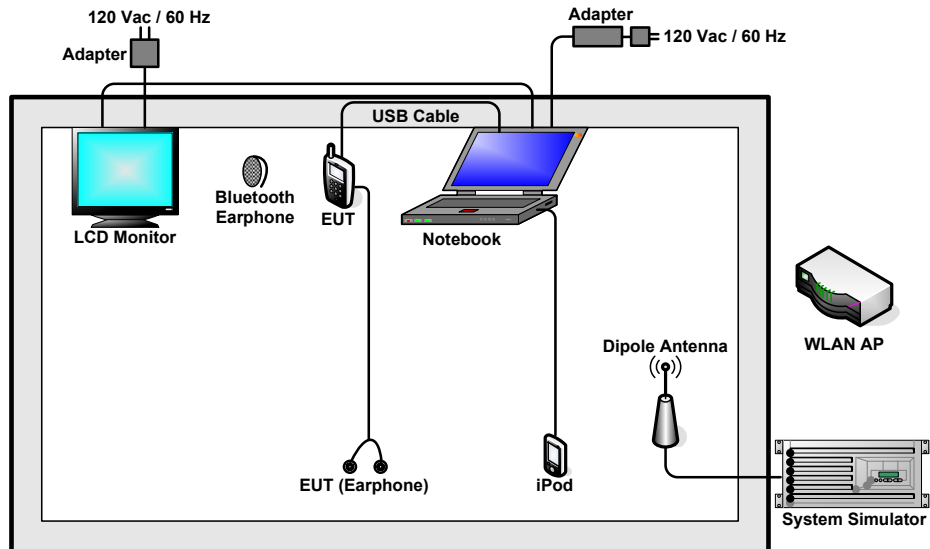

<Fig.2>

2.3. Support Unit used in test configuration and system

Item	Equipment	Trade Name	Model Name	FCC ID	Data Cable	Power Cord
1.	System Simulator	Agilent	E5515C	N/A	N/A	Unshielded, 1.8 m
2.	WLAN AP	ESD-dlink	DIR-612	N/A	N/A	Unshielded, 1.8 m
3.	WLAN AP	D-link	DIR-615	N/A	N/A	Unshielded, 1.8 m
4.	Bluetooth Earphone	Nokia	BH-108	N/A	N/A	N/A
5.	Notebook	DELL	P08S	FCC DoC	N/A	AC I/P: Unshielded, 1.8 m DC O/P: Shielded, 1.8 m
6.	LCD Monitor	DELL	IN1940MWB	FCC DoC	Shielded, 1.2 m	Unshielded, 1.8 m
7.	LCD Monitor	DELL	E1707FPt	FCC DoC	Shielded, 1.2 m	Unshielded, 1.8 m
8.	iPod	Apple	MC525 ZP/A	FCC DoC	Unshielded, 1.0 m	N/A

2.4. EUT Operation Test Setup

The EUT was in GSM idle mode during the testing. The EUT was synchronized to the BCCH, and was in continuous receiving mode by setting system simulator's paging reorganization.

At the same time, the EUT was attached to the Bluetooth earphone or WLAN AP, and the following programs installed in the EUT were programmed during the test.

1. Execute the program, "Winthrax" under WIN7 installed in notebook for files transfer with EUT via USB cable.
2. Execute "Windows Media Player" to play MPEG4 files.
3. Turn on camera to capture images.

3. Test Result

3.1. Test of AC Conducted Emission Measurement

3.1.1 Limits of AC Conducted Emission

For equipment that is designed to be connected to the public utility (AC) power line, the radio frequency voltage that is conducted back onto the AC power line on any frequency or frequencies within the band 150 kHz to 30 MHz shall not exceed the limits in the following table.

Frequency of emission (MHz)	Conducted limit (dBuV)	
	Quasi-peak	Average
0.15-0.5	66 to 56*	56 to 46*
0.5-5	56	46
5-30	60	50

*Decreases with the logarithm of the frequency.

3.1.2 Measuring Instruments

The measuring equipment is listed in the section 4 of this test report.

3.1.3 Test Procedure

1. The EUT was placed 0.4 meter from the conducting wall of the shielding room was kept at least 80 centimeters from any other grounded conducting surface.
2. Connect EUT to the power mains through a line impedance stabilization network (LISN).
3. All the support units are connecting to the other LISN.
4. The LISN provides 50 ohm coupling impedance for the measuring instrument.
5. The FCC states that a 50 ohm, 50 microhenry LISN should be used.
6. Both sides of AC line were checked for maximum conducted interference.
7. The frequency range from 150 kHz to 30 MHz was searched.
8. Set the test-receiver system to Peak Detect Function and specified bandwidth with Maximum Hold Mode.

3.1.4 Test Setup



3.1.5 Test Result of AC Conducted Emission

Test Mode :	Mode 2	Temperature :	23~24°C
Test Engineer :	Henry Chen	Relative Humidity :	49~50%
Test Voltage :	120Vac / 60Hz	Phase :	Line
Function Type :	GSM1900 Idle + Bluetooth Idle + WLAN Idle + Adapter + Earphone + MPEG4		

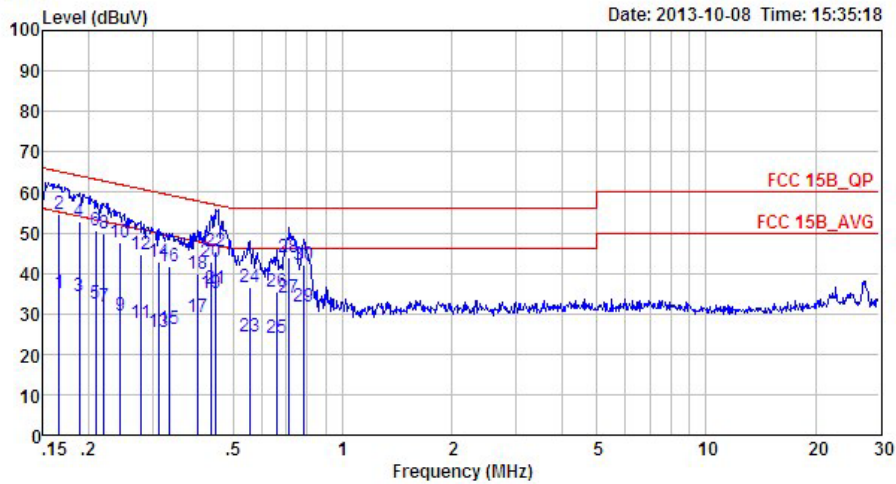

Site : CO01-SZ
 Condition: FCC 15B_QP LISN_L_20130328 LINE
 Project : (FC) 393001
 Mode : Mode 2

	Freq	Level	Over	Limit	Read	LISN	Cable	
	MHz	dBuV	Limit	Line	Level	Factor	Loss	Remark
			dB	dBuV	dBuV	dB	dB	
1	0.17	35.19	-19.97	55.16	24.80	0.06	10.33	Average
2 *	0.17	54.49	-10.67	65.16	44.10	0.06	10.33	QP
3	0.19	34.36	-19.75	54.11	24.00	0.07	10.29	Average
4	0.19	52.76	-11.35	64.11	42.40	0.07	10.29	QP
5	0.21	32.63	-20.60	53.23	22.30	0.07	10.26	Average
6	0.21	50.43	-12.80	63.23	40.10	0.07	10.26	QP
7	0.22	31.83	-20.96	52.79	21.50	0.08	10.25	Average
8	0.22	49.93	-12.86	62.79	39.60	0.08	10.25	QP
9	0.24	29.61	-22.34	51.95	19.30	0.09	10.22	Average
10	0.24	47.61	-14.34	61.95	37.30	0.09	10.22	QP
11	0.28	27.60	-23.30	50.90	17.29	0.10	10.21	Average
12	0.28	44.80	-16.10	60.90	34.49	0.10	10.21	QP
13	0.31	25.60	-24.33	49.93	15.30	0.10	10.20	Average
14	0.31	42.80	-17.13	59.93	32.50	0.10	10.20	QP
15	0.33	26.10	-23.30	49.40	15.80	0.11	10.19	Average
16	0.33	41.80	-17.60	59.40	31.50	0.11	10.19	QP
17	0.40	29.29	-18.61	47.90	19.00	0.12	10.17	Average
18	0.40	39.89	-18.01	57.90	29.60	0.12	10.17	QP
19	0.43	35.09	-12.11	47.20	24.80	0.13	10.16	Average
20	0.43	42.89	-14.31	57.20	32.60	0.13	10.16	QP
21	0.45	36.09	-10.80	46.89	25.80	0.13	10.16	Average
22	0.45	45.49	-11.40	56.89	35.20	0.13	10.16	QP
23	0.56	24.30	-21.70	46.00	14.00	0.15	10.15	Average
24	0.56	36.50	-19.50	56.00	26.20	0.15	10.15	QP



Test Mode :	Mode 2	Temperature :	23~24°C
Test Engineer :	Henry Chen	Relative Humidity :	49~50%
Test Voltage :	120Vac / 60Hz	Phase :	Line
Function Type :	GSM1900 Idle + Bluetooth Idle + WLAN Idle + Adapter + Earphone + MPEG4		

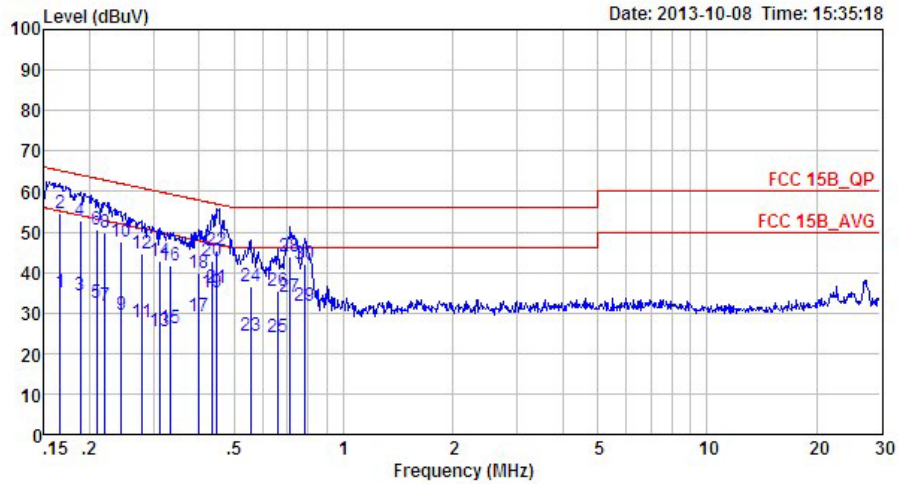

Site : CO01-SZ
 Condition: FCC 15B_QP LISN_L_20130328 LINE
 Project : (FC) 393001
 Mode : Mode 2

	Freq	Level	Over Limit	Limit Line	Read Level	LISN Factor	Cable Loss	Remark
	MHz	dBuV	dB	dBuV	dBuV	dB	dB	
25	0.66	23.91	-22.09	46.00	13.60	0.16	10.15	Average
26	0.66	35.61	-20.39	56.00	25.30	0.16	10.15	QP
27	0.71	33.81	-12.19	46.00	23.50	0.16	10.15	Average
28	0.71	43.81	-12.19	56.00	33.50	0.16	10.15	QP
29	0.78	31.82	-14.18	46.00	21.50	0.17	10.15	Average
30	0.78	42.12	-13.88	56.00	31.80	0.17	10.15	QP



Test Mode :	Mode 2	Temperature :	23~24°C
Test Engineer :	Henry Chen	Relative Humidity :	49~50%
Test Voltage :	120Vac / 60Hz	Phase :	Neutral
Function Type :	GSM1900 Idle + Bluetooth Idle + WLAN Idle + Adapter + Earphone + MPEG4		

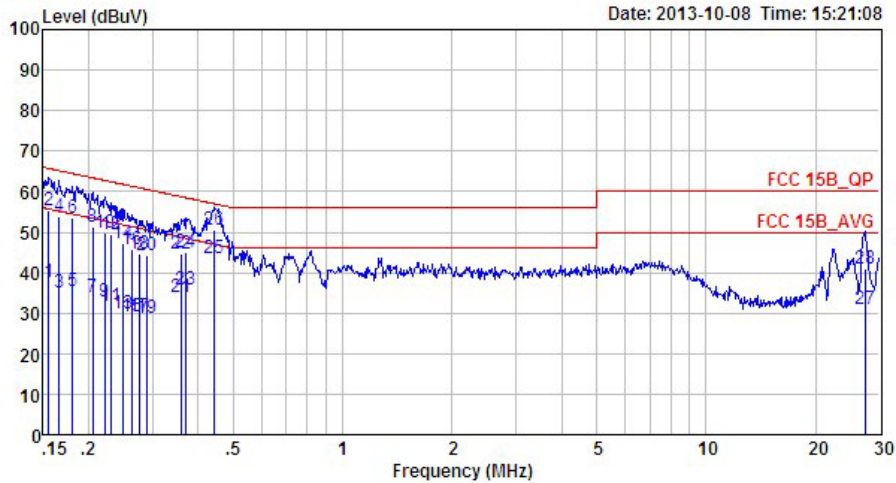

Site : CO01-SZ
 Condition: FCC 15B_QP LISN_N_20130328 NEUTRAL
 Project : (FC) 393001

	Freq	Level	Over Limit	Limit Line	Read Level	LISN Factor	Cable Loss	Remark
	MHz	dBuV	dB	dBuV	dBuV	dB	dB	
1	0.16	37.59	-18.10	55.69	27.20	0.04	10.35	Average
2	0.16	55.49	-10.20	65.69	45.10	0.04	10.35	QP
3	0.17	35.17	-19.99	55.16	24.80	0.04	10.33	Average
4	0.17	53.97	-11.19	65.16	43.60	0.04	10.33	QP
5	0.18	35.34	-19.12	54.46	25.00	0.04	10.30	Average
6	0.18	53.34	-11.12	64.46	43.00	0.04	10.30	QP
7	0.21	34.00	-19.40	53.40	23.70	0.04	10.26	Average
8	0.21	51.30	-12.10	63.40	41.00	0.04	10.26	QP
9	0.22	32.69	-20.05	52.74	22.40	0.04	10.25	Average
10	0.22	49.99	-12.75	62.74	39.70	0.04	10.25	QP
11	0.23	31.78	-20.66	52.44	21.50	0.04	10.24	Average
12	0.23	49.28	-13.16	62.44	39.00	0.04	10.24	QP
13	0.25	29.76	-22.02	51.78	19.50	0.04	10.22	Average
14	0.25	47.36	-14.42	61.78	37.10	0.04	10.22	QP
15	0.26	29.25	-22.04	51.29	19.00	0.04	10.21	Average
16	0.26	45.85	-15.44	61.29	35.60	0.04	10.21	QP
17	0.28	29.05	-21.89	50.94	18.80	0.04	10.21	Average
18	0.28	44.65	-16.29	60.94	34.40	0.04	10.21	QP
19	0.29	28.94	-21.60	50.54	18.70	0.04	10.20	Average
20	0.29	44.24	-16.30	60.54	34.00	0.04	10.20	QP
21	0.36	33.92	-14.82	48.74	23.70	0.04	10.18	Average
22	0.36	44.82	-13.92	58.74	34.60	0.04	10.18	QP
23	0.37	35.62	-12.85	48.47	25.40	0.04	10.18	Average
24	0.37	44.92	-13.55	58.47	34.70	0.04	10.18	QP
25 *	0.44	43.40	-3.58	46.98	33.20	0.04	10.16	Average
26	0.44	50.60	-6.38	56.98	40.40	0.04	10.16	QP
27	27.42	30.98	-19.02	50.00	19.20	1.21	10.57	Average
28	27.42	40.98	-19.02	60.00	29.20	1.21	10.57	QP



Test Mode :	Mode 3	Temperature :	23~24°C
Test Engineer :	Henry Chen	Relative Humidity :	49~50%
Test Voltage :	120Vac / 60Hz	Phase :	Line
Function Type :	GSM1900 Idle + Bluetooth Idle + WLAN Idle + USB Cable (Data Link with Notebook) + Earphone		

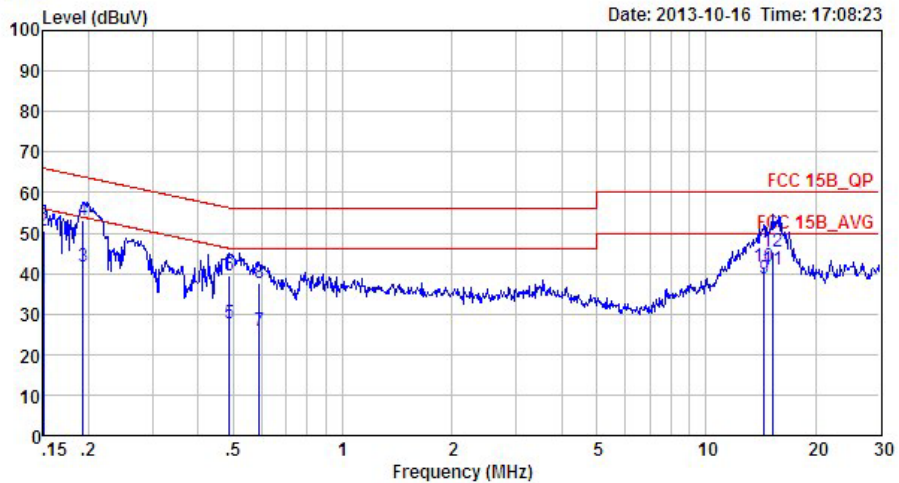

Site : CO01-SZ
 Condition: FCC 15B_QP LISN_L_20130328 LINE
 Project : (FC) 393001
 Mode : Mode 3

	Freq	Level	Over	Limit	Read	LISN	Cable	
	MHz	dBuV	Limit	Line	Level	Factor	Loss	Remark
			dB	dBuV	dBuV	dB	dB	
1	0.15	36.22	-19.78	56.00	25.80	0.06	10.36	Average
2	0.15	50.42	-15.58	66.00	40.00	0.06	10.36	QP
3	0.19	41.85	-12.04	53.89	31.50	0.07	10.28	Average
4	0.19	53.05	-10.84	63.89	42.70	0.07	10.28	QP
5	0.49	27.50	-18.69	46.19	17.20	0.14	10.16	Average
6	0.49	39.60	-16.59	56.19	29.30	0.14	10.16	QP
7	0.59	25.90	-20.10	46.00	15.60	0.15	10.15	Average
8	0.59	37.60	-18.40	56.00	27.30	0.15	10.15	QP
9	14.44	38.60	-11.40	50.00	27.29	0.89	10.42	Average
10	14.44	41.60	-18.40	60.00	30.29	0.89	10.42	QP
11 *	15.23	41.05	-8.95	50.00	29.70	0.92	10.43	Average
12	15.23	45.35	-14.65	60.00	34.00	0.92	10.43	QP



Test Mode :	Mode 3	Temperature :	23~24°C
Test Engineer :	Henry Chen	Relative Humidity :	49~50%
Test Voltage :	120Vac / 60Hz	Phase :	Neutral
Function Type :	GSM1900 Idle + Bluetooth Idle + WLAN Idle + USB Cable (Data Link with Notebook) + Earphone		

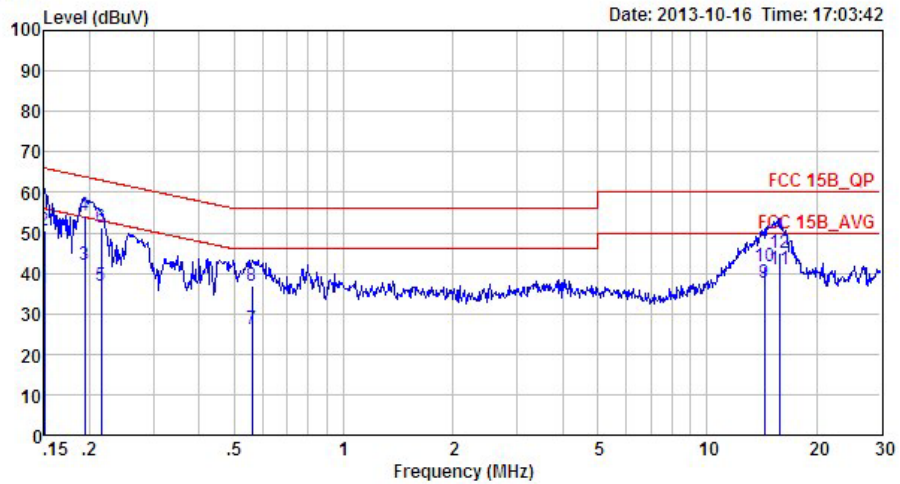

Site : CO01-SZ
 Condition: FCC 15B_QP LISN_N_20130328 NEUTRAL
 Project : (FC) 393001
 Mode : Mode 3

	Freq	Level	Over Limit	Limit Line	Read Level	LISN Factor	Cable Loss	Remark
	MHz	dBuV	dB	dBuV	dBuV	dB	dB	
1	0.15	36.00	-20.00	56.00	25.60	0.04	10.36	Average
2	0.15	50.40	-15.60	66.00	40.00	0.04	10.36	QP
3	0.19	41.92	-11.92	53.84	31.60	0.04	10.28	Average
4	0.19	54.32	-9.52	63.84	44.00	0.04	10.28	QP
5	0.22	36.99	-16.02	53.01	26.70	0.04	10.25	Average
6	0.22	51.29	-11.72	63.01	41.00	0.04	10.25	QP
7	0.56	26.19	-19.81	46.00	16.00	0.04	10.15	Average
8	0.56	36.79	-19.21	56.00	26.60	0.04	10.15	QP
9	14.36	37.61	-12.39	50.00	26.71	0.49	10.41	Average
10	14.36	41.71	-18.29	60.00	30.81	0.49	10.41	QP
11 *	15.89	41.03	-8.97	50.00	30.00	0.58	10.45	Average
12	15.89	45.13	-14.87	60.00	34.10	0.58	10.45	QP

3.2. Test of Radiated Emission Measurement

3.2.1. Limit of Radiated Emission

The emissions from an unintentional radiator shall not exceed the field strength levels specified in the following table:

Frequency (MHz)	Field Strength (microvolts/meter)	Measurement Distance (meters)
30 – 88	100	3
88 – 216	150	3
216 - 960	200	3
Above 960	500	3

3.2.2. Measuring Instruments

The measuring equipment is listed in the section 4 of this test report.

3.2.3. Test Procedures

1. The EUT was placed on a turntable with 0.8 meter above ground.
2. The EUT was set 3 meters from the interference receiving antenna, which was mounted on the top of a variable height antenna tower.
3. The table was rotated 360 degrees to determine the position of the highest radiation.
4. The antenna is a Bi-Log antenna and its height is adjusted between one to four meters above ground to find the maximum value of the field strength for both horizontal polarization and vertical polarization of the antenna.
5. For each suspected emission, the EUT was arranged to its worst case and then tune the antenna tower (from 1 m to 4 m) and turntable (from 0 degree to 360 degrees) to find the maximum reading.
6. Set the test-receiver system to Peak Detect Function and specified bandwidth with Maximum Hold Mode.
7. If the emission level of the EUT in peak mode was 3 dB lower than the limit specified, peak values of EUT will be reported. Otherwise, the emission will be repeated by using the quasi-peak method and reported.
8. Emission level (dB μ V/m) = 20 log Emission level (μ V/m)
9. Corrected Reading: Antenna Factor + Cable Loss + Read Level - Preamp Factor = Level

3.2.4. Test Setup of Radiated Emission

For radiated emissions from 30MHz to 1GHz

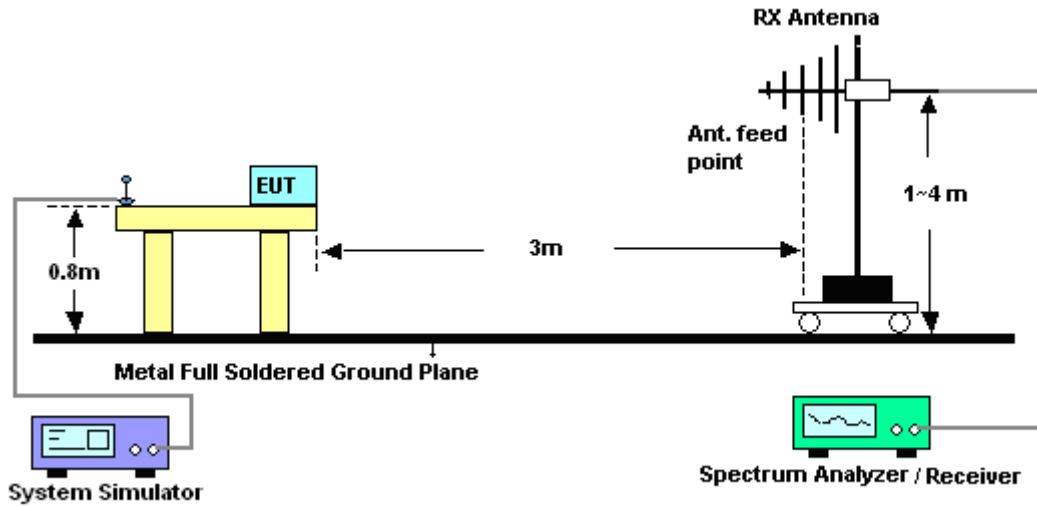

For radiated emissions above 1GHz

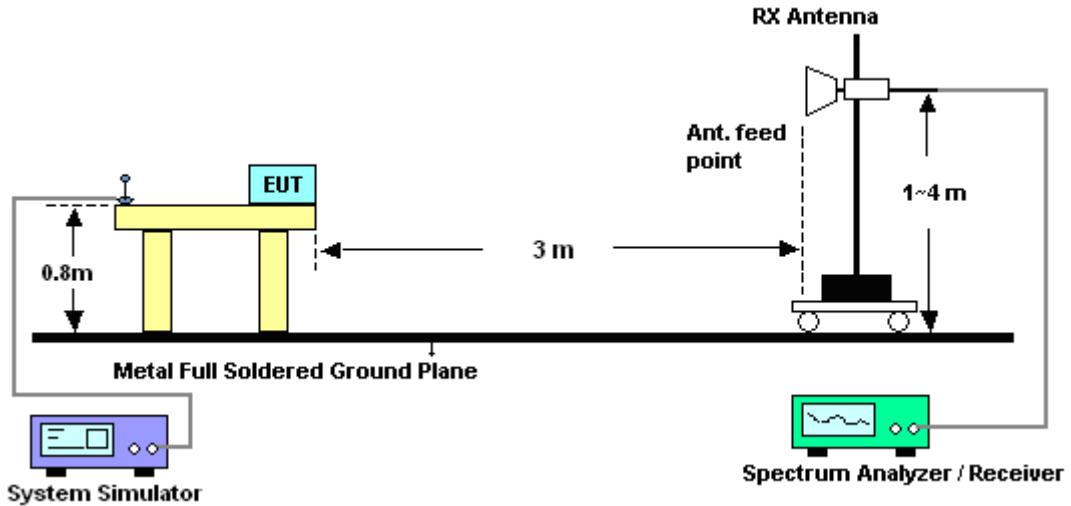



3.2.5. Test Result of Radiated Emission

Test Mode :	Mode 1	Temperature :	24~26°C
Test Engineer :	Robin Luo	Relative Humidity :	49~52%
Test Distance :	3m	Polarization :	Horizontal
Function Type :	GSM850 Idle + Bluetooth Idle + WLAN Idle + Adapter + Earphone + Camera		

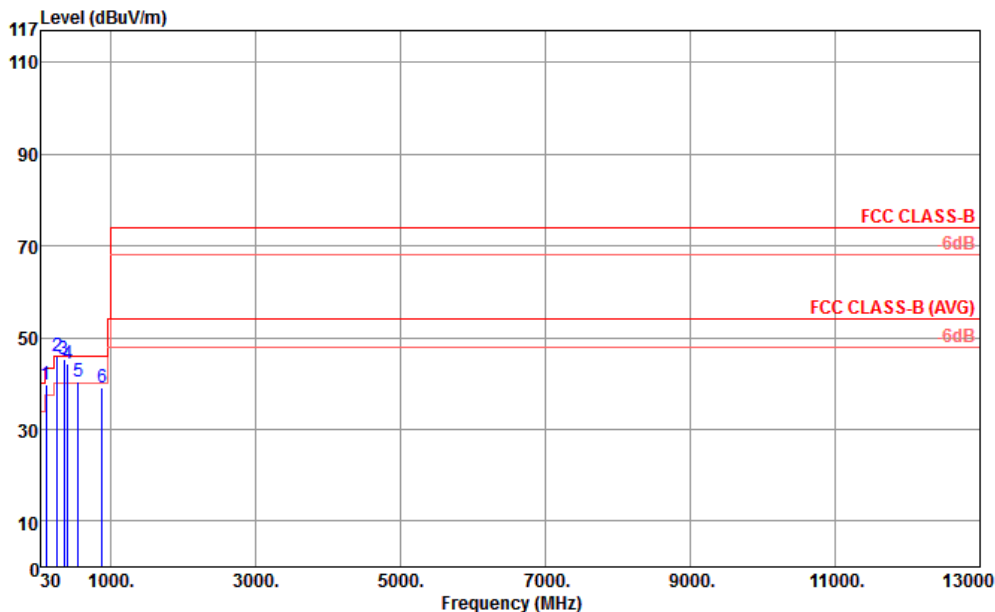

Site : 03CH01-SZ
 Condition : FCC CLASS-B 3m LF_ANT_121103 HORIZONTAL
 Project : (FC)393001
 Mode : Mode 1

	Freq	Level	Over	Limit	ReadAntenna	Cable	Preamp	A/Pos	T/Pos	Remark	
	MHz	dBuV/m	dB	dBuV/m	dBuV	dB/m	dB	dB	cm	deg	
1 P	107.60	39.83	-3.67	43.50	57.23	11.93	1.31	30.64	---	---	Peak
2 Q	263.77	45.93	-0.07	46.00	61.05	13.10	1.90	30.12	178	256	QP
3 !	359.80	45.46	-0.54	46.00	58.07	15.02	2.17	29.80	100	254	QP
4 !	408.30	44.22	-1.78	46.00	54.72	16.82	2.32	29.64	100	320	QP
5 !	551.86	40.37	-5.63	46.00	48.13	18.84	2.66	29.26	---	---	Peak
6	881.66	39.23	-6.77	46.00	43.87	20.90	3.29	28.83	---	---	Peak



Test Mode :	Mode 1	Temperature :	24~26°C
Test Engineer :	Robin Luo	Relative Humidity :	49~52%
Test Distance :	3m	Polarization :	Vertical
Function Type :	GSM850 Idle + Bluetooth Idle + WLAN Idle + Adapter + Earphone + Camera		

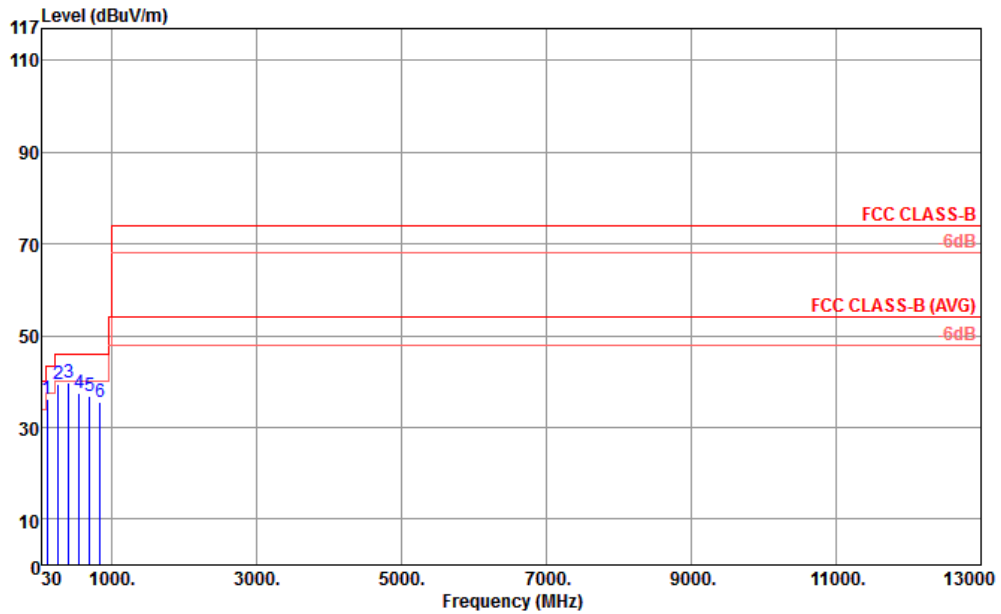

Site : 03CH01-SZ
 Condition : FCC CLASS-B 3m LF_ANT_121103 VERTICAL
 Project : (FC)393001
 Mode : Mode 1

	Freq	Level	Over	Limit	ReadAntenna	Cable	Preamp	A/Pos	T/Pos	Remark
	MHz	dBuV/m	Limit	Line	Level	Loss	Factor	cm	deg	
			dB	dBuV/m	dBuV	dB/m	dB	dB		
1	107.60	36.22	-7.28	43.50	53.62	11.93	1.31	30.64	---	Peak
2	263.77	39.55	-6.45	46.00	54.67	13.10	1.90	30.12	---	Peak
3 P	408.30	39.77	-6.23	46.00	50.27	16.82	2.32	29.64	112	205 Peak
4	551.86	37.57	-8.43	46.00	45.33	18.84	2.66	29.26	---	Peak
5	696.39	36.89	-9.11	46.00	43.64	19.36	2.96	29.07	---	Peak
6	839.95	35.66	-10.34	46.00	40.42	20.90	3.22	28.88	---	Peak



Test Mode :	Mode 3	Temperature :	24~26°C
Test Engineer :	Robin Luo	Relative Humidity :	49~52%
Test Distance :	3m	Polarization :	Horizontal
Function Type :	GSM1900 Idle + Bluetooth Idle + WLAN Idle + USB Cable (Data Link with Notebook) + Earphone		

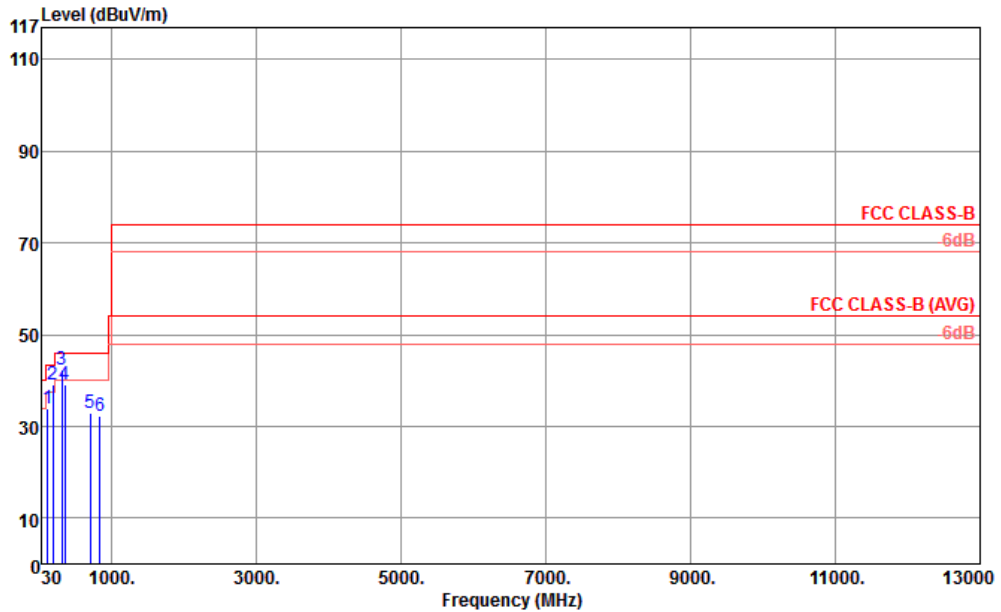

Site : 03CH01-SZ
 Condition : FCC CLASS-B 3m LF_ANT_121103 HORIZONTAL
 Project : (FC)393001
 Mode : Mode 3

	Freq	Level	Over Limit	Limit Line	ReadAntenna Level	Antenna Factor	Cable Loss	Preamp Factor	A/Pos	T/Pos	Remark
	MHz	dBuV/m	dB	dBuV/m	dBuV	dB/m	dB	dB	cm	deg	
1	120.21	33.86	-9.64	43.50	50.91	12.20	1.35	30.60	---	---	Peak
2	191.99	39.22	-4.28	43.50	58.25	9.67	1.66	30.36	---	---	QP
3	316.15	42.28	-3.72	46.00	56.41	13.76	2.06	29.95	132	248	QP
4	358.83	39.01	-6.99	46.00	51.62	15.02	2.17	29.80	---	---	Peak
5	707.06	32.95	-13.05	46.00	39.40	19.64	2.97	29.06	---	---	Peak
6	839.95	32.33	-13.67	46.00	37.09	20.90	3.22	28.88	---	---	Peak



Test Mode :	Mode 3	Temperature :	24~26°C
Test Engineer :	Robin Luo	Relative Humidity :	49~52%
Test Distance :	3m	Polarization :	Vertical
Function Type :	GSM1900 Idle + Bluetooth Idle + WLAN Idle + USB Cable (Data Link with Notebook) + Earphone		

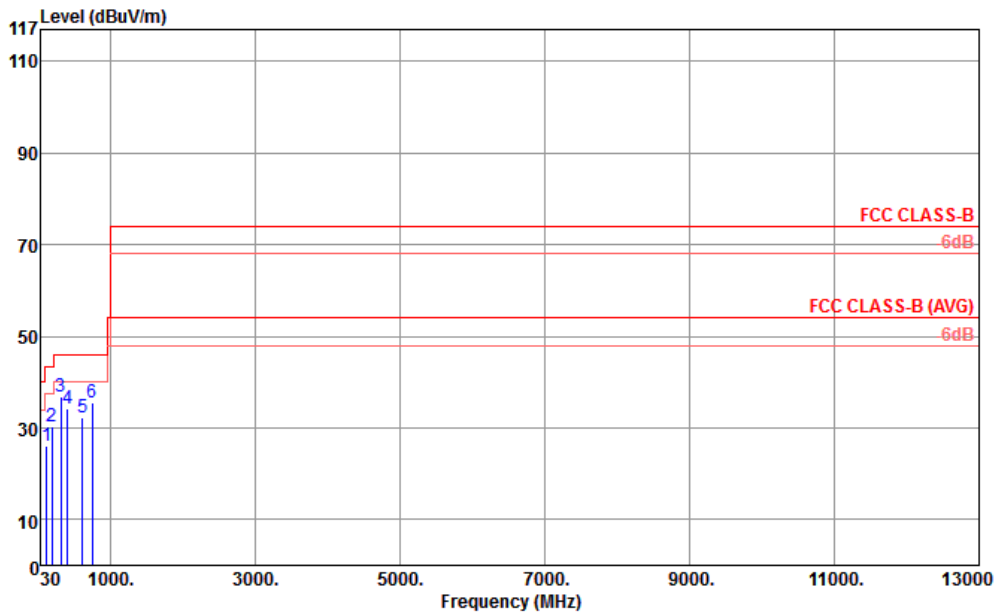

Site : 03CH01-SZ
 Condition : FCC CLASS-B 3m LF_ANT_121103 VERTICAL
 Project : (FC)393001
 Mode : Mode 3

	Freq	Level	Over Limit	Limit Line	ReadAntenna Level	Cable Loss	Preamp Loss	A/Pos	T/Pos	Remark	
	MHz	dBuV/m	dB	dBuV/m	dBuV	dB/m	dB	dB	cm	deg	
1	122.15	25.98	-17.52	43.50	42.96	12.25	1.36	30.59	---	---	Peak
2	191.99	30.38	-13.12	43.50	49.41	9.67	1.66	30.36	---	---	Peak
3 P	316.15	36.91	-9.09	46.00	51.04	13.76	2.06	29.95	200	360	Peak
4	408.30	34.22	-11.78	46.00	44.72	16.82	2.32	29.64	---	---	Peak
5	609.09	32.27	-13.73	46.00	39.48	19.20	2.78	29.19	---	---	Peak
6	741.98	35.43	-10.57	46.00	40.83	20.56	3.05	29.01	---	---	Peak

4. List of Measuring Equipment

Instrument	Manufacturer	Model No.	Serial No.	Characteristics	Calibration Date	Test Date	Due Date	Remark
ESCIO TEST Receiver	R&S	1142.8007.03	100724	9kHz~3GHz	Mar. 28, 2013	Oct. 08, 2013~ Oct. 16, 2013	Mar. 27, 2014	Conduction (CO01-SZ)
AC LISN	EMCO	3816/2SH	00103912	9kHz~30MHz	Mar. 28, 2013	Oct. 08, 2013~ Oct. 16, 2013	Mar. 27, 2014	Conduction (CO01-SZ)
AC LISN (for auxiliary equipment)	EMCO	3816/2SH	00103892	9kHz~30MHz	Mar. 28, 2013	Oct. 08, 2013~ Oct. 16, 2013	Mar. 27, 2014	Conduction (CO01-SZ)
AC Power Source	Chroma	61602	6160200008 91	N/A	Nov. 20, 2012	Oct. 08, 2013~ Oct. 16, 2013	Nov. 19, 2013	Conduction (CO01-SZ)
ESCI TEST Receiver	R&S	ESCI	100724	9K-3GHz	Mar. 28, 2013	Oct. 22, 2013	Mar. 27, 2014	Radiation (03CH01-SZ)
Spectrum Analyzer	R&S	FSP30	101362	9kHz~30GHz	Nov. 11, 2012	Oct. 22, 2013	Nov. 10, 2013	Radiation (03CH01-SZ)
Double Ridge Horn Antenna	ETS Lindgren	3117	00119436	1GHz~18GHz	Nov. 12, 2012	Oct. 22, 2013	Nov. 11, 2013	Radiation (03CH01-SZ)
Bilog Antenna	SCHAFFNER	CBL6112B	2614	30Mhz~2Ghz	Nov. 03, 2012	Oct. 22, 2013	Nov. 02, 2013	Radiation (03CH01-SZ)
Amplifier	ADVANTEST	BB525C	E9007003	9K-3000MHz GAIN 30db	Mar. 28, 2013	Oct. 22, 2013	Mar. 27, 2014	Radiation (03CH01-SZ)
Amplifier	Yiai	AV3860B	04030	2GHz~26.5GHz	Mar. 28, 2013	Oct. 22, 2013	Mar. 27, 2014	Radiation (03CH01-SZ)
Turn Table	EM Electronics	EM 1000	N/A	0 ~ 360 degree	N/A	Oct. 22, 2013	N/A	Radiation (03CH01-SZ)
Antenna Mast	EM Electronics	EM 1000	N/A	1 m - 4 m	N/A	Oct. 22, 2013	N/A	Radiation (03CH01-SZ)

5. Uncertainty of Evaluation

Uncertainty of Conducted Emission Measurement (150 kHz ~ 30 MHz)

Measuring Uncertainty for a Level of Confidence of 95% ($U = 2Uc(y)$)	2.26
---	------

Uncertainty of Radiated Emission Measurement (30 MHz ~ 1000 MHz)

Measuring Uncertainty for a Level of Confidence of 95% ($U = 2Uc(y)$)	2.54
---	------

Uncertainty of Radiated Emission Measurement (1 GHz ~ 40 GHz)

Measuring Uncertainty for a Level of Confidence of 95% ($U = 2Uc(y)$)	4.72
---	------