

FCC Test Report

APPLICANT : Brightstar Coporation
EQUIPMENT : GSM mobile phone
BRAND NAME : Avvio
MODEL NAME : Avvio SN52S/SN52
MARKETING NAME : Avvio SN52S/SN52
FCC ID : WVBASN52
STANDARD : FCC 47 CFR FCC Part 15 Subpart B
CLASSIFICATION : Certification

The product was received on Sep. 12, 2012 and completely tested on Oct. 08, 2012. We, SPORTON INTERNATIONAL (KUNSHAN) INC., would like to declare that the tested sample has been evaluated in accordance with the procedures given in ANSI C63.4-2003 and shown the compliance with the applicable technical standards.

The test results in this report apply exclusively to the tested model / sample. Without written approval of SPORTON INTERNATIONAL (KUNSHAN) INC., the test report shall not be reproduced except in full.

Reviewed by:



Jones Tsai / Manager



SPORTON INTERNATIONAL (KUNSHAN) INC.
No. 3-2, PingXiang Road, Kunshan, Jiangsu Province, P.R.C.



TABLE OF CONTENTS

REVISION HISTORY..... 3

SUMMARY OF TEST RESULT 4

1. GENERAL DESCRIPTION 5

 1.1. Applicant..... 5

 1.2. Manufacturer 5

 1.3. Feature of Equipment Under Test..... 6

 1.4. Test Site 7

 1.5. Applied Standards 7

 1.6. Ancillary Equipment List..... 7

2. TEST CONFIGURATION OF EQUIPMENT UNDER TEST 8

 2.1. Test Mode 8

 2.2. Connection Diagram of Test System 10

 2.3. Test Software 12

3. TEST RESULT 13

 3.1. Test of AC Conducted Emission Measurement 13

 3.2. Test of Radiated Emission Measurement 19

4. LIST OF MEASURING EQUIPMENT 23

5. UNCERTAINTY OF EVALUATION 24

APPENDIX A. PHOTOGRAPHS OF EUT

APPENDIX B. SETUP PHOTOGRAPHS



SUMMARY OF TEST RESULT

Report Section	FCC Rule	IC Rule	Description	Limit	Result	Remark
3.1	15.107	7.2.4	AC Conducted Emission	< 15.107 limits < RSS-Gen table 2 limits	PASS	Under limit 7.69 dB at 0.370 MHz
3.2	15.109	7.2.3.2	Radiated Emission	< 15.109 limits or < RSS-Gen table 1 limits (Section 6)	PASS	Under limit 3.33 dB at 485.900 MHz for Quasi-Peak



1. General Description

1.1. Applicant

Brightstar Coporation

9725 NW 117th Ave., Miami, Florida, United States

1.2. Manufacturer

Shanghai Huaqin Telecom Technology Co., Ltd.

Building 12, 399 Keyuan Road, Pudong district, Shanghai, China

1.3. Feature of Equipment Under Test

Product Feature	
Equipment	GSM mobile phone
Brand Name	Avvio
Model Name	Avvio SN52S/SN52
Marketing Name	Avvio SN52S/SN52
FCC ID	WVBASN52
EUT supports Radios application	GSM/GPRS/WLAN 11bgn/Bluetooth 3.0 EDR
HW Version	V298_MB_V1.0
SW Version	ZV298PAC_057A_V0_0_1
EUT Stage	Identical Prototype

Remark:

1. The above EUT's information was declared by manufacturer. Please refer to the specifications or user's manual for more detailed description.
2. There are two different types of EUT. They are single SIM card mobile (Model Name: Avvio SN52) and dual SIM card mobile (Model Name: Avvio SN52S). The others are the same including circuit design, PCB board, structure and all components. It is special to declare. After pre-scan two types of EUT, we found test result of the sample that dual SIM was the worst, so we choose dual SIM card mobile to perform all tests.

Product Specification subjective to this standard	
Tx Frequency	GSM850: 824.2 MHz ~ 848.8 MHz GSM1900: 1850.2 MHz ~ 1909.8MHz 802.11b/g/n: 2412 MHz ~ 2462 MHz Bluetooth: 2402 MHz ~ 2480 MHz
Rx Frequency Range	GSM850: 869.2 MHz ~ 893.8 MHz GSM1900: 1930.2 MHz ~ 1989.8 MHz 802.11b/g/n: 2412 MHz ~ 2462 MHz Bluetooth: 2402 MHz ~ 2480 MHz FM: 88 MHz ~ 108 MHz
Antenna Type	WWAN : PIFA Antenna WLAN : PIFA Antenna Bluetooth : PIFA Antenna
Type of Modulation	GSM: GMSK GPRS: GMSK EDGE: GMSK / 8PSK (Downlink only) 802.11b : DSSS (BPSK / QPSK / CCK) 802.11g/n : OFDM (BPSK / QPSK / 16QAM / 64QAM) Bluetooth 3.0 EDR : GFSK, $\pi/4$ -DQPSK, 8-DPSK FM

1.4. Test Site

Test Site	SPORTON INTERNATIONAL (KUNSHAN) INC.		
Test Site Location	No. 3-2, PingXiang Road, Kunshan, Jiangsu Province, P.R.C. TEL: +86-0512-5790-0158 FAX: +86-0512-5790-0958		
Test Site No.	Sporton Site No.		FCC/IC Registration No.
	CO01-KS	03CH01-KS	149928/4086E-1

1.5. Applied Standards

According to the specifications of the manufacturer, the EUT must comply with the requirements of the following standards:

- FCC 47 CFR FCC Part 15 Subpart B
- ANSI C63.4-2003
- IC RSS-Gen Issue 3

Remark: All test items were verified and recorded according to the standards and without any deviation during the test.

1.6. Ancillary Equipment List

Item	Equipment	Trade Name	Model Name	FCC ID	Data Cable	Power Cord
1.	System Simulator	R&S	CMU 200	N/A	N/A	Unshielded, 1.8 m
2.	Signal Generator	R&S	SMR40	FCC DoC	Shielded, 1.6 m	Unshielded, 1.8 m
3.	PC	Dell	MT380	FCC DoC	N/A	Unshielded, 1.8 m
4.	WLAN AP	D-link	DIR-855	KA2DIR855A2	N/A	Unshielded, 1.8 m
5.	Bluetooth Earphone	Nokia	BH-102	PYAHS-107W	N/A	N/A
6.	Bluetooth Earphone	Nokia	BH-106	QTLBH-106	N/A	N/A
7.	Monitor	Dell	E1910Hc	FCC DoC	Shielded, 1.2 m	Unshielded, 1.8 m
8.	(USB) Keyboard	Dell	SK-8115	FCC DoC	Shielded, 1.5 m	N/A
9.	(USB) Keyboard	Dell	L100	FCC DoC	Shielded, 1.8 m with Core	N/A
10.	(USB) Mouse	Dell	N231	FCC DoC	Shielded, 1.8 m	N/A
11.	(USB) Mouse	Dell	MO56UC	FCC DoC	Shielded, 1.8 m	N/A
12.	Printer	HP	Laser Jet 1018	FCC DoC	Shielded, 1.8 m	Unshielded, 1.8 m
13.	iPod	Apple	A1199	FCC DoC	Shielded, 1.2 m	N/A

2. Test Configuration of Equipment Under Test

2.1. Test Mode

The EUT has been associated with peripherals pursuant to ANSI C63.4-2003 and configuration operated in a manner tended to maximize its emission characteristics in a typical application.

Frequency range investigated: conduction (150 KHz to 30 MHz), radiation (30MHz to the 5th harmonic of the highest fundamental frequency or to 40 GHz, whichever is lower).

The following tables are showing the test modes as the worst cases and recorded in this report.

Item	EUT Configuration	Test Condition		
		EMI AC	EMI RE<1G	EMI RE≥1G
1.	Charging Mode (EUT with adapter)	☒	☒	Note 1
2.	Data application transferred mode (EUT with PC)	☒	☒	☒

Abbreviations:

- EMI AC: AC conducted emissions
- EMI RE ≥ 1G: EUT radiated emissions ≥ 1GHz
- EMI RE < 1G: EUT radiated emissions < 1GHz

Note 1: Testing for this mode is not required or not the worst case.

Remark: For signal above 1GHz, the worst case was test item 2.

Test Items	EUT Configure Mode	Function Type
AC Conducted Emission	1/2	Mode 1: GSM850 Idle + USB Cable (Charging from Adapter) + WLAN Idle + Bluetooth Idle + Earphone + Camera + SIM 1 <Fig. 1> Mode 2: GSM1900 Idle + USB Cable (Charging from Adapter) + WLAN Idle + Bluetooth Idle + Earphone + MPEG4 + SIM 1 <Fig. 1> Mode 3: GSM850 Idle + USB Cable (Charging from Adapter) + WLAN Idle + Bluetooth Idle + Earphone + FM Rx + SIM 1 <Fig. 2> Mode 4: GSM1900 Idle + USB Cable (Data Link with PC) + WLAN Idle + Bluetooth Idle + Earphone + SIM 1 <Fig. 3>
Radiated Emissions < 1GHz	1/2	Mode 1: GSM850 Idle + USB Cable (Charging from Adapter) + WLAN Idle + Bluetooth Idle + Earphone + Camera + SIM 1 <Fig. 1> Mode 2: GSM1900 Idle + USB Cable (Charging from Adapter) + WLAN Idle + Bluetooth Idle + Earphone + MPEG4 + SIM 1 <Fig. 1> Mode 3: GSM850 Idle + USB Cable (Charging from Adapter) + WLAN Idle + Bluetooth Idle + Earphone + FM Rx + SIM 1 <Fig. 2> Mode 4: GSM1900 Idle + USB Cable (Data Link with PC) + WLAN Idle + Bluetooth Idle + Earphone + SIM 1 <Fig. 3>
Radiated Emissions ≥ 1GHz	2	Mode 1: GSM1900 Idle + USB Cable (Data Link with PC) + WLAN Idle + Bluetooth Idle + Earphone + SIM 1 <Fig. 3>
Remark: <ol style="list-style-type: none"> The worst case of AC Conducted Emission is mode 2; the test data of this mode was reported. The USB Link mode of AC Conducted Emission is mode 4; the test data of this mode was also reported. The worst case of Radiated Emissions is mode 4; only the test data of this mode was reported. Link with PC means data application transferred mode between EUT and PC. 		

2.2. Connection Diagram of Test System

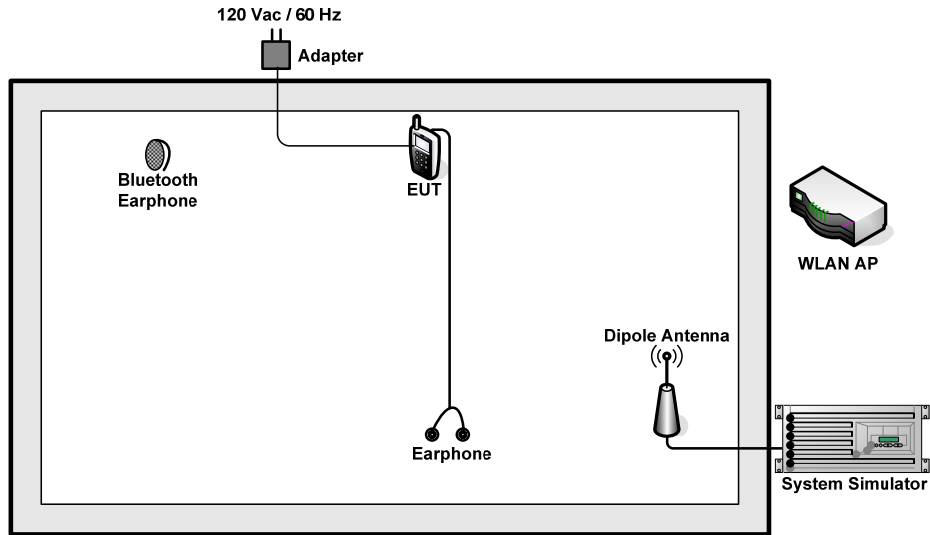

<Fig. 1>

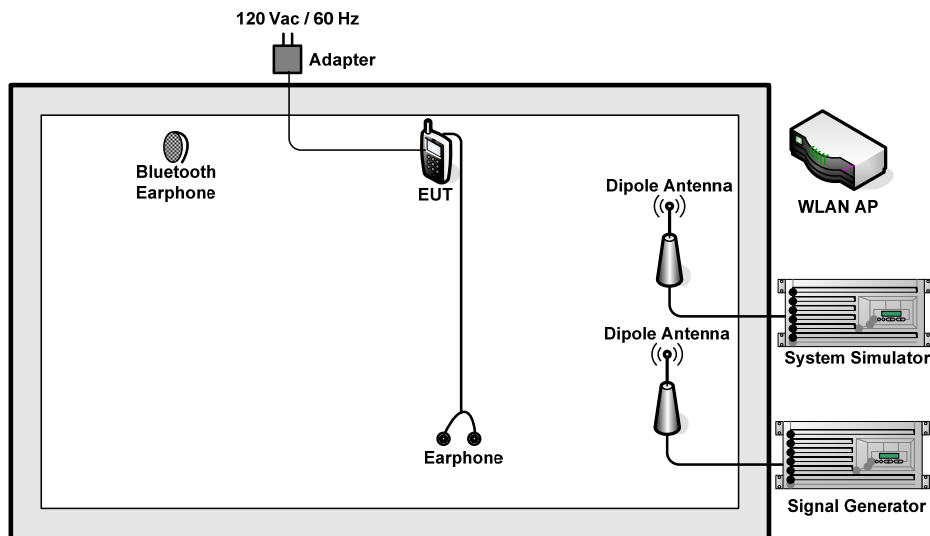

<Fig. 2>

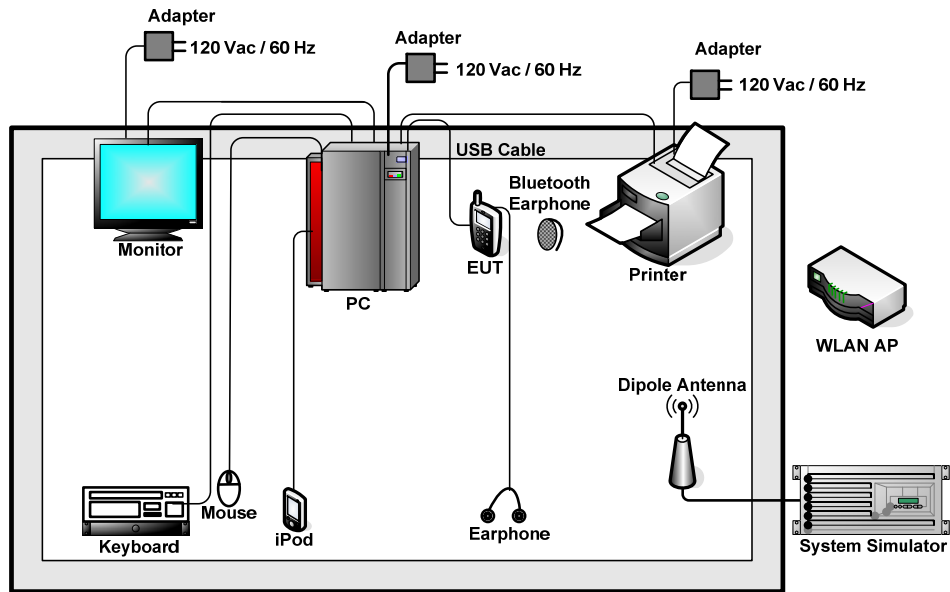

<Fig. 3>

2.3. Test Software

The EUT was in GSM idle mode during the testing. The EUT was synchronized to the BCCH, and is in continuous receiving mode by setting system simulator's paging reorganization.

At the same time, the EUT was attached to the Bluetooth earphone or WLAN AP, and the following programs installed in the EUT were programmed during the test.

1. Execute the program, "Winthrax" under WIN7 installed in PC for files transfer with EUT via USB cable.
2. Turn on FM function to keep EUT receiving continuous signals from Signal Generator.
3. Execute "Windows Media Player" to play MPEG4 files.
4. Turn on camera to capture images.

3. Test Result

3.1. Test of AC Conducted Emission Measurement

3.1.1 Limits of AC Conducted Emission

For equipment that is designed to be connected to the public utility (AC) power line, the radio frequency voltage that is conducted back onto the AC power line on any frequency or frequencies within the band 150 KHz to 30 MHz shall not exceed the limits in the following table.

Frequency of emission (MHz)	Conducted limit (dBuV)	
	Quasi-peak	Average
0.15-0.5	66 to 56*	56 to 46*
0.5-5	56	46
5-30	60	50

*Decreases with the logarithm of the frequency.

3.1.2 Measuring Instruments

See list of measuring instruments of this test report.

3.1.3 Test Procedure

1. The EUT was placed 0.4 meter from the conducting wall of the shielding room was kept at least 80 centimeters from any other grounded conducting surface.
2. Connect EUT to the power mains through a line impedance stabilization network (LISN).
3. All the support units are connecting to the other LISN.
4. The LISN provides 50 ohm coupling impedance for the measuring instrument.
5. The FCC states that a 50 ohm, 50 microhenry LISN should be used.
6. Both sides of AC line were checked for maximum conducted interference.
7. The frequency range from 150 KHz to 30 MHz was searched.
8. Set the test-receiver system to Peak Detect Function and specified bandwidth with Maximum Hold Mode.

3.1.4 Test Setup

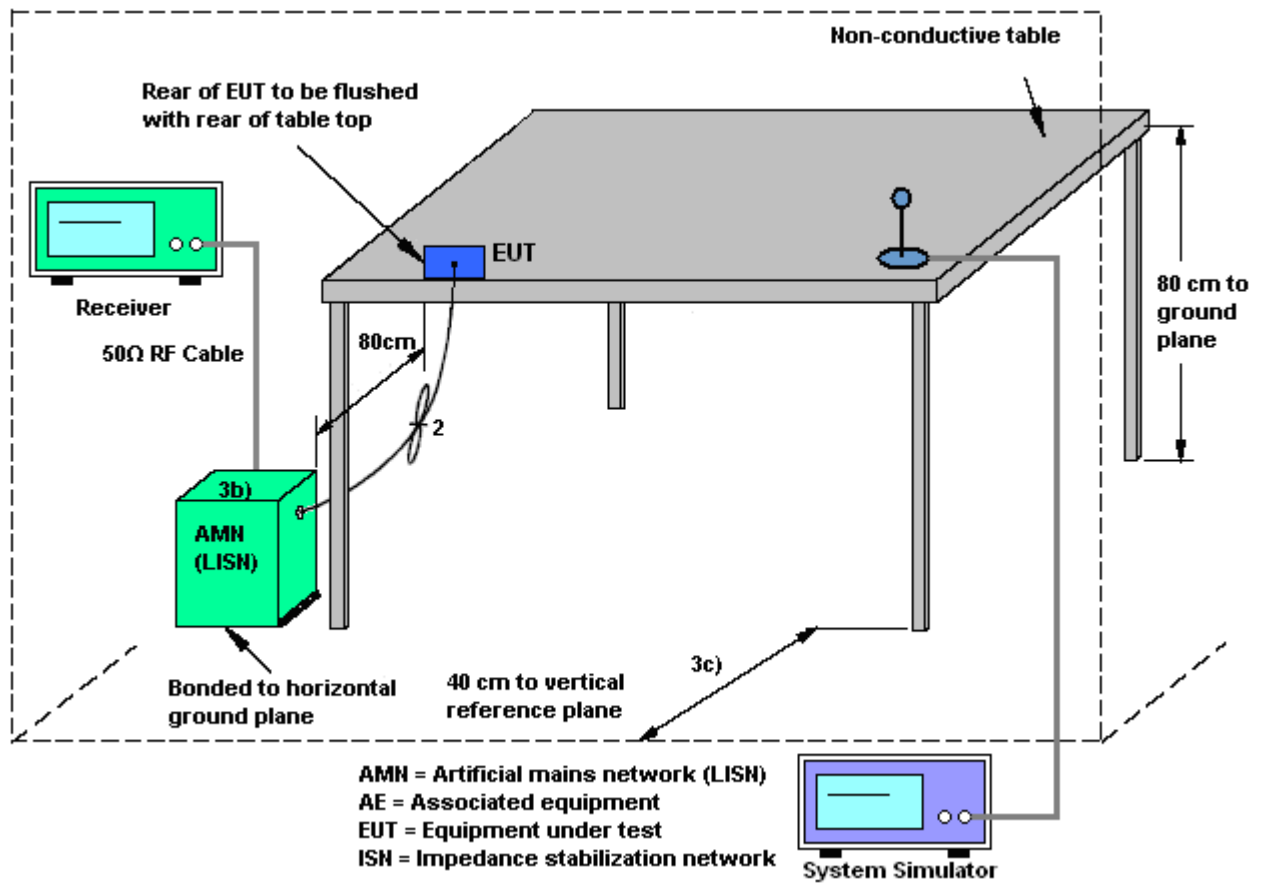

3.1.5 Test Result of AC Conducted Emission

Test Mode :	Mode 2	Temperature :	19~20°C
Test Engineer :	Tom Wang	Relative Humidity :	39~40%
Test Voltage :	120Vac / 60Hz	Phase :	Line
Function Type :	GSM1900 Idle + USB Cable (Charging from Adapter) + WLAN Idle + Bluetooth Idle + Earphone + MPEG4 + SIM 1		
Remark :	All emissions not reported here are more than 10 dB below the prescribed limit.		

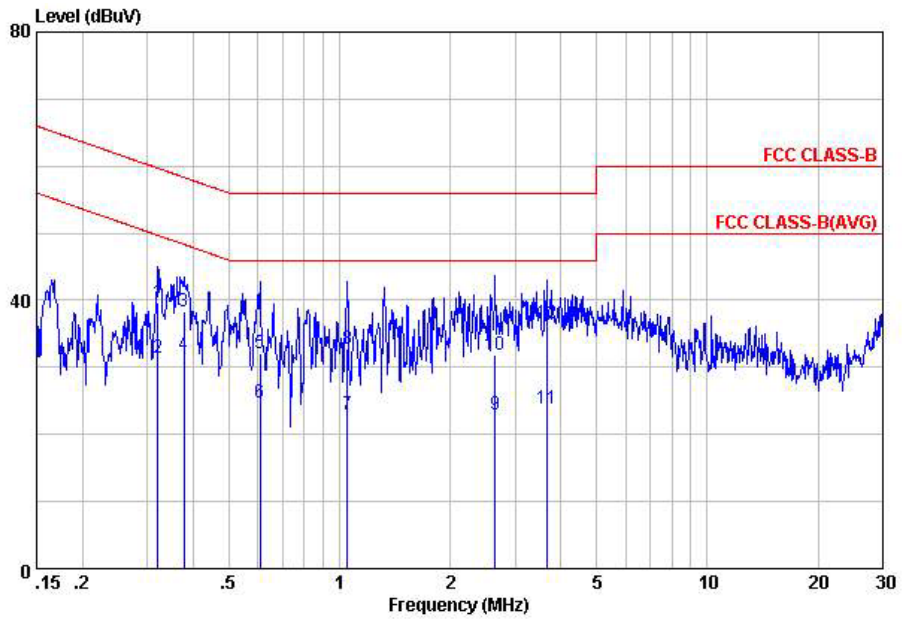

Site : C001-KS
 Condition: FCC CLASS-B LISN-111230 LINE
 mode : Mode 2

	Freq	Level	Over	Limit	Read	LISN	Cable	Remark
	MHz	dBuV	Limit	Line	Level	Factor	Loss	
			dB	dBuV	dBuV	dB	dB	
1	0.32	39.72	-19.99	59.71	29.21	-0.08	10.59	QP
2	0.32	31.42	-18.29	49.71	20.91	-0.08	10.59	Average
3	0.38	38.44	-19.90	58.34	27.91	-0.08	10.61	QP
4	0.38	31.94	-16.40	48.34	21.41	-0.08	10.61	Average
5	0.61	32.05	-23.95	56.00	21.51	-0.09	10.63	QP
6	0.61	24.85	-21.15	46.00	14.31	-0.09	10.63	Average
7	1.05	22.85	-23.15	46.00	12.30	-0.10	10.65	Average
8	1.05	32.75	-23.25	56.00	22.20	-0.10	10.65	QP
9	2.65	22.93	-23.07	46.00	12.30	-0.11	10.74	Average
10	2.65	31.83	-24.17	56.00	21.20	-0.11	10.74	QP
11	3.66	23.80	-22.20	46.00	13.10	-0.12	10.82	Average
12	3.66	36.60	-19.40	56.00	25.90	-0.12	10.82	QP



Test Mode :	Mode 2	Temperature :	19~20°C
Test Engineer :	Tom Wang	Relative Humidity :	39~40%
Test Voltage :	120Vac / 60Hz	Phase :	Neutral
Function Type :	GSM1900 Idle + USB Cable (Charging from Adapter) + WLAN Idle + Bluetooth Idle + Earphone + MPEG4 + SIM 1		
Remark :	All emissions not reported here are more than 10 dB below the prescribed limit.		

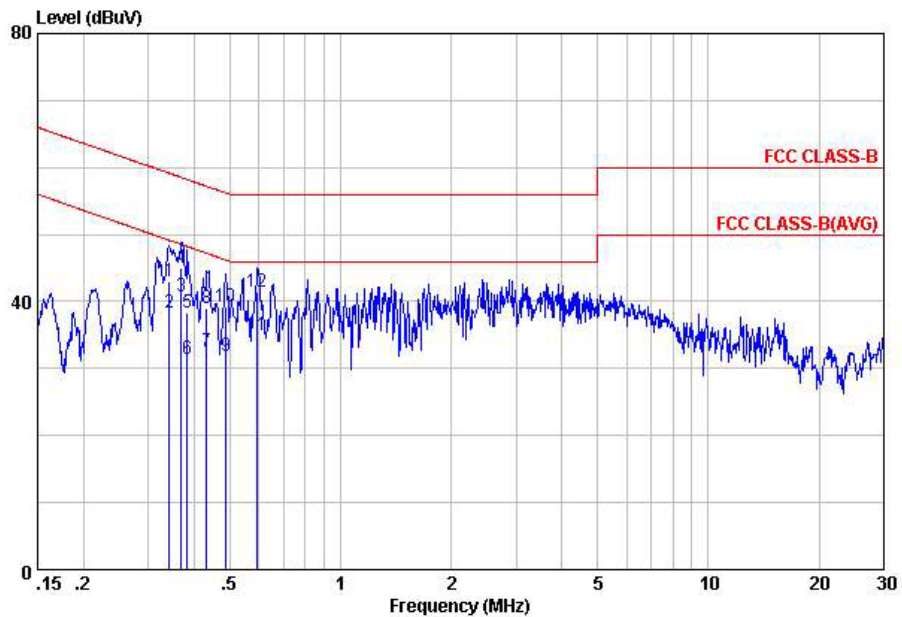

Site : C001-KS
 Condition: FCC CLASS-B LISN-111230 NEUTRAL

mode : Mode 2

	Freq	Level	Over	Limit	Read	LISN	Cable	Remark
	MHz	dBuV	Limit	Line	Level	Factor	Loss	
			dB	dBuV	dBuV	dB	dB	
1	0.34	42.93	-16.20	59.13	32.41	-0.08	10.60	QP
2	0.34	38.33	-10.80	49.13	27.81	-0.08	10.60	Average
3	0.37	40.83	-7.69	48.52	30.30	-0.08	10.61	Average
4	0.37	44.93	-13.59	58.52	34.40	-0.08	10.61	QP
5	0.38	38.44	-19.77	58.21	27.90	-0.08	10.62	QP
6	0.38	31.44	-16.77	48.21	20.90	-0.08	10.62	Average
7	0.43	32.54	-14.66	47.20	22.00	-0.08	10.62	Average
8	0.43	38.94	-18.26	57.20	28.40	-0.08	10.62	QP
9	0.49	31.84	-14.35	46.19	21.30	-0.08	10.62	Average
10	0.49	39.14	-17.05	56.19	28.60	-0.08	10.62	QP
11	0.59	34.95	-11.05	46.00	24.40	-0.08	10.63	Average
12	0.59	41.35	-14.65	56.00	30.80	-0.08	10.63	QP



Test Mode :	Mode 4	Temperature :	19~20°C
Test Engineer :	Tom Wang	Relative Humidity :	39~40%
Test Voltage :	120Vac / 60Hz	Phase :	Line
Function Type :	GSM1900 Idle + USB Cable (Data Link with PC) + WLAN Idle + Bluetooth Idle + Earphone + SIM 1		
Remark :	All emissions not reported here are more than 10 dB below the prescribed limit.		

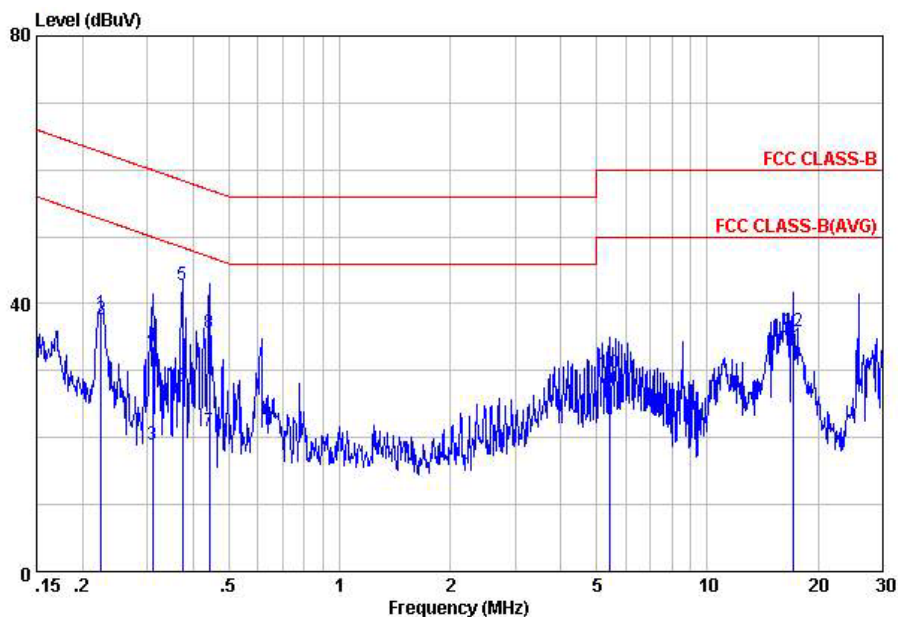

Site : C001-KS
 Condition: FCC CLASS-B LISN-111230 LINE

mode : Mode 4

	Freq	Level	Over	Limit	Read	LISN	Cable	Remark
	MHz	dBuV	Limit	Line	Level	Factor	Loss	
			dB	dBuV	dBuV	dB	dB	
1	0.22	38.64	-24.02	62.66	28.20	-0.07	10.51	QP
2	0.22	37.74	-14.92	52.66	27.30	-0.07	10.51	Average
3	0.31	19.01	-30.96	49.97	8.49	-0.07	10.59	Average
4	0.31	33.61	-26.36	59.97	23.09	-0.07	10.59	QP
5	0.37	42.74	-15.69	58.43	32.21	-0.08	10.61	QP
6	0.37	27.64	-20.79	48.43	17.11	-0.08	10.61	Average
7	0.44	21.04	-25.98	47.02	10.50	-0.08	10.62	Average
8	0.44	35.64	-21.38	57.02	25.10	-0.08	10.62	QP
9	5.42	27.23	-22.77	50.00	16.50	-0.13	10.86	Average
10	5.42	29.63	-30.37	60.00	18.90	-0.13	10.86	QP
11	17.11	33.66	-16.34	50.00	22.61	0.02	11.03	Average
12	17.11	35.96	-24.04	60.00	24.91	0.02	11.03	QP



Test Mode :	Mode 4	Temperature :	19~20°C
Test Engineer :	Tom Wang	Relative Humidity :	39~40%
Test Voltage :	120Vac / 60Hz	Phase :	Neutral
Function Type :	GSM1900 Idle + USB Cable (Charging from Adapter) + WLAN Idle + Bluetooth Idle + Earphone + MPEG4 + SIM 1		
Remark :	All emissions not reported here are more than 10 dB below the prescribed limit.		

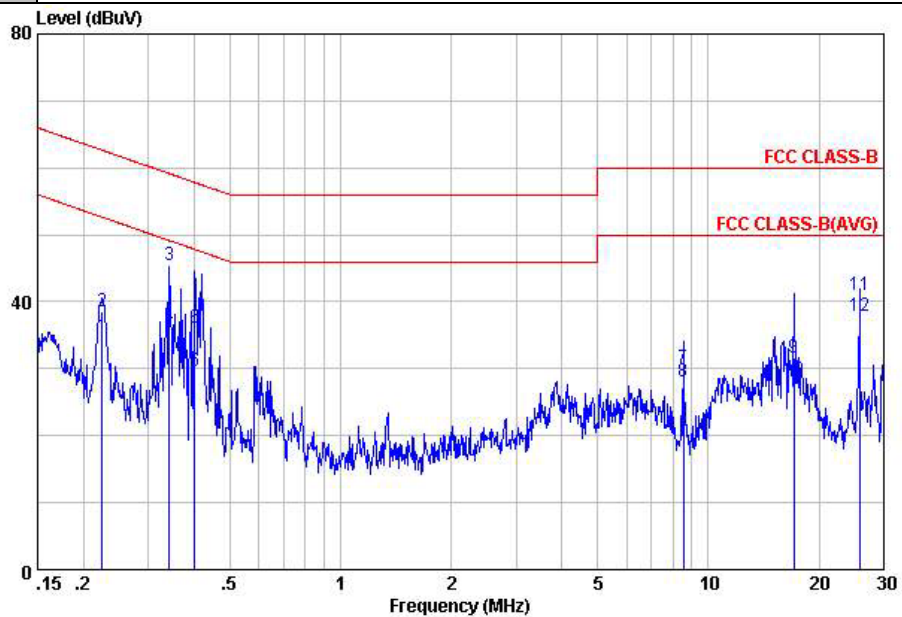

Site : C001-KS
 Condition: FCC CLASS-B LISN-111230 NEUTRAL

mode : Mode 4

	Freq	Level	Over	Limit	Read	LISN	Cable	Remark
	MHz	dBuV	Limit	Line	Level	Factor	Loss	
			dB	dBuV	dBuV	dB	dB	
1	0.22	34.74	-17.92	52.66	24.30	-0.07	10.51	Average
2	0.22	38.64	-24.02	62.66	28.20	-0.07	10.51	QP
3	0.34	45.53	-13.60	59.13	35.01	-0.08	10.60	QP
4	0.34	36.23	-12.90	49.13	25.71	-0.08	10.60	Average
5	0.40	29.74	-18.07	47.81	19.20	-0.08	10.62	Average
6	0.40	36.04	-21.77	57.81	25.50	-0.08	10.62	QP
7	8.55	30.02	-29.98	60.00	19.20	-0.13	10.95	QP
8	8.55	28.02	-21.98	50.00	17.20	-0.13	10.95	Average
9	17.11	31.54	-28.46	60.00	20.50	0.01	11.03	QP
10	17.11	28.24	-21.76	50.00	17.20	0.01	11.03	Average
11	25.73	41.09	-18.91	60.00	29.81	0.15	11.13	QP
12	25.73	37.79	-12.21	50.00	26.51	0.15	11.13	Average

3.2. Test of Radiated Emission Measurement

3.2.1. Limit of Radiated Emission

The emissions from an unintentional radiator shall not exceed the field strength levels specified in the following table:

Frequency (MHz)	Field Strength (microvolts/meter)	Measurement Distance (meters)
30 – 88	100	3
88 – 216	150	3
216 - 960	200	3
Above 960	500	3

3.2.2. Measuring Instruments

See list of measuring instruments of this test report.

3.2.3. Test Procedures

1. The EUT was placed on a turntable with 0.8 meter above ground.
2. The EUT was set 3 meters from the interference receiving antenna, which was mounted on the top of a variable height antenna tower.
3. The table was rotated 360 degrees to determine the position of the highest radiation.
4. The antenna height is adjusted between one to four meters above ground to find the maximum value of the field strength for both horizontal polarization and vertical polarization of the antenna.
5. For each suspected emission, the EUT was arranged to its worst case and then tune the antenna tower (from 1 m to 4 m) and turntable (from 0 degree to 360 degrees) to find the maximum reading.
6. Set the test-receiver system to Peak Detect Function and specified bandwidth with Maximum Hold Mode.
7. If the emission level of the EUT in peak mode was 3 dB lower than the limit specified, peak values of EUT will be reported. Otherwise, the emission will be repeated by using the quasi-peak method and reported.
8. Emission level (dBuV/m) = 20 log Emission level (uV/m)
9. Corrected Reading: Antenna Factor + Cable Loss + Read Level - Preamp Factor= Level

3.2.4. Test Setup of Radiated Emission

For radiated emissions from 30MHz to 1GHz

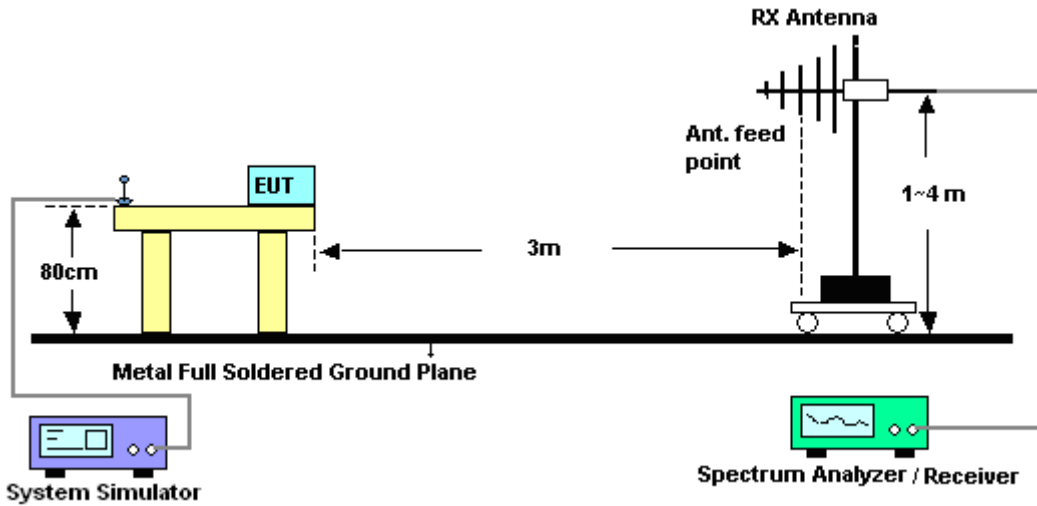

For radiated emissions above 1GHz

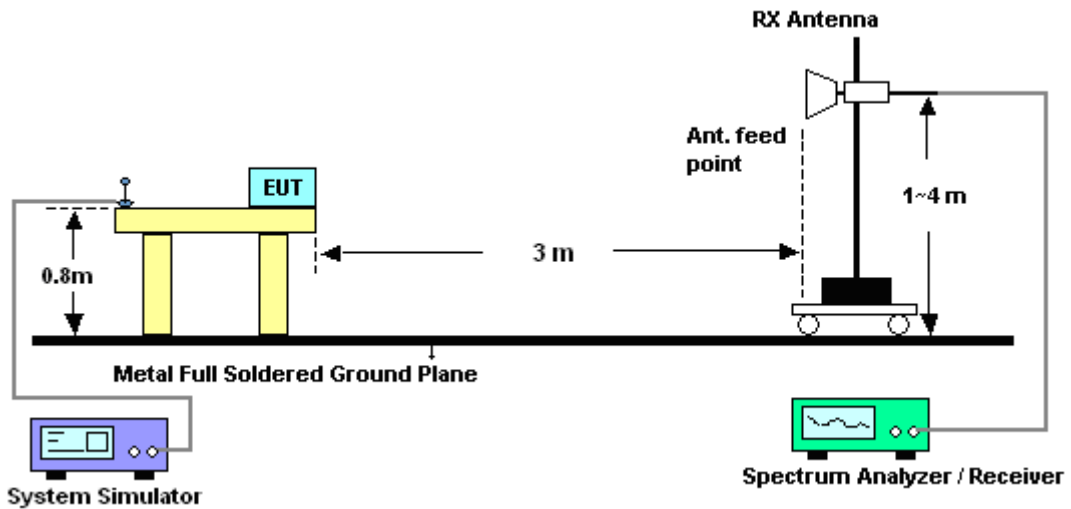

3.2.5. Test Result of Radiated Emission

Test Mode :	Mode 4	Temperature :	22~23°C
Test Engineer :	Jack Li	Relative Humidity :	42~44%
Test Distance :	3m	Polarization :	Horizontal
Function Type :	GSM1900 Idle + USB Cable (Data Link with PC) + WLAN Idle + Bluetooth Idle + Earphone + SIM 1		

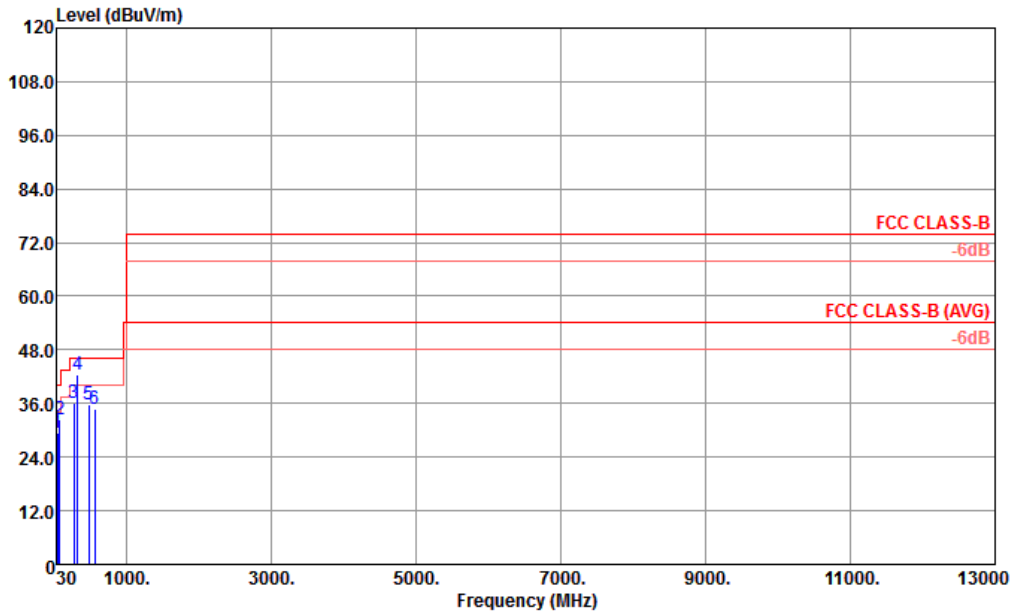

Site : 03CH01-KS
 Condition : FCC CLASS-B 3m LF_ANT_100803 HORIZONTAL

Mode : mode 4

	Freq	Level	Over Limit	Limit Line	ReadAntenna Level	Factor	Cable Loss	Preamp Factor	A/Pos	T/Pos	Remark
	MHz	dBuV/m	dB	dBuV/m	dBuV	dB/m	dB	dB	cm	deg	
1	44.55	29.54	-10.46	40.00	49.80	9.60	0.27	30.13	---	---	Peak
2	79.47	32.45	-7.55	40.00	55.67	6.47	0.35	30.04	---	---	Peak
3	275.41	35.96	-10.04	46.00	52.66	12.53	0.70	29.93	---	---	Peak
4	323.91	42.59	-3.41	46.00	58.06	13.71	0.77	29.95	188	317	Peak
5	480.08	35.76	-10.24	46.00	47.70	16.87	0.94	29.75	---	---	Peak
6	564.47	34.89	-11.11	46.00	45.02	18.52	1.02	29.67	---	---	Peak



Test Mode :	Mode 4	Temperature :	22~23°C
Test Engineer :	Jack Li	Relative Humidity :	42~44%
Test Distance :	3m	Polarization :	Vertical
Function Type :	GSM1900 Idle + USB Cable (Data Link with PC) + WLAN Idle + Bluetooth Idle + Earphone + SIM 1		

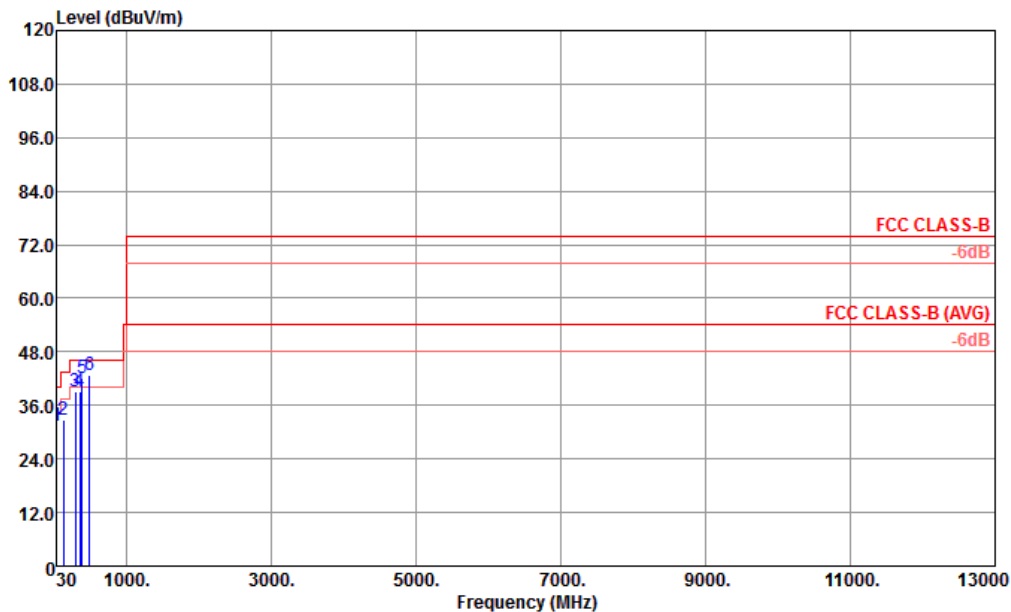

Site : 03CH01-KS
 Condition : FCC CLASS-B 3m LF_ANT_100803 VERTICAL

Mode : mode 4

	Freq	Level	Over	Limit	ReadAntenna	Cable	Preamp	A/Pos	T/Pos	Remark	
	MHz	dBuV/m	dB	dBuV/m	dBuV	dB/m	dB	dB	cm	deg	
1	32.91	31.36	-8.64	40.00	45.17	16.04	0.24	30.09	---	---	Peak
2	131.85	32.74	-10.76	43.50	50.71	11.55	0.47	29.99	---	---	Peak
3	288.02	38.99	-7.01	46.00	55.41	12.82	0.71	29.95	---	---	Peak
4	359.80	39.23	-6.77	46.00	53.61	14.72	0.82	29.92	---	---	Peak
5 !	384.05	42.13	-3.87	46.00	55.57	15.59	0.83	29.86	---	---	Peak
6 !	485.90	42.67	-3.33	46.00	54.47	16.99	0.95	29.74	100	0	QP



4. List of Measuring Equipment

Instrument	Manufacturer	Model No.	Serial No.	Characteristics	Calibration Date	Test Date	Due Date	Remark
EMI Receiver	R&S	ESCI7	100768	9kHz~7GHz	Jun. 01, 2012	Sep. 29, 2012	May 31, 2013	Conduction (CO01-KS)
LISN	MessTec	AN3016	60103	9kHz~30MHz	Dec. 30, 2011	Sep. 29, 2012	Dec. 29, 2012	Conduction (CO01-KS)
LISN	MessTec	AN3016	60105	9kHz~30MHz	Dec. 30, 2011	Sep. 29, 2012	Dec. 29, 2012	Conduction (CO01-KS)
AC Power Source	Chroma	61602	ABP000000811	N/A	Nov. 16, 2011	Sep. 29, 2012	Nov. 15, 2012	Conduction (CO01-KS)
System Simulator	R&S	CMU200	837587/066	2G Full-Band	Dec. 30, 2011	Sep. 29, 2012	Dec. 29, 2012	Conduction (CO01-KS)
EMI Test Receiver	R&S	ESCI	100534	9kHz~3GHz	Nov. 09, 2011	Oct. 08, 2012	Nov. 08, 2012	Radiation (03CH01-KS)
Spectrum Analyzer	R&S	FSP40	100319	9kHz~40GHz	Dec. 30, 2011	Oct. 08, 2012	Dec. 29, 2012	Radiation (03CH01-KS)
Bilog Antenna	SCHAFFNER	CBL6112D	23182	25MHz~2GHz	Dec. 08, 2011	Oct. 08, 2012	Dec. 07, 2012	Radiation (03CH01-KS)
Double Ridge Horn Antenna	EMCO	3117	00075959	1GHz~18GHz	Jan. 06, 2012	Oct. 08, 2012	Jan. 05, 2013	Radiation (03CH01-KS)
Amplifier	Wireless	FPA-6592G	060007	30MHz~2GHz	Dec. 30, 2011	Oct. 08, 2012	Dec. 29, 2012	Radiation (03CH01-KS)
Amplifier	Agilent	8449B	3008A02370	1GHz~26.5GHz	Dec. 30, 2011	Oct. 08, 2012	Dec. 29, 2012	Radiation (03CH01-KS)
Signal Generator	R&S	SMR40	100455	10MHz~40GHz	Dec. 30, 2011	Sep. 29, 2012~ Oct. 08, 2012	Dec. 29, 2012	-
System Simulator	R&S	CMU200	837587/066	2G Full-Band	Dec. 30, 2011	Sep. 29, 2012~ Oct. 08, 2012	Dec. 29, 2012	-

5. Uncertainty of Evaluation

Uncertainty of Conducted Emission Measurement (150 KHz ~ 30 MHz)

Measuring Uncertainty for a Level of Confidence of 95% ($U = 2Uc(y)$)	2.26
---	------

Uncertainty of Radiated Emission Measurement (30 MHz ~ 1000 MHz)

Measuring Uncertainty for a Level of Confidence of 95% ($U = 2Uc(y)$)	2.54
---	------

Uncertainty of Radiated Emission Measurement (1 GHz ~ 40 GHz)

Measuring Uncertainty for a Level of Confidence of 95% ($U = 2Uc(y)$)	4.72
---	------



Appendix A. Photographs of EUT

Please refer to Sporton report number EP291206 as below.