



FCC RF Test Report

APPLICANT : Brightstar Corporation
EQUIPMENT : Mobile Phone
BRAND NAME : Avvio
MODEL NAME : Avvio L800S, Avvio L800
FCC ID : WVBAL800X
STANDARD : FCC Part 15 Subpart C §15.247
CLASSIFICATION : (DTS) Digital Transmission System

The product was received on Aug. 05, 2015 and testing was completed on Sep. 08, 2015. We, SPORTON INTERNATIONAL (SHENZHEN) INC., would like to declare that the tested sample has been evaluated in accordance with the test procedures and has been in compliance with the applicable technical standards.

The test results in this report apply exclusively to the tested model / sample. Without written approval of SPORTON INTERNATIONAL (SHENZHEN) INC., the test report shall not be reproduced except in full.

Reviewed by: Joseph Lin / Supervisor

Approved by: Jones Tsai / Manager



SPORTON INTERNATIONAL (SHENZHEN) INC.

**1F & 2F, Building A, Morning Business Center, No. 4003 ShiGu Rd., Xili Town,
Nanshan District, Shenzhen, Guangdong, P. R. China**



TABLE OF CONTENTS

- 1 GENERAL DESCRIPTION 5**
 - 1.1 Applicant 5
 - 1.2 Manufacturer 5
 - 1.3 Product Feature of Equipment Under Test 5
 - 1.4 Product Specification subjective to this standard 6
 - 1.5 Modification of EUT 6
 - 1.6 Testing Location 7
 - 1.7 Applicable Standards 8
- 2 TEST CONFIGURATION OF EQUIPMENT UNDER TEST 9**
 - 2.1 Carrier Frequency Channel 9
 - 2.2 Pre-Scanned RF Power 10
 - 2.3 Test Mode 11
 - 2.4 Connection Diagram of Test System 12
 - 2.5 Support Unit used in test configuration and system 13
 - 2.6 EUT Operation Test Setup 13
 - 2.7 Measurement Results Explanation Example 14
- 3 TEST RESULT 15**
 - 3.1 6dB Bandwidth Measurement 15
 - 3.2 Output Power Measurement 17
 - 3.3 Power Spectral Density Measurement 19
 - 3.4 Conducted Band Edges and Spurious Emission Measurement 21
 - 3.5 Radiated Band Edges and Spurious Emission Measurement 34
 - 3.6 AC Conducted Emission Measurement 38
 - 3.7 Antenna Requirements 42
- 4 LIST OF MEASURING EQUIPMENT 43**
- 5 UNCERTAINTY OF EVALUATION 44**
- APPENDIX A. CONDUCTED TEST RESULTS**
- APPENDIX B. RADIATED TEST RESULTS**
- APPENDIX C. SETUP PHOTOGRAPHS**



REVISION HISTORY

REPORT NO.	VERSION	DESCRIPTION	ISSUED DATE
FR580514C	Rev. 01	Initial issue of report	Sep. 15, 2015



SUMMARY OF TEST RESULT

Report Section	FCC Rule	Description	Limit	Result	Remark
3.1	15.247(a)(2)	6dB Bandwidth	$\geq 0.5\text{MHz}$	Pass	-
3.2	15.247(b)	Power Output Measurement	$\leq 30\text{dBm}$	Pass	-
3.3	15.247(e)	Power Spectral Density	$\leq 8\text{dBm}/3\text{kHz}$	Pass	-
3.4	15.247(d)	Conducted Band Edges	$\leq 20\text{dBc}$	Pass	-
		Conducted Spurious Emission		Pass	-
3.5	15.247(d)	Radiated Band Edges and Radiated Spurious Emission	15.209(a) & 15.247(d)	Pass	Under limit 9.39 dB at 53.280 MHz
3.6	15.207	AC Conducted Emission	15.207(a)	Pass	Under limit 6.11 dB at 0.410 MHz
3.7	15.203 & 15.247(b)	Antenna Requirement	N/A	Pass	-



1 General Description

1.1 Applicant

Brightstar Corporation

9725 NW 117th Ave., Miami, Florida, FL 33178, United States

1.2 Manufacturer

Heng Da Chuang Xin Technology Limited

Rm14H Taibang Building, 4 Rd. High Tech South, Nanshan, SZ, P. R. C. 518000

1.3 Product Feature of Equipment Under Test

Product Feature	
Equipment	Mobile Phone
Brand Name	Avvio
Model Name	Avvio L800S, Avvio L800
FCC ID	WVVAL800X
EUT supports Radios application	GSM/GPRS/EGPRS/WCDMA/HSPA/HSPA+/DC-HSDPA/LTE/ WLAN2.4GHz 802.11b/g/n HT20/HT40/ Bluetooth v3.0+EDR/Bluetooth v4.0 LE
IMEI Code	Conducted: 358151060000352 Conduction: 358151060000311 Radiation: 358151060000345
HW Version	M326B
SW Version	AVVIO_L800_V1_0_1
EUT Stage	Production Unit

Remark:

1. The above EUT's information was declared by manufacturer. Please refer to the specifications or user's manual for more detailed description.
2. The difference of the two samples (Model Name: Avvio L800S, Avvio L800): Avvio L800 is single SIM card, Avvio L800S is dual SIM card. We only choose dual SIM sample to perform full tests.



1.4 Product Specification subjective to this standard

Product Specification subjective to this standard	
Tx/Rx Channel Frequency Range	802.11b/g/n : 2412 MHz ~ 2462 MHz
Maximum (Peak) Output Power to Antenna	802.11b : 16.88 dBm (0.0488 W) 802.11g : 18.90 dBm (0.0776 W) 802.11n HT20 : 19.23 dBm (0.0838 W) 802.11n HT40 : 20.65 dBm (0.1161 W)
Antenna Type/Gain	802.11b/g/n : PIFA Antenna with gain -1.00 dBi
Type of Modulation	802.11b : DSSS (DBPSK / DQPSK / CCK) 802.11g/n : OFDM (BPSK / QPSK / 16QAM / 64QAM)

1.5 Modification of EUT

No modifications are made to the EUT during all test items.



1.6 Testing Location

Test Site	SPORTON INTERNATIONAL (SHENZHEN) INC.	
Test Site Location	1F & 2F, Building A, Morning Business Center, No. 4003 ShiGu Rd., Xili Town, Nanshan District, Shenzhen, Guangdong, P. R. China TEL: +86-755-8637-9589 FAX: +86-755-8637-9595	
Test Site No.	Sporton Site No.	
	TH01-SZ	CO01-SZ

Test Site	SPORTON INTERNATIONAL (SHENZHEN) INC.	
Test Site Location	No. 3 Building, the third floor of south, Shahe River west, Fengzeyuan warehouse, Nanshan District, Shenzhen, Guangdong, P. R. China TEL: +86-755- 3320-2398	
Test Site No.	Sporton Site No.	FCC Registration No.
	03CH02-SZ	566869

Note: The test site complies with ANSI C63.4 2009 requirement.



1.7 Applicable Standards

According to the specifications of the manufacturer, the EUT must comply with the requirements of the following standards:

- ♦ FCC Part 15 Subpart C §15.247
- ♦ FCC KDB Publication No. 558074 D01 DTS Meas. Guidance v03r03
- ♦ ANSI C63.10-2013

Remark:

1. All test items were verified and recorded according to the standards and without any deviation during the test.
2. FCC permits the use of the 1.5 meter table as an alternative in C63.10-2013 through inquiry tracking number 961829.
3. This EUT has also been tested and complied with the requirements of FCC Part 15, Subpart B, recorded in a separate test report.



2 Test Configuration of Equipment Under Test

The EUT has been associated with peripherals and configuration operated in a manner tended to maximize its emission characteristics in a typical application. Frequency range investigated: conducted emission (150 kHz to 30 MHz) and radiated emission (9 kHz to the 10th harmonic of the highest fundamental frequency or to 40 GHz, whichever is lower). For radiated measurement, pre-scanned in three orthogonal panels, X, Y, Z. The worst cases (Z plane) were recorded in this report.

The final configuration from all the combinations and the worst-case data rates were investigated by measuring the maximum power across all the data rates and modulation modes under section 2.2.

Based on the worst configuration found above, the RF power setting is set individually to meet FCC compliance limit for the final conducted and radiated tests shown in section 2.3.

2.1 Carrier Frequency Channel

Frequency Band	Channel	Freq. (MHz)	Channel	Freq. (MHz)
2400-2483.5 MHz	1	2412	7	2442
	2	2417	8	2447
	3	2422	9	2452
	4	2427	10	2457
	5	2432	11	2462
	6	2437	-	-



2.2 Pre-Scanned RF Power

Preliminary tests were performed in different data rate and data rate associated with the highest power were chosen for full test shown in the following tables.

2.4GHz 802.11b RF Output Power (dBm)						
Power vs. Channel			Power vs. Data Rate			
Channel	Frequency (MHz)	Data Rate	Channel	2Mbps	5.5Mbps	11Mbps
		1Mbps				
CH 01	2412 MHz	16.88	CH 01	16.86	16.45	16.81
CH 06	2437 MHz	16.09				
CH 11	2462 MHz	15.36				

2.4GHz 802.11g RF Output Power (dBm)										
Power vs. Channel			Power vs. Data Rate							
Channel	Frequency (MHz)	Data Rate	Channel	9Mbps	12Mbps	18Mbps	24Mbps	36Mbps	48Mbps	54Mbps
		6Mbps								
CH 01	2412 MHz	18.78	CH 06	18.87	18.85	18.85	18.70	18.67	18.78	18.75
CH 06	2437 MHz	18.90								
CH 11	2462 MHz	17.97								

2.4GHz 802.11n HT20 RF Output Power (dBm)										
Power vs. Channel			Power vs. MCS Index							
Channel	Frequency (MHz)	MCS Index	Channel	MCS1	MCS2	MCS3	MCS4	MCS5	MCS6	MCS7
		MCS0								
CH 01	2412 MHz	19.16	CH 06	18.78	19.10	18.78	18.96	19.13	19.19	19.20
CH 06	2437 MHz	19.23								
CH 11	2462 MHz	17.49								

2.4GHz 802.11n HT40 RF Output Power (dBm)										
Power vs. Channel			Power vs. MCS Index							
Channel	Frequency (MHz)	MCS Index	Channel	MCS1	MCS2	MCS3	MCS4	MCS5	MCS6	MCS7
		MCS0								
CH 03	2422 MHz	18.79	CH 06	19.31	19.48	19.08	19.21	20.20	20.27	20.48
CH 06	2437 MHz	20.65								
CH 09	2452 MHz	17.42								



2.3 Test Mode

Final test mode of conducted test items and radiated spurious emissions are considering the modulation and worse data rates from the power table described in section 2.2.

<2.4GHz>

Modulation	Data Rate
802.11b	1 Mbps
802.11g	6 Mbps
802.11n HT20	MCS0
802.11n HT40	MCS0

Test Cases	
AC Conducted Emission	Mode 1: GSM850 Idle + Bluetooth Link + WLAN Link(2.4G) + Earphone + USB Cable (Charging from Adapter)
Remark: For Radiated Test Cases, The tests were performance with Adapter, Earphone and USB Cable.	

2.4 Connection Diagram of Test System

<WLAN Tx Mode>

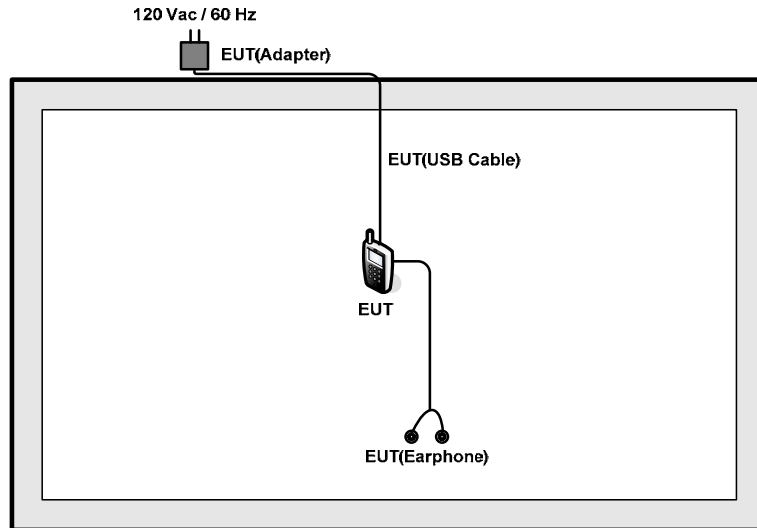

<AC Conducted Emission Mode>

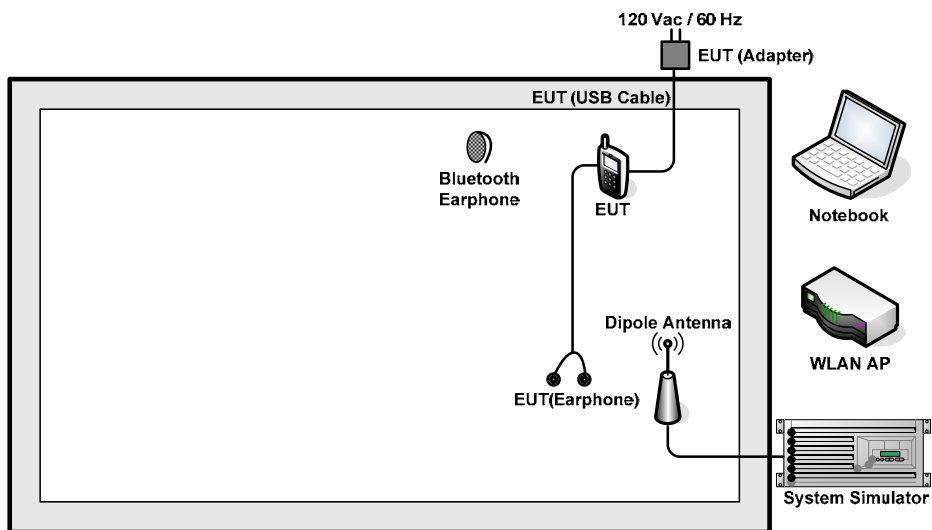



2.5 Support Unit used in test configuration and system

Item	Equipment	Trade Name	Model Name	FCC ID	Data Cable	Power Cord
1.	System Simulator	Anritsu	MT8820C	N/A	N/A	Unshielded, 1.8 m
2.	WLAN AP	D-link	DIR-628	KA2DIR628A2	N/A	Unshielded, 1.8 m
3.	Notebook	Lenovo	E540	FCC DoC	N/A	AC I/P: Unshielded, 1.2 m DC O/P: Shielded, 1.8 m
4.	Bluetooth Earphone	Nokia	BH-108	PYAHS-107W	N/A	N/A

2.6 EUT Operation Test Setup

For WLAN RF test items, an engineering test program was provided and enabled to make EUT continuously transmit/receive.

For AC power line conducted emissions, the EUT was set to connect with the WLAN AP under large package sizes transmission.



2.7 Measurement Results Explanation Example

For all conducted test items:

The offset level is set in the spectrum analyzer to compensate the RF cable loss and attenuator factor between EUT conducted output port and spectrum analyzer. With the offset compensation, the spectrum analyzer reading level is exactly the EUT RF output level.

Example :

The spectrum analyzer offset is derived from RF cable loss and attenuator factor.

Offset = RF cable loss + attenuator factor.

Following shows an offset computation example with cable loss 5.0 dB and 10dB attenuator.

$$\begin{aligned} \text{Offset(dB)} &= \text{RF cable loss(dB)} + \text{attenuator factor(dB)}. \\ &= 5.0 + 10 = 15.0 \text{ (dB)} \end{aligned}$$

3 Test Result

3.1 6dB Bandwidth Measurement

3.1.1 Limit of 6dB Bandwidth

The minimum 6 dB bandwidth shall be at least 500 kHz.

3.1.2 Measuring Instruments

The measuring equipment is listed in the section 4 of this test report.

3.1.3 Test Procedures

1. The testing follows FCC KDB Publication No. 558074 DTS D01 Meas. Guidance v03r03.
2. The RF output of EUT was connected to the spectrum analyzer by RF cable and attenuator. The path loss was compensated to the results for each measurement.
3. Set to the maximum power setting and enable the EUT transmit continuously.
4. Make the measurement with the spectrum analyzer's resolution bandwidth (RBW) = 100 kHz. Set the Video bandwidth (VBW) = 300 kHz. In order to make an accurate measurement. The 6 dB bandwidth must be greater than 500 kHz.
5. Measure and record the results in the test report.

3.1.4 Test Setup

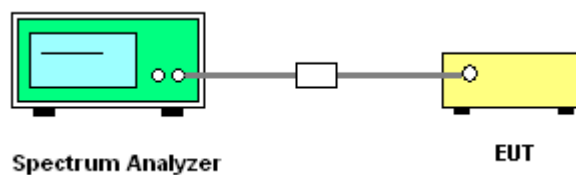

3.1.5 Test Result of 6dB Occupied Bandwidth

Please refer to Appendix A of this test report.

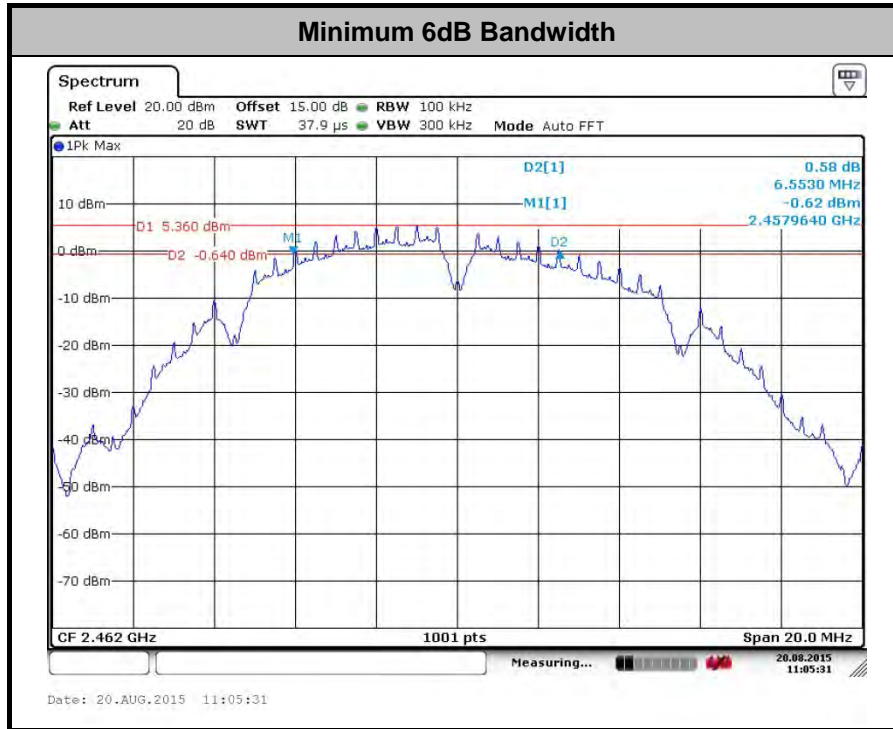

Note : The occupied channel bandwidth is maintained within the band of operation for all of the modulations.

3.2 Output Power Measurement

3.2.1 Limit of Output Power

For systems using digital modulation in the 2400-2483.5MHz, the limit for peak output power is 30dBm. If transmitting Antenna of directional gain greater than 6dBi are used the peak output power from the intentional radiator shall be reduced below the above stated value by the amount in dB that the directional gain of the Antenna exceeds 6 dBi. In case of point-to-point operation, the limit has to be reduced by 1dB for every 3dB that the directional gain of the Antenna exceeds 6dBi.

3.2.2 Measuring Instruments

The measuring equipment is listed in the section 4 of this test report.

3.2.3 Test Procedures

1. The testing follows the Measurement Procedure of FCC KDB No. 558074 DTS D01 Meas. Guidance v03r03 section 9.1.2 PKPM1 Peak power meter method.
2. The RF output of EUT was connected to the power meter by RF cable and attenuator. The path loss was compensated to the results for each measurement.
3. Set to the maximum power setting and enable the EUT transmit continuously.
4. Measure the conducted output power and record the results in the test report.

3.2.4 Test Setup

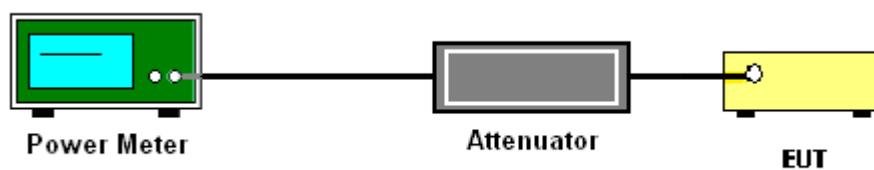



3.2.5 Test Result of Peak Output Power

Please refer to Appendix A of this test report.

3.2.6 Test Result of Average output Power (Reporting Only)

Please refer to Appendix A of this test report.

3.3 Power Spectral Density Measurement

3.3.1 Limit of Power Spectral Density

The peak power spectral density shall not be greater than 8dBm in any 3kHz band at any time interval of continuous transmission.

3.3.2 Measuring Instruments

The measuring equipment is listed in the section 4 of this test report.

3.3.3 Test Procedures

1. The testing follows Measurement Procedure 10.2 Method PKPSD of FCC KDB Publication No. 558074 D01 DTS Meas. Guidance v03r03
2. The RF output of EUT was connected to the spectrum analyzer by RF cable and attenuator. The path loss was compensated to the results for each measurement.
3. Set to the maximum power setting and enable the EUT transmit continuously.
4. Make the measurement with the spectrum analyzer's resolution bandwidth (RBW) = 3 kHz. Video bandwidth VBW = 10 kHz In order to make an accurate measurement, set the span to 1.5 times DTS Channel Bandwidth. (6dB BW)
5. Detector = peak, Sweep time = auto couple, Trace mode = max hold, Allow trace to fully stabilize. Use the peak marker function to determine the maximum power level.
6. Measure and record the results in the test report.

3.3.4 Test Setup

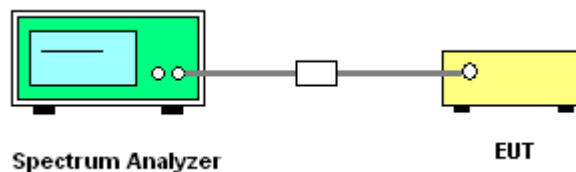



3.3.5 Test Result of Power Spectral Density

Please refer to Appendix A of this test report.

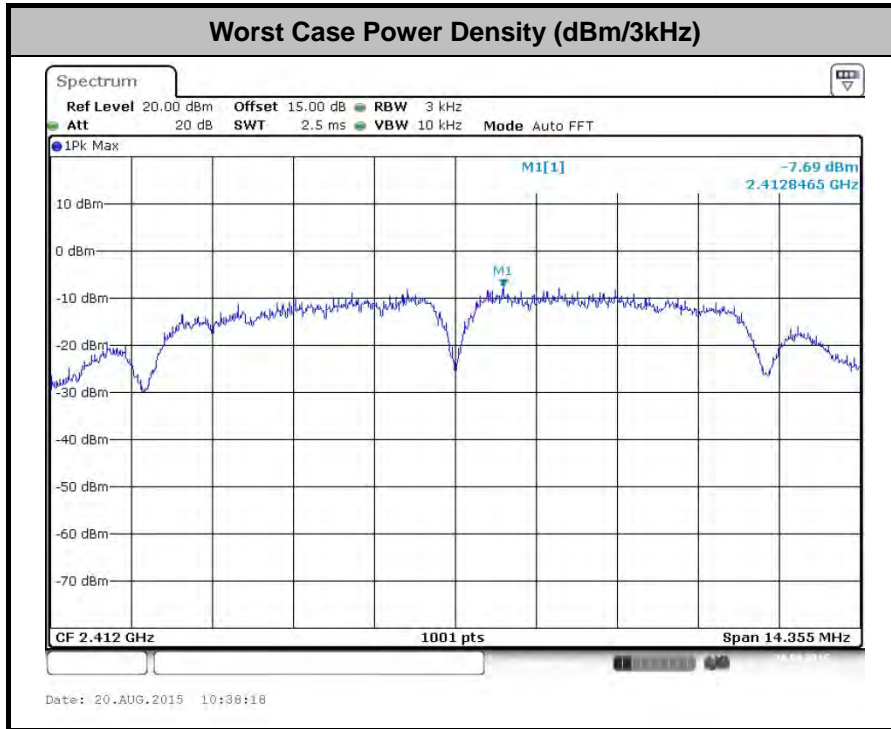

3.4 Conducted Band Edges and Spurious Emission Measurement

3.4.1 Limit of Conducted Band Edges and Spurious Emission Measurement

In any 100 kHz bandwidth outside of the authorized frequency band, the emissions which fall in the non-restricted bands shall be attenuated at least 20 dB / 30dB relative to the maximum PSD level in 100 kHz by RF conducted measurement and radiated emissions which fall in the restricted bands, as defined in Section 15.205(a), must also comply with the radiated emission limits specified in Section 15.209(a).

3.4.2 Measuring Instruments

The measuring equipment is listed in the section 4 of this test report.

3.4.3 Test Procedures

1. The testing follows FCC KDB Publication No. 558074 D01 DTS Meas. Guidance v03r03.
2. The RF output of EUT was connected to the spectrum analyzer by RF cable and attenuator. The path loss was compensated to the results for each measurement.
3. Set to the maximum power setting and enable the EUT transmit continuously.
4. Set RBW = 100 kHz, VBW=300 kHz, Peak Detector. Unwanted Emissions measured in any 100 kHz bandwidth outside of the authorized frequency band shall be attenuated by at least 20 dB relative to the maximum in-band peak PSD level in 100 kHz when maximum peak conducted output power procedure is used. If the transmitter complies with the conducted power limits based on the use of RMS averaging over a time interval, the attenuation required under this paragraph shall be 30 dB instead of 20 dB per 15.247(d).
5. Measure and record the results in the test report.
6. The RF fundamental frequency should be excluded against the limit line in the operating frequency band.

3.4.4 Test Setup

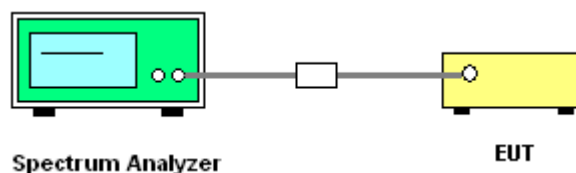



3.4.5 Test Result of Conducted Band Edges and Spurious Emission

Test Mode :	802.11b	Temperature :	21~25°C
Test Band :	2.4GHz Low	Relative Humidity :	51~54%
Test Channel :	01	Test Engineer :	Mygai Wang

WLAN 802.11b Channel 01

100kHz PSD reference Level

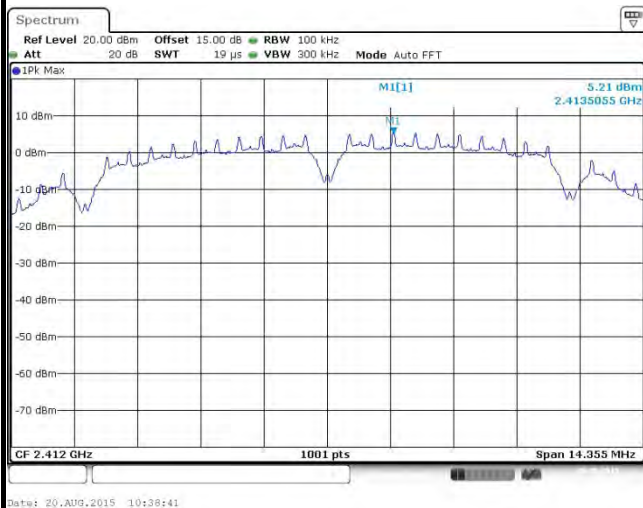

Low Channel Plot

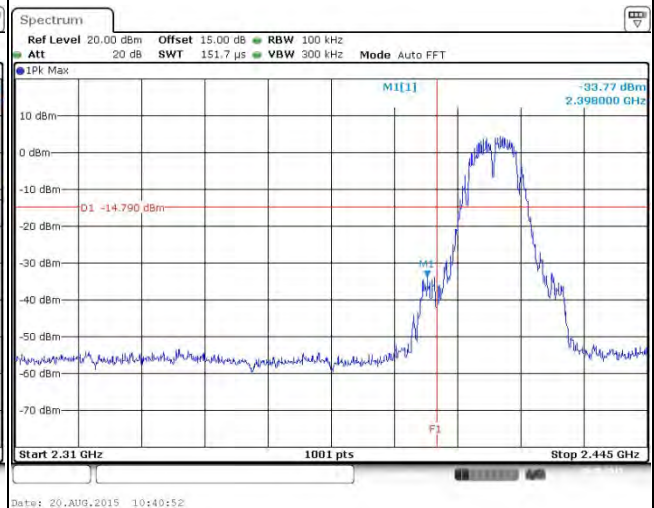

Spurious Emission 30MHz~3GHz

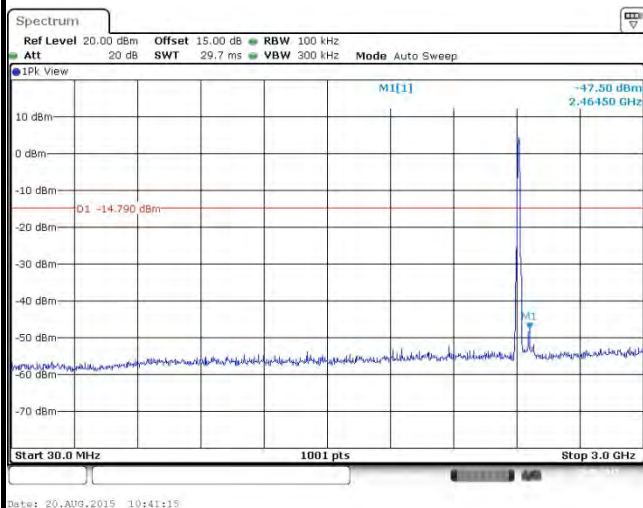

Spurious Emission 2GHz~25GHz

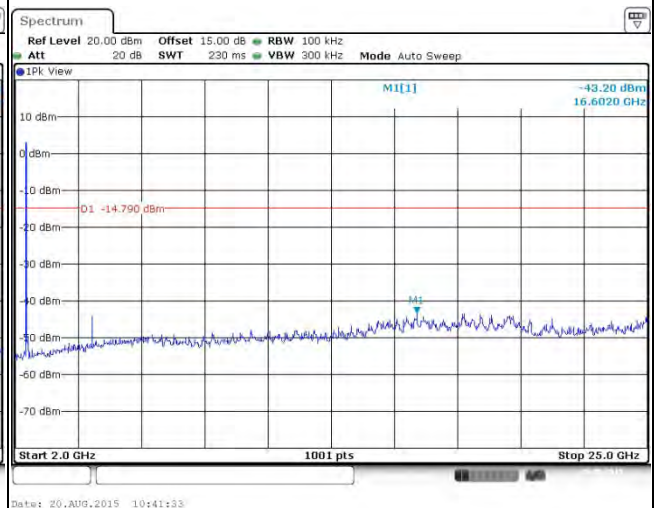



Test Mode :	802.11b	Temperature :	21~25°C
Test Band :	2.4GHz Mid	Relative Humidity :	51~54%
Test Channel :	06	Test Engineer :	Mygai Wang

WLAN 802.11b Channel 06

100kHz PSD reference Level

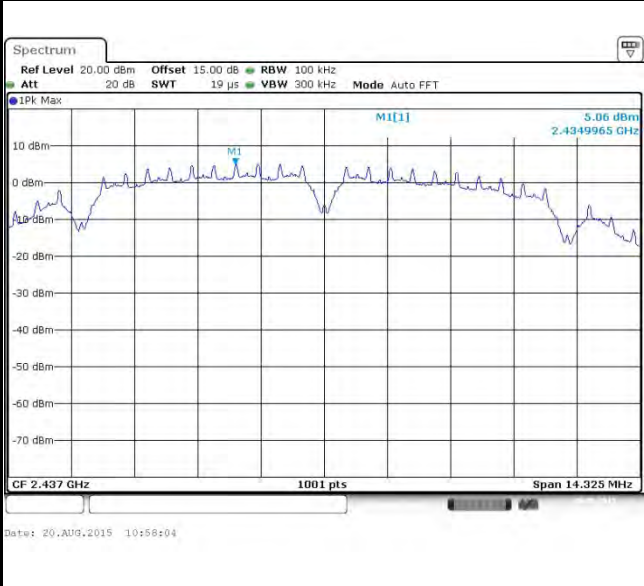

Spurious Emission 30MHz~3GHz

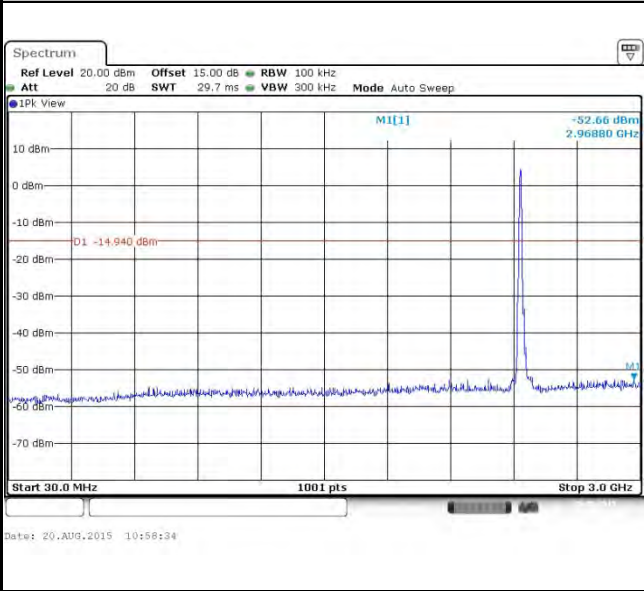

Spurious Emission 2GHz~25GHz

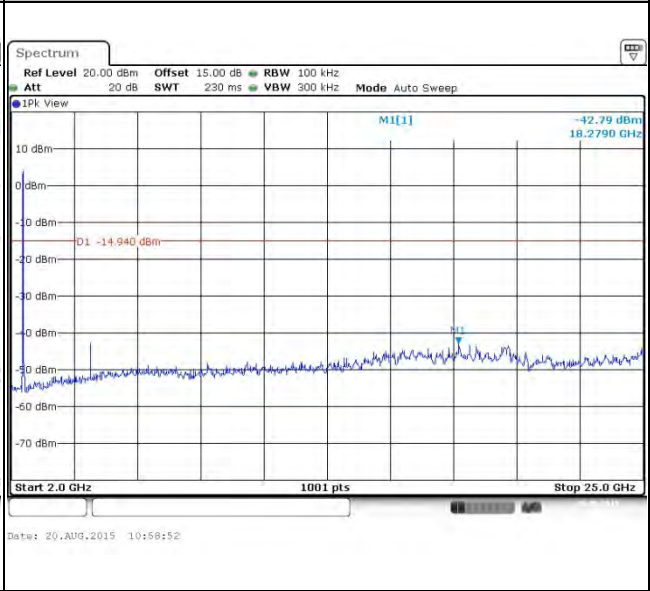



Test Mode :	802.11b	Temperature :	21~25°C
Test Band :	2.4GHz High	Relative Humidity :	51~54%
Test Channel :	11	Test Engineer :	Mygai Wang

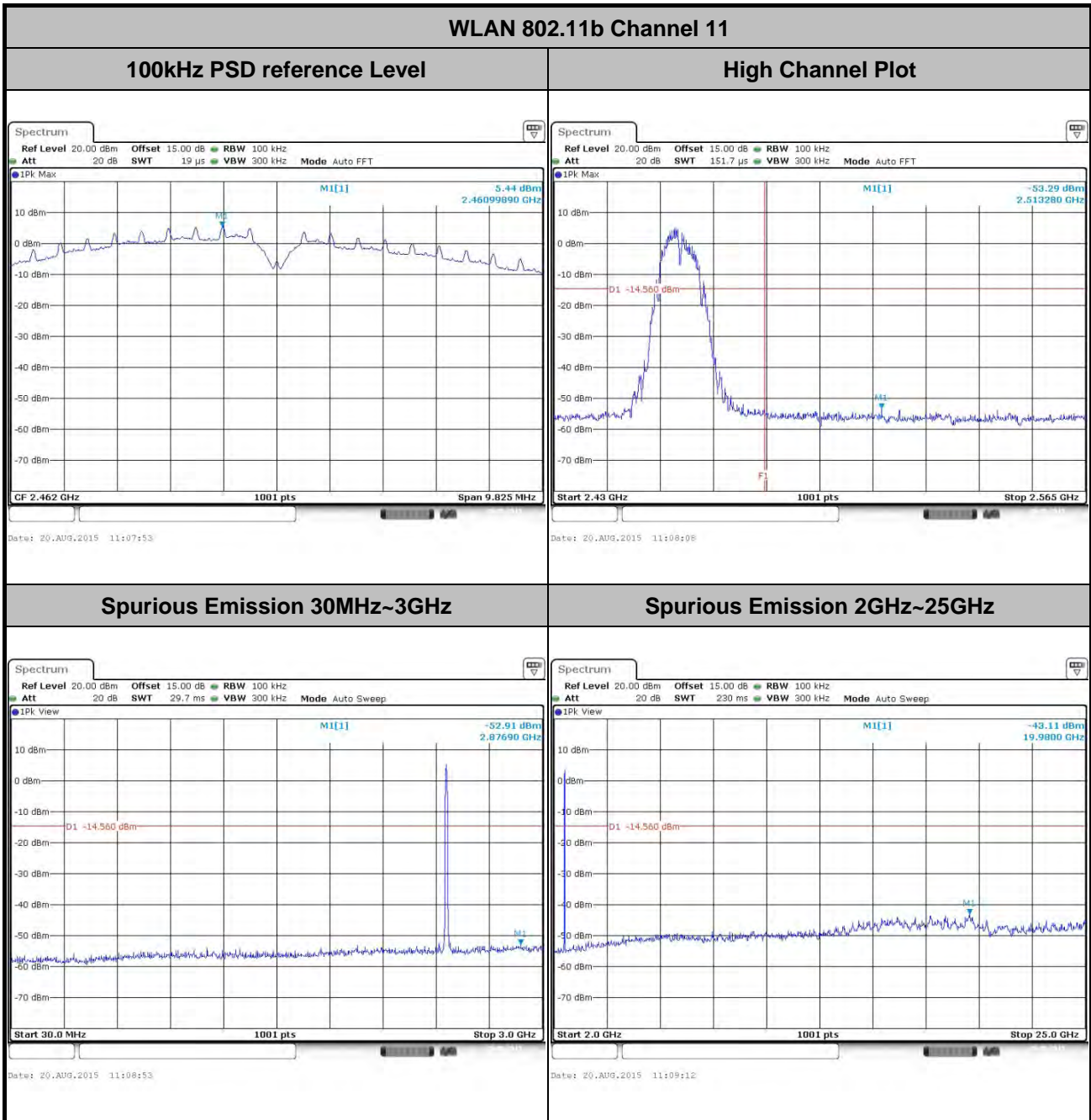



Test Mode :	802.11g	Temperature :	21~25°C
Test Band :	2.4GHz Low	Relative Humidity :	51~54%
Test Channel :	01	Test Engineer :	Mygai Wang

WLAN 802.11g Channel 01

100kHz PSD reference Level

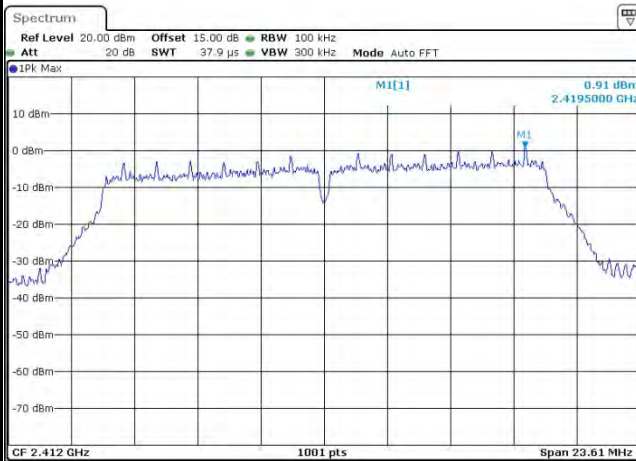

Date: 20.AUG.2015 11:20:25

Low Channel Plot

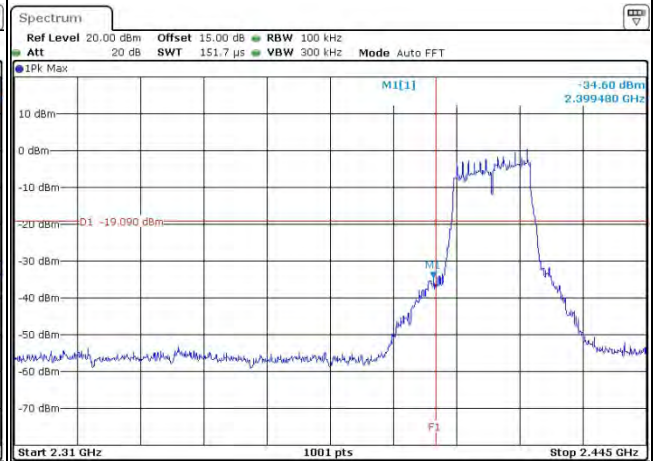

Date: 20.AUG.2015 11:21:09

Spurious Emission 30MHz~3GHz

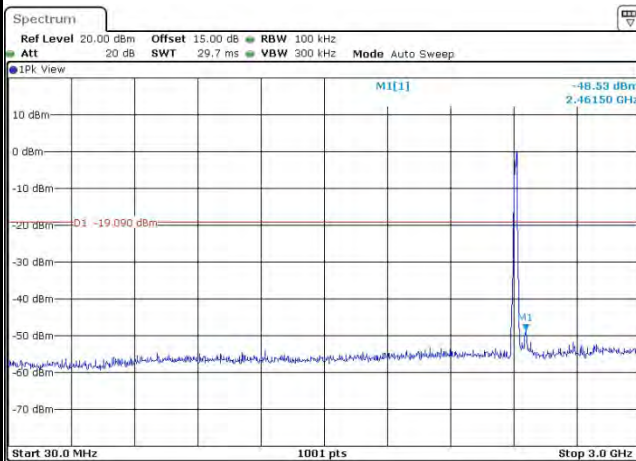

Date: 20.AUG.2015 11:21:44

Spurious Emission 2GHz~25GHz

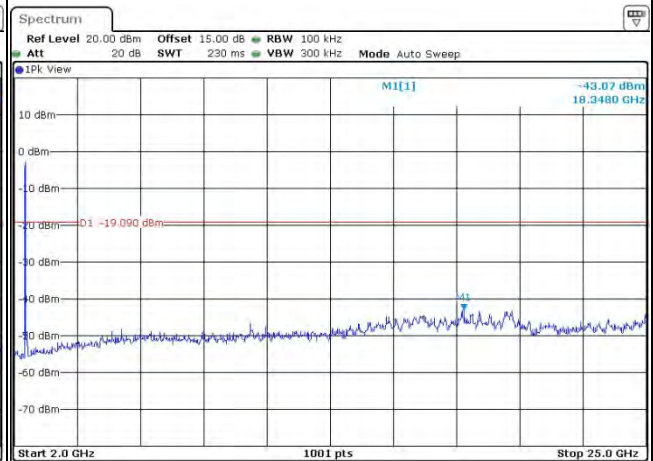

Date: 20.AUG.2015 11:22:02



Test Mode :	802.11g	Temperature :	21~25°C
Test Band :	2.4GHz Mid	Relative Humidity :	51~54%
Test Channel :	06	Test Engineer :	Mygai Wang

WLAN 802.11g Channel 06

100kHz PSD reference Level

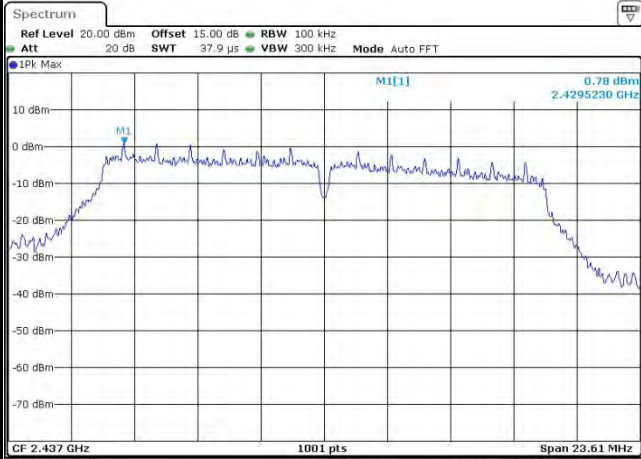

Date: 20.AUG.2015 11:42:27

Spurious Emission 30MHz~3GHz

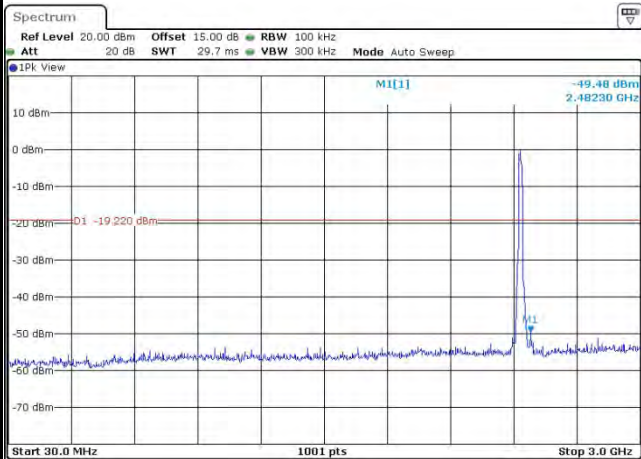

Date: 20.AUG.2015 11:42:46

Spurious Emission 2GHz~25GHz

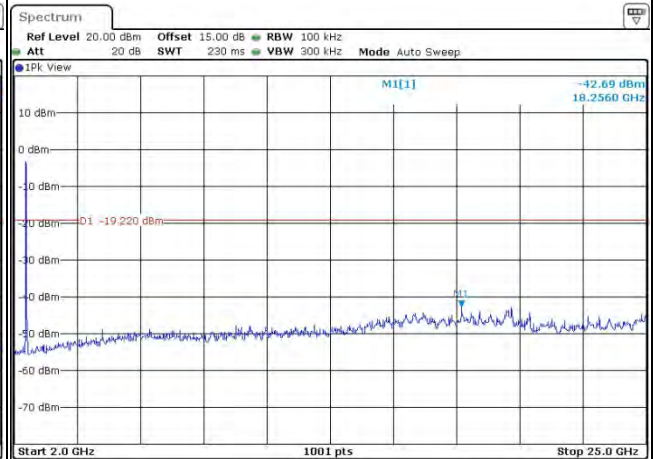

Date: 20.AUG.2015 11:43:04



Test Mode :	802.11g	Temperature :	21~25°C
Test Band :	2.4GHz High	Relative Humidity :	51~54%
Test Channel :	11	Test Engineer :	Mygai Wang

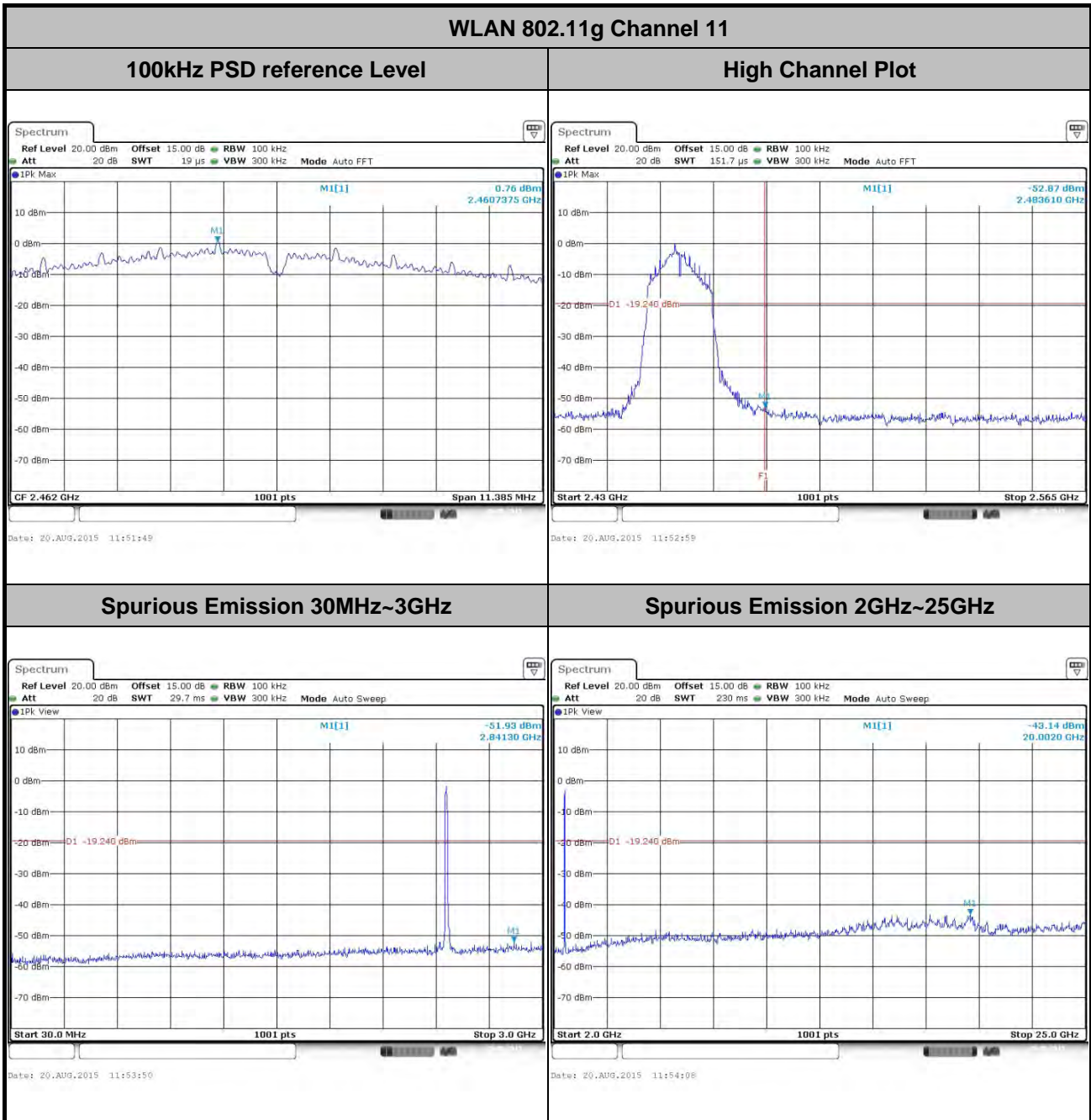



Test Mode :	802.11n HT20	Temperature :	21~25°C
Test Band :	2.4GHz Low	Relative Humidity :	51~54%
Test Channel :	01	Test Engineer :	Mygai Wang

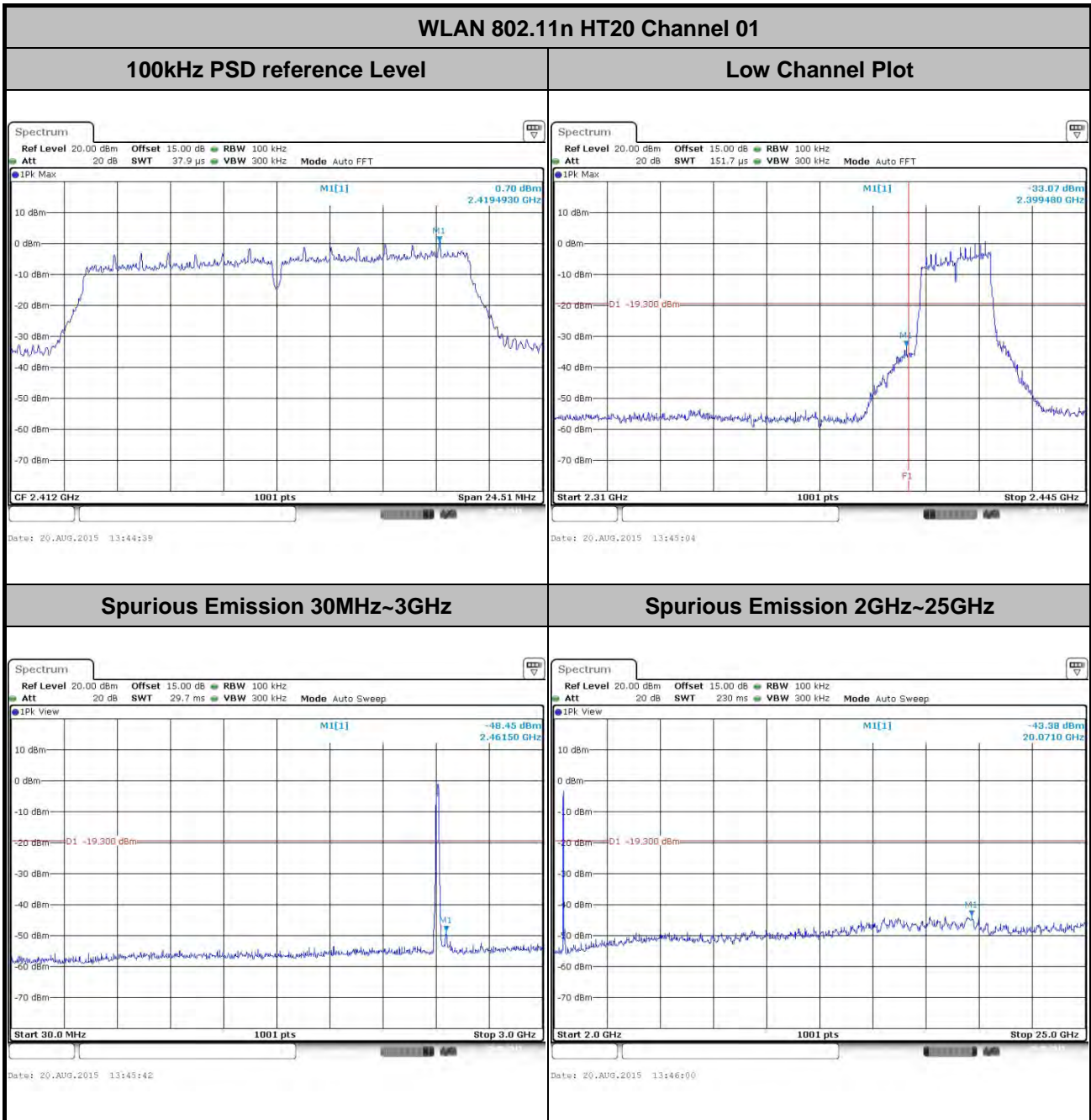



Test Mode :	802.11n HT20	Temperature :	21~25°C
Test Band :	2.4GHz Mid	Relative Humidity :	51~54%
Test Channel :	06	Test Engineer :	Mygai Wang

WLAN 802.11n HT20 Channel 06

100kHz PSD reference Level

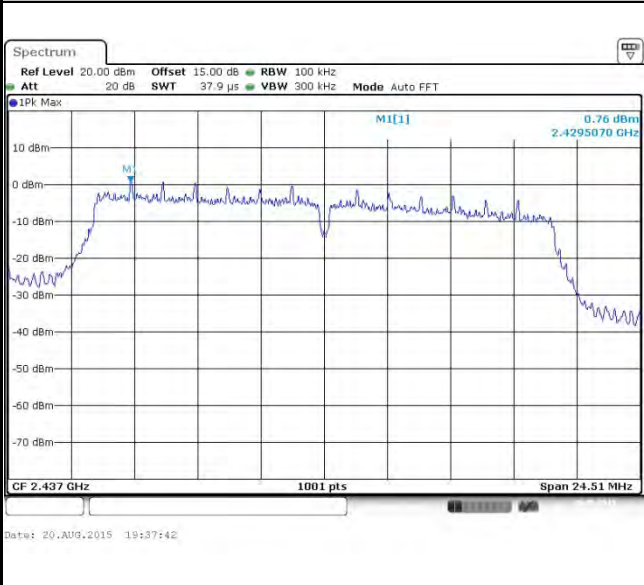

Spurious Emission 30MHz~3GHz

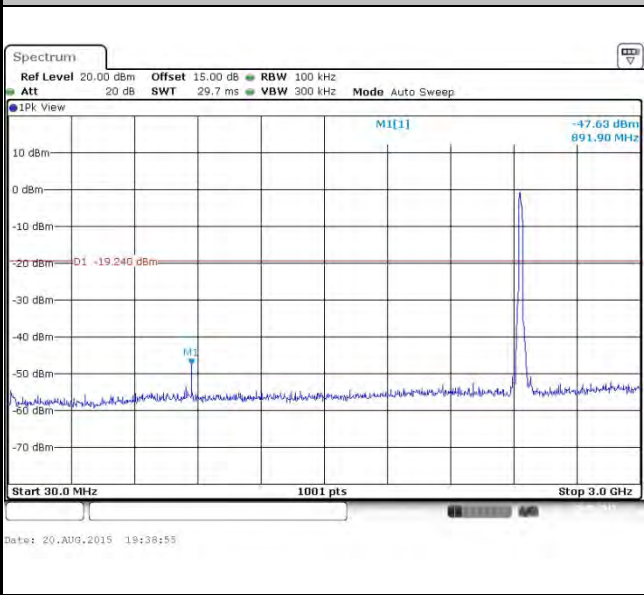

Spurious Emission 2GHz~25GHz

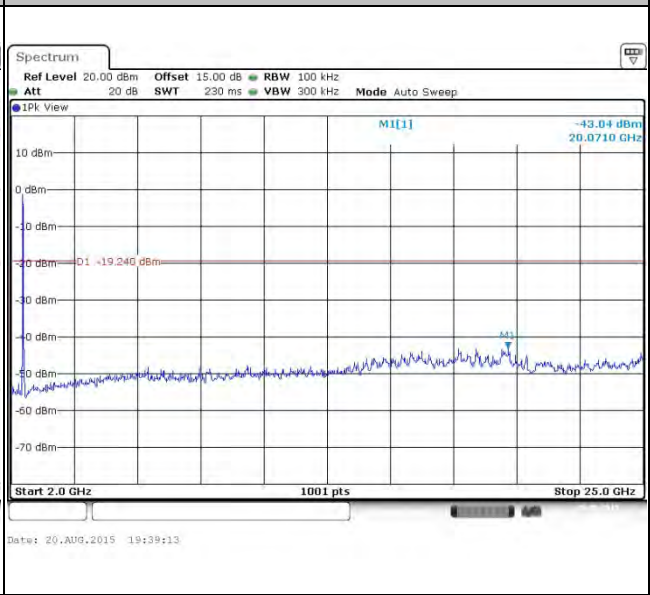



Test Mode :	802.11n HT20	Temperature :	21~25°C
Test Band :	2.4GHz High	Relative Humidity :	51~54%
Test Channel :	11	Test Engineer :	Mygai Wang

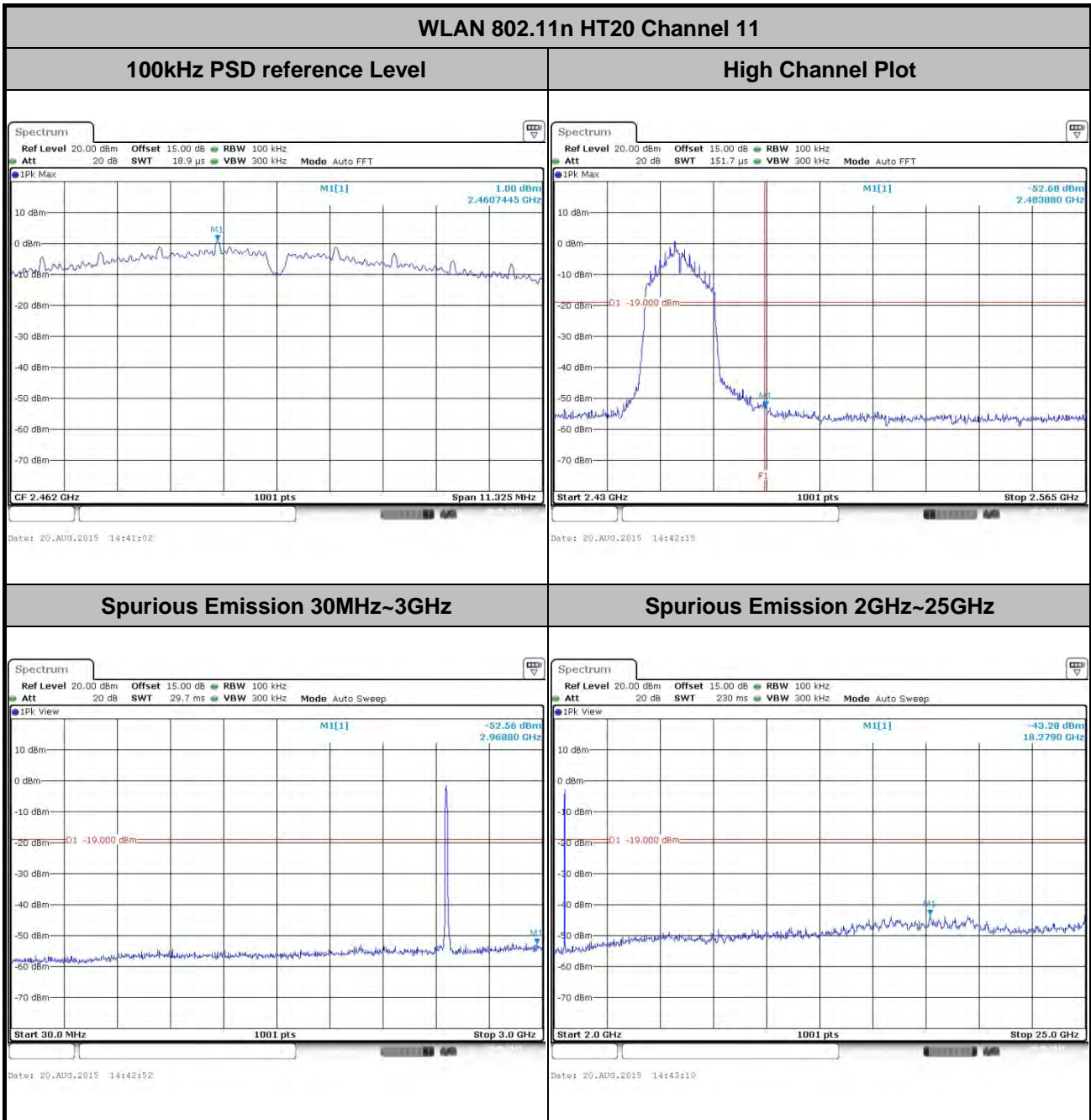



Test Mode :	802.11n HT40	Temperature :	21~25°C
Test Band :	2.4GHz Low	Relative Humidity :	51~54%
Test Channel :	03	Test Engineer :	Mygai Wang

WLAN 802.11n HT40 Channel 03

100kHz PSD reference Level

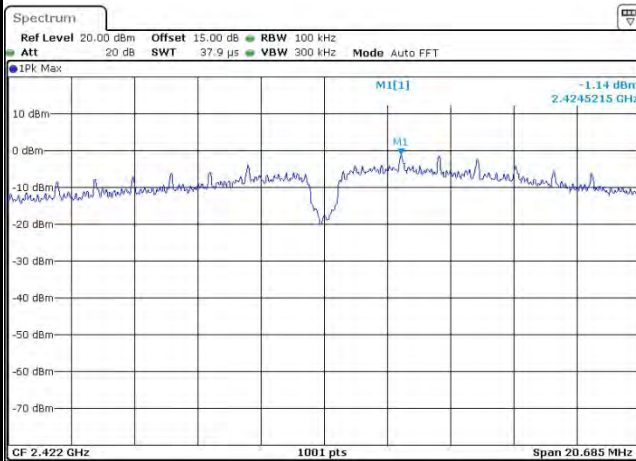

Date: 20.AUG.2015 22:29:44

Low Channel Plot

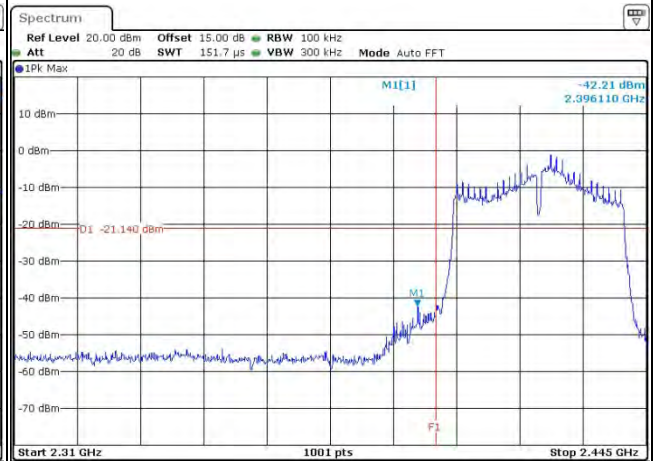

Date: 20.AUG.2015 22:30:01

Spurious Emission 30MHz~3GHz

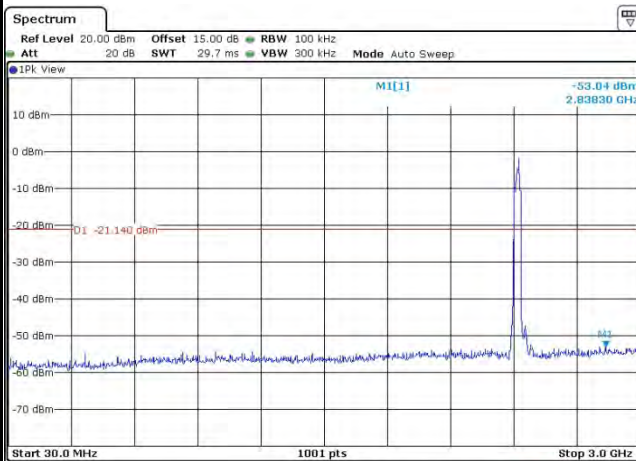

Date: 8,SEP.2015 15:19:04

Spurious Emission 2GHz~25GHz

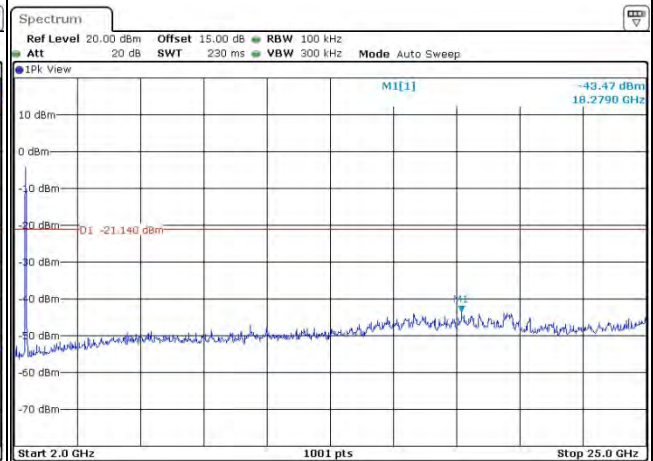

Date: 8,SEP.2015 15:17:11



Test Mode :	802.11n HT40	Temperature :	21~25°C
Test Band :	2.4GHz Mid	Relative Humidity :	51~54%
Test Channel :	06	Test Engineer :	Mygai Wang

WLAN 802.11n HT40 Channel 06

100kHz PSD reference Level

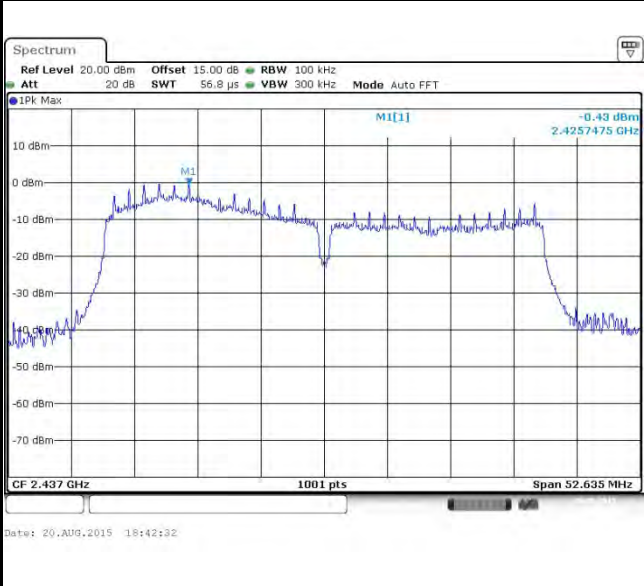

Spurious Emission 30MHz~3GHz

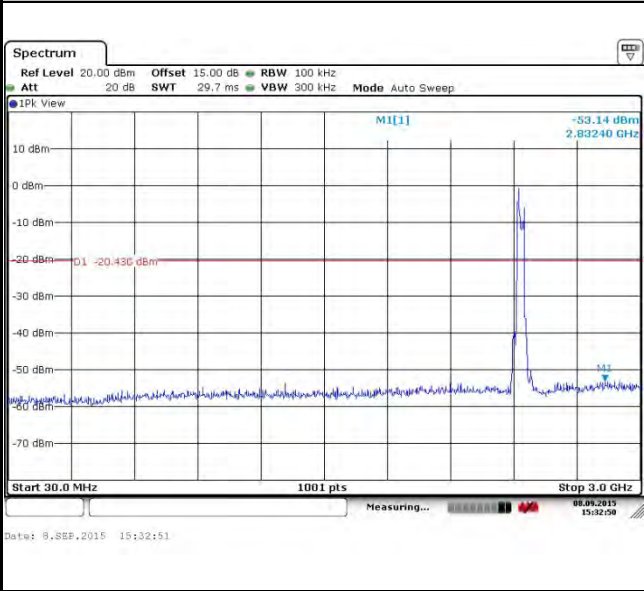

Spurious Emission 2GHz~25GHz

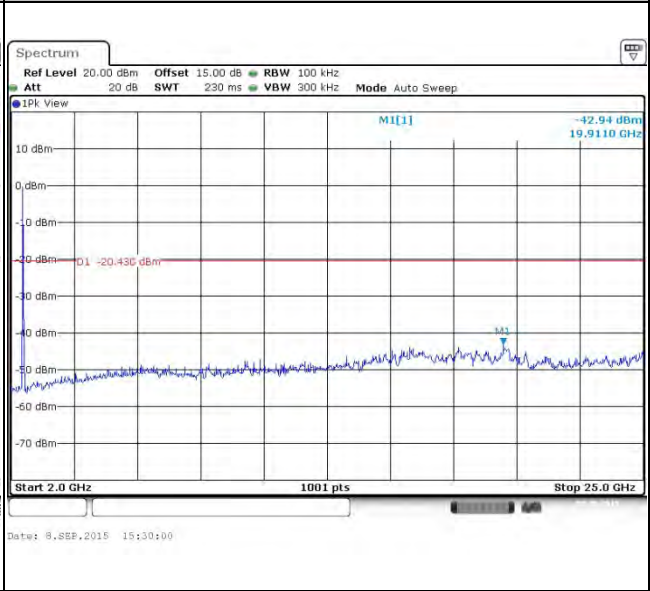



Test Mode :	802.11n HT40	Temperature :	21~25°C
Test Band :	2.4GHz High	Relative Humidity :	51~54%
Test Channel :	09	Test Engineer :	Mygai Wang

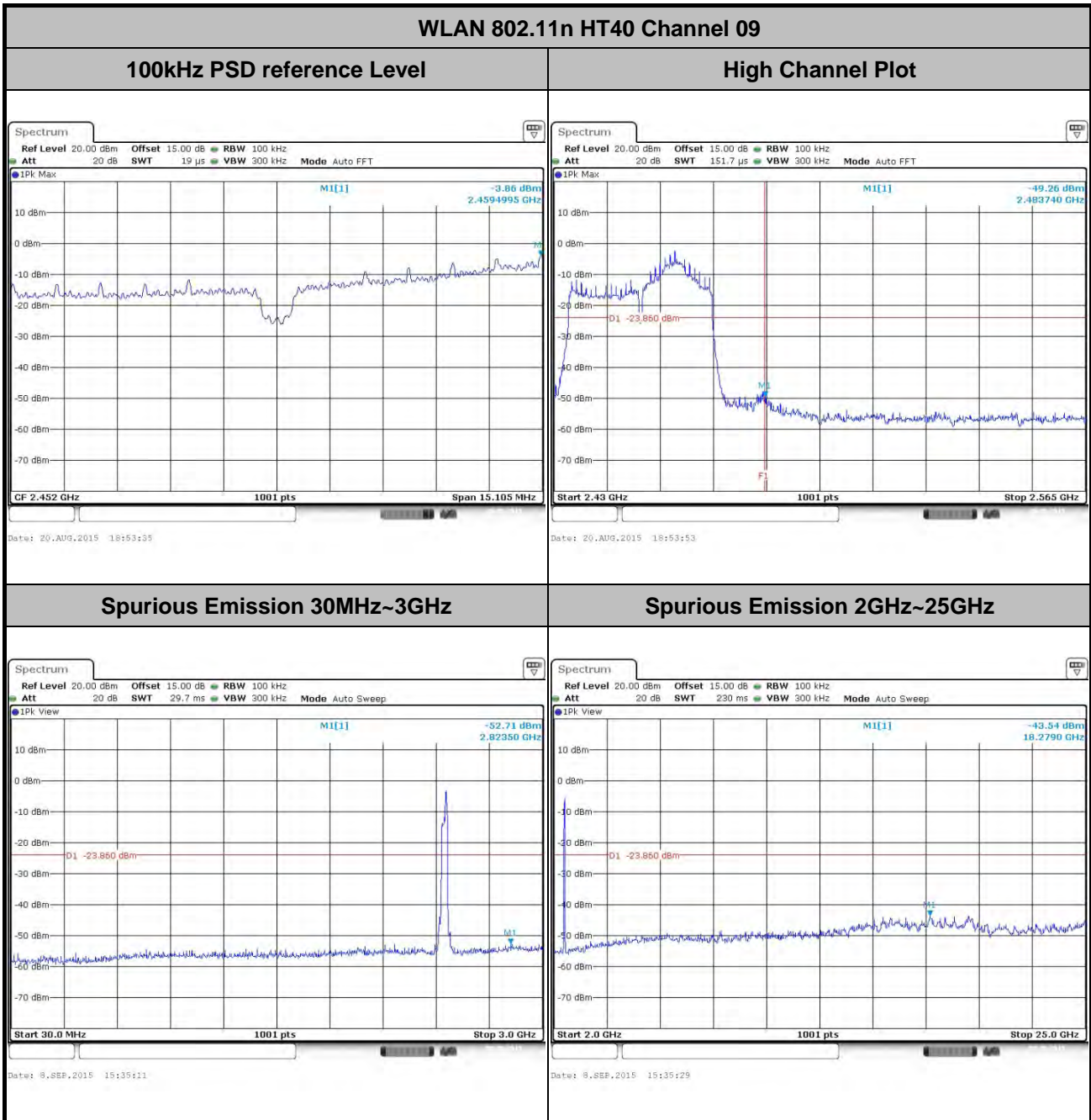



3.5 Radiated Band Edges and Spurious Emission Measurement

3.5.1 Limit of Radiated band edge and Spurious Emission Measurement

In any 100 kHz bandwidth outside the intentional radiator frequency band, all harmonics/spurious must be at least 20 dB below the highest emission level within the authorized band. If the output power of this device was measured by spectrum analyzer, the attenuation under this paragraph shall be 30 dB instead of 20 dB. In addition, radiated emissions which fall in the restricted bands must also comply with the FCC section 15.209 limits as below.

Frequency (MHz)	Field Strength (microvolts/meter)	Measurement Distance (meters)
0.009 – 0.490	2400/F(kHz)	300
0.490 – 1.705	24000/F(kHz)	30
1.705 – 30.0	30	30
30 – 88	100	3
88 – 216	150	3
216 - 960	200	3
Above 960	500	3

3.5.2 Measuring Instruments

The measuring equipment is listed in the section 4 of this test report.



3.5.3 Test Procedures

1. The testing follows FCC KDB Publication No. 558074 D01 DTS Meas. Guidance v03r03.
2. The EUT was arranged to its worst case and then tune the antenna tower (from 1 m to 4 m) and turntable (from 0 degree to 360 degrees) to find the maximum reading. A pre-amp and a high pass filter are used for the test in order to get better signal level.
3. The EUT was placed on a turntable with 0.8 meter for frequency below 1GHz and 1.5 meter for frequency above 1GHz respectively above ground.
4. The EUT was set 3 meters from the interference receiving antenna, which was mounted on the top of a variable height antenna tower.
5. Corrected Reading: Antenna Factor + Cable Loss + Read Level - Preamp Factor = Level
6. For measurement below 1GHz, If the emission level of the EUT measured by the peak detector is 3 dB lower than the applicable limit, the peak emission level will be reported. Otherwise, the emission measurement will be repeated using the quasi-peak detector and reported.
7. Use the following spectrum analyzer settings:
 - (1) Span shall wide enough to fully capture the emission being measured;
 - (2) Set RBW=100 kHz for $f < 1 \text{ GHz}$; $\text{VBW} \geq \text{RBW}$; Sweep = auto; Detector function = peak; Trace = max hold;
 - (3) Set RBW = 1 MHz, VBW= 3MHz for $f \geq 1 \text{ GHz}$ for peak measurement.

For average measurement:

 - $\text{VBW} = 10 \text{ Hz}$, when duty cycle is no less than 98 percent.
 - $\text{VBW} \geq 1/T$, when duty cycle is less than 98 percent where T is the minimum transmission duration over which the transmitter is on and is transmitting at its maximum power control level for the tested mode of operation.

Band	Duty Cycle(%)	T(ms)	1/T(kHz)	VBW Setting
802.11b	97.97	8.38	0.12	300Hz
802.11g	88.91	1.39	0.72	1kHz
2.4GHz 802.11n HT20	88.21	1.30	0.77	1kHz
2.4GHz 802.11n HT40	79.15	0.65	1.54	3kHz

3.5.4 Test Setup

For radiated emissions below 30MHz

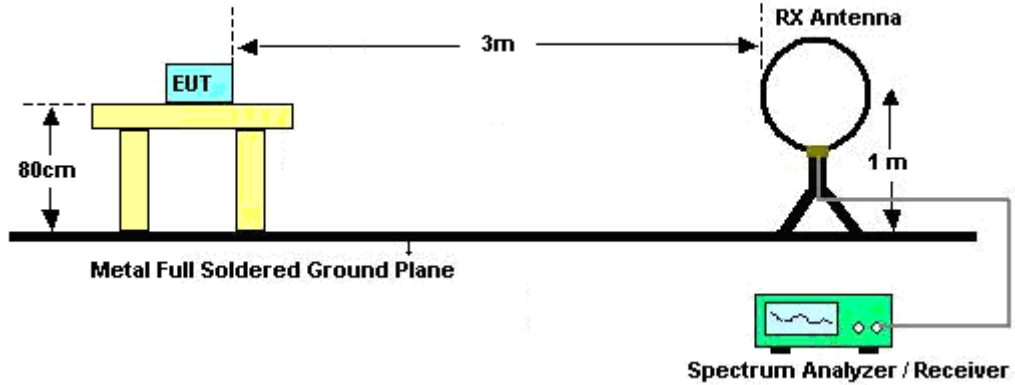

For radiated emissions from 30MHz to 1GHz

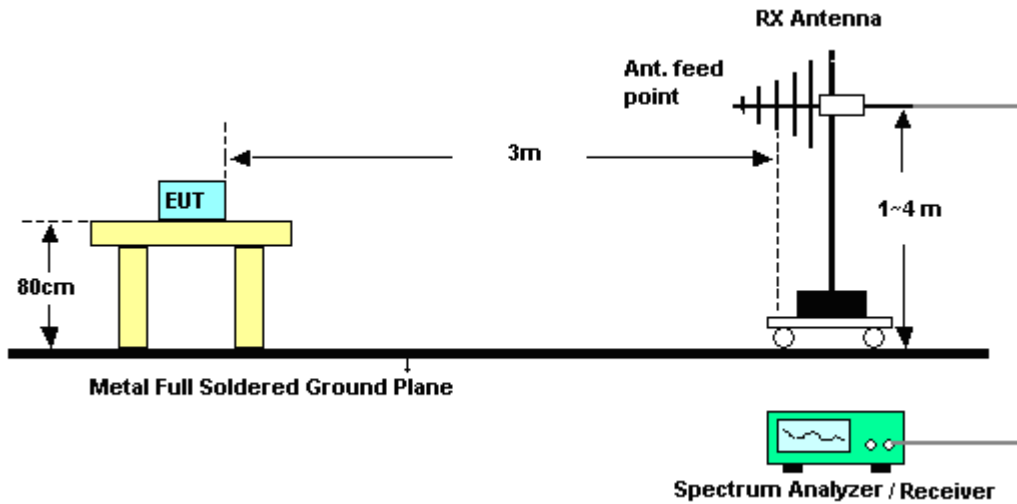

For radiated emissions above 1GHz

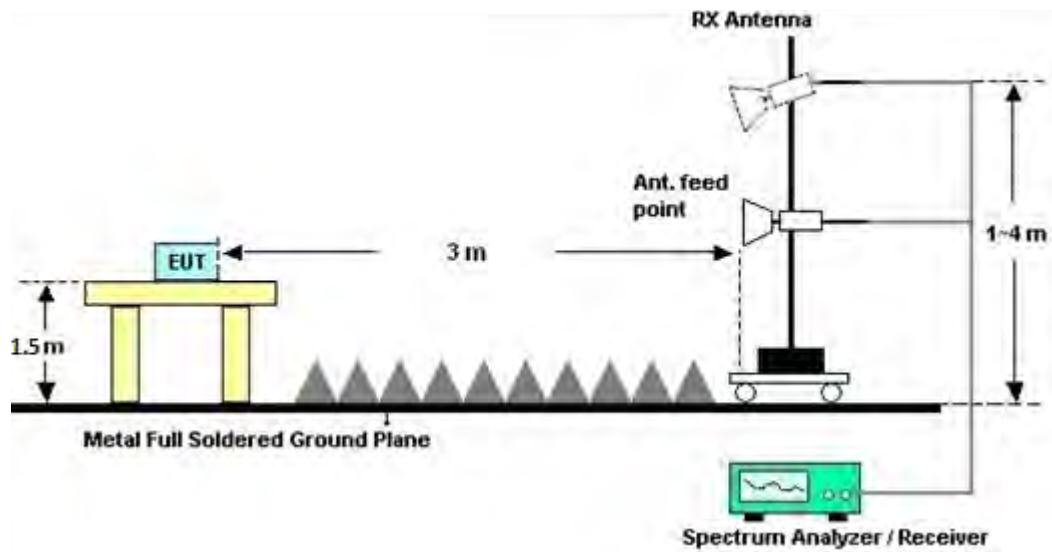

3.5.5 Test Results of Radiated Spurious Emissions (9kHz ~ 30MHz)

The low frequency, which started from 9 kHz to 30MHz, was pre-scanned and the result which was 20dB lower than the limit line per 15.31(o) was not reported.

3.5.6 Test Result of Radiated Spurious at Band Edges

Please refer to Appendix B.

3.5.7 Test Result of Radiated Spurious Emission (30MHz ~ 10th Harmonic)

Please refer to Appendix B.



3.6 AC Conducted Emission Measurement

3.6.1 Limit of AC Conducted Emission

For equipment that is designed to be connected to the public utility (AC) power line, the radio frequency voltage that is conducted back onto the AC power line on any frequency or frequencies within the band 150 kHz to 30 MHz shall not exceed the limits in the following table.

Frequency of Emission (MHz)	Conducted Limit (dB μ V)	
	Quasi-Peak	Average
0.15-0.5	66 to 56*	56 to 46*
0.5-5	56	46
5-30	60	50

*Decreases with the logarithm of the frequency.

3.6.2 Measuring Instruments

The measuring equipment is listed in the section 4 of this test report.

3.6.3 Test Procedures

1. The EUT was placed 0.4 meter from the conducting wall of the shielding room, and it was kept at least 80 centimeters from any other grounded conducting surface.
2. Connect EUT to the power mains through a line impedance stabilization network (LISN).
3. All the support units are connecting to the other LISN.
4. The LISN provides 50 ohm coupling impedance for the measuring instrument.
5. The FCC states that a 50 ohm, 50 microhenry LISN should be used.
6. Both sides of AC line were checked for maximum conducted interference.
7. The frequency range from 150 kHz to 30 MHz was searched.
8. Set the test-receiver system to Peak Detect Function and specified bandwidth (IF bandwidth = 9kHz) with Maximum Hold Mode.

3.6.4 Test Setup

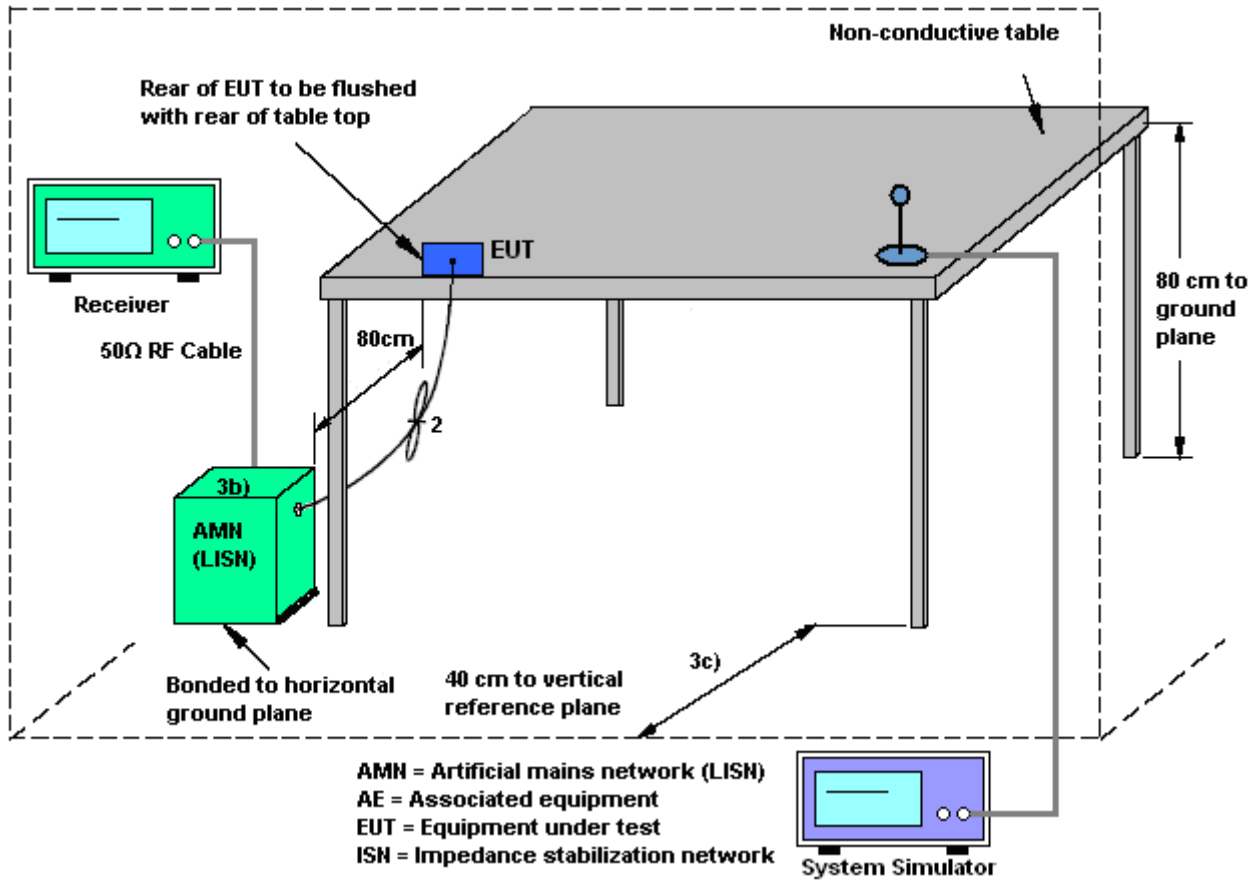



3.6.5 Test Result of AC Conducted Emission

Test Mode :	Mode 1	Temperature :	21~23°C
Test Engineer :	Jacky Yang	Relative Humidity :	41~43%
Test Voltage :	120Vac / 60Hz	Phase :	Line
Function Type :	GSM850 Idle + Bluetooth Link + WLAN Link(2.4G) + Earphone + USB Cable (Charging from Adapter)		

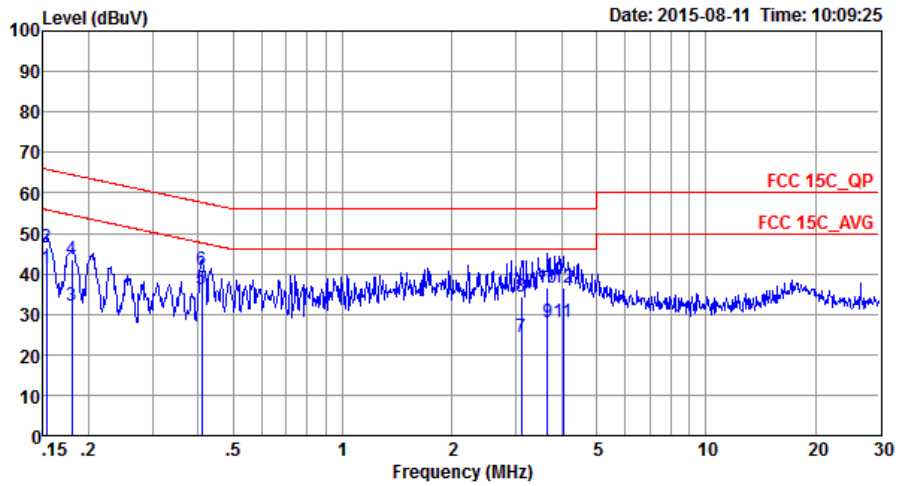

Site : C001-SZ
 Condition: FCC 15C_QP LISN_L_20150304 LINE
 Mode : Mode 1

	Freq	Level	Over Limit	Limit Line	Read Level	LISN Factor	Cable Loss	Remark
	MHz	dBuV	dB	dBuV	dBuV	dB	dB	
1	0.15	41.29	-14.53	55.82	30.49	0.44	10.36	Average
2	0.15	46.49	-19.33	65.82	35.69	0.44	10.36	QP
3	0.18	32.11	-22.39	54.50	21.30	0.49	10.32	Average
4	0.18	43.51	-20.99	64.50	32.70	0.49	10.32	QP
5 *	0.41	36.02	-11.62	47.64	25.30	0.55	10.17	Average
6	0.41	41.02	-16.62	57.64	30.30	0.55	10.17	QP
7	3.11	24.37	-21.63	46.00	13.61	0.55	10.21	Average
8	3.11	34.47	-21.53	56.00	23.71	0.55	10.21	QP
9	3.66	28.01	-17.99	46.00	17.20	0.59	10.22	Average
10	3.66	36.51	-19.49	56.00	25.70	0.59	10.22	QP
11	4.05	28.14	-17.86	46.00	17.30	0.61	10.23	Average
12	4.05	36.64	-19.36	56.00	25.80	0.61	10.23	QP



Test Mode :	Mode 1	Temperature :	21~23°C
Test Engineer :	Jacky Yang	Relative Humidity :	41~43%
Test Voltage :	120Vac / 60Hz	Phase :	Neutral
Function Type :	GSM850 Idle + Bluetooth Link + WLAN Link(2.4G) + Earphone + USB Cable (Charging from Adapter)		

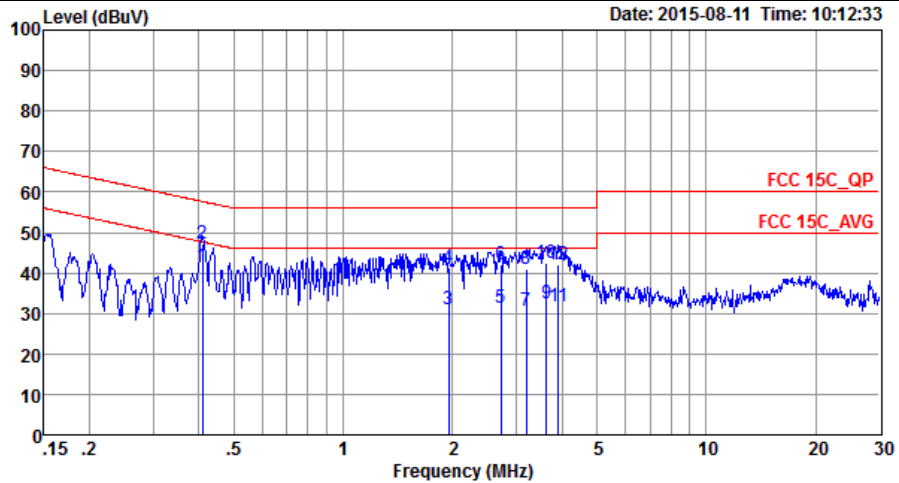

Site : CO01-SZ
 Condition: FCC 15C_QP LISN_N_20150304 NEUTRAL
 Mode : Mode 1

	Freq	Level	Over	Limit	Read	LISN	Cable	
	MHz	dBuV	Limit	Line	Level	Factor	Loss	Remark
			dB	dBuV	dBuV	dB	dB	
1 *	0.41	41.53	-6.11	47.64	30.80	0.56	10.17	Average
2	0.41	47.13	-10.51	57.64	36.40	0.56	10.17	QP
3	1.95	31.06	-14.94	46.00	20.30	0.57	10.19	Average
4	1.95	41.46	-14.54	56.00	30.70	0.57	10.19	QP
5	2.72	31.40	-14.60	46.00	20.59	0.60	10.21	Average
6	2.72	42.00	-14.00	56.00	31.19	0.60	10.21	QP
7	3.19	30.53	-15.47	46.00	19.71	0.61	10.21	Average
8	3.19	40.93	-15.07	56.00	30.11	0.61	10.21	QP
9	3.62	32.44	-13.56	46.00	21.60	0.62	10.22	Average
10	3.62	42.54	-13.46	56.00	31.70	0.62	10.22	QP
11	3.92	31.65	-14.35	46.00	20.79	0.63	10.23	Average
12	3.92	41.95	-14.05	56.00	31.09	0.63	10.23	QP



3.7 Antenna Requirements

3.7.1 Standard Applicable

If directional gain of transmitting antennas is greater than 6dBi, the power shall be reduced by the same level in dB comparing to gain minus 6dBi. For the fixed point-to-point operation, the power shall be reduced by one dB for every 3 dB that the directional gain of the antenna exceeds 6 dBi. The use of a permanently attached antenna or of an antenna that uses a unique coupling to the intentional radiator shall be considered sufficient to comply with the FCC rule.

3.7.2 Antenna Anti-Replacement Construction

An embedded-in antenna design is used.

3.7.3 Antenna Gain

The antenna peak gain of EUT is less than 6 dBi. Therefore, it is not necessary to reduce maximum peak output power limit.



4 List of Measuring Equipment

Instrument	Manufacturer	Model No.	Serial No.	Characteristics	Calibration Date	Test Date	Due Date	Remark
Spectrum Analyzer	R&S	FSV40	101078	9kHz~40GHz	May 05, 2015	Aug. 20, 2015~ Sep. 08, 2015	May 04, 2016	Conducted (TH01-SZ)
Pulse Power Sensor	Anritsu	MA2411B	1207253	30MHz~40GHz	Jan. 28, 2015	Aug. 20, 2015~ Sep. 08, 2015	Jan. 27, 2016	Conducted (TH01-SZ)
Power Meter	Anritsu	ML2495A	1218010	50MHz Bandwidth	Jan. 28, 2015	Aug. 20, 2015~ Sep. 08, 2015	Jan. 27, 2016	Conducted (TH01-SZ)
EMI Test Receiver	R&S	ESR7	101404	9kHz~7GHz; Max 30dBm	Oct. 14, 2014	Sep. 07, 2015	Oct. 13, 2015	Radiation (03CH02-SZ)
Spectrum Analyzer	R&S	FSV40	101041	10kHz~40GHz; Max 30dBm	Oct. 15, 2014	Sep. 07, 2015	Oct. 14, 2015	Radiation (03CH02-SZ)
Loop Antenna	R&S	HFH2-Z2	100354	9kHz~30MHz	May 06, 2015	Sep. 07, 2015	May 05, 2016	Radiation (03CH02-SZ)
Bilog Antenna	TeseQ	CBL6112D	23188	30MHz~2GHz	Nov. 07, 2014	Sep. 07, 2015	Nov. 06, 2015	Radiation (03CH02-SZ)
Double Ridge Horn Antenna	SCHWARZBECK	BBHA 9120D	9120D-1285	1GHz~18GHz	Jan. 20, 2015	Sep. 07, 2015	Jan. 19, 2016	Radiation (03CH02-SZ)
SHF-EHF Horn	com-power	AH-840	101071	18GHz~40GHz	Sep. 03, 2015	Sep. 06, 2015	Sep. 02, 2016	Radiation (03CH02-SZ)
Amplifier	ADVANTEST	BB525C	E9007003	9kHz~3000MHz / 30 dB	Jan. 28, 2015	Sep. 07, 2015	Jan. 27, 2016	Radiation (03CH02-SZ)
Amplifier	Agilent	8449B	3008A01023	1GHz~26.5GHz	Oct. 29, 2014	Sep. 07, 2015	Oct. 28, 2015	Radiation (03CH02-SZ)
AC Power Source	Chroma	61601	6160100024 70	N/A	NCR	Sep. 07, 2015	NCR	Radiation (03CH02-SZ)
Turn Table	Chaintek	T-200	N/A	0~360 degree	NCR	Sep. 07, 2015	NCR	Radiation (03CH02-SZ)
Antenna Mast	Chaintek	MBS-400	N/A	1 m~4 m	NCR	Sep. 07, 2015	NCR	Radiation (03CH02-SZ)
EMI Receiver	R&S	ESCI7	100724	9kHz~3GHz;	Jan. 28, 2015	Aug. 11, 2015	Jan. 27, 2016	Conduction (CO01-SZ)
AC LISN	EMCO	3816/2SH	103892	9kHz~30MHz	Feb. 02, 2015	Aug. 11, 2015	Feb. 01, 2016	Conduction (CO01-SZ)
AC LISN (for auxiliary equipment)	MessTec	AN3016	16850	9kHz~30MHz	Feb. 02, 2015	Aug. 11, 2015	Feb. 01, 2016	Conduction (CO01-SZ)
AC Power Source	Chroma	61602	6160200008 91	100Vac~250Vac	Sep. 29, 2014	Aug. 11, 2015	Sep. 28, 2015	Conduction (CO01-SZ)
Pulse Limiter	COM-POWER	LIT-153 Transient Limiter	53139	150kHz~30MHz	Oct. 24, 2014	Aug. 11, 2015	Oct. 23, 2015	Conduction (CO01-SZ)



5 Uncertainty of Evaluation

Uncertainty of Conducted Emission Measurement (150kHz ~ 30MHz)

Measuring Uncertainty for a Level of Confidence of 95% ($U = 2Uc(y)$)	2.3dB
---	-------

Uncertainty of Radiated Emission Measurement (30 MHz ~ 1000 MHz)

Measuring Uncertainty for a Level of Confidence of 95% ($U = 2Uc(y)$)	4.5dB
---	-------



Appendix A. Conducted Test Results

A1 - DTS Part

Test Engineer:	Sam Zheng	Temperature:	24~26	°C
Test Date:	2015/8/20 ~ 2015/9/8	Relative Humidity:	50~53	%

TEST RESULTS DATA
6dB and 99% Occupied Bandwidth

2.4GHz Band								
Mod.	Data Rate	NTX	CH.	Freq. (MHz)	99% Occupied BW (MHz)	6dB BW (MHz)	6dB BW Limit (MHz)	Pass/Fail
11b	1Mbps	1	1	2412	13.19	9.57	0.50	Pass
11b	1Mbps	1	6	2437	13.44	9.55	0.50	Pass
11b	1Mbps	1	11	2462	11.14	6.55	0.50	Pass
11g	6Mbps	1	1	2412	17.83	15.74	0.50	Pass
11g	6Mbps	1	6	2437	18.03	15.74	0.50	Pass
11g	6Mbps	1	11	2462	15.93	7.59	0.50	Pass
HT20	MCS0	1	1	2412	18.33	16.34	0.50	Pass
HT20	MCS0	1	6	2437	18.68	16.34	0.50	Pass
HT20	MCS0	1	11	2462	16.78	7.55	0.50	Pass
HT40	MCS0	1	3	2422	36.66	13.79	0.50	Pass
HT40	MCS0	1	6	2437	36.56	35.09	0.50	Pass
HT40	MCS0	1	9	2452	35.66	10.07	0.50	Pass

TEST RESULTS DATA
Peak Power Table

2.4GHz Band										
Mod.	Data Rate	NTX	CH.	Freq. (MHz)	Peak Conducted Power (dBm)	Conducted Power Limit (dBm)	DG (dBi)	EIRP Power (dBm)	EIRP Power Limit (dBm)	Pass /Fail
11b	1Mbps	1	1	2412	16.88	30.00	-1.00	15.88	36.00	Pass
11b	1Mbps	1	6	2437	16.09	30.00	-1.00	15.09	36.00	Pass
11b	1Mbps	1	11	2462	15.36	30.00	-1.00	14.36	36.00	Pass
11g	6Mbps	1	1	2412	18.78	30.00	-1.00	17.78	36.00	Pass
11g	6Mbps	1	6	2437	18.90	30.00	-1.00	17.90	36.00	Pass
11g	6Mbps	1	11	2462	17.97	30.00	-1.00	16.97	36.00	Pass
HT20	MCS0	1	1	2412	19.16	30.00	-1.00	18.16	36.00	Pass
HT20	MCS0	1	6	2437	19.23	30.00	-1.00	18.23	36.00	Pass
HT20	MCS0	1	11	2462	17.49	30.00	-1.00	16.49	36.00	Pass
HT40	MCS0	1	3	2422	18.79	30.00	-1.00	17.79	36.00	Pass
HT40	MCS0	1	6	2437	20.65	30.00	-1.00	19.65	36.00	Pass
HT40	MCS0	1	9	2452	17.42	30.00	-1.00	16.42	36.00	Pass

TEST RESULTS DATA
Average Power Table
(Reporting Only)

2.4GHz Band						
Mod.	Data Rate	N _{TX}	CH.	Freq. (MHz)	Duty Factor (dB)	Average Conducted Power (dBm)
11b	1Mbps	1	1	2412	0.09	14.30
11b	1Mbps	1	6	2437	0.09	13.70
11b	1Mbps	1	11	2462	0.09	12.43
11g	6Mbps	1	1	2412	0.51	9.92
11g	6Mbps	1	6	2437	0.51	10.22
11g	6Mbps	1	11	2462	0.51	8.32
HT20	MCS0	1	1	2412	0.54	10.28
HT20	MCS0	1	6	2437	0.54	10.41
HT20	MCS0	1	11	2462	0.54	8.15
HT40	MCS0	1	3	2422	1.02	9.13
HT40	MCS0	1	6	2437	1.02	10.28
HT40	MCS0	1	9	2452	1.02	6.89

TEST RESULTS DATA
Peak Power Density

2.4GHz Band								
Mod.	Data Rate	NTX	CH.	Freq. (MHz)	Peak PSD (dBm /3kHz)	DG (dBi)	Peak PSD Limit (dBm /3kHz)	Pass/Fail
11b	1Mbps	1	1	2412	-7.69	-1.00	8.00	Pass
11b	1Mbps	1	6	2437	-9.32	-1.00	8.00	Pass
11b	1Mbps	1	11	2462	-8.67	-1.00	8.00	Pass
11g	6Mbps	1	1	2412	-12.88	-1.00	8.00	Pass
11g	6Mbps	1	6	2437	-12.69	-1.00	8.00	Pass
11g	6Mbps	1	11	2462	-12.71	-1.00	8.00	Pass
HT20	MCS0	1	1	2412	-11.54	-1.00	8.00	Pass
HT20	MCS0	1	6	2437	-12.47	-1.00	8.00	Pass
HT20	MCS0	1	11	2462	-10.17	-1.00	8.00	Pass
HT40	MCS0	1	3	2422	-14.86	-1.00	8.00	Pass
HT40	MCS0	1	6	2437	-14.33	-1.00	8.00	Pass
HT40	MCS0	1	9	2452	-17.73	-1.00	8.00	Pass



Appendix B. Radiated Spurious Emission

15C 2.4GHz 2400~2483.5MHz

WIFI 802.11b (Band Edge @ 3m)

WIFI	Note	Frequency	Level	Over	Limit	Read	Antenna	Cable	Preamp	Ant	Table	Peak	Pol.
Ant.				Limit	Line	Level	Factor	Loss	Factor	Pos	Pos	Avg.	
1		(MHz)	(dBμV/m)	(dB)	(dBμV/m)	(dBμV)	(dB/m)	(dB)	(dB)	(cm)	(deg)	(P/A)	(H/V)
802.11b CH 01 2412MHz		2381.82	43.04	-30.96	74	43.74	27.19	9.32	37.21	170	312	P	H
		2389.56	29.07	-24.93	54	29.73	27.25	9.32	37.23	170	312	A	H
	*	2412	84.95	-	-	85.45	27.31	9.43	37.24	170	312	P	H
	*	2412	80.12	-	-	80.62	27.31	9.43	37.24	170	312	A	H
		2346.36	42.7	-31.3	74	43.61	27.07	9.2	37.18	150	95	P	V
		2389.65	28.88	-25.12	54	29.54	27.25	9.32	37.23	150	95	A	V
	*	2412	82.34	-	-	82.84	27.31	9.43	37.24	150	95	P	V
	*	2412	77.48	-	-	77.98	27.31	9.43	37.24	150	95	A	V
802.11b CH 06 2437MHz		2381.19	42.46	-31.54	74	43.16	27.19	9.32	37.21	166	310	P	H
		2369.85	29.06	-24.94	54	29.76	27.19	9.32	37.21	166	310	A	H
	*	2437	85.16	-	-	85.58	27.42	9.43	37.27	166	310	P	H
	*	2437	80.21	-	-	80.63	27.42	9.43	37.27	166	310	A	H
		2483.6	43.2	-30.8	74	43.41	27.54	9.55	37.3	166	310	P	H
		2498.48	29.8	-24.2	54	29.86	27.6	9.66	37.32	166	310	A	H
		2389.47	42.78	-31.22	74	43.44	27.25	9.32	37.23	151	118	P	V
		2386.77	28.94	-25.06	54	29.6	27.25	9.32	37.23	151	118	A	V
	*	2437	83.83	-	-	84.25	27.42	9.43	37.27	151	118	P	V
	*	2437	78.99	-	-	79.41	27.42	9.43	37.27	151	118	A	V
		2483.6	43.94	-30.06	74	44.15	27.54	9.55	37.3	151	118	P	V
	2497.72	29.61	-24.39	54	29.67	27.6	9.66	37.32	151	118	A	V	



802.11b CH 11 2462MHz	*	2462	82.53	-	-	82.79	27.48	9.55	37.29	156	175	P	H
	*	2462	76.75	-	-	77.01	27.48	9.55	37.29	156	175	A	H
		2490.04	43.61	-30.39	74	43.67	27.6	9.66	37.32	156	175	P	H
		2498.48	29.55	-24.45	54	29.61	27.6	9.66	37.32	156	175	A	H
	*	2462	78.99	-	-	79.25	27.48	9.55	37.29	163	89	P	V
	*	2462	73.21	-	-	73.47	27.48	9.55	37.29	163	89	A	V
		2489.2	42.9	-31.1	74	42.96	27.6	9.66	37.32	163	89	P	V
		2499.32	29.48	-24.52	54	29.54	27.6	9.66	37.32	163	89	A	V
Remark	1. No other spurious found. 2. All results are PASS against Peak and Average limit line.												



15C 2.4GHz 2400~2483.5MHz

WIFI 802.11b (Harmonic @ 3m)

WIFI	Note	Frequency	Level	Over	Limit	Read	Antenna	Cable	Preamp	Ant	Table	Peak	Pol.
Ant.				Limit	Line	Level	Factor	Loss	Factor	Pos	Pos	Avg.	
1		(MHz)	(dBμV/m)	(dB)	(dBμV/m)	(dBμV)	(dB/m)	(dB)	(dB)	(cm)	(deg)	(P/A)	(H/V)
802.11b CH 01 2412MHz		4824	43.27	-30.73	74	35.12	31.26	13.37	36.48	150	360	P	H
		4824	42.17	-31.83	74	34.02	31.26	13.37	36.48	150	360	P	V
802.11b CH 06 2437MHz		4874	44.07	-29.93	74	35.68	31.36	13.48	36.45	150	360	P	H
		7311	50.23	-23.77	74	35.3	35.96	16.59	37.62	174	100	P	H
		4874	43.54	-30.46	74	35.15	31.36	13.48	36.45	150	360	P	V
		7311	45.57	-28.43	74	30.64	35.96	16.59	37.62	174	100	P	V
802.11b CH 11 2462MHz		4924	39.62	-34.38	74	30.99	31.46	13.59	36.42	150	360	P	H
		7386	44.78	-29.22	74	29.67	36.08	16.66	37.63	150	274	P	H
		4924	39.15	-34.85	74	30.52	31.46	13.59	36.42	150	360	P	V
		7386	44.81	-29.19	74	29.7	36.08	16.66	37.63	150	274	P	V
Remark	1. No other spurious found. 2. All results are PASS against Peak and Average limit line.												



**15C 2.4GHz 2400~2483.5MHz
WIFI 802.11g (Band Edge @ 3m)**

WIFI	Note	Frequency	Level	Over	Limit	Read	Antenna	Cable	Preamp	Ant	Table	Peak	Pol.
Ant.				Limit	Line	Level	Factor	Loss	Factor	Pos	Pos	Avg.	
1		(MHz)	(dBμV/m)	(dB)	(dBμV/m)	(dBμV)	(dB/m)	(dB)	(dB)	(cm)	(deg)	(P/A)	(H/V)
802.11g CH 01 2412MHz		2366.88	42.83	-31.17	74	43.69	27.13	9.2	37.19	150	132	P	H
		2389.83	29.59	-24.41	54	30.25	27.25	9.32	37.23	150	132	A	H
	*	2412	81	-	-	81.5	27.31	9.43	37.24	150	132	P	H
	*	2412	70.76	-	-	71.26	27.31	9.43	37.24	150	132	A	H
		2348.61	42.14	-31.86	74	43.05	27.07	9.2	37.18	166	112	P	V
		2389.83	29.27	-24.73	54	29.93	27.25	9.32	37.23	166	112	A	V
	*	2412	80.38	-	-	80.88	27.31	9.43	37.24	166	112	P	V
	*	2412	69.72	-	-	70.22	27.31	9.43	37.24	166	112	A	V
802.11g CH 06 2437MHz		2348.43	42.71	-31.29	74	43.62	27.07	9.2	37.18	154	91	P	H
		2363.19	28.99	-25.01	54	29.85	27.13	9.2	37.19	154	91	A	H
	*	2437	87.2	-	-	87.62	27.42	9.43	37.27	154	91	P	H
	*	2437	75.31	-	-	75.73	27.42	9.43	37.27	154	91	A	H
		2484.36	43.42	-30.58	74	43.63	27.54	9.55	37.3	154	91	P	H
		2484.2	30.02	-23.98	54	30.23	27.54	9.55	37.3	154	91	A	H
		2340.96	43.39	-30.61	74	44.3	27.07	9.2	37.18	177	36	P	V
		2384.16	29.07	-24.93	54	29.77	27.19	9.32	37.21	177	36	A	V
	*	2437	82.47	-	-	82.89	27.42	9.43	37.27	177	36	P	V
	*	2437	69.5	-	-	69.92	27.42	9.43	37.27	177	36	A	V
		2499.12	43.16	-30.84	74	43.22	27.6	9.66	37.32	177	36	P	V
		2498.52	29.75	-24.25	54	29.81	27.6	9.66	37.32	177	36	A	V



802.11g CH 11 2462MHz	*	2462	84.01	-	-	84.27	27.48	9.55	37.29	166	324	P	H
	*	2462	73.54	-	-	73.8	27.48	9.55	37.29	166	324	A	H
		2484	44.85	-29.15	74	45.06	27.54	9.55	37.3	166	324	P	H
		2498.4	30.23	-23.77	54	30.29	27.6	9.66	37.32	166	324	A	H
	*	2462	78.29	-	-	78.55	27.48	9.55	37.29	184	60	P	V
	*	2462	67.74	-	-	68	27.48	9.55	37.29	184	60	A	V
		2485.76	43.63	-30.37	74	43.84	27.54	9.55	37.3	184	60	P	V
		2500	30.16	-23.84	54	30.22	27.6	9.66	37.32	184	60	A	V
Remark	1. No other spurious found. 2. All results are PASS against Peak and Average limit line.												



15C 2.4GHz 2400~2483.5MHz

WIFI 802.11g (Harmonic @ 3m)

WIFI	Note	Frequency	Level	Over	Limit	Read	Antenna	Cable	Preamp	Ant	Table	Peak	Pol.
Ant.				Limit	Line	Level	Factor	Loss	Factor	Pos	Pos	Avg.	
1		(MHz)	(dBμV/m)	(dB)	(dBμV/m)	(dBμV)	(dB/m)	(dB)	(dB)	(cm)	(deg)	(P/A)	(H/V)
802.11g		4824	38.21	-35.79	74	30.06	31.26	13.37	36.48	150	360	P	H
CH 01		4824	39.99	-34.01	74	31.84	31.26	13.37	36.48	150	360	P	V
2412MHz													
802.11g		4874	38.77	-35.23	74	30.38	31.36	13.48	36.45	150	360	P	H
CH 06		7311	45.41	-28.59	74	30.48	35.96	16.59	37.62	174	100	P	H
2437MHz		4874	39.03	-34.97	74	30.64	31.36	13.48	36.45	150	360	P	V
		7311	44.28	-29.72	74	29.35	35.96	16.59	37.62	174	100	P	V
802.11g		4924	38.33	-35.67	74	29.7	31.46	13.59	36.42	150	360	P	H
CH 11		7386	43.8	-30.2	74	28.69	36.08	16.66	37.63	150	274	P	H
2462MHz		4924	38.25	-35.75	74	29.62	31.46	13.59	36.42	150	360	P	V
		7386	44.06	-29.94	74	28.95	36.08	16.66	37.63	150	274	P	V
Remark	<ol style="list-style-type: none"> No other spurious found. All results are PASS against Peak and Average limit line. 												



**15C 2.4GHz 2400~2483.5MHz
WIFI 802.11n HT20 (Band Edge @ 3m)**

WIFI	Note	Frequency	Level	Over	Limit	Read	Antenna	Cable	Preamp	Ant	Table	Peak	Pol.
Ant.				Limit	Line	Level	Factor	Loss	Factor	Pos	Pos	Avg.	
1		(MHz)	(dBμV/m)	(dB)	(dBμV/m)	(dBμV)	(dB/m)	(dB)	(dB)	(cm)	(deg)	(P/A)	(H/V)
802.11n HT20 CH 01 2412MHz		2389.2	43.78	-30.22	74	44.44	27.25	9.32	37.23	150	131	P	H
		2389.92	30.36	-23.64	54	31.02	27.25	9.32	37.23	150	131	A	H
	*	2412	83.63	-	-	84.13	27.31	9.43	37.24	150	131	P	H
	*	2412	73.4	-	-	73.9	27.31	9.43	37.24	150	131	A	H
		2386.41	42.83	-31.17	74	43.49	27.25	9.32	37.23	161	108	P	V
		2389.92	29.5	-24.5	54	30.16	27.25	9.32	37.23	161	108	A	V
	*	2412	79.54	-	-	80.04	27.31	9.43	37.24	161	108	P	V
	*	2412	68.91	-	-	69.41	27.31	9.43	37.24	161	108	A	V
802.11n HT20 CH 06 2437MHz		2381.91	42.56	-31.44	74	43.26	27.19	9.32	37.21	170	136	P	H
		2370.48	29.15	-24.85	54	29.85	27.19	9.32	37.21	170	136	A	H
	*	2437	86.79	-	-	87.21	27.42	9.43	37.27	170	136	P	H
	*	2437	74.59	-	-	75.01	27.42	9.43	37.27	170	136	A	H
		2484.32	42.92	-31.08	74	43.13	27.54	9.55	37.3	170	136	P	H
		2483.88	29.89	-24.11	54	30.1	27.54	9.55	37.3	170	136	A	H
		2354.64	42.52	-31.48	74	43.38	27.13	9.2	37.19	168	121	P	V
		2383.44	29.07	-24.93	54	29.77	27.19	9.32	37.21	168	121	A	V
	*	2437	83.05	-	-	83.47	27.42	9.43	37.27	168	121	P	V
	*	2437	70.96	-	-	71.38	27.42	9.43	37.27	168	121	A	V
		2490.8	43.01	-30.99	74	43.07	27.6	9.66	37.32	168	121	P	V
	2496.28	29.91	-24.09	54	29.97	27.6	9.66	37.32	168	121	A	V	



802.11n HT20 CH 11 2462MHz	*	2462	82.22	-	-	82.48	27.48	9.55	37.29	150	120	P	H
	*	2462	71.14	-	-	71.4	27.48	9.55	37.29	150	120	A	H
		2497.68	43.61	-30.39	74	43.67	27.6	9.66	37.32	150	120	P	H
		2498.8	30.04	-23.96	54	30.1	27.6	9.66	37.32	150	120	A	H
	*	2462.124	81.7	-	-	81.96	27.48	9.55	37.29	164	112	P	V
	*	2462.291	71.16	-	-	71.42	27.48	9.55	37.29	164	112	A	V
		2492.32	43.51	-30.49	74	43.57	27.6	9.66	37.32	164	112	P	V
		2497.52	30.16	-23.84	54	30.22	27.6	9.66	37.32	164	112	A	V
Remark	1. No other spurious found. 2. All results are PASS against Peak and Average limit line.												



15C 2.4GHz 2400~2483.5MHz
WIFI 802.11n HT20 (Harmonic @ 3m)

Table with 14 columns: WIFI Ant., Note, Frequency (MHz), Level (dBµV/m), Over Limit (dB), Limit Line (dBµV/m), Read Level (dBµV), Antenna Factor (dB/m), Cable Loss (dB), Preamp Factor (dB), Ant Pos (cm), Table Pos (deg), Peak Avg. (P/A), Pol. (H/V). Rows include data for 802.11n HT20 CH 01 (2412MHz) and CH 06 (2437MHz), and 802.11n HT20 CH 11 (2462MHz).

Remark

- 1. No other spurious found.
2. All results are PASS against Peak and Average limit line.



**15C 2.4GHz 2400~2483.5MHz
WIFI 802.11n HT40 (Band Edge @ 3m)**

WIFI	Note	Frequency	Level	Over	Limit	Read	Antenna	Cable	Preamp	Ant	Table	Peak	Pol.
Ant.				Limit	Line	Level	Factor	Loss	Factor	Pos	Pos	Avg.	
1		(MHz)	(dBμV/m)	(dB)	(dBμV/m)	(dBμV)	(dB/m)	(dB)	(dB)	(cm)	(deg)	(P/A)	(H/V)
802.11n HT40 CH 03 2422MHz		2363.19	42.21	-31.79	74	43.07	27.13	9.2	37.19	222	130	P	H
		2387.85	29.84	-24.16	54	30.5	27.25	9.32	37.23	222	130	A	H
	*	2422	83.02	-	-	83.48	27.37	9.43	37.26	222	130	P	H
	*	2422	72.21	-	-	72.67	27.37	9.43	37.26	222	130	A	H
		2499.52	43.11	-30.89	74	43.17	27.6	9.66	37.32	222	130	P	H
		2498.8	30.52	-23.48	54	30.58	27.6	9.66	37.32	222	130	P	H
		2340.69	42.56	-31.44	74	43.47	27.07	9.2	37.18	233	165	P	V
		2387.85	29.42	-24.58	54	30.08	27.25	9.32	37.23	233	165	P	V
	*	2422	80.3	-	-	80.76	27.37	9.43	37.26	233	165	P	V
	*	2422	69.05	-	-	69.51	27.37	9.43	37.26	233	165	A	V
		2495.12	43.4	-30.6	74	43.46	27.6	9.66	37.32	233	165	P	V
		2498.04	30.63	-23.37	54	30.69	27.6	9.66	37.32	233	165	A	V
802.11n HT40 CH 06 2437MHz		2373.45	42.41	-31.59	74	43.11	27.19	9.32	37.21	150	124	P	H
		2382.45	29.84	-24.16	54	30.54	27.19	9.32	37.21	150	124	A	H
	*	2437	85.42	-	-	85.84	27.42	9.43	37.27	150	124	P	H
	*	2437	74.89	-	-	75.31	27.42	9.43	37.27	150	124	A	H
		2496.36	43.13	-30.87	74	43.19	27.6	9.66	37.32	150	124	P	H
		2483.68	30.73	-23.27	54	30.94	27.54	9.55	37.3	150	124	A	H
		2386.05	42.66	-31.34	74	43.32	27.25	9.32	37.23	216	118	P	V
		2384.7	30.22	-23.78	54	30.92	27.19	9.32	37.21	216	118	A	V
	*	2437	83.48	-	-	83.9	27.42	9.43	37.27	216	118	P	V
	*	2437	72.25	-	-	72.67	27.42	9.43	37.27	216	118	A	V
		2493.32	43.48	-30.52	74	43.54	27.6	9.66	37.32	216	118	P	V
		2496.96	30.53	-23.47	54	30.59	27.6	9.66	37.32	216	118	A	V



802.11n HT40 CH 09 2452MHz		2358.69	42.57	-31.43	74	43.43	27.13	9.2	37.19	240	316	P	H
		2384.79	29.92	-24.08	54	30.62	27.19	9.32	37.21	240	316	A	H
	*	2452	80.66	-	-	80.96	27.42	9.55	37.27	240	316	P	H
	*	2452	69.87	-	-	70.17	27.42	9.55	37.27	240	316	A	H
		2483.76	44.96	-29.04	74	45.17	27.54	9.55	37.3	240	316	P	H
		2497.44	30.92	-23.08	54	30.98	27.6	9.66	37.32	240	316	A	H
		2358.15	43.41	-30.59	74	44.27	27.13	9.2	37.19	186	152	P	V
		2387.13	29.89	-24.11	54	30.55	27.25	9.32	37.23	186	152	A	V
	*	2452	75.69	-	-	75.99	27.42	9.55	37.27	186	152	P	V
	*	2452	64.89	-	-	65.19	27.42	9.55	37.27	186	152	A	V
		2488.44	43.95	-30.05	74	44.01	27.6	9.66	37.32	186	152	P	V
		2483.52	30.72	-23.28	54	30.93	27.54	9.55	37.3	186	152	A	V
Remark	1. No other spurious found. 2. All results are PASS against Peak and Average limit line.												



**15C 2.4GHz 2400~2483.5MHz
WIFI 802.11n HT40 (Harmonic @ 3m)**

WIFI	Note	Frequency	Level	Over	Limit	Read	Antenna	Cable	Preamp	Ant	Table	Peak	Pol.
Ant.				Limit	Line	Level	Factor	Loss	Factor	Pos	Pos	Avg.	
1		(MHz)	(dBμV/m)	(dB)	(dBμV/m)	(dBμV)	(dB/m)	(dB)	(dB)	(cm)	(deg)	(P/A)	(H/V)
802.11n		4844	37.68	-36.32	74	29.49	31.29	13.37	36.47	150	360	P	H
HT40		7266	43.89	-30.11	74	29.05	35.91	16.55	37.62	200	360	P	H
CH 03		4844	38.66	-35.34	74	30.47	31.29	13.37	36.47	150	360	P	V
2422MHz		7266	44.54	-29.46	74	29.7	35.91	16.55	37.62	200	360	P	V
802.11n		4874	39.8	-34.2	74	31.41	31.36	13.48	36.45	150	360	P	H
HT40		7311	45.73	-28.27	74	30.8	35.96	16.59	37.62	150	360	P	H
CH 06		4874	38.04	-35.96	74	29.65	31.36	13.48	36.45	150	360	P	V
2437MHz		7311	44.53	-29.47	74	29.6	35.96	16.59	37.62	150	360	P	V
802.11n		4904	36.49	-37.51	74	27.9	31.43	13.59	36.43	150	360	P	H
HT40		7356	42.19	-31.81	74	27.17	36.03	16.62	37.63	150	360	P	H
CH 09		4904	38.37	-35.63	74	29.78	31.43	13.59	36.43	150	360	P	V
2452MHz		7356	44.1	-29.9	74	29.08	36.03	16.62	37.63	150	360	P	V
Remark	1. No other spurious found. 2. All results are PASS against Peak and Average limit line.												



**15C Emission below 1GHz
2.4GHz WIFI 802.11n HT40 (LF)**

WIFI	Note	Frequency	Level	Over	Limit	Read	Antenna	Cable	Preamp	Ant	Table	Peak	Pol.
Ant.				Limit	Line	Level	Factor	Loss	Factor	Pos	Pos	Avg.	
1		(MHz)	(dB μ V/m)	(dB)	(dB μ V/m)	(dB μ V)	(dB/m)	(dB)	(dB)	(cm)	(deg)	(P/A)	(H/V)
2.4GHz 802.11n HT40 LF		67.83	29.59	-10.41	40	51.76	6.7	1.68	30.55	135	264	P	H
		176.47	29.82	-13.68	43.5	46.27	11.41	2.58	30.44	-	-	P	H
		269.59	25.94	-20.06	46	39.79	13.41	3.06	30.32	-	-	P	H
		390.84	20.12	-25.88	46	30.82	15.76	3.67	30.13	-	-	P	H
		514.03	22.7	-23.3	46	30.34	18.07	4.21	29.92	-	-	P	H
		660.5	25.49	-20.51	46	30.67	19.64	4.88	29.7	-	-	P	H
		53.28	30.61	-9.39	40	51.65	7.84	1.68	30.56	157	262	P	V
		123.12	23.16	-20.34	43.5	38.84	12.81	2.01	30.5	-	-	P	V
		189.08	17.24	-26.26	43.5	34.42	10.67	2.58	30.43	-	-	P	V
		384.05	19.14	-26.86	46	29.97	15.64	3.67	30.14	-	-	P	V
		531.49	21.85	-24.15	46	28.99	18.33	4.42	29.89	-	-	P	V
	714.82	24.71	-21.29	46	29.42	19.9	5.01	29.62	-	-	P	V	
Remark	1. No other spurious found. 2. All results are PASS against limit line.												

Note symbol

*	Fundamental Frequency which can be ignored. However, the level of any unwanted emissions shall not exceed the level of the fundamental frequency per 15.209(c).
!	Test result is over limit line.
P/A	Peak or Average
H/V	Horizontal or Vertical



A calculation example for radiated spurious emission is shown as below:

WIFI	Note	Frequency	Level	Over	Limit	Read	Antenna	Cable	Preamp	Ant	Table	Peak	Pol.
Ant.				Limit	Line	Level	Factor	Loss	Factor	Pos	Pos	Avg.	
1+2		(MHz)	(dBμV/m)	(dB)	(dBμV/m)	(dBμV)	(dB/m)	(dB)	(dB)	(cm)	(deg)	(P/A)	(H/V)
802.11b		2390	55.45	-18.55	74	54.51	32.22	4.58	35.86	103	308	P	H
CH 01		2390	43.54	-10.46	54	42.6	32.22	4.58	35.86	103	308	A	H
2412MHz													

- Level(dBμV/m) =
Antenna Factor(dB/m) + Cable Loss(dB) + Read Level(dBμV) - Preamp Factor(dB)
- Over Limit(dB) = Level(dBμV/m) – Limit Line(dBμV/m)

For Peak Limit @ 2390MHz:

- Level(dBμV/m)
= Antenna Factor(dB/m) + Cable Loss(dB) + Read Level(dBμV) - Preamp Factor(dB)
= 32.22(dB/m) + 4.58(dB) + 54.51(dBμV) – 35.86 (dB)
= 55.45 (dBμV/m)
- Over Limit(dB)
= Level(dBμV/m) – Limit Line(dBμV/m)
= 55.45(dBμV/m) – 74(dBμV/m)
= -18.55(dB)

For Average Limit @ 2390MHz:

- Level(dBμV/m)
= Antenna Factor(dB/m) + Cable Loss(dB) + Read Level(dBμV) - Preamp Factor(dB)
= 32.22(dB/m) + 4.58(dB) + 42.6(dBμV) – 35.86 (dB)
= 43.54 (dBμV/m)
- Over Limit(dB)
= Level(dBμV/m) – Limit Line(dBμV/m)
= 43.54(dBμV/m) – 54(dBμV/m)
= -10.46(dB)

Both peak and average measured complies with the limit line, so test result is “PASS”.