



FCC RF Test Report

APPLICANT : Brightstar Corporation
EQUIPMENT : Mobile Phone
BRAND NAME : Avvio
MODEL NAME : Avvio L800S, Avvio L800
FCC ID : WVBAL800X
STANDARD : FCC 47 CFR Part 2, 22(H), 24(E)
CLASSIFICATION : PCS Licensed Transmitter Held to Ear (PCE)

The product was received on Aug. 05, 2015 and testing was completed on Aug. 29, 2015. We, SPORTON INTERNATIONAL (SHENZHEN) INC., would like to declare that the tested sample has been evaluated in accordance with the test procedures given in ANSI / TIA / EIA-603-C-2004 and has been in compliance with the applicable technical standards.

The test results in this report apply exclusively to the tested model / sample. Without written approval of SPORTON INTERNATIONAL (SHENZHEN) INC., the test report shall not be reproduced except in full.

Reviewed by: Joseph Lin / Supervisor

Approved by: Jones Tsai / Manager



Testing Laboratory

2353

SPORTON INTERNATIONAL (SHENZHEN) INC.

**1F & 2F, Building A, Morning Business Center, No. 4003 ShiGu Rd., Xili Town,
Nanshan District, Shenzhen, Guangdong, P. R. China**



TABLE OF CONTENTS

REVISION HISTORY..... 3

SUMMARY OF TEST RESULT 4

1 GENERAL DESCRIPTION 6

 1.1 Applicant..... 6

 1.2 Manufacturer 6

 1.3 Product Feature of Equipment Under Test 6

 1.4 Product Specification subjective to this standard..... 7

 1.5 Modification of EUT 7

 1.6 Maximum ERP/EIRP Power, Frequency Tolerance, and Emission Designator 8

 1.7 Testing Location 8

 1.8 Applicable Standards 9

2 TEST CONFIGURATION OF EQUIPMENT UNDER TEST 10

 2.1 Test Mode..... 10

 2.2 Connection Diagram of Test System 11

 2.3 Support Unit used in test configuration 11

 2.4 Measurement Results Explanation Example 11

3 CONDUCTED TEST RESULT..... 12

 3.1 Measuring Instruments..... 12

 3.2 Test Setup 12

 3.3 Test Result of Conducted Test..... 12

 3.4 Conducted Output Power 13

 3.5 Peak-to-Average Ratio 14

 3.6 99% Occupied Bandwidth and 26dB Bandwidth Measurement..... 15

 3.7 Conducted Band Edge 16

 3.8 Conducted Spurious Emission 17

 3.9 Frequency Stability 18

4 RADIATED TEST ITEMS 19

 4.1 Measuring Instruments..... 19

 4.2 Test Setup 19

 4.3 Test Result of Radiated Test..... 19

 4.4 Effective Radiated Power and Effective Isotropic Radiated Power Measurement 20

 4.5 Field Strength of Spurious Radiation Measurement 22

5 LIST OF MEASURING EQUIPMENT 23

6 UNCERTAINTY OF EVALUATION 24

APPENDIX A. TEST RESULTS OF CONDUCTED TEST

APPENDIX B. TEST RESULTS OF RADIATED TEST

APPENDIX C. TEST SETUP PHOTOGRAPHS



REVISION HISTORY

REPORT NO.	VERSION	DESCRIPTION	ISSUED DATE
FG580514A	Rev. 01	Initial issue of report	Sep. 15, 2015



SUMMARY OF TEST RESULT

Report Section	FCC Rule	Description	Limit	Result	Remark
3.4	§2.1046	Conducted Output Power	Reporting Only	PASS	-
3.5	§24.232(d)	Peak-to-Average Ratio	< 13 dB	PASS	-
3.6	§2.1049 §22.917(b) §24.238(b)	Occupied Bandwidth	Reporting Only	PASS	-
3.7	§2.1051 §22.917(a) §24.238(a)	Band Edge Measurement	< 43+10log10(P[Watts])	PASS	-
3.8	§2.1051 §22.917(a) §24.238(a)	Conducted Emission	< 43+10log10(P[Watts])	PASS	-
3.9	§2.1055 §22.355	Frequency Stability for Temperature & Voltage	< 2.5 ppm for Part 22	PASS	-
	§2.1055 §24.235		Within Authorized Band		



Report Section	FCC Rule	Description	Limit	Result	Remark
4.4	§22.913(a)(2)	Effective Radiated Power	< 7 Watts	PASS	-
	§24.232(c)	Equivalent Isotropic Radiated Power	< 2 Watts	PASS	-
4.5	§2.1053 §22.917(a) §24.238(a)	Field Strength of Spurious Radiation	< 43+10log10(P[Watts])	PASS	Under limit 25.91 dB at 1672.000 MHz



1 General Description

1.1 Applicant

Brightstar Corporation

9725 NW 117th Ave., Miami, Florida, FL 33178, United States

1.2 Manufacturer

Heng Da Chuang Xin Technology Limited

Rm14H Taibang Building, 4 Rd. High Tech South, Nanshan, SZ, P. R. C. 518000

1.3 Product Feature of Equipment Under Test

Product Feature	
Equipment	Mobile Phone
Brand Name	Avvio
Model Name	Avvio L800S,Avvio L800
FCC ID	WVBAL800X
EUT supports Radios application	GSM/GPRS/EGPRS/WCDMA/HSPA/HSPA+/DC-HSDPA/LTE WLAN2.4GHz 802.11b/g/n HT20/HT40 Bluetooth v3.0+EDR Bluetooth v4.0 LE
IMEI Code	Conducted: 358151060000311 Radiation:358151060000345 ERP/EIRP: 358151060000345
HW Version	M326B
SW Version	AVVIO_L800_V1_0_1
EUT Stage	Production Unit

Remark:

1. The above EUT's information was declared by manufacturer. Please refer to the specifications or user's manual for more detailed description.
2. The difference of the two samples (Model Name: Avvio L800S, Avvio L800): Avvio L800 is single SIM card, Avvio L800S is dual SIM card. We only choose dual SIM sample to perform full tests.

1.4 Product Specification subjective to this standard

Product Specification subjective to this standard	
Tx Frequency	GSM/GPRS/EDGE: 850: 824.2 MHz ~ 848.8 MHz 1900: 1850.2 MHz ~ 1909.8MHz WCDMA: Band V: 826.4 MHz ~ 846.6 MHz Band II: 1852.4 MHz ~ 1907.6 MHz
Rx Frequency	GSM/GPRS/EDGE: 850: 869.2 MHz ~ 893.8 MHz 1900: 1930.2 MHz ~ 1989.8 MHz WCDMA: Band V: 871.4 MHz ~ 891.6 MHz Band II: 1932.4 MHz ~ 1987.6 MHz
Maximum Output Power to Antenna	GSM/GPRS/EDGE: 850: 32.43 dBm 1900: 30.35 dBm WCDMA: Band V: 23.00 dBm Band II: 23.07 dBm
Antenna Type	FPC Antenna
Type of Modulation	GSM: GMSK GPRS: GMSK EDGE: GMSK / 8PSK WCDMA: QPSK (Uplink) HSDPA: QPSK (Uplink) HSUPA: QPSK (Uplink) HSPA+ : 16QAM (Uplink) DC-HSDPA : 64QAM

1.5 Modification of EUT

No modifications are made to the EUT during all test items.



1.6 Maximum ERP/EIRP Power, Frequency Tolerance, and Emission Designator

FCC Rule	System	Type of Modulation	Maximum ERP/EIRP (W)	Frequency Tolerance (ppm)	Emission Designator
Part 22	GSM850 GSM	GMSK	0.7674	0.0084 ppm	250KGXW
Part 22	GSM850 EDGE class 8	8PSK	0.2296	0.0096 ppm	257KG7W
Part 22	WCDMA Band V RMC 12.2Kbps	QPSK	0.0834	0.0155 ppm	4M22F9W
Part 24	GSM1900 GSM	GMSK	1.6866	0.0043 ppm	250KGXW
Part 24	GSM1900 EDGE class 8	8PSK	0.7816	0.0144 ppm	255KG7W
Part 24	WCDMA Band II RMC 12.2Kbps	QPSK	0.3381	0.0133 ppm	4M22F9W

1.7 Testing Location

Test Site	SPORTON INTERNATIONAL (SHENZHEN) INC.	
Test Site Location	1F & 2F, Building A, Morning Business Center, No. 4003 ShiGu Rd., Xili Town, Nanshan District, Shenzhen, Guangdong, P. R. China TEL: +86-755-8637-9589 FAX: +86-755-8637-9595	
Test Site No.	Sporton Site No.	
	TH01-SZ	

Test Site	SPORTON INTERNATIONAL (SHENZHEN) INC.	
Test Site Location	No. 3 Building, the third floor of south, Shahe River west, Fengzeyuan warehouse, Nanshan District, Shenzhen, Guangdong, P. R. China TEL: +86-755- 3320-2398	
Test Site No.	Sporton Site No.	FCC Registration No.
	03CH01-SZ	831040



1.8 Applicable Standards

According to the specifications of the manufacturer, the EUT must comply with the requirements of the following standards:

- ♦ 47 CFR Part 2, 22(H), 24(E)
- ♦ ANSI / TIA / EIA-603-C-2004
- ♦ FCC KDB 971168 D01 Power Meas. License Digital Systems v02r02

Remark:

1. All test items were verified and recorded according to the standards and without any deviation during the test.
2. This EUT has also been tested and complied with the requirements of FCC Part 15, Subpart B, recorded in a separate test report.



2 Test Configuration of Equipment Under Test

2.1 Test Mode

Antenna port conducted and radiated test items were performed according to KDB 971168 D01 Power Meas. License Digital Systems v02r02 with maximum output power.

Radiated measurements were performed with rotating EUT in different three orthogonal test planes to find the maximum emission.

Radiated emissions were investigated as following frequency range:

1. 30 MHz to 10th harmonic for GSM850 and WCDMA Band V.
2. 30 MHz to 10th harmonic for GSM1900 and WCDMA Band II.

All modes and data rates and positions were investigated.

Test modes are chosen to be reported as the worst case configuration below:

Test Modes		
Band	Radiated TCs	Conducted TCs
GSM 850	<ul style="list-style-type: none">■ GSM Link■ EDGE class 8 Link	<ul style="list-style-type: none">■ GSM Link■ EDGE class 8 Link
GSM 1900	<ul style="list-style-type: none">■ GSM Link■ EDGE class 8 Link	<ul style="list-style-type: none">■ GSM Link■ EDGE class 8 Link
WCDMA Band V	<ul style="list-style-type: none">■ RMC 12.2Kbps Link	<ul style="list-style-type: none">■ RMC 12.2Kbps Link
WCDMA Band II	<ul style="list-style-type: none">■ RMC 12.2Kbps Link	<ul style="list-style-type: none">■ RMC 12.2Kbps Link

2.2 Connection Diagram of Test System

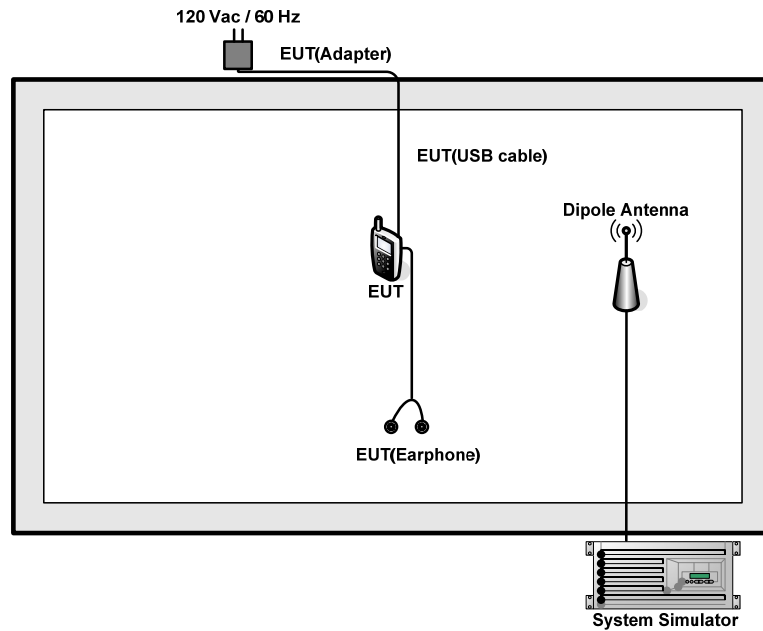

2.3 Support Unit used in test configuration

Item	Equipment	Trade Name	Model No.	FCC ID	Data Cable	Power Cord
1.	System Simulator	R&S	CMU 200	N/A	N/A	Unshielded, 1.8 m
2.	DC Power Supply	TOPWORD	3303DR	N/A	N/A	Unshielded, 1.8 m

2.4 Measurement Results Explanation Example

For all conducted test items:

The offset level is set in the spectrum analyzer to compensate the RF cable loss and attenuator factor between RF conducted output port and spectrum analyzer. With the offset compensation, the spectrum analyzer reading level will be exactly the RF output level.

The spectrum analyzer offset is derived from RF cable loss and attenuator factor.

Offset = RF cable loss + attenuator factor.

The following shows an offset computation example with RF cable loss 4.5 dB and a 10dB attenuator.

Example :

$$\begin{aligned} \text{Offset(dB)} &= \text{RF cable loss(dB)} + \text{attenuator factor(dB)} \\ &= 4.5 + 10 = 14.5 \text{ (dB)} \end{aligned}$$

3 Conducted Test Result

3.1 Measuring Instruments

See list of measuring instruments of this test report.

3.2 Test Setup

3.2.1 Conducted Output Power

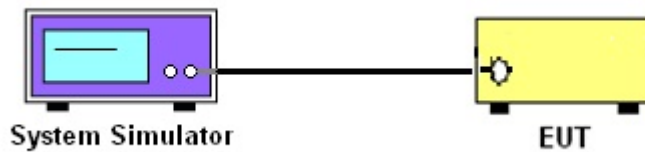

3.2.2 Peak-to-Average Ratio, Occupied Bandwidth, Conducted Band-Edge and Conducted Spurious Emission

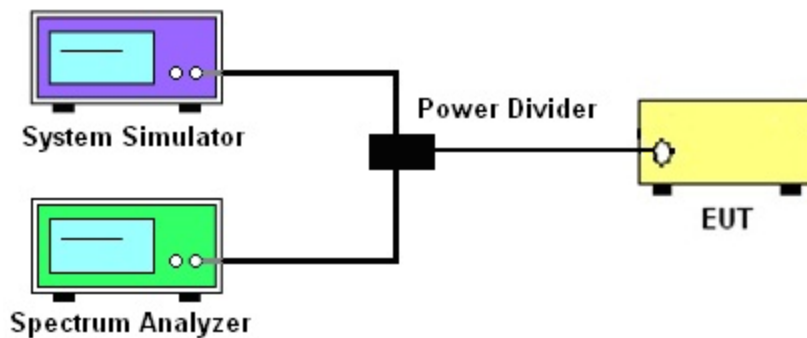

3.2.3 Frequency Stability

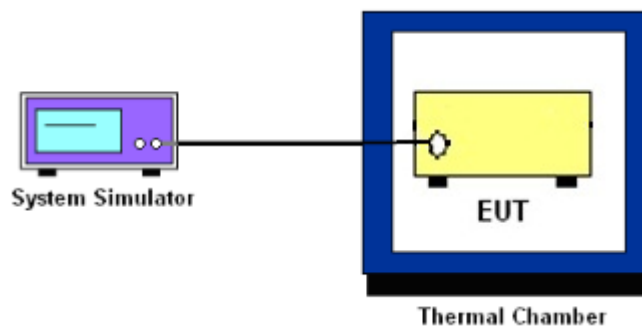

3.3 Test Result of Conducted Test

Please refer to Appendix A.



3.4 Conducted Output Power

3.4.1 Description of the Conducted Output Power

A system simulator was used to establish communication with the EUT. Its parameters were set to enforce EUT transmitting at the maximum power. The measured power in the radio frequency on the transmitter output terminals shall be reported.

3.4.2 Test Procedures

1. The transmitter output port was connected to the system simulator.
2. Set EUT at maximum power through system simulator.
3. Select lowest, middle, and highest channels for each band and different modulation.
4. Measure the maximum burst average power for GSM and maximum average power for other modulation signal.



3.5 Peak-to-Average Ratio

3.5.1 Description of the PAR Measurement

The peak-to-average ratio (PAR) of the transmission may not exceed 13 dB.

3.5.2 Test Procedures

1. The testing follows FCC KDB 971168 D01 v02r02 Section 5.7.1.
2. The EUT was connected to spectrum analyzer and system simulator via a power divider.
3. Set EUT to transmit at maximum output power.
4. When the duty cycle is less than 98%, then signal gating will be implemented on the spectrum analyzer by triggering from the system simulator.
5. Set the CCDF (Complementary Cumulative Distribution Function) option of the spectrum analyzer.
Record the maximum PAPR level associated with a probability of 0.1%.



3.6 99% Occupied Bandwidth and 26dB Bandwidth Measurement

3.6.1 Description of 99% Occupied Bandwidth and 26dB Bandwidth Measurement

The 99% occupied bandwidth is the width of a frequency band such that, below the lower and above the upper frequency limits, the mean powers emitted are each equal to a specified percentage 0.5% of the total mean transmitted power.

The emission bandwidth is defined as the width of the signal between two points, located at the two sides of the carrier frequency, outside of which all emissions are attenuated at least 26 dB below the transmitter power.

3.6.2 Test Procedures

1. The testing follows FCC KDB 971168 D01 v02r02 Section 4.2.
2. The EUT was connected to the spectrum analyzer and system simulator via a power divider.
3. The RF output of the EUT was connected to the spectrum analyzer by RF cable and attenuator. The path loss was compensated to the results for each measurement.
4. The 99% occupied bandwidth were measured, set RBW= 1% of span, VBW= 3*RBW, peak detector, trace maximum hold.
5. The 26dB bandwidth were measured, set RBW= 1% of EBW, VBW= 3*RBW, peak detector, trace maximum hold.



3.7 Conducted Band Edge

3.7.1 Description of Conducted Band Edge Measurement

The power of any emission outside of the authorized operating frequency ranges must be lower than the transmitter power (P) by a factor of at least $43 + 10 \log (P)$ dB.

3.7.2 Test Procedures

1. The testing follows FCC KDB 971168 D01 v02r02 Section 6.0.
2. The EUT was connected to the spectrum analyzer and system simulator via a power divider.
3. The RF output of EUT was connected to the spectrum analyzer by an RF cable and attenuator. The path loss was compensated to the results for each measurement.
4. The band edges of low and high channels for the highest RF powers were measured.
5. The RF fundamental frequency should be excluded against the limit line in the operating frequency band.
6. The limit line is derived from $43 + 10\log(P)$ dB below the transmitter power P(Watts)
= $P(W) - [43 + 10\log(P)]$ (dB)
= $[30 + 10\log(P)]$ (dBm) - $[43 + 10\log(P)]$ (dB)
= -13dBm.



3.8 Conducted Spurious Emission

3.8.1 Description of Conducted Spurious Emission Measurement

The power of any emission outside of the authorized operating frequency ranges must be lower than the transmitter power (P) by a factor of at least $43 + 10 \log (P)$ dB.

It is measured by means of a calibrated spectrum analyzer and scanned from 30 MHz up to a frequency including its 10th harmonic.

3.8.2 Test Procedures

1. The testing follows FCC KDB 971168 D01 v02r02 Section 6.0.
2. The EUT was connected to the spectrum analyzer and system simulator via a power divider.
3. The RF output of EUT was connected to the spectrum analyzer by an RF cable and attenuator. The path loss was compensated to the results for each measurement.
4. The middle channel for the highest RF power within the transmitting frequency was measured.
5. The conducted spurious emission for the whole frequency range was taken.
6. The RF fundamental frequency should be excluded against the limit line in the operating frequency band.
7. The limit line is derived from $43 + 10\log(P)$ dB below the transmitter power P(Watts)
= $P(W) - [43 + 10\log(P)]$ (dB)
= $[30 + 10\log(P)]$ (dBm) - $[43 + 10\log(P)]$ (dB)
= -13dBm.



3.9 Frequency Stability

3.9.1 Description of Frequency Stability Measurement

The frequency stability shall be measured by variation of ambient temperature and variation of primary supply voltage to ensure that the fundamental emission stays within the authorized frequency block. The frequency stability of the transmitter shall be maintained within $\pm 0.00025\%$ ($\pm 2.5\text{ppm}$) of the center frequency.

3.9.2 Test Procedures for Temperature Variation

1. The testing follows FCC KDB 971168 D01 v02r02 Section 9.0.
2. The EUT was set up in the thermal chamber and connected with the system simulator.
3. With power OFF, the temperature was decreased to -30°C and the EUT was stabilized before testing. Power was applied and the maximum change in frequency was recorded within one minute.
4. With power OFF, the temperature was raised in 10°C steps up to 50°C . The EUT was stabilized at each step for at least half an hour. Power was applied and the maximum frequency change was recorded within one minute.

3.9.3 Test Procedures for Voltage Variation

1. The testing follows FCC KDB 971168 D01 v02r02 Section 9.0.
2. The EUT was placed in a temperature chamber at $25\pm 5^{\circ}\text{C}$ and connected with the system simulator.
3. The power supply voltage to the EUT was varied from 85% to 115% of the nominal value measured at the input to the EUT.
4. The variation in frequency was measured for the worst case.

4 Radiated Test Items

4.1 Measuring Instruments

See list of measuring instruments of this test report.

4.2 Test Setup

4.2.1 For radiated test from 30MHz to 1GHz

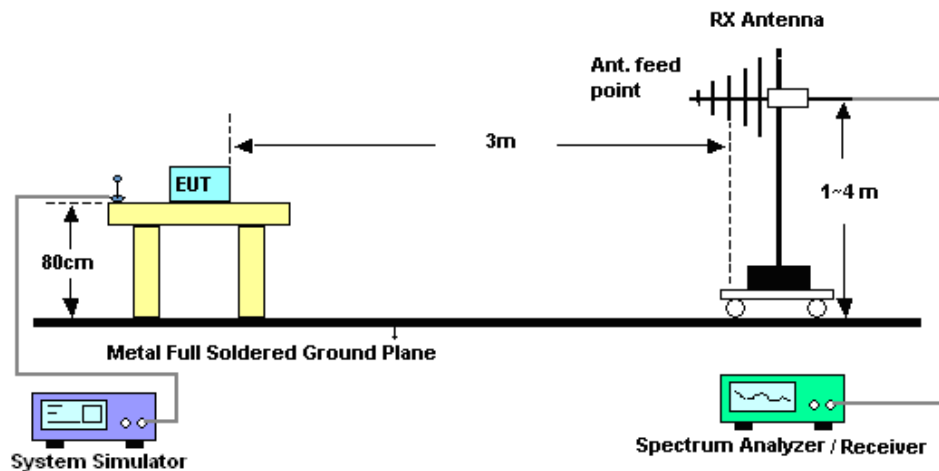

4.2.2 For radiated test above 1GHz

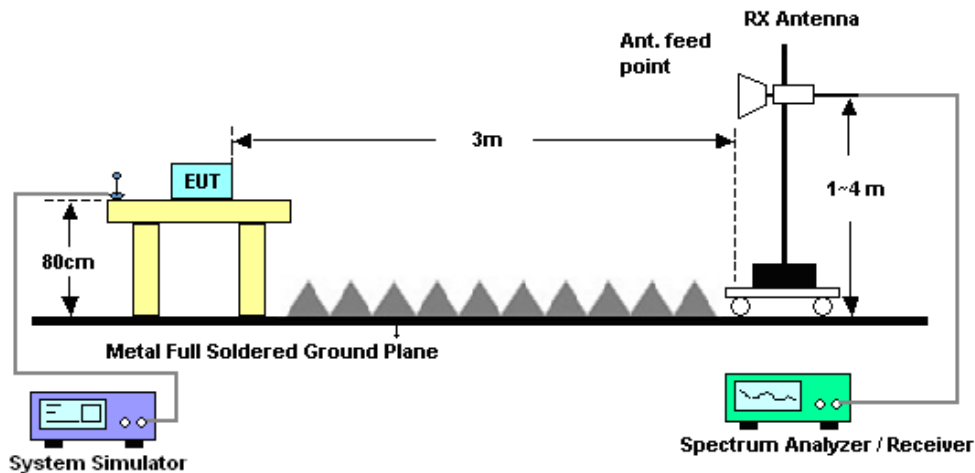

4.3 Test Result of Radiated Test

Please refer to Appendix B.



4.4 Effective Radiated Power and Effective Isotropic Radiated Power Measurement

4.4.1 Description of the ERP/EIRP Measurement

The substitution method, in ANSI / TIA / EIA-603-C-2004, was used for ERP/EIRP measurement, and the spectrum analyzer configuration follows KDB 971168 D01 Power Meas. License Digital Systems v02r02. The ERP of mobile transmitters must not exceed 7 Watts (Cellular Band) and the EIRP of mobile transmitters are limited to 2 Watts (PCS Band).

4.4.2 Test Procedures

1. The testing follows FCC KDB 971168 D01 v02r02 Section 5.2.1. (for CDMA/WCDMA), Section 5.2.2.2 (for GSM/GPRS/EDGE) and ANSI / TIA-603-C-2004 Section 2.2.17.
2. The EUT was placed on a non-conductive rotating platform 0.8 meters high in a semi-anechoic chamber. The radiated emission at the fundamental frequency was measured at 3 m with a test antenna and a spectrum analyzer with RMS detector per section 5. of KDB 971168 D01.
3. During the measurement, the system simulator parameters were set to force the EUT transmitting at maximum output power. The maximum emission was recorded from analyzer power level (LVL) from the 360 degrees rotation of the turntable and the test antenna raised and lowered over a range from 1 to 4 meters in both horizontally and vertically polarized orientations.
4. Effective Isotropic Radiated Power (EIRP) was measured by substitution method according to TIA/EIA-603-C. The EUT was replaced by the substitution antenna at same location, and then a known power from S.G. was applied into the dipole antenna through a Tx cable, and then recorded the maximum Analyzer reading through raised and lowered the test antenna. The correction factor (in dB) = S.G. - Tx Cable loss + Substitution antenna gain - Analyzer reading. Then the EUT's EIRP was calculated with the correction factor, $EIRP = LVL + \text{Correction factor}$ and $ERP = EIRP - 2.15$. Take the record of the output power at substitution antenna.



	GSM/GPRS/EDGE	WCDMA/HSPA
SPAN	500kHz	10MHz
RBW	10kHz	100kHz
VBW	30kHz	300kHz
Detector	RMS	RMS
Trace	Average	Average
Average Type	Power	Power
Sweep Count	100	100



4.5 Field Strength of Spurious Radiation Measurement

4.5.1 Description of Field Strength of Spurious Radiated Measurement

The power of any emission outside of the authorized operating frequency ranges must be attenuated below the transmitter power (P) by a factor of at least $43 + 10 \log (P)$ dB. The spectrum is scanned from 30 MHz up to a frequency including its 10th harmonic.

4.5.2 Test Procedures

1. The testing follows FCC KDB 971168 D01 v02r02 Section 5.8 and ANSI / TIA-603-C-2004 Section 2.2.12.
2. The EUT was placed on a rotatable wooden table 0.8 meters above the ground.
3. The EUT was set 3 meters from the receiving antenna, which was mounted on the antenna tower.
4. The table was rotated 360 degrees to determine the position of the highest spurious emission.
5. The height of the receiving antenna is varied between one meter and four meters to search for the maximum spurious emission for both horizontal and vertical polarizations.
6. Make the measurement with the spectrum analyzer's RBW = 1MHz, VBW = 3MHz, taking record of maximum spurious emission.
7. A horn antenna was substituted in place of the EUT and was driven by a signal generator.
8. Tune the output power of signal generator to the same emission level with EUT maximum spurious emission.
9. Taking the record of output power at antenna port.
10. Repeat step 7 to step 8 for another polarization.
11. $EIRP \text{ (dBm)} = S.G. \text{ Power} - Tx \text{ Cable Loss} + Tx \text{ Antenna Gain}$
12. $ERP \text{ (dBm)} = EIRP - 2.15$
13. The RF fundamental frequency should be excluded against the limit line in the operating frequency band.
14. The limit line is derived from $43 + 10\log(P)$ dB below the transmitter power P(Watts)
= $P(W) - [43 + 10\log(P)] \text{ (dB)}$
= $[30 + 10\log(P)] \text{ (dBm)} - [43 + 10\log(P)] \text{ (dB)}$
= -13dBm.



5 List of Measuring Equipment

Instrument	Manufacturer	Model No.	Serial No.	Characteristics	Calibration Date	Test Date	Due Date	Remark
Spectrum Analyzer	R&S	FSP30	101400	9kHz~30GHz	Jan. 28, 2015	Aug. 12, 2015	Jan. 27, 2016	Conducted (TH01-SZ)
Thermal Chamber	Ten Billion Hongzhangroup	LP-150U	H2014081803	-40~+150°C	Aug. 07, 2015	Aug. 12, 2015	Aug. 06, 2016	Conducted (TH01-SZ)
EMI Test Receiver&SA	Agilent Technologies	N9038A	MY52260185	20Hz~26.5GHz	May 26, 2015	Aug. 29, 2015	May 25, 2016	Radiation (03CH01-SZ)
Spectrum Analyzer	R&S	FSV40	101041	10kHz~40GHz;Max 30dBm	Sep. 25, 2014	Aug. 29, 2015	Sep. 24, 2015	Radiation (03CH01-SZ)
Bilog Antenna	TeseQ	CBL6112D	23188	30MHz~2GHz	Nov. 07, 2014	Aug. 29, 2015	Nov. 06, 2015	Radiation (03CH01-SZ)
Double Ridge Horn Antenna	ETS-Lindgren	3117	00119436	1GHz~18GHz	Oct. 15, 2014	Aug. 29, 2015	Oct. 14, 2015	Radiation (03CH01-SZ)
SHF-EHF Horn	com-power	AH-840	101071	18GHz~40GHz	Aug. 17, 2015	Aug. 29, 2015	Aug. 16, 2016	Radiation (03CH01-SZ)
Amplifier	ADVANTEST	BB525C	E9007003	9kHz~3000MHz / 30 dB	Jan. 28, 2015	Aug. 29, 2015	Jan. 27, 2016	Radiation (03CH01-SZ)
Amplifier	Yiai	AV3860B	04030	2GHz~26.5GHz	May 05, 2015	Aug. 29, 2015	May 04, 2016	Radiation (03CH01-SZ)
Amplifier	Agilent Technologies	83017A	MY39501302	500MHz~26.5GHz	Jan. 28, 2015	Aug. 29, 2015	Jan. 27, 2016	Radiation (03CH01-SZ)
AC Power Source	Chroma	61601	616010001985	N/A	NCR	Aug. 29, 2015	NCR	Radiation (03CH01-SZ)
Turn Table	EM	EM1000	N/A	0~360 degree	NCR	Aug. 29, 2015	NCR	Radiation (03CH01-SZ)
Antenna Mast	EM	EM1000	N/A	1 m~4 m	NCR	Aug. 29, 2015	NCR	Radiation (03CH01-SZ)



6 Uncertainty of Evaluation

Uncertainty of Radiated Emission Measurement (30 MHz ~ 1000 MHz)

Measuring Uncertainty for a Level of Confidence of 95% ($U = 2Uc(y)$)	3.9dB
---	-------



Appendix A. Test Results of Conducted Test

Conducted Output Power(Average power)

Conducted Power (*Unit: dBm)						
Band	GSM850			GSM1900		
Channel	128	189	251	512	661	810
Frequency	824.2	836.4	848.8	1850.2	1880.0	1909.8
GSM	32.43	32.30	32.09	30.12	30.20	30.35
GPRS class 8	32.41	32.29	32.08	30.08	30.18	30.33
GPRS class 10	32.08	31.94	31.73	29.26	29.40	29.69
GPRS class 11	31.00	30.81	30.60	27.25	27.48	27.94
GPRS class 12	29.87	29.59	29.35	26.11	26.36	26.82
EGPRS class 8	27.58	27.54	27.05	26.70	26.27	26.18
EGPRS class 10	26.60	26.54	26.06	25.28	25.37	25.37
EGPRS class 11	24.79	24.77	24.29	23.48	23.54	23.36
EGPRS class 12	23.74	23.73	23.23	22.51	22.58	22.35

Conducted Power (*Unit: dBm)						
Band	WCDMA Band V			WCDMA Band II		
Channel	4132	4182	4233	9262	9400	9538
Frequency	826.4	836.4	846.6	1852.4	1880	1907.6
AMR 12.2Kbps	22.91	22.77	22.98	21.94	21.63	22.89
RMC 12.2K	22.95	22.78	23.00	23.07	22.98	23.01
HSDPA Subtest-1	21.40	21.49	21.91	21.33	20.96	21.37
HSDPA Subtest-2	21.46	21.54	21.95	21.30	21.02	21.36
HSDPA Subtest-3	21.02	21.04	21.44	20.84	20.51	20.92
HSDPA Subtest-4	20.97	21.06	21.45	20.83	20.51	20.90
DC-HSDPA Subtest-1	21.43	21.38	21.73	21.36	20.89	21.30
DC-HSDPA Subtest-2	21.42	21.37	21.70	21.32	20.89	21.25
DC-HSDPA Subtest-3	20.90	20.87	21.16	20.82	20.37	20.73
DC-HSDPA Subtest-4	20.91	20.87	21.21	20.83	20.37	20.74
HSUPA Subtest-1	19.44	19.48	19.87	19.35	19.03	19.35
HSUPA Subtest-2	19.46	19.47	19.92	19.33	18.94	19.38
HSUPA Subtest-3	20.46	20.49	20.91	20.35	19.95	20.39
HSUPA Subtest-4	18.86	18.95	19.32	18.79	18.54	18.91
HSUPA Subtest-5	21.40	21.50	21.80	21.30	20.90	21.30
HSPA+ (16QAM) Subtest-1	20.42	20.41	20.75	20.30	19.95	20.35



A1. GSM

Peak-to-Average Ratio

Mode	GSM850		Limit: 13dB
Mod.	GSM	EDGE class 8	Result
Lowest CH	0.20	2.92	PASS
Middle CH	0.24	2.76	
Highest CH	0.24	3.04	

Mode	GSM1900		Limit: 13dB
Mod.	GSM	EDGE class 8	Result
Lowest CH	0.24	2.84	PASS
Middle CH	0.20	2.88	
Highest CH	0.24	2.88	

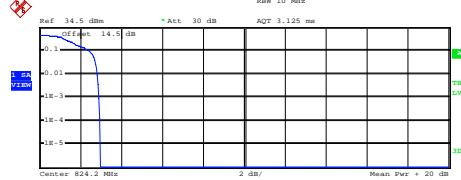
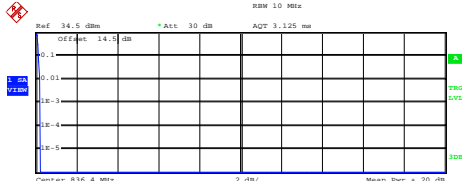
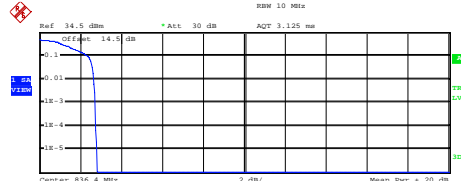
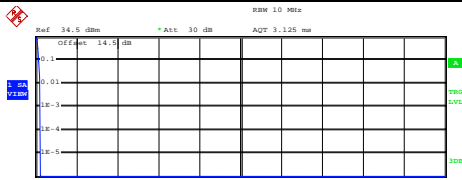
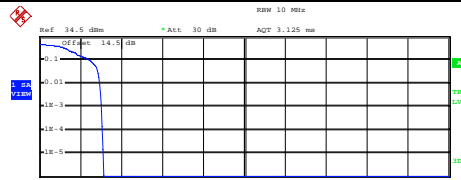

GSM850 (GSM)	GSM850 (EDGE class 8)																
<p align="center">Lowest Channel</p>  <p>Center 824.2 MHz 2 dB/ Mean Pwr + 20 dB</p> <p>Complementary Cumulative Distribution Function (100000 samples)</p> <p>Trace 1</p> <p>Mean 32.75 dBm Peak 32.99 dBm Crest 0.24 dB</p> <table border="0"> <tr><td>10 %</td><td>0.16 dB</td></tr> <tr><td>1 %</td><td>0.20 dB</td></tr> <tr><td>.1 %</td><td>0.20 dB</td></tr> <tr><td>.01 %</td><td>0.24 dB</td></tr> </table> <p>Date: 12.AUG.2015 18:50:05</p>	10 %	0.16 dB	1 %	0.20 dB	.1 %	0.20 dB	.01 %	0.24 dB	<p align="center">Lowest Channel</p>  <p>Center 824.2 MHz 2 dB/ Mean Pwr + 20 dB</p> <p>Complementary Cumulative Distribution Function (100000 samples)</p> <p>Trace 1</p> <p>Mean 26.22 dBm Peak 29.18 dBm Crest 2.96 dB</p> <table border="0"> <tr><td>10 %</td><td>2.44 dB</td></tr> <tr><td>1 %</td><td>2.84 dB</td></tr> <tr><td>.1 %</td><td>2.92 dB</td></tr> <tr><td>.01 %</td><td>2.96 dB</td></tr> </table> <p>Date: 12.AUG.2015 18:27:18</p>	10 %	2.44 dB	1 %	2.84 dB	.1 %	2.92 dB	.01 %	2.96 dB
10 %	0.16 dB																
1 %	0.20 dB																
.1 %	0.20 dB																
.01 %	0.24 dB																
10 %	2.44 dB																
1 %	2.84 dB																
.1 %	2.92 dB																
.01 %	2.96 dB																
<p align="center">Middle Channel</p>  <p>Center 836.4 MHz 2 dB/ Mean Pwr + 20 dB</p> <p>Complementary Cumulative Distribution Function (100000 samples)</p> <p>Trace 1</p> <p>Mean 32.57 dBm Peak 32.78 dBm Crest 0.21 dB</p> <table border="0"> <tr><td>10 %</td><td>0.16 dB</td></tr> <tr><td>1 %</td><td>0.20 dB</td></tr> <tr><td>.1 %</td><td>0.24 dB</td></tr> <tr><td>.01 %</td><td>0.24 dB</td></tr> </table> <p>Date: 12.AUG.2015 18:50:40</p>	10 %	0.16 dB	1 %	0.20 dB	.1 %	0.24 dB	.01 %	0.24 dB	<p align="center">Middle Channel</p>  <p>Center 836.4 MHz 2 dB/ Mean Pwr + 20 dB</p> <p>Complementary Cumulative Distribution Function (100000 samples)</p> <p>Trace 1</p> <p>Mean 26.23 dBm Peak 29.04 dBm Crest 2.81 dB</p> <table border="0"> <tr><td>10 %</td><td>2.36 dB</td></tr> <tr><td>1 %</td><td>2.68 dB</td></tr> <tr><td>.1 %</td><td>2.76 dB</td></tr> <tr><td>.01 %</td><td>2.76 dB</td></tr> </table> <p>Date: 12.AUG.2015 18:27:33</p>	10 %	2.36 dB	1 %	2.68 dB	.1 %	2.76 dB	.01 %	2.76 dB
10 %	0.16 dB																
1 %	0.20 dB																
.1 %	0.24 dB																
.01 %	0.24 dB																
10 %	2.36 dB																
1 %	2.68 dB																
.1 %	2.76 dB																
.01 %	2.76 dB																
<p align="center">Highest Channel</p>  <p>Center 848.8 MHz 2 dB/ Mean Pwr + 20 dB</p> <p>Complementary Cumulative Distribution Function (100000 samples)</p> <p>Trace 1</p> <p>Mean 32.43 dBm Peak 32.64 dBm Crest 0.21 dB</p> <table border="0"> <tr><td>10 %</td><td>0.16 dB</td></tr> <tr><td>1 %</td><td>0.24 dB</td></tr> <tr><td>.1 %</td><td>0.24 dB</td></tr> <tr><td>.01 %</td><td>0.24 dB</td></tr> </table> <p>Date: 12.AUG.2015 18:50:53</p>	10 %	0.16 dB	1 %	0.24 dB	.1 %	0.24 dB	.01 %	0.24 dB	<p align="center">Highest Channel</p>  <p>Center 848.8 MHz 2 dB/ Mean Pwr + 20 dB</p> <p>Complementary Cumulative Distribution Function (100000 samples)</p> <p>Trace 1</p> <p>Mean 25.68 dBm Peak 28.83 dBm Crest 3.15 dB</p> <table border="0"> <tr><td>10 %</td><td>2.48 dB</td></tr> <tr><td>1 %</td><td>2.96 dB</td></tr> <tr><td>.1 %</td><td>3.04 dB</td></tr> <tr><td>.01 %</td><td>3.08 dB</td></tr> </table> <p>Date: 12.AUG.2015 18:27:46</p>	10 %	2.48 dB	1 %	2.96 dB	.1 %	3.04 dB	.01 %	3.08 dB
10 %	0.16 dB																
1 %	0.24 dB																
.1 %	0.24 dB																
.01 %	0.24 dB																
10 %	2.48 dB																
1 %	2.96 dB																
.1 %	3.04 dB																
.01 %	3.08 dB																



GSM1900 (GSM)	GSM1900 (EDGE class 8)																
<p align="center">Lowest Channel</p> <p>Complementary Cumulative Distribution Function (100000 samples) Trace 1 Mean 29.31 dBm Peak 29.54 dBm Crest 0.23 dB</p> <table border="1"> <tr><td>10 %</td><td>0.16 dB</td></tr> <tr><td>1 %</td><td>0.16 dB</td></tr> <tr><td>.1 %</td><td>0.24 dB</td></tr> <tr><td>.01 %</td><td>0.24 dB</td></tr> </table> <p>Date: 12.AUG.2015 19:08:00</p>	10 %	0.16 dB	1 %	0.16 dB	.1 %	0.24 dB	.01 %	0.24 dB	<p align="center">Lowest Channel</p> <p>Complementary Cumulative Distribution Function (100000 samples) Trace 1 Mean 24.60 dBm Peak 27.49 dBm Crest 2.89 dB</p> <table border="1"> <tr><td>10 %</td><td>2.36 dB</td></tr> <tr><td>1 %</td><td>2.80 dB</td></tr> <tr><td>.1 %</td><td>2.84 dB</td></tr> <tr><td>.01 %</td><td>2.92 dB</td></tr> </table> <p>Date: 12.AUG.2015 18:15:54</p>	10 %	2.36 dB	1 %	2.80 dB	.1 %	2.84 dB	.01 %	2.92 dB
10 %	0.16 dB																
1 %	0.16 dB																
.1 %	0.24 dB																
.01 %	0.24 dB																
10 %	2.36 dB																
1 %	2.80 dB																
.1 %	2.84 dB																
.01 %	2.92 dB																
<p align="center">Middle Channel</p> <p>Complementary Cumulative Distribution Function (100000 samples) Trace 1 Mean 29.28 dBm Peak 29.54 dBm Crest 0.26 dB</p> <table border="1"> <tr><td>10 %</td><td>0.16 dB</td></tr> <tr><td>1 %</td><td>0.20 dB</td></tr> <tr><td>.1 %</td><td>0.20 dB</td></tr> <tr><td>.01 %</td><td>0.24 dB</td></tr> </table> <p>Date: 12.AUG.2015 19:08:14</p>	10 %	0.16 dB	1 %	0.20 dB	.1 %	0.20 dB	.01 %	0.24 dB	<p align="center">Middle Channel</p> <p>Complementary Cumulative Distribution Function (100000 samples) Trace 1 Mean 24.72 dBm Peak 27.63 dBm Crest 2.92 dB</p> <table border="1"> <tr><td>10 %</td><td>2.44 dB</td></tr> <tr><td>1 %</td><td>2.84 dB</td></tr> <tr><td>.1 %</td><td>2.88 dB</td></tr> <tr><td>.01 %</td><td>2.92 dB</td></tr> </table> <p>Date: 12.AUG.2015 18:16:19</p>	10 %	2.44 dB	1 %	2.84 dB	.1 %	2.88 dB	.01 %	2.92 dB
10 %	0.16 dB																
1 %	0.20 dB																
.1 %	0.20 dB																
.01 %	0.24 dB																
10 %	2.44 dB																
1 %	2.84 dB																
.1 %	2.88 dB																
.01 %	2.92 dB																
<p align="center">Highest Channel</p> <p>Complementary Cumulative Distribution Function (100000 samples) Trace 1 Mean 29.50 dBm Peak 29.75 dBm Crest 0.25 dB</p> <table border="1"> <tr><td>10 %</td><td>0.16 dB</td></tr> <tr><td>1 %</td><td>0.20 dB</td></tr> <tr><td>.1 %</td><td>0.24 dB</td></tr> <tr><td>.01 %</td><td>0.28 dB</td></tr> </table> <p>Date: 12.AUG.2015 19:08:44</p>	10 %	0.16 dB	1 %	0.20 dB	.1 %	0.24 dB	.01 %	0.28 dB	<p align="center">Highest Channel</p> <p>Complementary Cumulative Distribution Function (100000 samples) Trace 1 Mean 24.70 dBm Peak 27.63 dBm Crest 2.94 dB</p> <table border="1"> <tr><td>10 %</td><td>2.44 dB</td></tr> <tr><td>1 %</td><td>2.80 dB</td></tr> <tr><td>.1 %</td><td>2.88 dB</td></tr> <tr><td>.01 %</td><td>2.92 dB</td></tr> </table> <p>Date: 12.AUG.2015 18:16:36</p>	10 %	2.44 dB	1 %	2.80 dB	.1 %	2.88 dB	.01 %	2.92 dB
10 %	0.16 dB																
1 %	0.20 dB																
.1 %	0.24 dB																
.01 %	0.28 dB																
10 %	2.44 dB																
1 %	2.80 dB																
.1 %	2.88 dB																
.01 %	2.92 dB																



26dB Bandwidth

Mode	GSM850	
Mod.	GSM	EDGE class 8
Lowest CH	0.297	0.308
Middle CH	0.311	0.315
Highest CH	0.318	0.311

Mode	GSM1900	
Mod.	GSM	EDGE class 8
Lowest CH	0.301	0.308
Middle CH	0.313	0.309
Highest CH	0.311	0.314



GSM850 (GSM)

Lowest Channel

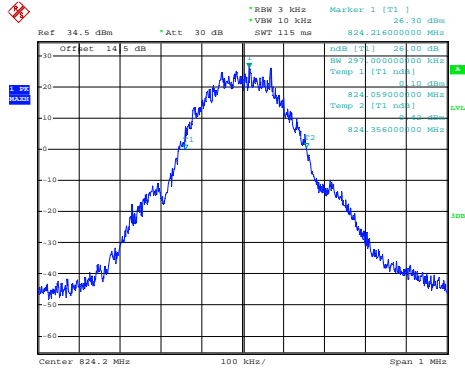

Date: 12.AUG.2015 18:51:28

GSM850 (EDGE class 8)

Lowest Channel

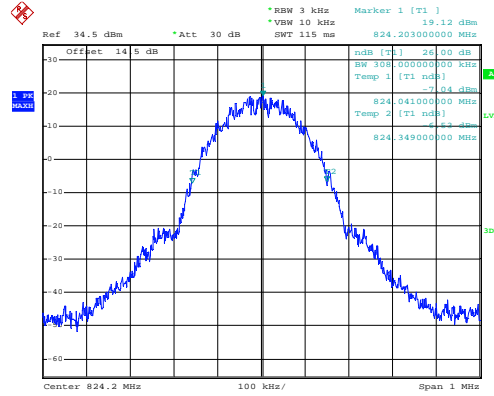

Date: 12.AUG.2015 17:39:06

Middle Channel

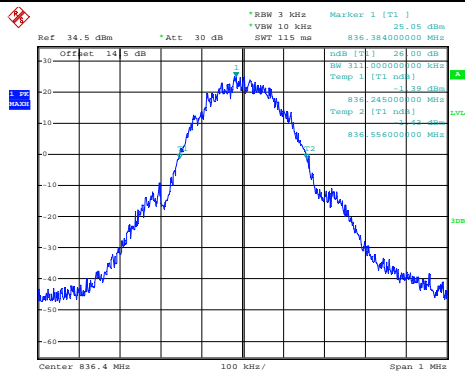

Date: 12.AUG.2015 18:51:56

Middle Channel

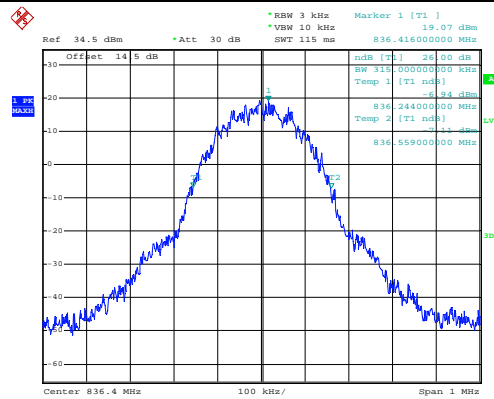

Date: 12.AUG.2015 17:39:34

Highest Channel

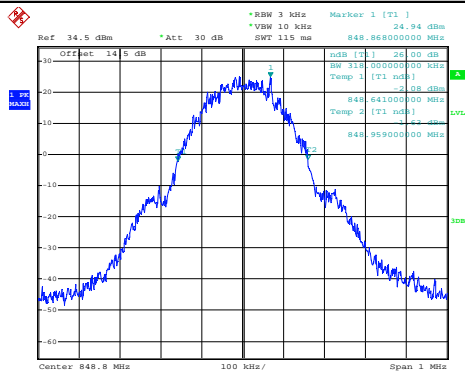

Date: 12.AUG.2015 18:52:24

Highest Channel

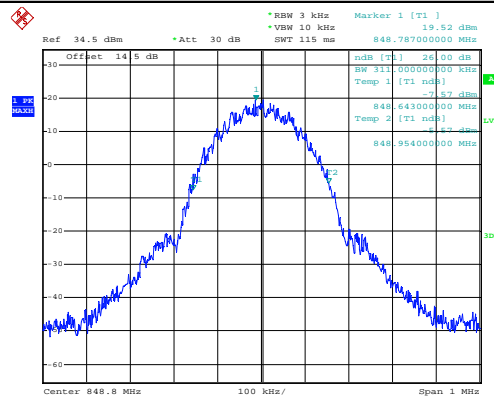

Date: 12.AUG.2015 17:40:02



GSM1900 (GSM)

Lowest Channel

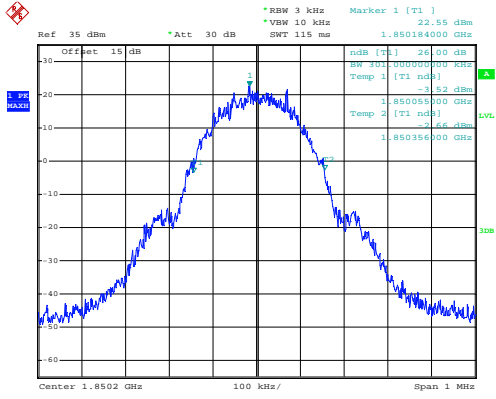

Date: 12.AUG.2015 18:59:42

GSM1900 (EDGE class 8)

Lowest Channel

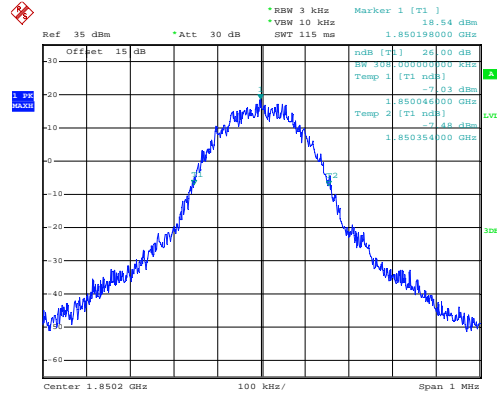

Date: 12.AUG.2015 17:47:46

Middle Channel

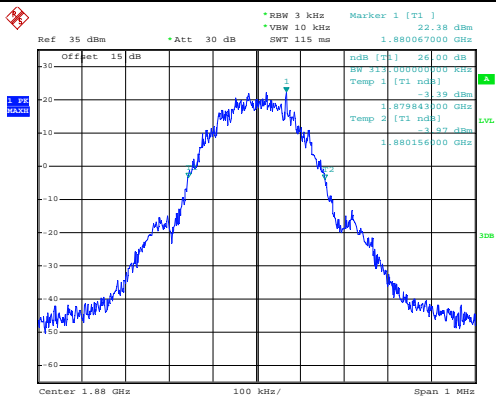

Date: 12.AUG.2015 19:00:10

Middle Channel

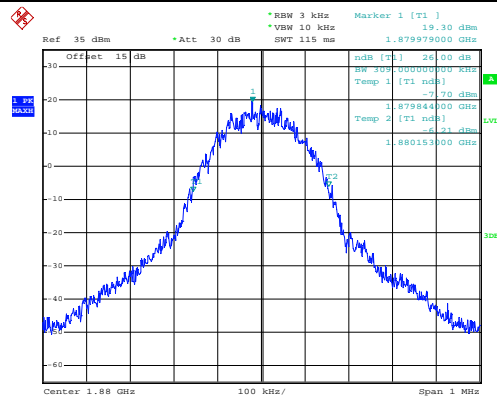

Date: 12.AUG.2015 17:48:14

Highest Channel

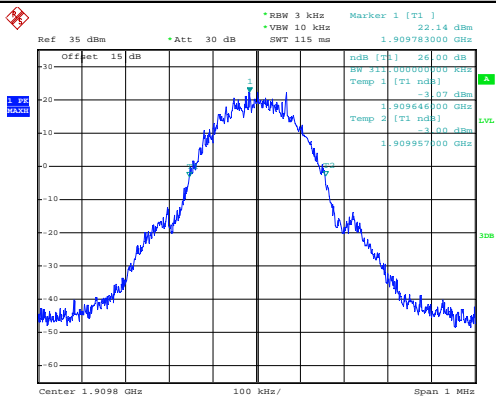

Date: 12.AUG.2015 19:00:38

Highest Channel

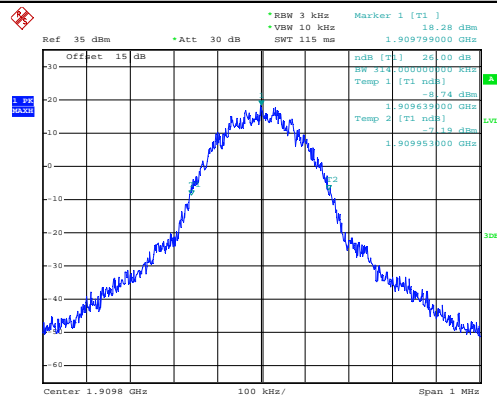

Date: 12.AUG.2015 17:48:42



Occupied Bandwidth

Mode	GSM850	
Mod.	GSM	EDGE class 8
Lowest CH	0.246	0.257
Middle CH	0.244	0.255
Highest CH	0.250	0.255

Mode	GSM1900	
Mod.	GSM	EDGE class 8
Lowest CH	0.250	0.255
Middle CH	0.246	0.253
Highest CH	0.245	0.251



GSM850 (GSM)

Lowest Channel

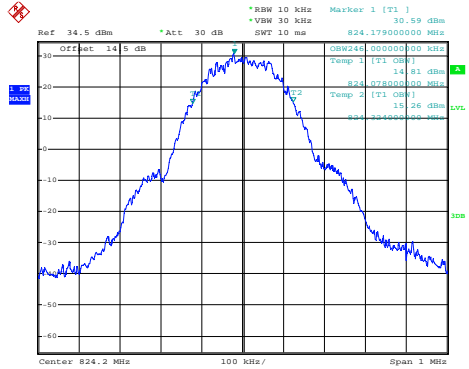

Date: 12.AUG.2015 18:53:11

GSM850 (EDGE class 8)

Lowest Channel

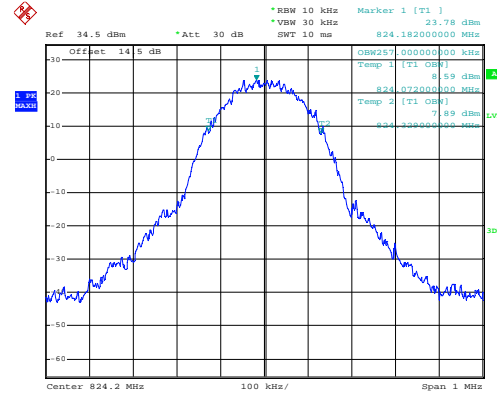

Date: 12.AUG.2015 17:40:36

Middle Channel

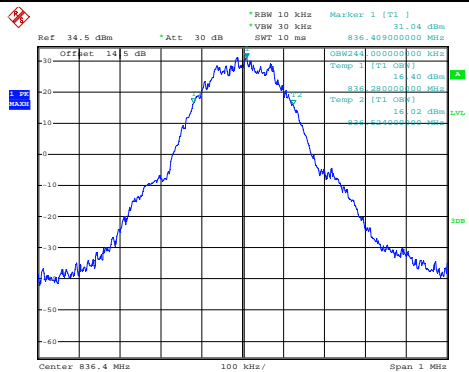

Date: 12.AUG.2015 18:53:39

Middle Channel

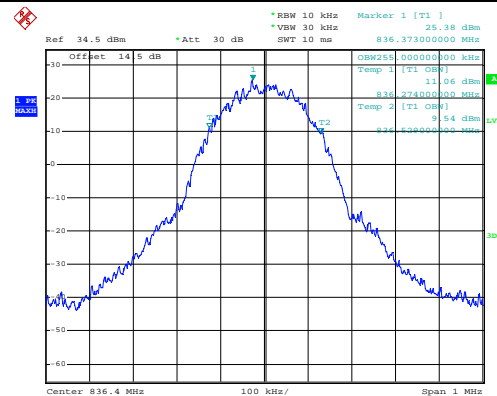

Date: 12.AUG.2015 17:41:04

Highest Channel

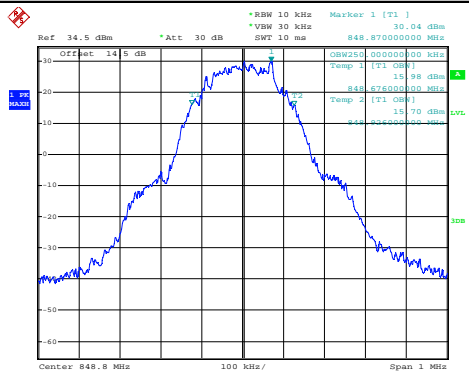

Date: 12.AUG.2015 18:54:07

Highest Channel

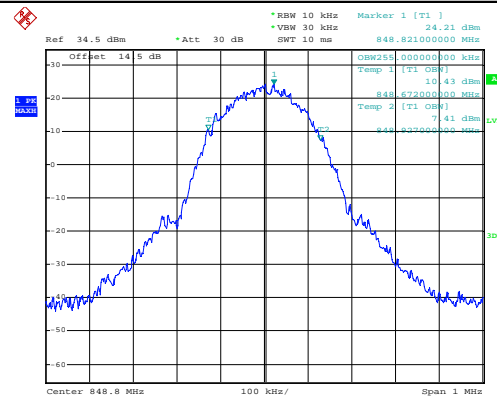

Date: 12.AUG.2015 17:41:32



GSM1900 (GSM)

Lowest Channel

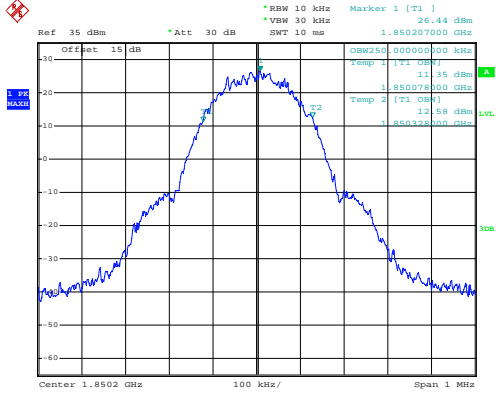

Date: 12.AUG.2015 19:01:34

GSM1900 (EDGE class 8)

Lowest Channel

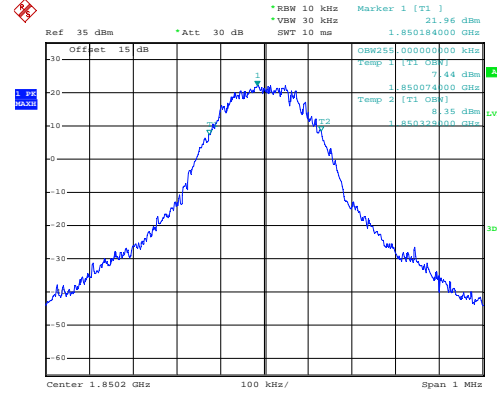

Date: 12.AUG.2015 17:52:09

Middle Channel

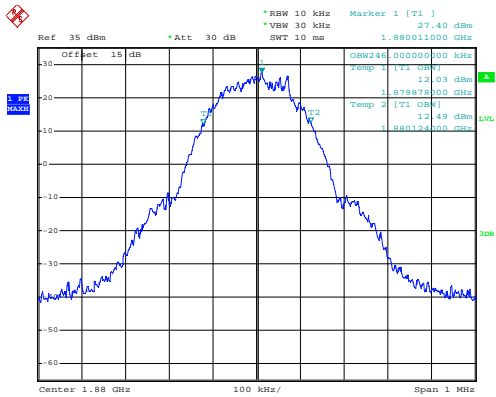

Date: 12.AUG.2015 19:02:02

Middle Channel

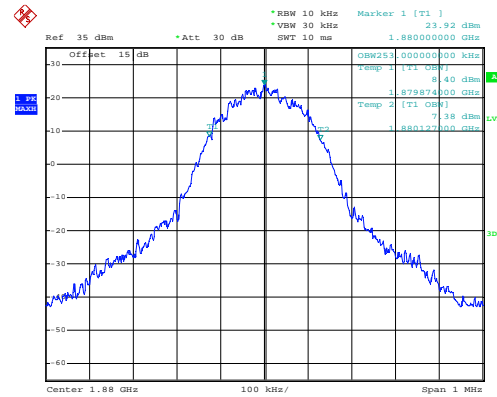

Date: 12.AUG.2015 17:52:37

Highest Channel

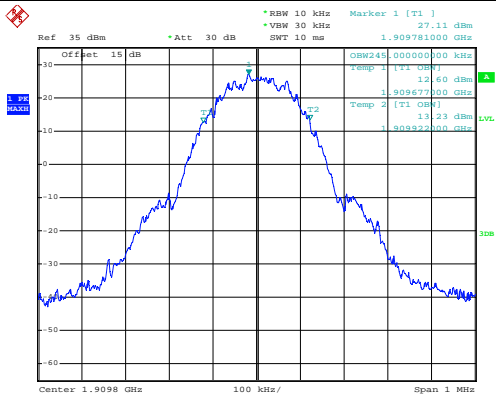

Date: 12.AUG.2015 19:02:30

Highest Channel

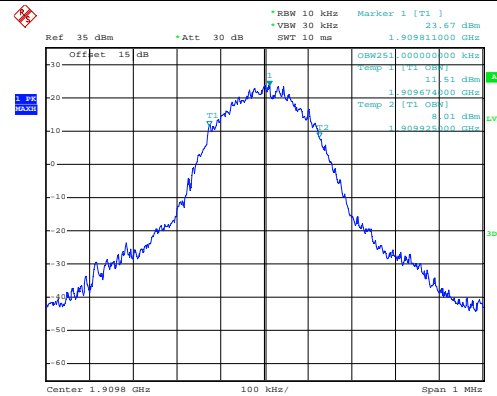

Date: 12.AUG.2015 17:53:05



Conducted Band Edge

GSM850 (GSM)

Lowest Band Edge

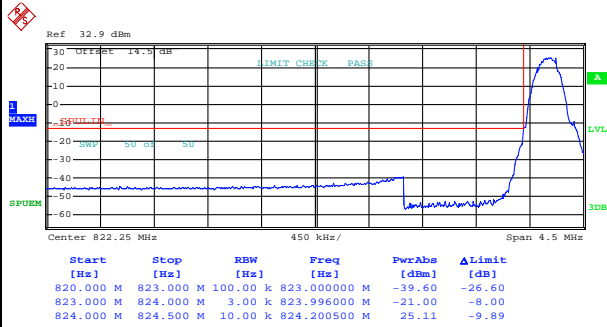

Date: 12.AUG.2015 18:56:10

Highest Band Edge

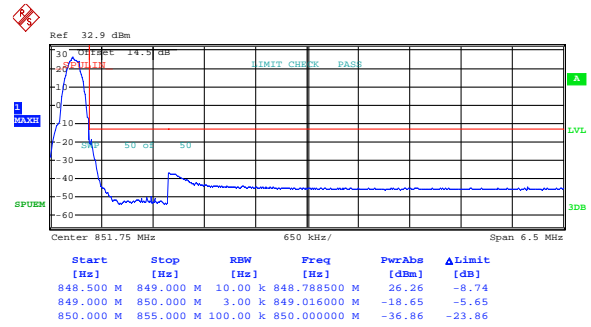

Date: 12.AUG.2015 18:57:37

GSM850 (EDGE class 8)

Lowest Band Edge

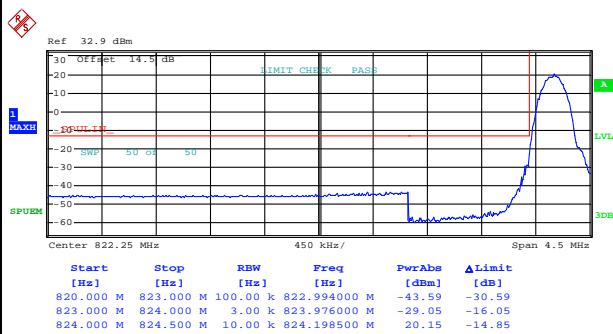

Date: 12.AUG.2015 17:43:13

Highest Band Edge

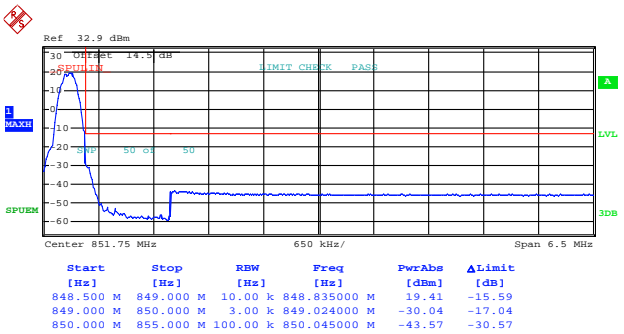

Date: 12.AUG.2015 17:44:40



GSM1900 (GSM)

Lowest Band Edge

Highest Band Edge

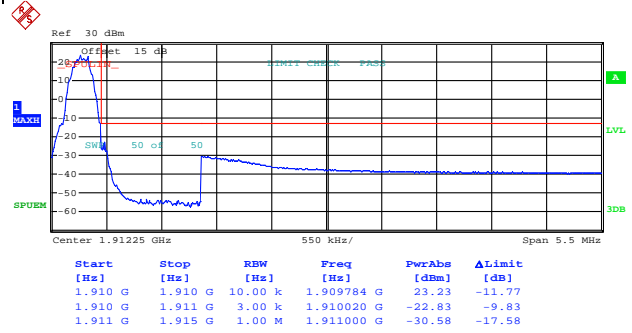
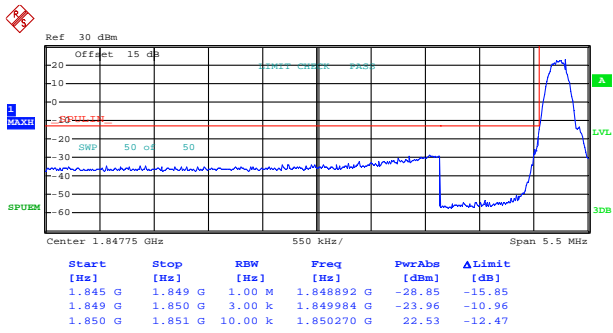

Date: 12.AUG.2015 19:04:01

Date: 12.AUG.2015 19:05:27

GSM1900 (EDGE class 8)

Lowest Band Edge

Highest Band Edge

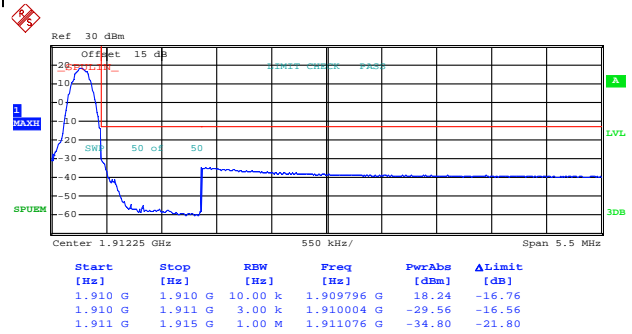
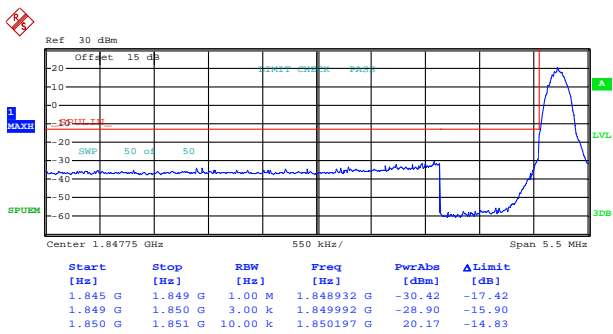

Date: 12.AUG.2015 17:54:43

Date: 12.AUG.2015 17:56:10

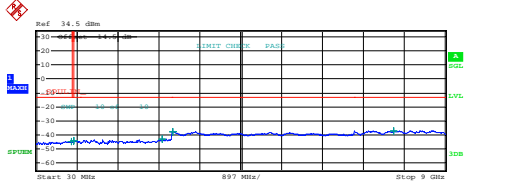
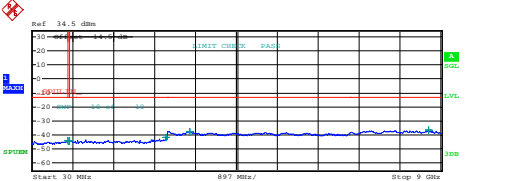
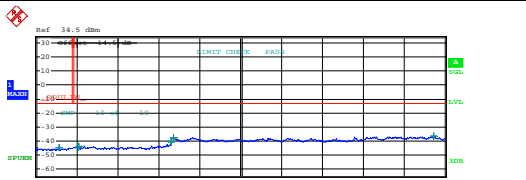
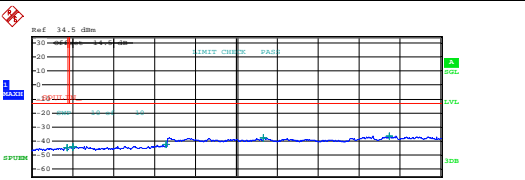
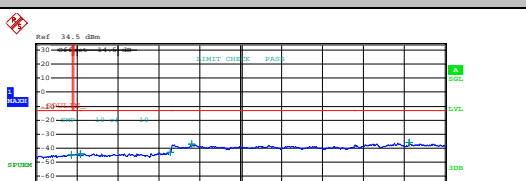
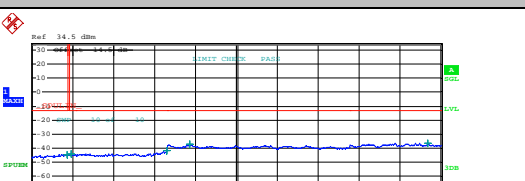

Conducted Spurious Emission

GSM850 (GSM)	GSM850 (EDGE class 8)																																																																								
Lowest Channel	Lowest Channel																																																																								
 <table border="1" data-bbox="239 649 702 739"> <thead> <tr> <th>Start [Hz]</th> <th>Stop [Hz]</th> <th>RBW [Hz]</th> <th>Freq [Hz]</th> <th>PwrAbs [dBm]</th> <th>ΔLimit [dB]</th> </tr> </thead> <tbody> <tr> <td>30.000 M</td> <td>820.000 M</td> <td>1.00 M</td> <td>807.155000 M</td> <td>-44.47</td> <td>-31.47</td> </tr> <tr> <td>855.000 M</td> <td>1.000 G</td> <td>1.00 M</td> <td>862.975001 M</td> <td>-44.44</td> <td>-31.44</td> </tr> <tr> <td>1.000 G</td> <td>3.000 G</td> <td>1.00 M</td> <td>2.788000 G</td> <td>-42.83</td> <td>-29.83</td> </tr> <tr> <td>3.000 G</td> <td>7.000 G</td> <td>1.00 M</td> <td>3.630000 G</td> <td>-37.55</td> <td>-24.55</td> </tr> <tr> <td>7.000 G</td> <td>9.000 G</td> <td>1.00 M</td> <td>7.862000 G</td> <td>-36.90</td> <td>-23.90</td> </tr> </tbody> </table> <p>Date: 12.AUG.2015 18:46:50</p>	Start [Hz]	Stop [Hz]	RBW [Hz]	Freq [Hz]	PwrAbs [dBm]	ΔLimit [dB]	30.000 M	820.000 M	1.00 M	807.155000 M	-44.47	-31.47	855.000 M	1.000 G	1.00 M	862.975001 M	-44.44	-31.44	1.000 G	3.000 G	1.00 M	2.788000 G	-42.83	-29.83	3.000 G	7.000 G	1.00 M	3.630000 G	-37.55	-24.55	7.000 G	9.000 G	1.00 M	7.862000 G	-36.90	-23.90	 <table border="1" data-bbox="893 649 1356 739"> <thead> <tr> <th>Start [Hz]</th> <th>Stop [Hz]</th> <th>RBW [Hz]</th> <th>Freq [Hz]</th> <th>PwrAbs [dBm]</th> <th>ΔLimit [dB]</th> </tr> </thead> <tbody> <tr> <td>30.000 M</td> <td>820.000 M</td> <td>1.00 M</td> <td>817.630000 M</td> <td>-44.40</td> <td>-31.40</td> </tr> <tr> <td>855.000 M</td> <td>1.000 G</td> <td>1.00 M</td> <td>864.135001 M</td> <td>-44.24</td> <td>-31.24</td> </tr> <tr> <td>1.000 G</td> <td>3.000 G</td> <td>1.00 M</td> <td>2.970000 G</td> <td>-41.57</td> <td>-28.57</td> </tr> <tr> <td>3.000 G</td> <td>7.000 G</td> <td>1.00 M</td> <td>3.492000 G</td> <td>-37.49</td> <td>-24.49</td> </tr> <tr> <td>7.000 G</td> <td>9.000 G</td> <td>1.00 M</td> <td>8.734500 G</td> <td>-36.79</td> <td>-23.79</td> </tr> </tbody> </table> <p>Date: 12.AUG.2015 18:32:52</p>	Start [Hz]	Stop [Hz]	RBW [Hz]	Freq [Hz]	PwrAbs [dBm]	ΔLimit [dB]	30.000 M	820.000 M	1.00 M	817.630000 M	-44.40	-31.40	855.000 M	1.000 G	1.00 M	864.135001 M	-44.24	-31.24	1.000 G	3.000 G	1.00 M	2.970000 G	-41.57	-28.57	3.000 G	7.000 G	1.00 M	3.492000 G	-37.49	-24.49	7.000 G	9.000 G	1.00 M	8.734500 G	-36.79	-23.79
Start [Hz]	Stop [Hz]	RBW [Hz]	Freq [Hz]	PwrAbs [dBm]	ΔLimit [dB]																																																																				
30.000 M	820.000 M	1.00 M	807.155000 M	-44.47	-31.47																																																																				
855.000 M	1.000 G	1.00 M	862.975001 M	-44.44	-31.44																																																																				
1.000 G	3.000 G	1.00 M	2.788000 G	-42.83	-29.83																																																																				
3.000 G	7.000 G	1.00 M	3.630000 G	-37.55	-24.55																																																																				
7.000 G	9.000 G	1.00 M	7.862000 G	-36.90	-23.90																																																																				
Start [Hz]	Stop [Hz]	RBW [Hz]	Freq [Hz]	PwrAbs [dBm]	ΔLimit [dB]																																																																				
30.000 M	820.000 M	1.00 M	817.630000 M	-44.40	-31.40																																																																				
855.000 M	1.000 G	1.00 M	864.135001 M	-44.24	-31.24																																																																				
1.000 G	3.000 G	1.00 M	2.970000 G	-41.57	-28.57																																																																				
3.000 G	7.000 G	1.00 M	3.492000 G	-37.49	-24.49																																																																				
7.000 G	9.000 G	1.00 M	8.734500 G	-36.79	-23.79																																																																				
Middle Channel	Middle Channel																																																																								
 <table border="1" data-bbox="239 1162 702 1252"> <thead> <tr> <th>Start [Hz]</th> <th>Stop [Hz]</th> <th>RBW [Hz]</th> <th>Freq [Hz]</th> <th>PwrAbs [dBm]</th> <th>ΔLimit [dB]</th> </tr> </thead> <tbody> <tr> <td>30.000 M</td> <td>820.000 M</td> <td>1.00 M</td> <td>534.810000 M</td> <td>-44.55</td> <td>-31.55</td> </tr> <tr> <td>855.000 M</td> <td>1.000 G</td> <td>1.00 M</td> <td>964.330008 M</td> <td>-44.05</td> <td>-31.05</td> </tr> <tr> <td>1.000 G</td> <td>3.000 G</td> <td>1.00 M</td> <td>2.994000 G</td> <td>-40.50</td> <td>-27.50</td> </tr> <tr> <td>3.000 G</td> <td>7.000 G</td> <td>1.00 M</td> <td>3.038000 G</td> <td>-37.79</td> <td>-24.79</td> </tr> <tr> <td>7.000 G</td> <td>9.000 G</td> <td>1.00 M</td> <td>8.741000 G</td> <td>-36.82</td> <td>-23.82</td> </tr> </tbody> </table> <p>Date: 12.AUG.2015 18:47:19</p>	Start [Hz]	Stop [Hz]	RBW [Hz]	Freq [Hz]	PwrAbs [dBm]	ΔLimit [dB]	30.000 M	820.000 M	1.00 M	534.810000 M	-44.55	-31.55	855.000 M	1.000 G	1.00 M	964.330008 M	-44.05	-31.05	1.000 G	3.000 G	1.00 M	2.994000 G	-40.50	-27.50	3.000 G	7.000 G	1.00 M	3.038000 G	-37.79	-24.79	7.000 G	9.000 G	1.00 M	8.741000 G	-36.82	-23.82	 <table border="1" data-bbox="893 1162 1356 1252"> <thead> <tr> <th>Start [Hz]</th> <th>Stop [Hz]</th> <th>RBW [Hz]</th> <th>Freq [Hz]</th> <th>PwrAbs [dBm]</th> <th>ΔLimit [dB]</th> </tr> </thead> <tbody> <tr> <td>30.000 M</td> <td>820.000 M</td> <td>1.00 M</td> <td>794.917500 M</td> <td>-44.82</td> <td>-31.82</td> </tr> <tr> <td>855.000 M</td> <td>1.000 G</td> <td>1.00 M</td> <td>925.520004 M</td> <td>-44.17</td> <td>-31.17</td> </tr> <tr> <td>1.000 G</td> <td>3.000 G</td> <td>1.00 M</td> <td>2.976000 G</td> <td>-42.34</td> <td>-29.34</td> </tr> <tr> <td>3.000 G</td> <td>7.000 G</td> <td>1.00 M</td> <td>5.115000 G</td> <td>-37.96</td> <td>-24.96</td> </tr> <tr> <td>7.000 G</td> <td>9.000 G</td> <td>1.00 M</td> <td>7.878500 G</td> <td>-36.52</td> <td>-23.52</td> </tr> </tbody> </table> <p>Date: 12.AUG.2015 18:33:21</p>	Start [Hz]	Stop [Hz]	RBW [Hz]	Freq [Hz]	PwrAbs [dBm]	ΔLimit [dB]	30.000 M	820.000 M	1.00 M	794.917500 M	-44.82	-31.82	855.000 M	1.000 G	1.00 M	925.520004 M	-44.17	-31.17	1.000 G	3.000 G	1.00 M	2.976000 G	-42.34	-29.34	3.000 G	7.000 G	1.00 M	5.115000 G	-37.96	-24.96	7.000 G	9.000 G	1.00 M	7.878500 G	-36.52	-23.52
Start [Hz]	Stop [Hz]	RBW [Hz]	Freq [Hz]	PwrAbs [dBm]	ΔLimit [dB]																																																																				
30.000 M	820.000 M	1.00 M	534.810000 M	-44.55	-31.55																																																																				
855.000 M	1.000 G	1.00 M	964.330008 M	-44.05	-31.05																																																																				
1.000 G	3.000 G	1.00 M	2.994000 G	-40.50	-27.50																																																																				
3.000 G	7.000 G	1.00 M	3.038000 G	-37.79	-24.79																																																																				
7.000 G	9.000 G	1.00 M	8.741000 G	-36.82	-23.82																																																																				
Start [Hz]	Stop [Hz]	RBW [Hz]	Freq [Hz]	PwrAbs [dBm]	ΔLimit [dB]																																																																				
30.000 M	820.000 M	1.00 M	794.917500 M	-44.82	-31.82																																																																				
855.000 M	1.000 G	1.00 M	925.520004 M	-44.17	-31.17																																																																				
1.000 G	3.000 G	1.00 M	2.976000 G	-42.34	-29.34																																																																				
3.000 G	7.000 G	1.00 M	5.115000 G	-37.96	-24.96																																																																				
7.000 G	9.000 G	1.00 M	7.878500 G	-36.52	-23.52																																																																				
Highest Channel	Highest Channel																																																																								
 <table border="1" data-bbox="239 1675 702 1765"> <thead> <tr> <th>Start [Hz]</th> <th>Stop [Hz]</th> <th>RBW [Hz]</th> <th>Freq [Hz]</th> <th>PwrAbs [dBm]</th> <th>ΔLimit [dB]</th> </tr> </thead> <tbody> <tr> <td>30.000 M</td> <td>820.000 M</td> <td>1.00 M</td> <td>808.545000 M</td> <td>-45.03</td> <td>-32.03</td> </tr> <tr> <td>855.000 M</td> <td>1.000 G</td> <td>1.00 M</td> <td>996.01310 M</td> <td>-44.25</td> <td>-31.25</td> </tr> <tr> <td>1.000 G</td> <td>3.000 G</td> <td>1.00 M</td> <td>2.979500 G</td> <td>-42.80</td> <td>-29.80</td> </tr> <tr> <td>3.000 G</td> <td>7.000 G</td> <td>1.00 M</td> <td>3.445000 G</td> <td>-37.40</td> <td>-24.40</td> </tr> <tr> <td>7.000 G</td> <td>9.000 G</td> <td>1.00 M</td> <td>8.212000 G</td> <td>-35.90</td> <td>-22.90</td> </tr> </tbody> </table> <p>Date: 12.AUG.2015 18:47:49</p>	Start [Hz]	Stop [Hz]	RBW [Hz]	Freq [Hz]	PwrAbs [dBm]	ΔLimit [dB]	30.000 M	820.000 M	1.00 M	808.545000 M	-45.03	-32.03	855.000 M	1.000 G	1.00 M	996.01310 M	-44.25	-31.25	1.000 G	3.000 G	1.00 M	2.979500 G	-42.80	-29.80	3.000 G	7.000 G	1.00 M	3.445000 G	-37.40	-24.40	7.000 G	9.000 G	1.00 M	8.212000 G	-35.90	-22.90	 <table border="1" data-bbox="893 1675 1356 1765"> <thead> <tr> <th>Start [Hz]</th> <th>Stop [Hz]</th> <th>RBW [Hz]</th> <th>Freq [Hz]</th> <th>PwrAbs [dBm]</th> <th>ΔLimit [dB]</th> </tr> </thead> <tbody> <tr> <td>30.000 M</td> <td>820.000 M</td> <td>1.00 M</td> <td>797.682500 M</td> <td>-44.45</td> <td>-31.45</td> </tr> <tr> <td>855.000 M</td> <td>1.000 G</td> <td>1.00 M</td> <td>893.461253 M</td> <td>-44.35</td> <td>-31.35</td> </tr> <tr> <td>1.000 G</td> <td>3.000 G</td> <td>1.00 M</td> <td>2.982000 G</td> <td>-42.03</td> <td>-29.03</td> </tr> <tr> <td>3.000 G</td> <td>7.000 G</td> <td>1.00 M</td> <td>3.493000 G</td> <td>-37.15</td> <td>-24.15</td> </tr> <tr> <td>7.000 G</td> <td>9.000 G</td> <td>1.00 M</td> <td>8.719000 G</td> <td>-36.41</td> <td>-23.41</td> </tr> </tbody> </table> <p>Date: 12.AUG.2015 18:33:51</p>	Start [Hz]	Stop [Hz]	RBW [Hz]	Freq [Hz]	PwrAbs [dBm]	ΔLimit [dB]	30.000 M	820.000 M	1.00 M	797.682500 M	-44.45	-31.45	855.000 M	1.000 G	1.00 M	893.461253 M	-44.35	-31.35	1.000 G	3.000 G	1.00 M	2.982000 G	-42.03	-29.03	3.000 G	7.000 G	1.00 M	3.493000 G	-37.15	-24.15	7.000 G	9.000 G	1.00 M	8.719000 G	-36.41	-23.41
Start [Hz]	Stop [Hz]	RBW [Hz]	Freq [Hz]	PwrAbs [dBm]	ΔLimit [dB]																																																																				
30.000 M	820.000 M	1.00 M	808.545000 M	-45.03	-32.03																																																																				
855.000 M	1.000 G	1.00 M	996.01310 M	-44.25	-31.25																																																																				
1.000 G	3.000 G	1.00 M	2.979500 G	-42.80	-29.80																																																																				
3.000 G	7.000 G	1.00 M	3.445000 G	-37.40	-24.40																																																																				
7.000 G	9.000 G	1.00 M	8.212000 G	-35.90	-22.90																																																																				
Start [Hz]	Stop [Hz]	RBW [Hz]	Freq [Hz]	PwrAbs [dBm]	ΔLimit [dB]																																																																				
30.000 M	820.000 M	1.00 M	797.682500 M	-44.45	-31.45																																																																				
855.000 M	1.000 G	1.00 M	893.461253 M	-44.35	-31.35																																																																				
1.000 G	3.000 G	1.00 M	2.982000 G	-42.03	-29.03																																																																				
3.000 G	7.000 G	1.00 M	3.493000 G	-37.15	-24.15																																																																				
7.000 G	9.000 G	1.00 M	8.719000 G	-36.41	-23.41																																																																				



GSM1900 (GSM)

Lowest Channel

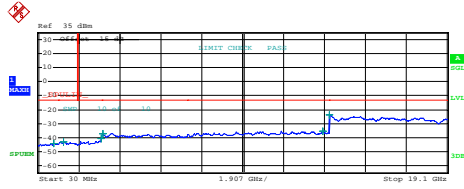

Start [Hz]	Stop [Hz]	RBW [Hz]	Freq [Hz]	PwrAbs [dBm]	ΔLimit [dB]
30.000 M	1.000 G	1.00 M	741.010500 M	-44.11	-31.11
1.000 G	1.845 G	1.00 M	1.228573 G	-43.17	-30.17
1.915 G	3.000 G	1.00 M	2.985352 G	-40.46	-27.46
3.000 G	7.000 G	1.00 M	3.039000 G	-37.29	-24.29
7.000 G	13.600 G	1.00 M	13.284850 G	-35.32	-22.32
13.600 G	19.100 G	1.00 M	13.607563 G	-24.03	-11.03

Date: 12.AUG.2015 19:10:05

GSM1900 (EDGE class 8)

Lowest Channel

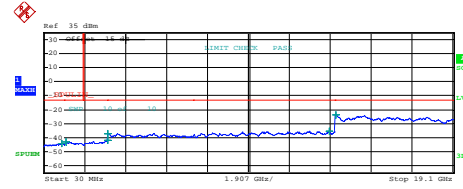

Start [Hz]	Stop [Hz]	RBW [Hz]	Freq [Hz]	PwrAbs [dBm]	ΔLimit [dB]
30.000 M	1.000 G	1.00 M	866.080000 M	-44.19	-31.19
1.000 G	1.845 G	1.00 M	1.077740 G	-43.34	-30.34
1.915 G	3.000 G	1.00 M	2.986438 G	-41.72	-28.72
3.000 G	7.000 G	1.00 M	3.032000 G	-37.07	-24.07
7.000 G	13.600 G	1.00 M	13.337650 G	-35.68	-22.68
13.600 G	19.100 G	1.00 M	13.643313 G	-23.68	-10.68

Date: 12.AUG.2015 18:17:47

Middle Channel

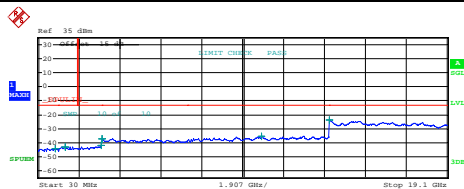

Start [Hz]	Stop [Hz]	RBW [Hz]	Freq [Hz]	PwrAbs [dBm]	ΔLimit [dB]
30.000 M	1.000 G	1.00 M	819.822500 M	-44.44	-31.44
1.000 G	1.845 G	1.00 M	3.000386 G	-42.82	-29.82
1.915 G	3.000 G	1.00 M	2.962296 G	-41.87	-28.87
3.000 G	7.000 G	1.00 M	3.033000 G	-37.10	-24.10
7.000 G	13.600 G	1.00 M	10.489326 G	-35.44	-22.44
13.600 G	19.100 G	1.00 M	13.608938 G	-23.73	-10.73

Date: 12.AUG.2015 19:10:34

Middle Channel

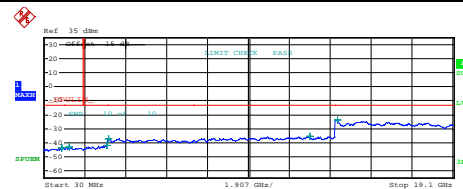

Start [Hz]	Stop [Hz]	RBW [Hz]	Freq [Hz]	PwrAbs [dBm]	ΔLimit [dB]
30.000 M	1.000 G	1.00 M	854.985000 M	-43.82	-30.82
1.000 G	1.845 G	1.00 M	3.022455 G	-43.20	-30.20
1.915 G	3.000 G	1.00 M	2.959855 G	-42.16	-29.16
3.000 G	7.000 G	1.00 M	3.035000 G	-37.02	-24.02
7.000 G	13.600 G	1.00 M	12.439425 G	-35.70	-22.70
13.600 G	19.100 G	1.00 M	13.703813 G	-23.97	-10.97

Date: 12.AUG.2015 18:18:17

Highest Channel

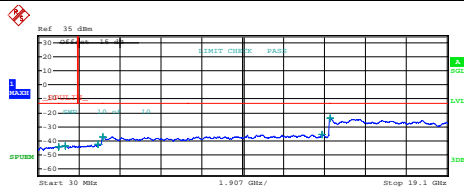

Start [Hz]	Stop [Hz]	RBW [Hz]	Freq [Hz]	PwrAbs [dBm]	ΔLimit [dB]
30.000 M	1.000 G	1.00 M	988.350500 M	-44.45	-31.45
1.000 G	1.845 G	1.00 M	1.273780 G	-43.37	-30.37
1.915 G	3.000 G	1.00 M	2.820432 G	-42.23	-29.23
3.000 G	7.000 G	1.00 M	3.032000 G	-37.04	-24.04
7.000 G	13.600 G	1.00 M	13.263400 G	-35.33	-22.33
13.600 G	19.100 G	1.00 M	13.640563 G	-23.98	-10.98

Date: 12.AUG.2015 19:11:04

Highest Channel

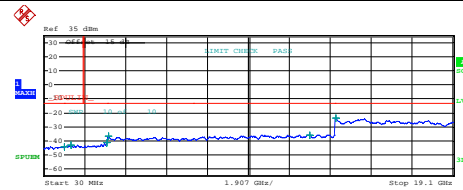

Start [Hz]	Stop [Hz]	RBW [Hz]	Freq [Hz]	PwrAbs [dBm]	ΔLimit [dB]
30.000 M	1.000 G	1.00 M	974.052500 M	-44.23	-31.23
1.000 G	1.845 G	1.00 M	1.294694 G	-42.91	-29.91
1.915 G	3.000 G	1.00 M	2.983826 G	-41.30	-28.30
3.000 G	7.000 G	1.00 M	3.042000 G	-36.74	-23.74
7.000 G	13.600 G	1.00 M	12.431800 G	-35.89	-22.89
13.600 G	19.100 G	1.00 M	13.661188 G	-23.80	-10.80

Date: 12.AUG.2015 18:18:47



Frequency Stability

Test Conditions	Middle Channel	GSM850 (GSM)	GSM850 (EDGE class 8)	Limit 2.5ppm
Temperature (°C)	Voltage (Volt)	Deviation (ppm)		Result
50	Normal Voltage	0.0060	0.0072	PASS
40	Normal Voltage	0.0048	0.0048	
30	Normal Voltage	0.0024	0.0024	
20(Ref.)	Normal Voltage	0.0000	0.0000	
10	Normal Voltage	0.0012	0.0024	
0	Normal Voltage	0.0024	0.0036	
-10	Normal Voltage	0.0036	0.0048	
-20	Normal Voltage	0.0060	0.0072	
-30	Normal Voltage	0.0084	0.0096	
20	Maximum Voltage	0.0012	0.0012	
20	Normal Voltage	0.0000	0.0000	
20	Battery End Point	0.0012	0.0012	

Test Conditions	Middle Channel	GSM1900 (GSM)	GSM1900 (EDGE class 8)	Limit Note 2.
Temperature (°C)	Voltage (Volt)	Deviation (ppm)		Result
50	Normal Voltage	0.0037	0.0016	PASS
40	Normal Voltage	0.0027	0.0011	
30	Normal Voltage	0.0011	0.0005	
20(Ref.)	Normal Voltage	0.0000	0.0000	
10	Normal Voltage	0.0011	0.0005	
0	Normal Voltage	0.0016	0.0128	
-10	Normal Voltage	0.0027	0.0133	
-20	Normal Voltage	0.0032	0.0138	
-30	Normal Voltage	0.0043	0.0144	
20	Maximum Voltage	0.0005	0.0011	
20	Normal Voltage	0.0000	0.0000	
20	Battery End Point	0.0005	0.0005	

Note:

1. Normal Voltage = 3.7V. ; Battery End Point (BEP) = 3.5 V. ; Maximum Voltage =4.3 V
2. The frequency fundamental emissions stay within the authorized frequency block based on the frequency deviation measured is small.



A2. WCDMA

Peak-to-Average Ratio

Mode	WCDMA Band V	WCDMA Band II	Limit: 13dB
Mod.	RMC 12.2Kbps	RMC 12.2Kbps	Result
Lowest CH	2.92	3.08	PASS
Middle CH	3.00	3.12	
Highest CH	2.80	3.16	

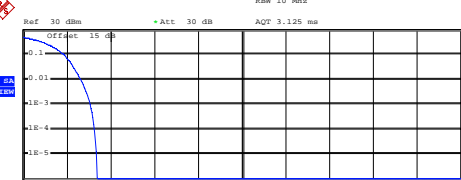
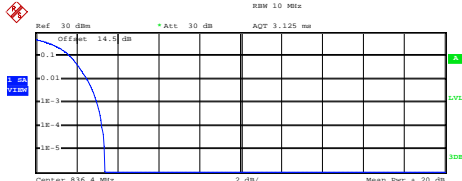
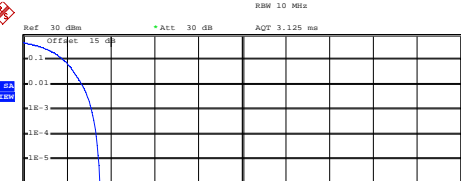
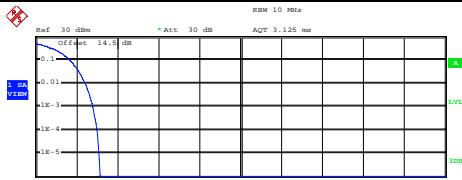
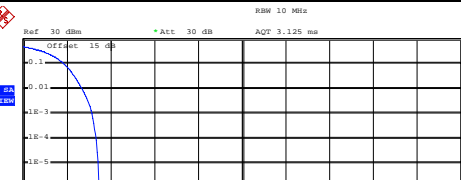

WCDMA Band V (RMC 12.2Kbps)	WCDMA Band II (RMC 12.2Kbps)																
<p align="center">Lowest Channel</p>  <p>Center 826.4 MHz 2 dB/ Mean Pwr + 20 dB</p> <p>Complementary Cumulative Distribution Function (100000 samples)</p> <p>Trace 1</p> <p>Mean 22.95 dBm Peak 26.23 dBm Crest 3.29 dB</p> <table border="0"> <tr><td>10 %</td><td>1.68 dB</td></tr> <tr><td>1 %</td><td>2.44 dB</td></tr> <tr><td>.1 %</td><td>2.92 dB</td></tr> <tr><td>.01 %</td><td>3.16 dB</td></tr> </table> <p>Date: 12.AUG.2015 20:54:43</p>	10 %	1.68 dB	1 %	2.44 dB	.1 %	2.92 dB	.01 %	3.16 dB	<p align="center">Lowest Channel</p>  <p>Center 1.8524 GHz 2 dB/ Mean Pwr + 20 dB</p> <p>Complementary Cumulative Distribution Function (100000 samples)</p> <p>Trace 1</p> <p>Mean 22.57 dBm Peak 25.95 dBm Crest 3.38 dB</p> <table border="0"> <tr><td>10 %</td><td>1.88 dB</td></tr> <tr><td>1 %</td><td>2.64 dB</td></tr> <tr><td>.1 %</td><td>3.08 dB</td></tr> <tr><td>.01 %</td><td>3.28 dB</td></tr> </table> <p>Date: 12.AUG.2015 21:14:27</p>	10 %	1.88 dB	1 %	2.64 dB	.1 %	3.08 dB	.01 %	3.28 dB
10 %	1.68 dB																
1 %	2.44 dB																
.1 %	2.92 dB																
.01 %	3.16 dB																
10 %	1.88 dB																
1 %	2.64 dB																
.1 %	3.08 dB																
.01 %	3.28 dB																
<p align="center">Middle Channel</p>  <p>Center 836.4 MHz 2 dB/ Mean Pwr + 20 dB</p> <p>Complementary Cumulative Distribution Function (100000 samples)</p> <p>Trace 1</p> <p>Mean 22.72 dBm Peak 26.09 dBm Crest 3.37 dB</p> <table border="0"> <tr><td>10 %</td><td>1.68 dB</td></tr> <tr><td>1 %</td><td>2.52 dB</td></tr> <tr><td>.1 %</td><td>3.00 dB</td></tr> <tr><td>.01 %</td><td>3.24 dB</td></tr> </table> <p>Date: 12.AUG.2015 20:54:59</p>	10 %	1.68 dB	1 %	2.52 dB	.1 %	3.00 dB	.01 %	3.24 dB	<p align="center">Middle Channel</p>  <p>Center 1.88 GHz 2 dB/ Mean Pwr + 20 dB</p> <p>Complementary Cumulative Distribution Function (100000 samples)</p> <p>Trace 1</p> <p>Mean 22.23 dBm Peak 25.74 dBm Crest 3.51 dB</p> <table border="0"> <tr><td>10 %</td><td>1.84 dB</td></tr> <tr><td>1 %</td><td>2.72 dB</td></tr> <tr><td>.1 %</td><td>3.12 dB</td></tr> <tr><td>.01 %</td><td>3.36 dB</td></tr> </table> <p>Date: 12.AUG.2015 21:14:52</p>	10 %	1.84 dB	1 %	2.72 dB	.1 %	3.12 dB	.01 %	3.36 dB
10 %	1.68 dB																
1 %	2.52 dB																
.1 %	3.00 dB																
.01 %	3.24 dB																
10 %	1.84 dB																
1 %	2.72 dB																
.1 %	3.12 dB																
.01 %	3.36 dB																
<p align="center">Highest Channel</p>  <p>Center 846.6 MHz 2 dB/ Mean Pwr + 20 dB</p> <p>Complementary Cumulative Distribution Function (100000 samples)</p> <p>Trace 1</p> <p>Mean 22.87 dBm Peak 26.02 dBm Crest 3.16 dB</p> <table border="0"> <tr><td>10 %</td><td>1.68 dB</td></tr> <tr><td>1 %</td><td>2.44 dB</td></tr> <tr><td>.1 %</td><td>2.80 dB</td></tr> <tr><td>.01 %</td><td>3.00 dB</td></tr> </table> <p>Date: 12.AUG.2015 20:55:10</p>	10 %	1.68 dB	1 %	2.44 dB	.1 %	2.80 dB	.01 %	3.00 dB	<p align="center">Highest Channel</p>  <p>Center 1.9076 GHz 2 dB/ Mean Pwr + 20 dB</p> <p>Complementary Cumulative Distribution Function (100000 samples)</p> <p>Trace 1</p> <p>Mean 22.49 dBm Peak 25.95 dBm Crest 3.46 dB</p> <table border="0"> <tr><td>10 %</td><td>1.88 dB</td></tr> <tr><td>1 %</td><td>2.72 dB</td></tr> <tr><td>.1 %</td><td>3.16 dB</td></tr> <tr><td>.01 %</td><td>3.36 dB</td></tr> </table> <p>Date: 12.AUG.2015 21:15:16</p>	10 %	1.88 dB	1 %	2.72 dB	.1 %	3.16 dB	.01 %	3.36 dB
10 %	1.68 dB																
1 %	2.44 dB																
.1 %	2.80 dB																
.01 %	3.00 dB																
10 %	1.88 dB																
1 %	2.72 dB																
.1 %	3.16 dB																
.01 %	3.36 dB																



26dB Bandwidth

Mode	WCDMA Band V	WCDMA Band II
Mod.	RMC 12.2Kbps	RMC 12.2Kbps
Lowest CH	4.85	4.84
Middle CH	4.87	4.84
Highest CH	4.85	4.82



WCDMA Band V (RMC 12.2Kbps)

Lowest Channel

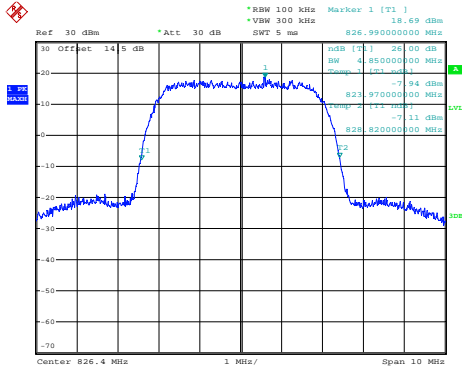

Date: 12.AUG.2015 20:50:32

WCDMA Band II (RMC 12.2Kbps)

Lowest Channel

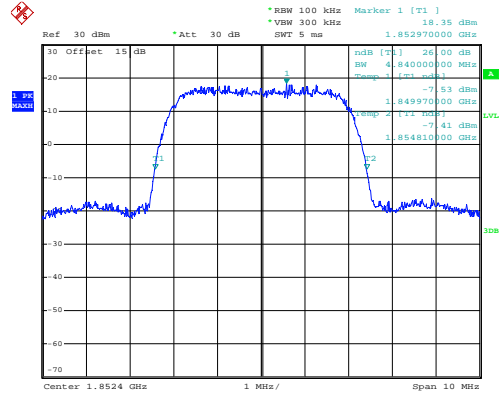

Date: 12.AUG.2015 21:10:52

Middle Channel

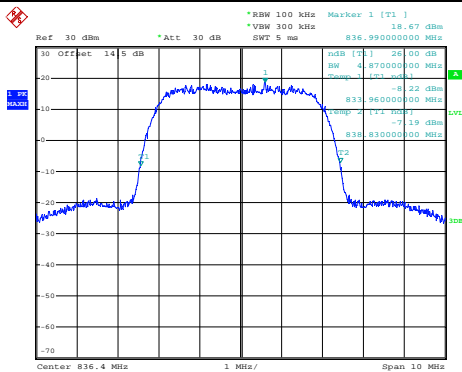

Date: 12.AUG.2015 20:51:00

Middle Channel

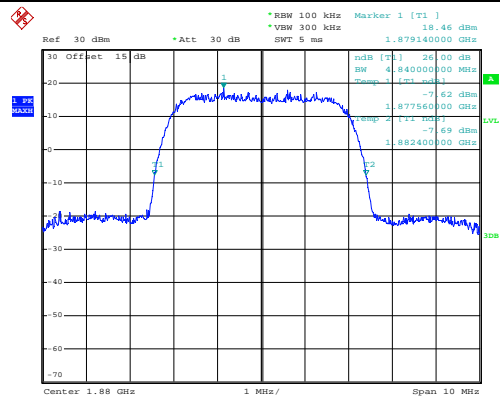

Date: 12.AUG.2015 21:11:20

Highest Channel

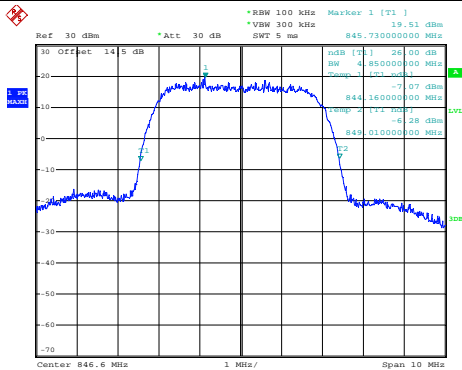

Date: 12.AUG.2015 20:51:28

Highest Channel

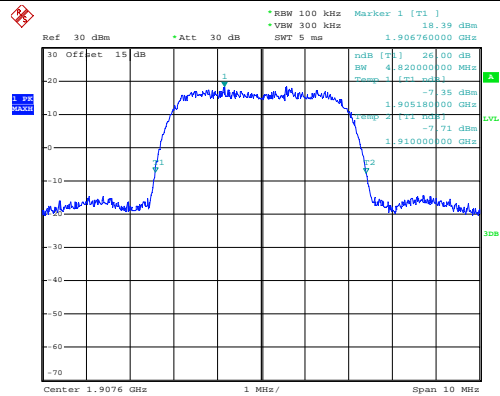

Date: 12.AUG.2015 21:11:48



Occupied Bandwidth

Mode	WCDMA Band V	WCDMA Band II
Mod.	RMC 12.2Kbps	RMC 12.2Kbps
Lowest CH	4.22	4.21
Middle CH	4.21	4.22
Highest CH	4.20	4.22



WCDMA Band V (RMC 12.2Kbps)

Lowest Channel

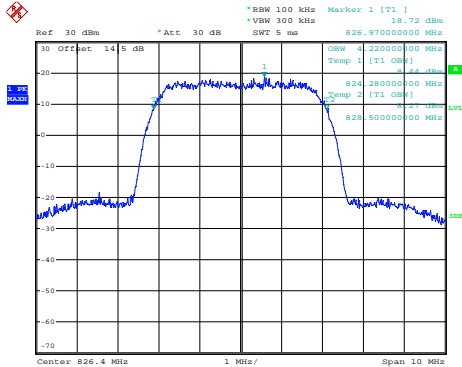

Date: 12.AUG.2015 20:52:56

WCDMA Band II (RMC 12.2Kbps)

Lowest Channel

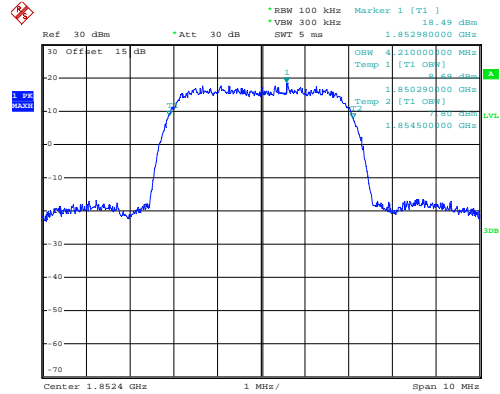

Date: 12.AUG.2015 21:12:51

Middle Channel

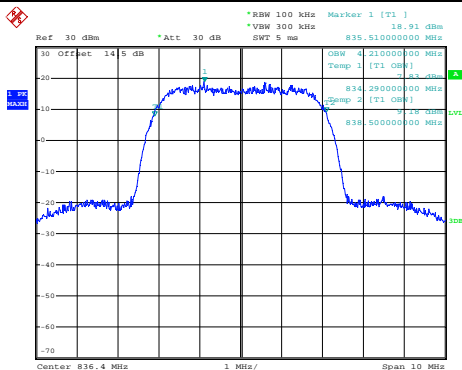

Date: 12.AUG.2015 20:53:24

Middle Channel

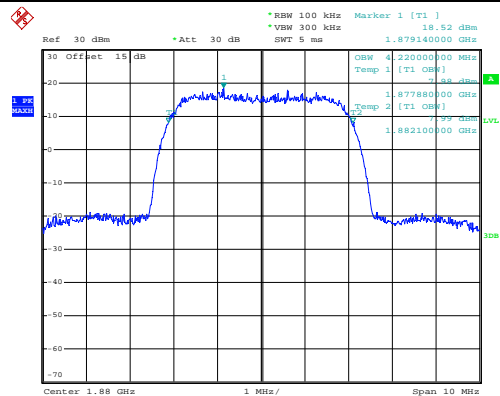

Date: 12.AUG.2015 21:13:19

Highest Channel

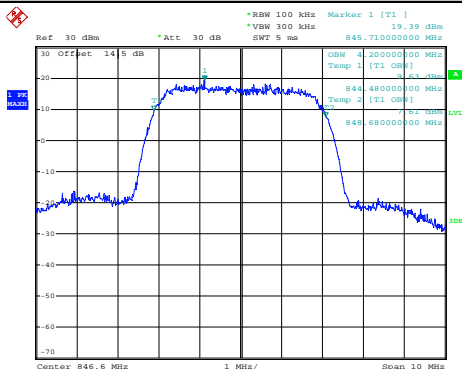

Date: 12.AUG.2015 20:53:52

Highest Channel

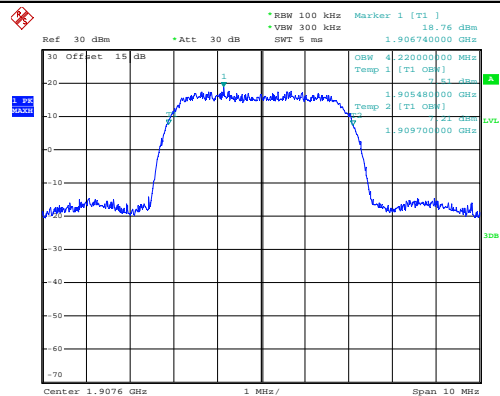

Date: 12.AUG.2015 21:13:47



Conducted Band Edge

WCDMA Band V (RMC 12.2Kbps)

Lowest Band Edge

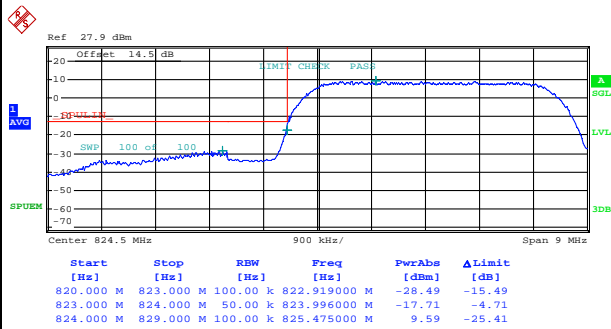

Date: 12.AUG.2015 21:35:12

Highest Band Edge

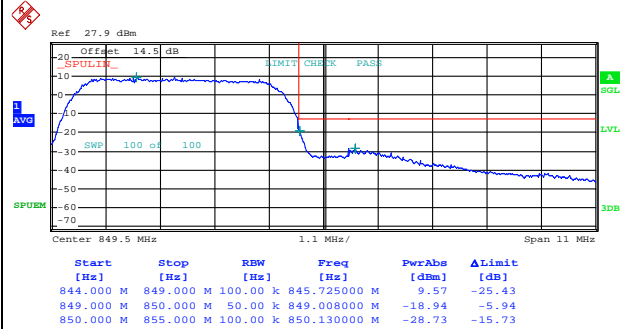

Date: 12.AUG.2015 21:40:57



WCDMA Band II (RMC 12.2Kbps)

Lowest Band Edge

Highest Band Edge

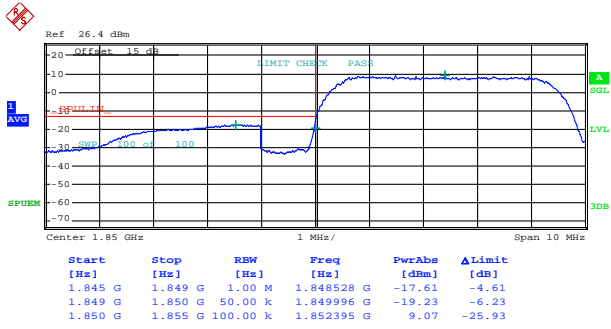

Date: 12.AUG.2015 21:26:12

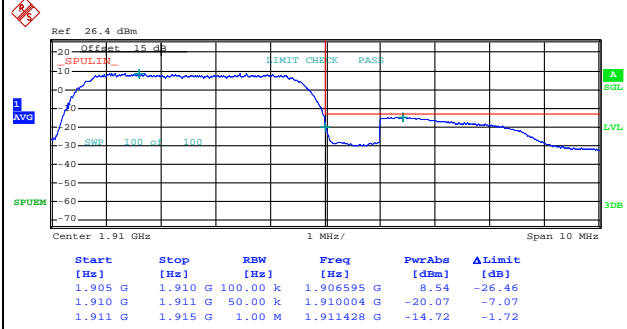

Date: 12.AUG.2015 21:30:24



Conducted Spurious Emission

WCDMA Band V (RMC 12.2Kbps)	WCDMA Band II (RMC 12.2Kbps)																																																																																										
<p>Lowest Channel</p> <table border="1"> <thead> <tr> <th>Start</th> <th>Stop</th> <th>RBW</th> <th>Freq</th> <th>PowerAbs</th> <th>ΔLimit</th> </tr> <tr> <th>[Hz]</th> <th>[Hz]</th> <th>[Hz]</th> <th>[Hz]</th> <th>[dBm]</th> <th>[dB]</th> </tr> </thead> <tbody> <tr> <td>30.000 M</td> <td>820.000 M</td> <td>1.00 M</td> <td>771.413500 M</td> <td>-45.35</td> <td>-32.15</td> </tr> <tr> <td>855.000 M</td> <td>1.000 G</td> <td>1.00 M</td> <td>863.917501 M</td> <td>-44.69</td> <td>-31.69</td> </tr> <tr> <td>1.000 G</td> <td>3.000 G</td> <td>1.00 M</td> <td>2.988500 G</td> <td>-42.82</td> <td>-29.82</td> </tr> <tr> <td>3.000 G</td> <td>7.000 G</td> <td>1.00 M</td> <td>3.472000 G</td> <td>-37.65</td> <td>-24.65</td> </tr> <tr> <td>7.000 G</td> <td>9.000 G</td> <td>1.00 M</td> <td>7.957000 G</td> <td>-36.44</td> <td>-23.44</td> </tr> </tbody> </table> <p>Date: 12.AUG.2015 20:56:12</p>	Start	Stop	RBW	Freq	PowerAbs	ΔLimit	[Hz]	[Hz]	[Hz]	[Hz]	[dBm]	[dB]	30.000 M	820.000 M	1.00 M	771.413500 M	-45.35	-32.15	855.000 M	1.000 G	1.00 M	863.917501 M	-44.69	-31.69	1.000 G	3.000 G	1.00 M	2.988500 G	-42.82	-29.82	3.000 G	7.000 G	1.00 M	3.472000 G	-37.65	-24.65	7.000 G	9.000 G	1.00 M	7.957000 G	-36.44	-23.44	<p>Lowest Channel</p> <table border="1"> <thead> <tr> <th>Start</th> <th>Stop</th> <th>RBW</th> <th>Freq</th> <th>PowerAbs</th> <th>ΔLimit</th> </tr> <tr> <th>[Hz]</th> <th>[Hz]</th> <th>[Hz]</th> <th>[Hz]</th> <th>[dBm]</th> <th>[dB]</th> </tr> </thead> <tbody> <tr> <td>30.000 M</td> <td>1.000 G</td> <td>1.00 M</td> <td>865.170000 M</td> <td>-44.41</td> <td>-31.41</td> </tr> <tr> <td>1.000 G</td> <td>1.845 G</td> <td>1.00 M</td> <td>1.276949 G</td> <td>-43.37</td> <td>-30.37</td> </tr> <tr> <td>1.915 G</td> <td>3.000 G</td> <td>1.00 M</td> <td>2.988500 G</td> <td>-42.66</td> <td>-29.66</td> </tr> <tr> <td>3.000 G</td> <td>7.000 G</td> <td>1.00 M</td> <td>3.054000 G</td> <td>-37.12</td> <td>-24.12</td> </tr> <tr> <td>7.000 G</td> <td>13.600 G</td> <td>1.00 M</td> <td>13.319500 G</td> <td>-35.45</td> <td>-22.45</td> </tr> <tr> <td>13.600 G</td> <td>19.100 G</td> <td>1.00 M</td> <td>13.662937 G</td> <td>-24.56</td> <td>-11.56</td> </tr> </tbody> </table> <p>Date: 12.AUG.2015 21:16:26</p>	Start	Stop	RBW	Freq	PowerAbs	ΔLimit	[Hz]	[Hz]	[Hz]	[Hz]	[dBm]	[dB]	30.000 M	1.000 G	1.00 M	865.170000 M	-44.41	-31.41	1.000 G	1.845 G	1.00 M	1.276949 G	-43.37	-30.37	1.915 G	3.000 G	1.00 M	2.988500 G	-42.66	-29.66	3.000 G	7.000 G	1.00 M	3.054000 G	-37.12	-24.12	7.000 G	13.600 G	1.00 M	13.319500 G	-35.45	-22.45	13.600 G	19.100 G	1.00 M	13.662937 G	-24.56	-11.56
Start	Stop	RBW	Freq	PowerAbs	ΔLimit																																																																																						
[Hz]	[Hz]	[Hz]	[Hz]	[dBm]	[dB]																																																																																						
30.000 M	820.000 M	1.00 M	771.413500 M	-45.35	-32.15																																																																																						
855.000 M	1.000 G	1.00 M	863.917501 M	-44.69	-31.69																																																																																						
1.000 G	3.000 G	1.00 M	2.988500 G	-42.82	-29.82																																																																																						
3.000 G	7.000 G	1.00 M	3.472000 G	-37.65	-24.65																																																																																						
7.000 G	9.000 G	1.00 M	7.957000 G	-36.44	-23.44																																																																																						
Start	Stop	RBW	Freq	PowerAbs	ΔLimit																																																																																						
[Hz]	[Hz]	[Hz]	[Hz]	[dBm]	[dB]																																																																																						
30.000 M	1.000 G	1.00 M	865.170000 M	-44.41	-31.41																																																																																						
1.000 G	1.845 G	1.00 M	1.276949 G	-43.37	-30.37																																																																																						
1.915 G	3.000 G	1.00 M	2.988500 G	-42.66	-29.66																																																																																						
3.000 G	7.000 G	1.00 M	3.054000 G	-37.12	-24.12																																																																																						
7.000 G	13.600 G	1.00 M	13.319500 G	-35.45	-22.45																																																																																						
13.600 G	19.100 G	1.00 M	13.662937 G	-24.56	-11.56																																																																																						
<p>Middle Channel</p> <table border="1"> <thead> <tr> <th>Start</th> <th>Stop</th> <th>RBW</th> <th>Freq</th> <th>PowerAbs</th> <th>ΔLimit</th> </tr> <tr> <th>[Hz]</th> <th>[Hz]</th> <th>[Hz]</th> <th>[Hz]</th> <th>[dBm]</th> <th>[dB]</th> </tr> </thead> <tbody> <tr> <td>30.000 M</td> <td>820.000 M</td> <td>1.00 M</td> <td>615.390000 M</td> <td>-45.03</td> <td>-32.03</td> </tr> <tr> <td>855.000 M</td> <td>1.000 G</td> <td>1.00 M</td> <td>850.897502 M</td> <td>-44.93</td> <td>-31.93</td> </tr> <tr> <td>1.000 G</td> <td>3.000 G</td> <td>1.00 M</td> <td>2.984500 G</td> <td>-43.13</td> <td>-30.13</td> </tr> <tr> <td>3.000 G</td> <td>7.000 G</td> <td>1.00 M</td> <td>3.032000 G</td> <td>-37.79</td> <td>-24.79</td> </tr> <tr> <td>7.000 G</td> <td>9.000 G</td> <td>1.00 M</td> <td>6.747000 G</td> <td>-36.96</td> <td>-23.96</td> </tr> </tbody> </table> <p>Date: 12.AUG.2015 20:56:42</p>	Start	Stop	RBW	Freq	PowerAbs	ΔLimit	[Hz]	[Hz]	[Hz]	[Hz]	[dBm]	[dB]	30.000 M	820.000 M	1.00 M	615.390000 M	-45.03	-32.03	855.000 M	1.000 G	1.00 M	850.897502 M	-44.93	-31.93	1.000 G	3.000 G	1.00 M	2.984500 G	-43.13	-30.13	3.000 G	7.000 G	1.00 M	3.032000 G	-37.79	-24.79	7.000 G	9.000 G	1.00 M	6.747000 G	-36.96	-23.96	<p>Middle Channel</p> <table border="1"> <thead> <tr> <th>Start</th> <th>Stop</th> <th>RBW</th> <th>Freq</th> <th>PowerAbs</th> <th>ΔLimit</th> </tr> <tr> <th>[Hz]</th> <th>[Hz]</th> <th>[Hz]</th> <th>[Hz]</th> <th>[dBm]</th> <th>[dB]</th> </tr> </thead> <tbody> <tr> <td>30.000 M</td> <td>1.000 G</td> <td>1.00 M</td> <td>959.017500 M</td> <td>-44.86</td> <td>-31.86</td> </tr> <tr> <td>1.000 G</td> <td>1.845 G</td> <td>1.00 M</td> <td>1.338354 G</td> <td>-44.23</td> <td>-31.23</td> </tr> <tr> <td>1.915 G</td> <td>3.000 G</td> <td>1.00 M</td> <td>2.991049 G</td> <td>-42.32</td> <td>-29.32</td> </tr> <tr> <td>3.000 G</td> <td>7.000 G</td> <td>1.00 M</td> <td>3.038000 G</td> <td>-37.44</td> <td>-24.44</td> </tr> <tr> <td>7.000 G</td> <td>13.600 G</td> <td>1.00 M</td> <td>12.834250 G</td> <td>-35.26</td> <td>-22.26</td> </tr> <tr> <td>13.600 G</td> <td>19.100 G</td> <td>1.00 M</td> <td>13.677000 G</td> <td>-24.07</td> <td>-11.07</td> </tr> </tbody> </table> <p>Date: 12.AUG.2015 21:16:55</p>	Start	Stop	RBW	Freq	PowerAbs	ΔLimit	[Hz]	[Hz]	[Hz]	[Hz]	[dBm]	[dB]	30.000 M	1.000 G	1.00 M	959.017500 M	-44.86	-31.86	1.000 G	1.845 G	1.00 M	1.338354 G	-44.23	-31.23	1.915 G	3.000 G	1.00 M	2.991049 G	-42.32	-29.32	3.000 G	7.000 G	1.00 M	3.038000 G	-37.44	-24.44	7.000 G	13.600 G	1.00 M	12.834250 G	-35.26	-22.26	13.600 G	19.100 G	1.00 M	13.677000 G	-24.07	-11.07
Start	Stop	RBW	Freq	PowerAbs	ΔLimit																																																																																						
[Hz]	[Hz]	[Hz]	[Hz]	[dBm]	[dB]																																																																																						
30.000 M	820.000 M	1.00 M	615.390000 M	-45.03	-32.03																																																																																						
855.000 M	1.000 G	1.00 M	850.897502 M	-44.93	-31.93																																																																																						
1.000 G	3.000 G	1.00 M	2.984500 G	-43.13	-30.13																																																																																						
3.000 G	7.000 G	1.00 M	3.032000 G	-37.79	-24.79																																																																																						
7.000 G	9.000 G	1.00 M	6.747000 G	-36.96	-23.96																																																																																						
Start	Stop	RBW	Freq	PowerAbs	ΔLimit																																																																																						
[Hz]	[Hz]	[Hz]	[Hz]	[dBm]	[dB]																																																																																						
30.000 M	1.000 G	1.00 M	959.017500 M	-44.86	-31.86																																																																																						
1.000 G	1.845 G	1.00 M	1.338354 G	-44.23	-31.23																																																																																						
1.915 G	3.000 G	1.00 M	2.991049 G	-42.32	-29.32																																																																																						
3.000 G	7.000 G	1.00 M	3.038000 G	-37.44	-24.44																																																																																						
7.000 G	13.600 G	1.00 M	12.834250 G	-35.26	-22.26																																																																																						
13.600 G	19.100 G	1.00 M	13.677000 G	-24.07	-11.07																																																																																						
<p>Highest Channel</p> <table border="1"> <thead> <tr> <th>Start</th> <th>Stop</th> <th>RBW</th> <th>Freq</th> <th>PowerAbs</th> <th>ΔLimit</th> </tr> <tr> <th>[Hz]</th> <th>[Hz]</th> <th>[Hz]</th> <th>[Hz]</th> <th>[dBm]</th> <th>[dB]</th> </tr> </thead> <tbody> <tr> <td>30.000 M</td> <td>820.000 M</td> <td>1.00 M</td> <td>793.930000 M</td> <td>-45.30</td> <td>-32.30</td> </tr> <tr> <td>855.000 M</td> <td>1.000 G</td> <td>1.00 M</td> <td>889.220002 M</td> <td>-45.00</td> <td>-32.00</td> </tr> <tr> <td>1.000 G</td> <td>3.000 G</td> <td>1.00 M</td> <td>2.986000 G</td> <td>-42.80</td> <td>-29.80</td> </tr> <tr> <td>3.000 G</td> <td>7.000 G</td> <td>1.00 M</td> <td>3.443000 G</td> <td>-37.79</td> <td>-24.79</td> </tr> <tr> <td>7.000 G</td> <td>9.000 G</td> <td>1.00 M</td> <td>6.697500 G</td> <td>-36.62</td> <td>-23.62</td> </tr> </tbody> </table> <p>Date: 12.AUG.2015 20:57:11</p>	Start	Stop	RBW	Freq	PowerAbs	ΔLimit	[Hz]	[Hz]	[Hz]	[Hz]	[dBm]	[dB]	30.000 M	820.000 M	1.00 M	793.930000 M	-45.30	-32.30	855.000 M	1.000 G	1.00 M	889.220002 M	-45.00	-32.00	1.000 G	3.000 G	1.00 M	2.986000 G	-42.80	-29.80	3.000 G	7.000 G	1.00 M	3.443000 G	-37.79	-24.79	7.000 G	9.000 G	1.00 M	6.697500 G	-36.62	-23.62	<p>Highest Channel</p> <table border="1"> <thead> <tr> <th>Start</th> <th>Stop</th> <th>RBW</th> <th>Freq</th> <th>PowerAbs</th> <th>ΔLimit</th> </tr> <tr> <th>[Hz]</th> <th>[Hz]</th> <th>[Hz]</th> <th>[Hz]</th> <th>[dBm]</th> <th>[dB]</th> </tr> </thead> <tbody> <tr> <td>30.000 M</td> <td>1.000 G</td> <td>1.00 M</td> <td>821.520000 M</td> <td>-44.45</td> <td>-31.45</td> </tr> <tr> <td>1.000 G</td> <td>1.845 G</td> <td>1.00 M</td> <td>1.274488 G</td> <td>-44.01</td> <td>-31.01</td> </tr> <tr> <td>1.915 G</td> <td>3.000 G</td> <td>1.00 M</td> <td>2.731661 G</td> <td>-41.99</td> <td>-28.99</td> </tr> <tr> <td>3.000 G</td> <td>7.000 G</td> <td>1.00 M</td> <td>3.048000 G</td> <td>-37.00</td> <td>-24.00</td> </tr> <tr> <td>7.000 G</td> <td>13.600 G</td> <td>1.00 M</td> <td>12.423725 G</td> <td>-35.70</td> <td>-22.70</td> </tr> <tr> <td>13.600 G</td> <td>19.100 G</td> <td>1.00 M</td> <td>13.602750 G</td> <td>-23.39</td> <td>-10.39</td> </tr> </tbody> </table> <p>Date: 12.AUG.2015 21:17:25</p>	Start	Stop	RBW	Freq	PowerAbs	ΔLimit	[Hz]	[Hz]	[Hz]	[Hz]	[dBm]	[dB]	30.000 M	1.000 G	1.00 M	821.520000 M	-44.45	-31.45	1.000 G	1.845 G	1.00 M	1.274488 G	-44.01	-31.01	1.915 G	3.000 G	1.00 M	2.731661 G	-41.99	-28.99	3.000 G	7.000 G	1.00 M	3.048000 G	-37.00	-24.00	7.000 G	13.600 G	1.00 M	12.423725 G	-35.70	-22.70	13.600 G	19.100 G	1.00 M	13.602750 G	-23.39	-10.39
Start	Stop	RBW	Freq	PowerAbs	ΔLimit																																																																																						
[Hz]	[Hz]	[Hz]	[Hz]	[dBm]	[dB]																																																																																						
30.000 M	820.000 M	1.00 M	793.930000 M	-45.30	-32.30																																																																																						
855.000 M	1.000 G	1.00 M	889.220002 M	-45.00	-32.00																																																																																						
1.000 G	3.000 G	1.00 M	2.986000 G	-42.80	-29.80																																																																																						
3.000 G	7.000 G	1.00 M	3.443000 G	-37.79	-24.79																																																																																						
7.000 G	9.000 G	1.00 M	6.697500 G	-36.62	-23.62																																																																																						
Start	Stop	RBW	Freq	PowerAbs	ΔLimit																																																																																						
[Hz]	[Hz]	[Hz]	[Hz]	[dBm]	[dB]																																																																																						
30.000 M	1.000 G	1.00 M	821.520000 M	-44.45	-31.45																																																																																						
1.000 G	1.845 G	1.00 M	1.274488 G	-44.01	-31.01																																																																																						
1.915 G	3.000 G	1.00 M	2.731661 G	-41.99	-28.99																																																																																						
3.000 G	7.000 G	1.00 M	3.048000 G	-37.00	-24.00																																																																																						
7.000 G	13.600 G	1.00 M	12.423725 G	-35.70	-22.70																																																																																						
13.600 G	19.100 G	1.00 M	13.602750 G	-23.39	-10.39																																																																																						



Frequency Stability

Test Conditions	Middle Channel	WCDMA Band V (RMC 12.2Kbps)	Limit 2.5ppm
Temperature (°C)	Voltage (Volt)	Deviation (ppm)	Result
50	Normal Voltage	0.0155	PASS
40	Normal Voltage	0.0143	
30	Normal Voltage	0.0132	
20(Ref.)	Normal Voltage	0.0000	
10	Normal Voltage	0.0012	
0	Normal Voltage	0.0024	
-10	Normal Voltage	0.0036	
-20	Normal Voltage	0.0048	
-30	Normal Voltage	0.0060	
20	Maximum Voltage	0.0012	
20	Normal Voltage	0.0000	
20	Battery End Point	0.0024	

Test Conditions	Middle Channel	WCDMA Band II (RMC 12.2Kbps)	Limit Note 2.
Temperature (°C)	Voltage (Volt)	Deviation (ppm)	Result
50	Normal Voltage	0.0016	PASS
40	Normal Voltage	0.0011	
30	Normal Voltage	0.0005	
20(Ref.)	Normal Voltage	0.0000	
10	Normal Voltage	0.0117	
0	Normal Voltage	0.0122	
-10	Normal Voltage	0.0122	
-20	Normal Voltage	0.0128	
-30	Normal Voltage	0.0133	
20	Maximum Voltage	0.0005	
20	Normal Voltage	0.0000	
20	Battery End Point	0.0005	

Note:

1. Normal Voltage = 3.7V. ; Battery End Point (BEP) = 3.5 V. ; Maximum Voltage =4.3V
2. The frequency fundamental emissions stay within the authorized frequency block based on the frequency deviation measured is small.



Appendix B. Test Results of Radiated Test

ERP/EIRP

Channel	Mode	Horizontal		Vertical	
		ERP(dBm)	ERP(W)	ERP(dBm)	ERP(W)
Lowest	GSM850 GSM	28.85	0.7674	20.57	0.1140
Middle		28.61	0.7261	20.62	0.1153
Highest		28.08	0.6427	20.49	0.1119
Lowest	GSM850 EDGE class 8	23.61	0.2296	15.33	0.0341
Middle		23.49	0.2234	15.79	0.0379
Highest		22.71	0.1866	15.33	0.0341
Lowest	WCDMA Band V RMC 12.2Kbps	19.21	0.0834	10.66	0.0116
Middle		19.03	0.0800	10.83	0.0121
Highest		19.11	0.0815	11.39	0.0138
Limit	ERP < 7W	Result		PASS	

Channel	Mode	Horizontal		Vertical	
		EIRP(dBm)	EIRP(W)	EIRP(dBm)	EIRP(W)
Lowest	GSM1900 GSM	31.77	1.5031	32.27	1.6866
Middle		31.76	1.4997	32.16	1.6444
Highest		31.50	1.4125	31.88	1.5417
Lowest	GSM1900 EDGE class 8	28.47	0.7031	28.93	0.7816
Middle		28.13	0.6501	28.60	0.7244
Highest		27.68	0.5861	28.27	0.6714
Lowest	WCDMA Band II RMC 12.2Kbps	24.97	0.3141	25.29	0.3381
Middle		24.71	0.2958	24.98	0.3148
Highest		24.74	0.2979	25.09	0.3228
Limit	EIRP < 2W	Result		PASS	



Radiated Spurious Emission

GSM850 (GSM)									
Channel	Frequency (MHz)	ERP (dBm)	Limit (dBm)	Over Limit (dB)	SPA Reading (dBm)	S.G. Power (dBm)	TX Cable loss (dB)	TX Antenna Gain (dBi)	Polarization (H/V)
Middle	1672	-43.45	-13	-30.45	-47.81	-47.27	0.53	6.50	H
	2510	-42.68	-13	-29.68	-49.49	-45.55	0.68	5.70	H
	3346	-53.75	-13	-40.75	-63.77	-58.79	0.81	8.00	H
	4182	-48.83	-13	-35.83	-61.09	-55.04	0.84	9.20	H
	1672	-38.91	-13	-25.91	-44.95	-42.73	0.53	6.50	V
	2510	-46.61	-13	-33.61	-52.72	-49.48	0.68	5.70	V
	3346	-53.60	-13	-40.60	-62.61	-58.64	0.81	8.00	V
	4182	-52.78	-13	-39.78	-65.30	-58.99	0.84	9.20	V

Remark: Spurious emissions within 30-1000MHz were found more than 20dB below limit line.

GSM850 (EDGE class 8)									
Channel	Frequency (MHz)	ERP (dBm)	Limit (dBm)	Over Limit (dB)	SPA Reading (dBm)	S.G. Power (dBm)	TX Cable loss (dB)	TX Antenna Gain (dBi)	Polarization (H/V)
Middle	1672	-50.33	-13	-37.33	-53.55	-54.15	0.53	6.50	H
	2510	-49.98	-13	-36.98	-55.44	-52.85	0.68	5.70	H
	3346	-56.10	-13	-43.10	-66.12	-61.14	0.81	8.00	H
	1672	-50.18	-13	-37.18	-54.43	-54.00	0.53	6.50	V
	2510	-55.41	-13	-42.41	-59.73	-58.28	0.68	5.70	V
	3346	-57.19	-13	-44.19	-66.20	-62.23	0.81	8.00	V

Remark: Spurious emissions within 30-1000MHz were found more than 20dB below limit line.



GSM1900 (GSM)									
Channel	Frequency (MHz)	EIRP (dBm)	Limit (dBm)	Over Limit (dB)	SPA Reading (dBm)	S.G. Power (dBm)	TX Cable loss (dB)	TX Antenna Gain (dBi)	Polarization (H/V)
Middle	3760	-48.66	-13	-35.66	-61.43	-55.85	0.81	8.00	H
	5640	-47.16	-13	-34.16	-65.91	-57.15	1.01	11.00	H
	7520	-47.88	-13	-34.88	-70.05	-60.12	1.46	13.70	H
	3760	-48.69	-13	-35.69	-61.76	-55.88	0.81	8	V
	5640	-46.01	-13	-33.01	-65.07	-56.00	1.01	11	V
	7520	-47.23	-13	-34.23	-69.72	-59.47	1.46	13.7	V

Remark: Spurious emissions within 30-1000MHz were found more than 20dB below limit line.

GSM1900 (EDGE class 8)									
Channel	Frequency (MHz)	EIRP (dBm)	Limit (dBm)	Over Limit (dB)	SPA Reading (dBm)	S.G. Power (dBm)	TX Cable loss (dB)	TX Antenna Gain (dBi)	Polarization (H/V)
Middle	3760	-52.81	-13	-39.81	-65.58	-60.00	0.81	8.00	H
	5640	-48.06	-13	-35.06	-66.81	-58.05	1.01	11.00	H
	7520	-47.07	-13	-34.07	-69.24	-59.31	1.46	13.70	H
	3760	-52.57	-13	-39.57	-65.64	-59.76	0.81	8	V
	5640	-48.11	-13	-35.11	-67.17	-58.10	1.01	11	V
	7520	-46.87	-13	-33.87	-69.36	-59.11	1.46	13.7	V

Remark: Spurious emissions within 30-1000MHz were found more than 20dB below limit line.



WCDMA Band V(RMC 12.2Kbps)									
Channel	Frequency (MHz)	ERP (dBm)	Limit (dBm)	Over Limit (dB)	SPA Reading (dBm)	S.G. Power (dBm)	TX Cable loss (dB)	TX Antenna Gain (dBi)	Polarization (H/V)
Middle	1672	-59.17	-13	-46.17	-61.72	-62.99	0.53	6.50	H
	2510	-56.36	-13	-43.36	-61.78	-59.23	0.68	5.70	H
	3346	-56.47	-13	-43.47	-66.49	-61.51	0.81	8.00	H
	1672	-59.67	-13	-46.67	-62.58	-63.49	0.53	6.50	V
	2510	-59.44	-13	-46.44	-63.76	-62.31	0.68	5.70	V
	3346	-56.33	-13	-43.33	-65.34	-61.37	0.81	8.00	V

Remark: Spurious emissions within 30-1000MHz were found more than 20dB below limit line.

WCDMA Band II(RMC 12.2Kbps)									
Channel	Frequency (MHz)	EIRP (dBm)	Limit (dBm)	Over Limit (dB)	SPA Reading (dBm)	S.G. Power (dBm)	TX Cable loss (dB)	TX Antenna Gain (dBi)	Polarization (H/V)
Middle	3760	-51.56	-13	-38.56	-64.33	-58.75	0.81	8.00	H
	5640	-43.77	-13	-30.77	-62.52	-53.76	1.01	11.00	H
	7520	-46.95	-13	-33.95	-69.12	-59.19	1.46	13.70	H
	3760	-52.73	-13	-39.73	-65.8	-59.92	0.81	8	V
	5640	-42.41	-13	-29.41	-61.47	-52.40	1.01	11	V
	7520	-45.94	-13	-32.94	-68.43	-58.18	1.46	13.7	V

Remark: Spurious emissions within 30-1000MHz were found more than 20dB below limit line.