

FCC RF Test Report

APPLICANT : Brightstar Corporation
EQUIPMENT : Mobile phone
BRAND NAME : Avvio
MODEL NAME : Avvio L500
FCC ID : WVBAL500
STANDARD : FCC Part 15 Subpart C §15.247
CLASSIFICATION : (DTS) Digital Transmission System

The product was testing completed on May 29, 2014. We, SPORTON INTERNATIONAL (SHENZHEN) INC., would like to declare that the tested sample has been evaluated in accordance with the test procedures and has been in compliance with the applicable technical standards.

The test results in this report apply exclusively to the tested model / sample. Without written approval of SPORTON INTERNATIONAL (SHENZHEN) INC., the test report shall not be reproduced except in full.



Reviewed by: Joseph Lin / Supervisor



Approved by: Jones Tsai / Manager



SPORTON INTERNATIONAL (SHENZHEN) INC.

No. 3 Building, the third floor of south, Shahe River west, Fengzeyuan warehouse, Nanshan District, Shenzhen, Guangdong, P. R. C.



TABLE OF CONTENTS

REVISION HISTORY..... 3

SUMMARY OF TEST RESULT 4

1 GENERAL DESCRIPTION 5

 1.1 Applicant 5

 1.2 Manufacturer 5

 1.3 Feature of Equipment Under Test 5

 1.4 Product Specification of Equipment Under Test 5

 1.5 Modification of EUT 6

 1.6 Testing Location 6

 1.7 Applicable Standards 6

2 TEST CONFIGURATION OF EQUIPMENT UNDER TEST 7

 2.1 Carrier Frequency Channel 7

 2.2 Pre-Scanned RF Power 8

 2.3 Test Mode 9

 2.4 Connection Diagram of Test System 10

 2.5 Support Unit used in test configuration and system 11

 2.6 EUT Operation Test Setup 11

 2.7 Measurement Results Explanation Example 11

3 TEST RESULT 12

 3.1 6dB Bandwidth Measurement 12

 3.2 Output Power Measurement 14

 3.3 Power Spectral Density Measurement 17

 3.4 Conducted Band Edges and Spurious Emission Measurement 19

 3.5 Radiated Band Edges and Spurious Emission Measurement 32

 3.6 AC Conducted Emission Measurement 54

 3.7 Antenna Requirements 58

4 LIST OF MEASURING EQUIPMENT 59

5 UNCERTAINTY OF EVALUATION 60

APPENDIX A. SETUP PHOTOGRAPHS



REVISION HISTORY

REPORT NO.	VERSION	DESCRIPTION	ISSUED DATE
FR441505C	Rev. 01	Initial issue of report	Jun. 04, 2014

SUMMARY OF TEST RESULT

Report Section	FCC Rule	Description	Limit	Result	Remark
3.1	15.247(a)(2)	6dB Bandwidth	$\geq 0.5\text{MHz}$	Pass	-
3.2	15.247(b)	Power Output Measurement	$\leq 30\text{dBm}$	Pass	-
3.3	15.247(e)	Power Spectral Density	$\leq 8\text{dBm}/3\text{kHz}$	Pass	-
3.4	15.247(d)	Conducted Band Edges	$\leq 20\text{dBc}$	Pass	-
		Conducted Spurious Emission		Pass	-
3.5	15.247(d)	Radiated Band Edges and Radiated Spurious Emission	15.209(a) & 15.247(d)	Pass	Under limit 5.22 dB at 2483.560 MHz
3.6	15.207	AC Conducted Emission	15.207(a)	Pass	Under limit 4.42 dB at 0.150 MHz
3.7	15.203 & 15.247(b)	Antenna Requirement	N/A	Pass	-

1 General Description

1.1 Applicant

Brightstar Corporation

9725 NW 117th Ave., Miami, Florida, FL 33178, United States

1.2 Manufacturer

YULONG COMPUTER TELECOMMUNICATION SCIENTIFIC(SHENZHEN) CO., LTD

Coolpad Information Harbor, 2nd Mengxi Road, High-Tech Industrial Park(North), NanShan District, ShenZhen, P. R. C.

1.3 Feature of Equipment Under Test

Product Feature	
Equipment	Mobile phone
Brand Name	Avvio
Model Name	Avvio L500
FCC ID	WVBAL500
EUT supports Radios application	GSM/GPRS/EGPRS/WCDMA/HSPA/HSPA+ (Downlink Only)/ DC-HSDPA/LTE/WLAN 2.4GHz 802.11b/g/n HT20/HT40/ Bluetooth v3.0 + EDR/Bluetooth v4.0 LE
HW Version	P1
SW Version	P1
EUT Stage	Identical Prototype

Remark: The above EUT's information was declared by manufacturer. Please refer to the specifications or user's manual for more detailed description.

1.4 Product Specification of Equipment Under Test

Product Specification subjective to this standard	
Tx/Rx Channel Frequency Range	2412 MHz ~ 2462 MHz
Maximum (Peak) Output Power to Antenna	802.11b : 20.49 dBm (0.1119 W) 802.11g : 20.10 dBm (0.1023 W) 802.11n HT20 : 19.43 dBm (0.0877 W) 802.11n HT40 : 18.51 dBm (0.0710 W)
Antenna Type	IFA Antenna with gain 3.40 dBi
Type of Modulation	802.11b : DSSS (DBPSK / DQPSK / CCK) 802.11g/n : OFDM (BPSK / QPSK / 16QAM / 64QAM)

1.5 Modification of EUT

No modifications are made to the EUT during all test items.

1.6 Testing Location

Test Site	SPORTON INTERNATIONAL (SHENZHEN) INC.			
Test Site Location	No. 3 Building, the third floor of south, Shahe River west, Fengzeyuan warehouse, Nanshan District, Shenzhen, Guangdong, P. R. C. TEL: +86-755- 3320-2398			
Test Site No.	Sporton Site No.			FCC Registration No.
	TH01-SZ	03CH01-SZ	CO01-SZ	831040

Note: The test site complies with ANSI C63.4 2003 requirement.

1.7 Applicable Standards

According to the specifications of the manufacturer, the EUT must comply with the requirements of the following standards:

- ♦ FCC Part 15 Subpart C §15.247
- ♦ FCC KDB Publication No. 558074 D01 DTS Meas. Guidance v03r01
- ♦ ANSI C63.4-2003

Remark:

1. All test items were verified and recorded according to the standards and without any deviation during the test.
2. This EUT has also been tested and complied with the requirements of FCC Part 15, Subpart B, recorded in a separate test report.

2 Test Configuration of Equipment Under Test

The EUT has been associated with peripherals and configuration operated in a manner tended to maximize its emission characteristics in a typical application. Frequency range investigated: conducted emission (150 kHz to 30 MHz) and radiated emission (9 kHz to the 10th harmonic of the highest fundamental frequency or to 40 GHz, whichever is lower). For radiated measurement, pre-scanned in three orthogonal panels, X, Y, Z. The worst cases (Z plane) were recorded in this report.

The final configuration from all the combinations and the worst-case data rates were investigated by measuring the maximum power across all the data rates and modulation modes under section 2.2.

Based on the worst configuration found above, the RF power setting is set individually to meet FCC compliance limit for the final conducted and radiated tests shown in section 2.3.

2.1 Carrier Frequency Channel

Frequency Band	Channel	Freq. (MHz)	Channel	Freq. (MHz)
2400-2483.5 MHz	1	2412	7	2442
	2	2417	8	2447
	3	2422	9	2452
	4	2427	10	2457
	5	2432	11	2462
	6	2437	-	-

2.2 Pre-Scanned RF Power

Preliminary tests were performed in different data rate and data rate associated with the highest power were chosen for full test shown in the following tables.

WLAN 2.4GHz 802.11b Peak Power (dBm)						
Power vs. Channel			Power vs. Data Rate			
Channel	Frequency (MHz)	Data Rate 1Mbps	Channel	2Mbps	5.5Mbps	11Mbps
CH 01	2412 MHz	19.05	CH 06	20.45	20.43	20.47
CH 06	2437 MHz	20.49				
CH 11	2462 MHz	19.98				

WLAN 2.4GHz 802.11g Peak Power (dBm)										
Power vs. Channel			Power vs. Data Rate							
Channel	Frequency (MHz)	Data Rate 6Mbps	Channel	9Mbps	12Mbps	18Mbps	24Mbps	36Mbps	48Mbps	54Mbps
CH 01	2412 MHz	18.92	CH 06	20.08	20.07	20.05	20.03	20.02	20.04	20.03
CH 06	2437 MHz	20.10								
CH 11	2462 MHz	19.72								

WLAN 2.4GHz 802.11n-HT20 Peak Power (dBm)										
Power vs. Channel			Power vs. MCS Index							
Channel	Frequency (MHz)	MCS Index MCS0	Channel	MCS1	MCS2	MCS3	MCS4	MCS5	MCS6	MCS7
CH 01	2412 MHz	17.71	CH 06	18.35	18.33	18.29	18.27	18.25	18.21	18.17
CH 06	2437 MHz	19.43								
CH 11	2462 MHz	18.97								

WLAN 2.4GHz 802.11n-HT40 Peak Power (dBm)										
Power vs. Channel			Power vs. MCS Index							
Channel	Frequency (MHz)	MCS Index MCS0	Channel	MCS1	MCS2	MCS3	MCS4	MCS5	MCS6	MCS7
CH 03	2422 MHz	17.76	CH 09	18.45	18.50	18.48	18.41	18.44	18.37	18.40
CH 06	2437 MHz	18.04								
CH 09	2452 MHz	18.51								

2.3 Test Mode

Final results of test modes, data rates and test channels are shown as following table.

Test Cases				
	Test Items	Mode	Data Rate	Test Channel
Conducted TCs	6dB BW Power Spectral Density	802.11b	1 Mbps	1/6/11
		802.11g	6 Mbps	1/6/11
		802.11n HT20	MCS0	1/6/11
		802.11n HT40	MCS0	3/6/9
	Output Power	802.11b	1 Mbps	1/6/11
		802.11g	6 Mbps	1/6/11
		802.11n HT20	MCS0	1/6/11
		802.11n HT40	MCS0	3/6/9
	Conducted Band Edge	802.11b	1 Mbps	1/11
		802.11g	6 Mbps	1/11
		802.11n HT20	MCS0	1/11
		802.11n HT40	MCS0	3/9
	Conducted Spurious Emission	802.11b	1 Mbps	1/6/11
		802.11g	6 Mbps	1/6/11
		802.11n HT20	MCS0	1/6/11
		802.11n HT40	MCS0	3/6/9
Radiated TCs	Radiated Band Edge	802.11b	1 Mbps	1/11
		802.11g	6 Mbps	1/11
		802.11n HT20	MCS0	1/11
		802.11n HT40	MCS0	3/9
	Radiated Spurious Emission	802.11b	1 Mbps	1/6/11
		802.11g	6 Mbps	1/6/11
		802.11n HT20	MCS0	1/6/11
		802.11n HT40	MCS0	3/6/9
AC Conducted Emission	Mode 1 : GSM850 Idle + Bluetooth Link + WLAN Link + USB Cable (Charging from Adapter) + Earphone			
Remark: For radiated TCs, the tests were performed with adapter, earphone and USB cable.				

2.4 Connection Diagram of Test System

<WLAN Tx Mode>

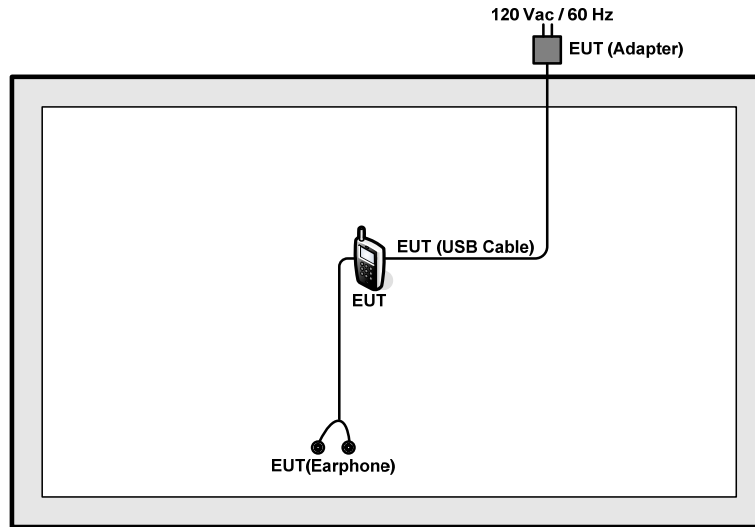

<AC Conducted Emission Mode>

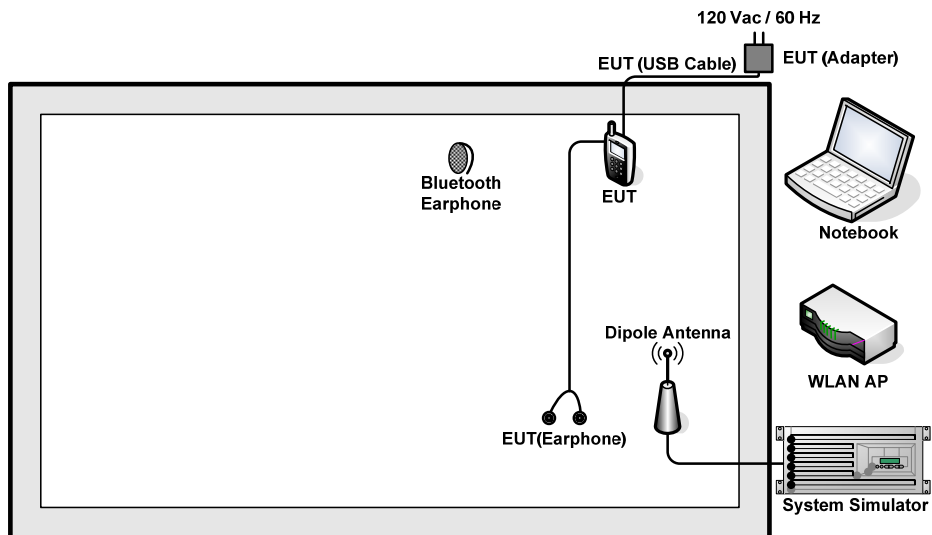

2.5 Support Unit used in test configuration and system

Item	Equipment	Trade Name	Model Name	FCC ID	Data Cable	Power Cord
1.	System Simulator	R&S	CMW 500	N/A	N/A	Unshielded, 1.8 m
2.	WLAN AP	D-Link	DIR-815	KA2DIR815A1	N/A	Unshielded, 1.8 m
3.	Notebook	Lenovo	G480	FCC DoC	N/A	AC I/P: Unshielded, 1.2 m DC O/P: Shielded, 1.8 m
4.	Bluetooth Earphone	Nokia	BH-108	PYAHS-107W	N/A	N/A

2.6 EUT Operation Test Setup

For WLAN function, the engineering test program was provided and enabled to make EUT continuous transmit/receive.

For AC power line conducted emissions, the EUT was set to connect with the WLAN AP under large package sizes transmission.

2.7 Measurement Results Explanation Example

For all conducted test items:

The offset level is set in the spectrum analyzer to compensate the RF cable loss and attenuator factor between EUT conducted output port and spectrum analyzer. With the offset compensation, the spectrum analyzer reading level is exactly the EUT RF output level.

Example:

The spectrum analyzer offset is derived from RF cable loss and attenuator factor.

Offset = RF cable loss + attenuator factor.

Following shows an offset computation example with cable loss 7.5 dB and 10dB attenuator.

$$\begin{aligned} \text{Offset (dB)} &= \text{RF cable loss(dB)} + \text{attenuator factor(dB)}. \\ &= 7.5 + 10 = 17.5 \text{ (dB)} \end{aligned}$$

3 Test Result

3.1 6dB Bandwidth Measurement

3.1.1 Limit of 6dB Bandwidth

The minimum 6 dB bandwidth shall be at least 500 kHz.

3.1.2 Measuring Instruments

The measuring equipment is listed in the section 4 of this test report.

3.1.3 Test Procedures

1. The testing follows FCC KDB Publication No. 558074 DTS D01 Meas. Guidance v03r01.
2. The RF output of EUT was connected to the spectrum analyzer by RF cable and attenuator. The path loss was compensated to the results for each measurement.
3. Set to the maximum power setting and enable the EUT transmit continuously.
4. Make the measurement with the spectrum analyzer's resolution bandwidth (RBW) = 100 kHz. Set the Video bandwidth (VBW) = 300 kHz. In order to make an accurate measurement. The 6 dB bandwidth must be greater than 500 kHz.
5. Measure and record the results in the test report.

3.1.4 Test Setup

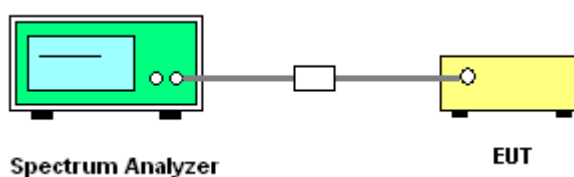



3.1.5 Test Result of 6dB Bandwidth

Test Band :	2.4GHz	Temperature :	24~26°C
Test Engineer :	Blithe Li	Relative Humidity :	50~53%

Mod.	Data Rate	N _{TX}	Channel	Freq. (MHz)	6dB Bandwidth (MHz)	6dB Bandwidth Min. Limit (MHz)	Pass/Fail
11b	1Mbps	1	1	2412	7.08	0.50	Pass
11b	1Mbps	1	6	2437	7.08	0.50	Pass
11b	1Mbps	1	11	2462	7.56	0.50	Pass
11g	6Mbps	1	1	2412	16.32	0.50	Pass
11g	6Mbps	1	6	2437	16.32	0.50	Pass
11g	6Mbps	1	11	2462	16.36	0.50	Pass
HT20	MCS0	1	1	2412	17.56	0.50	Pass
HT20	MCS0	1	6	2437	17.56	0.50	Pass
HT20	MCS0	1	11	2462	17.56	0.50	Pass
HT40	MCS0	1	3	2422	35.28	0.50	Pass
HT40	MCS0	1	6	2437	35.12	0.50	Pass
HT40	MCS0	1	9	2452	35.36	0.50	Pass

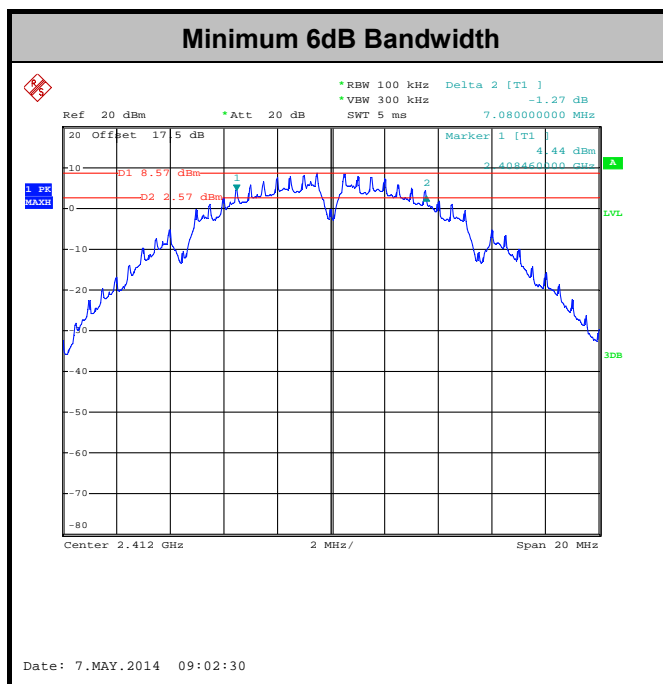

Note: The occupied channel bandwidth is maintained within the band of operation for all of the modulations.

3.2 Output Power Measurement

3.2.1 Limit of Output Power

For systems using digital modulation in the 2400-2483.5MHz, the limit for peak output power is 30dBm. If transmitting Antenna of directional gain greater than 6dBi are used the peak output power from the intentional radiator shall be reduced below the above stated value by the amount in dB that the directional gain of the Antenna exceeds 6 dBi. In case of point-to-point operation, the limit has to be reduced by 1dB for every 3dB that the directional gain of the Antenna exceeds 6dBi.

3.2.2 Measuring Instruments

The measuring equipment is listed in the section 4 of this test report.

3.2.3 Test Procedures

1. The testing follows the Measurement Procedure of FCC KDB No. 558074 DTS D01 Meas. Guidance v03r01.
2. The RF output of EUT was connected to the power meter by RF cable and attenuator. The path loss was compensated to the results for each measurement.
3. Set to the maximum power setting and enable the EUT transmit continuously.
4. Measure the conducted output power and record the results in the test report.

3.2.4 Test Setup

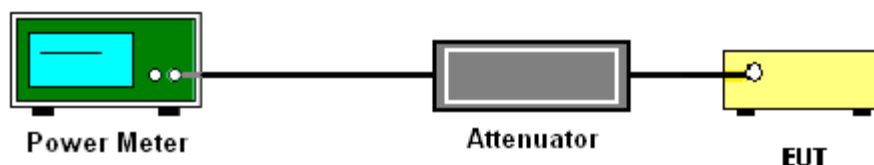



3.2.5 Test Result of Peak Output Power

Test Mode :	2.4GHz	Temperature :	24~26°C
Test Engineer :	Blithe Li	Relative Humidity :	50~53%

Mod.	Data Rate	N _{TX}	Channel	Freq. (MHz)	RF Output Power (dBm)	Power Limit (dBm)	DG (dBi)	Pass/Fail
11b	1Mbps	1	1	2412	19.05	30.00	3.40	Pass
11b	1Mbps	1	6	2437	20.49	30.00	3.40	Pass
11b	1Mbps	1	11	2462	19.98	30.00	3.40	Pass
11g	6Mbps	1	1	2412	18.92	30.00	3.40	Pass
11g	6Mbps	1	6	2437	20.10	30.00	3.40	Pass
11g	6Mbps	1	11	2462	19.72	30.00	3.40	Pass
HT20	MCS0	1	1	2412	17.71	30.00	3.40	Pass
HT20	MCS0	1	6	2437	19.43	30.00	3.40	Pass
HT20	MCS0	1	11	2462	18.97	30.00	3.40	Pass
HT40	MCS0	1	3	2422	17.76	30.00	3.40	Pass
HT40	MCS0	1	6	2437	18.04	30.00	3.40	Pass
HT40	MCS0	1	9	2452	18.51	30.00	3.40	Pass

Note: Measured power (dBm) has offset with cable loss.



3.2.6 Test Result of Average output Power (Reporting Only)

Test Mode :	2.4GHz	Temperature :	24~26°C
Test Engineer :	Blithe Li	Relative Humidity :	50~53%

Mod.	Data Rate	N _{TX}	Channel	Freq. (MHz)	Duty Factor (dB)	Average Output Power (dBm)	Power Limit (dBm)	DG (dBi)	Pass/Fail
11b	1Mbps	1	1	2412	0.10	16.12	30.00	3.40	Pass
11b	1Mbps	1	6	2437	0.10	17.81	30.00	3.40	Pass
11b	1Mbps	1	11	2462	0.10	17.14	30.00	3.40	Pass
11g	6Mbps	1	1	2412	0.62	9.43	30.00	3.40	Pass
11g	6Mbps	1	6	2437	0.62	11.29	30.00	3.40	Pass
11g	6Mbps	1	11	2462	0.62	10.38	30.00	3.40	Pass
HT20	MCS0	1	1	2412	0.67	8.36	30.00	3.40	Pass
HT20	MCS0	1	6	2437	0.67	10.29	30.00	3.40	Pass
HT20	MCS0	1	11	2462	0.67	9.41	30.00	3.40	Pass
HT40	MCS0	1	3	2422	1.21	8.03	30.00	3.40	Pass
HT40	MCS0	1	6	2437	1.21	8.86	30.00	3.40	Pass
HT40	MCS0	1	9	2452	1.21	9.16	30.00	3.40	Pass

Note: Measured power (dBm) has offset with cable loss and duty factor.

3.3 Power Spectral Density Measurement

3.3.1 Limit of Power Spectral Density

The peak power spectral density shall not be greater than 8dBm in any 3kHz band at any time interval of continuous transmission.

3.3.2 Measuring Instruments

The measuring equipment is listed in the section 4 of this test report.

3.3.3 Test Procedures

1. The testing follows Measurement Procedure 10.2 Method PKPSD of FCC KDB Publication No. 558074 D01 DTS Meas. Guidance v03r01
2. The RF output of EUT was connected to the spectrum analyzer by RF cable and attenuator. The path loss was compensated to the results for each measurement.
3. Set to the maximum power setting and enable the EUT transmit continuously.
4. Make the measurement with the spectrum analyzer's resolution bandwidth (RBW) = 3 kHz. Video bandwidth VBW = 10 kHz In order to make an accurate measurement, set the span to 1.5 times DTS Channel Bandwidth. (6dB BW)
5. Detector = peak, Sweep time = auto couple, Trace mode = max hold, Allow trace to fully stabilize. Use the peak marker function to determine the maximum power level.
6. Measure and record the results in the test report.

3.3.4 Test Setup

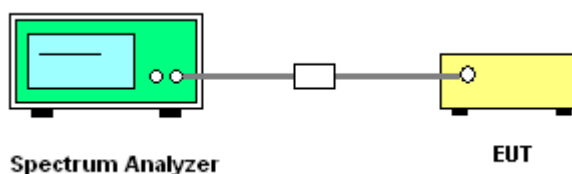

3.3.5 Test Result of Power Spectral Density

Test Mode :	2.4GHz	Temperature :	24~26°C
Test Engineer :	Blithe Li	Relative Humidity :	50~53%

Mod.	Data Rate	N _{TX}	Channel	Freq. (MHz)	Peak Power Density (dBm/3kHz)	Max. Limits (dBm/3kHz)	DG (dBi)	Pass/Fail
11b	1Mbps	1	1	2412	-5.90	8.00	3.40	Pass
11b	1Mbps	1	6	2437	-4.27	8.00	3.40	Pass
11b	1Mbps	1	11	2462	-4.09	8.00	3.40	Pass
11g	6Mbps	1	1	2412	-15.50	8.00	3.40	Pass
11g	6Mbps	1	6	2437	-13.86	8.00	3.40	Pass
11g	6Mbps	1	11	2462	-14.16	8.00	3.40	Pass
HT20	MCS0	1	1	2412	-16.80	8.00	3.40	Pass
HT20	MCS0	1	6	2437	-14.08	8.00	3.40	Pass
HT20	MCS0	1	11	2462	-15.01	8.00	3.40	Pass
HT40	MCS0	1	3	2422	-19.87	8.00	3.40	Pass
HT40	MCS0	1	6	2437	-19.20	8.00	3.40	Pass
HT40	MCS0	1	9	2452	-18.54	8.00	3.40	Pass

Note: Measured power density (dBm) has offset with cable loss.

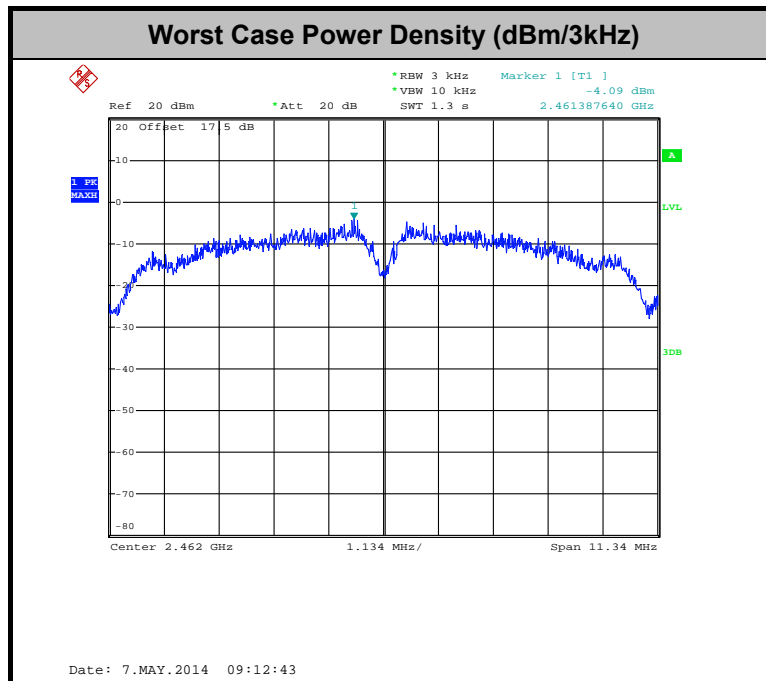

3.4 Conducted Band Edges and Spurious Emission Measurement

3.4.1 Limit of Conducted Band Edges and Spurious Emission Measurement

In any 100 kHz bandwidth outside of the authorized frequency band, the emissions which fall in the non-restricted bands shall be attenuated at least 20 dB / 30dB relative to the maximum PSD level in 100 kHz by RF conducted measurement and radiated emissions which fall in the restricted bands, as defined in Section 15.205(a), must also comply with the radiated emission limits specified in Section 15.209(a).

3.4.2 Measuring Instruments

The measuring equipment is listed in the section 4 of this test report.

3.4.3 Test Procedures

1. The testing follows FCC KDB Publication No. 558074 D01 DTS Meas. Guidance v03r01.
2. The RF output of EUT was connected to the spectrum analyzer by RF cable and attenuator. The path loss was compensated to the results for each measurement.
3. Set to the maximum power setting and enable the EUT transmit continuously.
4. Set RBW = 100 kHz, VBW=300 kHz, Peak Detector. Unwanted Emissions measured in any 100 kHz bandwidth outside of the authorized frequency band shall be attenuated by at least 20 dB relative to the maximum in-band peak PSD level in 100 kHz when maximum peak conducted output power procedure is used. If the transmitter complies with the conducted power limits based on the use of RMS averaging over a time interval, the attenuation required under this paragraph shall be 30 dB instead of 20 dB per 15.247(d).
5. Measure and record the results in the test report.
6. The RF fundamental frequency should be excluded against the limit line in the operating frequency band.

3.4.4 Test Setup

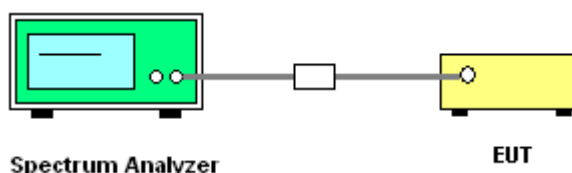



3.4.5 Test Result of Conducted Band Edges and Spurious Emission

Test Mode :	802.11b	Temperature :	24~26°C
Test Band :	2.4GHz Low	Relative Humidity :	50~53%
Test Channel :	01	Test Engineer :	Blithe Li

WLAN 802.11b Channel 01

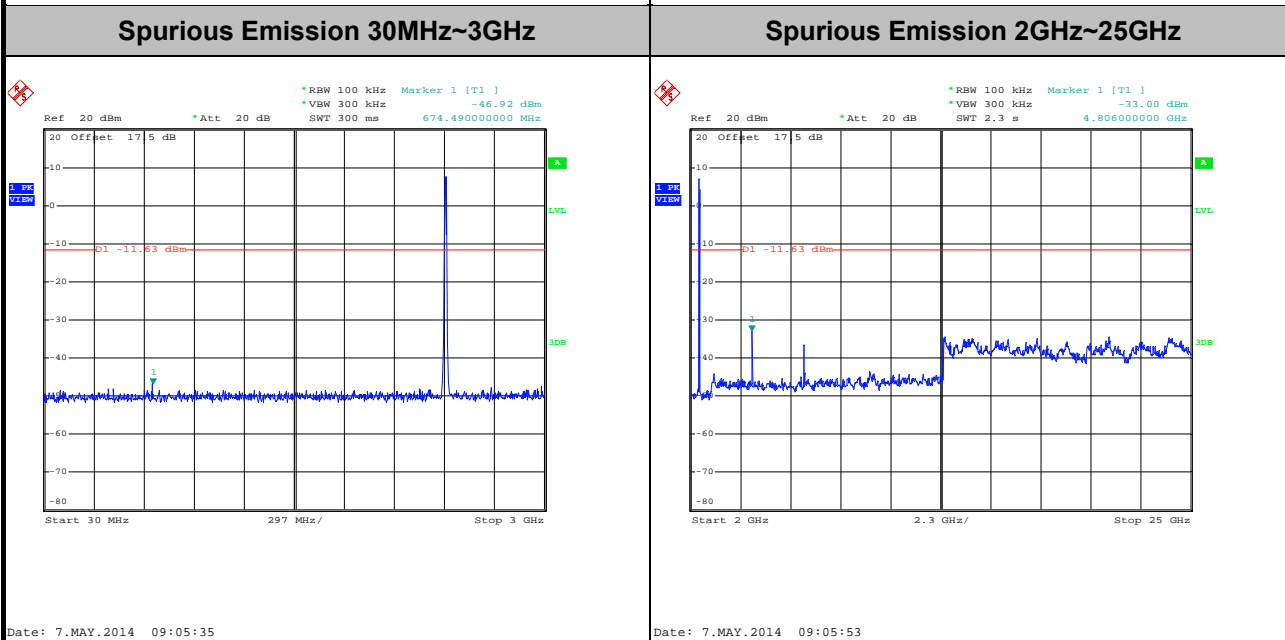
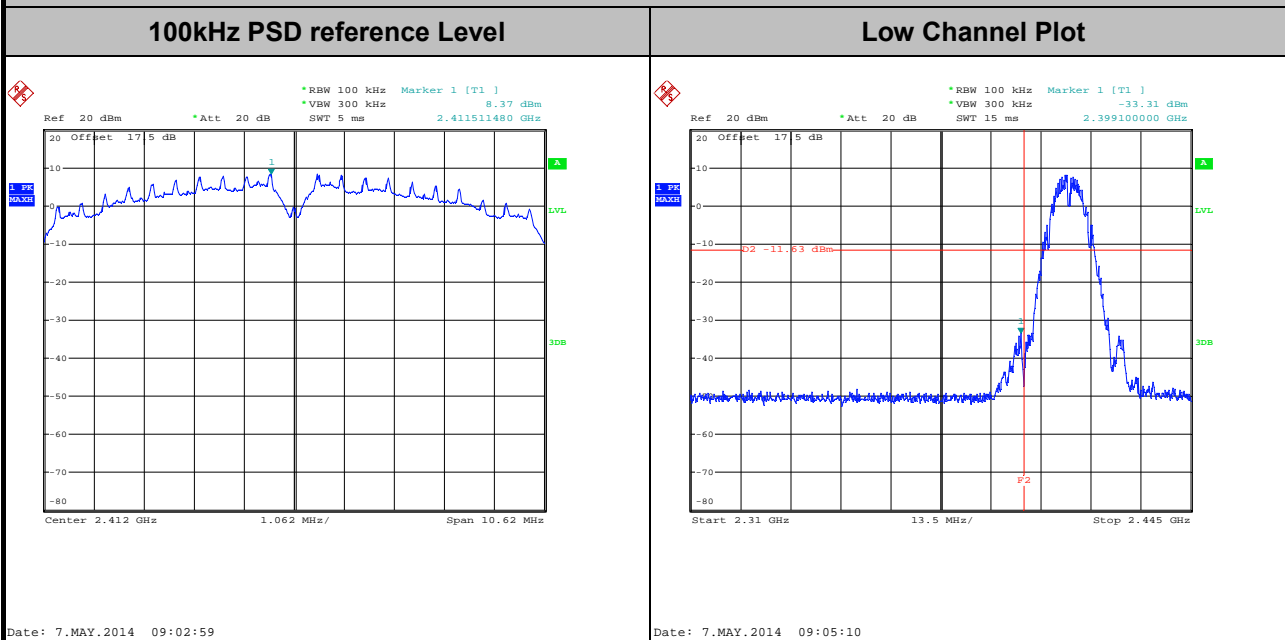



Test Mode :	802.11b	Temperature :	24~26°C
Test Band :	2.4GHz Mid	Relative Humidity :	50~53%
Test Channel :	06	Test Engineer :	Blithe Li

WLAN 802.11b Channel 06

100kHz PSD reference Level

Mid Channel Plot

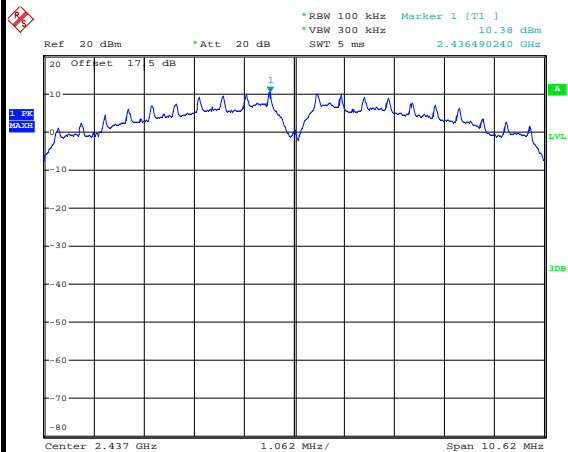

Date: 7.MAY.2014 09:09:09

Spurious Emission 30MHz~3GHz

Spurious Emission 2GHz~25GHz

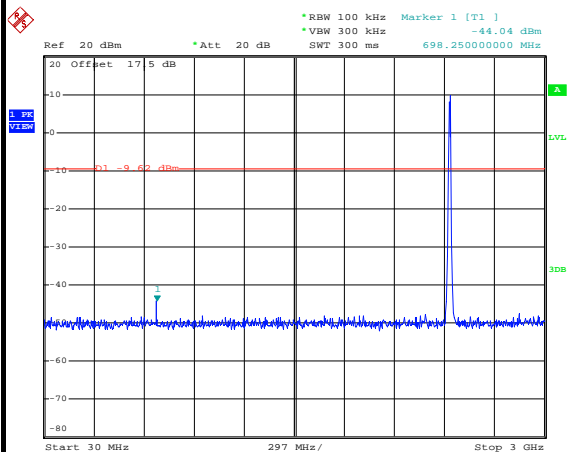

Date: 7.MAY.2014 09:09:28

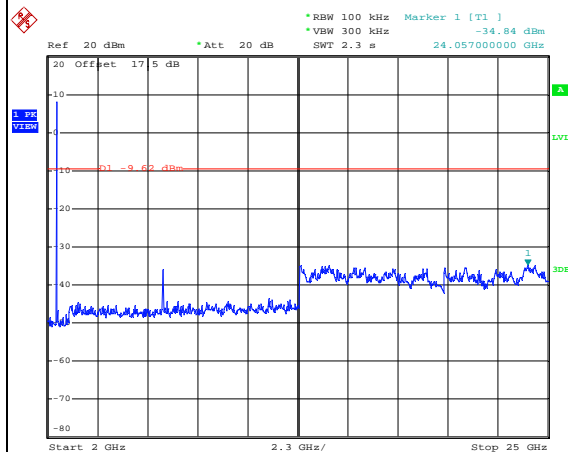

Date: 7.MAY.2014 09:09:47



Test Mode :	802.11b	Temperature :	24~26°C
Test Band :	2.4GHz High	Relative Humidity :	50~53%
Test Channel :	11	Test Engineer :	Blithe Li

WLAN 802.11b Channel 11

100kHz PSD reference Level

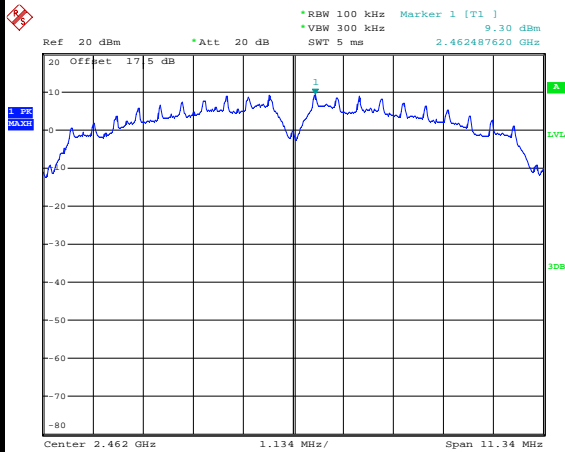

Date: 7.MAY.2014 09:12:52

High Channel Plot

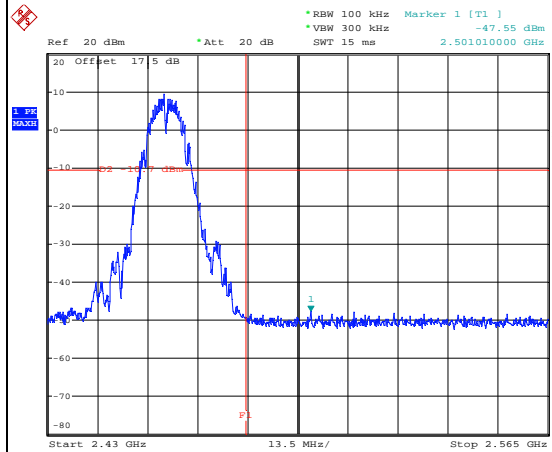

Date: 7.MAY.2014 09:13:06

Spurious Emission 30MHz~3GHz

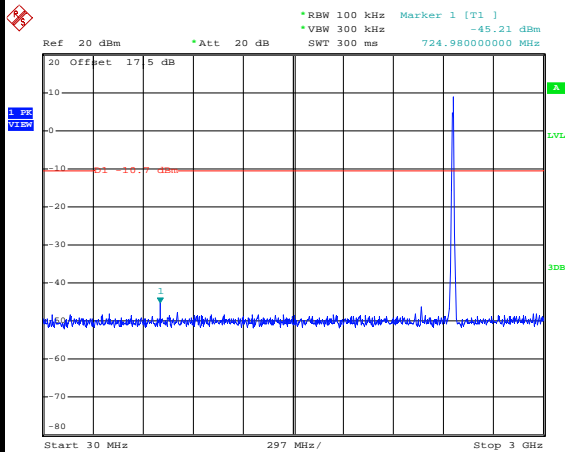

Date: 7.MAY.2014 09:13:25

Spurious Emission 2GHz~25GHz

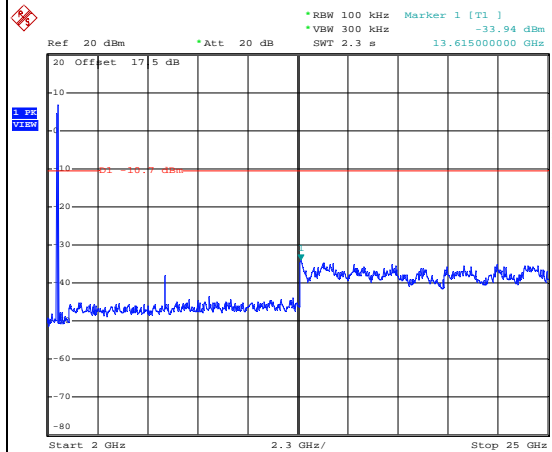

Date: 7.MAY.2014 09:13:44



Test Mode :	802.11g	Temperature :	24~26°C
Test Band :	2.4GHz Low	Relative Humidity :	50~53%
Test Channel :	01	Test Engineer :	Blithe Li

WLAN 802.11g Channel 01

100kHz PSD reference Level

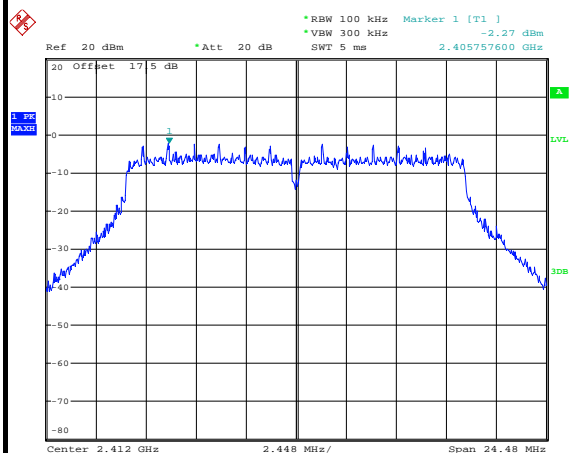

Date: 23.MAY.2014 23:53:49

Low Channel Plot

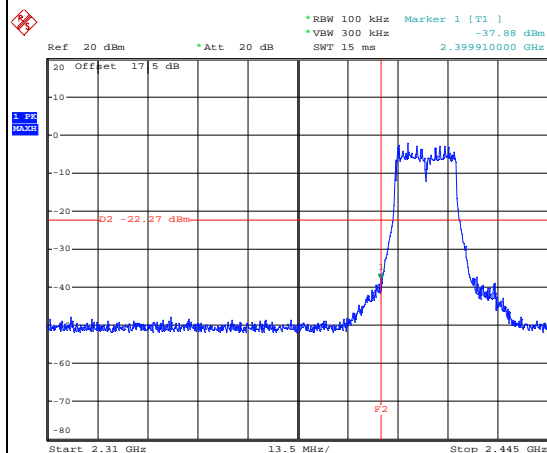

Date: 23.MAY.2014 23:55:37

Spurious Emission 30MHz~3GHz

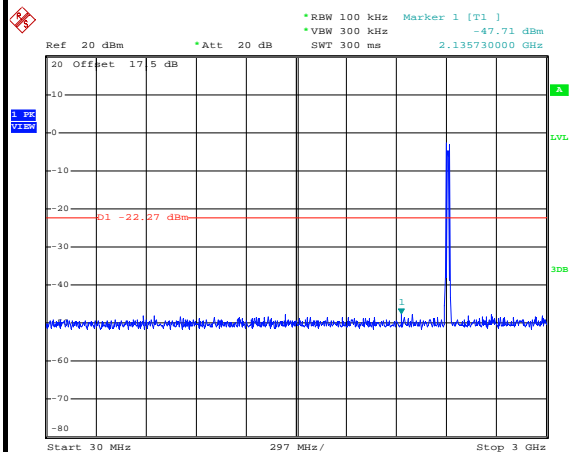

Date: 23.MAY.2014 23:56:14

Spurious Emission 2GHz~25GHz

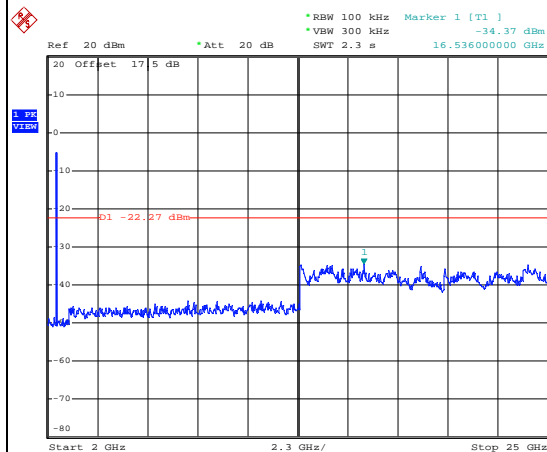

Date: 23.MAY.2014 23:56:33



Test Mode :	802.11g	Temperature :	24~26°C
Test Band :	2.4GHz Mid	Relative Humidity :	50~53%
Test Channel :	06	Test Engineer :	Blithe Li

WLAN 802.11g Channel 06

100kHz PSD reference Level

Mid Channel Plot

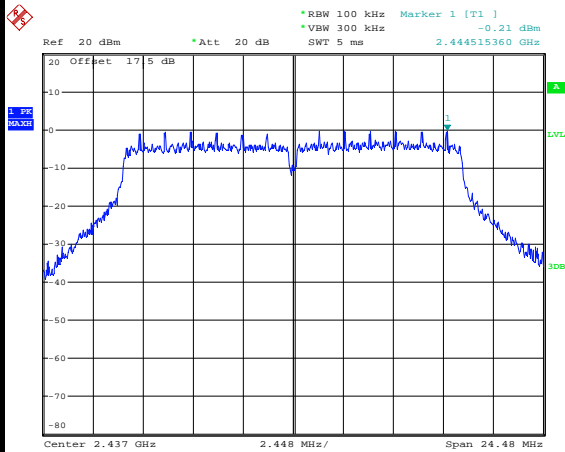

Date: 24.MAY.2014 00:00:29

Spurious Emission 30MHz~3GHz

Spurious Emission 2GHz~25GHz

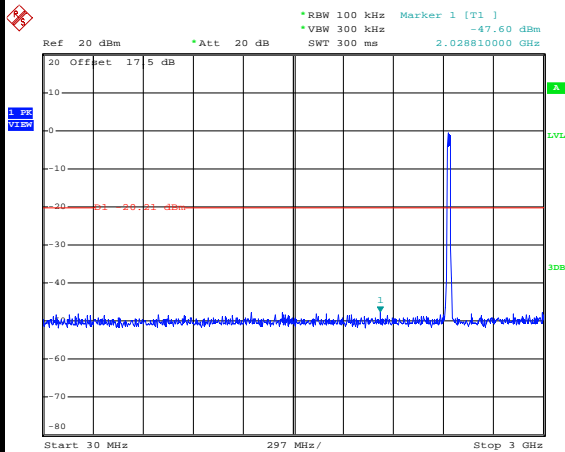

Date: 24.MAY.2014 00:00:49

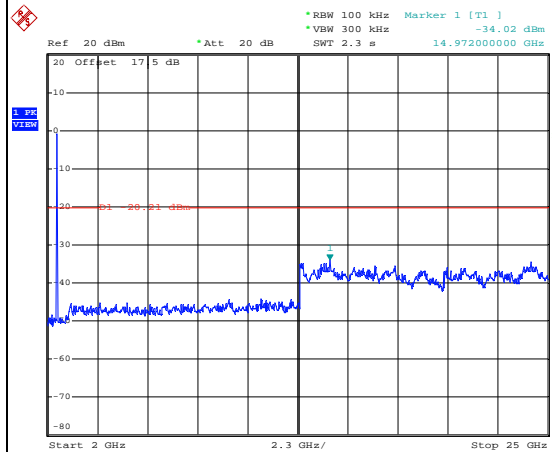

Date: 24.MAY.2014 00:01:08



Test Mode :	802.11g	Temperature :	24~26°C
Test Band :	2.4GHz High	Relative Humidity :	50~53%
Test Channel :	11	Test Engineer :	Blithe Li

WLAN 802.11g Channel 11

100kHz PSD reference Level

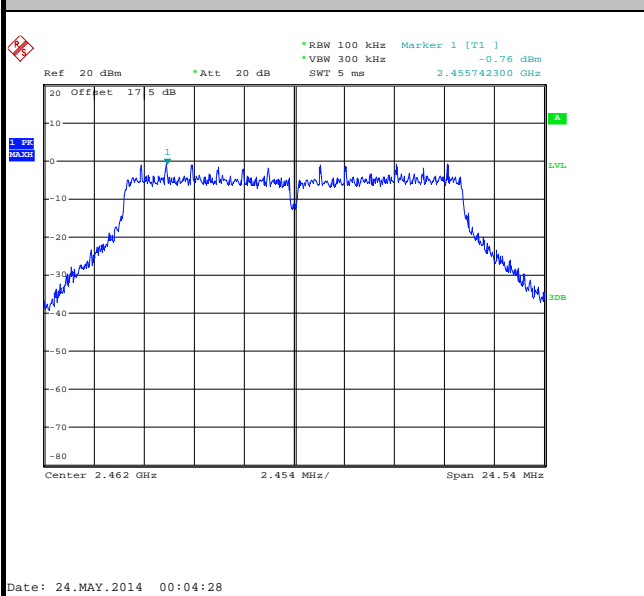

High Channel Plot

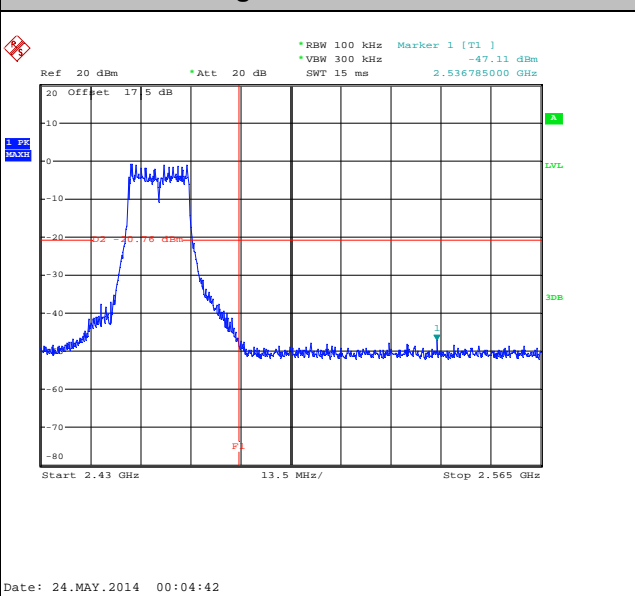

Spurious Emission 30MHz~3GHz

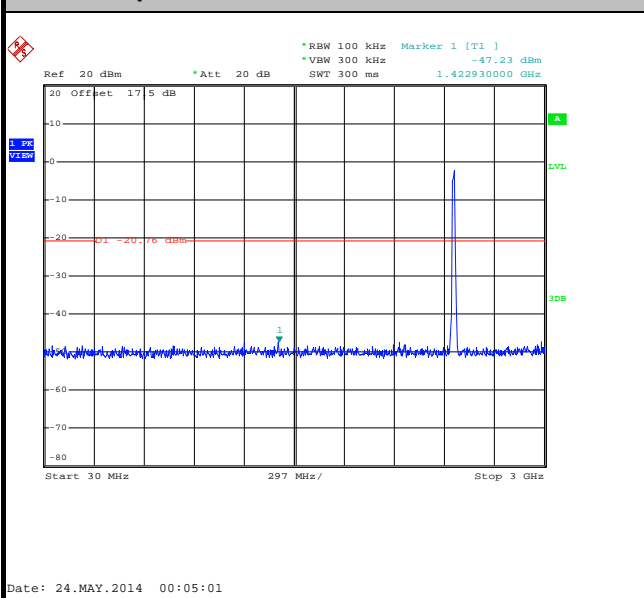

Spurious Emission 2GHz~25GHz

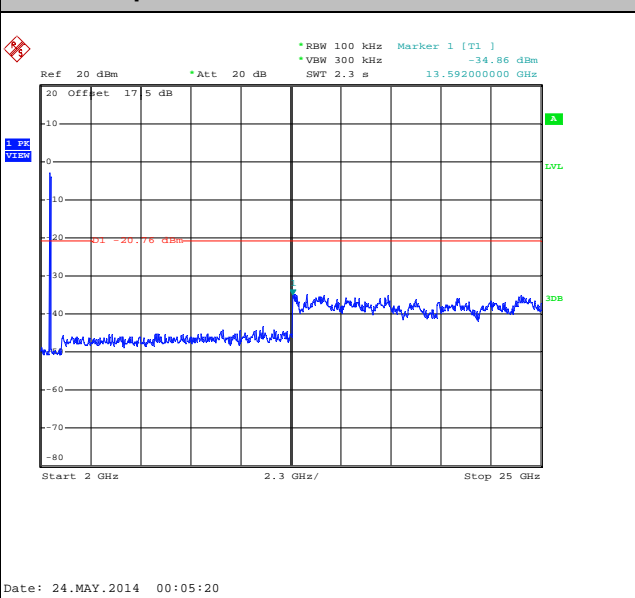



Test Mode :	802.11n HT20	Temperature :	24~26°C
Test Band :	2.4GHz Low	Relative Humidity :	50~53%
Test Channel :	01	Test Engineer :	Blithe Li

WLAN 802.11n HT20 Channel 01

100kHz PSD reference Level

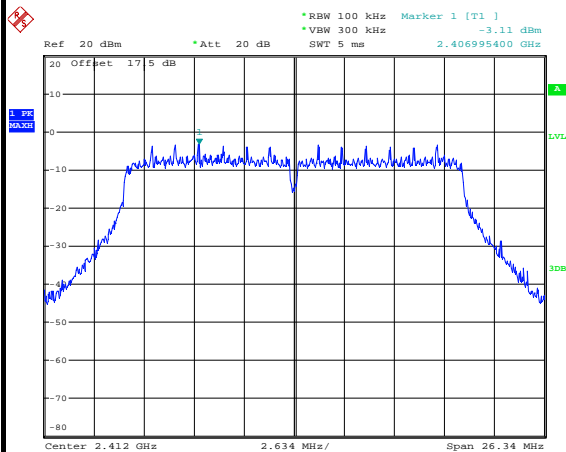

Date: 24.MAY.2014 00:10:08

Low Channel Plot

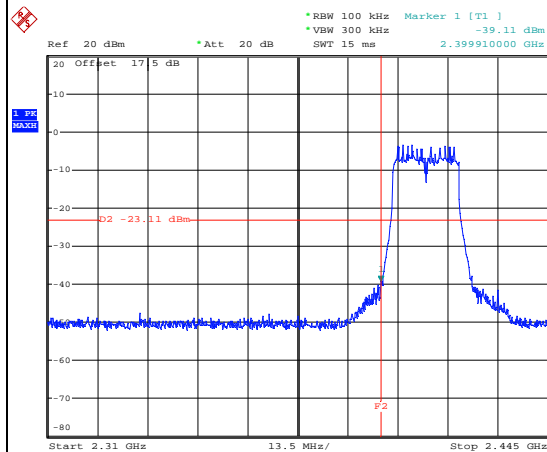

Date: 24.MAY.2014 00:10:22

Spurious Emission 30MHz~3GHz

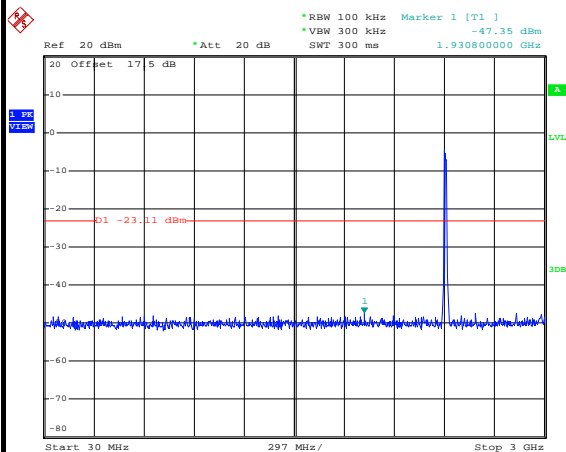

Date: 24.MAY.2014 00:10:41

Spurious Emission 2GHz~25GHz

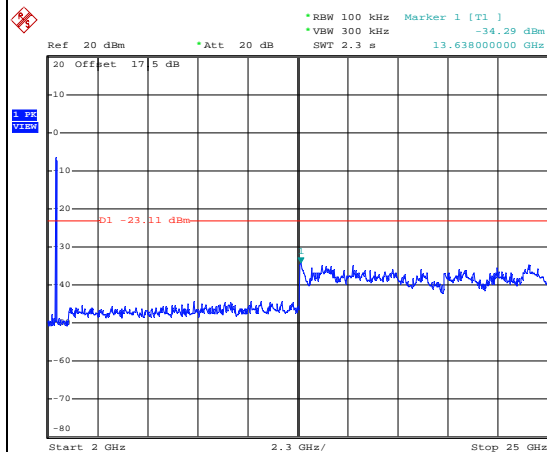

Date: 24.MAY.2014 00:11:00



Test Mode :	802.11n HT20	Temperature :	24~26°C
Test Band :	2.4GHz Mid	Relative Humidity :	50~53%
Test Channel :	06	Test Engineer :	Blithe Li

WLAN 802.11n HT20 Channel 06

100kHz PSD reference Level

Mid Channel Plot

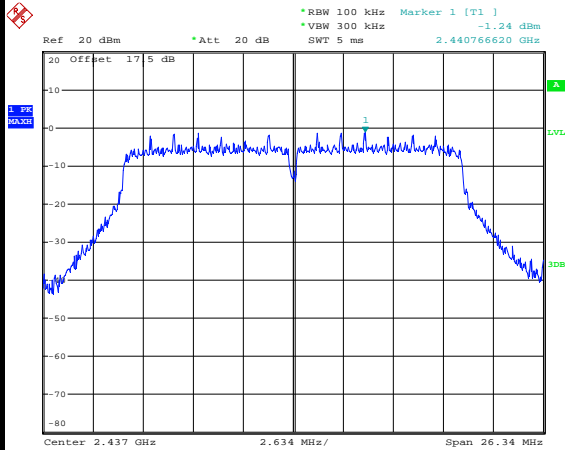

Date: 24.MAY.2014 00:14:02

Spurious Emission 30MHz~3GHz

Spurious Emission 2GHz~25GHz

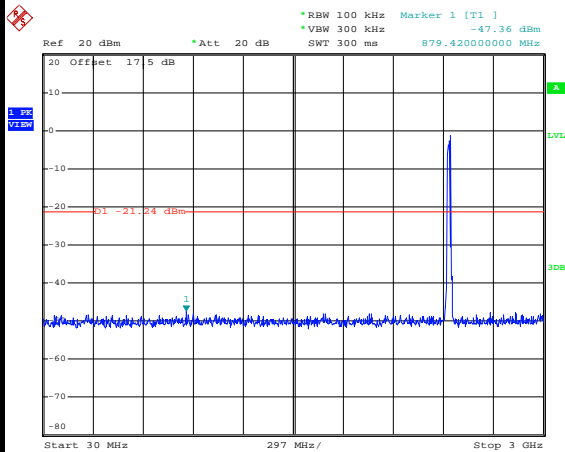

Date: 24.MAY.2014 00:16:00

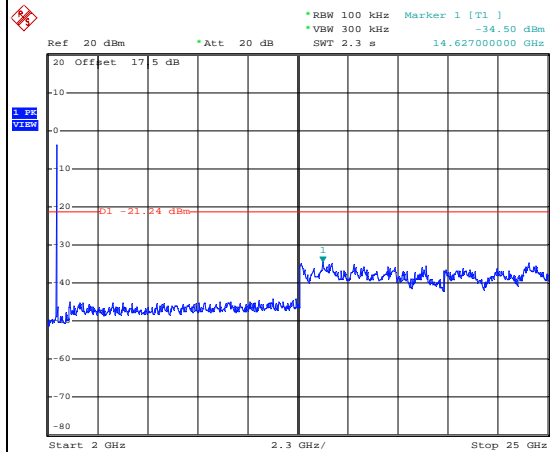

Date: 24.MAY.2014 00:16:18



Test Mode :	802.11n HT20	Temperature :	24~26°C
Test Band :	2.4GHz High	Relative Humidity :	50~53%
Test Channel :	11	Test Engineer :	Blithe Li

WLAN 802.11n HT20 Channel 11

100kHz PSD reference Level

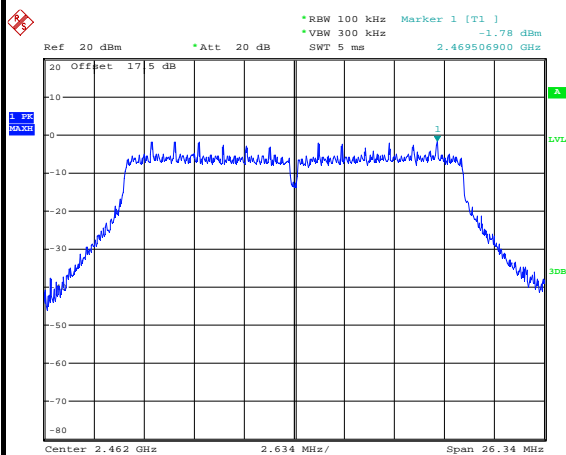

Date: 24.MAY.2014 00:19:15

High Channel Plot

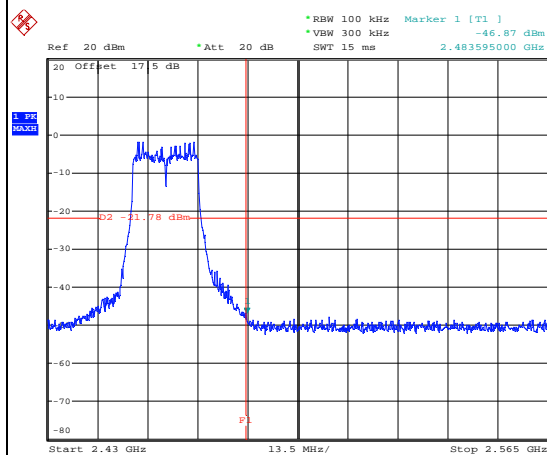

Date: 24.MAY.2014 00:19:29

Spurious Emission 30MHz~3GHz

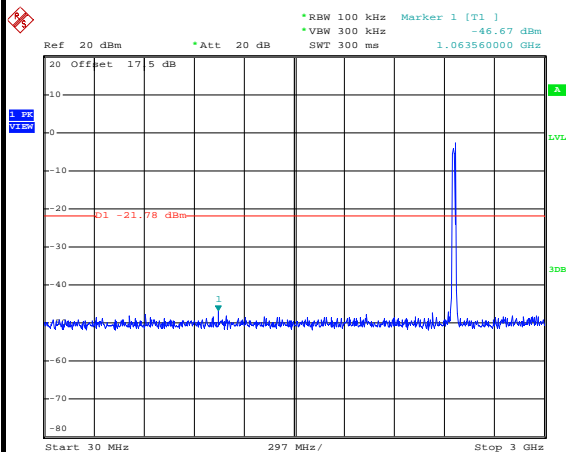

Date: 24.MAY.2014 00:19:49

Spurious Emission 2GHz~25GHz

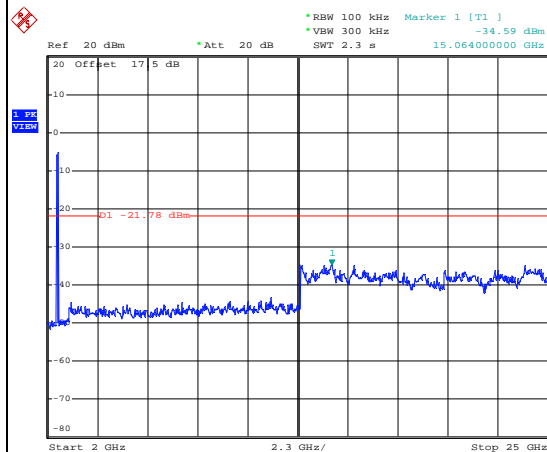

Date: 24.MAY.2014 00:20:07



Test Mode :	802.11n HT40	Temperature :	24~26°C
Test Band :	2.4GHz Low	Relative Humidity :	50~53%
Test Channel :	03	Test Engineer :	Blithe Li

WLAN 802.11n HT40 Channel 03

100kHz PSD reference Level

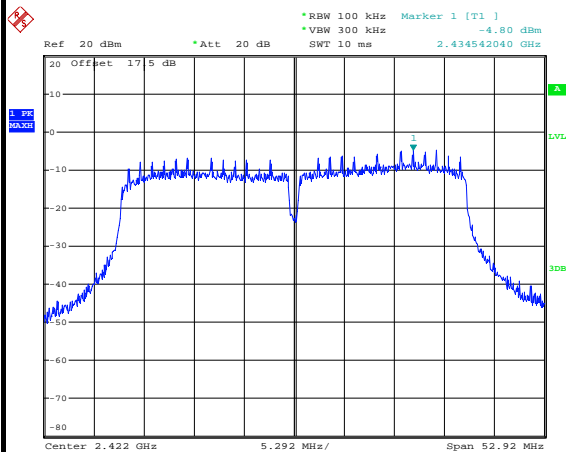

Date: 24.MAY.2014 00:25:17

Low Channel Plot

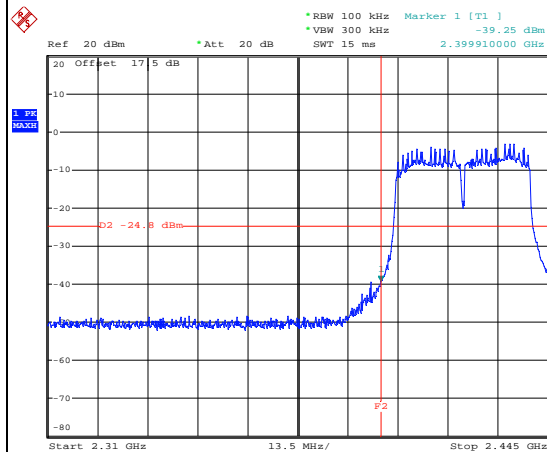

Date: 29.MAY.2014 09:50:49

Spurious Emission 30MHz~3GHz

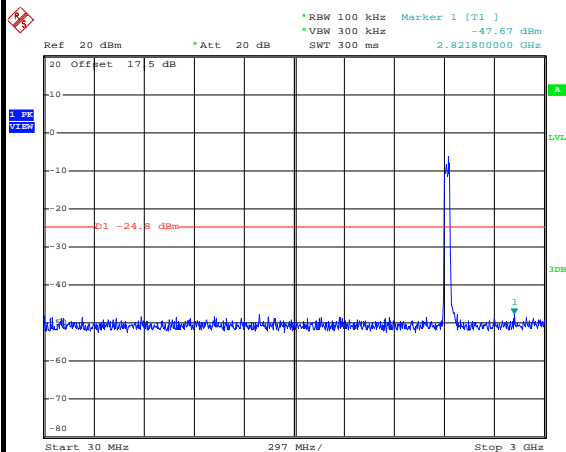

Date: 24.MAY.2014 00:30:34

Spurious Emission 2GHz~25GHz

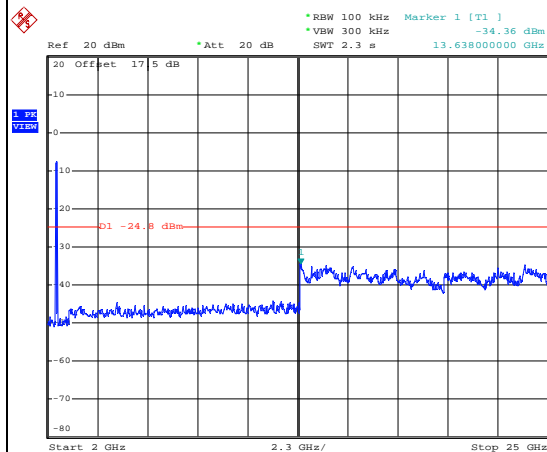

Date: 24.MAY.2014 00:27:33



Test Mode :	802.11n HT40	Temperature :	24~26°C
Test Band :	2.4GHz Mid	Relative Humidity :	50~53%
Test Channel :	06	Test Engineer :	Blithe Li

WLAN 802.11n HT40 Channel 06

100kHz PSD reference Level

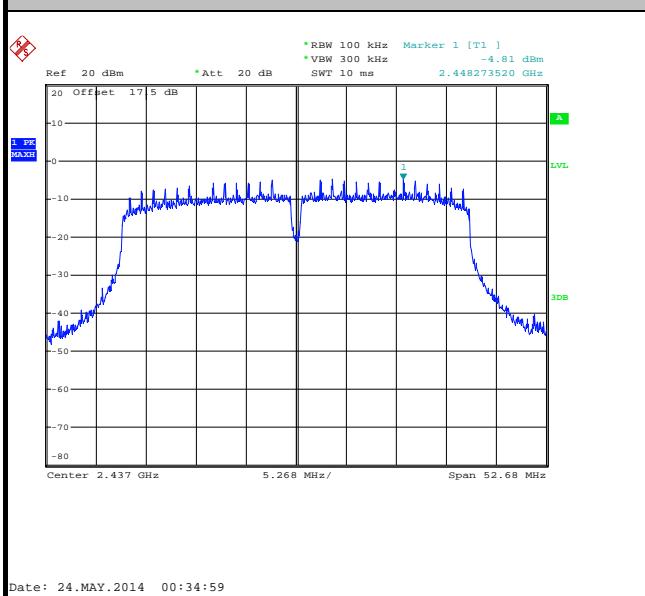

Mid Channel Plot

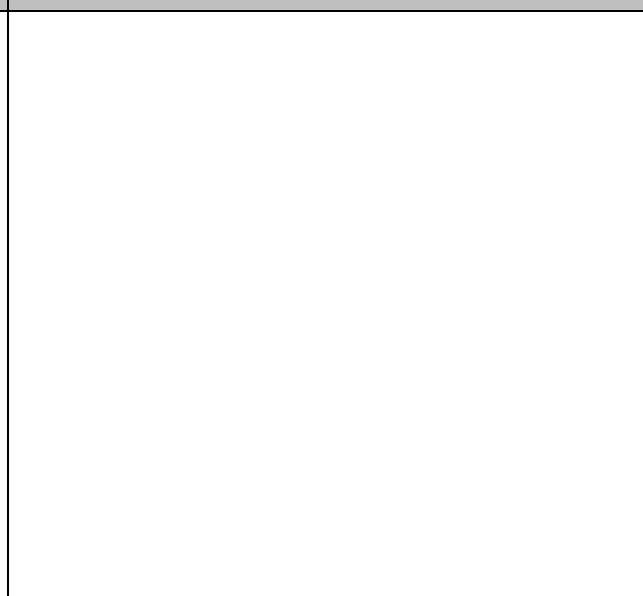

Spurious Emission 30MHz~3GHz

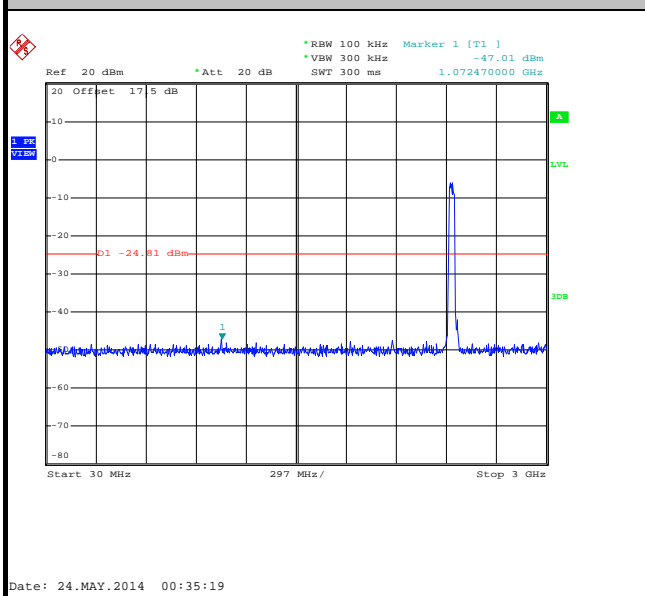

Spurious Emission 2GHz~25GHz

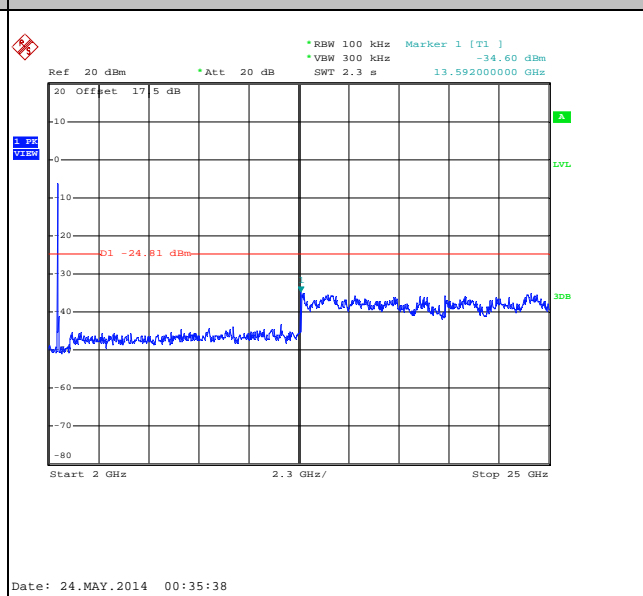



Test Mode :	802.11n HT40	Temperature :	24~26°C
Test Band :	2.4GHz High	Relative Humidity :	50~53%
Test Channel :	09	Test Engineer :	Blithe Li

WLAN 802.11n HT40 Channel 09

100kHz PSD reference Level

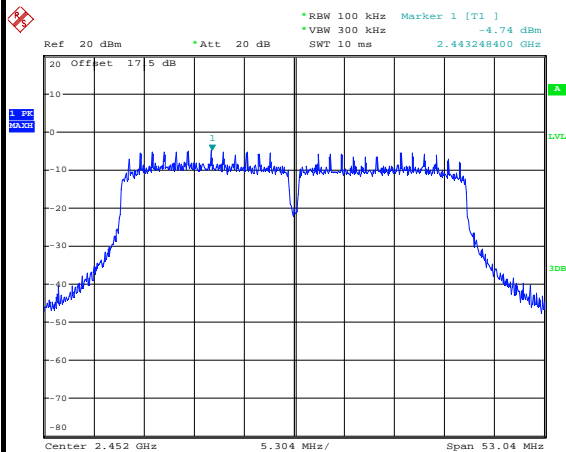

Date: 24.MAY.2014 00:39:26

High Channel Plot

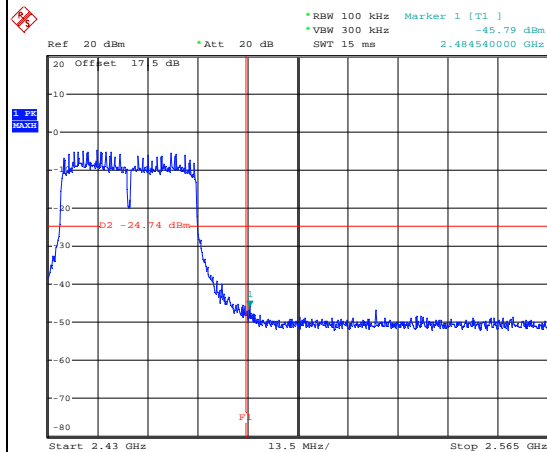

Date: 24.MAY.2014 00:39:40

Spurious Emission 30MHz~3GHz

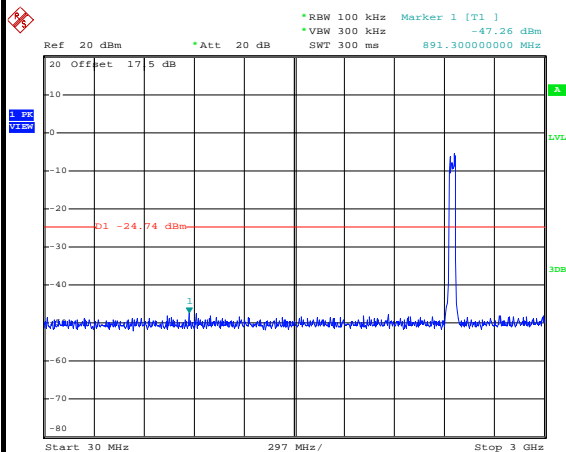

Date: 24.MAY.2014 00:42:34

Spurious Emission 2GHz~25GHz

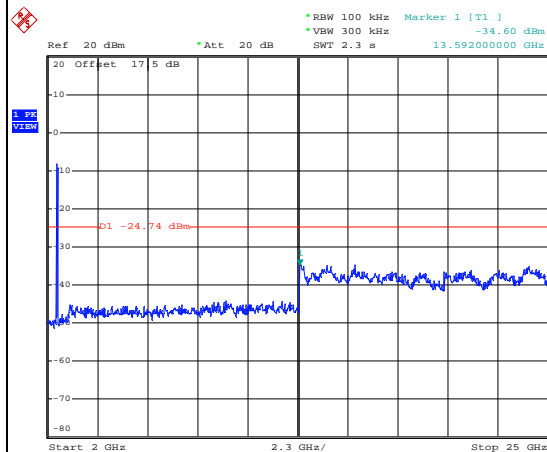

Date: 24.MAY.2014 00:42:53

3.5 Radiated Band Edges and Spurious Emission Measurement

3.5.1 Limit of Radiated band edge and Spurious Emission Measurement

In any 100 kHz bandwidth outside the intentional radiator frequency band, all harmonics/spurious must be at least 20 dB below the highest emission level within the authorized band. If the output power of this device was measured by spectrum analyzer, the attenuation under this paragraph shall be 30 dB instead of 20 dB. In addition, radiated emissions which fall in the restricted bands must also comply with the FCC section 15.209 limits as below.

Frequency (MHz)	Field Strength (microvolts/meter)	Measurement Distance (meters)
0.009 – 0.490	2400/F(kHz)	300
0.490 – 1.705	24000/F(kHz)	30
1.705 – 30.0	30	30
30 – 88	100	3
88 – 216	150	3
216 - 960	200	3
Above 960	500	3

3.5.2 Measuring Instruments

The measuring equipment is listed in the section 4 of this test report.

3.5.3 Test Procedures

1. The testing follows FCC KDB Publication No. 558074 D01 DTS Meas. Guidance v03r01.
2. The EUT was arranged to its worst case and then tune the antenna tower (from 1 m to 4 m) and turntable (from 0 degree to 360 degrees) to find the maximum reading. A pre-amp and a high pass filter are used for the test in order to get better signal level.
3. The EUT was placed on a turntable with 0.8 meter above ground.
4. The EUT was set 3 meters from the interference receiving antenna, which was mounted on the top of a variable height antenna tower.
5. Corrected Reading: Antenna Factor + Cable Loss + Read Level - Preamp Factor = Level
6. For measurement below 1GHz, If the emission level of the EUT measured by the peak detector is 3 dB lower than the applicable limit, the peak emission level will be reported. Otherwise, the emission measurement will be repeated using the quasi-peak detector and reported.
7. Use the following spectrum analyzer settings:
 - (1) Span shall wide enough to fully capture the emission being measured;
 - (2) Set RBW=100 kHz for $f < 1$ GHz; $VBW \geq RBW$; Sweep = auto; Detector function = peak; Trace = max hold;
 - (3) Set RBW = 1 MHz, VBW= 3MHz for $f \geq 1$ GHz for peak measurement.
 For average measurement:
 - $VBW = 10$ Hz, when duty cycle is no less than 98 percent.
 - $VBW \geq 1/T$, when duty cycle is less than 98 percent where T is the minimum transmission duration over which the transmitter is on and is transmitting at its maximum power control level for the tested mode of operation.

Band	Duty Cycle(%)	T(ms)	1/T(kHz)	VBW Setting
802.11b	97.62	8.20	0.12	300Hz
802.11g	86.77	1.36	0.73	1kHz
2.4GHz 802.11n HT20	85.79	1.28	0.78	1kHz
2.4GHz 802.11n HT40	75.71	0.64	1.57	3kHz

3.5.4 Test Setup

For radiated emissions below 30MHz

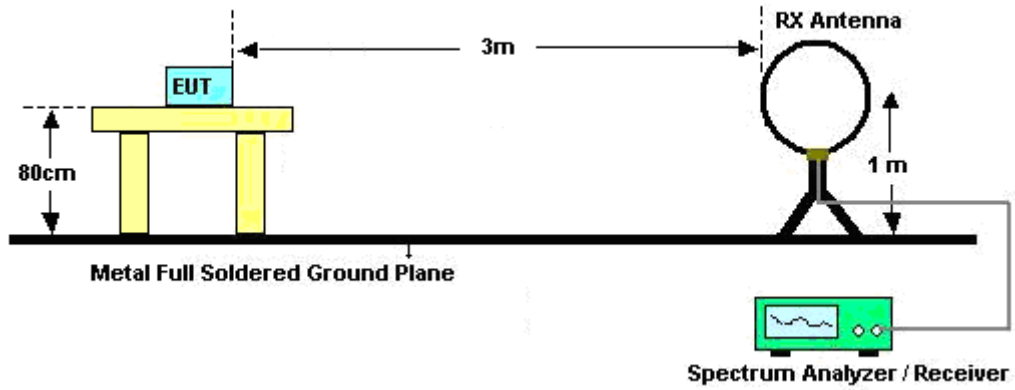

For radiated emissions from 30MHz to 1GHz

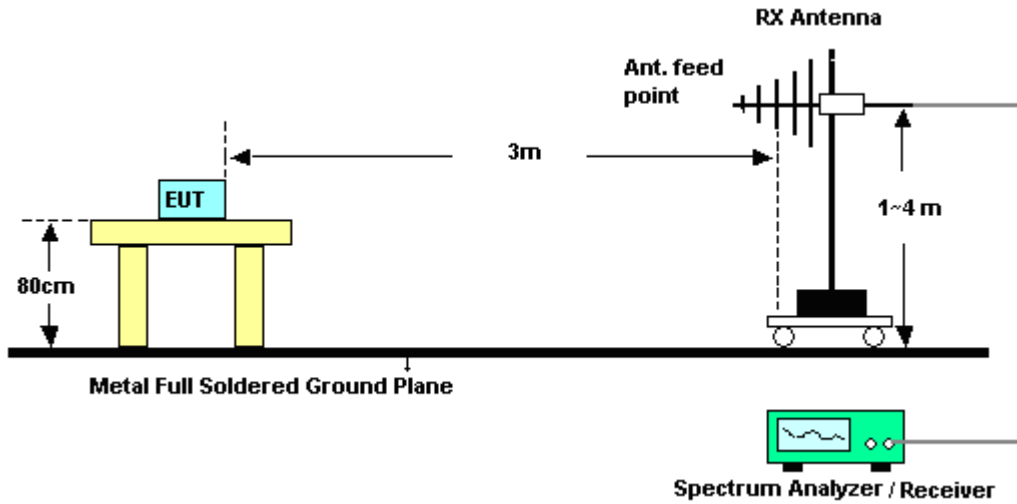

For radiated emissions above 1GHz

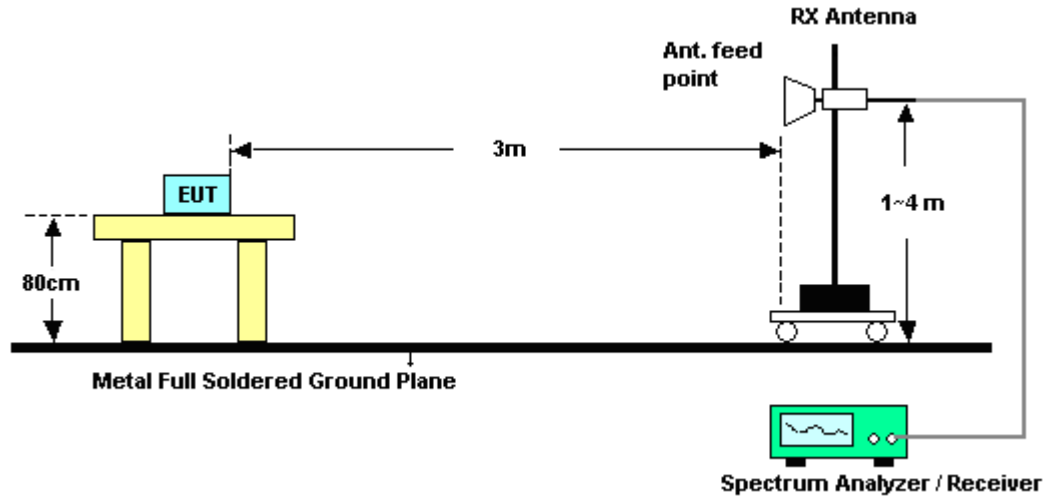

3.5.5 Test Results of Radiated Spurious Emissions (9kHz ~ 30MHz)

The low frequency, which started from 9 kHz to 30MHz, was pre-scanned and the result which was 20dB lower than the limit line per 15.31(o) was not reported.



3.5.6 Test Result of Radiated Spurious at Band Edges

Test Mode :	802.11b	Temperature :	24~25°C
Test Band :	Low	Relative Humidity :	48~49%
Test Channel :	01	Test Engineer :	Leo Liao

ANTENNA POLARITY : HORIZONTAL										
Frequency (MHz)	Level (dBμV/m)	Over Limit (dB)	Limit Line (dBμV/m)	Read Level (dBμV)	Antenna Factor (dB)	Cable Loss (dB)	Preamp Factor (dB)	Ant Pos (cm)	Table Pos (deg)	Remark
2389.83	46.32	-27.68	74	38.5	31.98	5.62	29.78	166	299	Peak
2360.76	34.85	-19.15	54	27.27	31.81	5.56	29.79	166	299	Average

ANTENNA POLARITY : VERTICAL										
Frequency (MHz)	Level (dBμV/m)	Over Limit (dB)	Limit Line (dBμV/m)	Read Level (dBμV)	Antenna Factor (dB)	Cable Loss (dB)	Preamp Factor (dB)	Ant Pos (cm)	Table Pos (deg)	Remark
2386.23	46.87	-27.13	74	39.09	31.98	5.59	29.79	123	254	Peak
2389.02	34.85	-19.15	54	27.07	31.98	5.59	29.79	123	254	Average

Test Mode :	802.11b	Temperature :	24~25°C
Test Band :	High	Relative Humidity :	48~49%
Test Channel :	11	Test Engineer :	Leo Liao

ANTENNA POLARITY : HORIZONTAL										
Frequency (MHz)	Level (dBμV/m)	Over Limit (dB)	Limit Line (dBμV/m)	Read Level (dBμV)	Antenna Factor (dB)	Cable Loss (dB)	Preamp Factor (dB)	Ant Pos (cm)	Table Pos (deg)	Remark
2483.65	51.94	-22.06	74	43.58	32.41	5.71	29.76	119	262	Peak
2483.65	43.62	-10.38	54	35.26	32.41	5.71	29.76	119	262	Average

ANTENNA POLARITY : VERTICAL										
Frequency (MHz)	Level (dBμV/m)	Over Limit (dB)	Limit Line (dBμV/m)	Read Level (dBμV)	Antenna Factor (dB)	Cable Loss (dB)	Preamp Factor (dB)	Ant Pos (cm)	Table Pos (deg)	Remark
2483.71	52	-22	74	43.64	32.41	5.71	29.76	118	260	Peak
2483.65	44	-10	54	35.64	32.41	5.71	29.76	118	260	Average



Test Mode :	802.11g	Temperature :	24~25°C
Test Band :	Low	Relative Humidity :	48~49%
Test Channel :	01	Test Engineer :	Leo Liao

ANTENNA POLARITY : HORIZONTAL										
Frequency (MHz)	Level (dBμV/m)	Over Limit (dB)	Limit Line (dBμV/m)	Read Level (dBμV)	Antenna Factor (dB)	Cable Loss (dB)	Preamp Factor (dB)	Ant Pos (cm)	Table Pos (deg)	Remark
2389.92	49.81	-24.19	74	41.99	31.98	5.62	29.78	109	85	Peak
2389.92	36.5	-17.5	54	28.68	31.98	5.62	29.78	109	85	Average

ANTENNA POLARITY : VERTICAL										
Frequency (MHz)	Level (dBμV/m)	Over Limit (dB)	Limit Line (dBμV/m)	Read Level (dBμV)	Antenna Factor (dB)	Cable Loss (dB)	Preamp Factor (dB)	Ant Pos (cm)	Table Pos (deg)	Remark
2389.65	49.42	-24.58	74	41.64	31.98	5.59	29.79	112	83	Peak
2389.92	36.98	-17.02	54	29.16	31.98	5.62	29.78	112	83	Average

Test Mode :	802.11g	Temperature :	24~25°C
Test Band :	High	Relative Humidity :	48~49%
Test Channel :	11	Test Engineer :	Leo Liao

ANTENNA POLARITY : HORIZONTAL										
Frequency (MHz)	Level (dBμV/m)	Over Limit (dB)	Limit Line (dBμV/m)	Read Level (dBμV)	Antenna Factor (dB)	Cable Loss (dB)	Preamp Factor (dB)	Ant Pos (cm)	Table Pos (deg)	Remark
2483.98	66.13	-7.87	74	57.77	32.41	5.71	29.76	100	132	Peak
2483.5	47.93	-6.07	54	39.57	32.41	5.71	29.76	100	132	Average

ANTENNA POLARITY : VERTICAL										
Frequency (MHz)	Level (dBμV/m)	Over Limit (dB)	Limit Line (dBμV/m)	Read Level (dBμV)	Antenna Factor (dB)	Cable Loss (dB)	Preamp Factor (dB)	Ant Pos (cm)	Table Pos (deg)	Remark
2483.5	65.17	-8.83	74	56.81	32.41	5.71	29.76	147	85	Peak
2483.5	45.78	-8.22	54	37.42	32.41	5.71	29.76	147	85	Average



Test Mode :	802.11n HT20	Temperature :	24~25°C
Test Band :	Low	Relative Humidity :	48~49%
Test Channel :	01	Test Engineer :	Leo Liao

ANTENNA POLARITY : HORIZONTAL										
Frequency (MHz)	Level (dBμV/m)	Over Limit (dB)	Limit Line (dBμV/m)	Read Level (dBμV)	Antenna Factor (dB)	Cable Loss (dB)	Preamp Factor (dB)	Ant Pos (cm)	Table Pos (deg)	Remark
2389.92	49.14	-24.86	74	41.32	31.98	5.62	29.78	100	143	Peak
2389.92	37.59	-16.41	54	29.77	31.98	5.62	29.78	100	143	Average

ANTENNA POLARITY : VERTICAL										
Frequency (MHz)	Level (dBμV/m)	Over Limit (dB)	Limit Line (dBμV/m)	Read Level (dBμV)	Antenna Factor (dB)	Cable Loss (dB)	Preamp Factor (dB)	Ant Pos (cm)	Table Pos (deg)	Remark
2389.74	49.07	-24.93	74	41.29	31.98	5.59	29.79	155	82	Peak
2389.92	36.8	-17.2	54	28.98	31.98	5.62	29.78	155	82	Average

Test Mode :	802.11n HT20	Temperature :	24~25°C
Test Band :	High	Relative Humidity :	48~49%
Test Channel :	11	Test Engineer :	Leo Liao

ANTENNA POLARITY : HORIZONTAL										
Frequency (MHz)	Level (dBμV/m)	Over Limit (dB)	Limit Line (dBμV/m)	Read Level (dBμV)	Antenna Factor (dB)	Cable Loss (dB)	Preamp Factor (dB)	Ant Pos (cm)	Table Pos (deg)	Remark
2483.53	65.97	-8.03	74	57.61	32.41	5.71	29.76	100	131	Peak
2483.5	47.68	-6.32	54	39.32	32.41	5.71	29.76	100	131	Average

ANTENNA POLARITY : VERTICAL										
Frequency (MHz)	Level (dBμV/m)	Over Limit (dB)	Limit Line (dBμV/m)	Read Level (dBμV)	Antenna Factor (dB)	Cable Loss (dB)	Preamp Factor (dB)	Ant Pos (cm)	Table Pos (deg)	Remark
2483.5	65.77	-8.23	74	57.41	32.41	5.71	29.76	185	87	Peak
2483.5	46.39	-7.61	54	38.03	32.41	5.71	29.76	185	87	Average



Test Mode :	802.11n HT40	Temperature :	24~25°C
Test Band :	Low	Relative Humidity :	48~49%
Test Channel :	03	Test Engineer :	Leo Liao

ANTENNA POLARITY : HORIZONTAL										
Frequency (MHz)	Level (dBμV/m)	Over Limit (dB)	Limit Line (dBμV/m)	Read Level (dBμV)	Antenna Factor (dB)	Cable Loss (dB)	Preamp Factor (dB)	Ant Pos (cm)	Table Pos (deg)	Remark
2390.01	57.83	-16.17	74	50.01	31.98	5.62	29.78	108	218	Peak
2388.93	43.34	-10.66	54	35.56	31.98	5.59	29.79	108	218	Average
2484.34	56.04	-17.96	74	47.68	32.41	5.71	29.76	108	218	Peak
2483.56	41.24	-12.76	54	32.88	32.41	5.71	29.76	108	218	Average

ANTENNA POLARITY : VERTICAL										
Frequency (MHz)	Level (dBμV/m)	Over Limit (dB)	Limit Line (dBμV/m)	Read Level (dBμV)	Antenna Factor (dB)	Cable Loss (dB)	Preamp Factor (dB)	Ant Pos (cm)	Table Pos (deg)	Remark
2390.01	57.14	-16.86	74	49.32	31.98	5.62	29.78	120	287	Peak
2389.02	42.7	-11.3	54	34.92	31.98	5.59	29.79	120	287	Average
2483.83	57.38	-16.62	74	49.02	32.41	5.71	29.76	120	287	Peak
2483.62	42.03	-11.97	54	33.67	32.41	5.71	29.76	120	287	Average



Test Mode :	802.11n HT40	Temperature :	24~25°C
Test Band :	High	Relative Humidity :	48~49%
Test Channel :	09	Test Engineer :	Leo Liao

ANTENNA POLARITY : HORIZONTAL										
Frequency (MHz)	Level (dBμV/m)	Over Limit (dB)	Limit Line (dBμV/m)	Read Level (dBμV)	Antenna Factor (dB)	Cable Loss (dB)	Preamp Factor (dB)	Ant Pos (cm)	Table Pos (deg)	Remark
2373	46.62	-27.38	74	38.92	31.9	5.59	29.79	108	220	Peak
2367.06	36.26	-17.74	54	28.65	31.81	5.59	29.79	108	220	Average
2485.54	61.14	-12.86	74	52.78	32.41	5.71	29.76	108	220	Peak
2483.89	47.6	-6.4	54	39.24	32.41	5.71	29.76	108	220	Average

ANTENNA POLARITY : VERTICAL										
Frequency (MHz)	Level (dBμV/m)	Over Limit (dB)	Limit Line (dBμV/m)	Read Level (dBμV)	Antenna Factor (dB)	Cable Loss (dB)	Preamp Factor (dB)	Ant Pos (cm)	Table Pos (deg)	Remark
2346.9	46.2	-27.8	74	38.71	31.72	5.56	29.79	121	260	Peak
2358.87	35.88	-18.12	54	28.3	31.81	5.56	29.79	121	260	Average
2486.11	62	-12	74	53.64	32.41	5.71	29.76	121	260	Peak
2483.56	48.78	-5.22	54	40.42	32.41	5.71	29.76	121	260	Average

3.5.7 Test Result of Radiated Spurious Emission (30MHz ~ 10th Harmonic)

Note: Pre-scanned all test modes and only choose the worst case mode recorded in the test report for radiated spurious emission below 1GHz.

Test Mode :	802.11b	Temperature :	24~25°C
Test Channel :	01	Relative Humidity :	48~49%
Test Engineer :	Leo Liao	Polarization :	Horizontal
Remark :	1. 2412 MHz is fundamental signal which can be ignored. 2. Average measurement was not performed if peak level went lower than the average limit.		

Frequency (MHz)	Level (dBμV/m)	Over Limit (dB)	Limit Line (dBμV/m)	Read Level (dBμV)	Antenna Factor (dB)	Cable Loss (dB)	Preamp Factor (dB)	Ant Pos (cm)	Table Pos (deg)	Remark
2412	105.96	-	-	98.05	32.07	5.62	29.78	166	299	Peak
2412	104.08	-	-	96.17	32.07	5.62	29.78	166	299	Average
4824	46.92	-27.08	74	62	33.82	8.36	57.26	105	198	Peak

Test Mode :	802.11b	Temperature :	24~25°C
Test Channel :	01	Relative Humidity :	48~49%
Test Engineer :	Leo Liao	Polarization :	Vertical
Remark :	1. 2412 MHz is fundamental signal which can be ignored. 2. Average measurement was not performed if peak level went lower than the average limit.		

Frequency (MHz)	Level (dBμV/m)	Over Limit (dB)	Limit Line (dBμV/m)	Read Level (dBμV)	Antenna Factor (dB)	Cable Loss (dB)	Preamp Factor (dB)	Ant Pos (cm)	Table Pos (deg)	Remark
2412	107.21	-	-	99.3	32.07	5.62	29.78	123	254	Peak
2412	105.24	-	-	97.33	32.07	5.62	29.78	123	254	Average
4824	47.39	-26.61	74	62.47	33.82	8.36	57.26	105	198	Peak



Test Mode :	802.11b	Temperature :	24~25°C
Test Channel :	06	Relative Humidity :	48~49%
Test Engineer :	Leo Liao	Polarization :	Horizontal
Remark :	1. 2437 MHz is fundamental signal which can be ignored. 2. Average measurement was not performed if peak level went lower than the average limit.		

Frequency (MHz)	Level (dBμV/m)	Over Limit (dB)	Limit Line (dBμV/m)	Read Level (dBμV)	Antenna Factor (dB)	Cable Loss (dB)	Preamp Factor (dB)	Ant Pos (cm)	Table Pos (deg)	Remark
2437	107.17	-	-	99.05	32.24	5.65	29.77	107	218	Peak
2437	105.28	-	-	97.16	32.24	5.65	29.77	107	218	Average
4874	46.94	-27.06	74	61.77	33.93	8.41	57.17	145	265	Peak
7311	39.89	-34.11	74	53.17	33.89	9.99	57.16	174	321	Peak

Test Mode :	802.11b	Temperature :	24~25°C
Test Channel :	06	Relative Humidity :	48~49%
Test Engineer :	Leo Liao	Polarization :	Vertical
Remark :	1. 2437 MHz is fundamental signal which can be ignored. 2. Average measurement was not performed if peak level went lower than the average limit.		

Frequency (MHz)	Level (dBμV/m)	Over Limit (dB)	Limit Line (dBμV/m)	Read Level (dBμV)	Antenna Factor (dB)	Cable Loss (dB)	Preamp Factor (dB)	Ant Pos (cm)	Table Pos (deg)	Remark
2437	107.95	-	-	99.83	32.24	5.65	29.77	119	258	Peak
2437	105.94	-	-	97.82	32.24	5.65	29.77	119	258	Average
4874	43.32	-30.68	74	58.15	33.93	8.41	57.17	145	265	Peak
7311	39.16	-34.84	74	52.44	33.89	9.99	57.16	174	321	Peak



Test Mode :	802.11b	Temperature :	24~25°C
Test Channel :	11	Relative Humidity :	48~49%
Test Engineer :	Leo Liao	Polarization :	Horizontal
Remark :	1. 2462 MHz is fundamental signal which can be ignored. 2. Average measurement was not performed if peak level went lower than the average limit.		

Frequency (MHz)	Level (dBμV/m)	Over Limit (dB)	Limit Line (dBμV/m)	Read Level (dBμV)	Antenna Factor (dB)	Cable Loss (dB)	Preamp Factor (dB)	Ant Pos (cm)	Table Pos (deg)	Remark
2462	108.35	-	-	100.1	32.33	5.68	29.76	119	262	Peak
2462	106.39	-	-	98.14	32.33	5.68	29.76	119	262	Average
4924	46.82	-27.18	74	61.39	34.05	8.46	57.08	146	347	Peak
7386	38.83	-35.17	74	51.92	33.94	10.02	57.05	145	274	Peak

Test Mode :	802.11b	Temperature :	24~25°C
Test Channel :	11	Relative Humidity :	48~49%
Test Engineer :	Leo Liao	Polarization :	Vertical
Remark :	1. 2462 MHz is fundamental signal which can be ignored. 2. Average measurement was not performed if peak level went lower than the average limit.		

Frequency (MHz)	Level (dBμV/m)	Over Limit (dB)	Limit Line (dBμV/m)	Read Level (dBμV)	Antenna Factor (dB)	Cable Loss (dB)	Preamp Factor (dB)	Ant Pos (cm)	Table Pos (deg)	Remark
2462	108.58	-	-	100.33	32.33	5.68	29.76	118	260	Peak
2462	106.64	-	-	98.39	32.33	5.68	29.76	118	260	Average
4924	46.49	-27.51	74	61.06	34.05	8.46	57.08	146	347	Peak
7386	39.34	-34.66	74	52.43	33.94	10.02	57.05	145	274	Peak



Test Mode :	802.11g	Temperature :	24~25°C
Test Channel :	01	Relative Humidity :	48~49%
Test Engineer :	Leo Liao	Polarization :	Horizontal
Remark :	1. 2412 MHz is fundamental signal which can be ignored. 2. Average measurement was not performed if peak level went lower than the average limit.		

Frequency (MHz)	Level (dBμV/m)	Over Limit (dB)	Limit Line (dBμV/m)	Read Level (dBμV)	Antenna Factor (dB)	Cable Loss (dB)	Preamp Factor (dB)	Ant Pos (cm)	Table Pos (deg)	Remark
2412	104.73	-	-	96.82	32.07	5.62	29.78	109	85	Peak
2412	96.1	-	-	88.19	32.07	5.62	29.78	109	85	Average
4824	36.85	-37.15	74	51.93	33.82	8.36	57.26	105	198	Peak

Test Mode :	802.11g	Temperature :	24~25°C
Test Channel :	01	Relative Humidity :	48~49%
Test Engineer :	Leo Liao	Polarization :	Vertical
Remark :	1. 2412 MHz is fundamental signal which can be ignored. 2. Average measurement was not performed if peak level went lower than the average limit.		

Frequency (MHz)	Level (dBμV/m)	Over Limit (dB)	Limit Line (dBμV/m)	Read Level (dBμV)	Antenna Factor (dB)	Cable Loss (dB)	Preamp Factor (dB)	Ant Pos (cm)	Table Pos (deg)	Remark
2412	105.37	-	-	97.46	32.07	5.62	29.78	112	83	Peak
2412	96.07	-	-	88.16	32.07	5.62	29.78	112	83	Average
4824	36.3	-37.7	74	51.38	33.82	8.36	57.26	105	198	Peak



Test Mode :	802.11g	Temperature :	24~25°C
Test Channel :	06	Relative Humidity :	48~49%
Test Engineer :	Leo Liao	Polarization :	Horizontal
Remark :	1. 2437 MHz is fundamental signal which can be ignored. 2. Average measurement was not performed if peak level went lower than the average limit.		

Frequency (MHz)	Level (dBμV/m)	Over Limit (dB)	Limit Line (dBμV/m)	Read Level (dBμV)	Antenna Factor (dB)	Cable Loss (dB)	Preamp Factor (dB)	Ant Pos (cm)	Table Pos (deg)	Remark
2437	106.09	-	-	97.97	32.24	5.65	29.77	100	129	Peak
2437	96.6	-	-	88.48	32.24	5.65	29.77	100	129	Average
4874	36.91	-37.09	74	51.74	33.93	8.41	57.17	145	265	Peak
7311	37.78	-36.22	74	51.06	33.89	9.99	57.16	174	321	Peak

Test Mode :	802.11g	Temperature :	24~25°C
Test Channel :	06	Relative Humidity :	48~49%
Test Engineer :	Leo Liao	Polarization :	Vertical
Remark :	1. 2437 MHz is fundamental signal which can be ignored. 2. Average measurement was not performed if peak level went lower than the average limit.		

Frequency (MHz)	Level (dBμV/m)	Over Limit (dB)	Limit Line (dBμV/m)	Read Level (dBμV)	Antenna Factor (dB)	Cable Loss (dB)	Preamp Factor (dB)	Ant Pos (cm)	Table Pos (deg)	Remark
2437	105.34	-	-	97.22	32.24	5.65	29.77	133	81	Peak
2437	96.09	-	-	87.97	32.24	5.65	29.77	133	81	Average
4874	36.11	-37.89	74	50.94	33.93	8.41	57.17	145	265	Peak
7311	36.74	-37.26	74	50.02	33.89	9.99	57.16	174	321	Peak



Test Mode :	802.11g	Temperature :	24~25°C
Test Channel :	11	Relative Humidity :	48~49%
Test Engineer :	Leo Liao	Polarization :	Horizontal
Remark :	1. 2462 MHz is fundamental signal which can be ignored. 2. Average measurement was not performed if peak level went lower than the average limit.		

Frequency (MHz)	Level (dBμV/m)	Over Limit (dB)	Limit Line (dBμV/m)	Read Level (dBμV)	Antenna Factor (dB)	Cable Loss (dB)	Preamp Factor (dB)	Ant Pos (cm)	Table Pos (deg)	Remark
2462	108.61	-	-	100.36	32.33	5.68	29.76	100	132	Peak
2462	99.07	-	-	90.82	32.33	5.68	29.76	100	132	Average
4924	40.12	-33.88	74	54.69	34.05	8.46	57.08	146	347	Peak
7386	36.8	-37.2	74	49.89	33.94	10.02	57.05	145	274	Peak

Test Mode :	802.11g	Temperature :	24~25°C
Test Channel :	11	Relative Humidity :	48~49%
Test Engineer :	Leo Liao	Polarization :	Vertical
Remark :	1. 2462 MHz is fundamental signal which can be ignored. 2. Average measurement was not performed if peak level went lower than the average limit.		

Frequency (MHz)	Level (dBμV/m)	Over Limit (dB)	Limit Line (dBμV/m)	Read Level (dBμV)	Antenna Factor (dB)	Cable Loss (dB)	Preamp Factor (dB)	Ant Pos (cm)	Table Pos (deg)	Remark
2462	107.98	-	-	99.73	32.33	5.68	29.76	147	85	Peak
2462	98.37	-	-	90.12	32.33	5.68	29.76	147	85	Average
4924	39.53	-34.47	74	54.1	34.05	8.46	57.08	146	347	Peak
7386	36.53	-37.47	74	49.62	33.94	10.02	57.05	145	274	Peak



Test Mode :	2.4GHz 802.11n HT20	Temperature :	24~25°C
Test Channel :	01	Relative Humidity :	48~49%
Test Engineer :	Leo Liao	Polarization :	Horizontal
Remark :	1. 2412 MHz is fundamental signal which can be ignored. 2. Average measurement was not performed if peak level went lower than the average limit.		

Frequency (MHz)	Level (dBμV/m)	Over Limit (dB)	Limit Line (dBμV/m)	Read Level (dBμV)	Antenna Factor (dB)	Cable Loss (dB)	Preamp Factor (dB)	Ant Pos (cm)	Table Pos (deg)	Remark
2412	103.16	-	-	95.25	32.07	5.62	29.78	100	143	Peak
2412	94.31	-	-	86.4	32.07	5.62	29.78	100	143	Average
4824	35.59	-38.41	74	50.67	33.82	8.36	57.26	105	198	Peak

Test Mode :	2.4GHz 802.11n HT20	Temperature :	24~25°C
Test Channel :	01	Relative Humidity :	48~49%
Test Engineer :	Leo Liao	Polarization :	Vertical
Remark :	1. 2412 MHz is fundamental signal which can be ignored. 2. Average measurement was not performed if peak level went lower than the average limit.		

Frequency (MHz)	Level (dBμV/m)	Over Limit (dB)	Limit Line (dBμV/m)	Read Level (dBμV)	Antenna Factor (dB)	Cable Loss (dB)	Preamp Factor (dB)	Ant Pos (cm)	Table Pos (deg)	Remark
2412	103.32	-	-	95.41	32.07	5.62	29.78	155	82	Peak
2412	94.03	-	-	86.12	32.07	5.62	29.78	155	82	Average
4824	37.39	-36.61	74	52.47	33.82	8.36	57.26	105	198	Peak



Test Mode :	2.4GHz 802.11n HT20	Temperature :	24~25°C
Test Channel :	06	Relative Humidity :	48~49%
Test Engineer :	Leo Liao	Polarization :	Horizontal
Remark :	1. 2437 MHz is fundamental signal which can be ignored. 2. Average measurement was not performed if peak level went lower than the average limit.		

Frequency (MHz)	Level (dBμV/m)	Over Limit (dB)	Limit Line (dBμV/m)	Read Level (dBμV)	Antenna Factor (dB)	Cable Loss (dB)	Preamp Factor (dB)	Ant Pos (cm)	Table Pos (deg)	Remark
2437	105.53	-	-	97.41	32.24	5.65	29.77	100	131	Peak
2437	95.69	-	-	87.57	32.24	5.65	29.77	100	131	Average
4874	36.69	-37.31	74	51.52	33.93	8.41	57.17	145	265	Peak
7311	37.17	-36.83	74	50.45	33.89	9.99	57.16	174	321	Peak

Test Mode :	2.4GHz 802.11n HT20	Temperature :	24~25°C
Test Channel :	06	Relative Humidity :	48~49%
Test Engineer :	Leo Liao	Polarization :	Vertical
Remark :	1. 2437 MHz is fundamental signal which can be ignored. 2. Average measurement was not performed if peak level went lower than the average limit.		

Frequency (MHz)	Level (dBμV/m)	Over Limit (dB)	Limit Line (dBμV/m)	Read Level (dBμV)	Antenna Factor (dB)	Cable Loss (dB)	Preamp Factor (dB)	Ant Pos (cm)	Table Pos (deg)	Remark
2437	104.19	-	-	96.07	32.24	5.65	29.77	147	83	Peak
2437	95.4	-	-	87.28	32.24	5.65	29.77	147	83	Average
4874	36.46	-37.54	74	51.29	33.93	8.41	57.17	145	265	Peak
7311	37.39	-36.61	74	50.67	33.89	9.99	57.16	174	321	Peak



Test Mode :	2.4GHz 802.11n HT20	Temperature :	24~25°C
Test Channel :	11	Relative Humidity :	48~49%
Test Engineer :	Leo Liao	Polarization :	Horizontal
Remark :	1. 2462 MHz is fundamental signal which can be ignored. 2. Average measurement was not performed if peak level went lower than the average limit.		

Frequency (MHz)	Level (dBμV/m)	Over Limit (dB)	Limit Line (dBμV/m)	Read Level (dBμV)	Antenna Factor (dB)	Cable Loss (dB)	Preamp Factor (dB)	Ant Pos (cm)	Table Pos (deg)	Remark
2462	106.5	-	-	98.25	32.33	5.68	29.76	100	131	Peak
2462	97.95	-	-	89.7	32.33	5.68	29.76	100	131	Average
4924	38.61	-35.39	74	53.18	34.05	8.46	57.08	146	347	Peak
7386	36.92	-37.08	74	50.01	33.94	10.02	57.05	145	274	Peak

Test Mode :	2.4GHz 802.11n HT20	Temperature :	24~25°C
Test Channel :	11	Relative Humidity :	48~49%
Test Engineer :	Leo Liao	Polarization :	Vertical
Remark :	1. 2462 MHz is fundamental signal which can be ignored. 2. Average measurement was not performed if peak level went lower than the average limit.		

Frequency (MHz)	Level (dBμV/m)	Over Limit (dB)	Limit Line (dBμV/m)	Read Level (dBμV)	Antenna Factor (dB)	Cable Loss (dB)	Preamp Factor (dB)	Ant Pos (cm)	Table Pos (deg)	Remark
2462	105.23	-	-	96.98	32.33	5.68	29.76	185	87	Peak
2462	96.9	-	-	88.65	32.33	5.68	29.76	185	87	Average
4924	38.85	-35.15	74	53.42	34.05	8.46	57.08	146	347	Peak
7386	36.41	-37.59	74	49.5	33.94	10.02	57.05	145	274	Peak



Test Mode :	2.4GHz 802.11n HT40	Temperature :	24~25°C
Test Channel :	03	Relative Humidity :	48~49%
Test Engineer :	Leo Liao	Polarization :	Horizontal
Remark :	1. 2422 MHz is fundamental signal which can be ignored. 2. Average measurement was not performed if peak level went lower than the average limit.		

Frequency (MHz)	Level (dBμV/m)	Over Limit (dB)	Limit Line (dBμV/m)	Read Level (dBμV)	Antenna Factor (dB)	Cable Loss (dB)	Preamp Factor (dB)	Ant Pos (cm)	Table Pos (deg)	Remark
2422	104.42	-	-	96.38	32.16	5.65	29.77	108	218	Peak
2422	96.28	-	-	88.24	32.16	5.65	29.77	108	218	Average
4844	37.04	-36.96	74	52.03	33.86	8.38	57.23	126	248	Peak
7266	36.82	-37.18	74	50.17	33.87	9.98	57.2	185	252	Peak

Test Mode :	2.4GHz 802.11n HT40	Temperature :	24~25°C
Test Channel :	03	Relative Humidity :	48~49%
Test Engineer :	Leo Liao	Polarization :	Vertical
Remark :	1. 2422 MHz is fundamental signal which can be ignored. 2. Average measurement was not performed if peak level went lower than the average limit.		

Frequency (MHz)	Level (dBμV/m)	Over Limit (dB)	Limit Line (dBμV/m)	Read Level (dBμV)	Antenna Factor (dB)	Cable Loss (dB)	Preamp Factor (dB)	Ant Pos (cm)	Table Pos (deg)	Remark
2422	104.03	-	-	95.99	32.16	5.65	29.77	120	287	Peak
2422	95.57	-	-	87.53	32.16	5.65	29.77	120	287	Average
4844	35.99	-38.01	74	50.98	33.86	8.38	57.23	126	248	Peak
7266	36.72	-37.28	74	50.07	33.87	9.98	57.2	185	252	Peak



Test Mode :	2.4GHz 802.11n HT40	Temperature :	24~25°C
Test Channel :	06	Relative Humidity :	48~49%
Test Engineer :	Leo Liao	Polarization :	Horizontal
Remark :	1. 2437 MHz is fundamental signal which can be ignored. 2. Average measurement was not performed if peak level went lower than the average limit.		

Frequency (MHz)	Level (dBμV/m)	Over Limit (dB)	Limit Line (dBμV/m)	Read Level (dBμV)	Antenna Factor (dB)	Cable Loss (dB)	Preamp Factor (dB)	Ant Pos (cm)	Table Pos (deg)	Remark
2437	105.25	-	-	97.13	32.24	5.65	29.77	120	255	Peak
2437	96.98	-	-	88.86	32.24	5.65	29.77	120	255	Average
4874	37.15	-36.85	74	51.98	33.93	8.41	57.17	132	224	Peak
7311	37.66	-36.34	74	50.94	33.89	9.99	57.16	119	347	Peak

Test Mode :	2.4GHz 802.11n HT40	Temperature :	24~25°C
Test Channel :	06	Relative Humidity :	48~49%
Test Engineer :	Leo Liao	Polarization :	Vertical
Remark :	1. 2437 MHz is fundamental signal which can be ignored. 2. Average measurement was not performed if peak level went lower than the average limit.		

Frequency (MHz)	Level (dBμV/m)	Over Limit (dB)	Limit Line (dBμV/m)	Read Level (dBμV)	Antenna Factor (dB)	Cable Loss (dB)	Preamp Factor (dB)	Ant Pos (cm)	Table Pos (deg)	Remark
2437	104.69	-	-	96.57	32.24	5.65	29.77	118	256	Peak
2437	97.05	-	-	88.93	32.24	5.65	29.77	118	256	Average
4874	35.28	-38.72	74	50.11	33.93	8.41	57.17	132	224	Peak
7311	36.3	-37.7	74	49.58	33.89	9.99	57.16	119	347	Peak



Test Mode :	2.4GHz 802.11n HT40	Temperature :	24~25°C
Test Channel :	09	Relative Humidity :	48~49%
Test Engineer :	Leo Liao	Polarization :	Horizontal
Remark :	1. 2452 MHz is fundamental signal which can be ignored. 2. Average measurement was not performed if peak level went lower than the average limit.		

Frequency (MHz)	Level (dBμV/m)	Over Limit (dB)	Limit Line (dBμV/m)	Read Level (dBμV)	Antenna Factor (dB)	Cable Loss (dB)	Preamp Factor (dB)	Ant Pos (cm)	Table Pos (deg)	Remark
81.41	30.26	-9.74	40	52.63	6.42	1.15	29.94	100	0	Peak
194.9	31.95	-11.55	43.5	51.32	8.9	1.67	29.94	-	-	Peak
312.27	35.61	-10.39	46	50.39	13.1	2.05	29.93	-	-	Peak
498.51	31.55	-14.45	46	41.91	17.04	2.52	29.92	-	-	Peak
799.21	31.07	-14.93	46	37.86	19.99	3.15	29.93	-	-	Peak
928.22	30.41	-15.59	46	35.92	21.04	3.39	29.94	-	-	Peak
2452	105.85	-	-	97.69	32.24	5.68	29.76	108	220	Peak
2452	96.97	-	-	88.81	32.24	5.68	29.76	108	220	Average
4904	37.94	-36.06	74	52.6	34.01	8.44	57.11	125	214	Peak
7356	37.21	-36.79	74	50.38	33.92	10.01	57.1	127	315	Peak



Test Mode :	2.4GHz 802.11n HT40	Temperature :	24~25°C
Test Channel :	09	Relative Humidity :	48~49%
Test Engineer :	Leo Liao	Polarization :	Vertical
Remark :	1. 2452 MHz is fundamental signal which can be ignored. 2. Average measurement was not performed if peak level went lower than the average limit.		

Frequency (MHz)	Level (dBμV/m)	Over Limit (dB)	Limit Line (dBμV/m)	Read Level (dBμV)	Antenna Factor (dB)	Cable Loss (dB)	Preamp Factor (dB)	Ant Pos (cm)	Table Pos (deg)	Remark
83.35	30.84	-9.16	40	52.56	7.06	1.16	29.94	200	0	Peak
193.93	31.45	-12.05	43.5	50.86	8.86	1.67	29.94	-	-	Peak
441.28	34.64	-11.36	46	46.35	15.82	2.39	29.92	-	-	Peak
608.12	28.88	-17.12	46	37.42	18.6	2.78	29.92	-	-	Peak
760.41	29.46	-16.54	46	36.51	19.8	3.08	29.93	-	-	Peak
896.21	28.68	-17.32	46	34.65	20.64	3.33	29.94	-	-	Peak
2452	105.42	-	-	97.26	32.24	5.68	29.76	121	260	Peak
2452	97.5	-	-	89.34	32.24	5.68	29.76	121	260	Average
4904	36	-38	74	50.66	34.01	8.44	57.11	125	214	Peak
7356	38.03	-35.97	74	51.2	33.92	10.01	57.1	127	315	Peak

3.6 AC Conducted Emission Measurement

3.6.1 Limit of AC Conducted Emission

For equipment that is designed to be connected to the public utility (AC) power line, the radio frequency voltage that is conducted back onto the AC power line on any frequency or frequencies within the band 150 kHz to 30 MHz shall not exceed the limits in the following table.

Frequency of Emission (MHz)	Conducted Limit (dB μ V)	
	Quasi-Peak	Average
0.15-0.5	66 to 56*	56 to 46*
0.5-5	56	46
5-30	60	50

*Decreases with the logarithm of the frequency.

3.6.2 Measuring Instruments

The measuring equipment is listed in the section 4 of this test report.

3.6.3 Test Procedures

1. The EUT was placed 0.4 meter from the conducting wall of the shielding room, and it was kept at least 80 centimeters from any other grounded conducting surface.
2. Connect EUT to the power mains through a line impedance stabilization network (LISN).
3. All the support units are connecting to the other LISN.
4. The LISN provides 50 ohm coupling impedance for the measuring instrument.
5. The FCC states that a 50 ohm, 50 microhenry LISN should be used.
6. Both sides of AC line were checked for maximum conducted interference.
7. The frequency range from 150 kHz to 30 MHz was searched.
8. Set the test-receiver system to Peak Detect Function and specified bandwidth with Maximum Hold Mode.

3.6.4 Test Setup

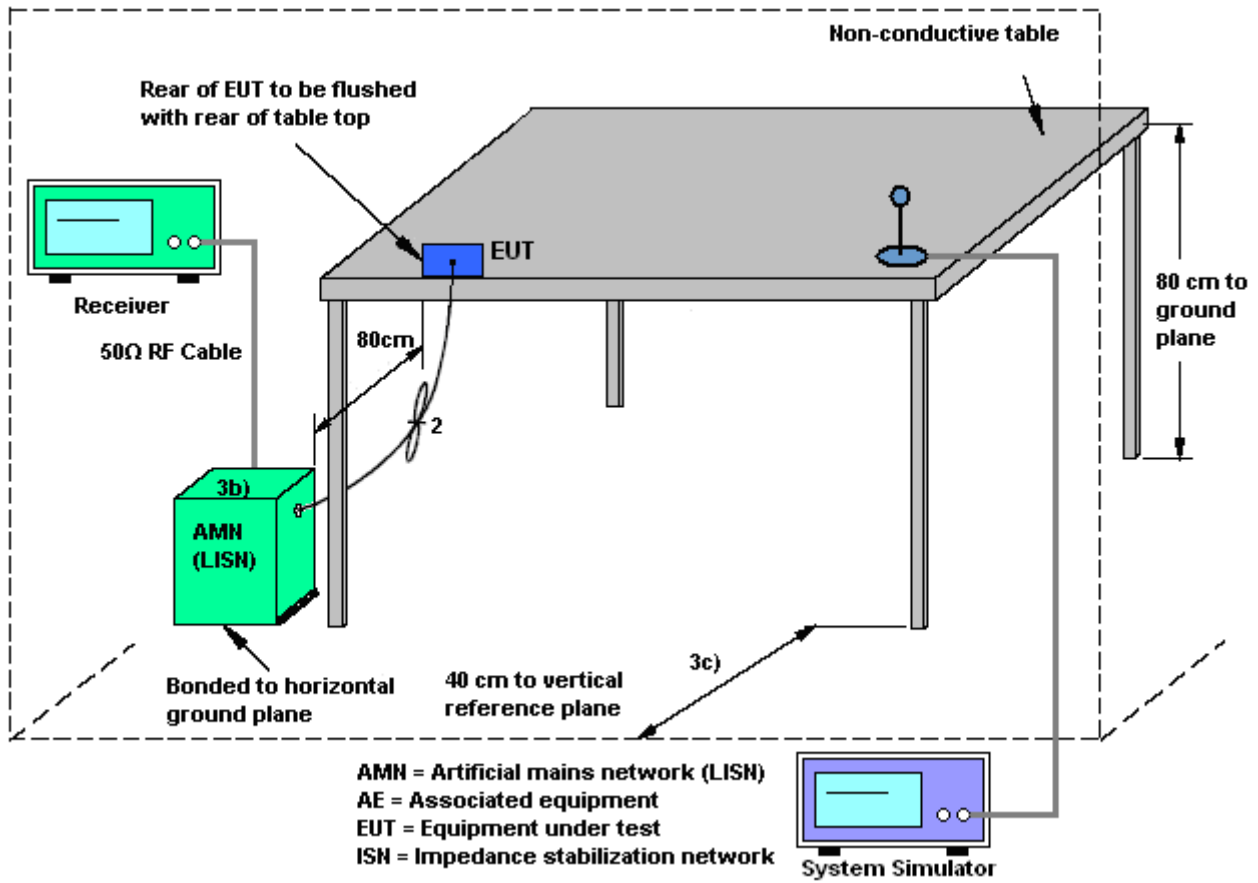



3.6.5 Test Result of AC Conducted Emission

Test Mode :	Mode 1	Temperature :	21~22°C
Test Engineer :	Jack Tian	Relative Humidity :	41~42%
Test Voltage :	120Vac / 60Hz	Phase :	Line
Function Type :	GSM850 Idle + Bluetooth Link + WLAN Link + USB Cable (Charging from Adapter) + Earphone		

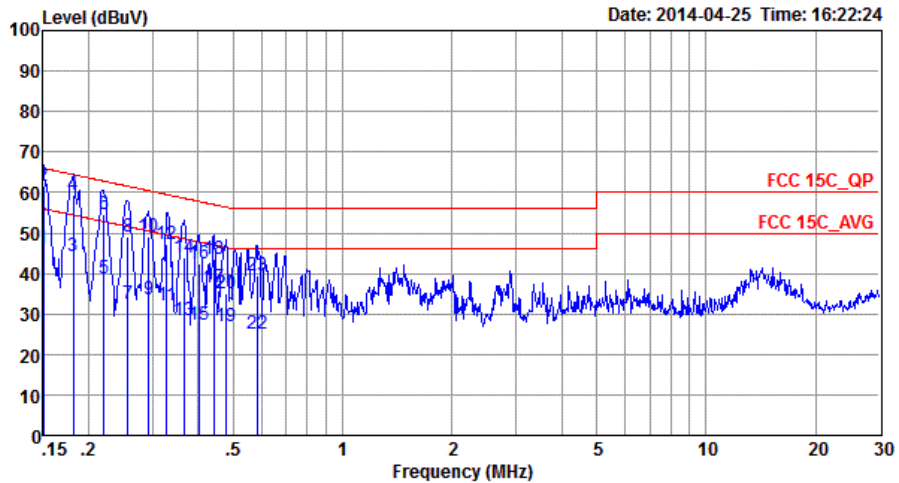

Site : CO01-SZ
 Condition: FCC 15C_QP LISN_L_20140304 LINE

	Freq	Level	Over Limit	Limit Line	Read Level	LISN Factor	Cable Loss	Remark
	MHz	dBuV	dB	dBuV	dBuV	dB	dB	
1	0.15	46.08	-9.92	56.00	35.50	0.22	10.36	Average
2 *	0.15	61.58	-4.42	66.00	51.00	0.22	10.36	QP
3	0.18	44.34	-10.08	54.42	33.80	0.22	10.32	Average
4	0.18	59.44	-4.98	64.42	48.90	0.22	10.32	QP
5	0.22	38.60	-14.19	52.79	28.10	0.23	10.27	Average
6	0.22	54.70	-8.09	62.79	44.20	0.23	10.27	QP
7	0.26	32.58	-18.98	51.56	22.10	0.24	10.24	Average
8	0.26	48.98	-12.58	61.56	38.50	0.24	10.24	QP
9	0.29	33.56	-16.90	50.46	23.10	0.25	10.21	Average
10	0.29	48.96	-11.50	60.46	38.50	0.25	10.21	QP
11	0.33	31.95	-17.54	49.49	21.50	0.26	10.19	Average
12	0.33	47.05	-12.44	59.49	36.60	0.26	10.19	QP
13	0.37	28.35	-20.21	48.56	17.90	0.27	10.18	Average
14	0.37	44.05	-14.51	58.56	33.60	0.27	10.18	QP
15	0.40	27.15	-20.62	47.77	16.70	0.28	10.17	Average
16	0.40	42.45	-15.32	57.77	32.00	0.28	10.17	QP
17	0.44	36.45	-10.57	47.02	26.00	0.29	10.16	Average
18	0.44	43.45	-13.57	57.02	33.00	0.29	10.16	QP
19	0.48	27.00	-19.41	46.41	16.54	0.30	10.16	Average
20	0.48	35.00	-21.41	56.41	24.54	0.30	10.16	QP
21	0.58	25.20	-20.80	46.00	14.80	0.25	10.15	Average
22	0.58	39.60	-16.40	56.00	29.20	0.25	10.15	QP



Test Mode :	Mode 1	Temperature :	21~22°C
Test Engineer :	Jack Tian	Relative Humidity :	41~42%
Test Voltage :	120Vac / 60Hz	Phase :	Neutral
Function Type :	GSM850 Idle + Bluetooth Link + WLAN Link + USB Cable (Charging from Adapter) + Earphone		

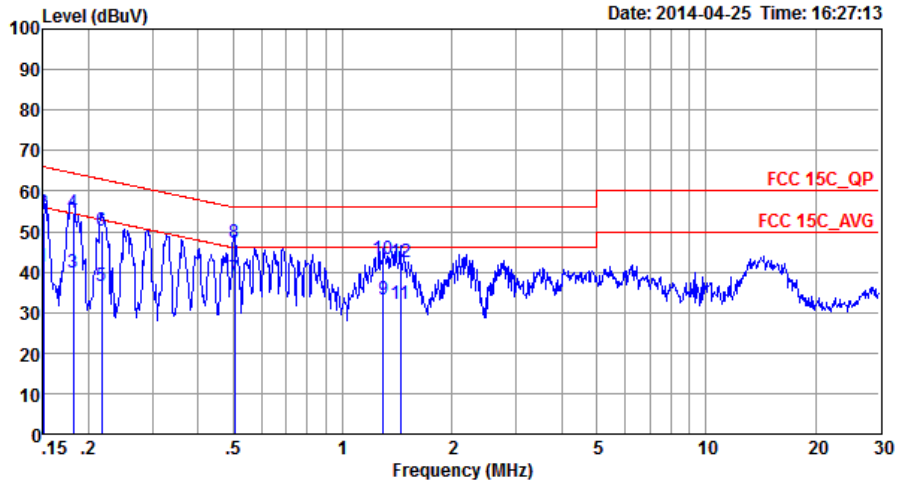

Site : C001-SZ
Condition: FCC 15C_QP LISN_N_20140304 NEUTRAL

	Freq	Level	Over Limit	Limit Line	Read Level	LISN Factor	Cable Loss	Remark
	MHz	dBuV	dB	dBuV	dBuV	dB	dB	
1	0.15	41.29	-14.71	56.00	30.60	0.33	10.36	Average
2	0.15	54.69	-11.31	66.00	44.00	0.33	10.36	QP
3	0.18	39.94	-14.48	54.42	29.30	0.32	10.32	Average
4	0.18	54.44	-9.98	64.42	43.80	0.32	10.32	QP
5	0.22	36.60	-16.32	52.92	26.00	0.33	10.27	Average
6	0.22	50.00	-12.92	62.92	39.40	0.33	10.27	QP
7 *	0.50	38.26	-7.74	46.00	27.69	0.41	10.16	Average
8	0.50	47.06	-8.94	56.00	36.49	0.41	10.16	QP
9	1.30	33.31	-12.69	46.00	22.80	0.35	10.16	Average
10	1.30	43.31	-12.69	56.00	32.80	0.35	10.16	QP
11	1.44	32.12	-13.88	46.00	21.60	0.35	10.17	Average
12	1.44	42.42	-13.58	56.00	31.90	0.35	10.17	QP



3.7 Antenna Requirements

3.7.1 Standard Applicable

If directional gain of transmitting antennas is greater than 6dBi, the power shall be reduced by the same level in dB comparing to gain minus 6dBi. For the fixed point-to-point operation, the power shall be reduced by one dB for every 3 dB that the directional gain of the antenna exceeds 6 dBi. The use of a permanently attached antenna or of an antenna that uses a unique coupling to the intentional radiator shall be considered sufficient to comply with the FCC rule.

3.7.2 Antenna Anti-Replacement Construction

An embedded-in antenna design is used.

3.7.3 Antenna Gain

The antenna peak gain of EUT is less than 6 dBi. Therefore, it is not necessary to reduce maximum peak output power limit.



4 List of Measuring Equipment

Instrument	Manufacturer	Model No.	Serial No.	Characteristics	Calibration Date	Test Date	Due Date	Remark
Spectrum Analyzer	R&S	FSP30	101400	9kHz~30GHz	Mar. 03, 2014	May 07, 2014~ May 29, 2014	Mar. 02, 2015	Conducted (TH01-SZ)
Power Meter	Anritsu	ML2495A	1218010	13dBm~-20dBm	Mar. 03, 2014	May 07, 2014~ May 29, 2014	Mar. 02, 2015	Conducted (TH01-SZ)
Power Sensor	Anritsu	MA2411B	1207253	0.3GHz~40GHz	Mar. 03, 2014	May 07, 2014~ May 29, 2014	Mar. 02, 2015	Conducted (TH01-SZ)
ESCIO TEST Receiver	R&S	ESCI	100724	9kHz~3GHz	Feb. 21, 2014	May 24, 2014	Feb. 20, 2015	Radiation (03CH01-SZ)
Signal Analyzer	R&S	FSV40	101078	10Hz~40GHz	Jun. 17, 2013	May 24, 2014	Jun. 16, 2014	Radiation (03CH01-SZ)
Loop Antenna	R&S	HFH2-Z2	100354	9kHz~30MHz	May 29, 2013	May 24, 2014	May 28, 2014	Radiation (03CH01-SZ)
Bilog Antenna	TESEQ	CBL 6112D	23188	30MHz~2GHz	Oct. 26, 2013	May 24, 2014	Oct. 25, 2014	Radiation (03CH01-SZ)
Double Ridge Horn Antenna	ETS Lindgren	3117	00119436	1GHz~18GHz	Oct. 26, 2013	May 24, 2014	Oct. 25, 2014	Radiation (03CH01-SZ)
Double Ridged Horn Antenna	COM-POWER	AH-840	101073	18GHz~40GHz	Jan. 27, 2014	May 24, 2014	Jan. 26, 2015	Radiation (03CH01-SZ)
Amplifier	ADVANTEST	BB525C	E9007003	9kHz~3000MHz	Feb. 21, 2014	May 24, 2014	Feb. 20, 2015	Radiation (03CH01-SZ)
Amplifier	Agilent	83017A	MY39501302	3Hz~26.5GHz	Mar. 03, 2014	May 24, 2014	Mar. 02, 2015	Radiation (03CH01-SZ)
AC Source(AVR)	Chroma	61601	616010001985	100Vac~250Vac	Mar. 25, 2014	May 24, 2014	Mar. 24, 2015	Radiation (03CH01-SZ)
Turn Table	EM Electronics	EM 1000	N/A	0~360 degree	NCR	May 24, 2014	NCR	Radiation (03CH01-SZ)
Antenna Mast	EM Electronics	EM 1000	N/A	1 m~4 m	NCR	May 24, 2014	NCR	Radiation (03CH01-SZ)
ESCIO TEST Receiver	R&S	ESCI	100724	9kHz~3GHz	Feb. 21, 2014	Apr. 25, 2014	Feb. 20, 2015	Conduction (CO01-SZ)
AC LISN	EMCO	3816/2SH	00103912	9kHz~30MHz	Mar. 04, 2014	Apr. 25, 2014	Mar. 03, 2015	Conduction (CO01-SZ)
AC LISN (for auxiliary equipment)	EMCO	3816/2SH	00103892	9kHz~30MHz	Mar. 04, 2014	Apr. 25, 2014	Mar. 03, 2015	Conduction (CO01-SZ)
AC Power Source	Chroma	61602	616020000891	100Vac~250Vac	Dec. 17, 2013	Apr. 25, 2014	Dec. 16, 2014	Conduction (CO01-SZ)



5 Uncertainty of Evaluation

Uncertainty of Conducted Emission Measurement (150 kHz ~ 30 MHz)

Measuring Uncertainty for a Level of Confidence of 95% ($U = 2Uc(y)$)	2.31
---	------

Uncertainty of Radiated Emission Measurement (30 MHz ~ 1000 MHz)

Measuring Uncertainty for a Level of Confidence of 95% ($U = 2Uc(y)$)	3.90
---	------