

FCC RF Test Report

APPLICANT : Brightstar Corporation
EQUIPMENT : Mobile phone
BRAND NAME : Avvio
MODEL NAME : Avvio L500
FCC ID : WVBAL500
STANDARD : 47 CFR Part 2, 27(L), 27(M)
CLASSIFICATION : PCS Licensed Transmitter Held to Ear (PCE)

The product was testing completed on May 21, 2014. We, SPORTON INTERNATIONAL (SHENZHEN) INC., would like to declare that the tested sample has been evaluated in accordance with the test procedures given in ANSI / TIA / EIA-603-C-2004 and the testing has shown the tested sample to be in compliance with the applicable technical standards. The test results in this report apply exclusively to the tested model / sample. Without written approval of SPORTON INTERNATIONAL (SHENZHEN) INC., the test report shall not be reproduced except in full.



Reviewed by: Joseph Lin / Supervisor

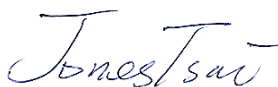

Approved by: Jones Tsai / Manager



SPORTON INTERNATIONAL (SHENZHEN) INC.

No. 3 Building, the third floor of south, Shahe River west, Fengzeyuan warehouse, Nanshan District, Shenzhen, Guangdong, P. R. C.



TABLE OF CONTENTS

REVISION HISTORY..... 3

SUMMARY OF TEST RESULT 4

1 GENERAL DESCRIPTION 5

 1.1 Applicant..... 5

 1.2 Manufacturer..... 5

 1.3 Product Feature of Equipment Under Test..... 5

 1.4 Product Specification subjective to this standard 5

 1.5 Modification of EUT 6

 1.6 Maximum EIRP Power, Frequency Tolerance, and Emission Designator 6

 1.7 Testing Location 7

 1.8 Applicable Standards..... 8

2 TEST CONFIGURATION OF EQUIPMENT UNDER TEST 9

 2.1 Test Mode..... 9

 2.2 Connection Diagram of Test System..... 10

 2.3 Support Unit used in test configuration and system 10

 2.4 Measurement Results Explanation Example..... 11

3 TEST RESULT..... 12

 3.1 Conducted Output Power Measurement 12

 3.2 Peak-to-Average Ratio 18

 3.3 Equivalent Isotropic Radiated Power Measurement 22

 3.4 99% Occupied Bandwidth and 26dB Bandwidth Measurement..... 29

 3.5 Conducted Band Edge Measurement 51

 3.6 Conducted Spurious Emission Measurement 93

 3.7 Radiated Spurious Emission Measurement 125

 3.8 Frequency Stability Measurement..... 148

4 LIST OF MEASURING EQUIPMENT 151

5 UNCERTAINTY OF EVALUATION 152

APPENDIX A. SETUP PHOTOGRAPHS

SUMMARY OF TEST RESULT

Report Section	FCC Rule	Description	Limit	Result	Remark
3.1	§2.1046	Conducted Output Power	Reporting Only	PASS	-
3.2	§27.50(d)(5)	Peak-to-Average Ratio	<13 dB	PASS	-
3.3	§27.50(d)(4)	Equivalent Isotropic Radiated Power (Band 4)	EIRP < 1Watt	PASS	-
	§27.50(h)(2)	Equivalent Isotropic Radiated Power (Band 7)	EIRP < 2Watt		
3.4	§2.1049 §27.53(g)(3) §27.53(l)(6)	99% Occupied Bandwidth and 26dB Bandwidth	Reporting Only	PASS	-
3.5	§2.1051 §27.53(g)	Conducted Band Edge Measurement (Band 4)	< 43+10log ₁₀ (P[Watt])	PASS	-
	§2.1051 §27.53(l)(4)	Conducted Band Edge Measurement (Band 7)	< 5.5MHz: -13 dBm ≥5.5MHz: -25 dBm		
3.6	§2.1051 §27.53(g)	Conducted Spurious Emission (Band 4)	< 43+10log ₁₀ (P[Watts])	PASS	-
	§2.1051 §27.53(l)(4)	Conducted Spurious Emission (Band 7)	< 55+10log ₁₀ (P[Watts])	PASS	-
3.7	§2.1053 §27.53(g)	Radiated Spurious Emission (Band 4)	< 43+10log ₁₀ (P[Watts])	PASS	Under limit 24.19 dB at 7710.000 MHz
	§2.1053 §27.53(l)(4)	Radiated Spurious Emission (Band 7)	< 55+10log ₁₀ (P[Watts])	PASS	
3.8	§2.1055 §27.54	Frequency Stability Temperature & Voltage	< 2.5 ppm	PASS	-



1 General Description

1.1 Applicant

Brightstar Corporation

9725 NW 117th Ave., Miami, Florida, FL 33178, United States

1.2 Manufacturer

YULONG COMPUTER TELECOMMUNICATION SCIENTIFIC(SHENZHEN) CO., LTD

Coolpad Information Harbor, 2nd Mengxi Road, High-Tech Industrial Park(North), NanShan District, ShenZhen, P. R. C.

1.3 Product Feature of Equipment Under Test

Product Feature	
Equipment	Mobile phone
Brand Name	Avvio
Model Name	Avvio L500
FCC ID	WVBA500
EUT supports Radios application	GSM/GPRS/EGPRS/WCDMA/HSPA/HSPA+(Downlink Only)/DC-HSDPA/LTE/WLAN 2.4GHz 802.11b/g/n HT20/HT40/Bluetooth v3.0 + EDR/Bluetooth v4.0 LE
HW Version	P1
SW Version	P1
EUT Stage	Identical Prototype

Remark: The above EUT's information was declared by manufacturer. Please refer to the specifications or user's manual for more detailed description.

1.4 Product Specification subjective to this standard

Product Specification subjective to this standard	
Tx Frequency	LTE Band 4 : 1710.7 MHz ~ 1754.3 MHz LTE Band 7 : 2502.5 MHz ~ 2567.5 MHz
Rx Frequency	LTE Band 4 : 2110.7 MHz ~ 2154.3 MHz LTE Band 7 : 2622.5MHz ~ 2687.5 MHz
Bandwidth	LTE Band 4 : 1.4MHz / 3MHz / 5MHz / 10MHz / 15MHz / 20MHz LTE Band 7 : 5MHz / 10MHz / 15MHz / 20MHz
Maximum Output Power to Antenna	LTE Band 4 : 23.55 dBm LTE Band 7 : 22.85 dBm
Antenna Type	PIFA Antenna
Type of Modulation	QPSK / 16QAM

1.5 Modification of EUT

No modifications are made to the EUT during all test items.

1.6 Maximum EIRP Power, Frequency Tolerance, and Emission Designator

FCC Rule	System	Type of Modulation	BW	Maximum EIRP (W)	Frequency Tolerance (% , Hz, ppm)	Emission Designator
Part 27L	LTE Band 4	QPSK	1.4MHz	0.31 W	-	1M10G7D
Part 27L	LTE Band 4	16QAM	1.4MHz	0.23 W	-	1M10D7W
Part 27L	LTE Band 4	QPSK	3MHz	0.32 W	-	2M73G7D
Part 27L	LTE Band 4	16QAM	3MHz	0.24 W	-	2M73D7W
Part 27L	LTE Band 4	QPSK	5MHz	0.33 W	-	4M50G7D
Part 27L	LTE Band 4	16QAM	5MHz	0.24 W	-	4M50D7W
Part 27L	LTE Band 4	QPSK	10MHz	0.31 W	0.0053 ppm	9M09G7D
Part 27L	LTE Band 4	16QAM	10MHz	0.24 W	-	9M01D7W
Part 27L	LTE Band 4	QPSK	15MHz	0.30 W	-	13M4G7D
Part 27L	LTE Band 4	16QAM	15MHz	0.23 W	-	13M4D7W
Part 27L	LTE Band 4	QPSK	20MHz	0.30 W	-	18M3G7D
Part 27L	LTE Band 4	16QAM	20MHz	0.23 W	-	18M3D7W
Part 27M	LTE Band 7	QPSK	5MHz	0.28 W	-	4M50G7D
Part 27M	LTE Band 7	16QAM	5MHz	0.28 W	-	4M50D7W
Part 27M	LTE Band 7	QPSK	10MHz	0.25 W	0.0069 ppm	9M07G7D
Part 27M	LTE Band 7	16QAM	10MHz	0.24 W	-	9M01D7W
Part 27M	LTE Band 7	QPSK	15MHz	0.29 W	-	13M5G7D
Part 27M	LTE Band 7	16QAM	15MHz	0.24 W	-	13M4D7W
Part 27M	LTE Band 7	QPSK	20MHz	0.30 W	-	18M3G7D
Part 27M	LTE Band 7	16QAM	20MHz	0.23 W	-	18M3D7W



1.7 Testing Location

Test Site	SPORTON INTERNATIONAL (SHENZHEN) INC.		
Test Site Location	No. 3 Building, the third floor of south, Shahe River west, Fengzeyuan warehouse, Nanshan District, Shenzhen, Guangdong, P. R. C. TEL: +86-755- 3320-2398		
Test Site No.	Sporton Site No.		FCC Registration No.
	TH01-SZ	03CH01-SZ	831040

Test Site	SPORTON INTERNATIONAL (SHENZHEN) INC.		
Test Site Location	No. 101, Complex Building C, Guanlong Village, Xili Town, Nanshan District, Shenzhen, Guangdong, P. R. C. TEL: +86-755-8637-9589 FAX: +86-755-8637-9595		
Test Site No.	Sporton Site No.		
	OTA01-SZ		

Note: The test site complies with ANSI C63.4 2003 requirement

1.8 Applicable Standards

According to the specifications of the manufacturer, the EUT must comply with the requirements of the following standards:

- ♦ 47 CFR Part 2, 27(L), 27(M)
- ♦ ANSI / TIA / EIA-603-C-2004
- ♦ FCC KDB 971168 D01 Power Meas. License Digital Systems v02r01

Remark:

1. All test items were verified and recorded according to the standards and without any deviation during the test.
2. This EUT has also been tested and complied with the requirements of FCC Part 15, Subpart B, recorded in a separate test report.



2 Test Configuration of Equipment Under Test

2.1 Test Mode

Antenna port conducted and radiated test items listed below are performed according to KDB 971168 D01 Power Meas. License Digital Systems v02r01 with maximum output power.

Radiated measurements are performed by rotating the EUT in three different orthogonal test planes to find the maximum emission (Y plane).

Test Items	Band	Bandwidth (MHz)						Modulation		RB #			Test Channel		
		1.4	3	5	10	15	20	QPSK	16QAM	1	Half	Full	L	M	H
Max. Output Power	4	v	v	v	v	v	v	v	v	v	v	v	v	v	v
	7	-	-	v	v	v	v	v	v	v	v	v	v	v	v
Peak-to-Average Ratio	4						v		v	v		v		v	
	7	-	-				v		v	v		v		v	
26dB and 99% Bandwidth	4	v	v	v	v	v	v	v	v			v		v	
	7	-	-	v	v	v	v	v	v			v		v	
Conducted Band Edge	4	v	v	v	v	v	v	v	v	v		v	v		v
	7	-	-	v	v	v	v	v	v	v		v	v		v
Conducted Spurious Emission	4	v	v	v	v	v	v	v	v	v			v	v	v
	7	-	-	v	v	v	v	v	v	v			v	v	v
Frequency Stability	4				v			v				v		v	
	7	-	-		v			v				v		v	
E.R.P./ E.I.R.P.	4	v	v	v	v	v	v	v	v	v			v	v	v
	7	-	-	v	v	v	v	v	v	v			v	v	v
Radiated Spurious Emission	4	v	v	v	v	v	v	v		v				v	
	7	-	-	v	v	v	v	v		v				v	
Note	<ol style="list-style-type: none"> The mark "v" means that this configuration is chosen for testing. The mark "-" means that this bandwidth is not supported. The device is investigated from 30MHz to 10 times of fundamental signal for radiated spurious emission test under different RB size/offset and modulations in exploratory test. Subsequently, only the worst case emissions are reported. 														

2.4 Measurement Results Explanation Example

For all conducted test items:

The offset level is set in the spectrum analyzer to compensate the RF cable loss and attenuator factor between EUT conducted output port and spectrum analyzer. With the offset compensation, the spectrum analyzer reading level is exactly the EUT RF output level.

Example:

The spectrum analyzer offset is derived from RF cable loss and attenuator factor.

Offset = RF cable loss + attenuator factor.

Following shows an offset computation example with cable loss 7.5 dB and 10dB attenuator.

$$\begin{aligned}\text{Offset (dB)} &= \text{RF cable loss (dB)} + \text{attenuator factor (dB)} \\ &= 7.5 + 10 = 17.5 \text{ (dB)}\end{aligned}$$

3 Test Result

3.1 Conducted Output Power Measurement

3.1.1 Description of the Conducted Output Power Measurement

A system simulator was used to establish communication with the EUT. Its parameters were set to force the EUT transmitting at maximum output power. The measured power in the radio frequency on the transmitter output terminals shall be reported.

3.1.2 Measuring Instruments

The measuring equipment is listed in the section 4 of this test report.

3.1.3 Test Procedures

1. The transmitter output port was connected to the system simulator.
2. Set EUT at maximum power through the system simulator.
3. Select lowest, middle, and highest channels for each band and different modulation.
4. Measure and record the power level from the system simulator.

3.1.4 Test Setup

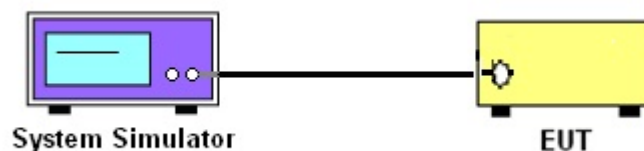



3.1.5 Test Result of Conducted Output Power

<LTE Band 4 Conducted Power>

BW [MHz]	Modulation	RB Size	RB Offset	Power (dBm) Low Ch. / Freq.	Power (dBm) Middle Ch. / Freq.	Power (dBm) High Ch. / Freq.
Channel				20050	20175	20300
Frequency (MHz)				1720	1732.5	1745
20	QPSK	1	0	23.24	23.34	23.55
20	QPSK	1	49	23.08	23.36	23.46
20	QPSK	1	99	23.12	23.29	23.50
20	QPSK	50	0	22.17	22.33	22.50
20	QPSK	50	24	22.15	22.26	22.48
20	QPSK	50	49	22.15	22.32	22.46
20	QPSK	100	0	22.10	22.28	22.43
20	16QAM	1	0	22.50	22.82	22.58
20	16QAM	1	49	22.21	22.83	22.64
20	16QAM	1	99	22.30	22.50	22.59
20	16QAM	50	0	21.17	21.18	21.36
20	16QAM	50	24	21.12	21.21	21.38
20	16QAM	50	49	21.11	21.19	21.36
20	16QAM	100	0	21.09	21.20	21.42
Channel				20025	20175	20325
Frequency (MHz)				1717.5	1732.5	1747.5
15	QPSK	1	0	23.16	23.30	23.49
15	QPSK	1	37	23.06	23.26	23.44
15	QPSK	1	74	23.10	23.32	23.48
15	QPSK	36	0	22.18	22.32	22.41
15	QPSK	36	18	22.16	22.36	22.45
15	QPSK	36	37	22.03	22.26	22.42
15	QPSK	75	0	22.05	22.24	22.46
15	16QAM	1	0	22.01	22.70	22.80
15	16QAM	1	37	22.05	22.65	22.84
15	16QAM	1	74	22.00	22.68	22.55
15	16QAM	36	0	21.17	21.18	21.47
15	16QAM	36	18	21.10	21.16	21.34
15	16QAM	36	37	20.95	21.26	21.36
15	16QAM	75	0	21.09	21.21	21.35



BW [MHz]	Modulation	RB Size	RB Offset	Power (dBm) Low Ch. / Freq.	Power (dBm) Middle Ch. / Freq.	Power (dBm) High Ch. / Freq.
Channel				20000	20175	20350
Frequency (MHz)				1715	1732.5	1750
10	QPSK	1	0	23.19	23.32	23.41
10	QPSK	1	24	23.10	23.22	23.48
10	QPSK	1	49	23.00	23.30	23.45
10	QPSK	25	0	22.25	22.28	22.45
10	QPSK	25	12	22.10	22.22	22.46
10	QPSK	25	24	22.07	22.31	22.31
10	QPSK	50	0	22.01	22.29	22.41
10	16QAM	1	0	21.97	22.40	22.43
10	16QAM	1	24	21.99	22.20	22.45
10	16QAM	1	49	21.89	22.42	22.32
10	16QAM	25	0	21.00	21.24	21.50
10	16QAM	25	12	21.12	21.24	21.42
10	16QAM	25	24	21.02	21.30	21.43
10	16QAM	50	0	21.01	21.16	21.44
Channel				19975	20175	20375
Frequency (MHz)				1712.5	1732.5	1752.5
5	QPSK	1	0	23.04	23.30	23.44
5	QPSK	1	12	23.02	23.26	23.48
5	QPSK	1	24	23.06	23.13	23.49
5	QPSK	12	0	22.17	22.28	22.57
5	QPSK	12	6	22.00	22.20	22.37
5	QPSK	12	11	21.95	22.35	22.29
5	QPSK	25	0	21.91	22.29	22.51
5	16QAM	1	0	22.06	22.21	22.76
5	16QAM	1	12	22.04	22.20	22.54
5	16QAM	1	24	22.02	22.23	22.35
5	16QAM	12	0	21.06	21.36	21.39
5	16QAM	12	6	21.01	21.17	21.40
5	16QAM	12	11	20.94	21.19	21.35
5	16QAM	25	0	20.96	21.30	21.36



BW [MHz]	Modulation	RB Size	RB Offset	Power (dBm) Low Ch. / Freq.	Power (dBm) Middle Ch. / Freq.	Power (dBm) High Ch. / Freq.
Channel				19965	20175	20385
Frequency (MHz)				1711.5	1732.5	1753.5
3	QPSK	1	0	23.09	23.29	23.32
3	QPSK	1	7	23.11	23.17	23.26
3	QPSK	1	14	22.94	23.14	23.30
3	QPSK	8	0	21.98	22.26	22.46
3	QPSK	8	4	22.03	22.18	22.39
3	QPSK	8	7	21.99	22.23	22.41
3	QPSK	15	0	21.98	22.23	22.42
3	16QAM	1	0	21.85	22.07	22.11
3	16QAM	1	7	21.84	22.13	22.15
3	16QAM	1	14	21.80	22.10	22.13
3	16QAM	8	0	20.96	21.07	21.30
3	16QAM	8	4	20.90	21.23	21.22
3	16QAM	8	7	20.88	21.16	21.28
3	16QAM	15	0	21.01	21.19	21.27
Channel				19957	20175	20393
Frequency (MHz)				1710.7	1732.5	1754.3
1.4	QPSK	1	0	22.95	23.26	23.46
1.4	QPSK	1	2	22.93	23.11	23.38
1.4	QPSK	1	5	22.94	23.24	23.39
1.4	QPSK	3	0	22.96	23.22	23.40
1.4	QPSK	3	1	22.86	23.27	23.43
1.4	QPSK	3	2	22.87	23.25	23.40
1.4	QPSK	6	0	22.09	22.27	22.46
1.4	16QAM	1	0	21.92	22.36	22.28
1.4	16QAM	1	2	21.82	22.11	22.22
1.4	16QAM	1	5	21.95	22.18	22.35
1.4	16QAM	3	0	21.86	22.29	22.33
1.4	16QAM	3	1	21.83	22.39	22.26
1.4	16QAM	3	2	21.80	22.16	22.30
1.4	16QAM	6	0	21.05	21.18	21.36



<LTE Band 7 Conducted Power>

BW [MHz]	Modulation	RB Size	RB Offset	Power (dBm) Low Ch. / Freq.	Power (dBm) Middle Ch. / Freq.	Power (dBm) High Ch. / Freq.
Channel				20850	21100	21350
Frequency (MHz)				2510	2535	2560
20	QPSK	1	0	22.43	22.65	22.66
20	QPSK	1	49	22.20	22.85	22.69
20	QPSK	1	99	22.36	22.75	22.57
20	QPSK	50	0	21.06	21.63	21.70
20	QPSK	50	24	21.09	21.72	21.76
20	QPSK	50	49	21.21	21.78	21.77
20	QPSK	100	0	21.30	21.68	21.63
20	16QAM	1	0	21.50	21.85	21.97
20	16QAM	1	49	21.45	21.77	21.96
20	16QAM	1	99	21.54	21.80	21.99
20	16QAM	50	0	20.07	20.66	20.67
20	16QAM	50	24	20.06	20.78	20.69
20	16QAM	50	49	20.22	20.82	20.60
20	16QAM	100	0	20.15	20.78	20.61
Channel				20825	21100	21375
Frequency (MHz)				2507.5	2535	2562.5
15	QPSK	1	0	22.19	22.68	22.76
15	QPSK	1	37	22.16	22.57	22.72
15	QPSK	1	74	22.08	22.78	22.78
15	QPSK	36	0	21.11	21.60	21.78
15	QPSK	36	18	21.12	21.73	21.76
15	QPSK	36	37	21.23	21.80	21.76
15	QPSK	75	0	21.15	21.30	21.73
15	16QAM	1	0	21.59	21.82	21.98
15	16QAM	1	37	21.63	21.83	21.69
15	16QAM	1	74	21.58	21.87	21.95
15	16QAM	36	0	19.88	20.68	20.63
15	16QAM	36	18	20.00	20.73	20.68
15	16QAM	36	37	20.08	20.79	20.71
15	16QAM	75	0	20.13	20.75	20.60



BW [MHz]	Modulation	RB Size	RB Offset	Power (dBm) Low Ch. / Freq.	Power (dBm) Middle Ch. / Freq.	Power (dBm) High Ch. / Freq.
Channel				20800	21100	21400
Frequency (MHz)				2505	2535	2565
10	QPSK	1	0	22.00	22.79	22.73
10	QPSK	1	24	21.95	22.76	22.81
10	QPSK	1	49	21.99	22.70	22.62
10	QPSK	25	0	21.03	21.66	21.76
10	QPSK	25	12	20.99	21.71	21.83
10	QPSK	25	24	20.94	21.78	21.69
10	QPSK	50	0	20.88	21.71	21.59
10	16QAM	1	0	21.03	21.75	21.91
10	16QAM	1	24	21.07	21.66	21.86
10	16QAM	1	49	21.00	21.79	21.73
10	16QAM	25	0	19.94	20.74	20.57
10	16QAM	25	12	19.93	20.72	20.74
10	16QAM	25	24	19.90	20.82	20.66
10	16QAM	50	0	19.98	20.76	20.62
Channel				20775	21100	21425
Frequency (MHz)				2502.5	2535	2567.5
5	QPSK	1	0	22.00	22.67	22.78
5	QPSK	1	12	21.94	22.71	22.70
5	QPSK	1	24	21.98	22.68	22.79
5	QPSK	12	0	20.87	21.70	21.87
5	QPSK	12	6	21.02	21.72	21.72
5	QPSK	12	11	20.97	21.74	21.61
5	QPSK	25	0	20.93	21.76	21.74
5	16QAM	1	0	20.97	21.70	21.89
5	16QAM	1	12	20.90	21.65	21.80
5	16QAM	1	24	20.95	21.60	21.83
5	16QAM	12	0	19.85	20.65	20.79
5	16QAM	12	6	19.98	20.63	20.59
5	16QAM	12	11	19.91	20.66	20.58
5	16QAM	25	0	19.82	20.82	20.62

Note: Maximum average power for LTE.

3.2 Peak-to-Average Ratio

3.2.1 Description of the PAR Measurement

Power Complementary Cumulative Distribution Function (CCDF) curves provide a means for characterizing the power peaks of a digitally modulated signal on a statistical basis. A CCDF curve depicts the probability of the peak signal amplitude exceeding the average power level. Most contemporary measurement instrumentation include the capability to produce CCDF curves for an input signal provided that the instrument's resolution bandwidth can be set wide enough to accommodate the entire input signal bandwidth. In measuring transmissions in this band using an average power technique, the peak-to-average ratio (PAR) of the transmission may not exceed 13 dB.

3.2.2 Measuring Instruments

The measuring equipment is listed in the section 4 of this test report.

3.2.3 Test Procedures

1. The EUT was connected to spectrum and system simulator via a power divider.
2. Set the CCDF (Complementary Cumulative Distribution Function) option in spectrum analyzer.
3. The highest RF powers were measured and recorded the maximum PAPR level associated with a probability of 0.1 %.
4. Record the deviation as Peak to Average Ratio.

3.2.4 Test Setup

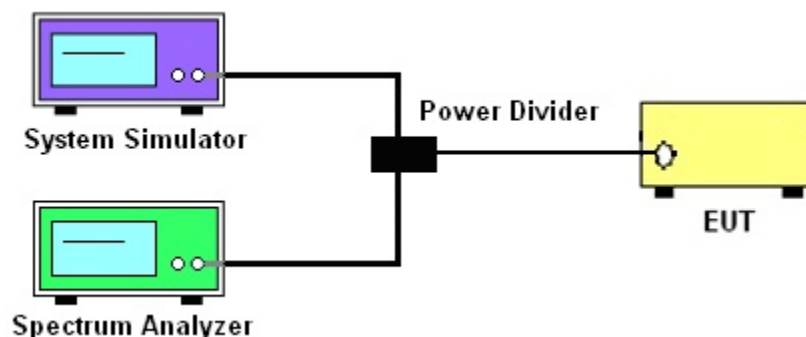



3.2.5 Test Result of Peak-to-Average Ratio

LTE Band 4				
BW [MHz]	Modulation	RB Size	RB Offset	Power (dBm) Middle Ch. / Freq.
Channel				20175
Frequency (MHz)				1732.5
20	16QAM	1	0	5.65
20	16QAM	100	0	5.74

LTE Band 7				
BW [MHz]	Modulation	RB Size	RB Offset	Power (dBm) Middle Ch. / Freq.
Channel				21100
Frequency (MHz)				2535
20	16QAM	1	0	5.65
20	16QAM	100	0	6.06



3.2.6 Peak to Average Power Ratio

Peak-to-Average Ratio on LTE Band 4 20MHz / 16QAM in Ch. 20175 (1RB Size)

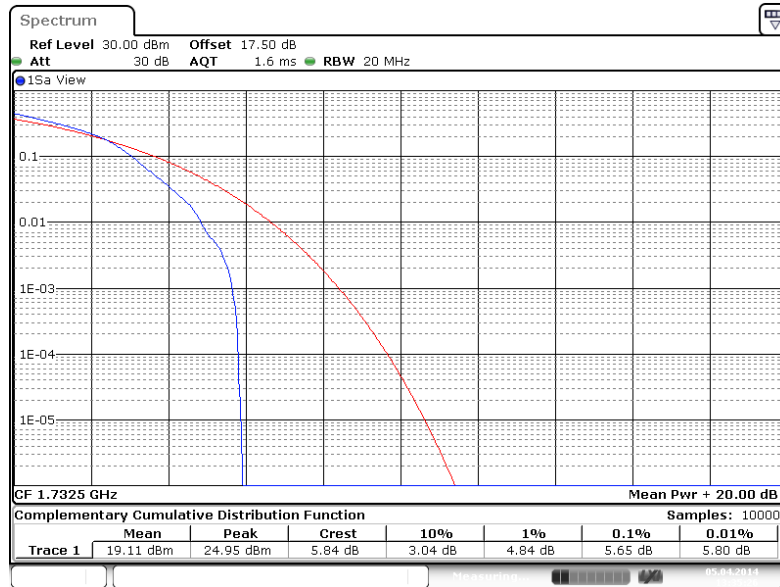

Date: 5.APR.2014 13:35:27

Peak-to-Average Ratio on LTE Band 4 20MHz / 16QAM in Ch. 20175 (100RB Size)

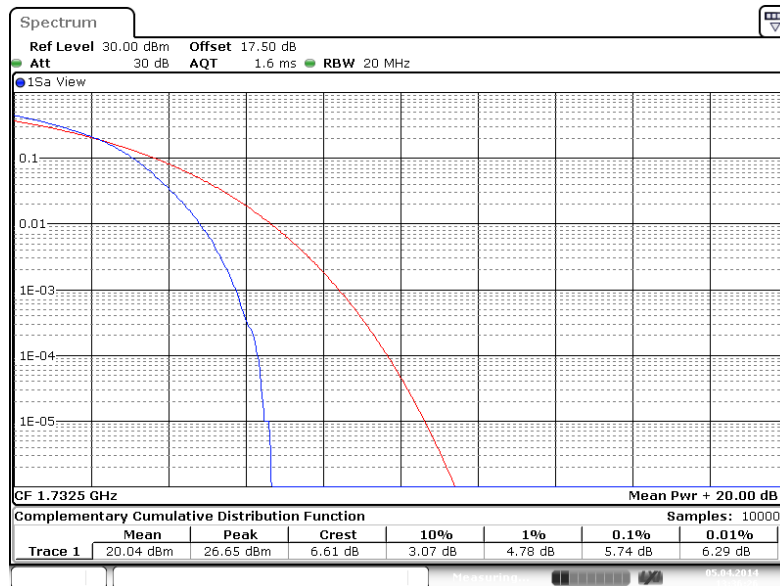

Date: 5.APR.2014 13:36:27



Peak-to-Average Ratio on LTE Band 7
20MHz / 16QAM in Ch. 21100 (1RB Size)

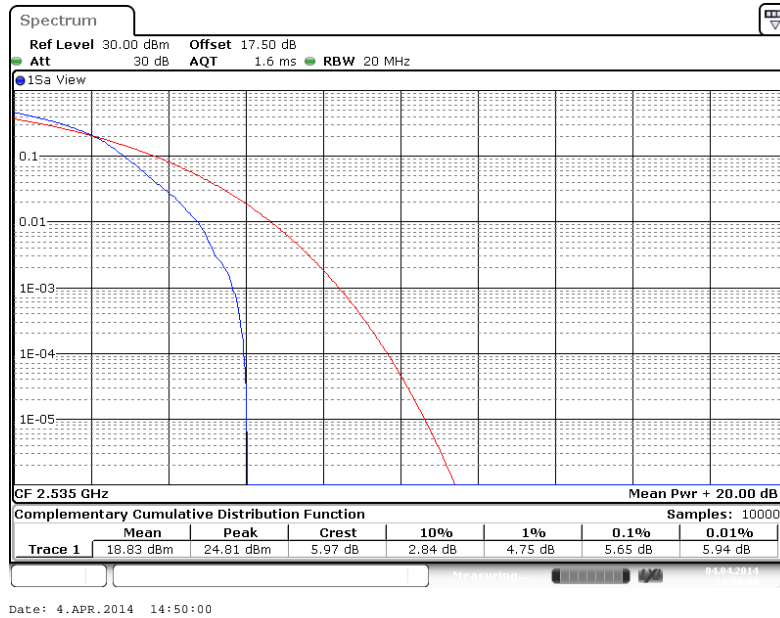

Peak-to-Average Ratio on LTE Band 7
20MHz / 16QAM in Ch. 21100 (100RB Size)

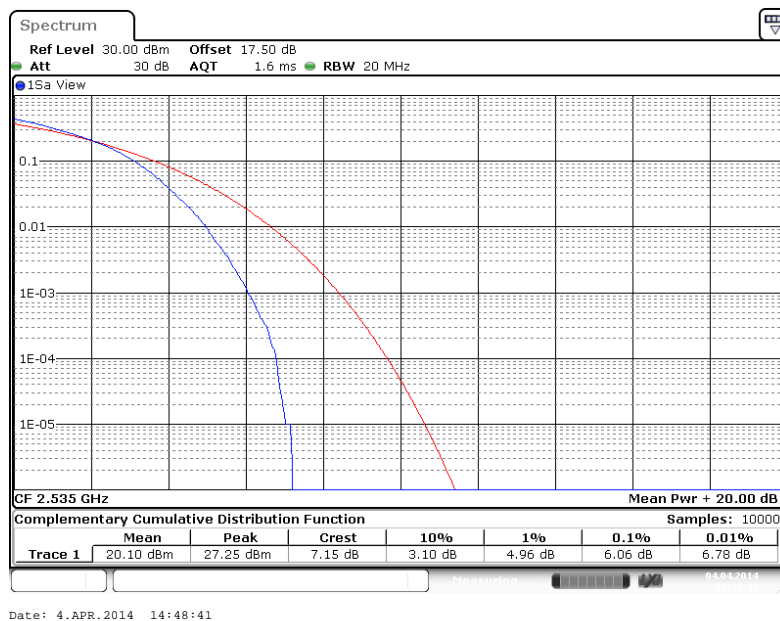

3.3 Equivalent Isotropic Radiated Power Measurement

3.3.1 Description of the EIRP Measurement

Equivalent isotropic radiated power output measurements by substitution method according to ANSI / TIA / EIA-603-C-2004, and the spectrum analyzer configuration follows KDB 971168 D01 Power Meas. License Digital Systems v02r01. Mobile and portable (hand-held) stations operating are limited to average EIRP of 2 watts with LTE band7 and 1 watt with LTE band 4.

3.3.2 Measuring Instruments

The measuring equipment is listed in the section 4 of this test report.

3.3.3 Test Procedures

1. The EUT was placed on a turntable with 1.5 meter height in a fully anechoic chamber.
2. The EUT was set at 3 meters from the receiving antenna, which was mounted on the antenna tower.
3. The radiated emission at the fundamental frequency was measured at 3 m with a test antenna and a spectrum analyzer which used a channel power option across EUT's signal bandwidth per section 4.0 of KDB 971168 D01.
4. The table was rotated 360 degrees to determine the position of the highest radiated power.
5. The height of the receiving antenna is adjusted to look for the maximum ERP/EIRP.
6. Taking the record of maximum ERP/EIRP.
7. A dipole antenna was substituted in place of the EUT and was driven by a signal generator.
8. The conducted power at the terminal of the dipole antenna is measured.
9. Repeat step 3 to step 5 to get the maximum ERP/EIRP of the substitution antenna.
10. $ERP/EIRP = P_s + E_t - E_s + G_s = P_s + R_t - R_s + G_s$

P_s (dBm) : Input power to substitution antenna.

G_s (dBi or dBd) : Substitution antenna Gain.

$E_t = R_t + AF$

$E_s = R_s + AF$

AF (dB/m) : Receive antenna factor

R_t : The highest received signal in spectrum analyzer for EUT.

R_s : The highest received signal in spectrum analyzer for substitution antenna.

3.3.4 Test Setup

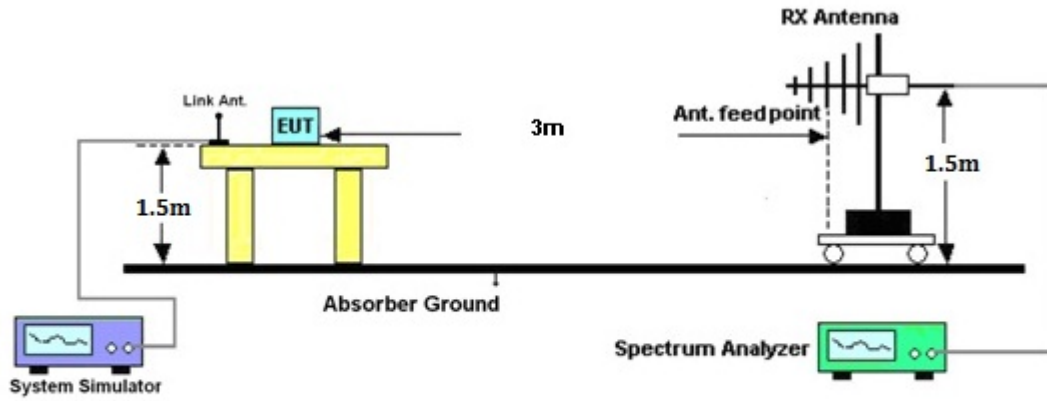

3.3.5 Test Result of EIRP

LTE Band 4 Radiated Power EIRP								
LTE Band	Channel BW (MHz)	Modulation	RB Configuration		Freq. (MHz)	EIRP (dBm)	EIRP (W)	H/V
			RB Size	RB Offset				
4	1.4	QPSK	3	0	1710.7	23.37	0.22	H
4	1.4	QPSK	3	1	1732.5	23.97	0.25	H
4	1.4	QPSK	1	0	1754.3	24.79	0.30	H
4	1.4	QPSK	3	0	1710.7	23.48	0.22	V
4	1.4	QPSK	3	1	1732.5	23.98	0.25	V
4	1.4	QPSK	1	0	1754.3	24.88	0.31	V
4	1.4	16QAM	1	5	1710.7	22.54	0.18	H
4	1.4	16QAM	3	1	1732.5	23.20	0.21	H
4	1.4	16QAM	1	5	1754.3	23.57	0.23	H
4	1.4	16QAM	1	5	1710.7	22.72	0.19	V
4	1.4	16QAM	3	1	1732.5	23.29	0.21	V
4	1.4	16QAM	1	5	1754.3	23.63	0.23	V
4	3	QPSK	1	7	1711.5	23.68	0.23	H
4	3	QPSK	1	0	1732.5	24.39	0.27	H
4	3	QPSK	1	0	1753.5	25.11	0.32	H
4	3	QPSK	1	7	1711.5	23.92	0.25	V
4	3	QPSK	1	0	1732.5	24.44	0.28	V
4	3	QPSK	1	0	1753.5	25.05	0.32	V
4	3	16QAM	1	0	1711.5	22.68	0.19	H
4	3	16QAM	1	7	1732.5	23.76	0.24	H
4	3	16QAM	1	7	1753.5	23.17	0.21	H
4	3	16QAM	1	0	1711.5	22.90	0.19	V
4	3	16QAM	1	7	1732.5	23.89	0.24	V
4	3	16QAM	1	7	1753.5	23.26	0.21	V



LTE Band 4 Radiated Power EIRP								
LTE Band	Channel BW (MHz)	Modulation	RB Configuration		Freq. (MHz)	EIRP (dBm)	EIRP (W)	H/V
			RB Size	RB Offset				
4	5	QPSK	1	24	1712.5	24.07	0.26	H
4	5	QPSK	1	0	1732.5	24.38	0.27	H
4	5	QPSK	1	24	1752.5	25.16	0.33	H
4	5	QPSK	1	24	1712.5	24.23	0.26	V
4	5	QPSK	1	0	1732.5	24.41	0.28	V
4	5	QPSK	1	24	1752.5	25.04	0.32	V
4	5	16QAM	1	0	1712.5	22.64	0.18	H
4	5	16QAM	1	24	1732.5	23.26	0.21	H
4	5	16QAM	1	0	1752.5	23.78	0.24	H
4	5	16QAM	1	0	1712.5	22.80	0.19	V
4	5	16QAM	1	24	1732.5	23.30	0.21	V
4	5	16QAM	1	0	1752.5	23.88	0.24	V
4	10	QPSK	1	0	1715	23.70	0.23	H
4	10	QPSK	1	0	1732.5	24.38	0.27	H
4	10	QPSK	1	24	1750	24.91	0.31	H
4	10	QPSK	1	0	1715	23.93	0.25	V
4	10	QPSK	1	0	1732.5	24.41	0.28	V
4	10	QPSK	1	24	1750	24.90	0.31	V
4	10	16QAM	1	24	1715	22.82	0.19	H
4	10	16QAM	1	49	1732.5	22.95	0.20	H
4	10	16QAM	1	24	1750	23.69	0.23	H
4	10	16QAM	1	24	1715	22.97	0.20	V
4	10	16QAM	1	49	1732.5	22.99	0.20	V
4	10	16QAM	1	24	1750	23.78	0.24	V



LTE Band 4 Radiated Power EIRP								
LTE Band	Channel BW (MHz)	Modulation	RB Configuration		Freq. (MHz)	EIRP (dBm)	EIRP (W)	H/V
			RB Size	RB Offset				
4	15	QPSK	1	0	1717.5	23.71	0.23	H
4	15	QPSK	1	74	1732.5	24.68	0.29	H
4	15	QPSK	1	0	1747.5	24.75	0.30	H
4	15	QPSK	1	0	1717.5	24.03	0.25	V
4	15	QPSK	1	74	1732.5	24.57	0.29	V
4	15	QPSK	1	0	1747.5	24.65	0.29	V
4	15	16QAM	1	37	1717.5	22.88	0.19	H
4	15	16QAM	1	0	1732.5	23.15	0.21	H
4	15	16QAM	1	37	1747.5	23.69	0.23	H
4	15	16QAM	1	37	1717.5	22.95	0.20	V
4	15	16QAM	1	0	1732.5	23.20	0.21	V
4	15	16QAM	1	37	1747.5	23.67	0.23	V
4	20	QPSK	1	0	1720	23.74	0.24	H
4	20	QPSK	1	49	1732.5	24.64	0.29	H
4	20	QPSK	1	0	1745	24.69	0.29	H
4	20	QPSK	1	0	1720	23.91	0.25	V
4	20	QPSK	1	49	1732.5	24.78	0.30	V
4	20	QPSK	1	0	1745	24.57	0.29	V
4	20	16QAM	1	0	1720	22.54	0.18	H
4	20	16QAM	1	49	1732.5	23.17	0.21	H
4	20	16QAM	1	49	1745	23.64	0.23	H
4	20	16QAM	1	0	1720	22.74	0.19	V
4	20	16QAM	1	49	1732.5	23.32	0.21	V
4	20	16QAM	1	49	1745	23.59	0.23	V



LTE Band 7 Radiated Power EIRP								
LTE Band	Channel BW (MHz)	Modulation	RB Configuration		Freq. (MHz)	EIRP (dBm)	EIRP (W)	H/V
			RB Size	RB Offset				
7	5	QPSK	1	0	2502.5	23.34	0.22	H
7	5	QPSK	1	12	2535	24.53	0.28	H
7	5	QPSK	1	24	2567.5	23.46	0.22	H
7	5	QPSK	1	0	2502.5	23.19	0.21	V
7	5	QPSK	1	12	2535	24.33	0.27	V
7	5	QPSK	1	24	2567.5	23.70	0.23	V
7	5	16QAM	1	0	2502.5	22.21	0.17	H
7	5	16QAM	1	0	2535	23.45	0.22	H
7	5	16QAM	1	0	2567.5	24.53	0.28	H
7	5	16QAM	1	0	2502.5	21.99	0.16	V
7	5	16QAM	1	0	2535	23.25	0.21	V
7	5	16QAM	1	0	2567.5	24.39	0.27	V
7	10	QPSK	1	0	2505	23.37	0.22	H
7	10	QPSK	1	0	2535	24.06	0.25	H
7	10	QPSK	1	24	2565	23.58	0.23	H
7	10	QPSK	1	0	2505	23.19	0.21	V
7	10	QPSK	1	0	2535	23.91	0.25	V
7	10	QPSK	1	24	2565	23.67	0.23	V
7	10	16QAM	1	24	2505	22.38	0.17	H
7	10	16QAM	1	49	2535	23.76	0.24	H
7	10	16QAM	1	0	2565	23.58	0.23	H
7	10	16QAM	1	24	2505	22.06	0.16	V
7	10	16QAM	1	49	2535	23.52	0.22	V
7	10	16QAM	1	0	2565	23.61	0.23	V



LTE Band 7 Radiated Power EIRP								
LTE Band	Channel BW (MHz)	Modulation	RB Configuration		Freq. (MHz)	EIRP (dBm)	EIRP (W)	H/V
			RB Size	RB Offset				
7	15	QPSK	1	0	2507.5	23.35	0.22	H
7	15	QPSK	1	74	2535	24.47	0.28	H
7	15	QPSK	1	74	2562.5	24.46	0.28	H
7	15	QPSK	1	0	2507.5	23.28	0.21	V
7	15	QPSK	1	74	2535	24.31	0.27	V
7	15	QPSK	1	74	2562.5	24.55	0.29	V
7	15	16QAM	1	37	2507.5	22.54	0.18	H
7	15	16QAM	1	74	2535	23.80	0.24	H
7	15	16QAM	1	0	2562.5	23.52	0.22	H
7	15	16QAM	1	37	2507.5	22.20	0.17	V
7	15	16QAM	1	74	2535	23.58	0.23	V
7	15	16QAM	1	0	2562.5	23.48	0.22	V
7	20	QPSK	1	0	2510	23.23	0.21	H
7	20	QPSK	1	49	2535	24.56	0.29	H
7	20	QPSK	1	49	2560	24.71	0.30	H
7	20	QPSK	1	0	2510	23.21	0.21	V
7	20	QPSK	1	49	2535	24.36	0.27	V
7	20	QPSK	1	49	2560	24.71	0.30	V
7	20	16QAM	1	99	2510	22.93	0.20	H
7	20	16QAM	1	0	2535	23.25	0.21	H
7	20	16QAM	1	99	2560	23.62	0.23	H
7	20	16QAM	1	99	2510	22.81	0.19	V
7	20	16QAM	1	0	2535	23.46	0.22	V
7	20	16QAM	1	99	2560	23.71	0.23	V

3.4 99% Occupied Bandwidth and 26dB Bandwidth Measurement

3.4.1 Description of 99% Occupied Bandwidth and 26dB Bandwidth Measurement

The occupied bandwidth is the width of a frequency band such that, below the lower and above the upper frequency limits, the mean powers emitted are each equal to a specified percentage 0.5% of the total mean transmitted power.

The 26 dB emission bandwidth is defined as the frequency range between two points, one above and one below the carrier frequency, at which the spectral density of the emission is attenuated 26 dB below the maximum in-band spectral density of the modulated signal. Spectral density (power per unit bandwidth) is to be measured with a detector of resolution bandwidth equal to approximately 1.0% of the emission bandwidth.

3.4.2 Measuring Instruments

The measuring equipment is listed in the section 4 of this test report.

3.4.3 Test Procedures

1. The EUT was connected to spectrum analyzer and system simulator via a power divider.
2. The 26dB and 99% occupied bandwidth (BW) of the middle channel for the highest RF power with full RB sizes were measured.

3.4.4 Test Setup

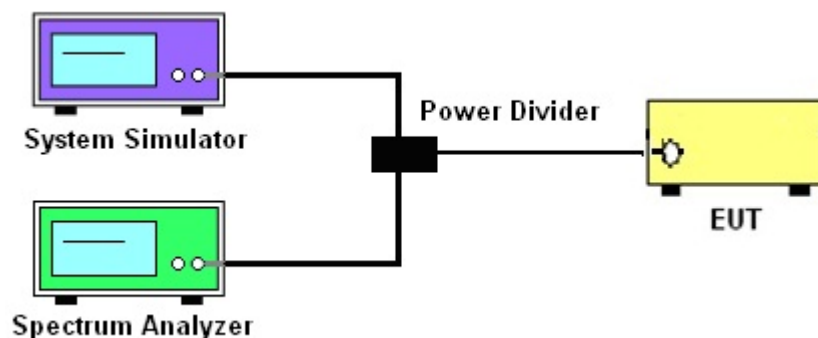

3.4.5 Test Result of 99% Occupied Bandwidth and 26dB Bandwidth

Modes	LTE Band 4			
BW / Mod.	1.4MHz / QPSK	1.4MHz / 16QAM	3MHz / QPSK	3MHz / 16QAM
99% OBW (MHz)	1.10	1.10	2.73	2.73
26dB BW (MHz)	1.28	1.29	3.05	3.05
BW / Mod.	5MHz / QPSK	5MHz / 16QAM	10MHz / QPSK	10MHz / 16QAM
99% OBW (MHz)	4.50	4.50	9.09	9.01
26dB BW (MHz)	5.05	5.03	10.07	9.99
BW / Mod.	15MHz / QPSK	15MHz / 16QAM	20MHz / QPSK	20MHz / 16QAM
99% OBW (MHz)	13.43	13.43	18.34	18.26
26dB BW (MHz)	14.75	14.84	20.42	20.34

Modes	LTE Band 7			
BW / Mod.	5MHz / QPSK	5MHz / 16QAM	10MHz / QPSK	10MHz / 16QAM
99% OBW (MHz)	4.50	4.50	9.07	9.01
26dB BW (MHz)	5.06	5.05	10.03	9.97
BW / Mod.	15MHz / QPSK	15MHz / 16QAM	20MHz / QPSK	20MHz / 16QAM
99% OBW (MHz)	13.46	13.43	18.34	18.30
26dB BW (MHz)	14.75	14.81	20.46	20.30

Note:

The maximum RB configurations of the 99% Occupied Bandwidth and 26dB Bandwidth summary as below:

- BW1.4MHz RB setting : RB Size 6, RB offset 0
- BW3.0MHz RB setting : RB Size 15, RB offset 0
- BW5.0MHz RB setting : RB Size 25, RB offset 0
- BW10MHz RB setting : RB Size 50, RB offset 0
- BW15MHz RB setting : RB Size 75, RB offset 0
- BW20MHz RB setting : RB Size 100, RB offset 0

3.4.6 Test Result (Plots) of 99% Occupied Bandwidth and 26dB Bandwidth

Band :	LTE Band 4	BW / Mod. :	1.4MHz / QPSK
--------	------------	-------------	---------------

99% Occupied Bandwidth Plot on Channel 20175

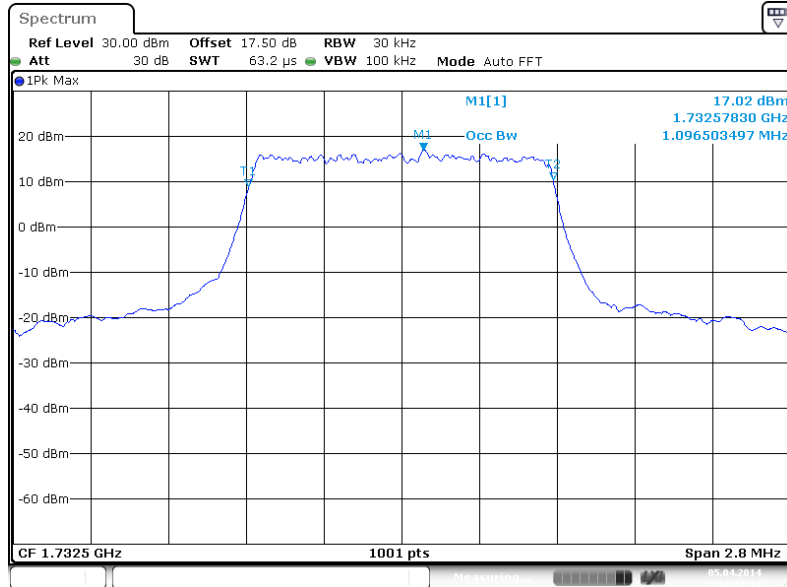

26dB Bandwidth Plot on Channel 20175

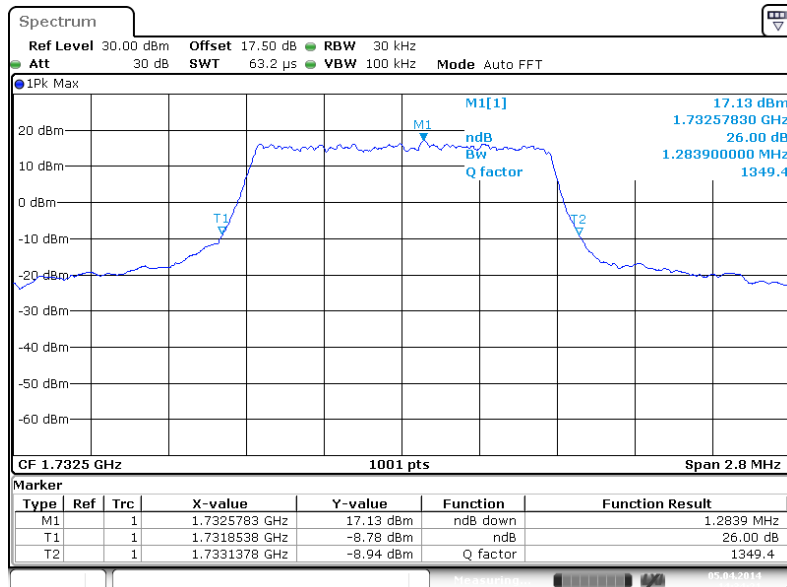



Band :	LTE Band 4	BW / Mod. :	1.4MHz / 16QAM
--------	------------	-------------	----------------

99% Occupied Bandwidth Plot on Channel 20175

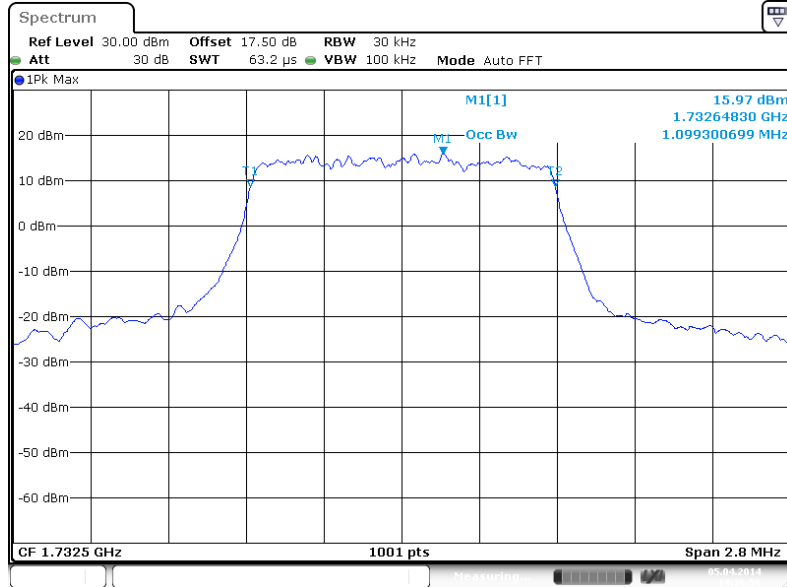

26dB Bandwidth Plot on Channel 20175

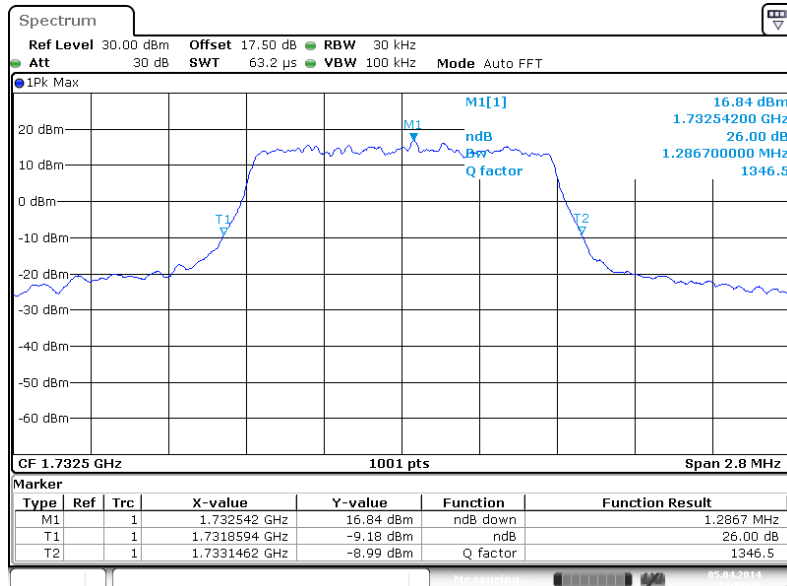



Band :	LTE Band 4	BW / Mod. :	3MHz / QPSK
--------	------------	-------------	-------------

99% Occupied Bandwidth Plot on Channel 20175

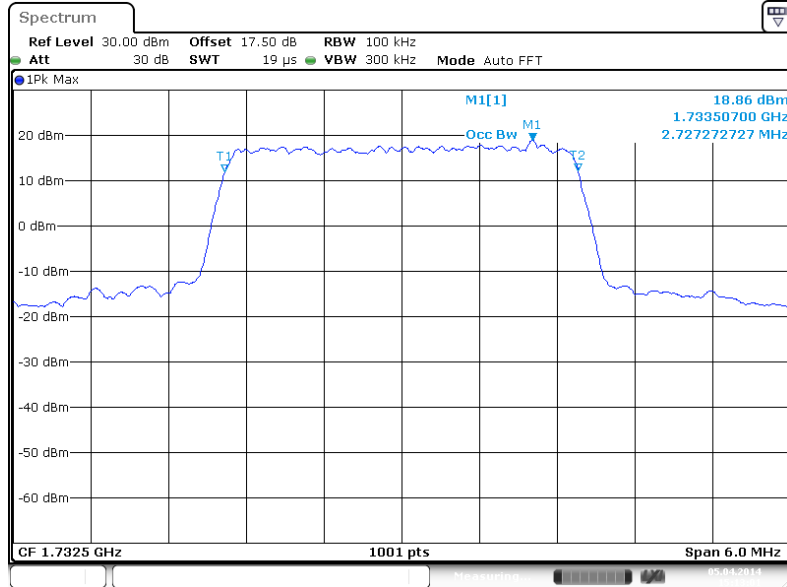

26dB Bandwidth Plot on Channel 20175

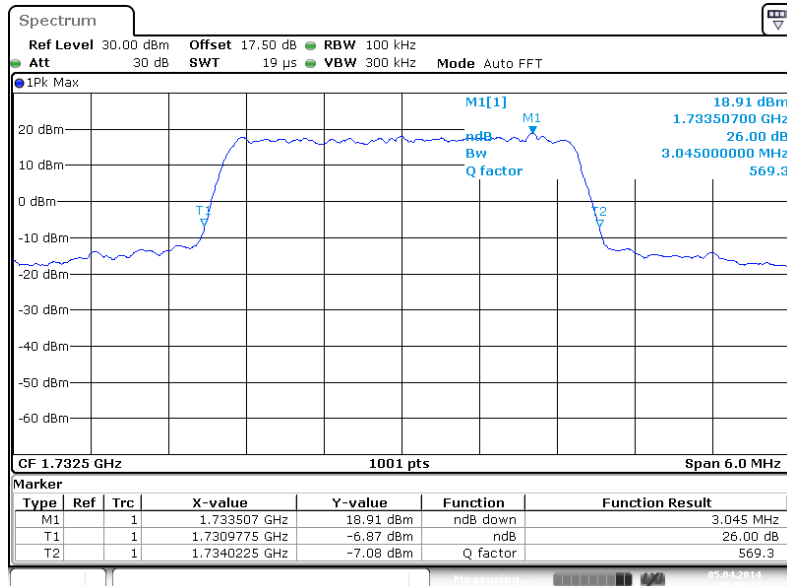



Band :	LTE Band 4	BW / Mod. :	3MHz / 16QAM
---------------	------------	--------------------	--------------

99% Occupied Bandwidth Plot on Channel 20175

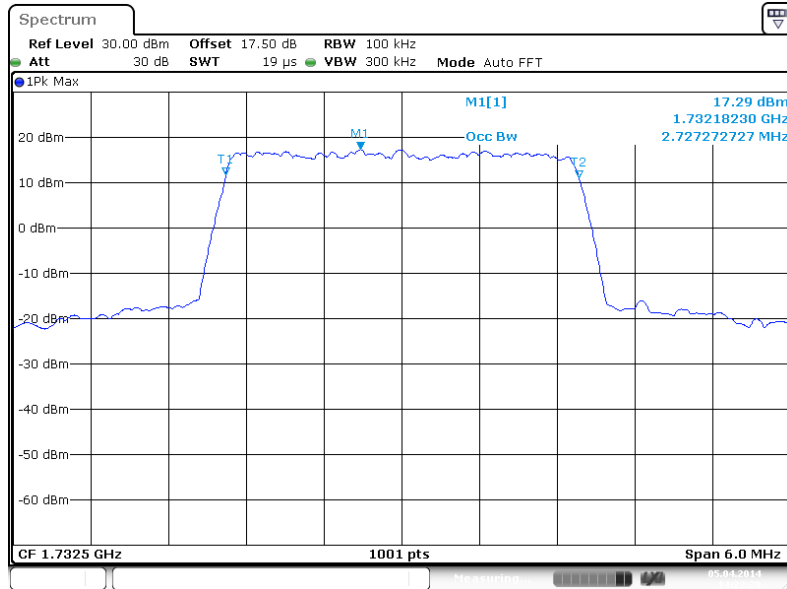

26dB Bandwidth Plot on Channel 20175

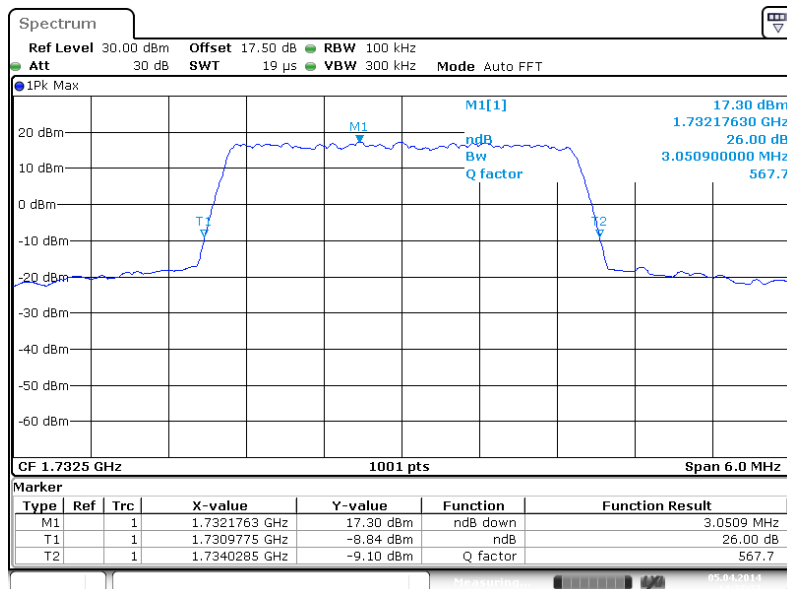



Band :	LTE Band 4	BW / Mod. :	5MHz / QPSK
---------------	------------	--------------------	-------------

99% Occupied Bandwidth Plot on Channel 20175

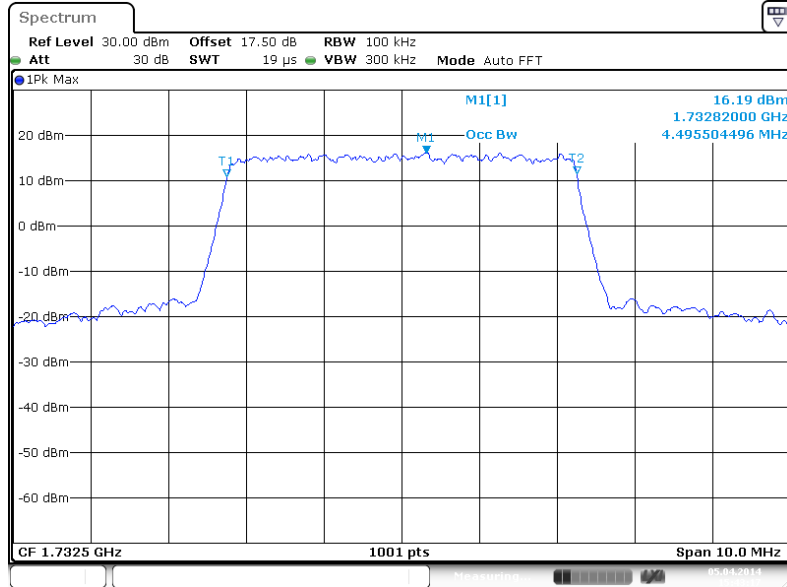

26dB Bandwidth Plot on Channel 20175

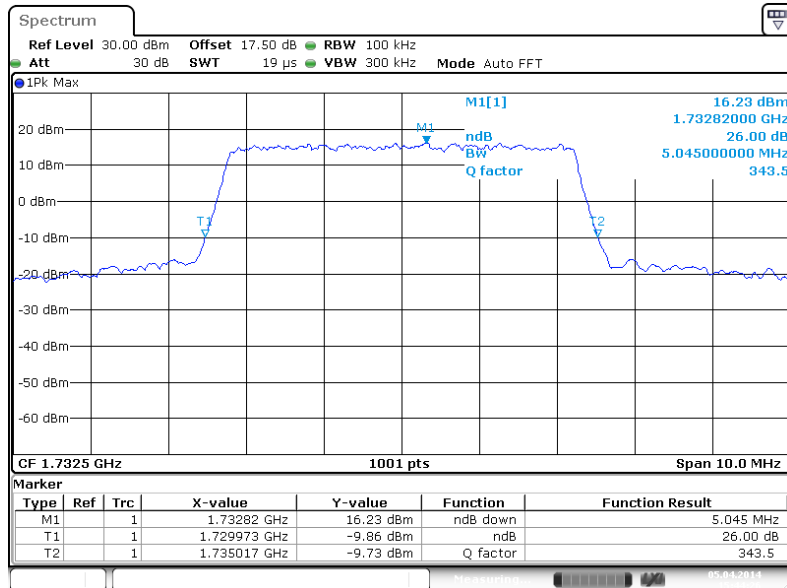



Band :	LTE Band 4	BW / Mod. :	5MHz / 16QAM
---------------	------------	--------------------	--------------

99% Occupied Bandwidth Plot on Channel 20175

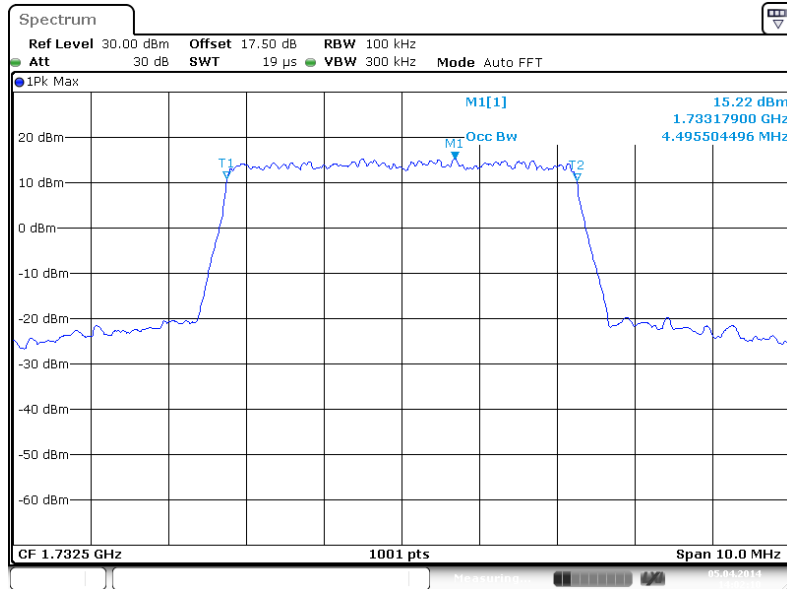

26dB Bandwidth Plot on Channel 20175

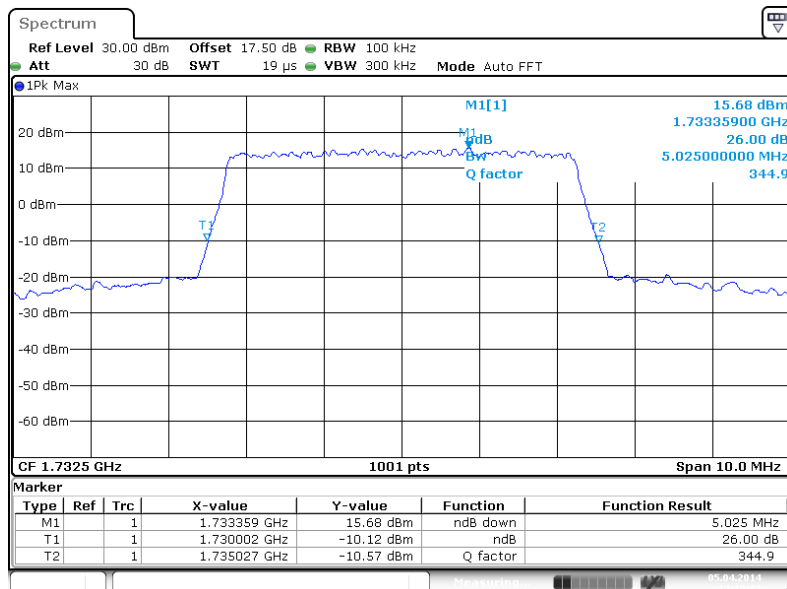



Band :	LTE Band 4	BW / Mod. :	10MHz / QPSK
--------	------------	-------------	--------------

99% Occupied Bandwidth Plot on Channel 20175

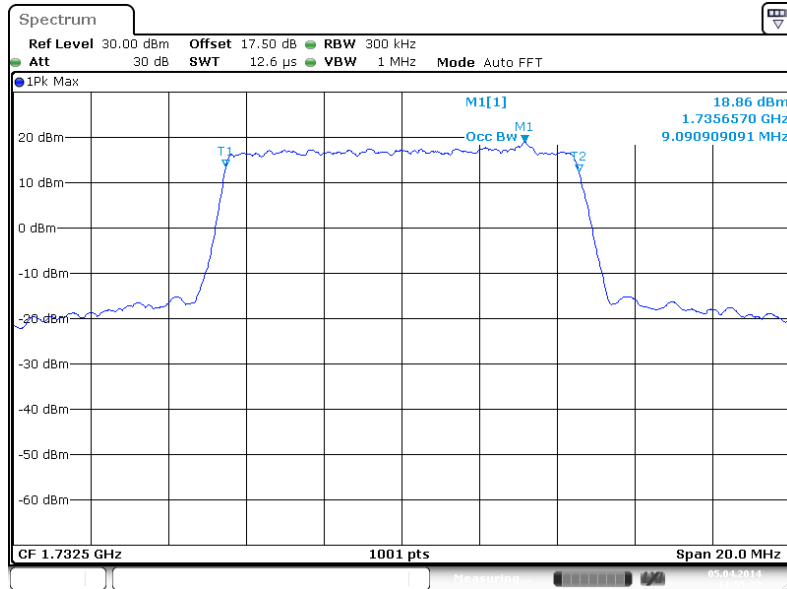

26dB Bandwidth Plot on Channel 20175

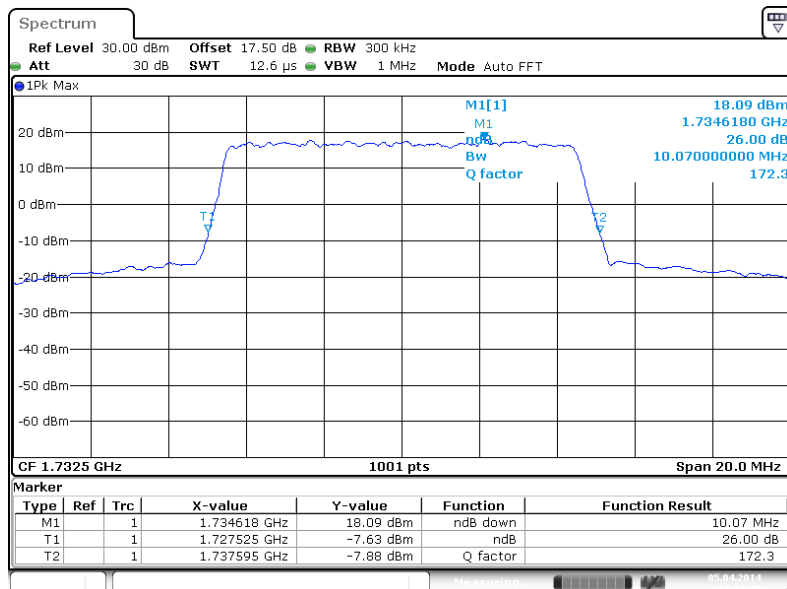



Band :	LTE Band 4	BW / Mod. :	10MHz / 16QAM
--------	------------	-------------	---------------

99% Occupied Bandwidth Plot on Channel 20175

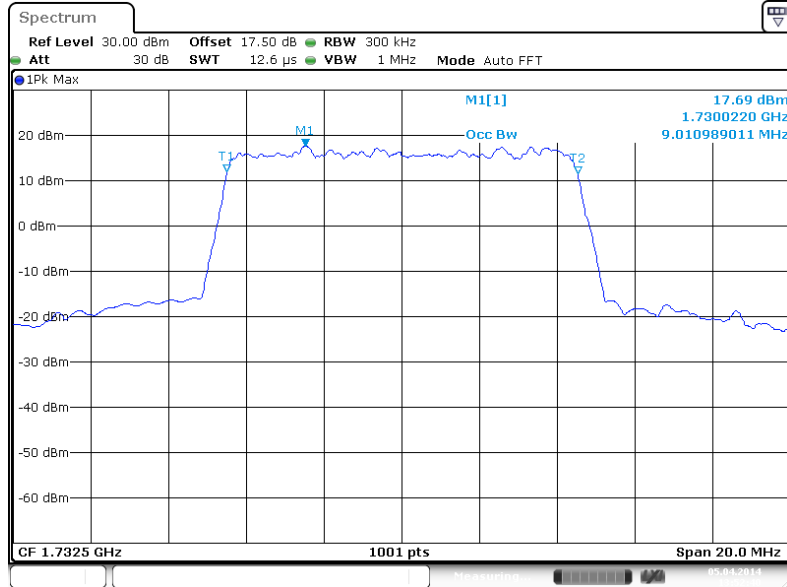

26dB Bandwidth Plot on Channel 20175

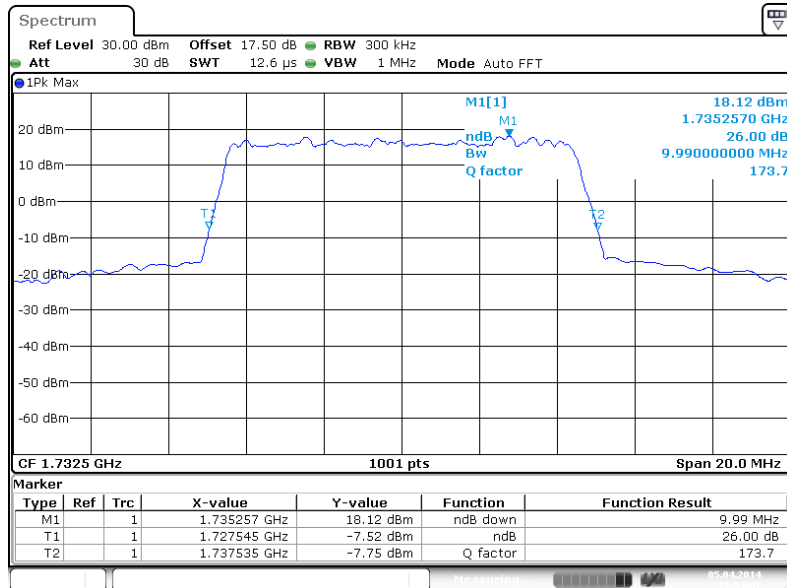



Band :	LTE Band 4	BW / Mod. :	15MHz / QPSK
--------	------------	-------------	--------------

99% Occupied Bandwidth Plot on Channel 20175

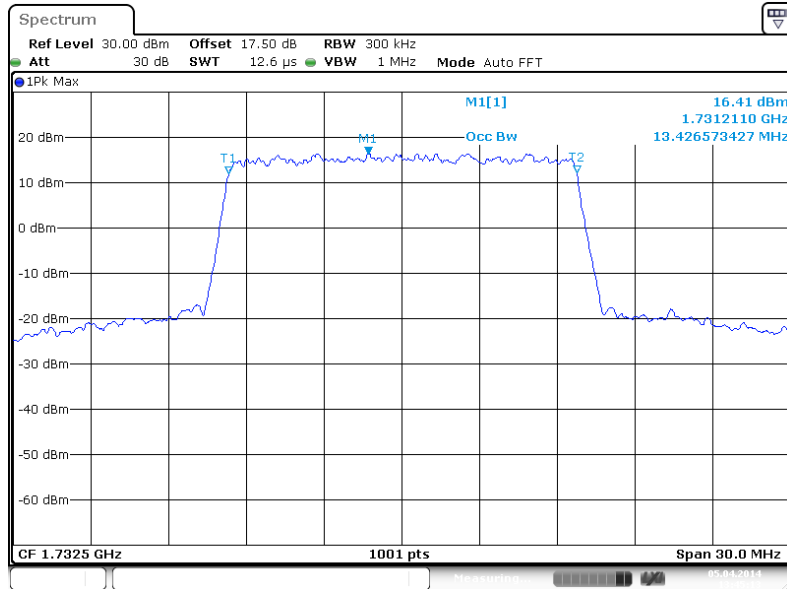

26dB Bandwidth Plot on Channel 20175

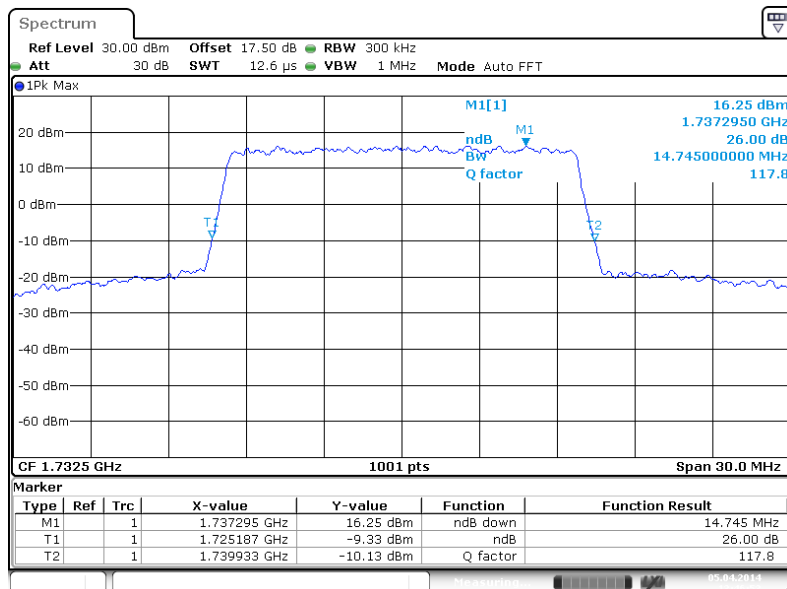



Band :	LTE Band 4	BW / Mod. :	15MHz / 16QAM
---------------	------------	--------------------	---------------

99% Occupied Bandwidth Plot on Channel 20175

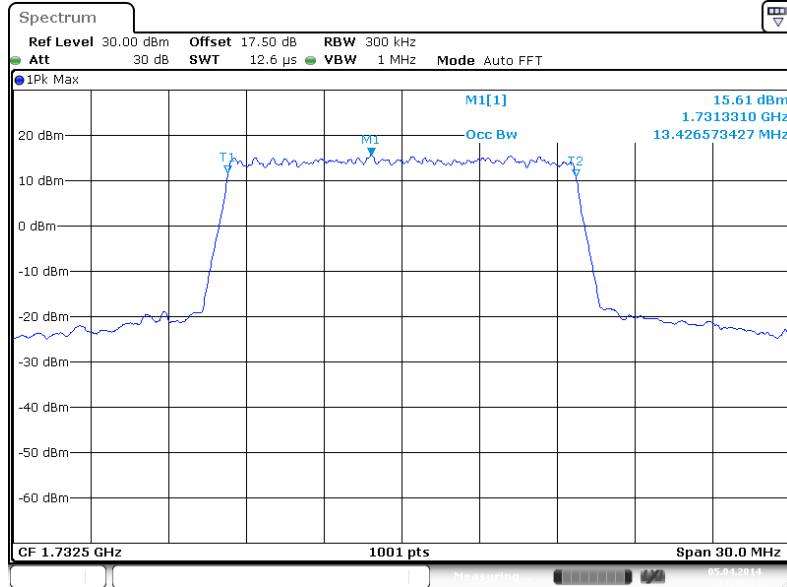

26dB Bandwidth Plot on Channel 20175

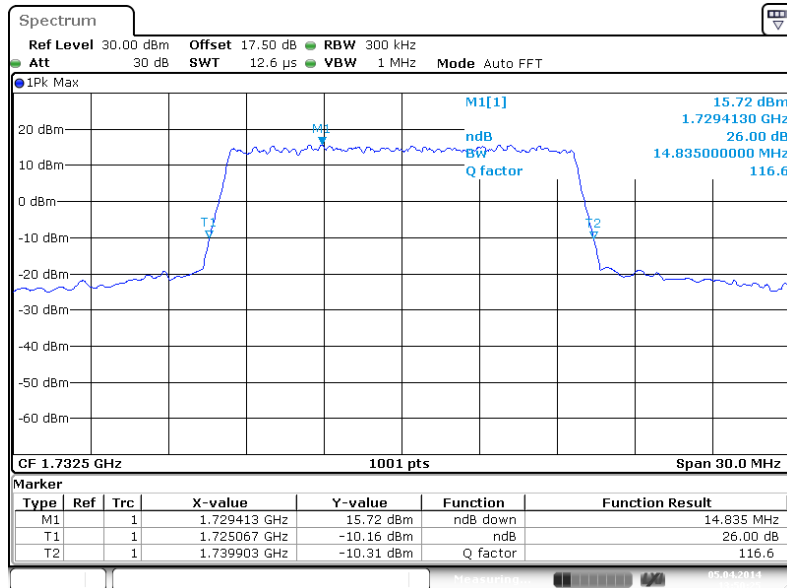



Band :	LTE Band 4	BW / Mod. :	20MHz / QPSK
--------	------------	-------------	--------------

99% Occupied Bandwidth Plot on Channel 20175

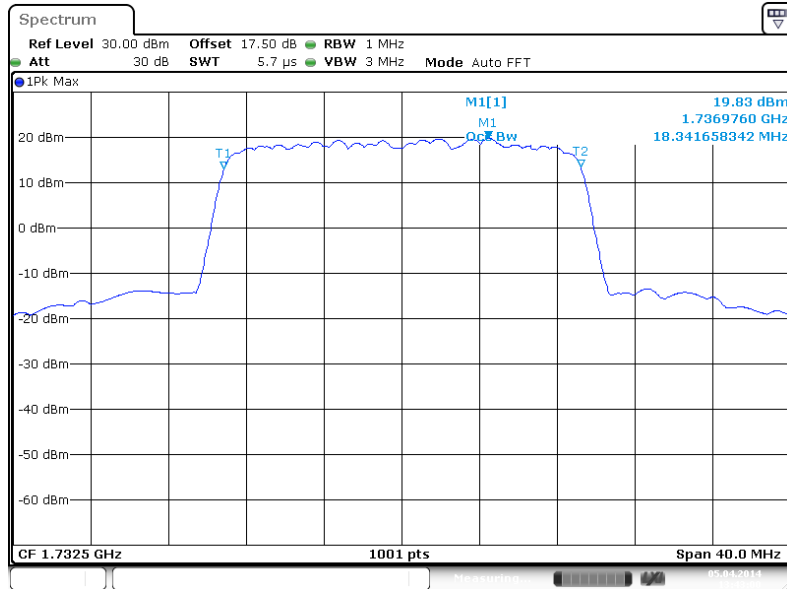

26dB Bandwidth Plot on Channel 20175

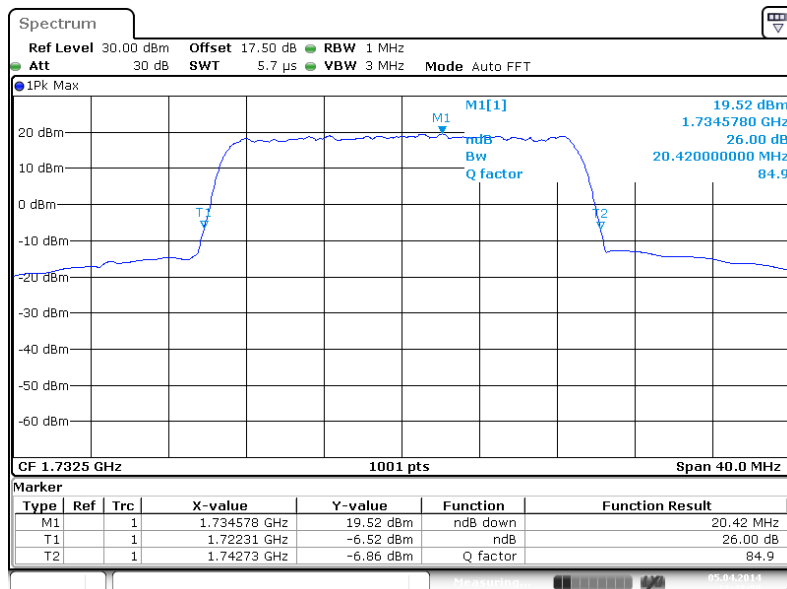



Band :	LTE Band 4	BW / Mod. :	20MHz / 16QAM
---------------	------------	--------------------	---------------

99% Occupied Bandwidth Plot on Channel 20175

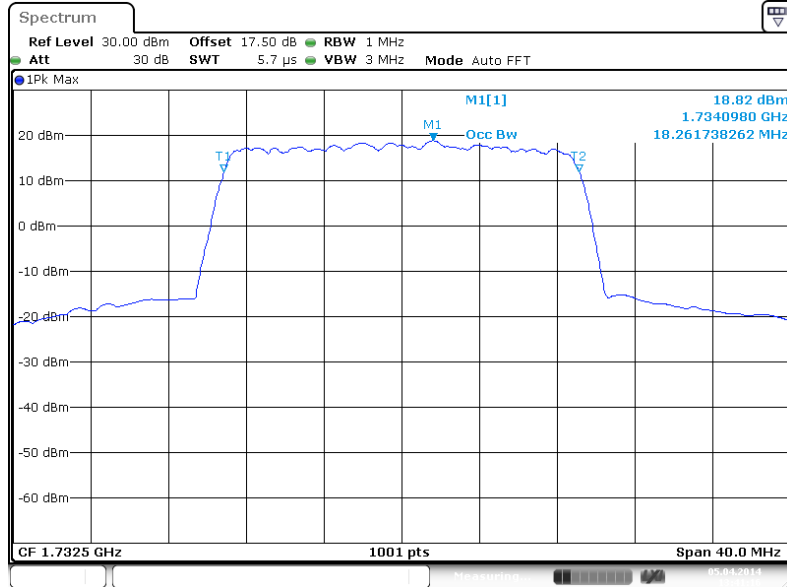

26dB Bandwidth Plot on Channel 20175

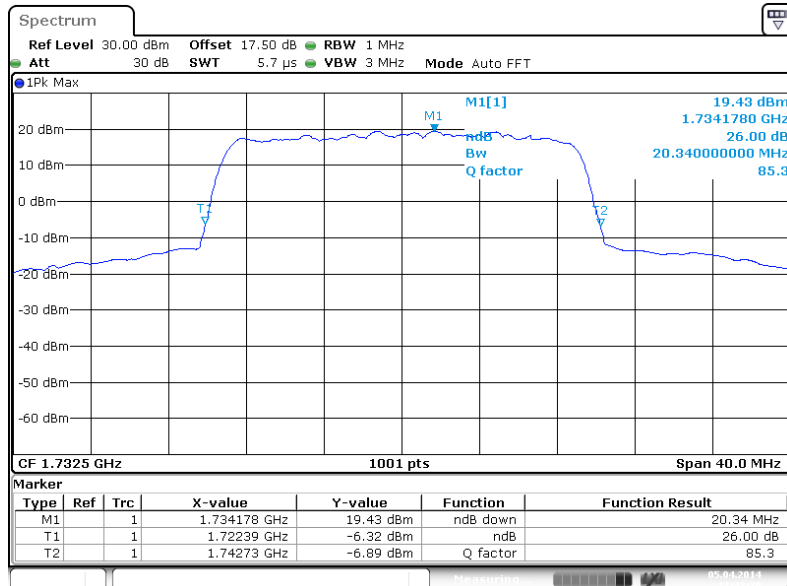



Band :	LTE Band 7	BW / Mod. :	5MHz / QPSK
---------------	------------	--------------------	-------------

99% Occupied Bandwidth Plot on Channel 21100

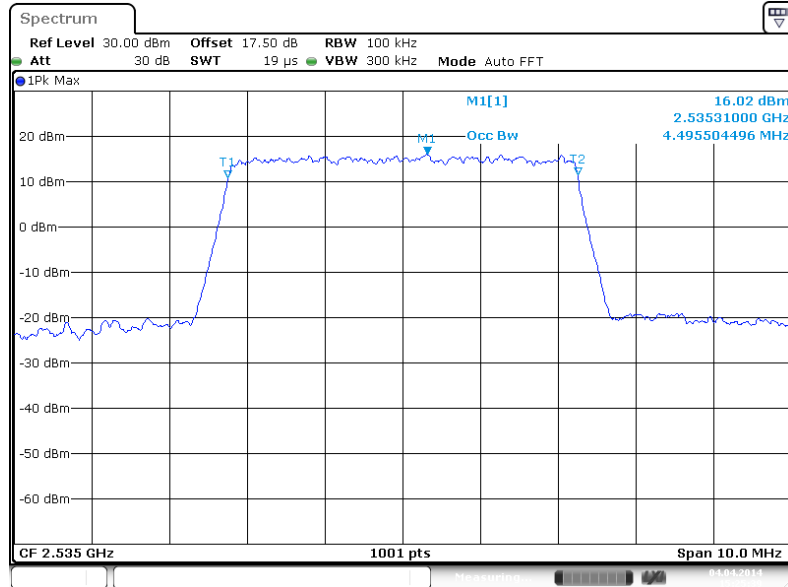

26dB Bandwidth Plot on Channel 21100

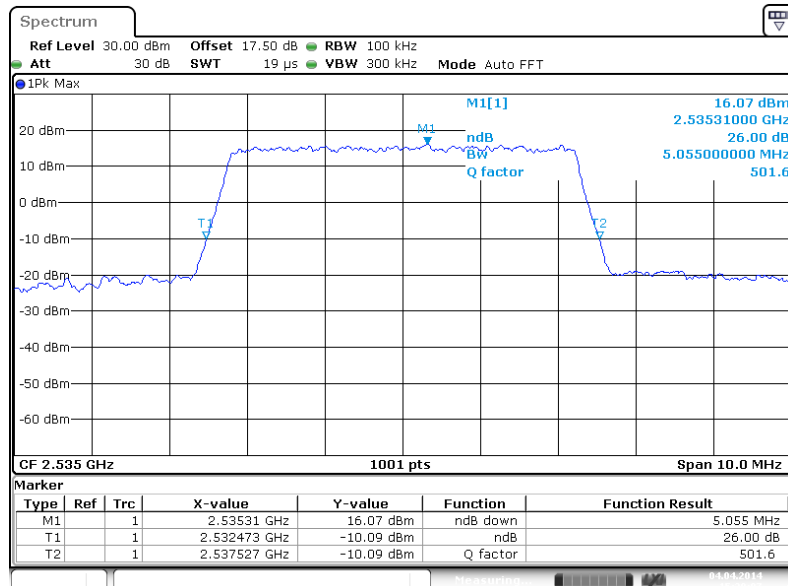



Band :	LTE Band 7	BW / Mod. :	5MHz / 16QAM
---------------	------------	--------------------	--------------

99% Occupied Bandwidth Plot on Channel 21100

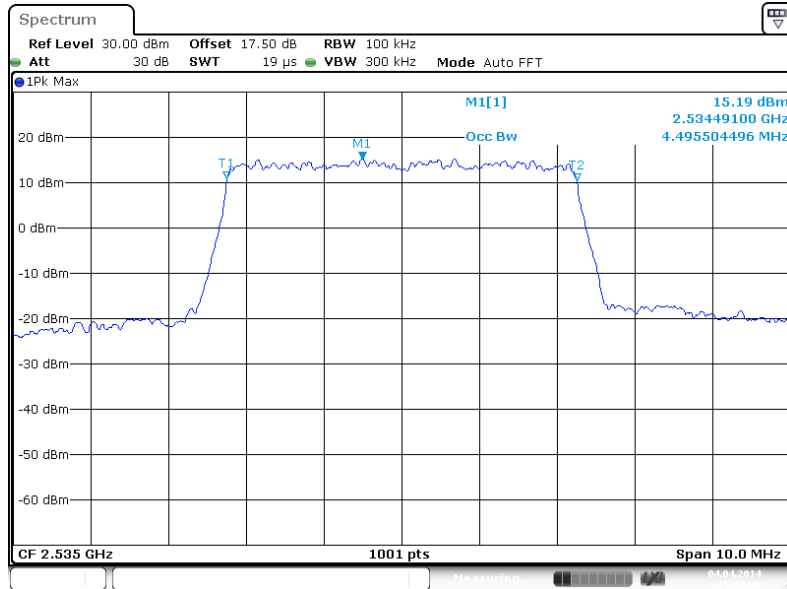

26dB Bandwidth Plot on Channel 21100

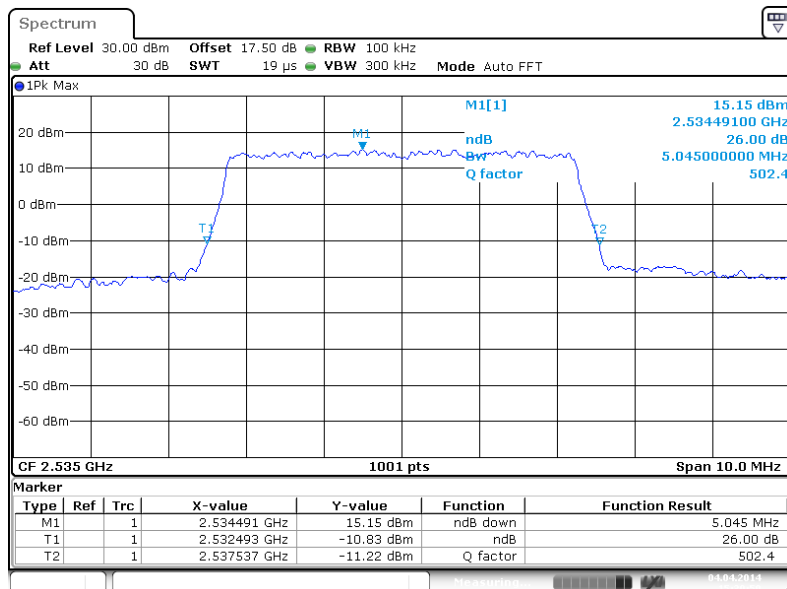



Band :	LTE Band 7	BW / Mod. :	10MHz / QPSK
--------	------------	-------------	--------------

99% Occupied Bandwidth Plot on Channel 21100

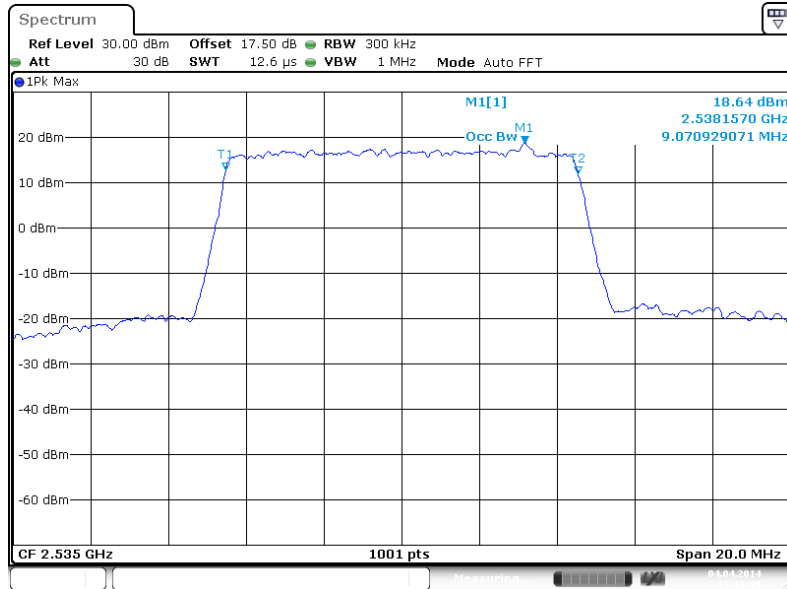

26dB Bandwidth Plot on Channel 21100

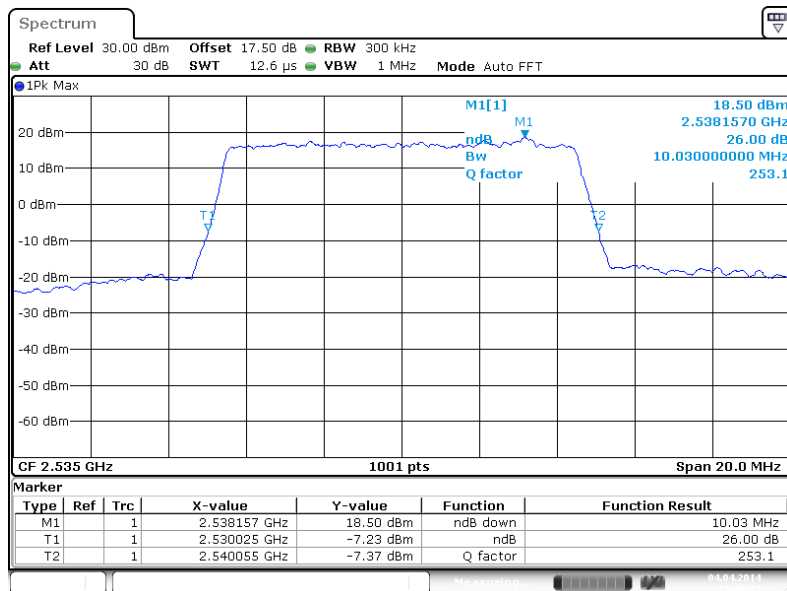



Band :	LTE Band 7	BW / Mod. :	10MHz / 16QAM
--------	------------	-------------	---------------

99% Occupied Bandwidth Plot on Channel 21100

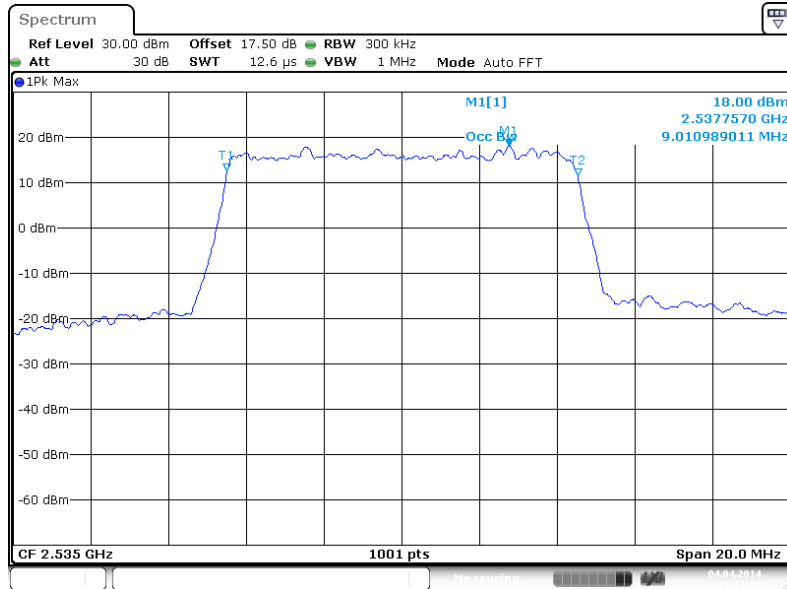

26dB Bandwidth Plot on Channel 21100

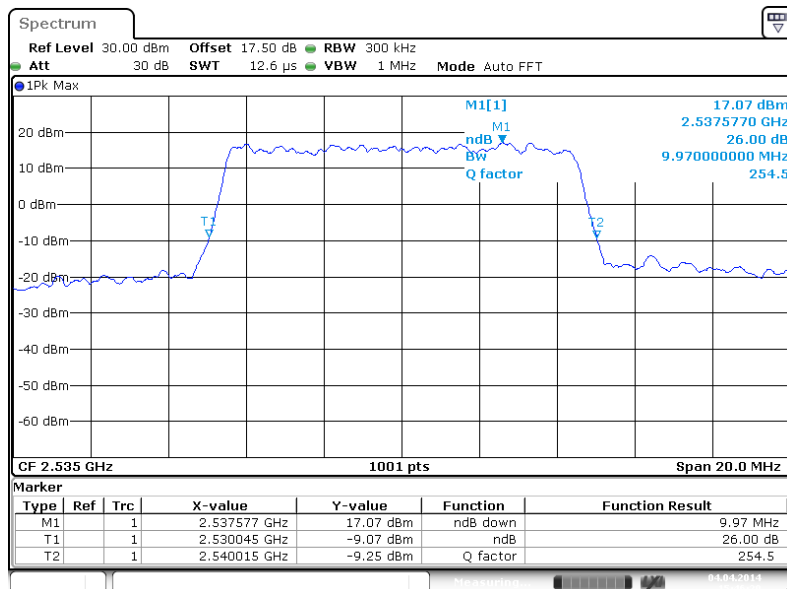



Band :	LTE Band 7	BW / Mod. :	15MHz / QPSK
--------	------------	-------------	--------------

99% Occupied Bandwidth Plot on Channel 21100

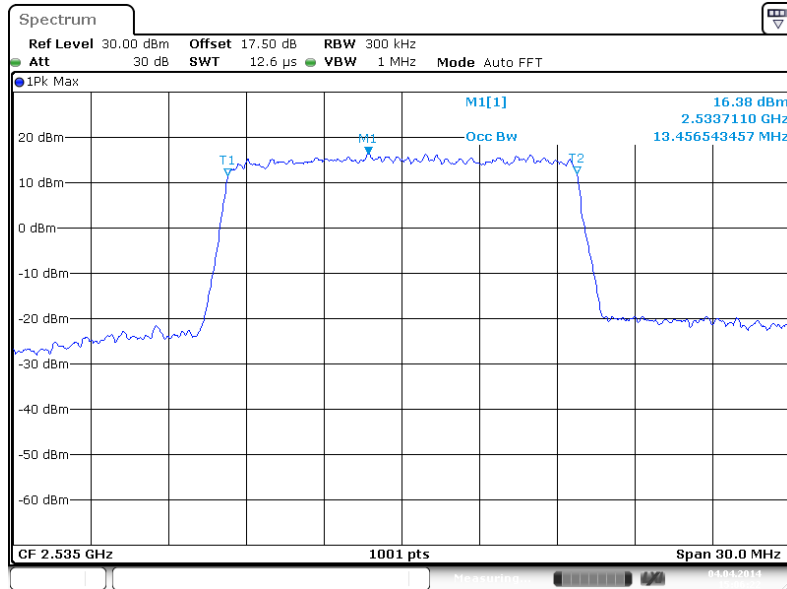

26dB Bandwidth Plot on Channel 21100

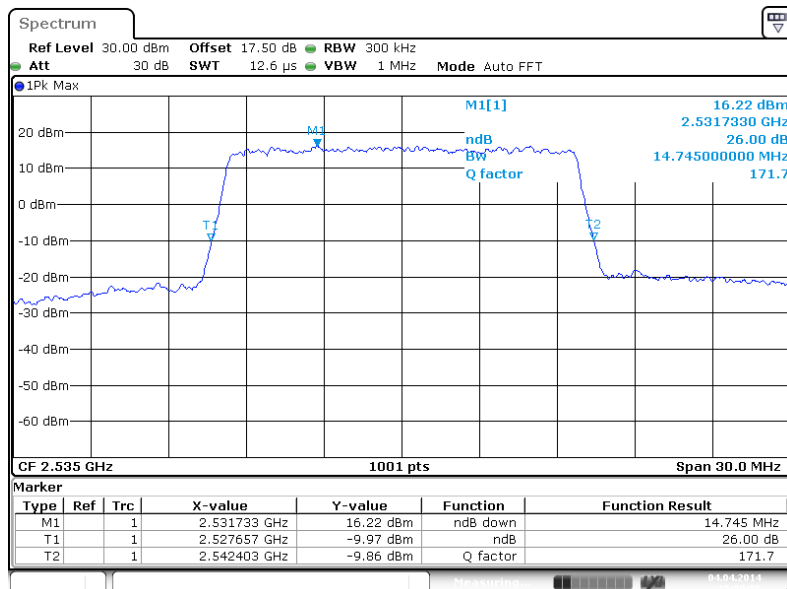



Band :	LTE Band 7	BW / Mod. :	15MHz / 16QAM
---------------	------------	--------------------	---------------

99% Occupied Bandwidth Plot on Channel 21100

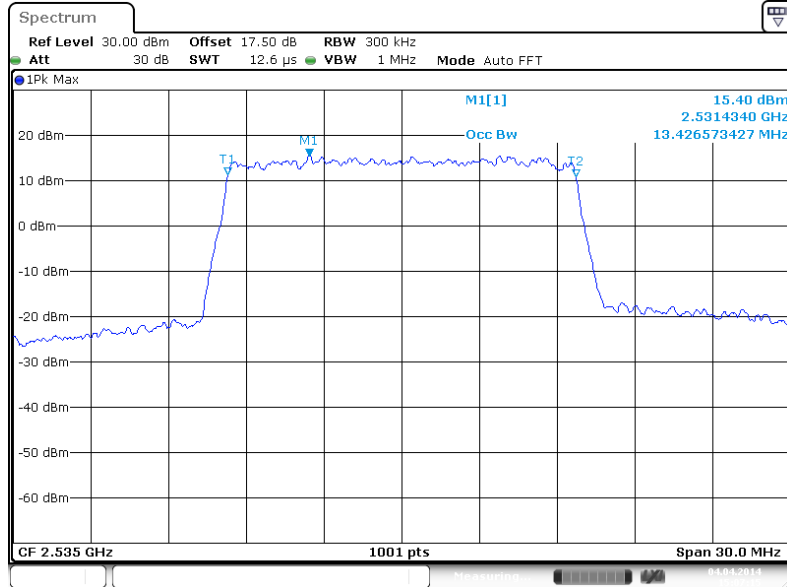

26dB Bandwidth Plot on Channel 21100

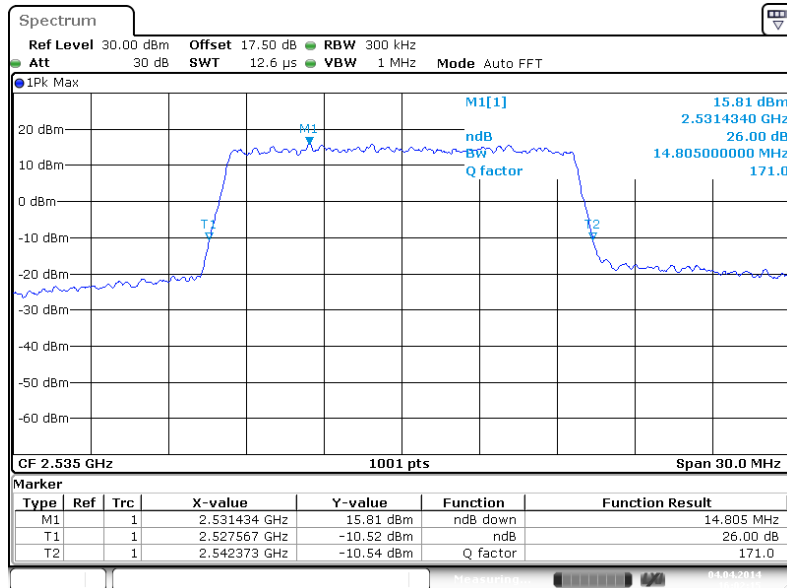



Band :	LTE Band 7	BW / Mod. :	20MHz / QPSK
--------	------------	-------------	--------------

99% Occupied Bandwidth Plot on Channel 21100

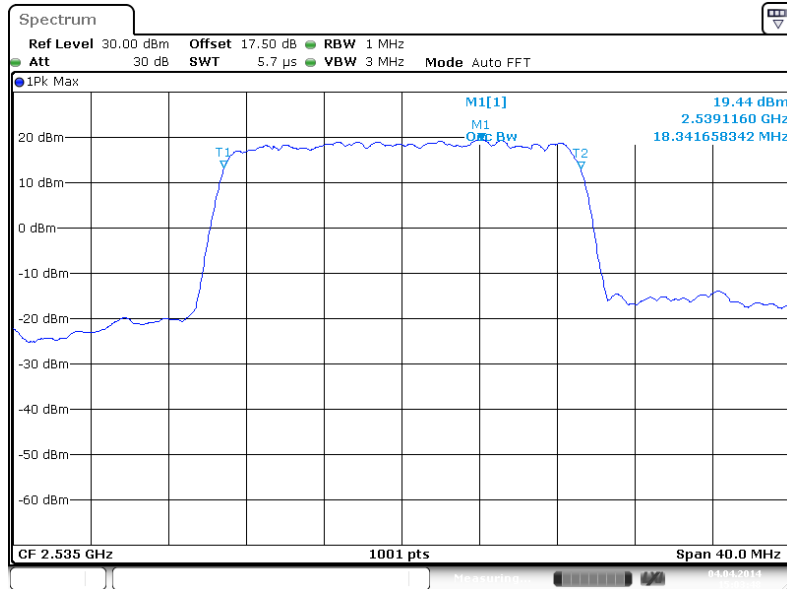

26dB Bandwidth Plot on Channel 21100

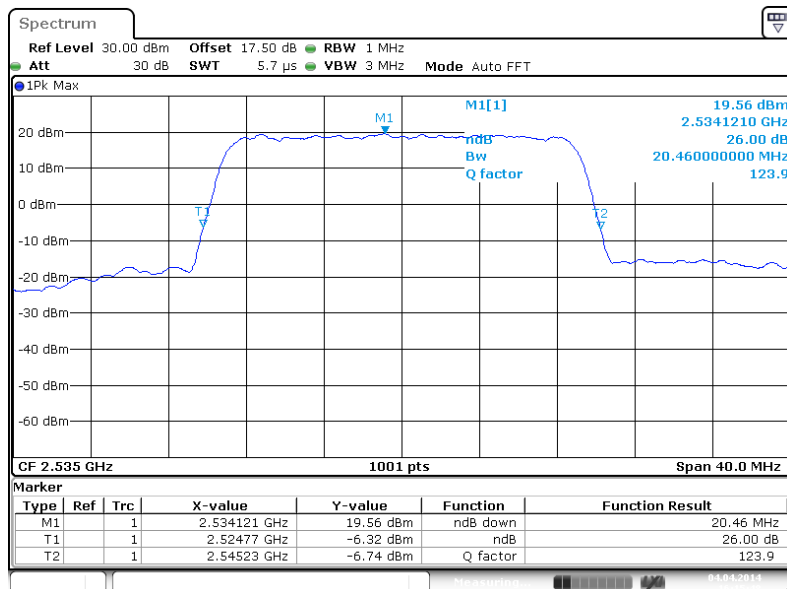



Band :	LTE Band 7	BW / Mod. :	20MHz / 16QAM
---------------	------------	--------------------	---------------

99% Occupied Bandwidth Plot on Channel 21100

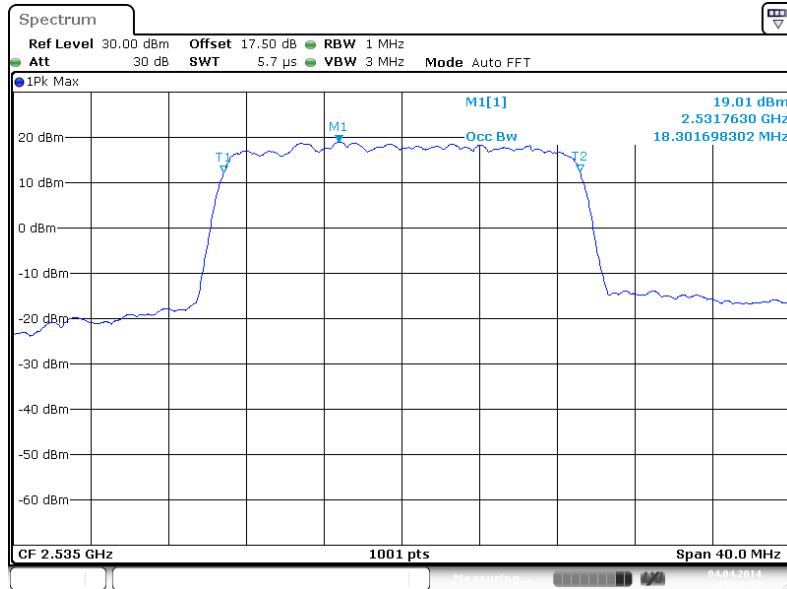

26dB Bandwidth Plot on Channel 21100

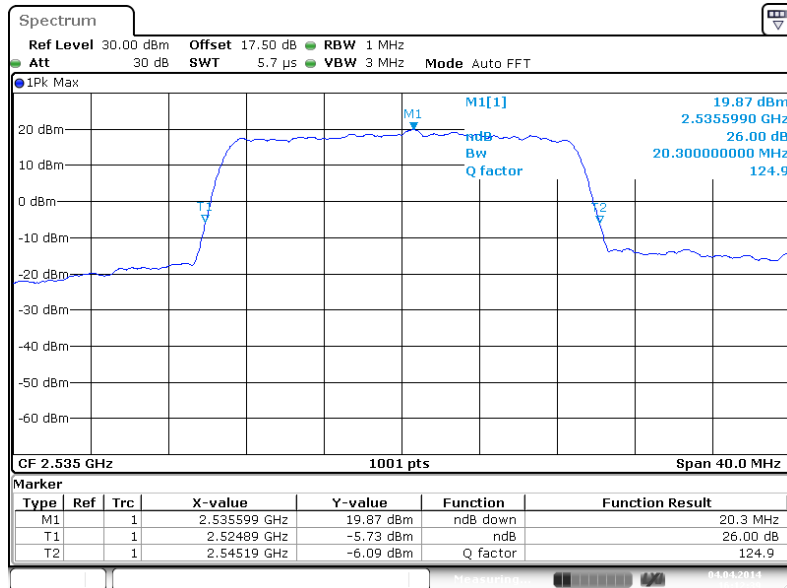

3.5 Conducted Band Edge Measurement

3.5.1 Description of Conducted Band Edge Measurement

27.53 (g) for Band 4

For operations in the 1710 – 1755 MHz band, the FCC limit is $43 + 10\log_{10}(P[\text{Watts}])$ dB below the transmitter power $P(\text{Watts})$ in a 1 MHz bandwidth. However, in the 1MHz bands immediately outside and adjacent to the licensee's frequency block, a resolution bandwidth of at least one percent of the emission bandwidth of the fundamental emission of the transmitter may be employed.

27.53 (l)(4) for Band 7

The emissions be operated in the 2496-2690 MHz band, the attenuation factor of transmitter Power (P) shall be not less than $43 + 10 \log (P)$ dB at the channel edge and $55 + 10 \log (P)$ dB at 5.5 MHz from the channel edges.

3.5.2 Measuring Instruments

The measuring equipment is listed in the section 4 of this test report.

3.5.3 Test Procedures

1. The EUT was connected to spectrum analyzer and system simulator via a power divider.
2. The band edges of low and high channels for the highest RF powers were measured. Set RBW $\geq 1\%$ EBW in the 1MHz band immediately outside and adjacent to the band edge.
3. Set spectrum analyzer with RMS detector.
4. The RF fundamental frequency should be excluded against the limit line in the operating frequency band.

5. For LTE Band 4:

The limit line is derived from $43 + 10\log(P)$ dB below the transmitter power $P(\text{Watts})$
 $= P(\text{W}) - [43 + 10\log(P)] (\text{dB})$
 $= [30 + 10\log(P)] (\text{dBm}) - [43 + 10\log(P)] (\text{dB})$
 $= -13\text{dBm}.$

6. For LTE Band 7:

The limit line is derived from $55 + 10\log(P)$ dB below the transmitter power $P(\text{Watts})$
 $= P(\text{W}) - [55 + 10\log(P)] (\text{dB})$
 $= [30 + 10\log(P)] (\text{dBm}) - [55 + 10\log(P)] (\text{dB})$
 $= -25\text{dBm}.$

3.5.4 Test Setup

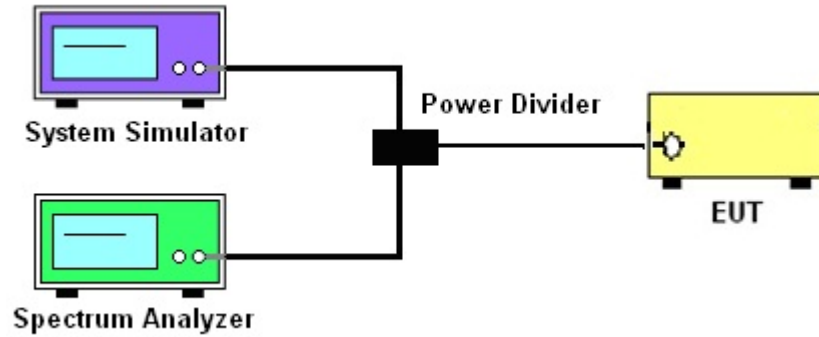



3.5.5 Test Result (Plots) of Conducted Band Edge

Band :	LTE Band 4	Band Width :	1.4MHz / QPSK
--------	------------	--------------	---------------

Lower Band Edge Plot for QPSK-RB Size 1, RB Offset 0

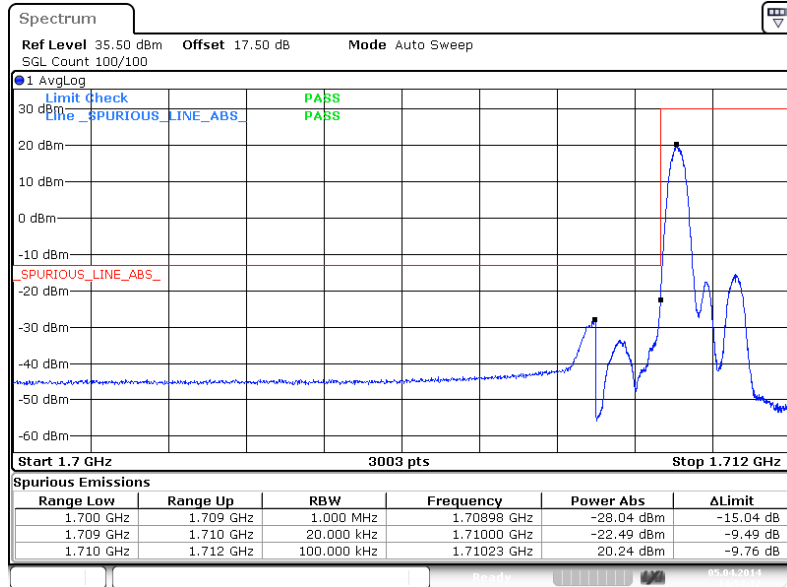

Lower Band Edge Plot for QPSK-RB Size 6, RB Offset 0

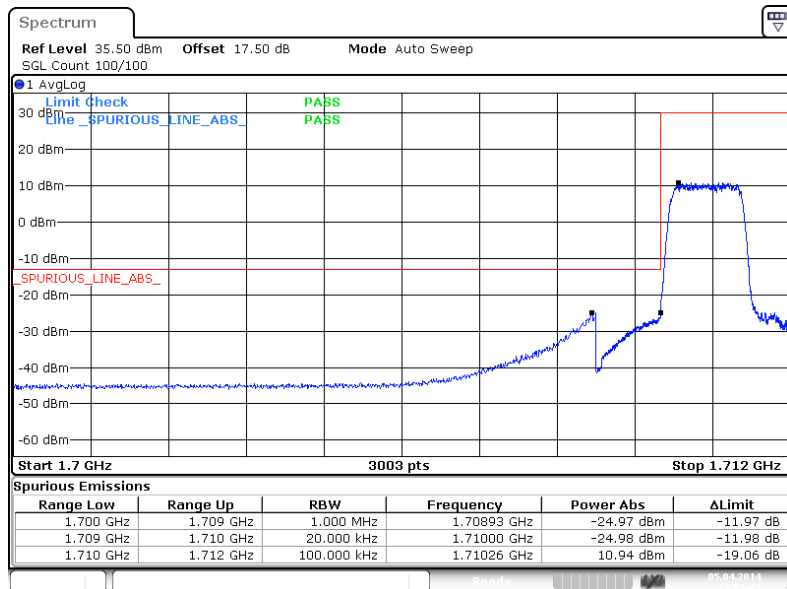



Higher Band Edge Plot for QPSK-RB Size 1, RB Offset 5

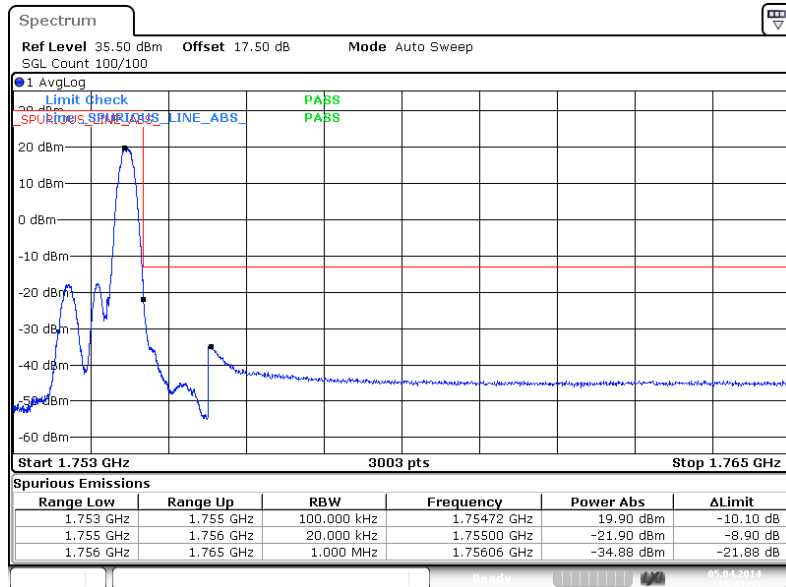

Higher Band Edge Plot for QPSK-RB Size 6, RB Offset 0

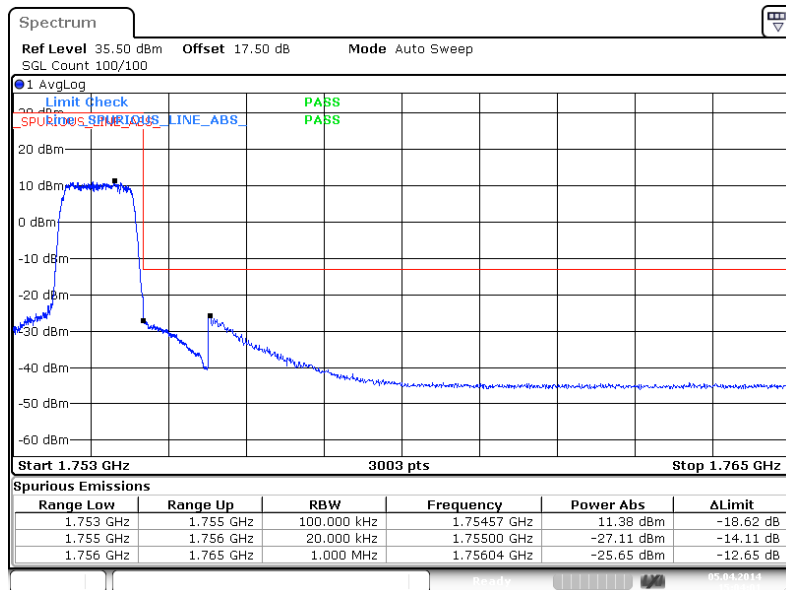



Band :	LTE Band 4	Band Width :	1.4MHz / 16QAM
--------	------------	--------------	----------------

Lower Band Edge Plot for 16QAM -RB Size 1, RB Offset 0

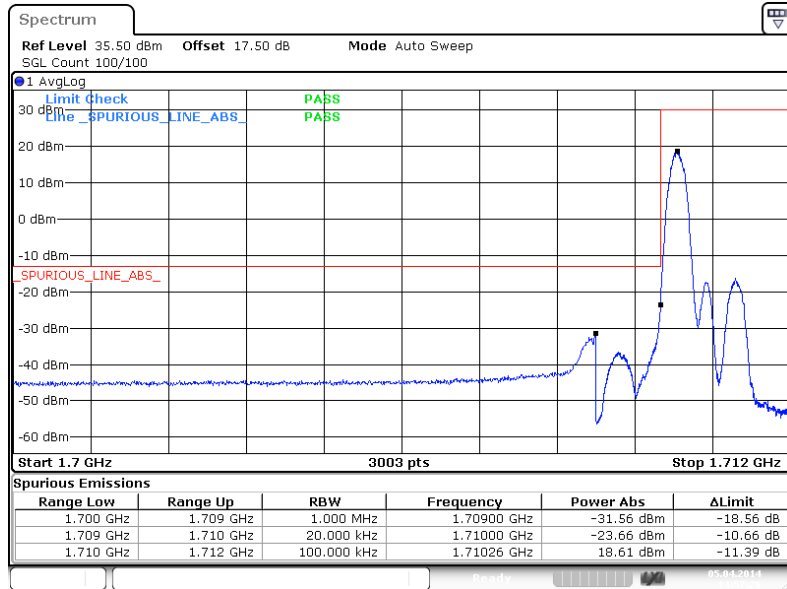

Lower Band Edge Plot for 16QAM-RB Size 6, RB Offset 0

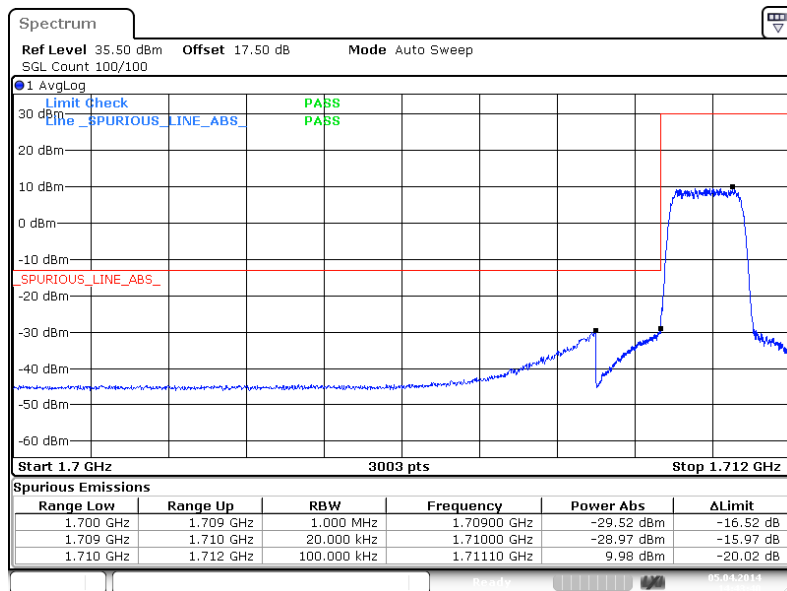



Higher Band Edge Plot for 16QAM-RB Size 1, RB Offset 5

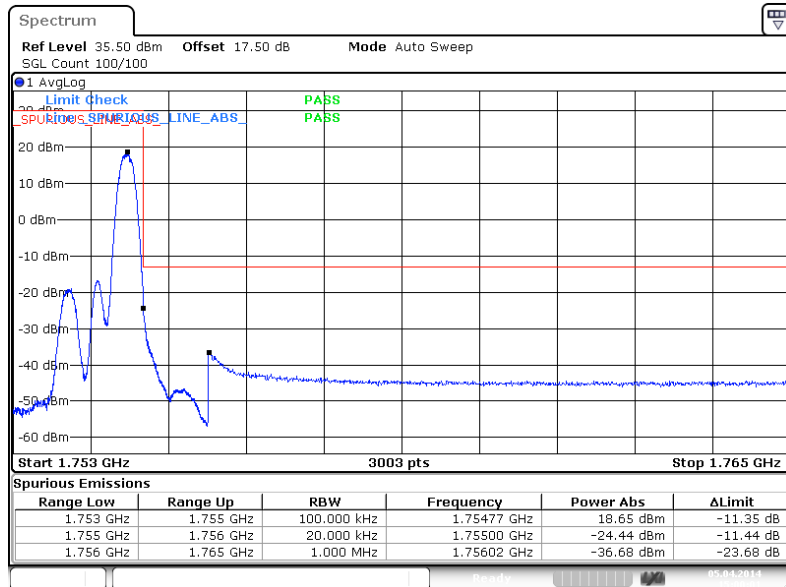

Higher Band Edge Plot for 16QAM-RB Size 6, RB Offset 0

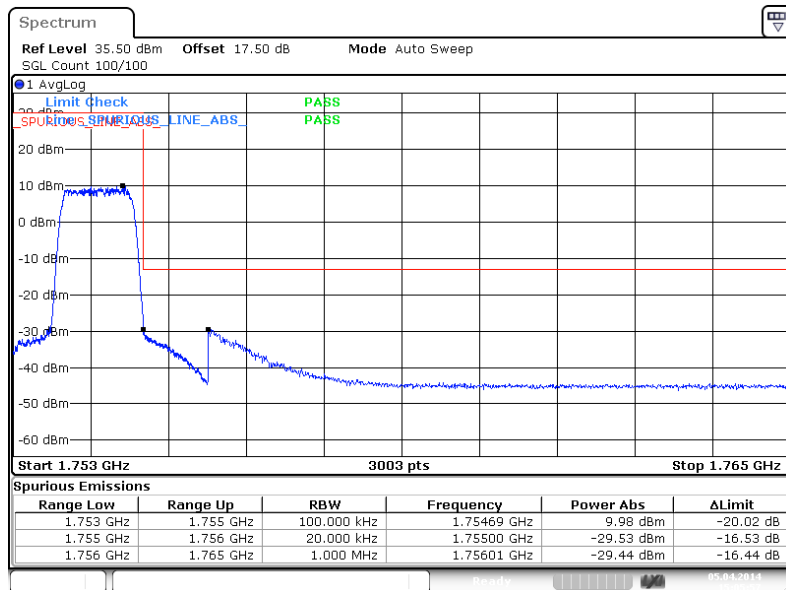



Band :	LTE Band 4	Band Width :	3MHz / QPSK
--------	------------	--------------	-------------

Lower Band Edge Plot for QPSK-RB Size 1, RB Offset 0

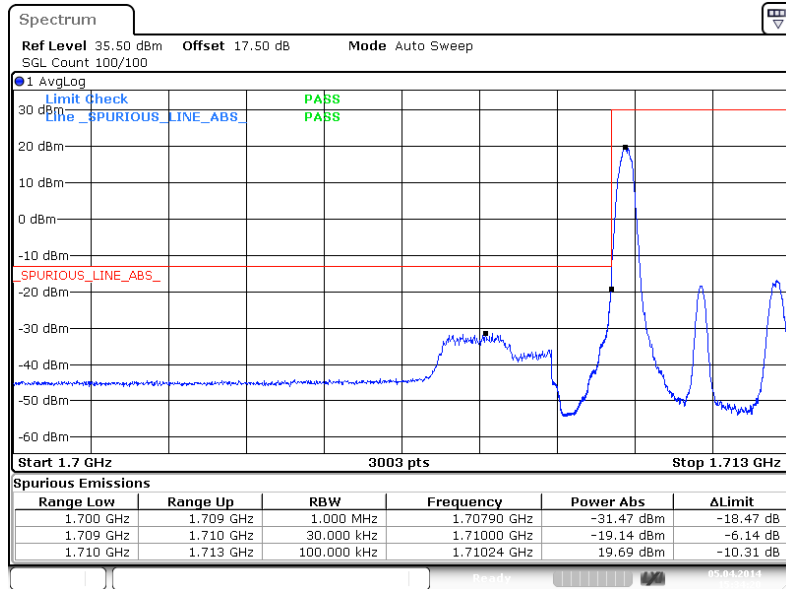

Lower Band Edge Plot for QPSK-RB Size 15, RB Offset 0

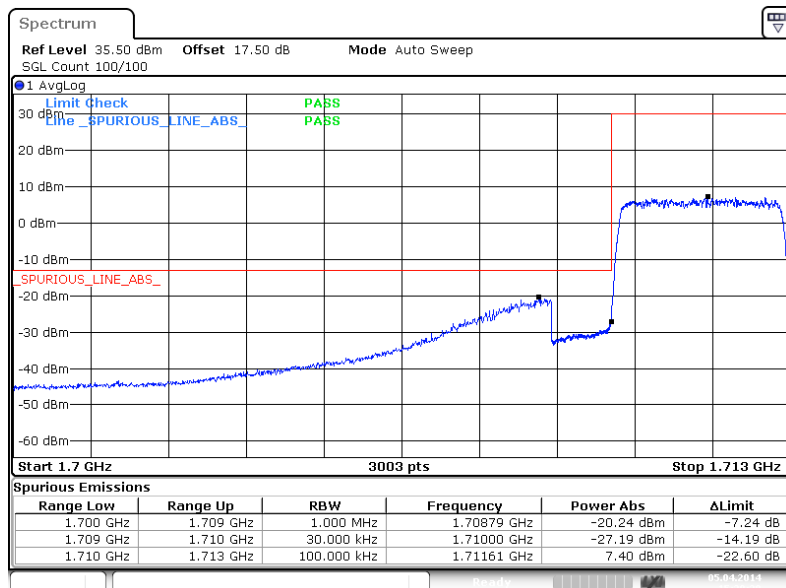



Higher Band Edge Plot for QPSK-RB Size 1, RB Offset 14

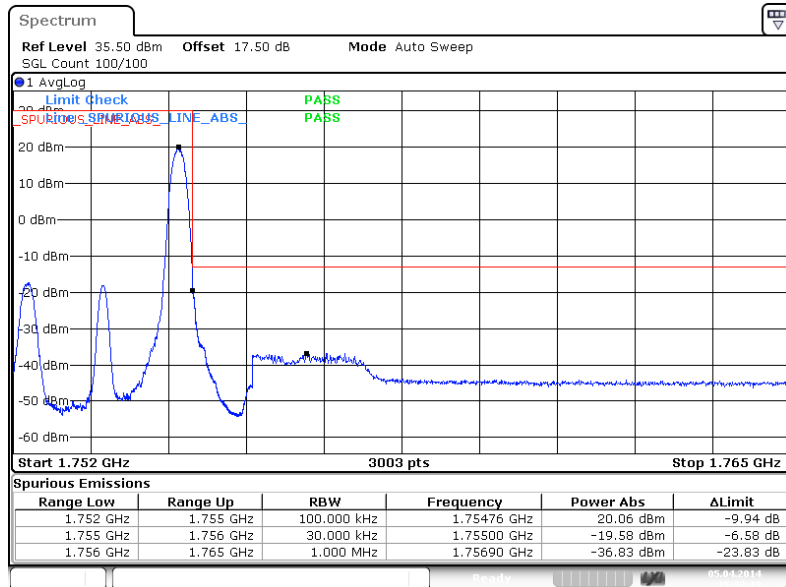

Higher Band Edge Plot for QPSK-RB Size 15, RB Offset 0

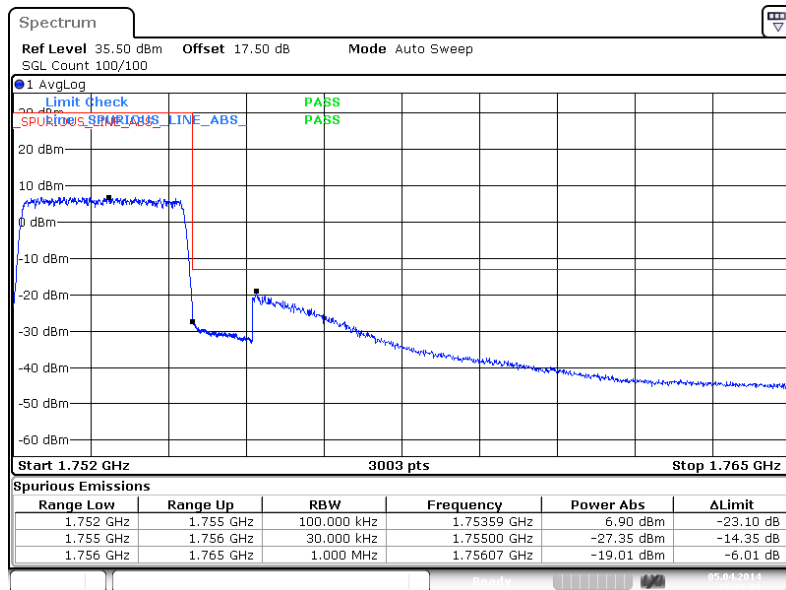



Band :	LTE Band 4	Band Width :	3MHz / 16QAM
--------	------------	--------------	--------------

Lower Band Edge Plot for 16QAM-RB Size 1, RB Offset 0

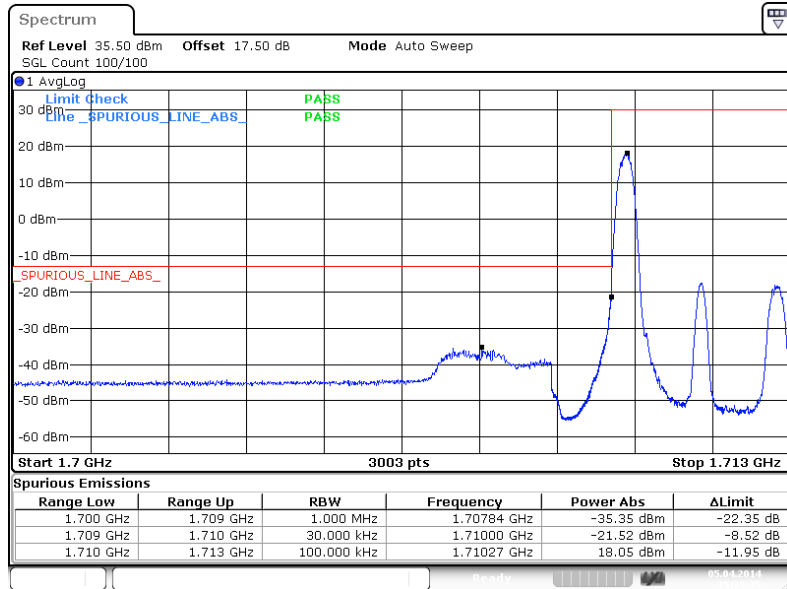

Lower Band Edge Plot for 16QAM-RB Size 15, RB Offset 0

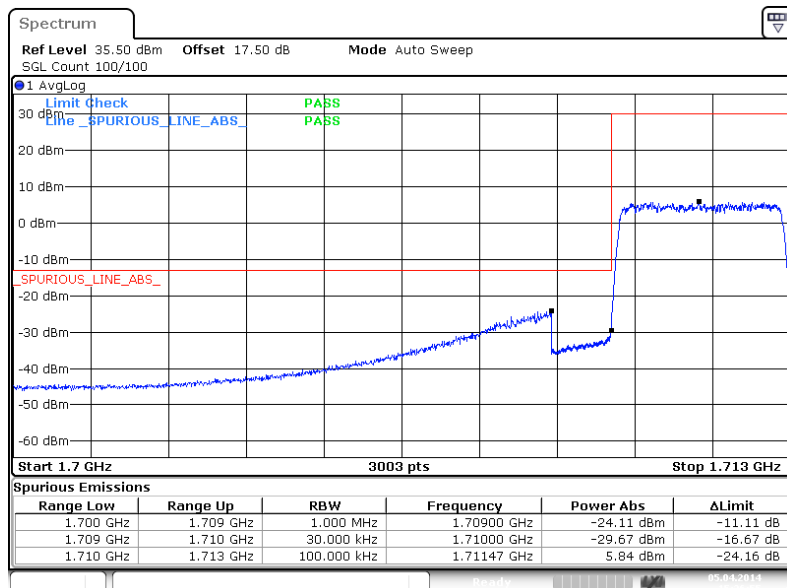



Higher Band Edge Plot for 16QAM-RB Size 1, RB Offset 14

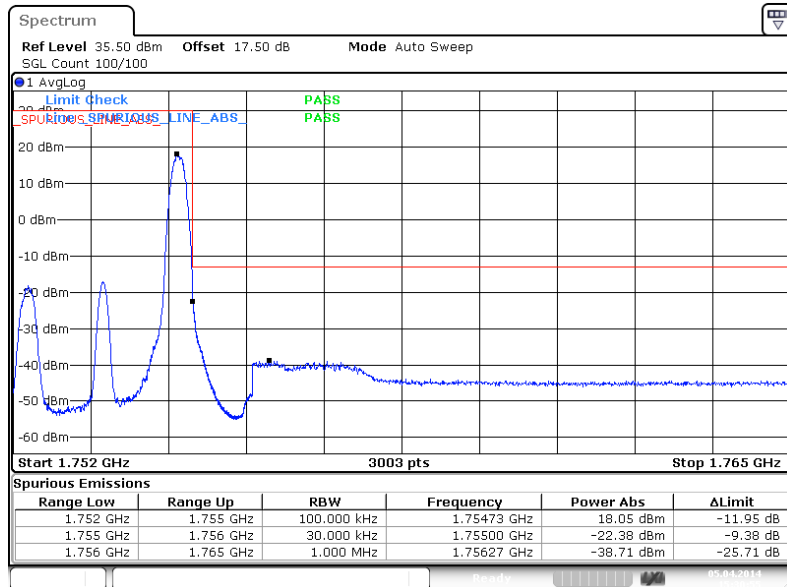

Higher Band Edge Plot for 16QAM-RB Size 15, RB Offset 0

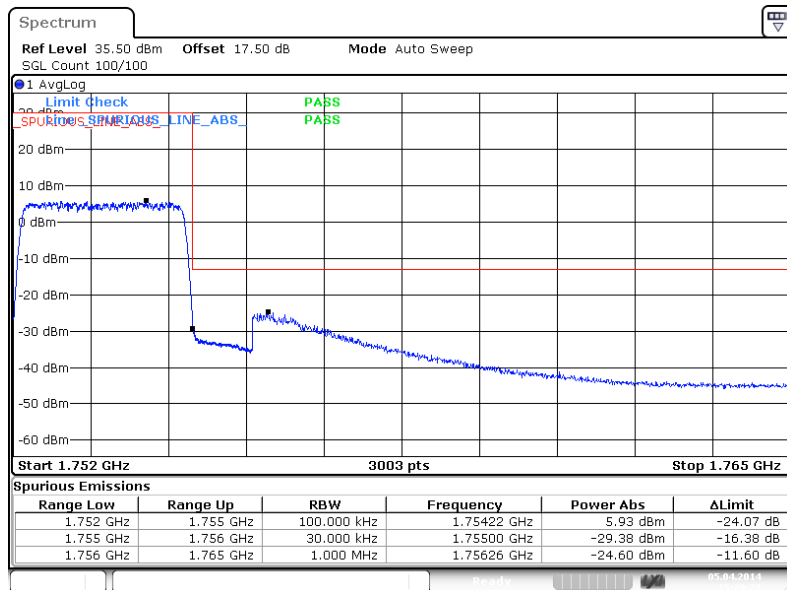



Band :	LTE Band 4	Band Width :	5MHz / QPSK
--------	------------	--------------	-------------

Lower Band Edge Plot for QPSK-RB Size 1, RB Offset 0

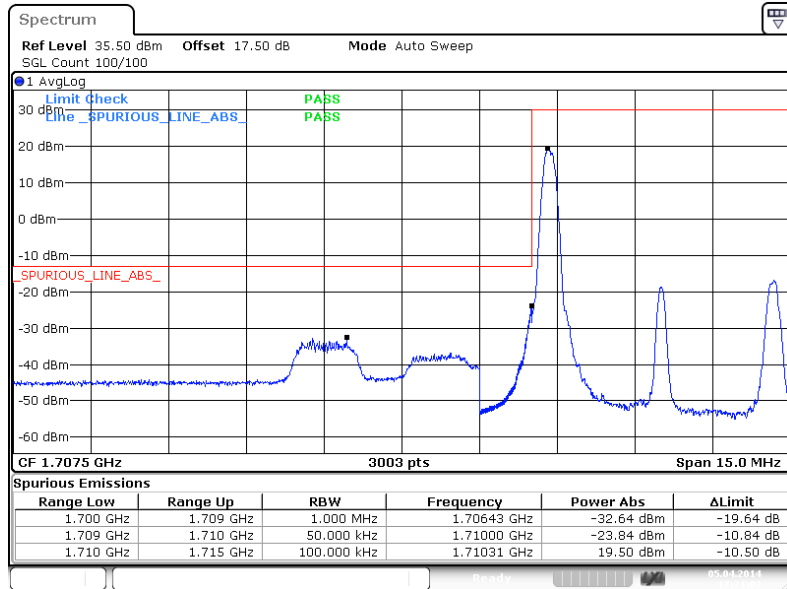

Lower Band Edge Plot for QPSK-RB Size 25, RB Offset 0

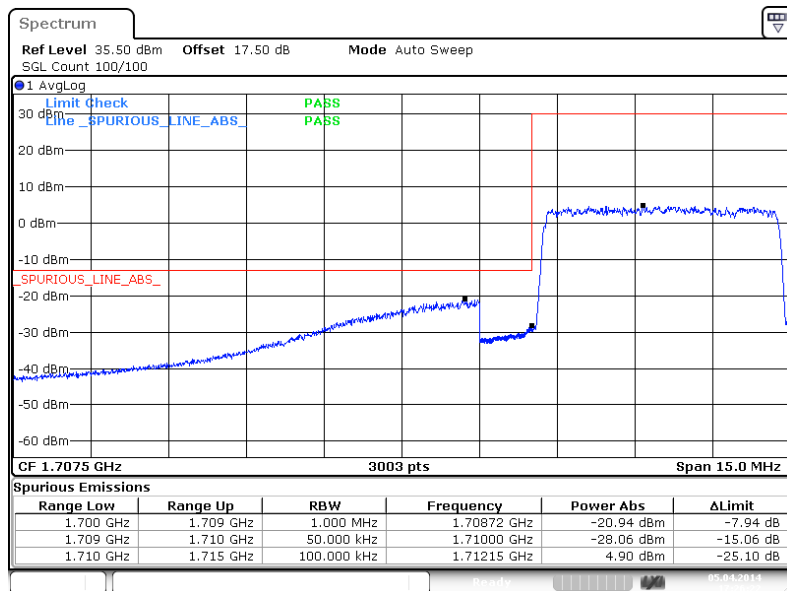



Higher Band Edge Plot for QPSK-RB Size 1, RB Offset 24

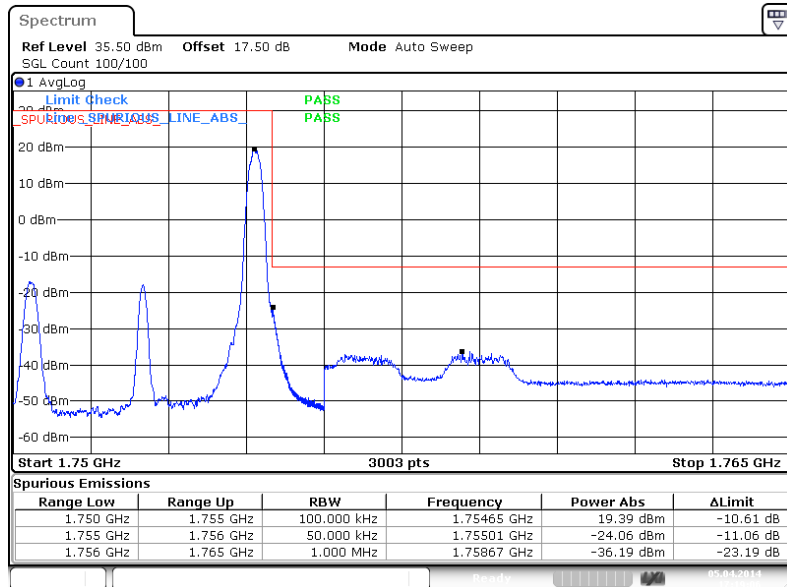

Higher Band Edge Plot for QPSK-RB Size 25, RB Offset 0

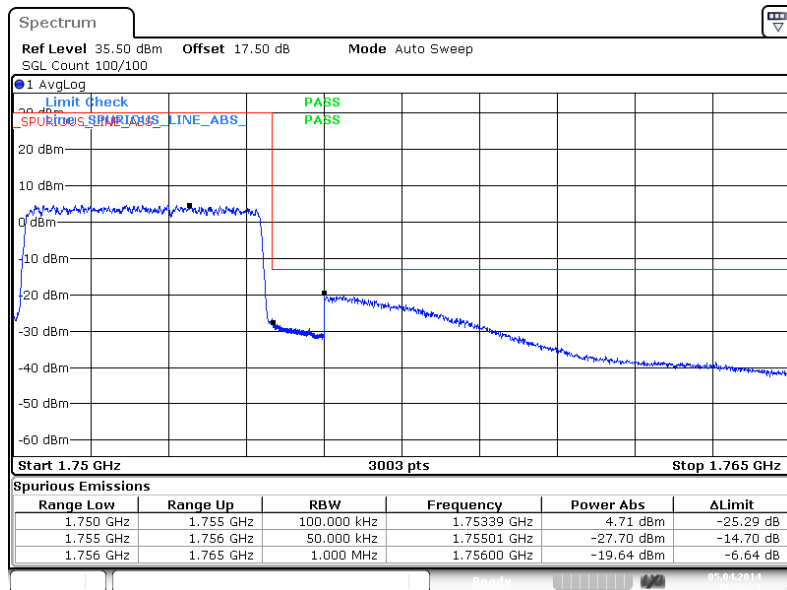



Band :	LTE Band 4	Band Width :	5MHz / 16QAM
--------	------------	--------------	--------------

Lower Band Edge Plot for 16QAM-RB Size 1, RB Offset 0

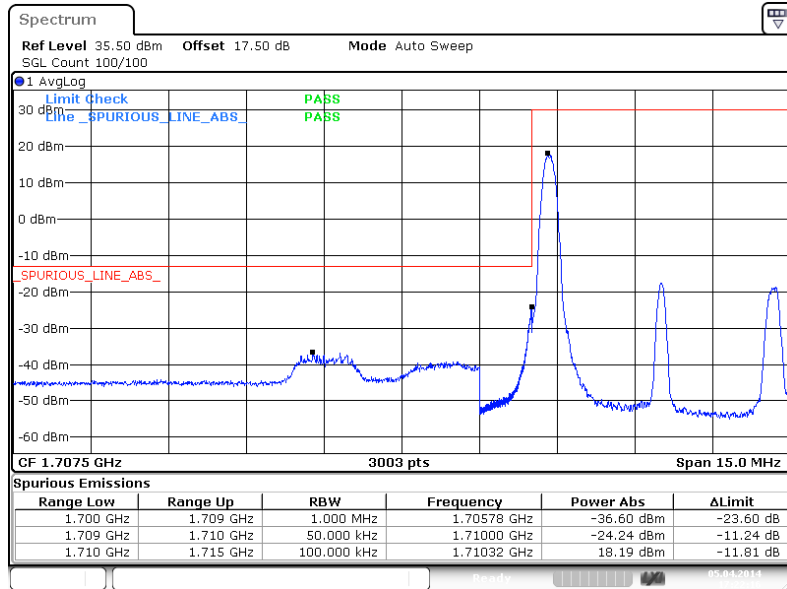

Lower Band Edge Plot for 16QAM-RB Size 25, RB Offset 0

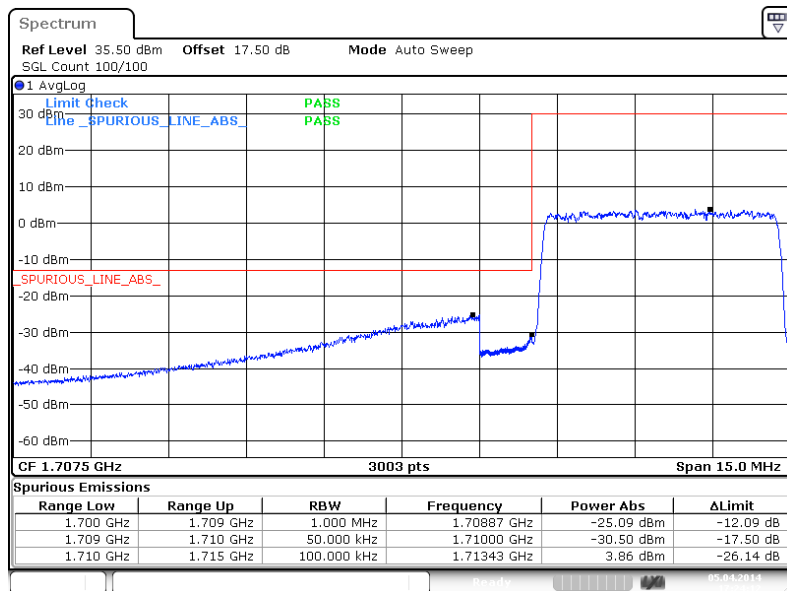



Higher Band Edge Plot for 16QAM-RB Size 1, RB Offset 24

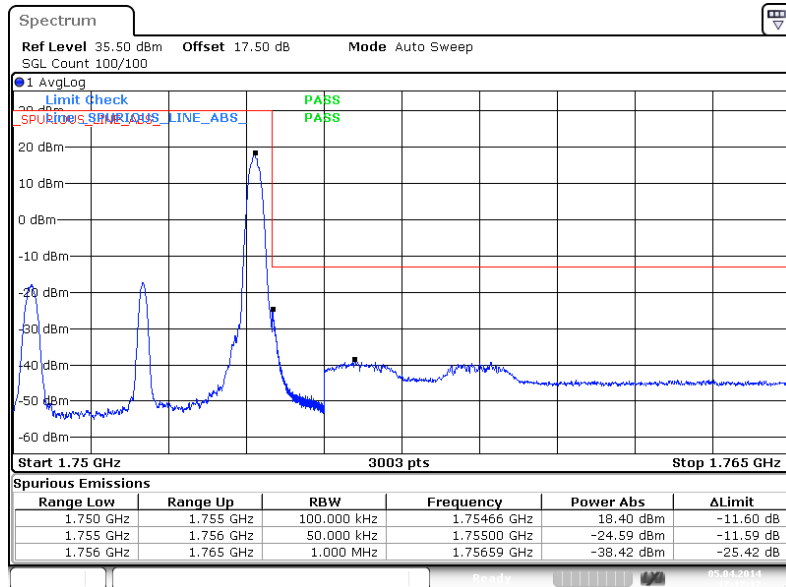

Higher Band Edge Plot for 16QAM-RB Size 25, RB Offset 0

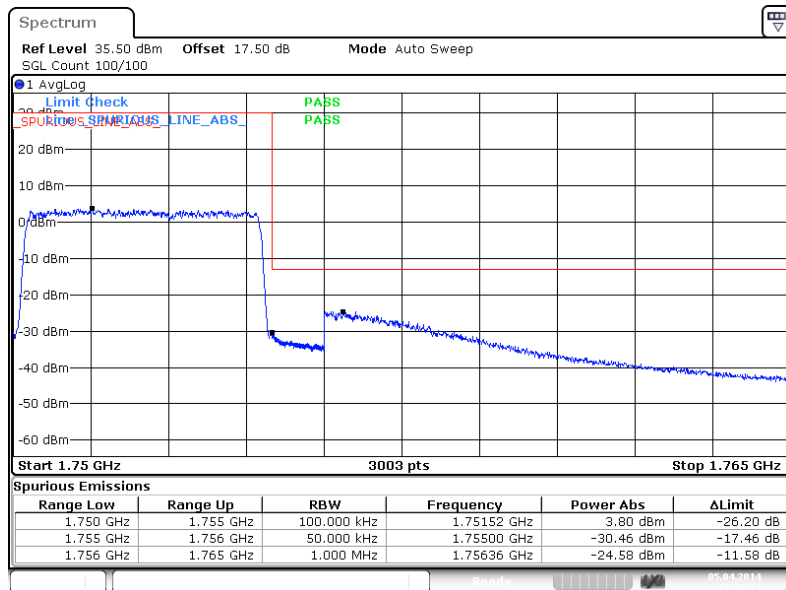



Band :	LTE Band 4	Band Width :	10MHz / QPSK
--------	------------	--------------	--------------

Lower Band Edge Plot for QPSK-RB Size 1, RB Offset 0

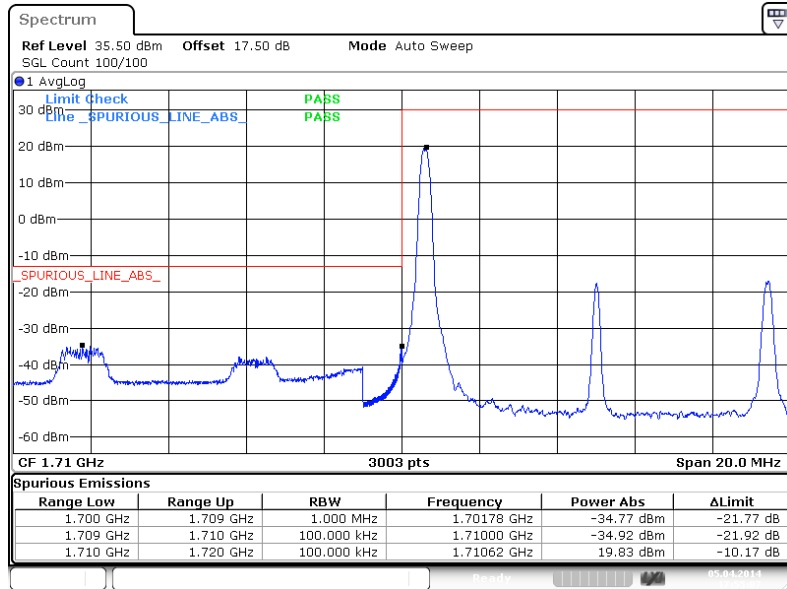

Lower Band Edge Plot for QPSK-RB Size 50, RB Offset 0

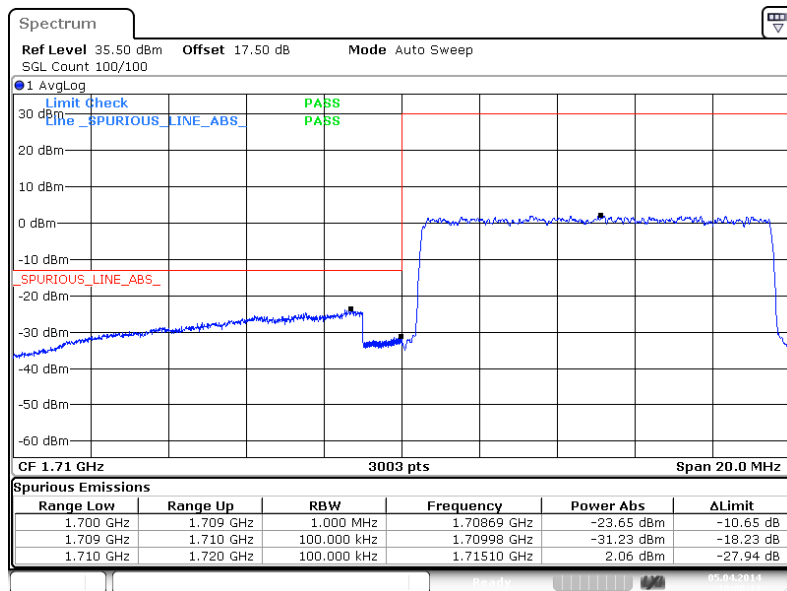



Higher Band Edge Plot for QPSK-RB Size 1, RB Offset 49

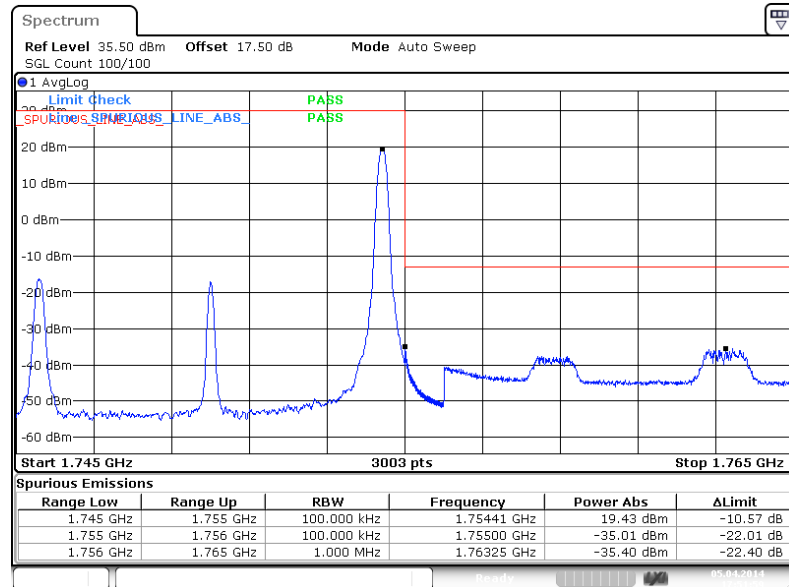

Higher Band Edge Plot for QPSK-RB Size 50, RB Offset 0

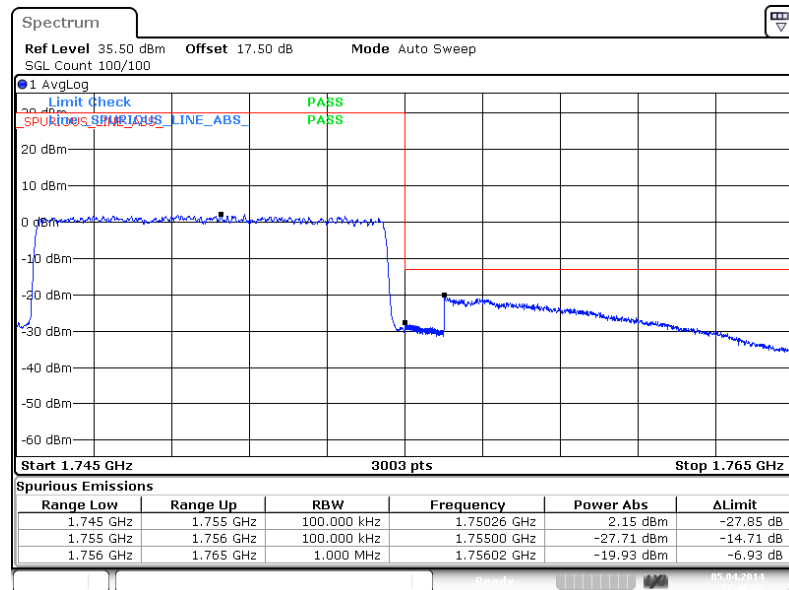



Band :	LTE Band 4	Band Width :	10MHz / 16QAM
--------	------------	--------------	---------------

Lower Band Edge Plot for 16QAM-RB Size 1, RB Offset 0

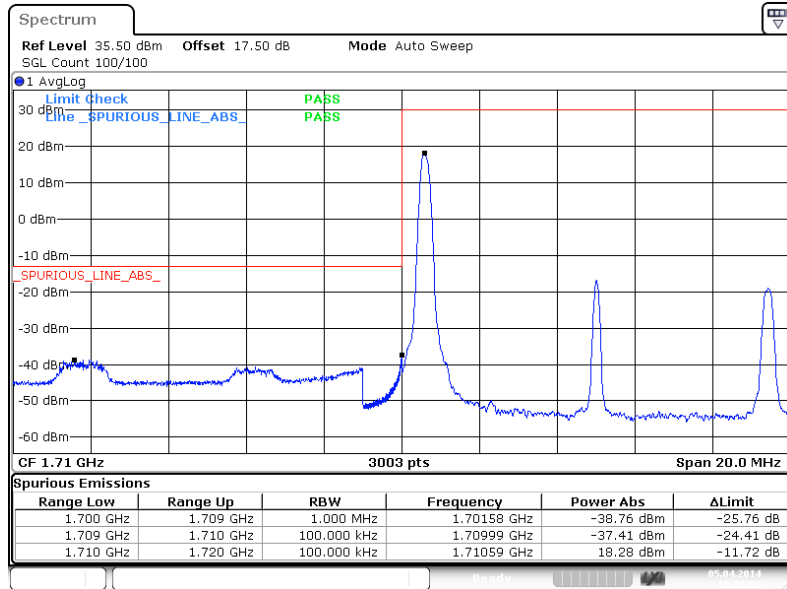

Lower Band Edge Plot for 16QAM-RB Size 50, RB Offset 0

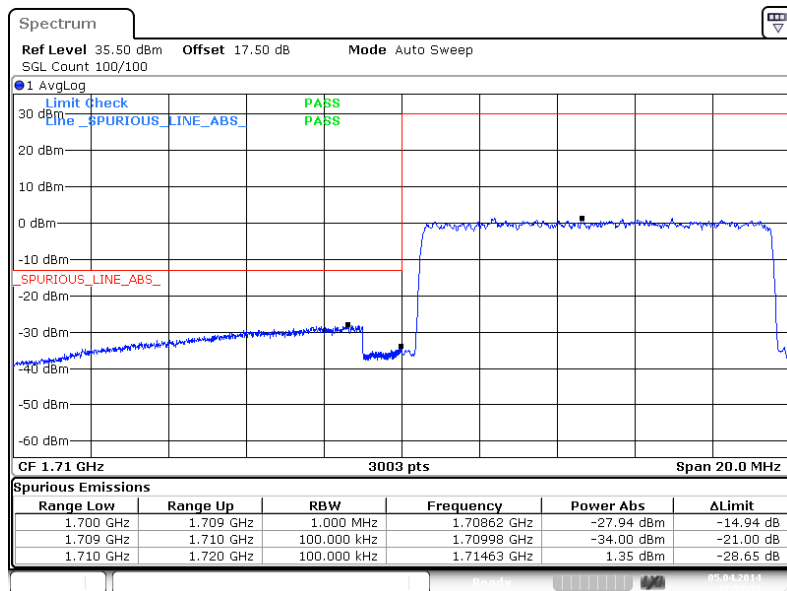



Higher Band Edge Plot for 16QAM-RB Size 1, RB Offset 49

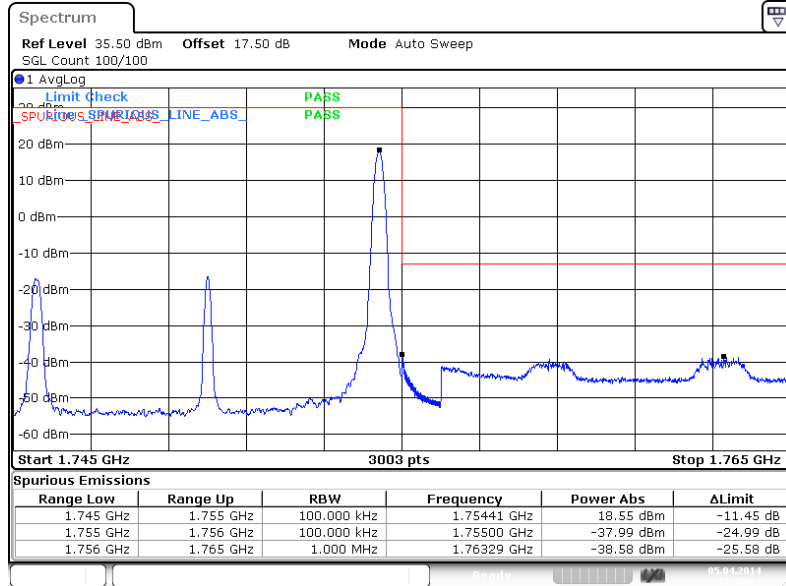

Higher Band Edge Plot for 16QAM-RB Size 50, RB Offset 0

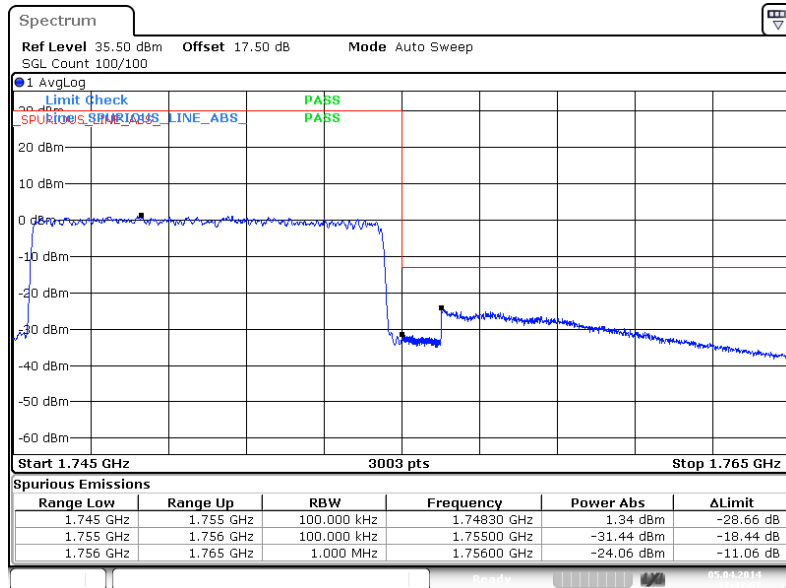



Band :	LTE Band 4	Band Width :	15MHz / QPSK
--------	------------	--------------	--------------

Lower Band Edge Plot for QPSK-RB Size 1, RB Offset 0

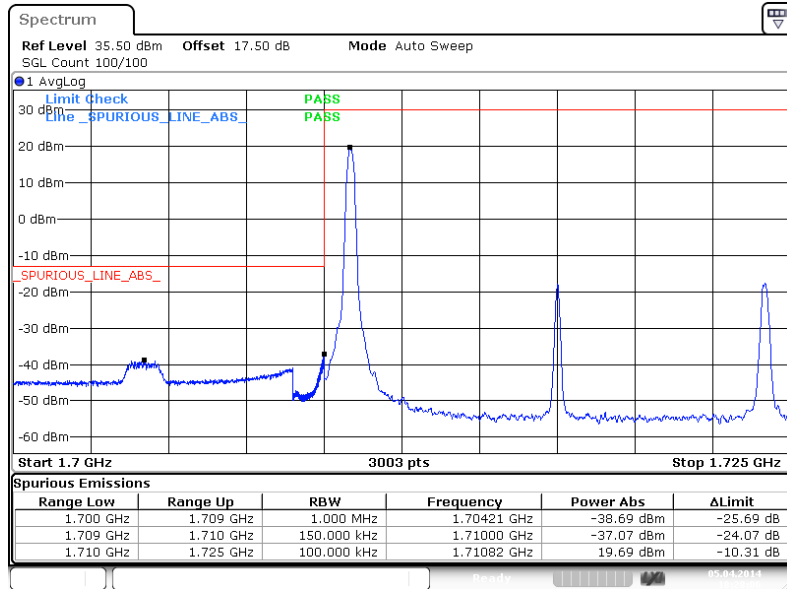

Lower Band Edge Plot for QPSK-RB Size 75, RB Offset 0

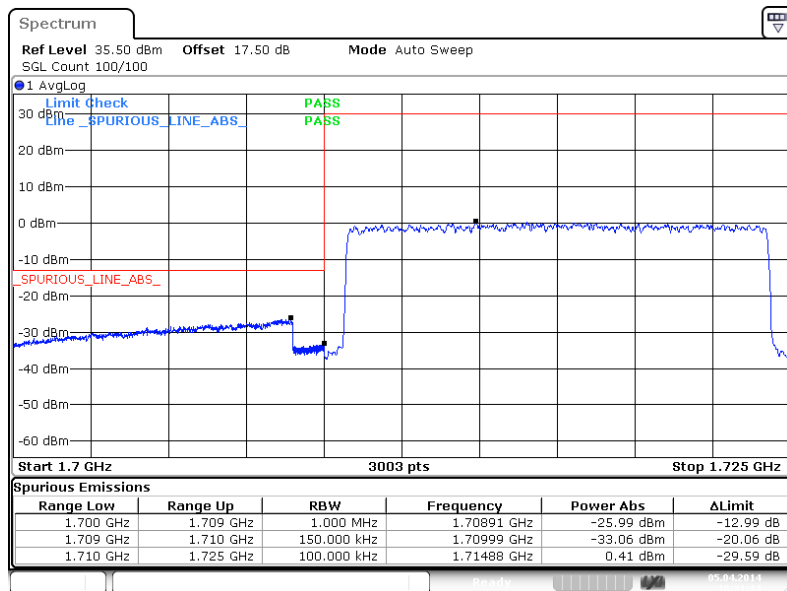



Higher Band Edge Plot for QPSK-RB Size 1, RB Offset 74

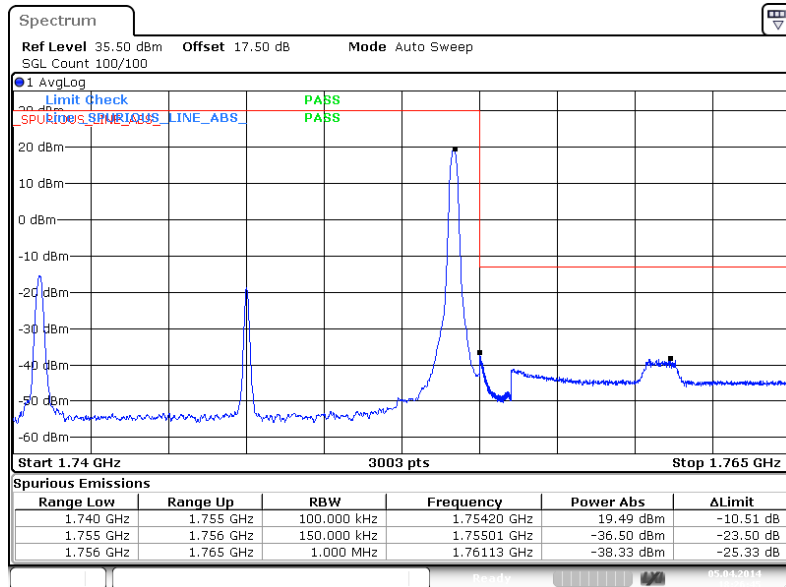

Higher Band Edge Plot for QPSK-RB Size 75, RB Offset 0

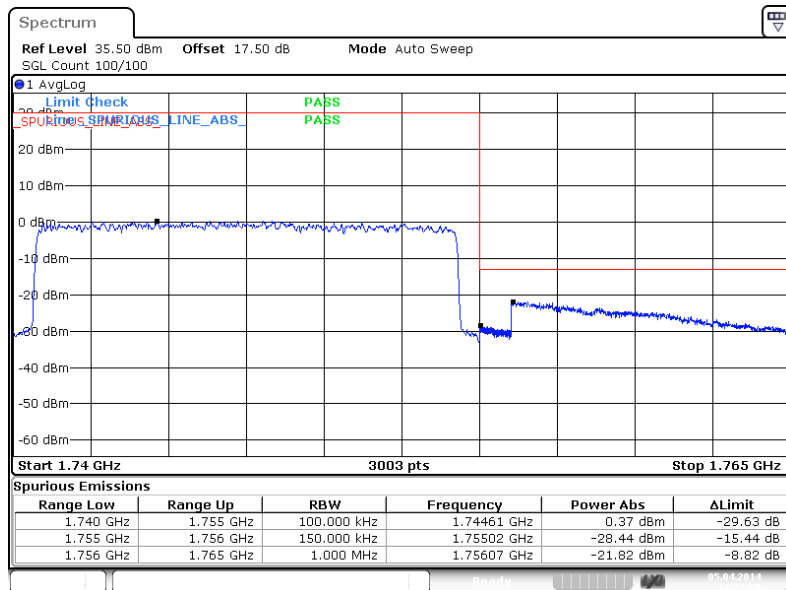



Band :	LTE Band 4	Band Width :	15MHz / 16QAM
---------------	------------	---------------------	---------------

Lower Band Edge Plot for 16QAM-RB Size 1, RB Offset 0

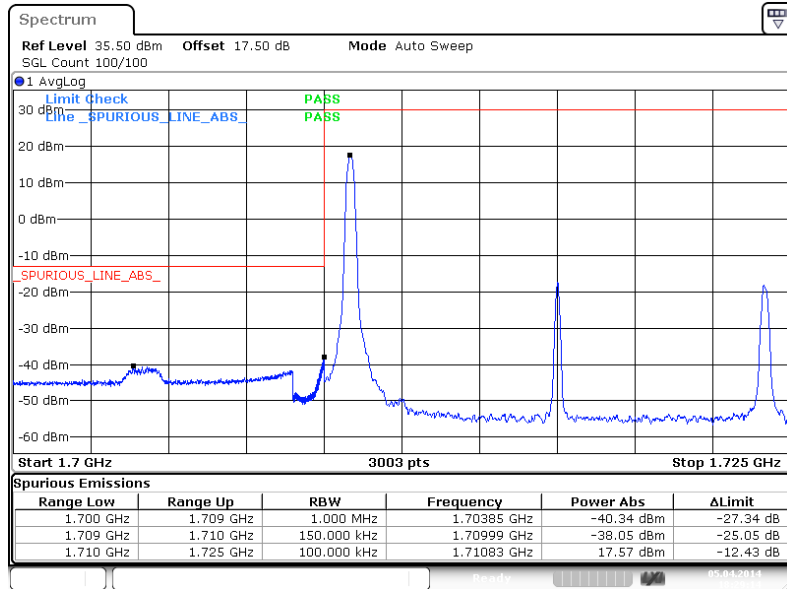

Lower Band Edge Plot for 16QAM-RB Size 75, RB Offset 0

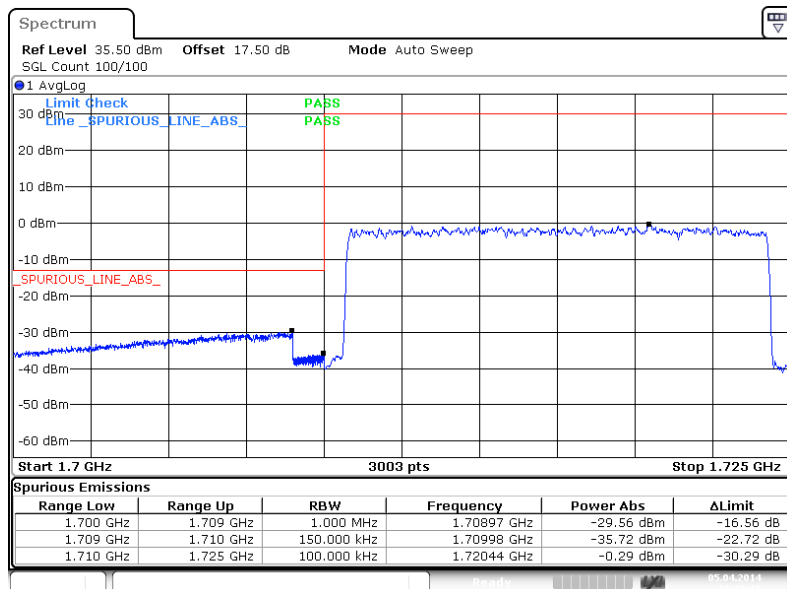



Higher Band Edge Plot for 16QAM-RB Size 1, RB Offset 74

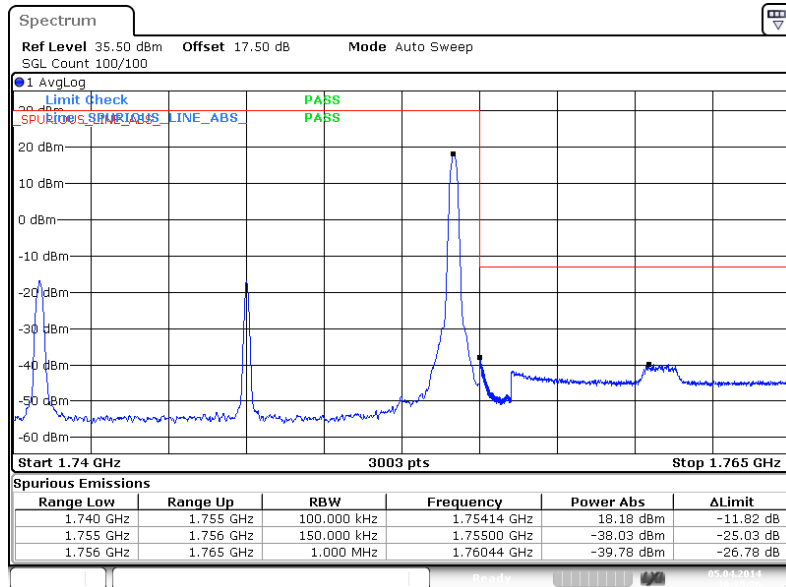

Higher Band Edge Plot for 16QAM-RB Size 75, RB Offset 0

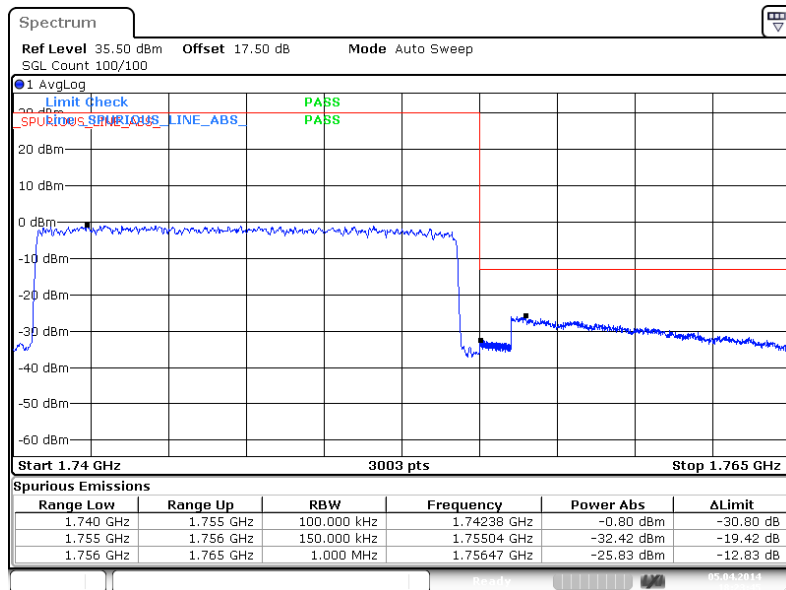



Band :	LTE Band 4	Band Width :	20MHz / QPSK
--------	------------	--------------	--------------

Lower Band Edge Plot for QPSK-RB Size 1, RB Offset 0

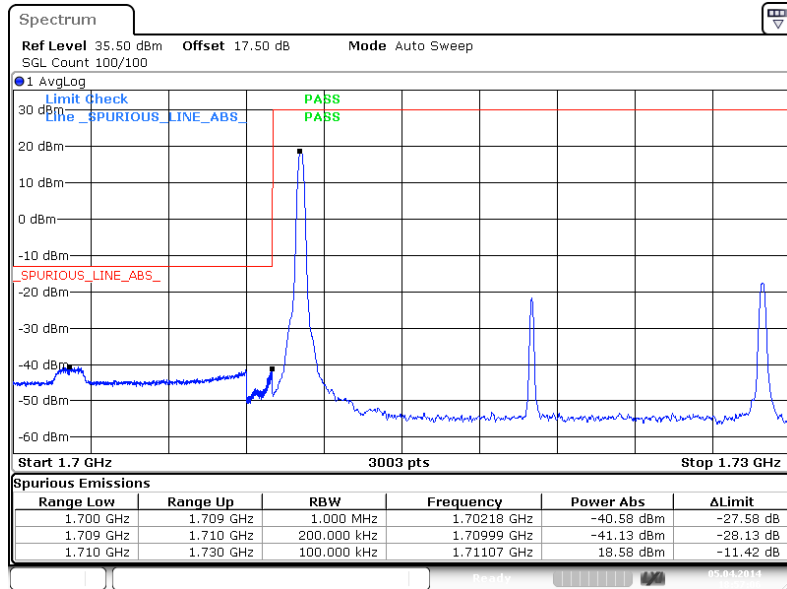

Lower Band Edge Plot for QPSK-RB Size 100, RB Offset 0

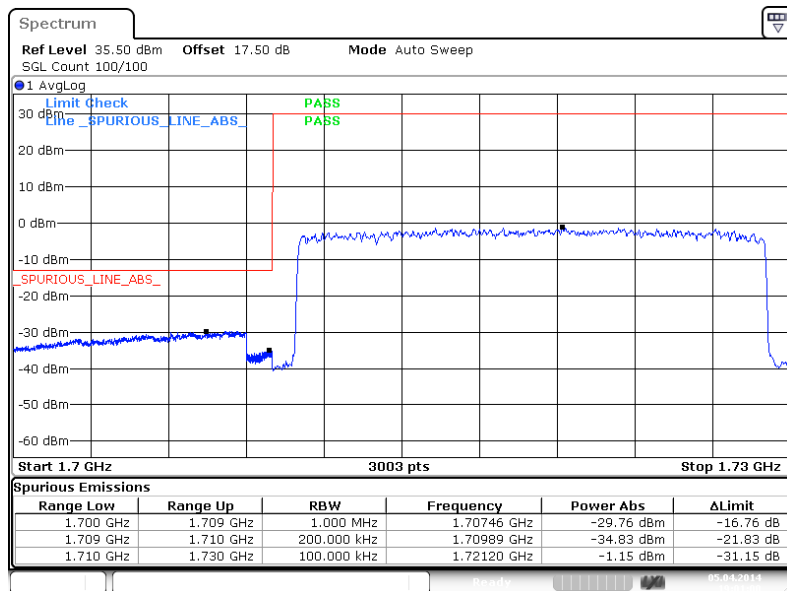



Higher Band Edge Plot for QPSK-RB Size 1, RB Offset 99

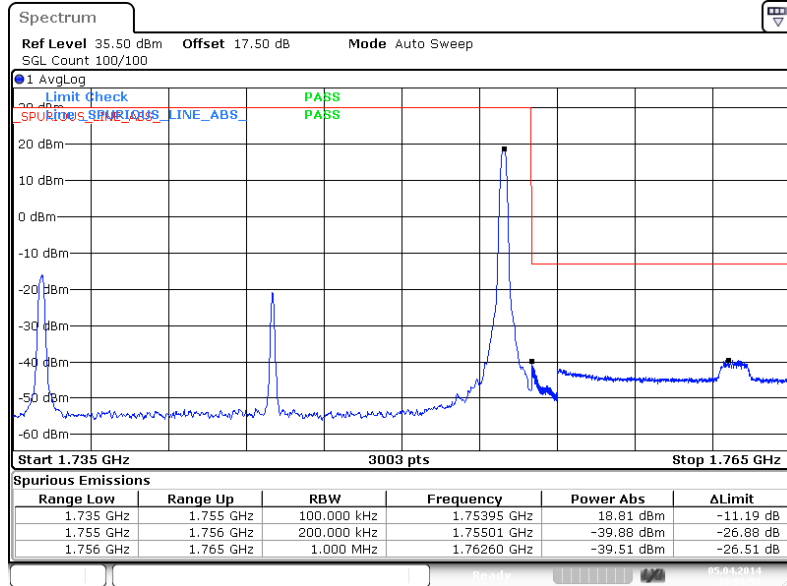

Higher Band Edge Plot for QPSK-RB Size 100, RB Offset 0

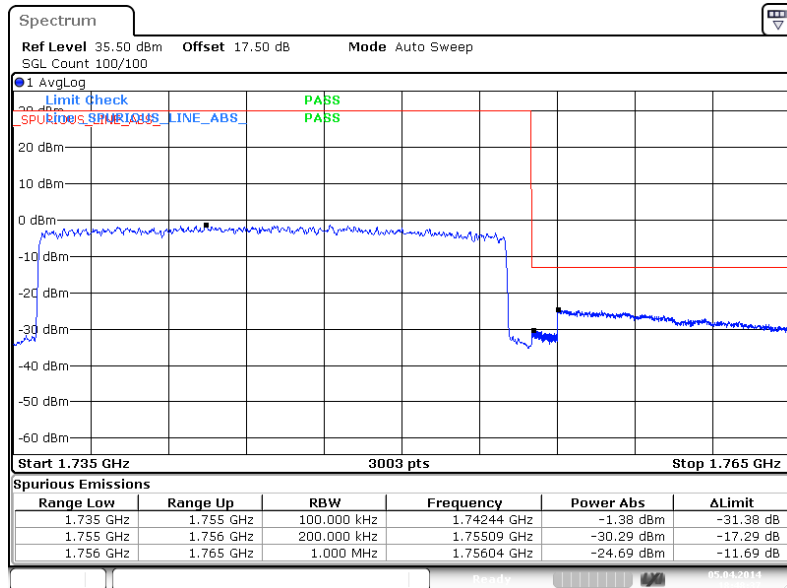



Band :	LTE Band 4	Band Width :	20MHz / 16QAM
--------	------------	--------------	---------------

Lower Band Edge Plot for 16QAM-RB Size 1, RB Offset 0

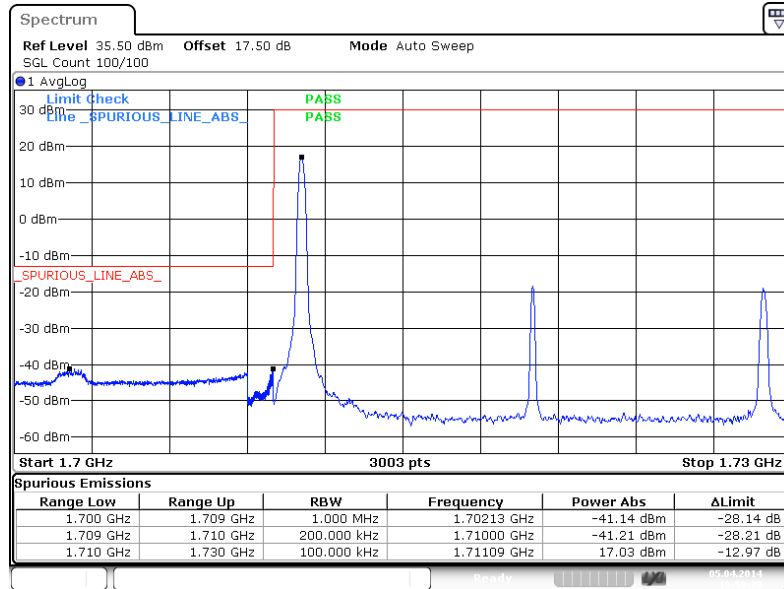

Lower Band Edge Plot for 16QAM-RB Size 100, RB Offset 0

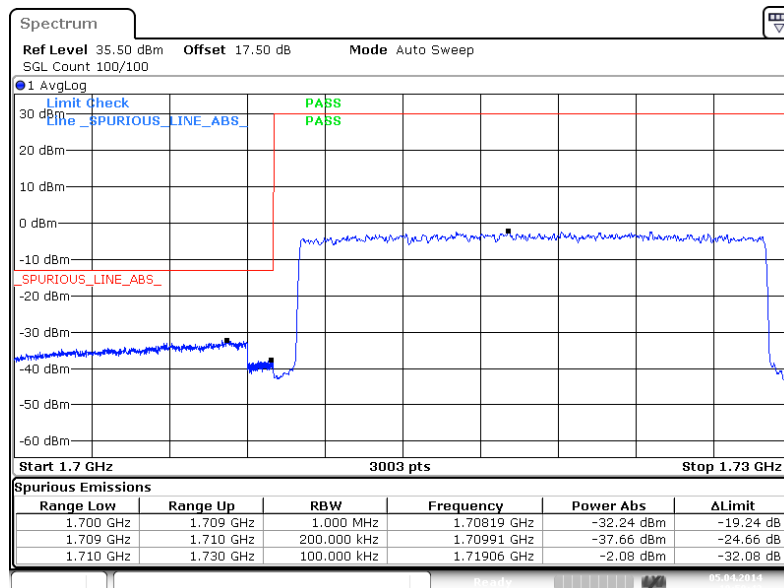



Higher Band Edge Plot for 16QAM-RB Size 1, RB Offset 99

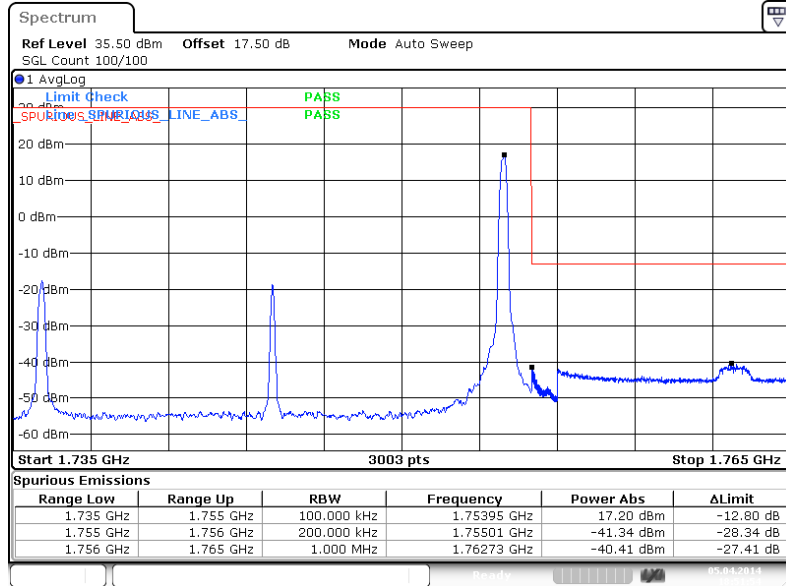

Higher Band Edge Plot for 16QAM-RB Size 100, RB Offset 0

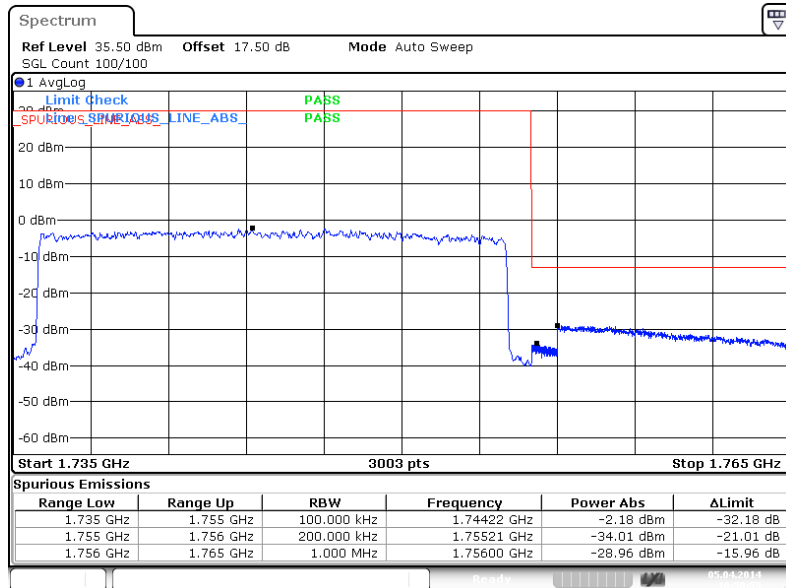



Band :	LTE Band 7	Band Width :	5MHz / QPSK
--------	------------	--------------	-------------

Lower Band Edge Plot for QPSK-RB Size 1, RB Offset 0

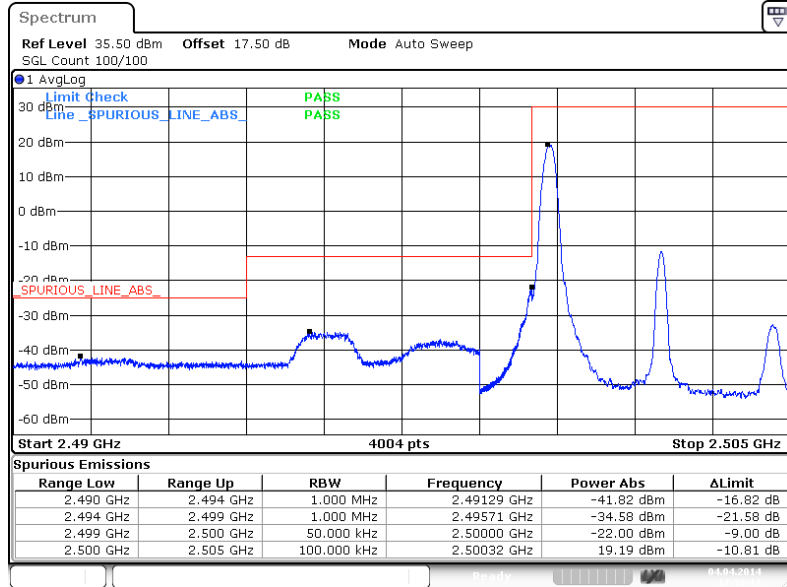

Lower Band Edge Plot for QPSK-RB Size 25, RB Offset 0

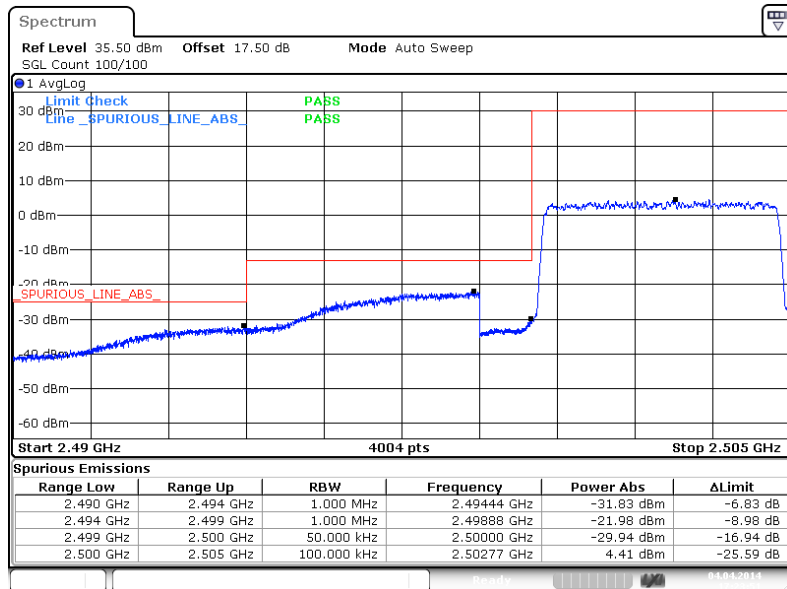



Higher Band Edge Plot for QPSK-RB Size 1, RB Offset 24

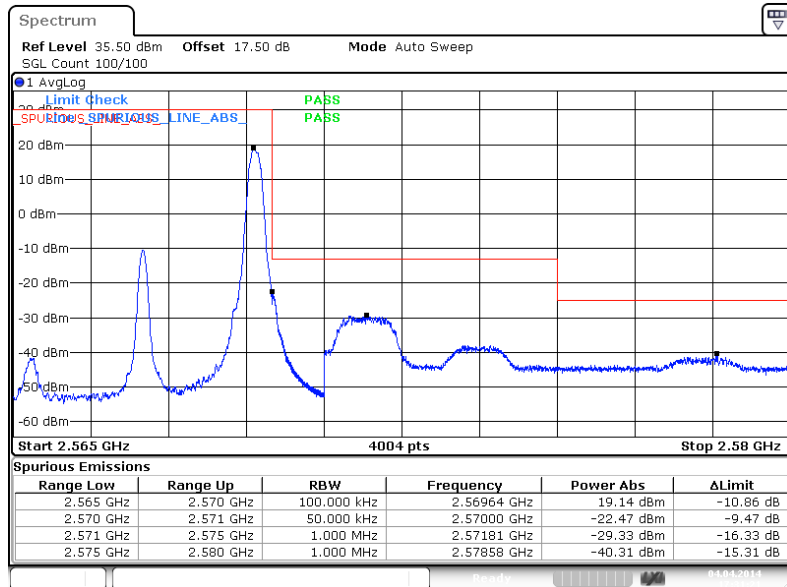

Higher Band Edge Plot for QPSK-RB Size 25, RB Offset 0

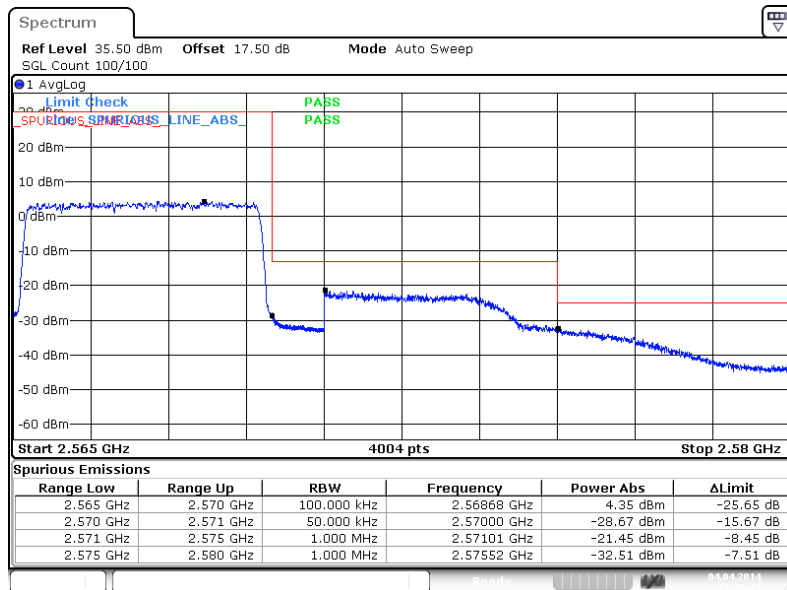



Band :	LTE Band 7	Band Width :	5MHz / 16QAM
--------	------------	--------------	--------------

Lower Band Edge Plot for 16QAM-RB Size 1, RB Offset 0

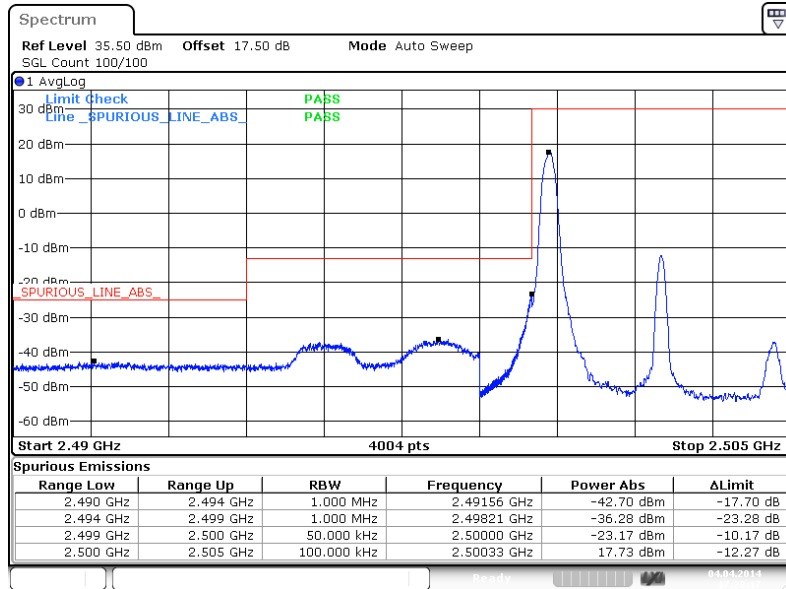

Lower Band Edge Plot for 16QAM-RB Size 25, RB Offset 0

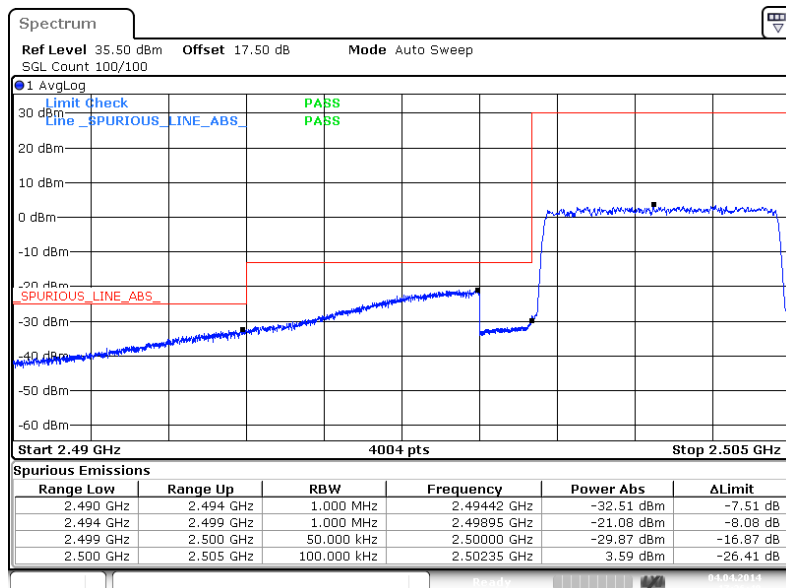



Higher Band Edge Plot for 16QAM-RB Size 1, RB Offset 24

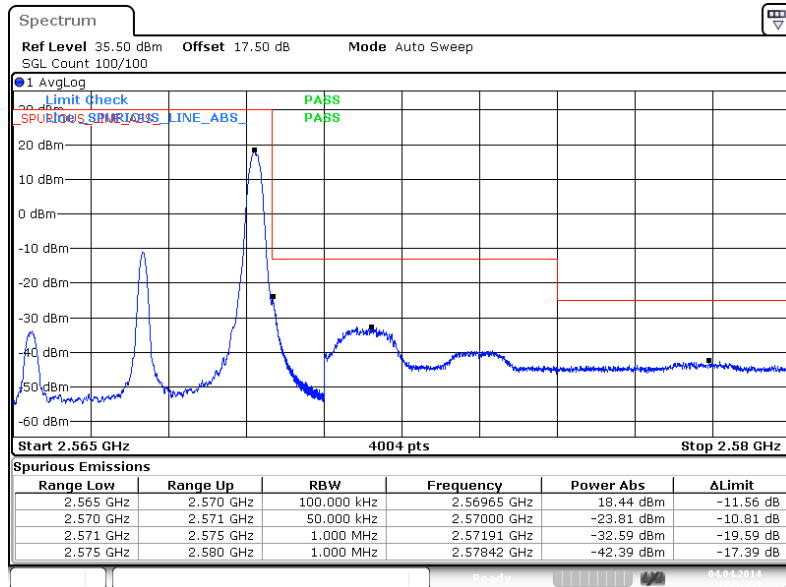

Higher Band Edge Plot for 16QAM-RB Size 25, RB Offset 0

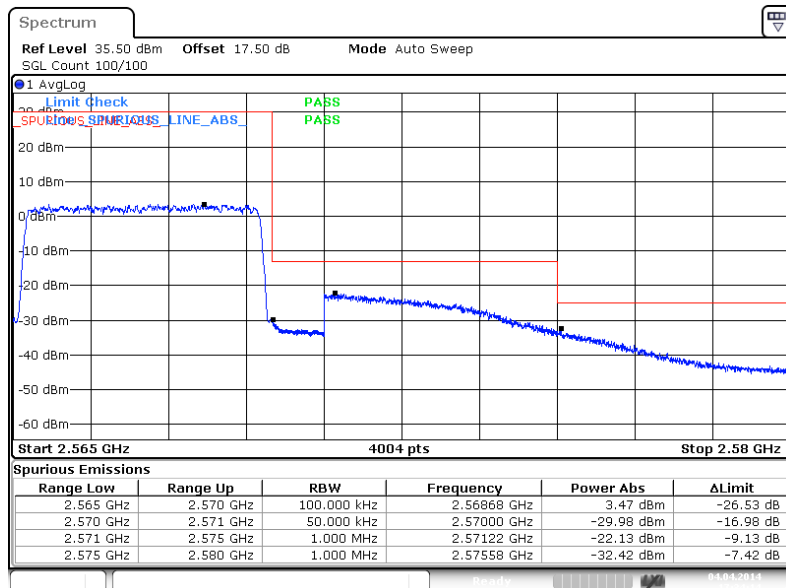



Band :	LTE Band 7	Band Width :	10MHz / QPSK
--------	------------	--------------	--------------

Lower Band Edge Plot for QPSK-RB Size 1, RB Offset 0

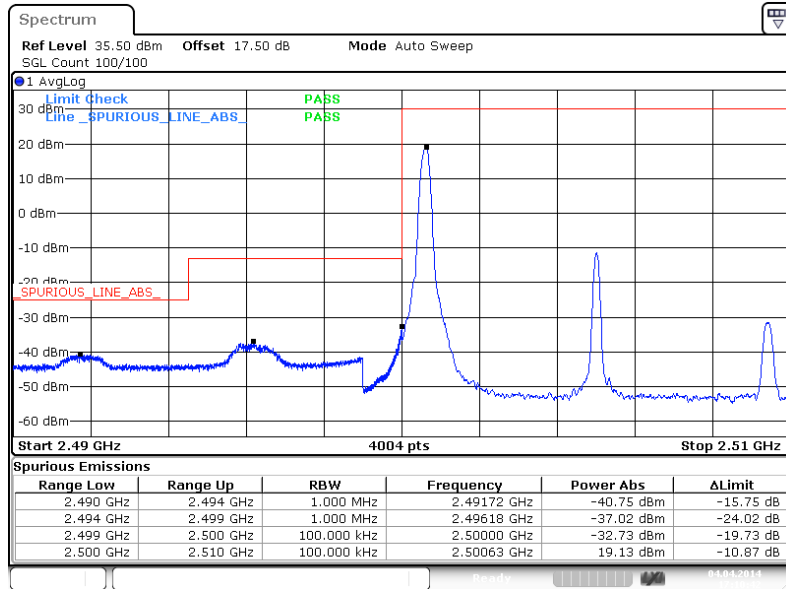

Lower Band Edge Plot for QPSK-RB Size 50, RB Offset 0

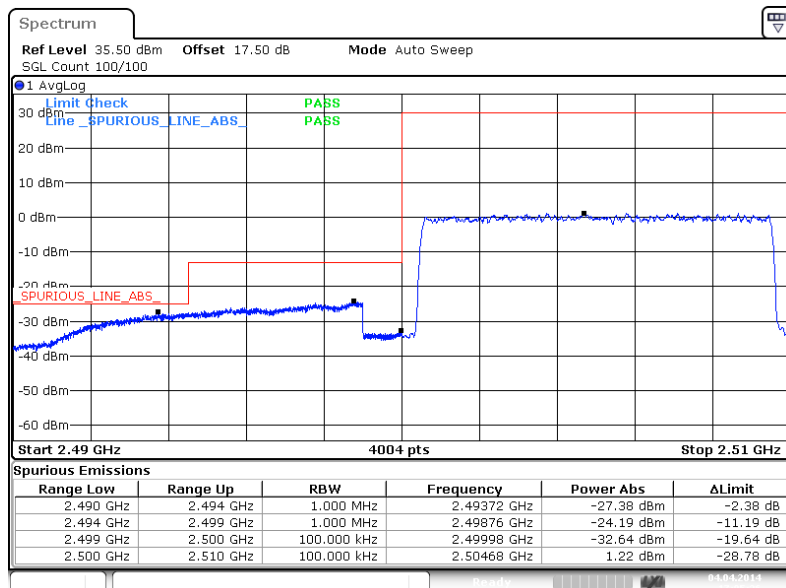



Higher Band Edge Plot for QPSK-RB Size 1, RB Offset 49

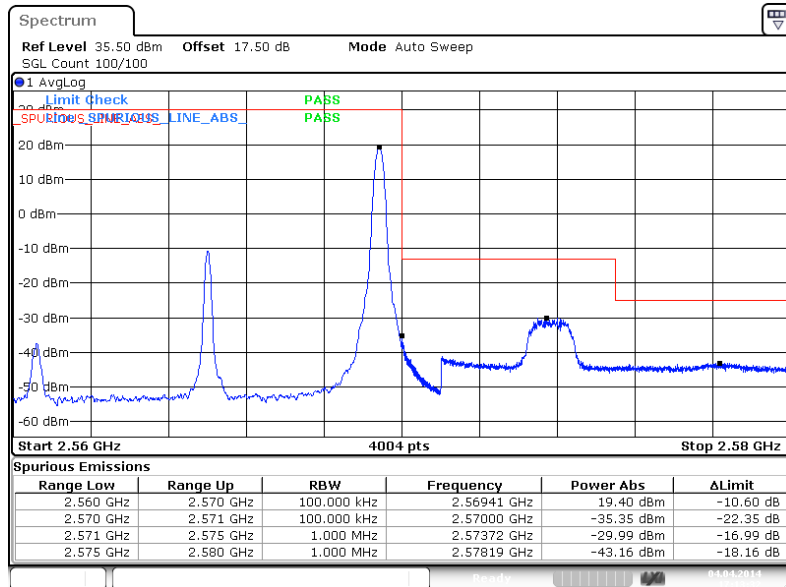

Higher Band Edge Plot for QPSK-RB Size 50, RB Offset 0

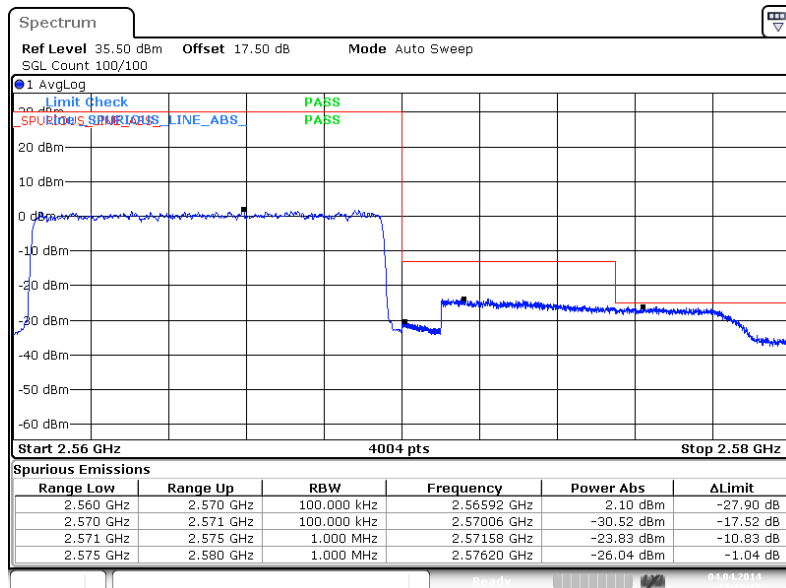



Band :	LTE Band 7	Band Width :	10MHz / 16QAM
--------	------------	--------------	---------------

Lower Band Edge Plot for 16QAM-RB Size 1, RB Offset 0

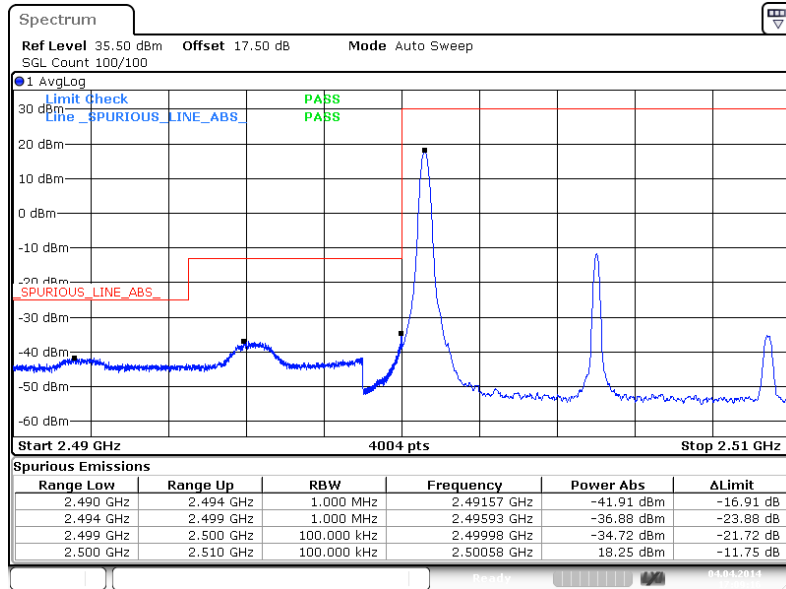

Lower Band Edge Plot for 16QAM-RB Size 50, RB Offset 0

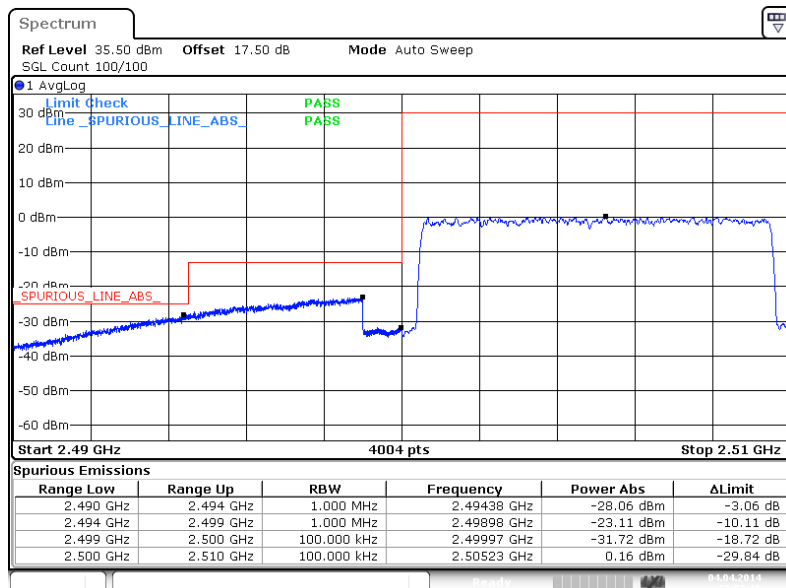



Higher Band Edge Plot for 16QAM-RB Size 1, RB Offset 49

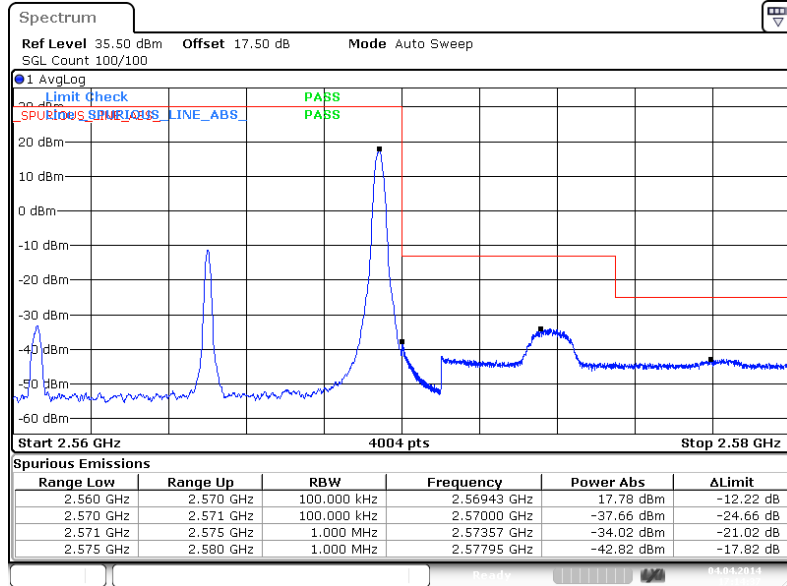

Higher Band Edge Plot for 16QAM-RB Size 50, RB Offset 0

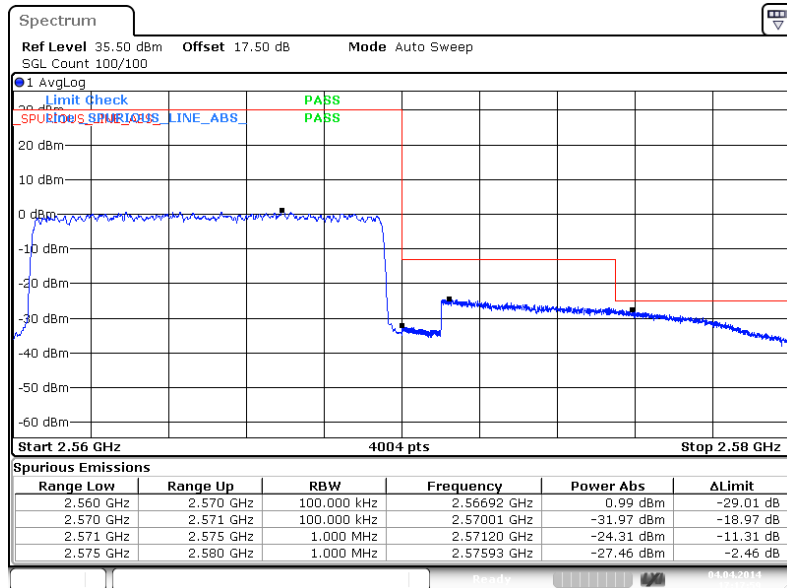



Band :	LTE Band 7	Band Width :	15MHz / QPSK
--------	------------	--------------	--------------

Lower Band Edge Plot for QPSK-RB Size 1, RB Offset 0

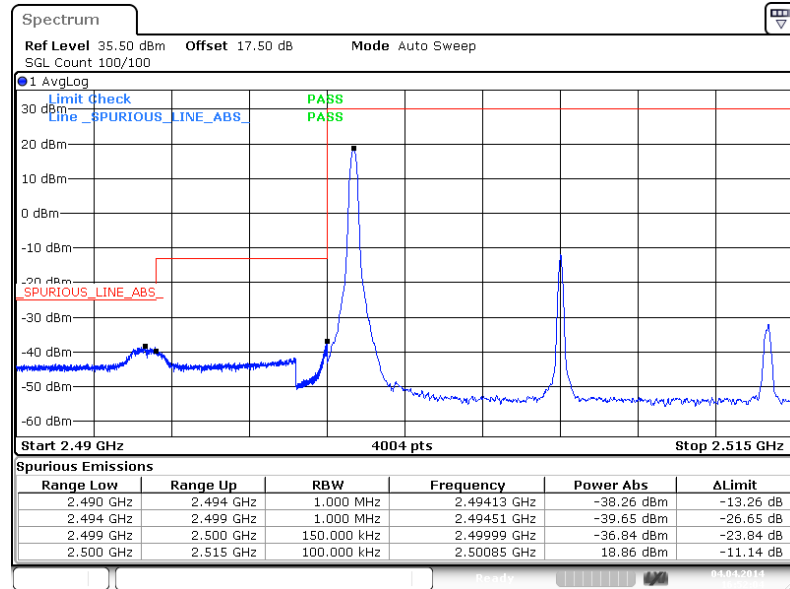

Lower Band Edge Plot for QPSK-RB Size 75, RB Offset 0

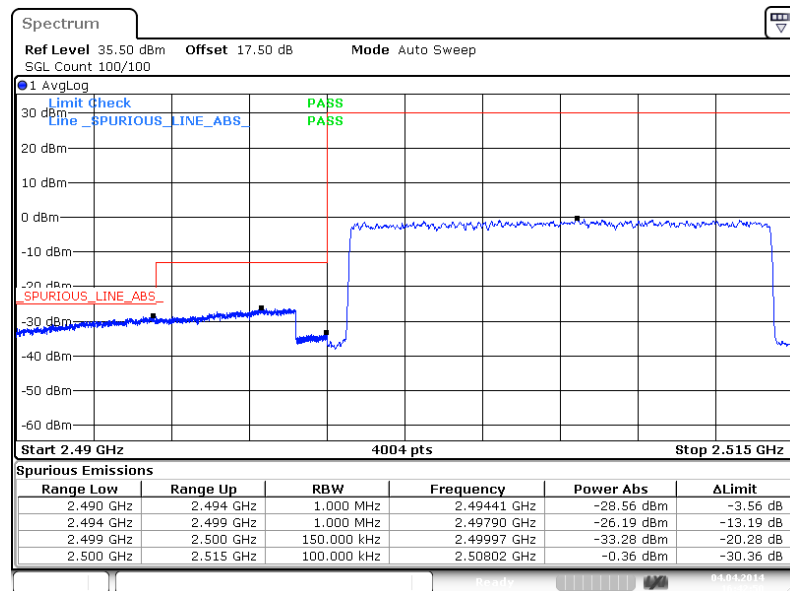



Higher Band Edge Plot for QPSK-RB Size 1, RB Offset 74

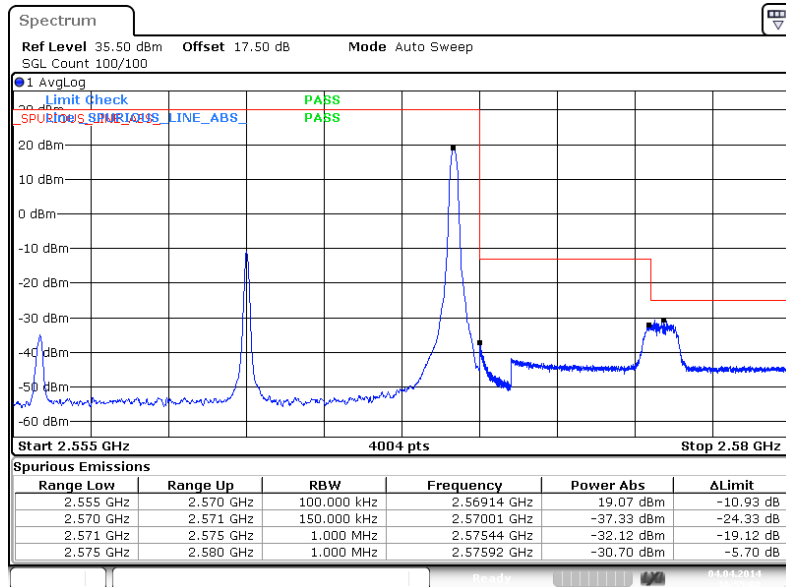

Higher Band Edge Plot for QPSK-RB Size 75, RB Offset 0

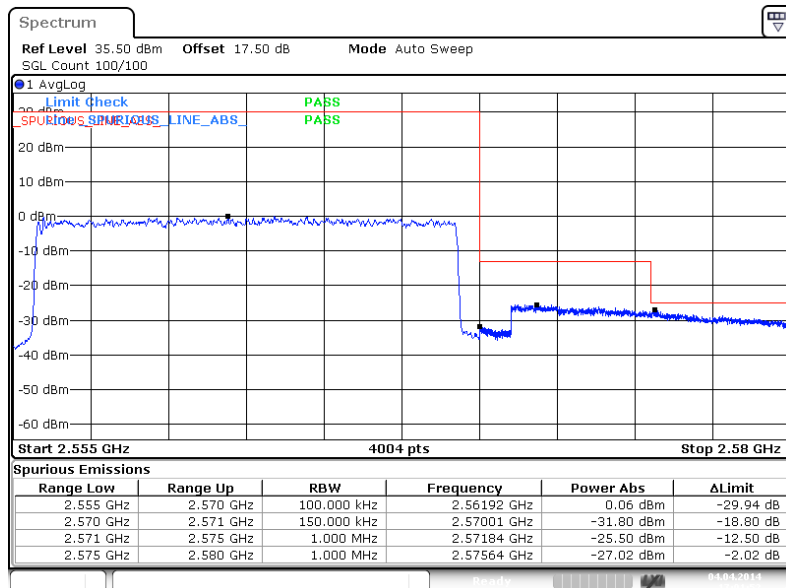



Band :	LTE Band 7	Band Width :	15MHz / 16QAM
--------	------------	--------------	---------------

Lower Band Edge Plot for 16QAM-RB Size 1, RB Offset 0

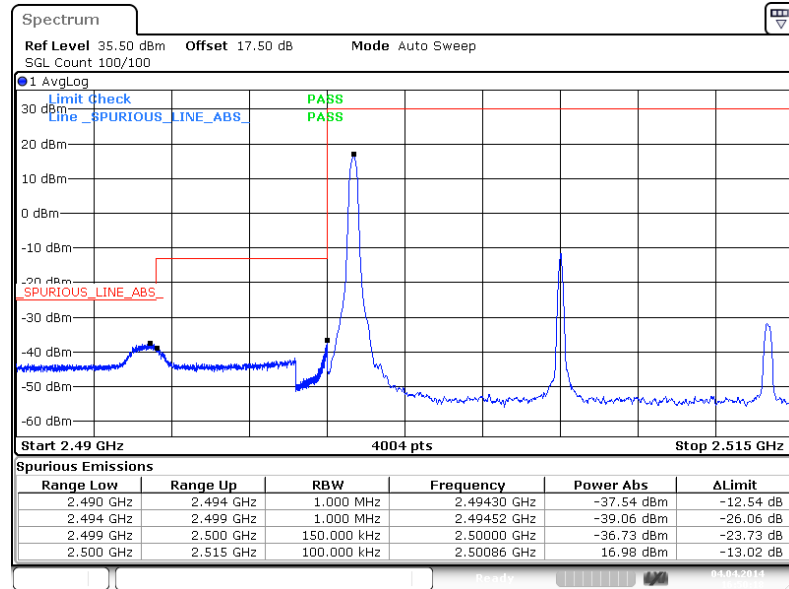

Lower Band Edge Plot for 16QAM-RB Size 75, RB Offset 0

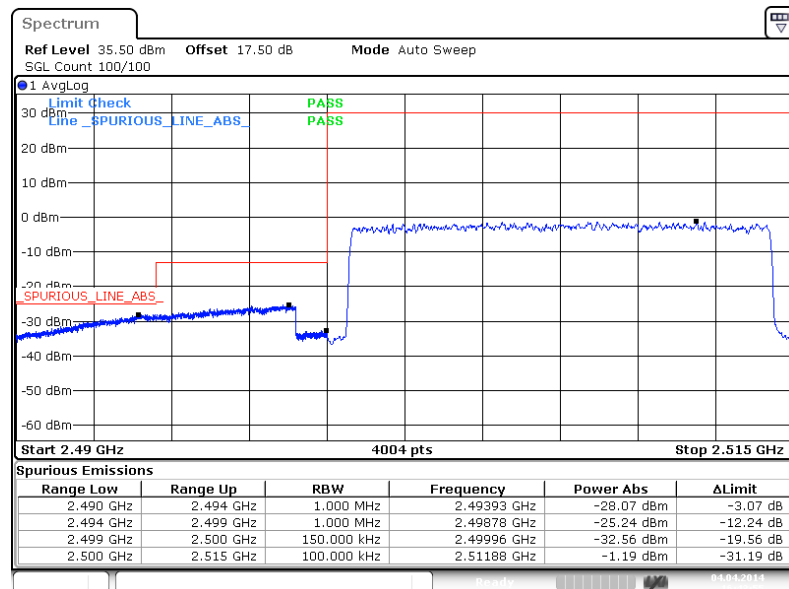

Higher Band Edge Plot for 16QAM-RB Size 1, RB Offset 74

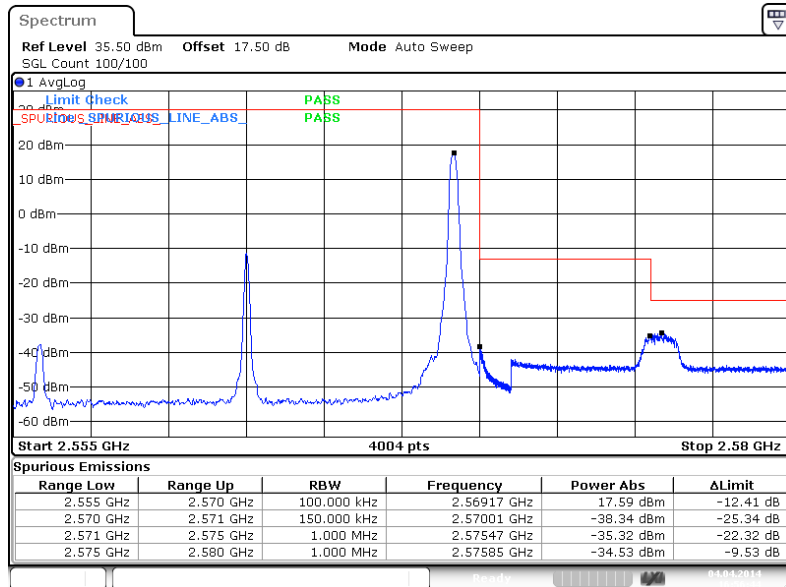

Higher Band Edge Plot for 16QAM-RB Size 75, RB Offset 0

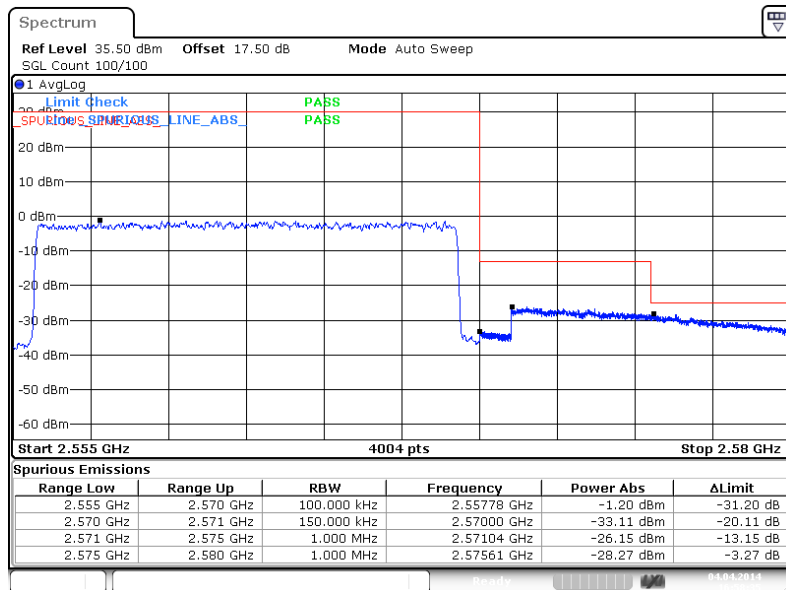



Band :	LTE Band 7	Band Width :	20MHz / QPSK
--------	------------	--------------	--------------

Lower Band Edge Plot for QPSK-RB Size 1, RB Offset 0

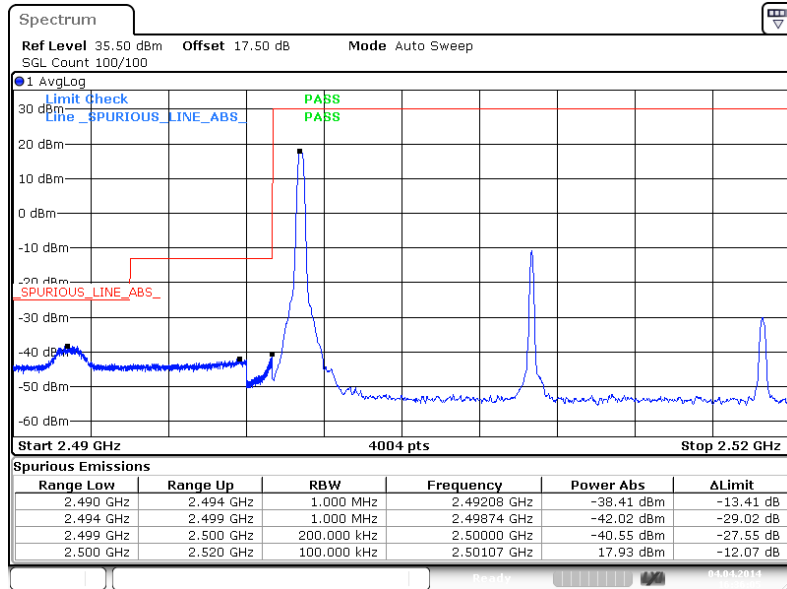

Lower Band Edge Plot for QPSK-RB Size 100, RB Offset 0

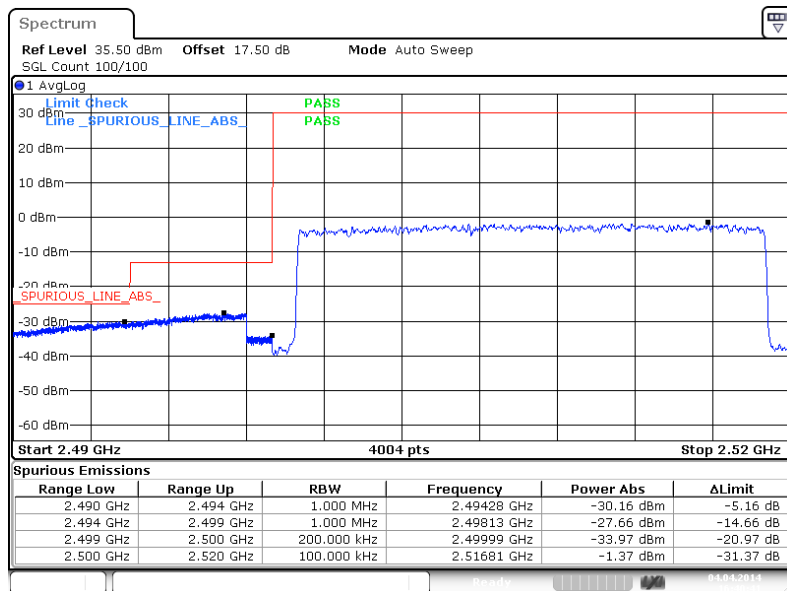



Higher Band Edge Plot for QPSK-RB Size 1, RB Offset 99

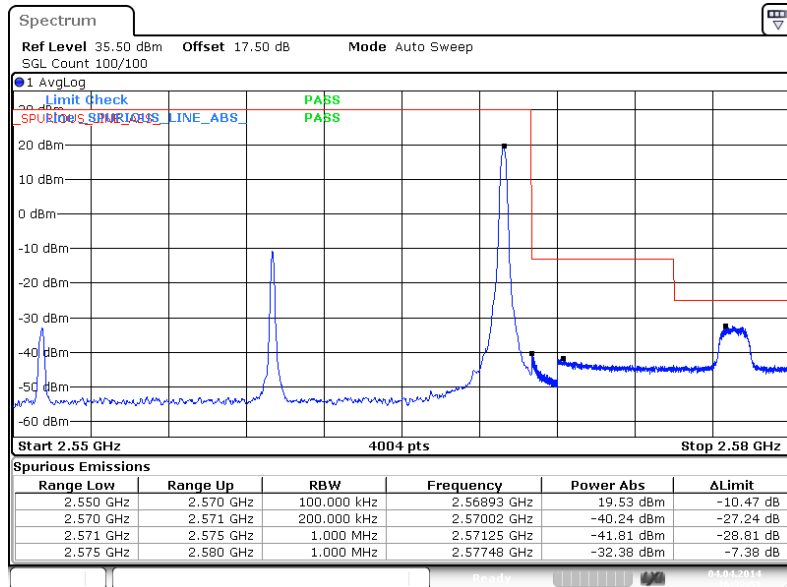

Higher Band Edge Plot for QPSK-RB Size 100, RB Offset 0

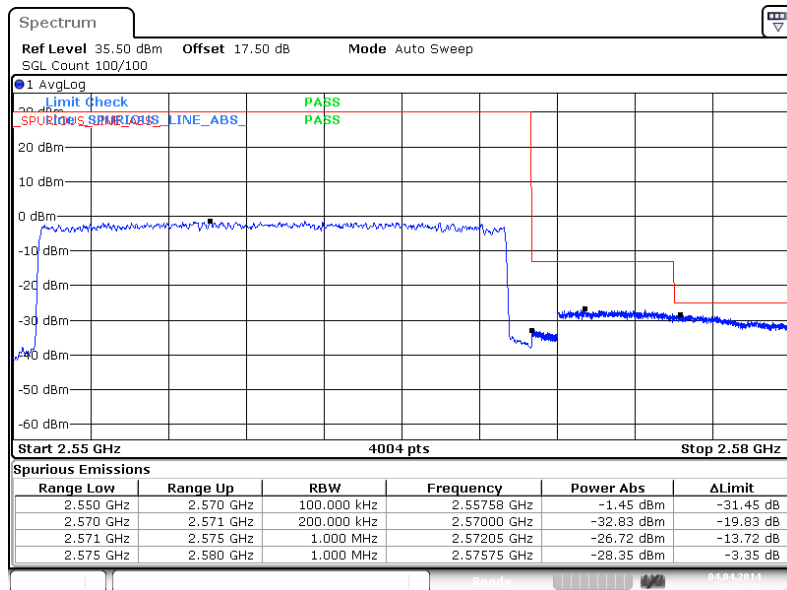



Band :	LTE Band 7	Band Width :	20MHz / 16QAM
---------------	------------	---------------------	---------------

Lower Band Edge Plot for 16QAM-RB Size 1, RB Offset 0

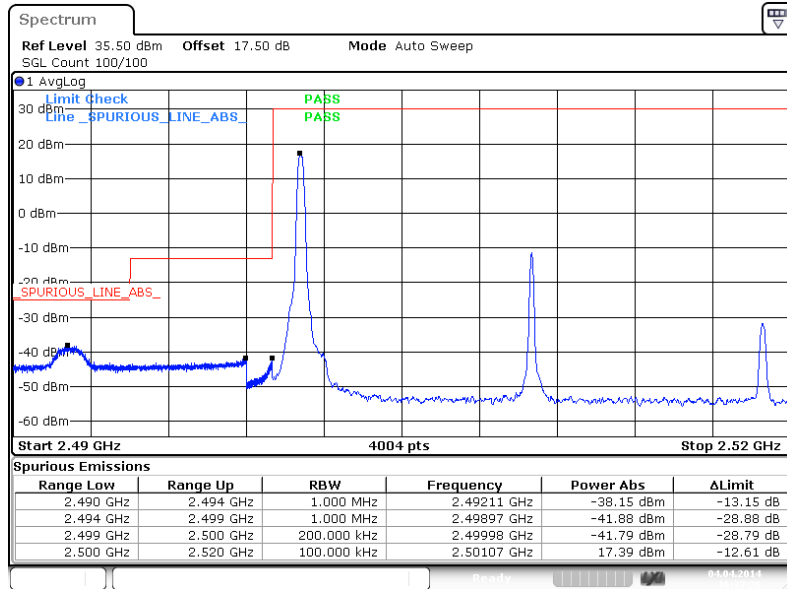

Lower Band Edge Plot for 16QAM-RB Size 100, RB Offset 0

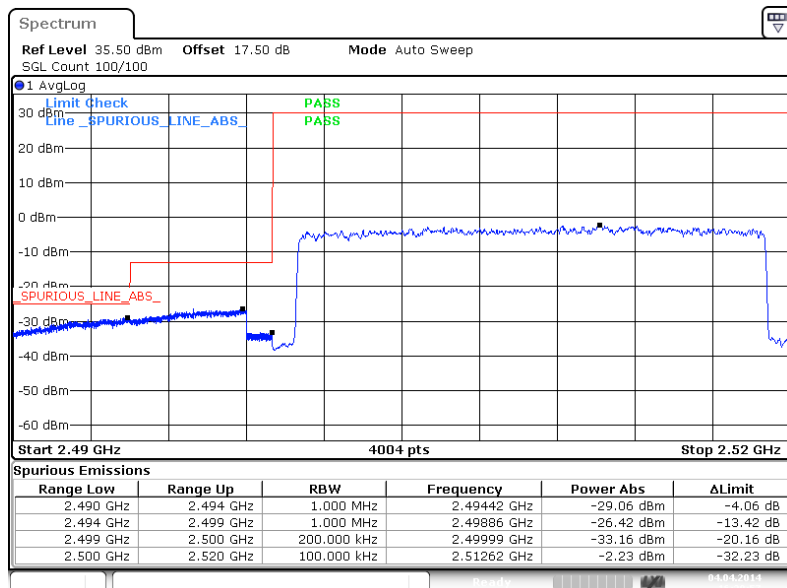



Higher Band Edge Plot for 16QAM-RB Size 1, RB Offset 99

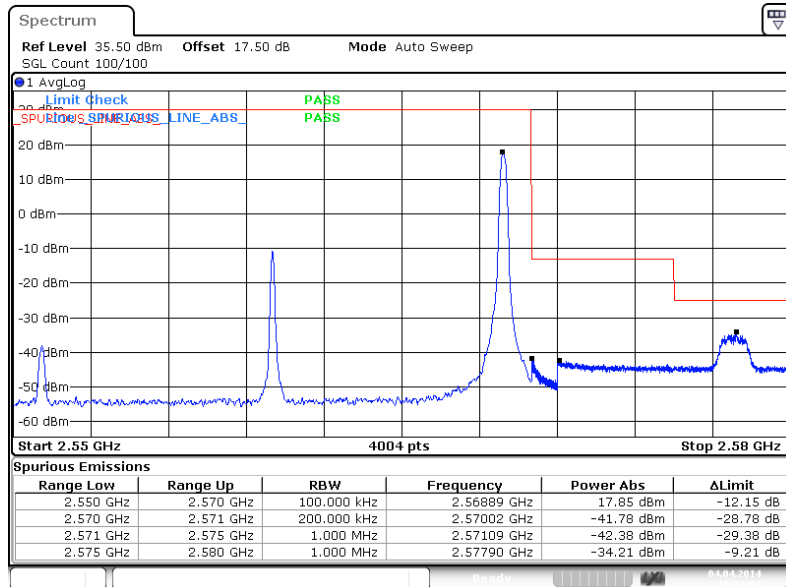

Higher Band Edge Plot for 16QAM-RB Size 100, RB Offset 0

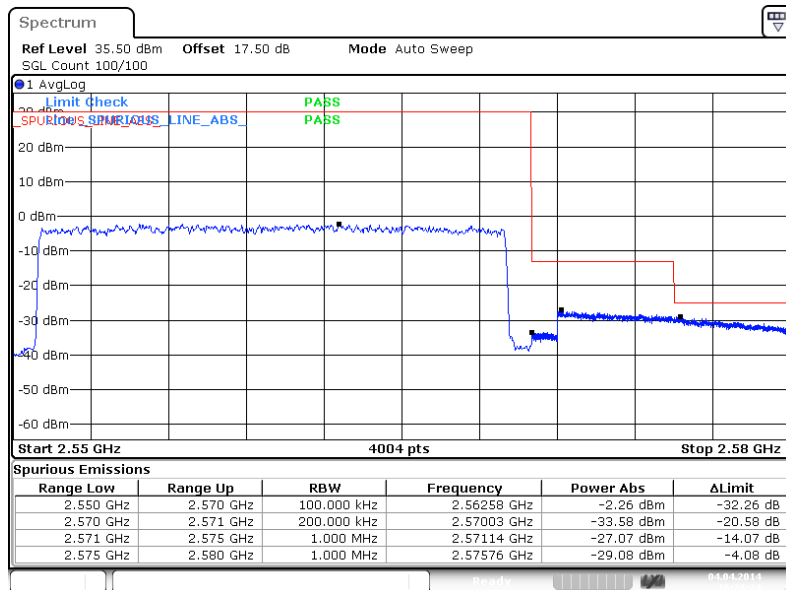



3.6 Conducted Spurious Emission Measurement

3.6.1 Description of Conducted Spurious Emission Measurement

For Band 4

The power of any emission outside of the authorized operating frequency ranges must be lower than the transmitter power (P) by a factor of at least $43 + 10 \log (P)$ dB.

For Band 7

The power of any emission outside of the authorized operating frequency ranges must be lower than the transmitter power (P) by a factor of at least $55 + 10 \log (P)$ dB.

It is measured by means of a calibrated spectrum analyzer and scanned from 30MHz up to a frequency including its 10th harmonic.

3.6.2 Measuring Instruments

The measuring equipment is listed in the section 4 of this test report.

3.6.3 Test Procedures

1. The EUT was connected to spectrum analyzer and system simulator via a power divider.
2. The RF output of EUT was connected to the spectrum analyzer by RF cable and attenuator. The path loss was compensated to the results for each measurement.
3. The middle channel for the highest RF power within the transmitting frequency was measured.
4. The conducted spurious emission for the whole frequency range was taken.
5. Make the measurement with the spectrum analyzer's RBW = 1MHz, VBW = 3MHz, taking the record of maximum spurious emission.
6. The RF fundamental frequency should be excluded against the limit line in the operating frequency band.
7. For LTE Band 4:

The limit line is derived from $43 + 10\log(P)$ dB below the transmitter power P(Watts)
= P(W)- [43 + 10log(P)] (dB)
= [30 + 10log(P)] (dBm) - [43 + 10log(P)] (dB)
= -13dBm.

8. For LTE Band 7:

The limit line is derived from $55 + 10\log(P)$ dB below the transmitter power P(Watts)
= P(W)- [55 + 10log(P)] (dB)
= [30 + 10log(P)] (dBm) - [55 + 10log(P)] (dB)
= -25dBm.

3.6.4 Test Setup

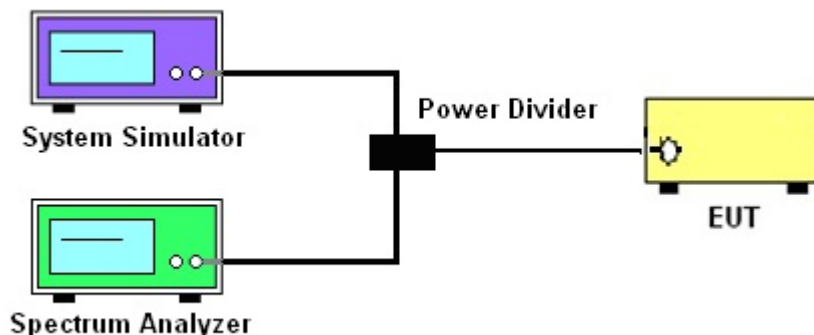



3.6.5 Test Result (Plots) of Conducted Spurious Emission

Band :	LTE Band 4	Channel :	CH19957 (Low)
Band Width :	1.4MHz		

QPSK (RB Size 3, RB Offset 0)

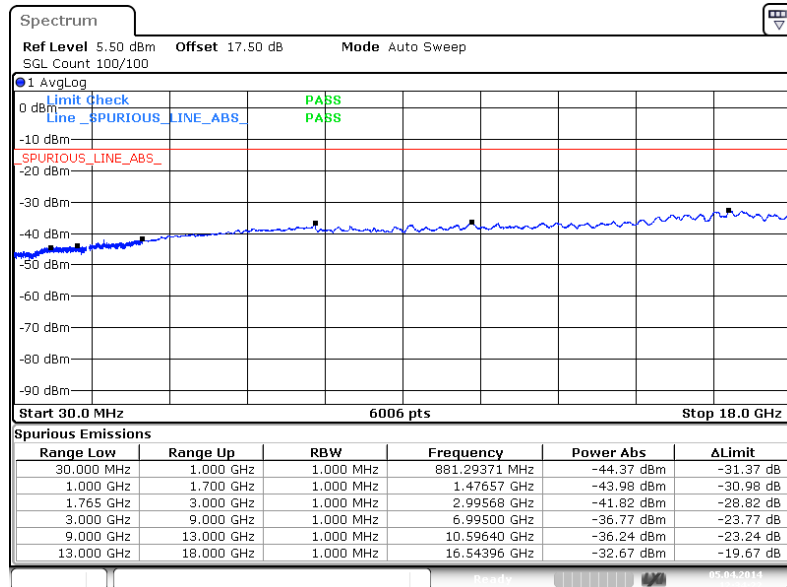

16QAM (RB Size 1, RB Offset 5)

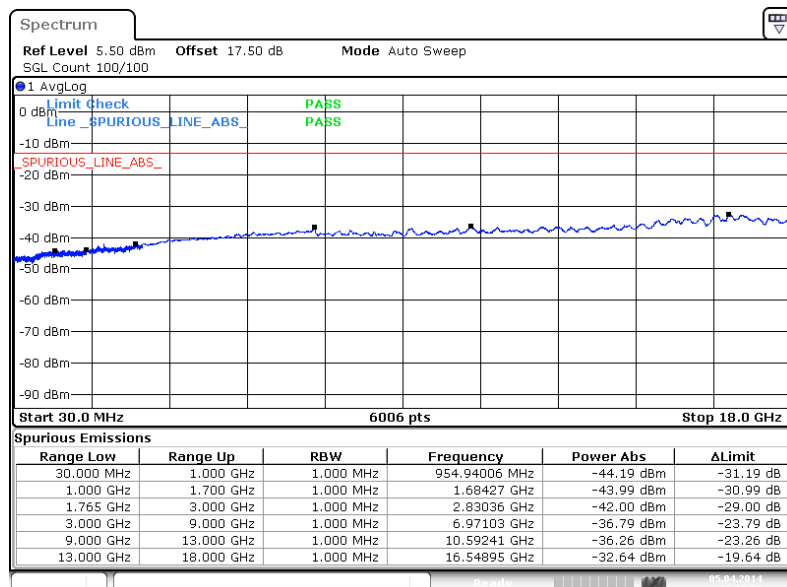



Band :	LTE Band 4	Channel :	CH20175 (Middle)
Band Width :	1.4MHz		

QPSK (RB Size 3, RB Offset 1)

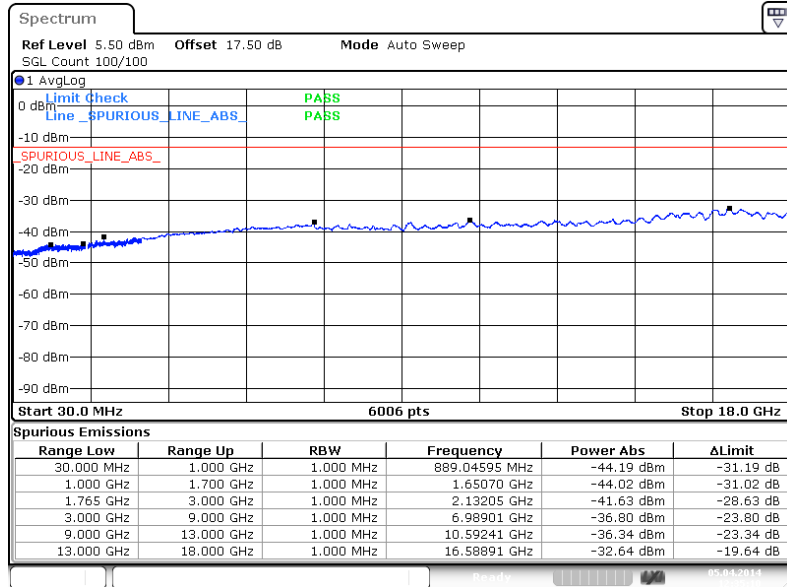

16QAM (RB Size 3, RB Offset 1)

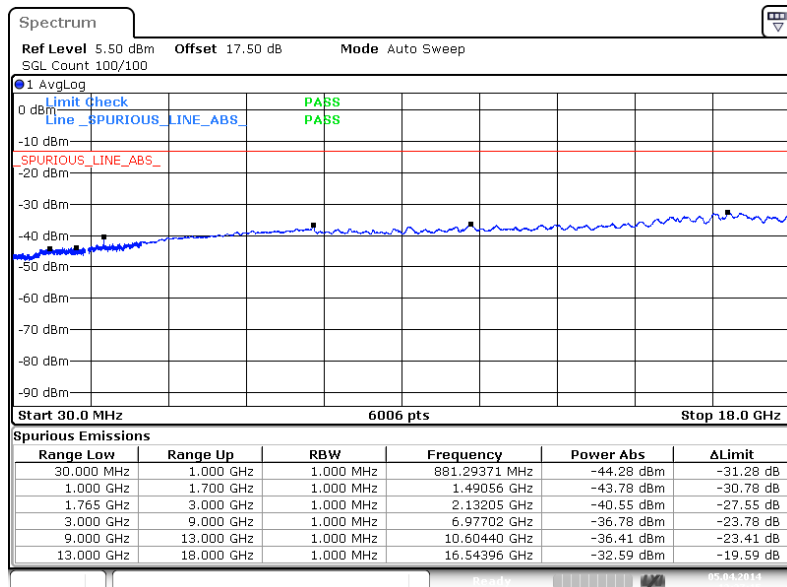



Band :	LTE Band 4	Channel :	CH20393 (High)
Band Width :	1.4MHz		

QPSK (RB Size 1, RB Offset 0)

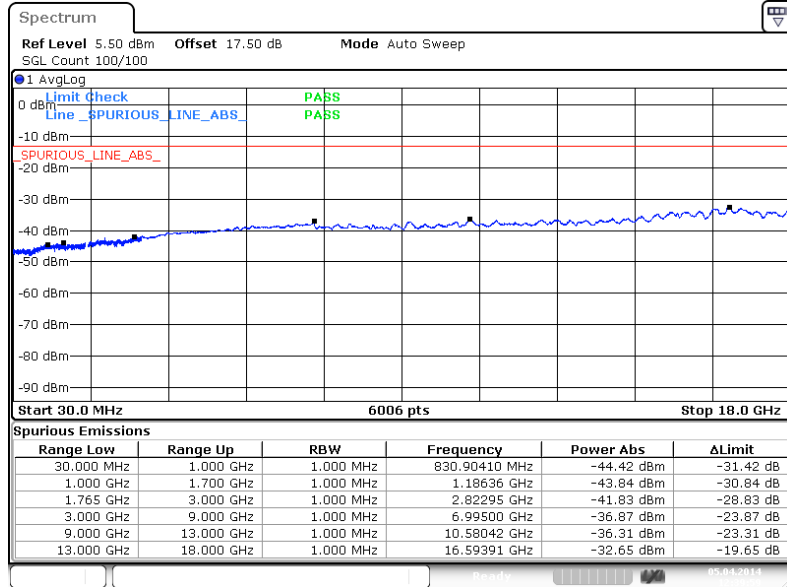

16QAM (RB Size 1, RB Offset 5)

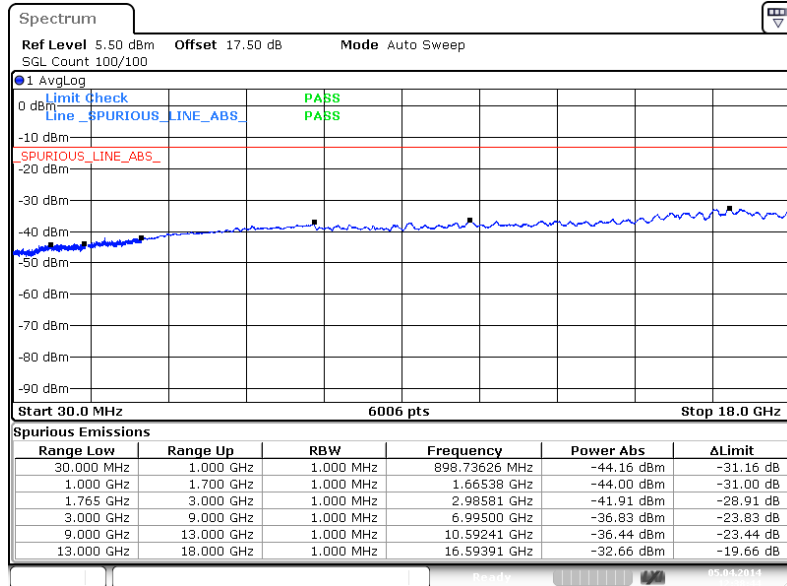



Band :	LTE Band 4	Channel :	CH19965 (Low)
Band Width :	3MHz		

QPSK (RB Size 1, RB Offset 7)

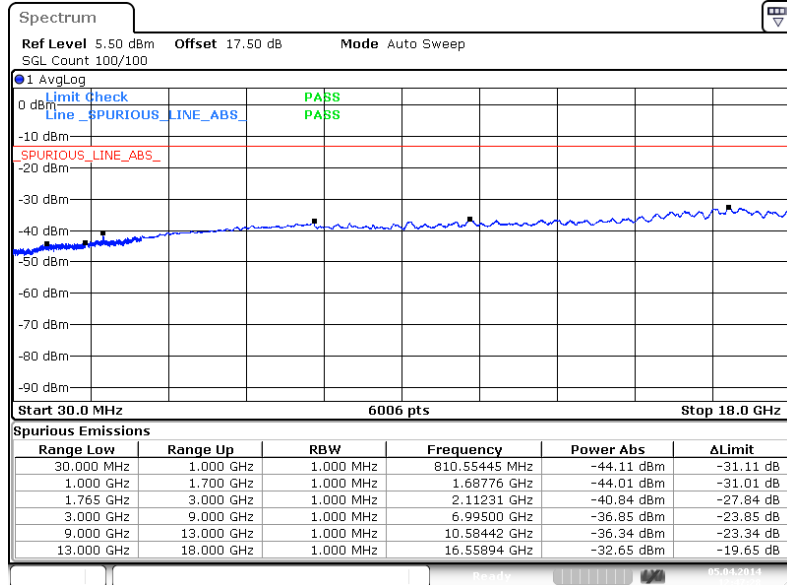

16QAM (RB Size 1, RB Offset 0)

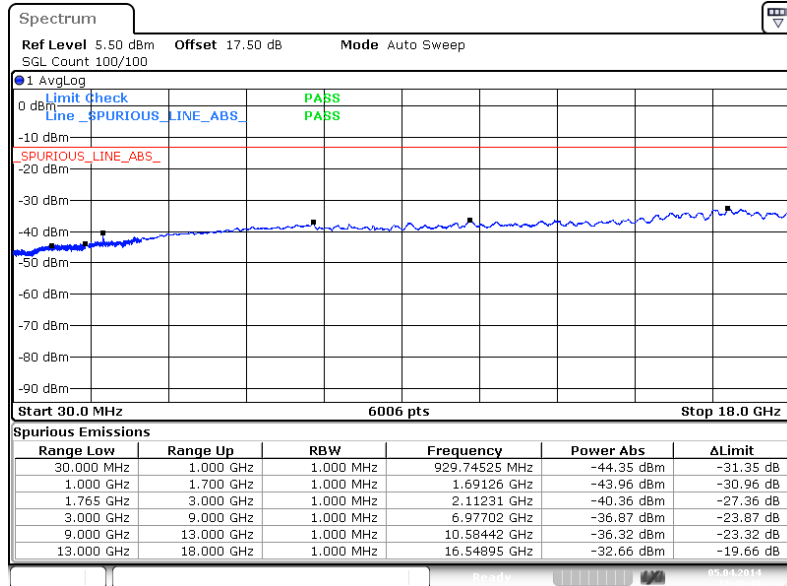



Band :	LTE Band 4	Channel :	CH20175 (Middle)
Band Width :	3MHz		

QPSK (RB Size 1, RB Offset 0)

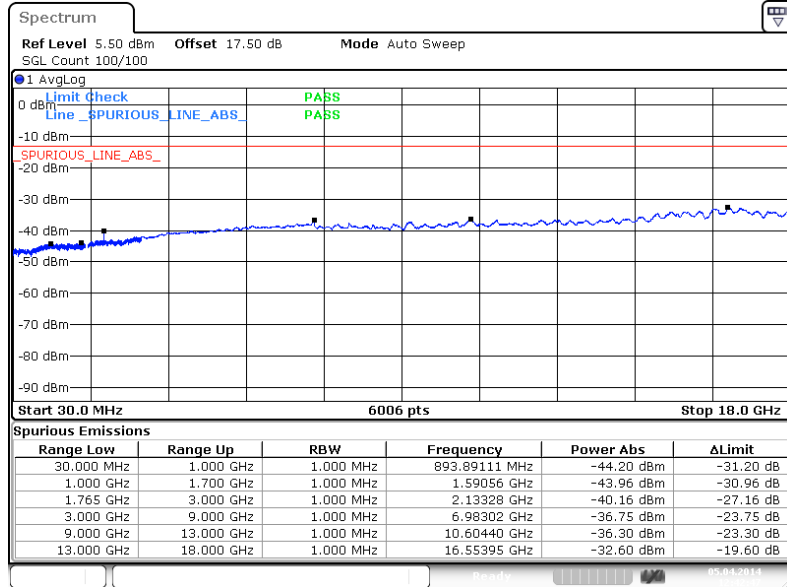

16QAM (RB Size 1, RB Offset 7)

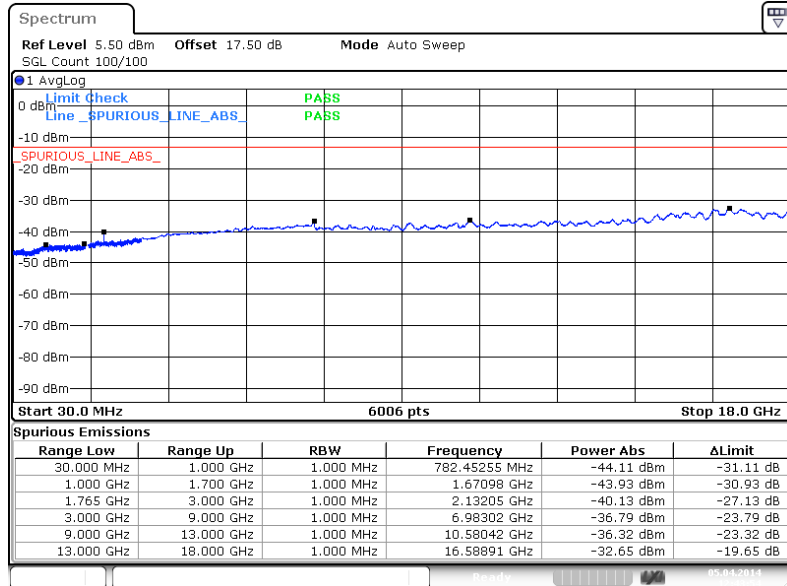



Band :	LTE Band 4	Channel :	CH20385 (High)
Band Width :	3MHz		

QPSK (RB Size 1, RB Offset 0)

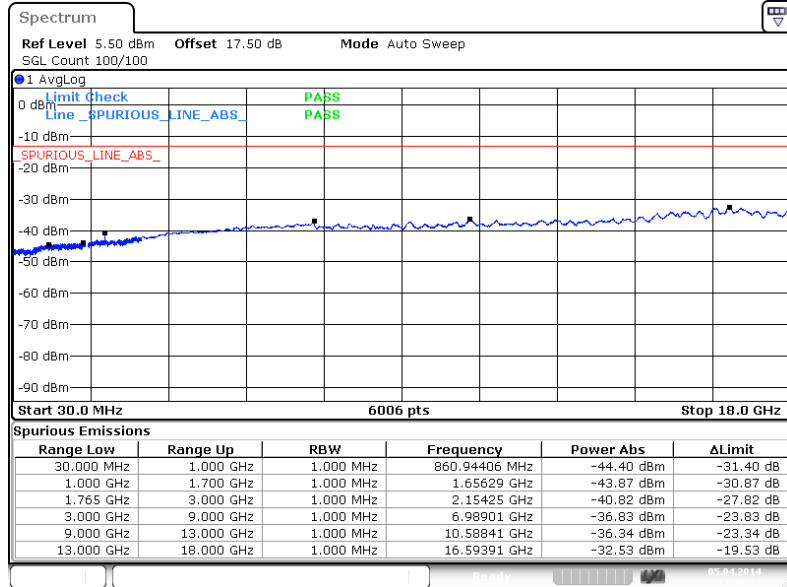

16QAM (RB Size 1, RB Offset 7)

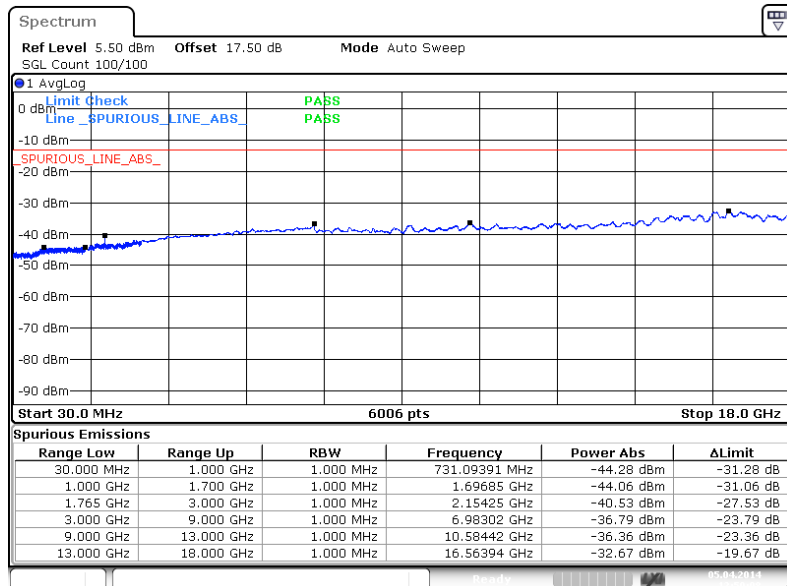



Band :	LTE Band 4	Channel :	CH19975 (Low)
Band Width :	5MHz		

QPSK (RB Size 1, RB Offset 24)

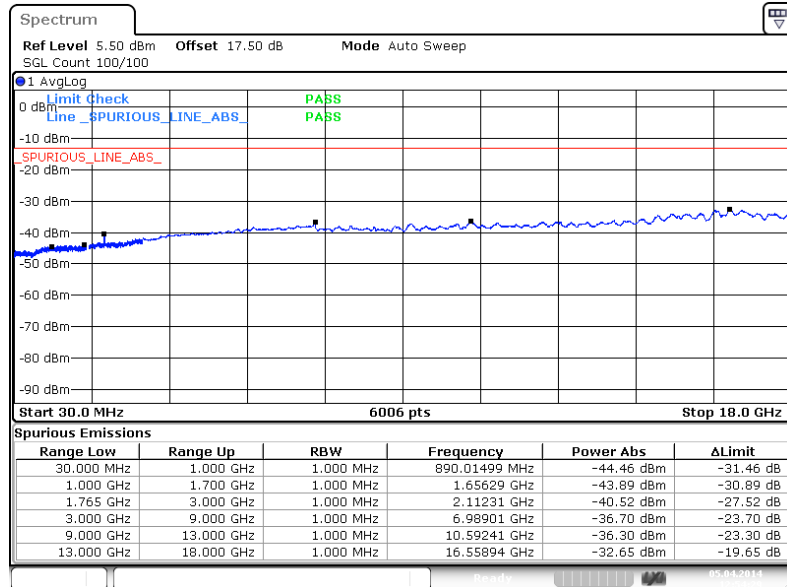

16QAM (RB Size 1, RB Offset 0)

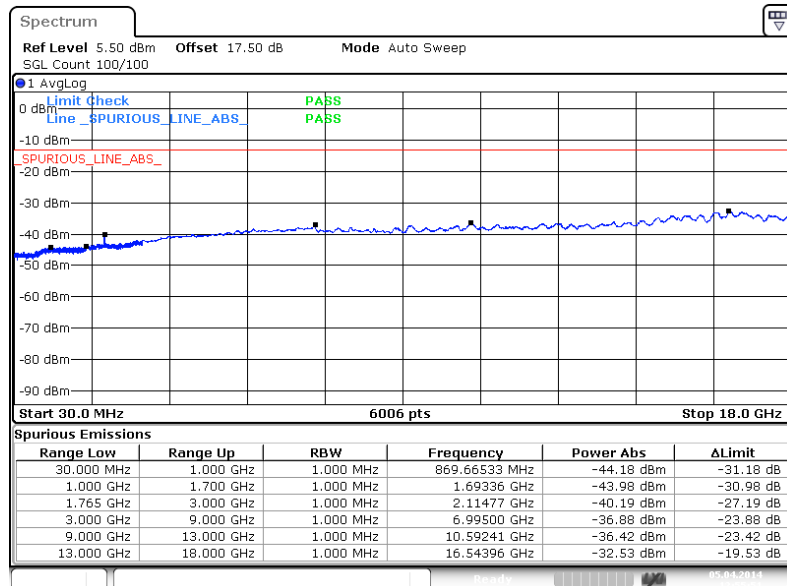



Band :	LTE Band 4	Channel :	CH20175 (Middle)
Band Width :	5MHz		

QPSK (RB Size 1, RB Offset 0)

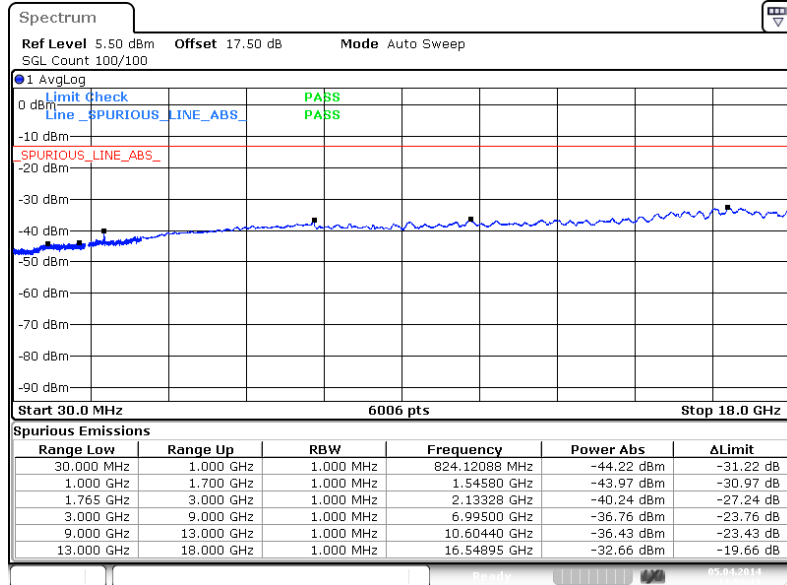

16QAM (RB Size 1, RB Offset 24)

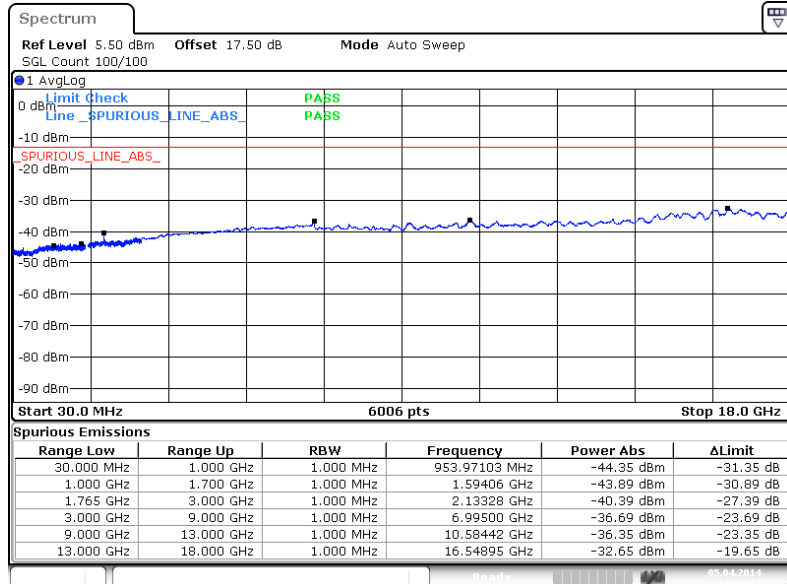



Band :	LTE Band 4	Channel :	CH20375 (High)
Band Width :	5MHz		

QPSK (RB Size 1, RB Offset 24)

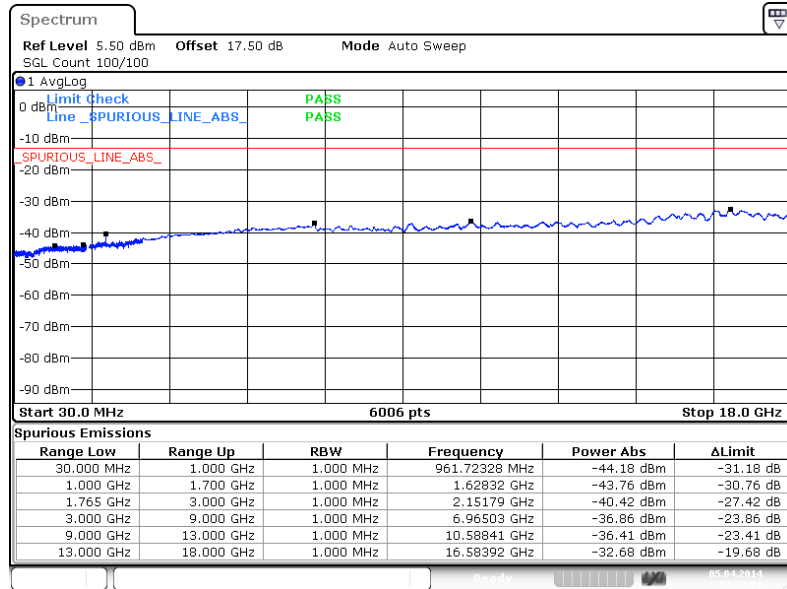

16QAM (RB Size 1, RB Offset 0)

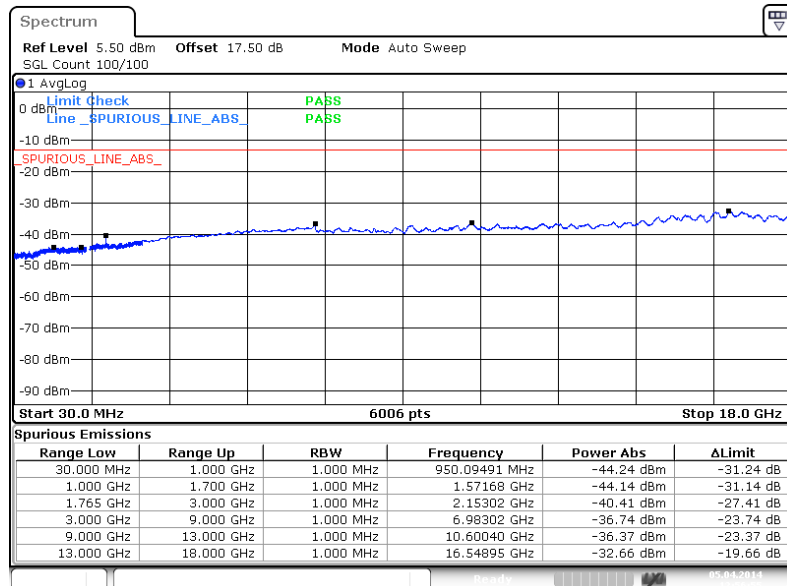



Band :	LTE Band 4	Channel :	CH20000 (Low)
Band Width :	10MHz		

QPSK (RB Size 1, RB Offset 0)

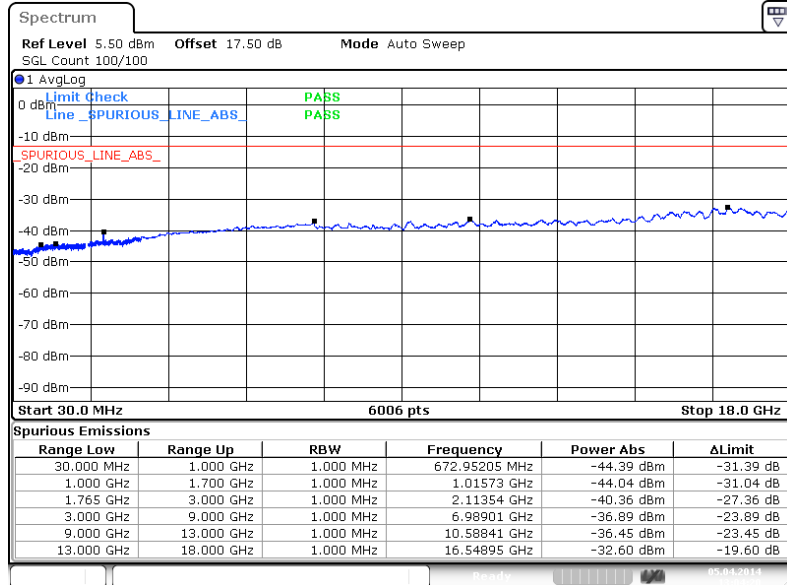

16QAM (RB Size 1, RB Offset 24)

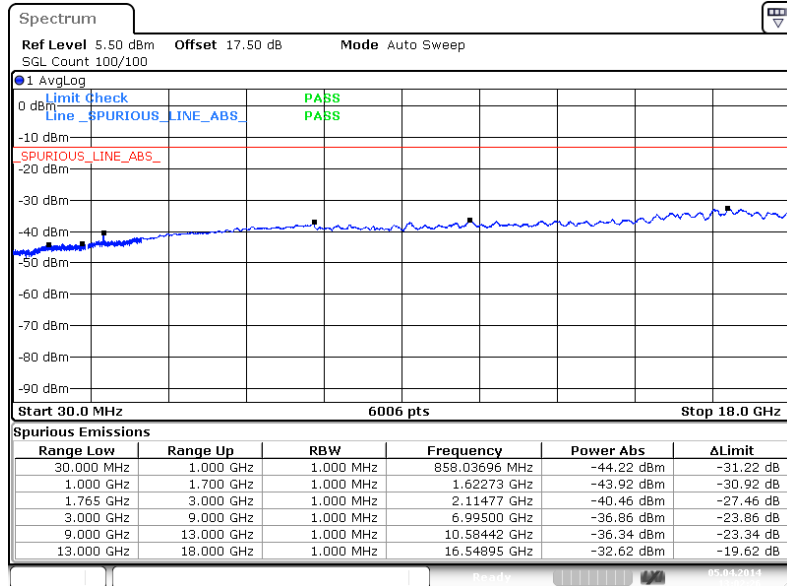



Band :	LTE Band 4	Channel :	CH20175 (Middle)
Band Width :	10MHz		

QPSK (RB Size 1, RB Offset 0)

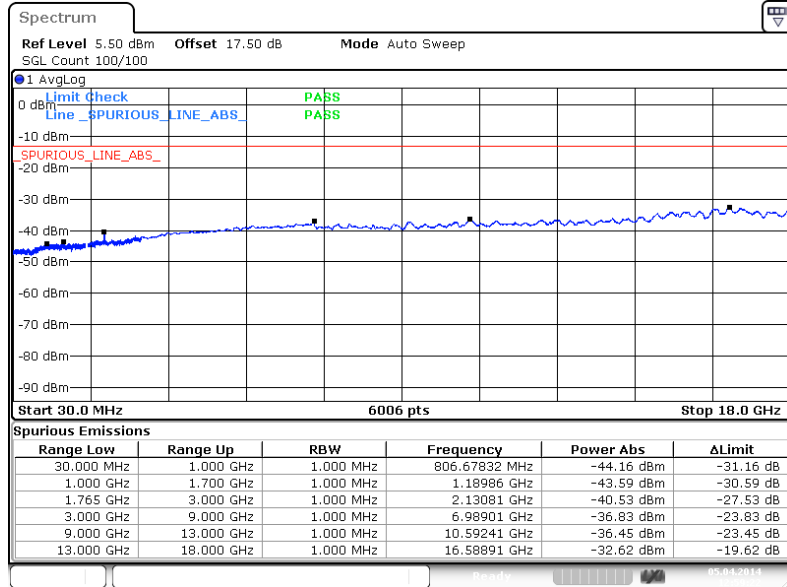

16QAM (RB Size 1, RB Offset 49)

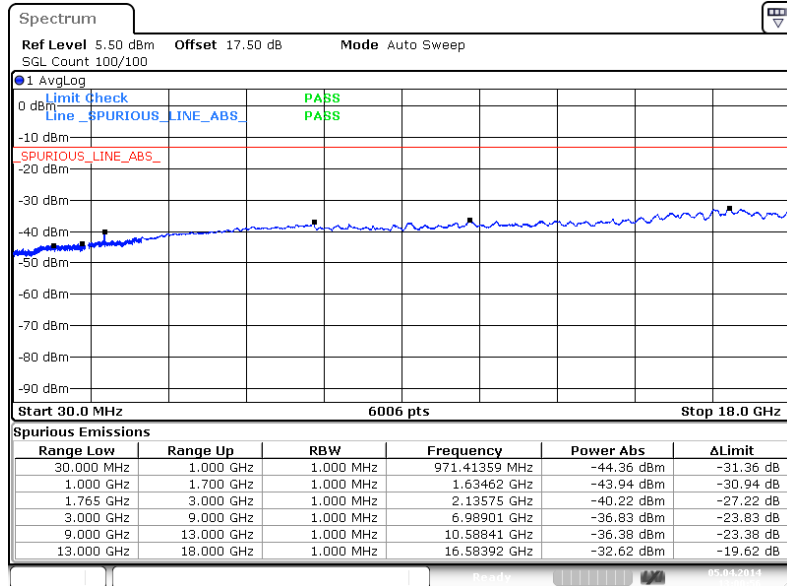



Band :	LTE Band 4	Channel :	CH20350 (High)
Band Width :	10MHz		

QPSK (RB Size 1, RB Offset 24)

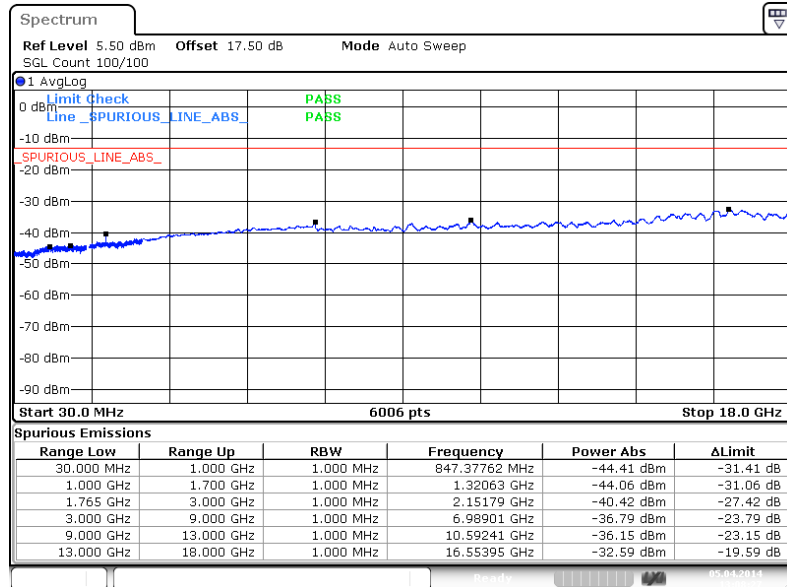

16QAM (RB Size 1, RB Offset 24)

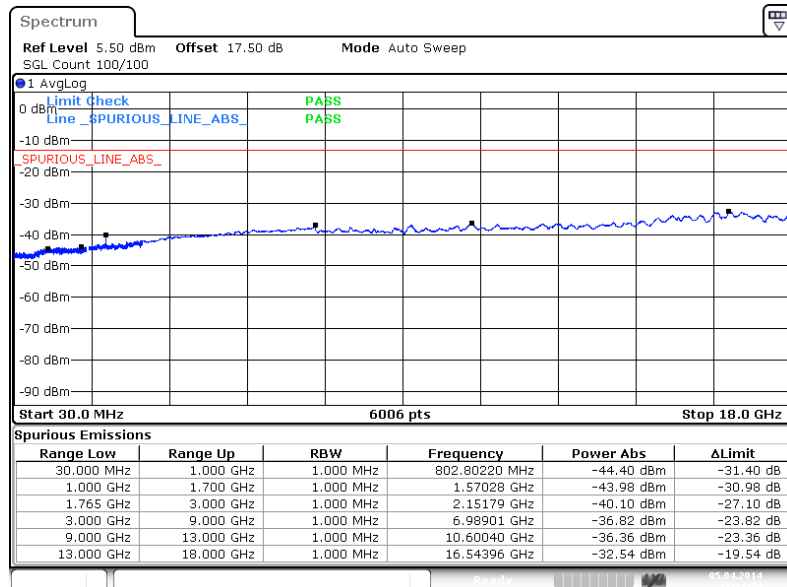



Band :	LTE Band 4	Channel :	CH20025 (Low)
Band Width :	15MHz		

QPSK (RB Size 1, RB Offset 0)

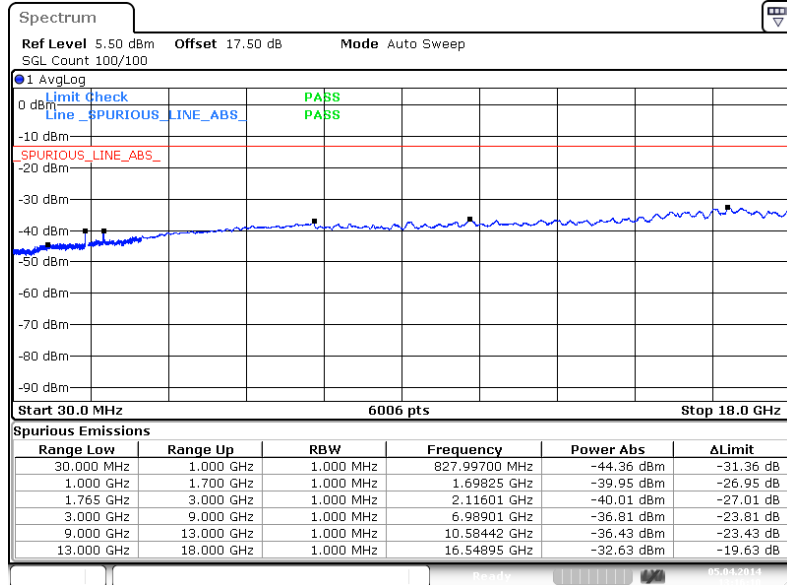

16QAM (RB Size 1, RB Offset 37)

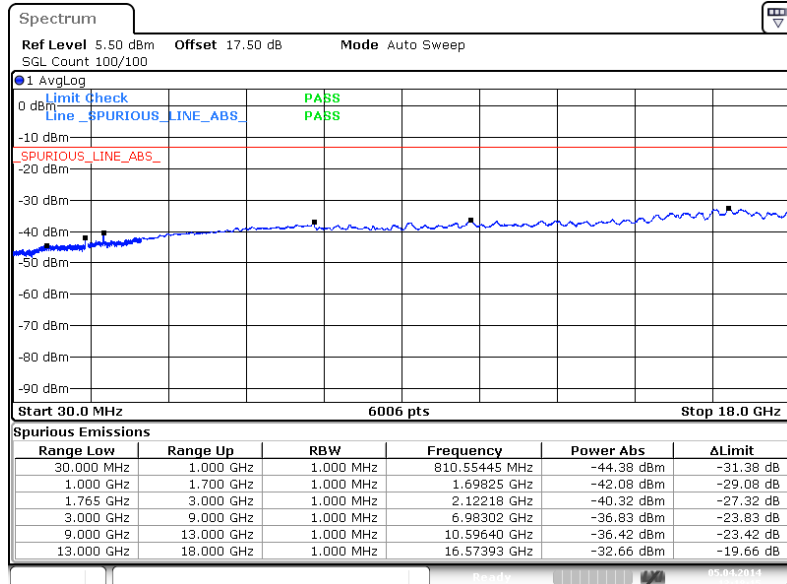



Band :	LTE Band 4	Channel :	CH20175 (Middle)
Band Width :	15MHz		

QPSK (RB Size 1, RB Offset 74)

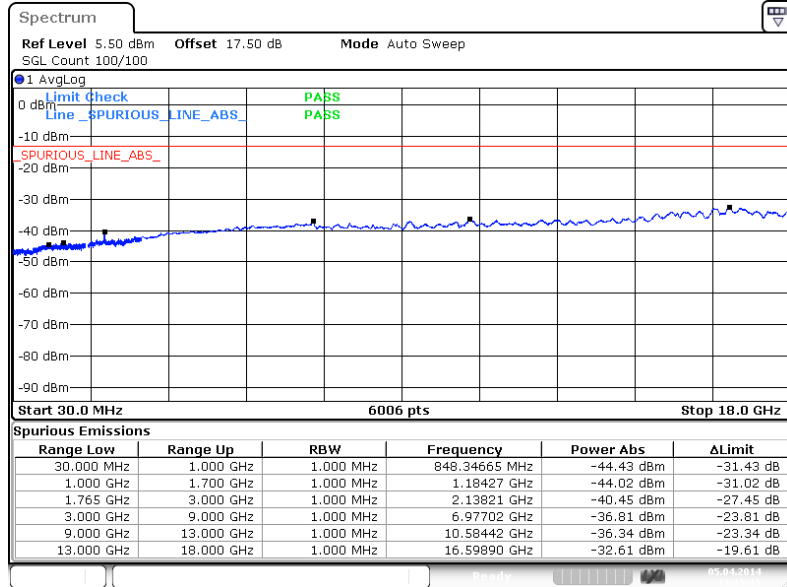

16QAM (RB Size 1, RB Offset 0)

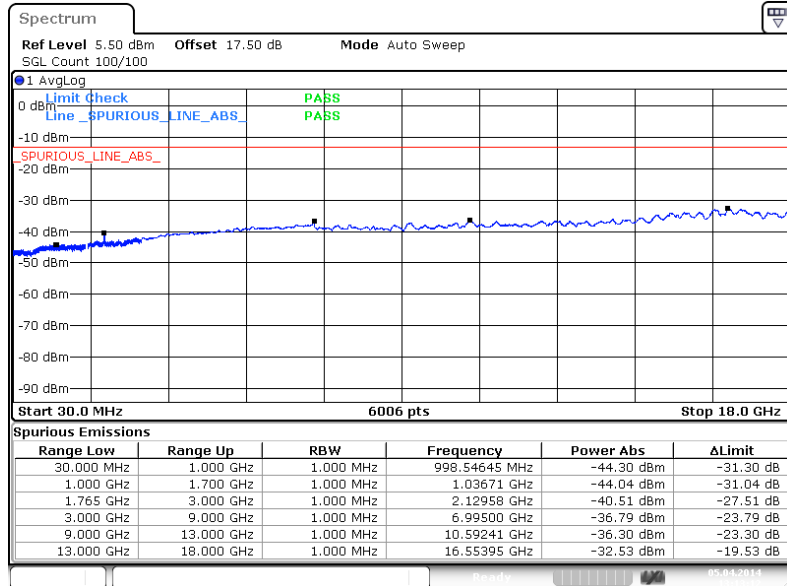



Band :	LTE Band 4	Channel :	CH20325 (High)
Band Width :	15MHz		

QPSK (RB Size 1, RB Offset 0)

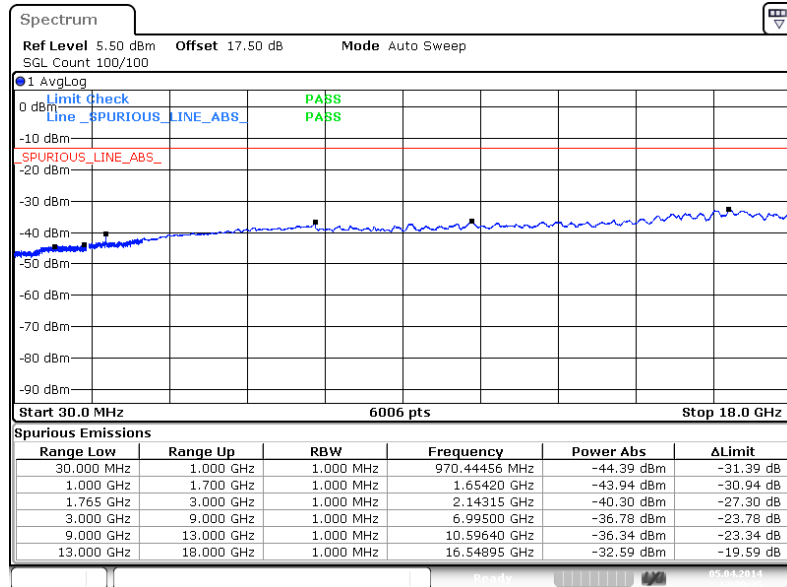

16QAM (RB Size 1, RB Offset 37)

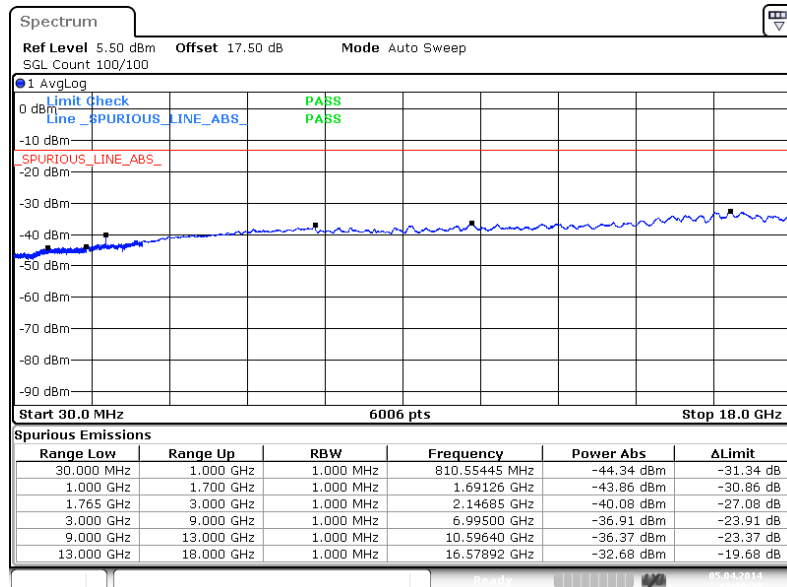



Band :	LTE Band 4	Channel :	CH20050 (Low)
Band Width :	20MHz		

QPSK (RB Size 1, RB Offset 0)

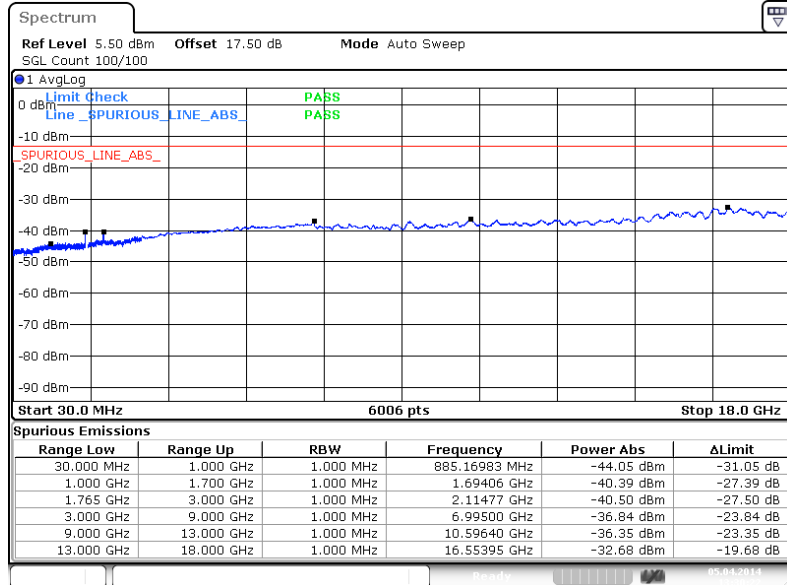

16QAM (RB Size 1, RB Offset 0)

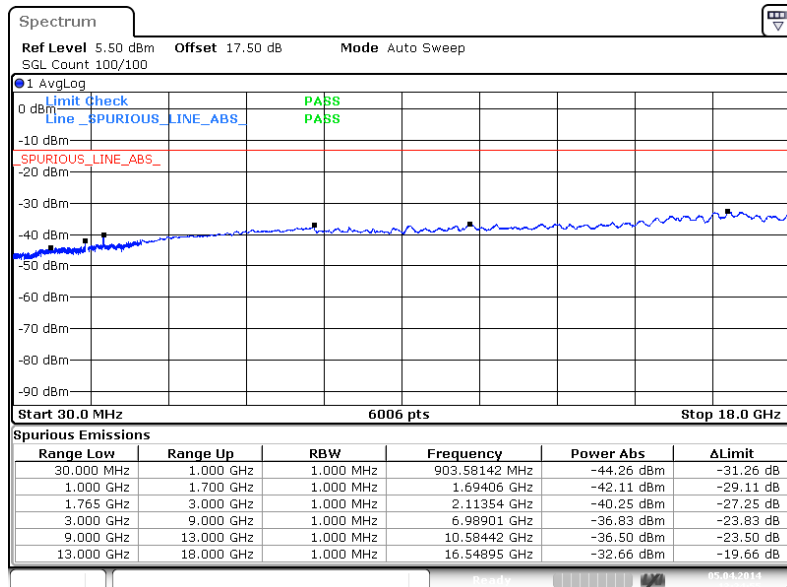



Band :	LTE Band 4	Channel :	CH20175 (Middle)
Band Width :	20MHz		

QPSK (RB Size 1, RB Offset 49)

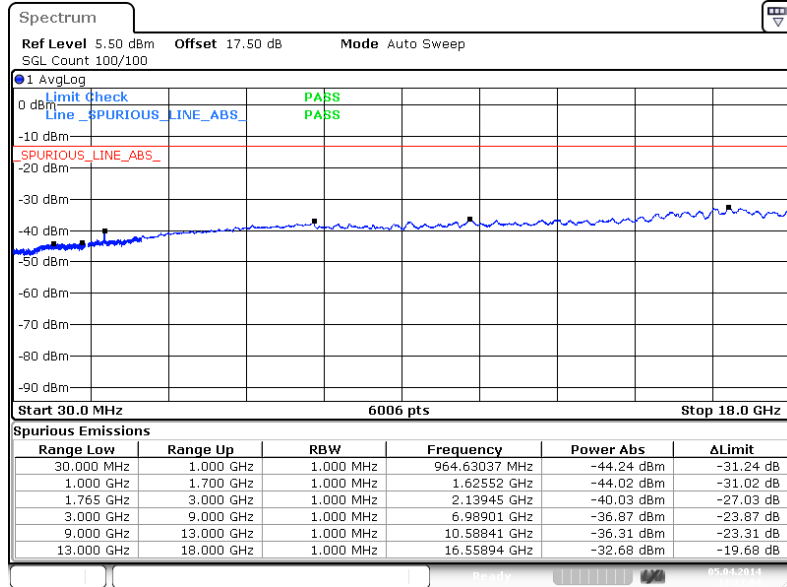

16QAM (RB Size 1, RB Offset 49)

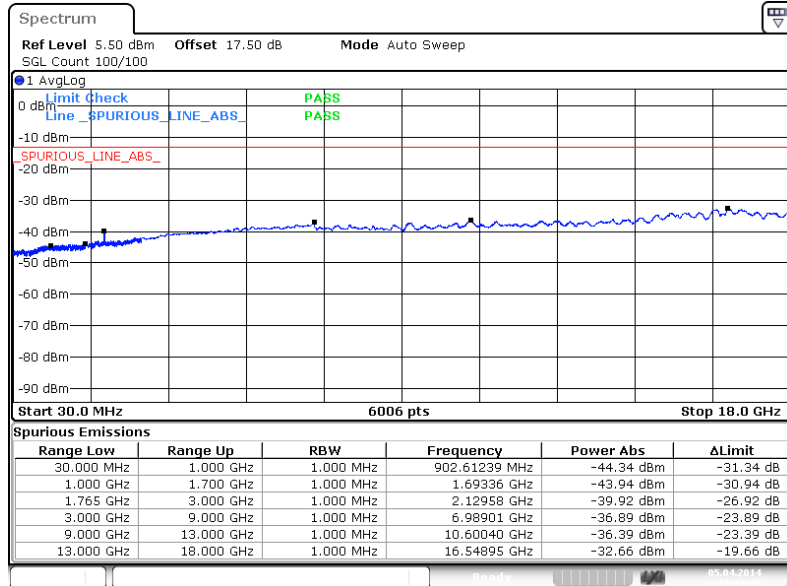



Band :	LTE Band 4	Channel :	CH20300 (High)
Band Width :	20MHz		

QPSK (RB Size 1, RB Offset 0)

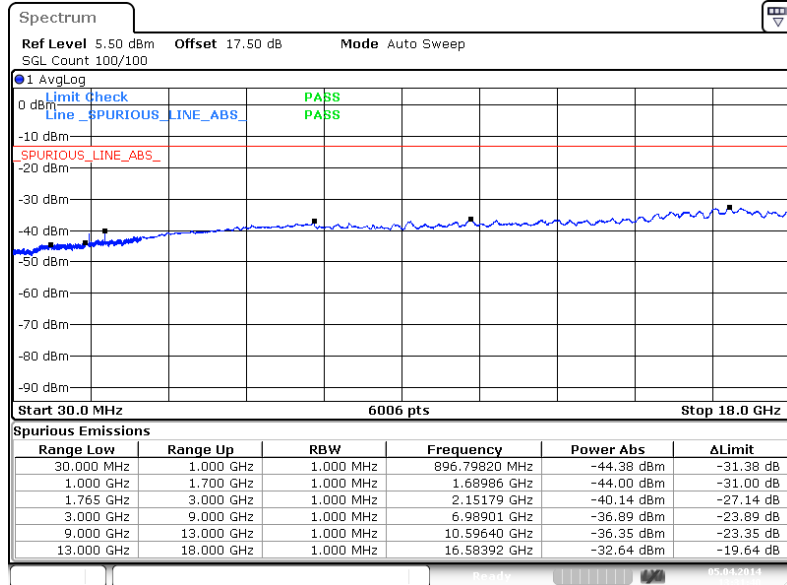

16QAM (RB Size 1, RB Offset 49)

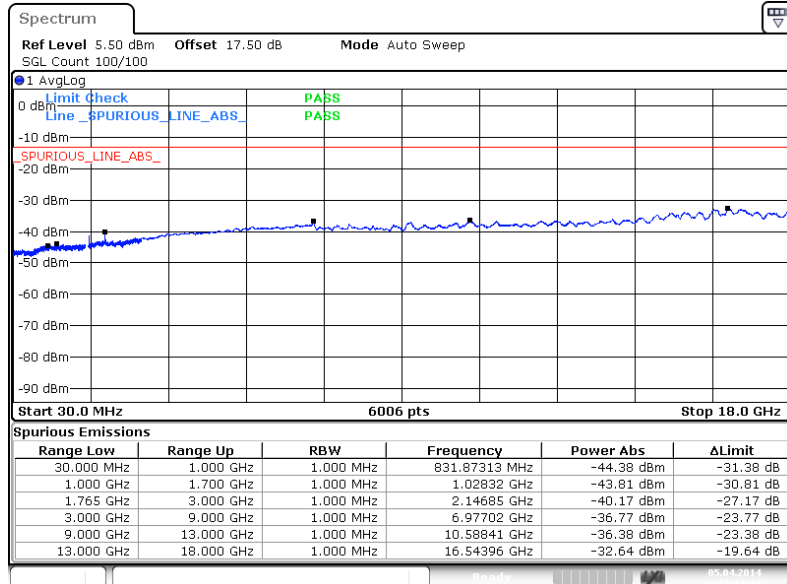



Band :	LTE Band 7	Channel :	CH20775 (Low)
Band Width :	5MHz		

QPSK (RB Size 1, RB Offset 0)

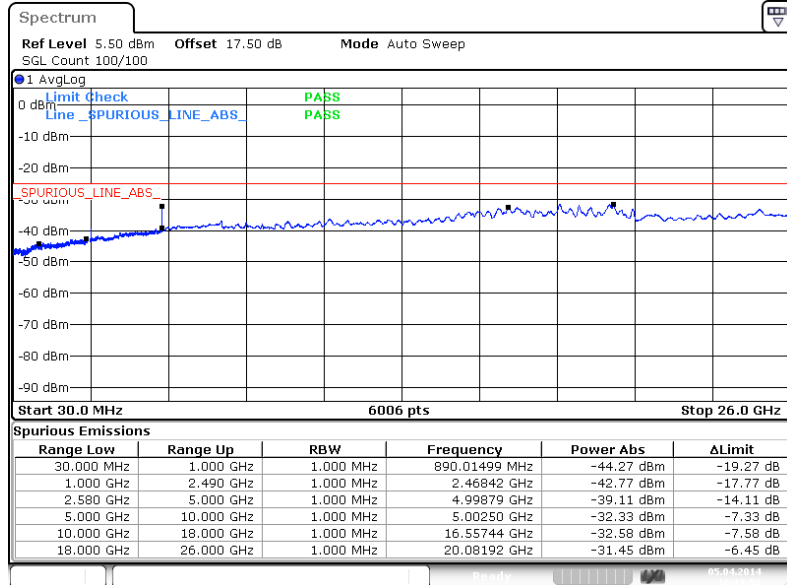

16QAM (RB Size 1, RB Offset 0)

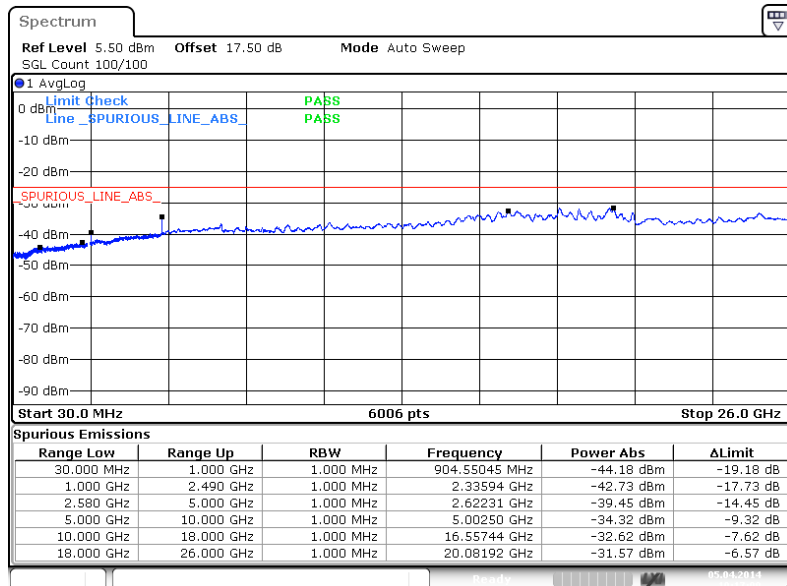



Band :	LTE Band 7	Channel :	CH21100 (Middle)
Band Width :	5MHz		

QPSK (RB Size 1, RB Offset 12)

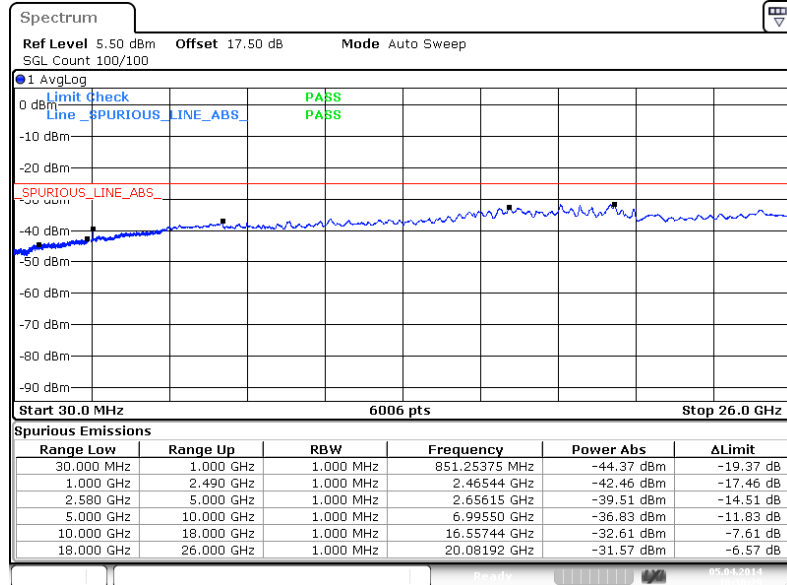

16QAM (RB Size 1, RB Offset 0)

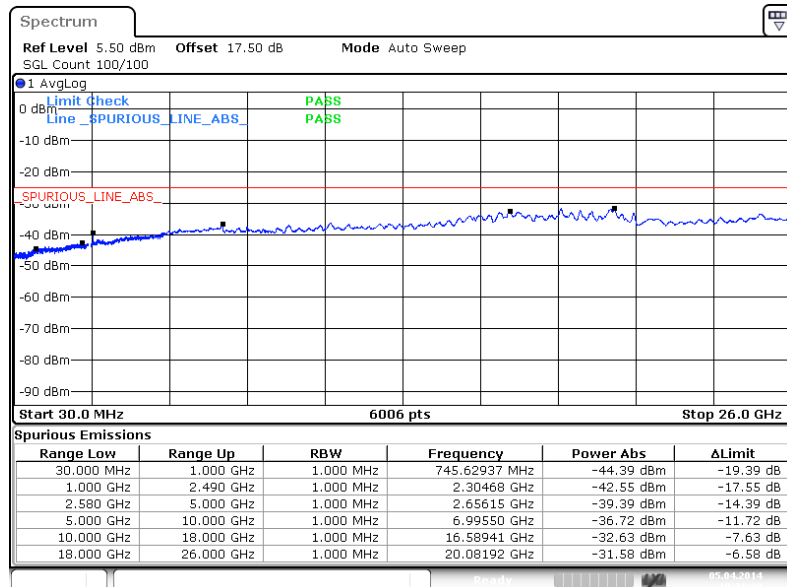



Band :	LTE Band 7	Channel :	CH21425 (High)
Band Width :	5MHz		

QPSK (RB Size 1, RB Offset 24)

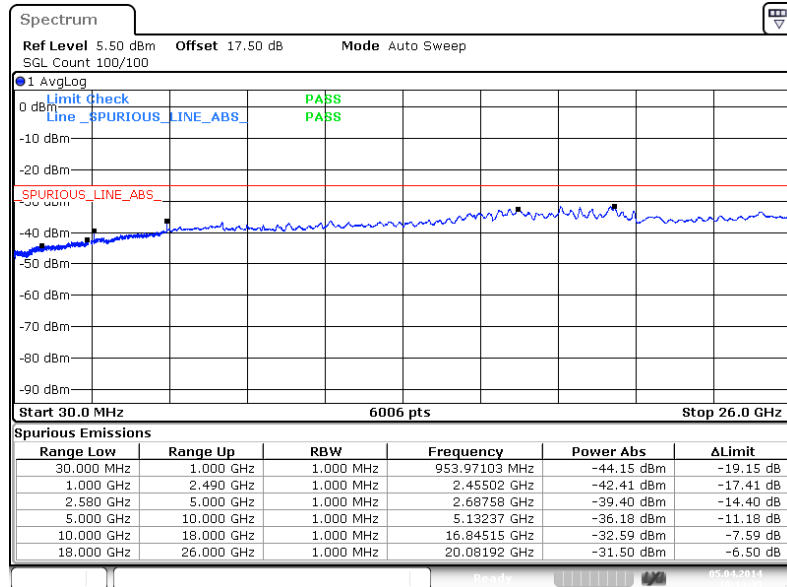

16QAM (RB Size 1, RB Offset 0)

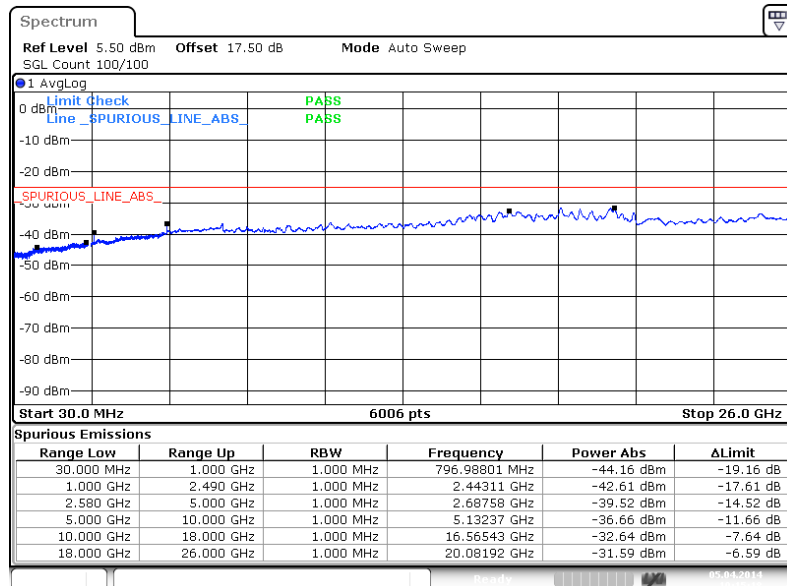



Band :	LTE Band 7	Channel :	CH20800 (Low)
Band Width :	10MHz		

QPSK (RB Size 1, RB Offset 0)

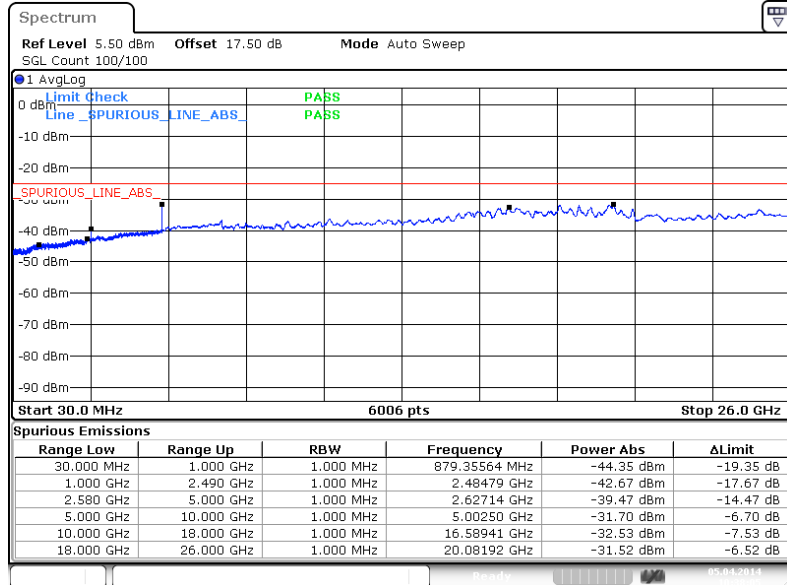

16QAM (RB Size 1, RB Offset 24)

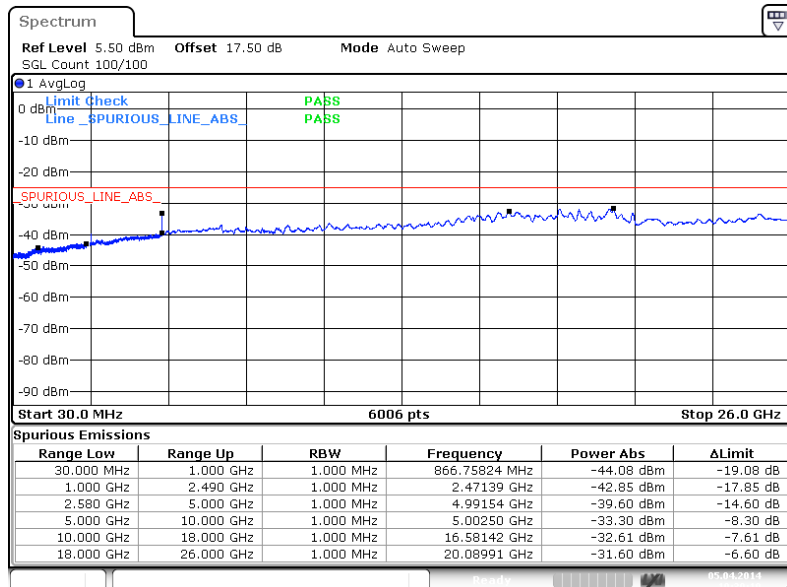



Band :	LTE Band 7	Channel :	CH21100 (Middle)
Band Width :	10MHz		

QPSK (RB Size 1, RB Offset 0)

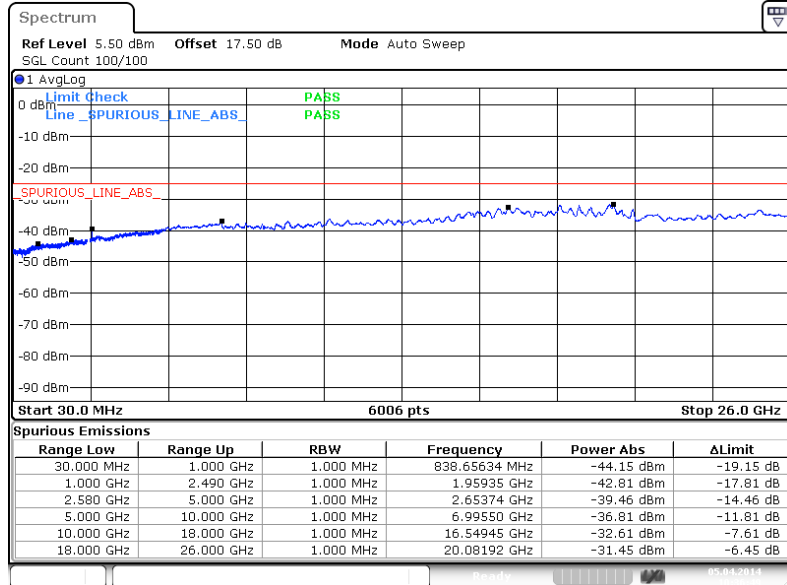

16QAM (RB Size 1, RB Offset 49)

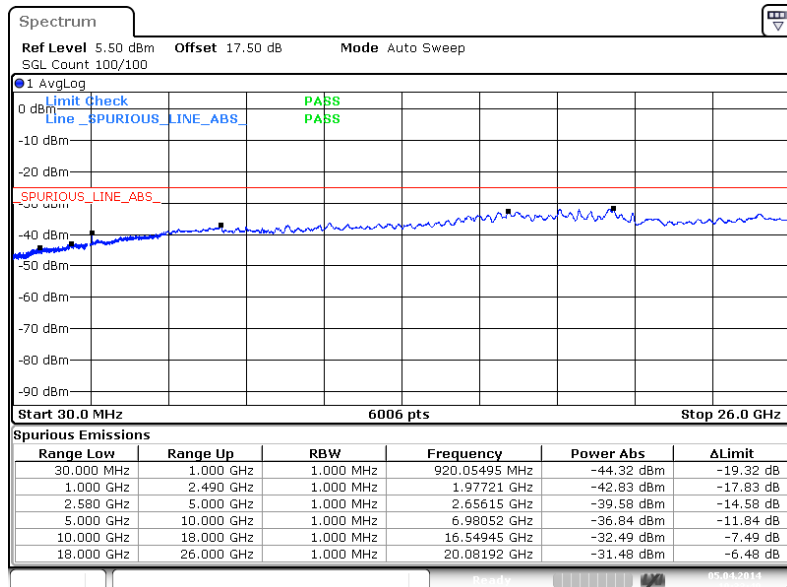



Band :	LTE Band 7	Channel :	CH21400 (High)
Band Width :	10MHz		

QPSK (RB Size 1, RB Offset 24)

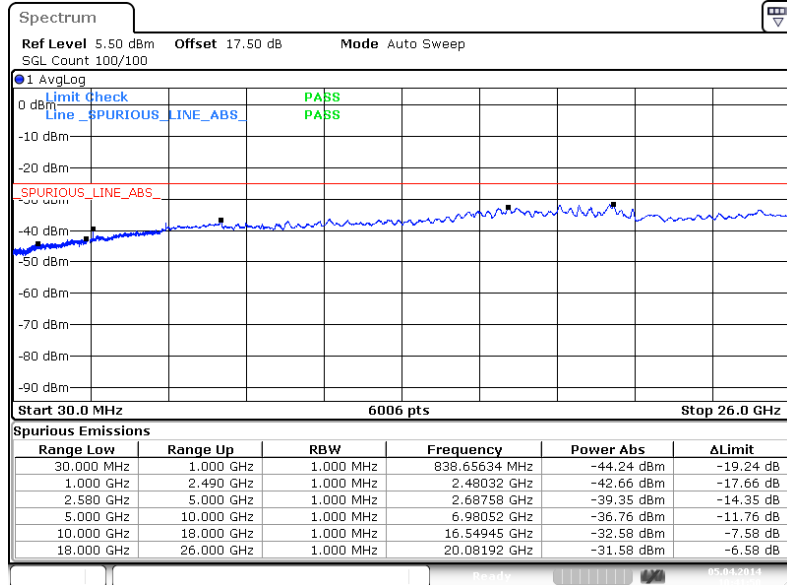

16QAM (RB Size 1, RB Offset 0)

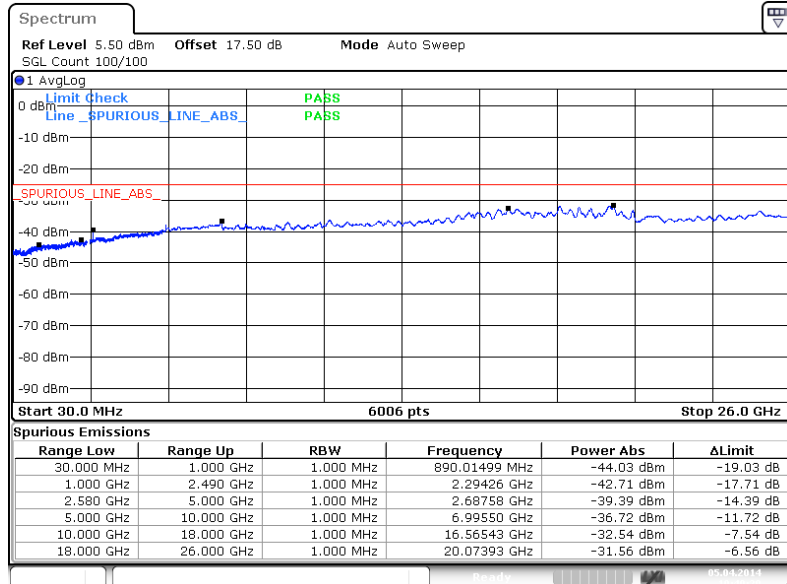



Band :	LTE Band 7	Channel :	CH20825 (Low)
Band Width :	15MHz		

QPSK (RB Size 1, RB Offset 0)

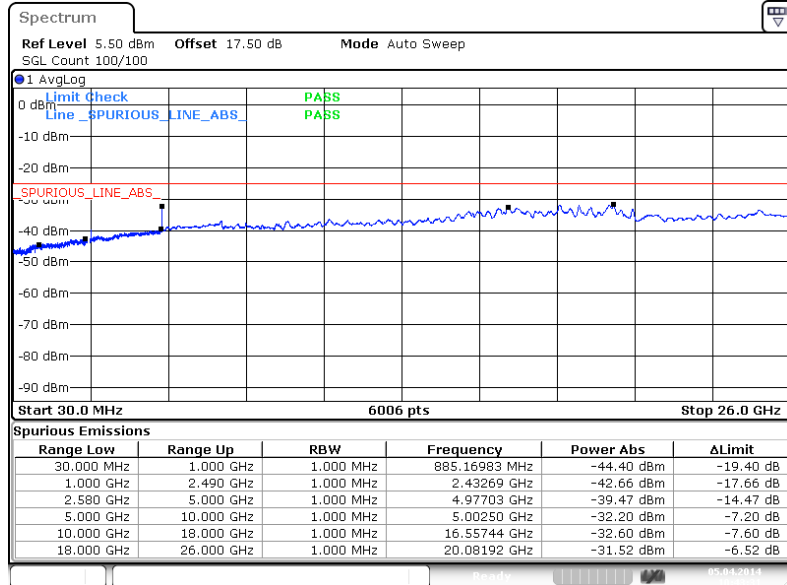

16QAM (RB Size 1, RB Offset 37)

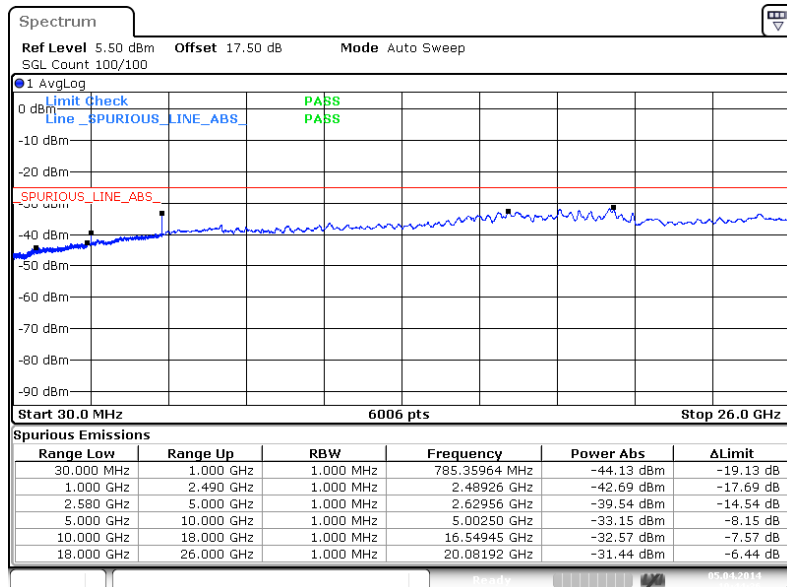



Band :	LTE Band 7	Channel :	CH21100 (Middle)
Band Width :	15MHz		

QPSK (RB Size 1, RB Offset 74)

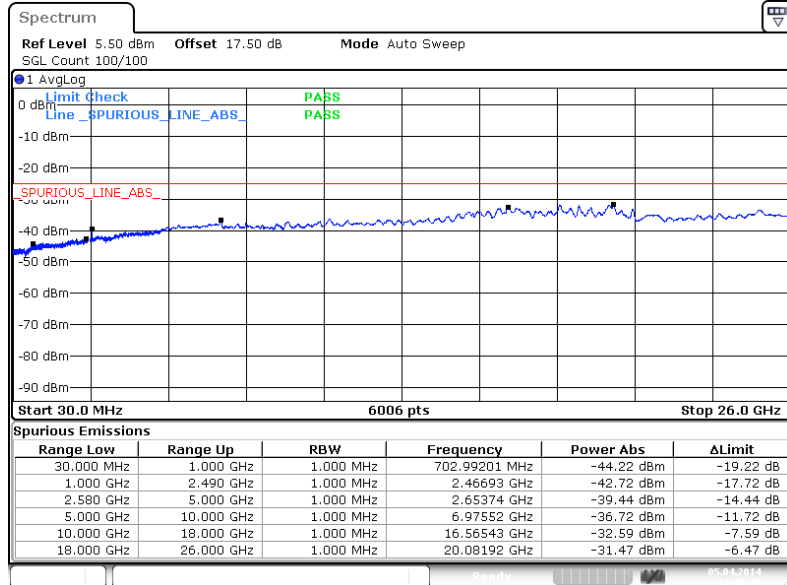

16QAM (RB Size 1, RB Offset 74)

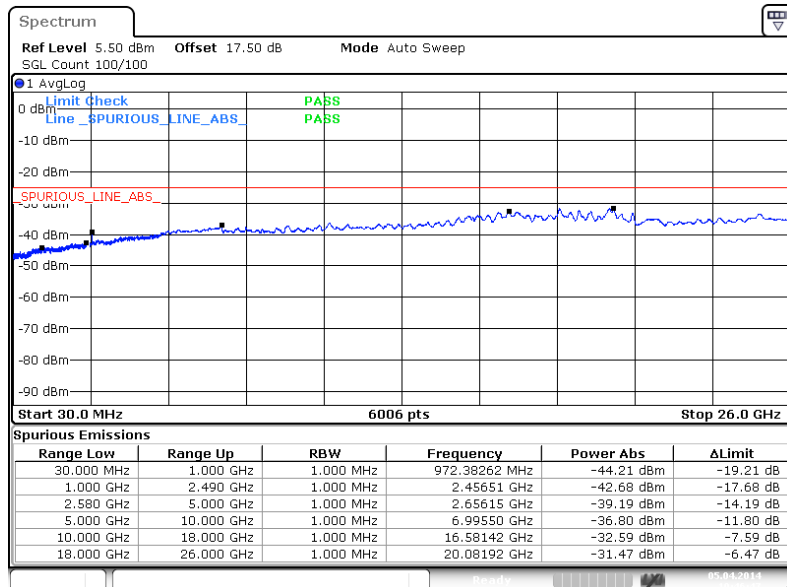



Band :	LTE Band 7	Channel :	CH21375 (High)
Band Width :	15MHz		

QPSK (RB Size 1, RB Offset 74)

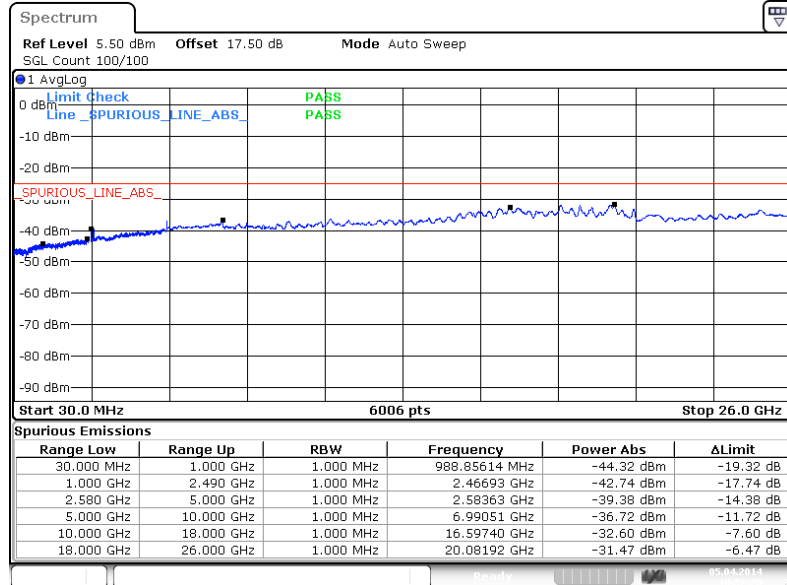

16QAM (RB Size 1, RB Offset 0)

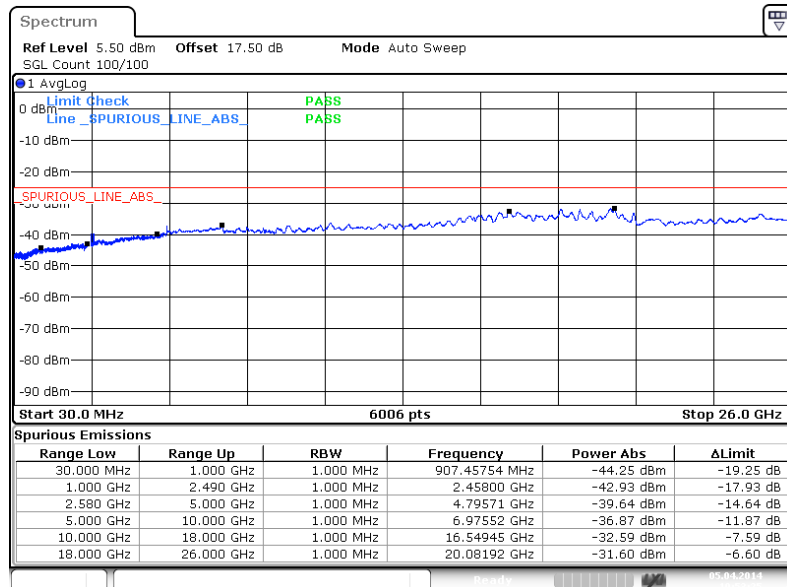



Band :	LTE Band 7	Channel :	CH20850 (Low)
Band Width :	20MHz		

QPSK (RB Size 1, RB Offset 0)

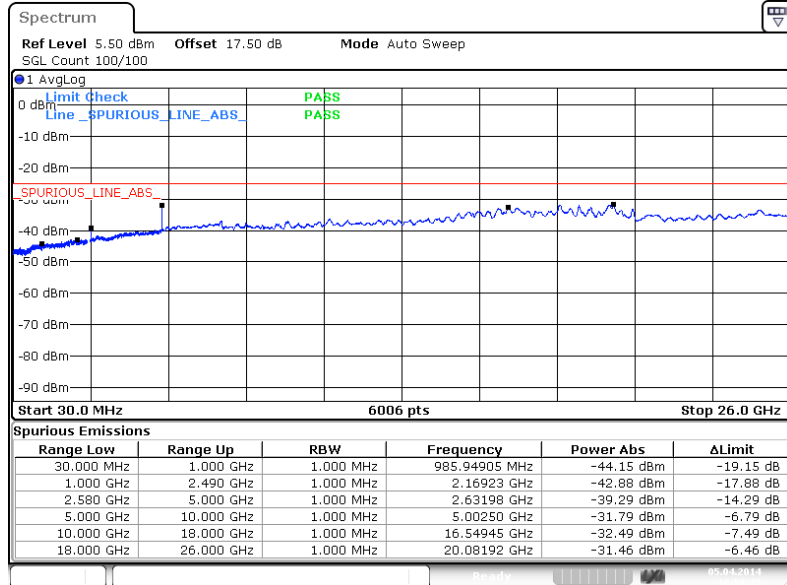

16QAM (RB Size 1, RB Offset 99)

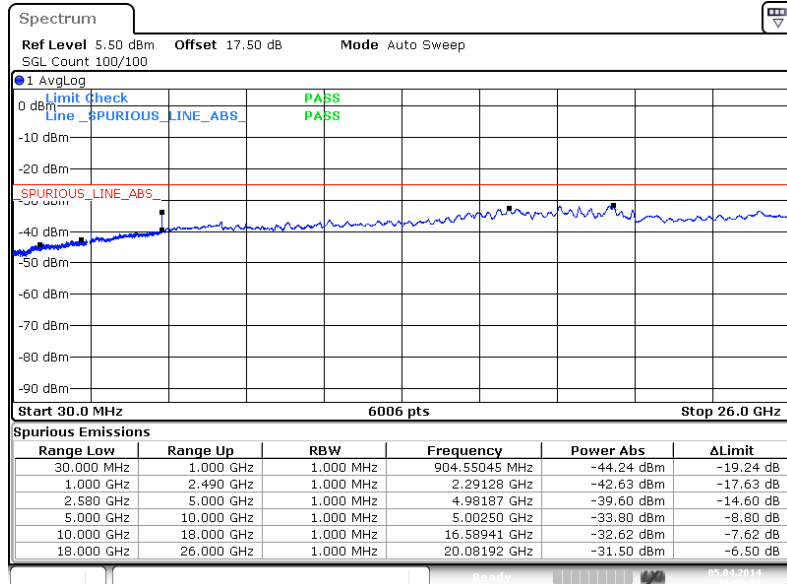



Band :	LTE Band 7	Channel :	CH21100 (Middle)
Band Width :	20MHz		

QPSK (RB Size 1, RB Offset 49)

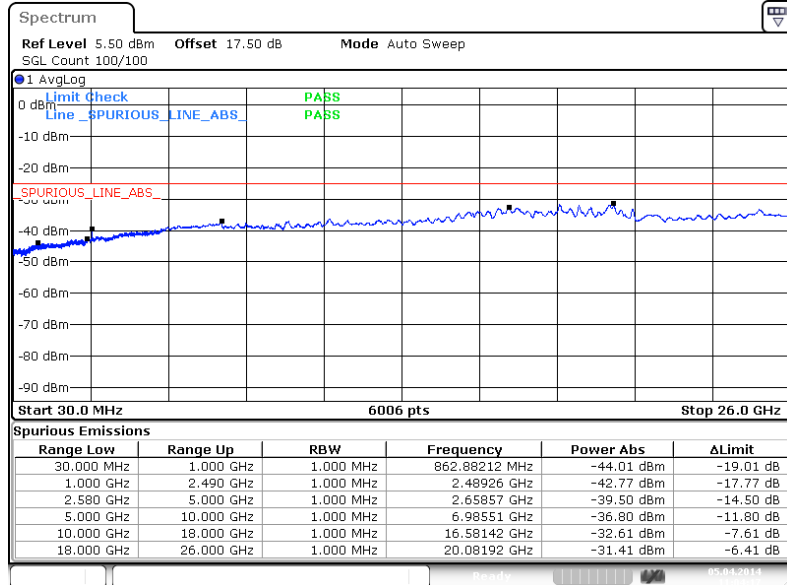

16QAM (RB Size 1, RB Offset 0)

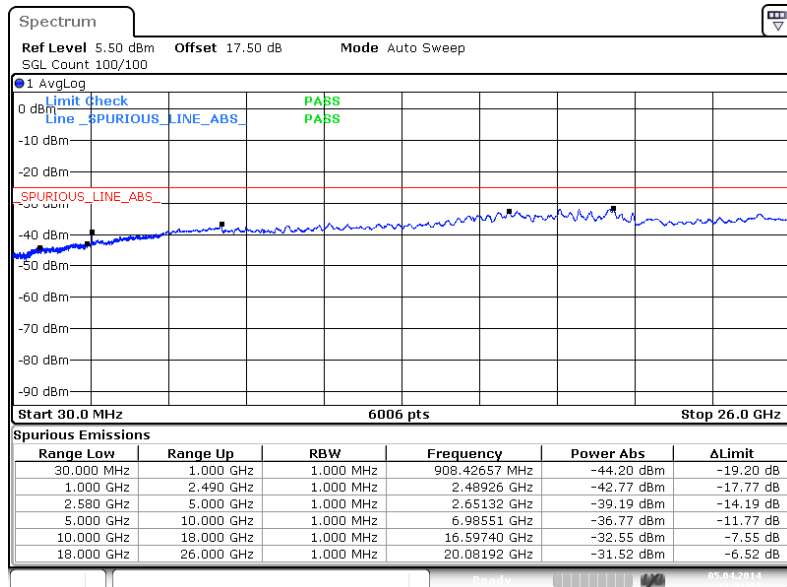



Band :	LTE Band 7	Channel :	CH21350 (High)
Band Width :	20MHz		

QPSK (RB Size 1, RB Offset 49)

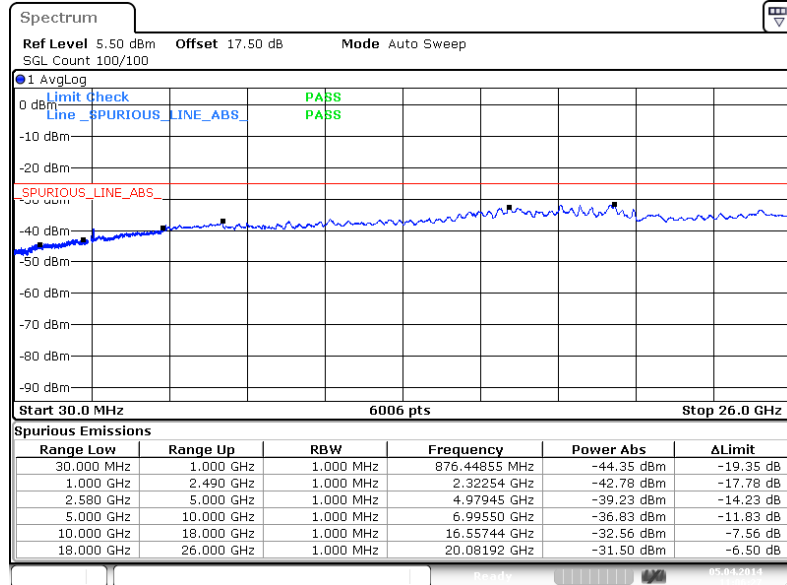

16QAM (RB Size 1, RB Offset 99)

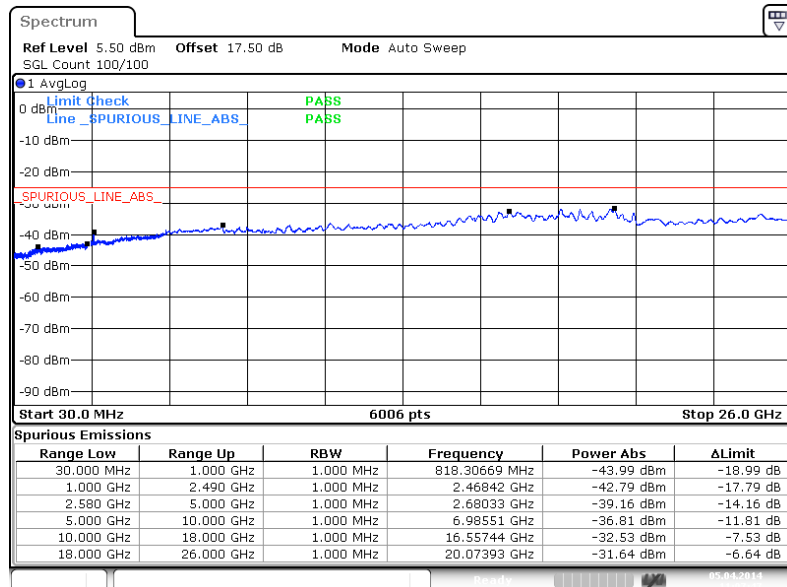



3.7 Radiated Spurious Emission Measurement

3.7.1 Description of Radiated Spurious Emission

The radiated spurious emission was measured by substitution method according to ANSI / TIA / EIA-603-C-2004.

For Band 4

The power of any emission outside of the authorized operating frequency ranges must be attenuated below the transmitter power (P) by a factor of at least $43 + 10 \log (P)$ dB.

For Band 7

The power of any emission outside of the authorized operating frequency ranges must be attenuated below the transmitter power (P) by a factor of at least $55 + 10 \log (P)$ dB.

The spectrum is scanned from 30 MHz up to a frequency including its 10th harmonic.

3.7.2 Measuring Instruments

The measuring equipment is listed in the section 4 of this test report.

3.7.3 Test Procedures

1. The EUT was placed on a rotatable wooden table with 0.8 meter above ground.
2. The EUT was set 3 meters from the receiving antenna, which was mounted on the antenna tower.
3. The table was rotated 360 degrees to determine the position of the highest spurious emission.
4. The height of the receiving antenna is varied between one meter and four meters to search the maximum spurious emission for both horizontal and vertical polarizations.
5. Make the measurement with the spectrum analyzer's RBW = 1MHz, VBW = 3MHz, taking the record of maximum spurious emission.
6. A horn antenna was substituted in place of the EUT and was driven by a signal generator.
7. Tune the output power of signal generator to the same emission level with EUT maximum spurious emission.
8. Taking the record of output power at antenna port.
9. Repeat step 7 to step 8 for another polarization.
10. The RF fundamental frequency should be excluded against the limit line in the operating frequency band.

For Band 4

The limit line is derived from $43 + 10\log(P)$ dB below the transmitter power P(Watts)

$$= P(W) - [43 + 10\log(P)] \text{ (dB)}$$

$$= [30 + 10\log(P)] \text{ (dBm)} - [43 + 10\log(P)] \text{ (dB)}$$

$$= -13\text{dBm.}$$

For Band 7

The limit line is derived from $55 + 10\log(P)$ dB below the transmitter power P(Watts)

$$= P(W) - [55 + 10\log(P)] \text{ (dB)}$$

$$= [30 + 10\log(P)] \text{ (dBm)} - [55 + 10\log(P)] \text{ (dB)}$$

$$= -25\text{dBm.}$$

11. EIRP (dBm) = S.G. Power – Tx Cable Loss + Tx Antenna Gain

3.7.4 Test Setup

For radiated emissions from 30MHz to 1GHz

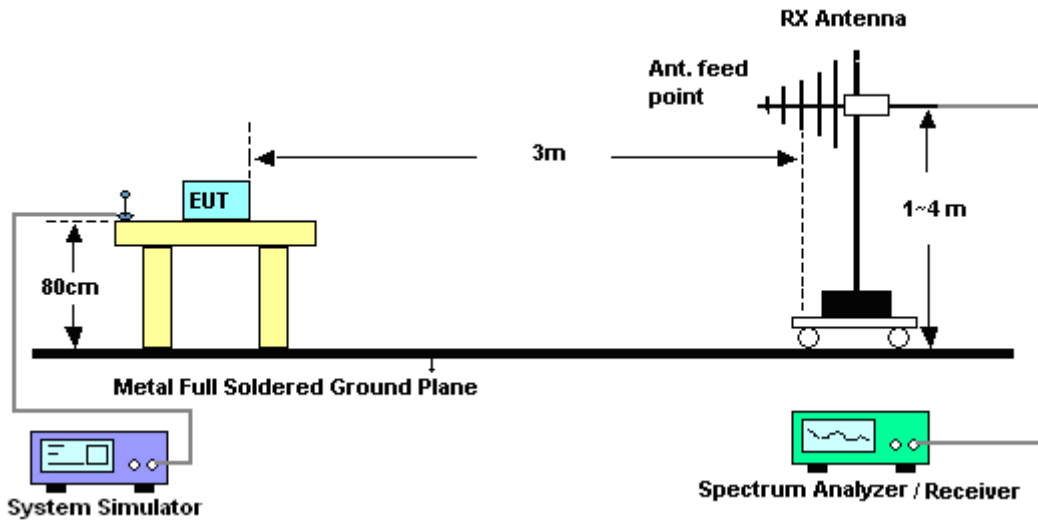

For radiated emissions above 1GHz

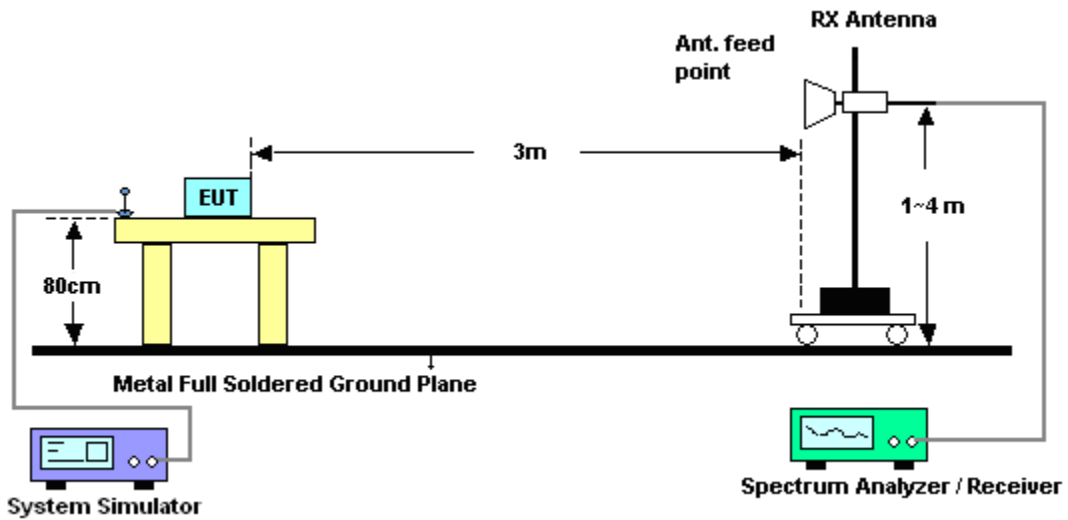



3.7.5 Test Result of Field Strength of Spurious Radiated

Band :	LTE Band 4	Temperature :	23~25°C
Test Mode :	1.4MHz QPSK RB Size 1 Offset 0	Relative Humidity :	48~52%
Test Engineer :	Kaer Huang	Polarization :	Horizontal
Remark :	Spurious emissions within 30-10th harmonic were found more than 20dB below limit line.		

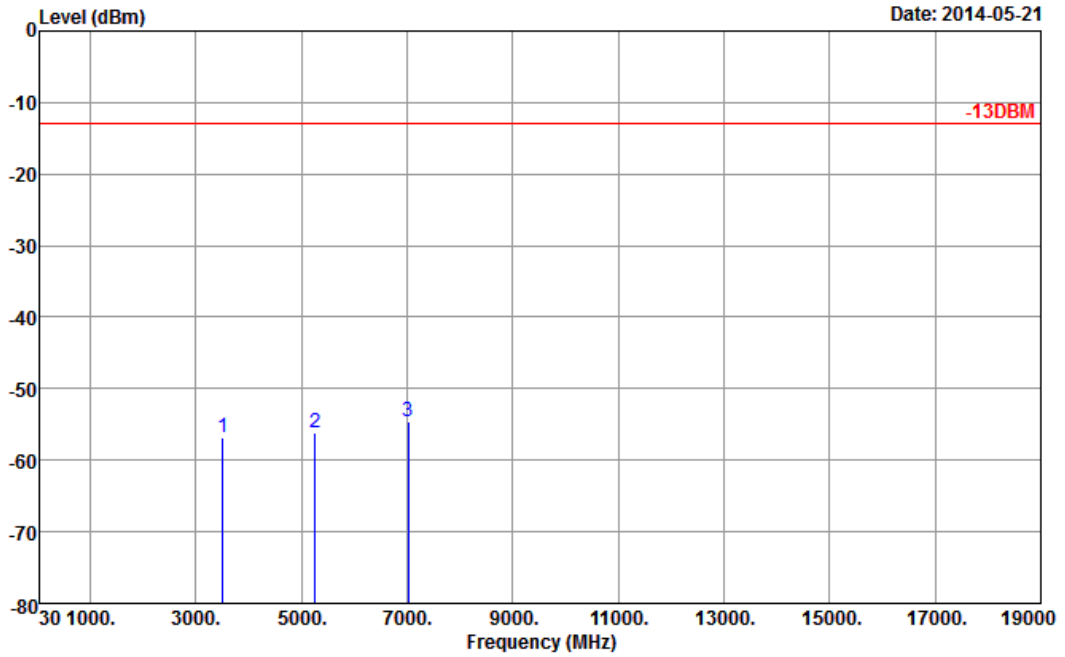

Site : 03CH01-SZ
 Condition : -13DBM HF_EIRP_H_130101 HORIZONTAL

Frequency (MHz)	EIRP (dBm)	Limit (dBm)	Over Limit (dB)	SPA Reading (dBm)	S.G. Power (dBm)	TX Cable loss (dB)	TX Antenna Gain (dBi)	Polarization (H/V)	Result
3508	-56.75	-13	-43.75	-69.42	-63.75	1.3	8.30	H	Pass
5262	-56.12	-13	-43.12	-73.85	-64.64	1.6	10.12	H	Pass
7016	-54.52	-13	-41.52	-76.26	-64.92	1.7	12.10	H	Pass



Band :	LTE Band 4	Temperature :	23~25°C
Test Mode :	1.4MHz QPSK RB Size 1 Offset 0	Relative Humidity :	48~52%
Test Engineer :	Kaer Huang	Polarization :	Vertical
Remark :	Spurious emissions within 30-10th harmonic were found more than 20dB below limit line.		

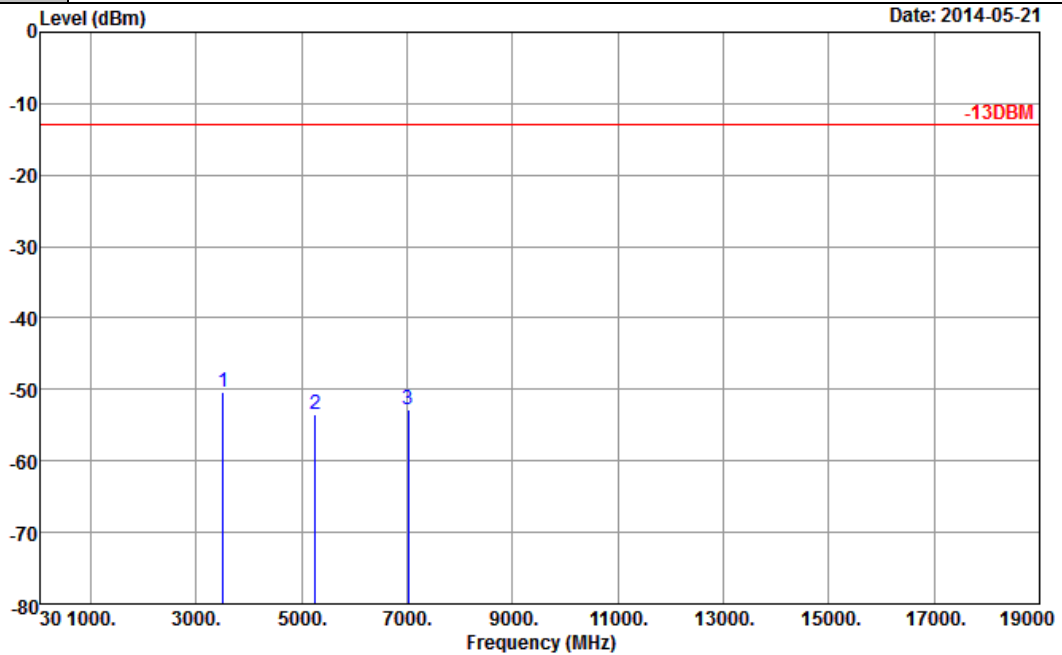

Site : 03CH01-SZ
 Condition : -13DBM HF_EIRP_V_130101 VERTICAL

Frequency (MHz)	EIRP (dBm)	Limit (dBm)	Over Limit (dB)	SPA Reading (dBm)	S.G. Power (dBm)	TX Cable loss (dB)	TX Antenna Gain (dBi)	Polarization (H/V)	Result
3508	-50.35	-13	-37.35	-65.9	-57.35	1.3	8.3	V	Pass
5262	-53.59	-13	-40.59	-70.41	-62.11	1.6	10.12	V	Pass
7016	-52.79	-13	-39.79	-74.84	-63.19	1.7	12.1	V	Pass



Band :	LTE Band 4	Temperature :	23~25°C
Test Mode :	3MHz QPSK RB Size 1 Offset 0	Relative Humidity :	48~52%
Test Engineer :	Kaer Huang	Polarization :	Horizontal
Remark :	Spurious emissions within 30-10th harmonic were found more than 20dB below limit line.		

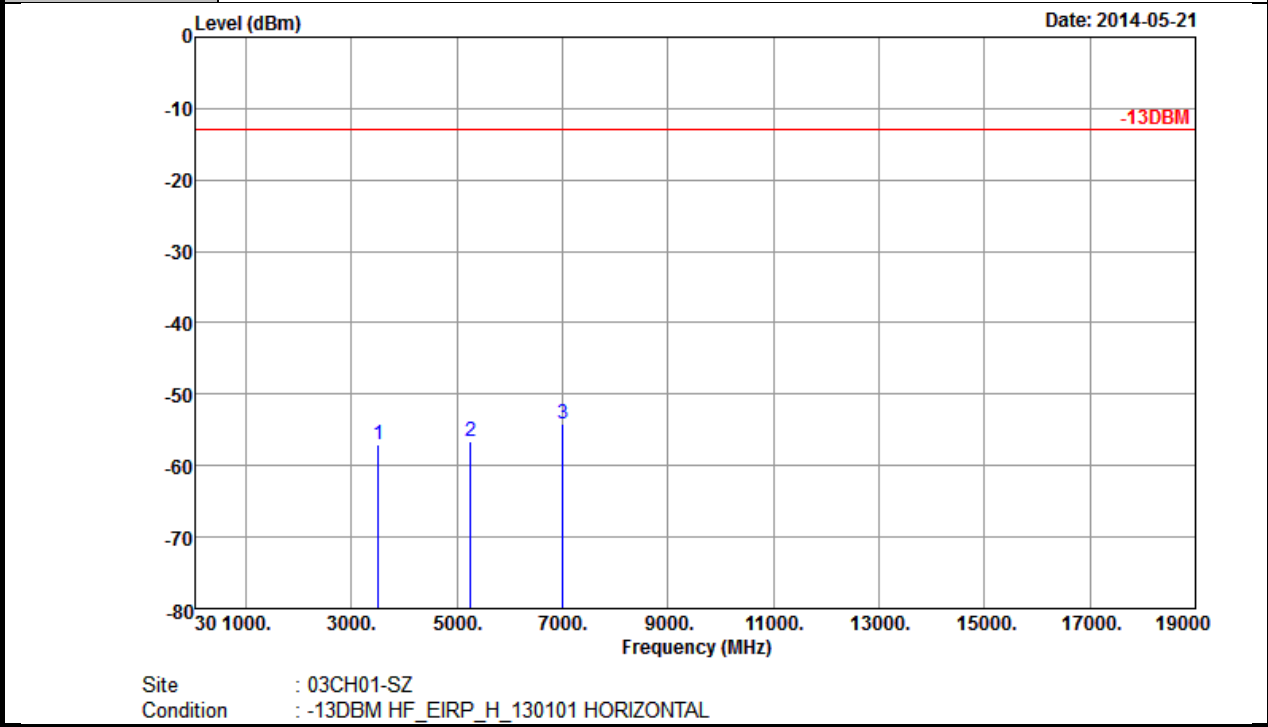

Frequency (MHz)	EIRP (dBm)	Limit (dBm)	Over Limit (dB)	SPA Reading (dBm)	S.G. Power (dBm)	TX Cable loss (dB)	TX Antenna Gain (dBi)	Polarization (H/V)	Result
3504	-57.15	-13	-44.15	-69.82	-64.15	1.3	8.30	H	Pass
5256	-56.60	-13	-43.60	-74.33	-65.12	1.6	10.12	H	Pass
7008	-54.07	-13	-41.07	-75.81	-64.47	1.7	12.10	H	Pass



Band :	LTE Band 4	Temperature :	23~25°C
Test Mode :	3MHz QPSK RB Size 1 Offset 0	Relative Humidity :	48~52%
Test Engineer :	Kaer Huang	Polarization :	Vertical
Remark :	Spurious emissions within 30-10th harmonic were found more than 20dB below limit line.		

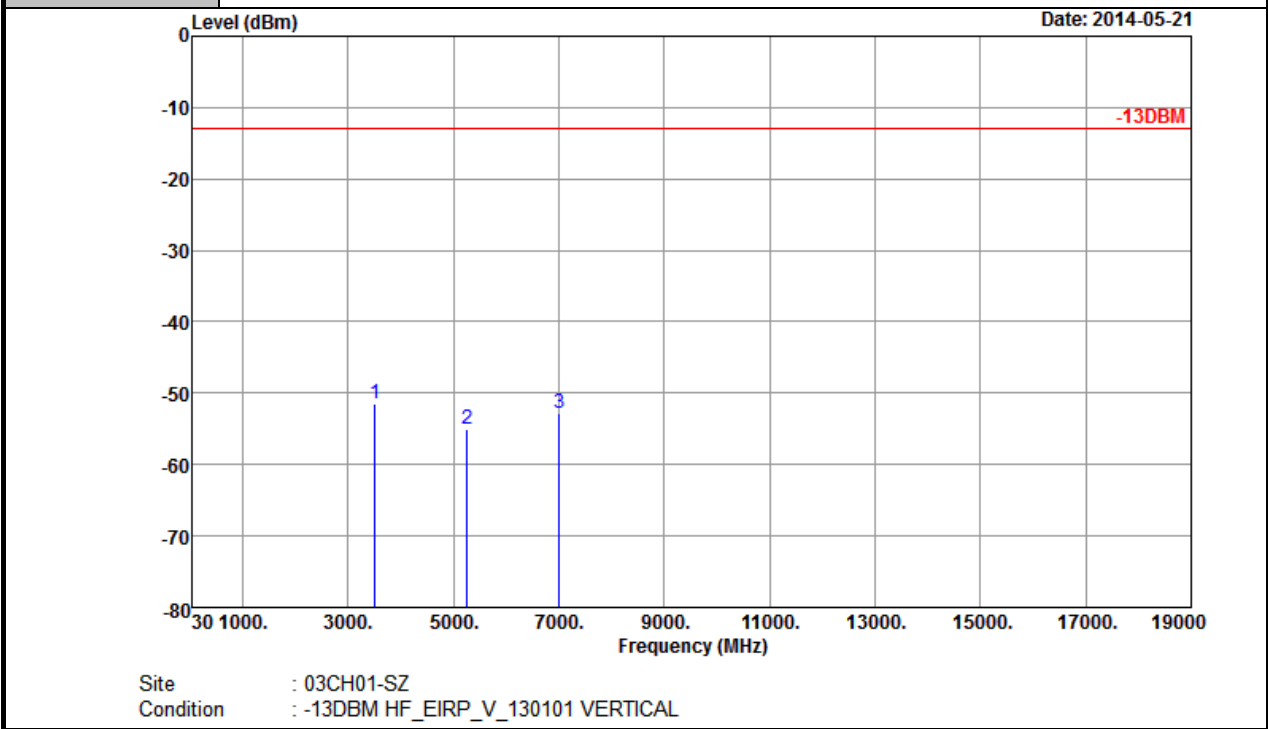

Frequency (MHz)	EIRP (dBm)	Limit (dBm)	Over Limit (dB)	SPA Reading (dBm)	S.G. Power (dBm)	TX Cable loss (dB)	TX Antenna Gain (dBi)	Polarization (H/V)	Result
3504	-51.53	-13	-38.53	-67.08	-58.53	1.3	8.3	V	Pass
5256	-54.97	-13	-41.97	-71.79	-63.49	1.6	10.12	V	Pass
7008	-52.89	-13	-39.89	-74.94	-63.29	1.7	12.1	V	Pass



Band :	LTE Band 4	Temperature :	23~25°C
Test Mode :	5MHz QPSK RB Size 1 Offset 24	Relative Humidity :	48~52%
Test Engineer :	Kaer Huang	Polarization :	Horizontal
Remark :	Spurious emissions within 30-10th harmonic were found more than 20dB below limit line.		

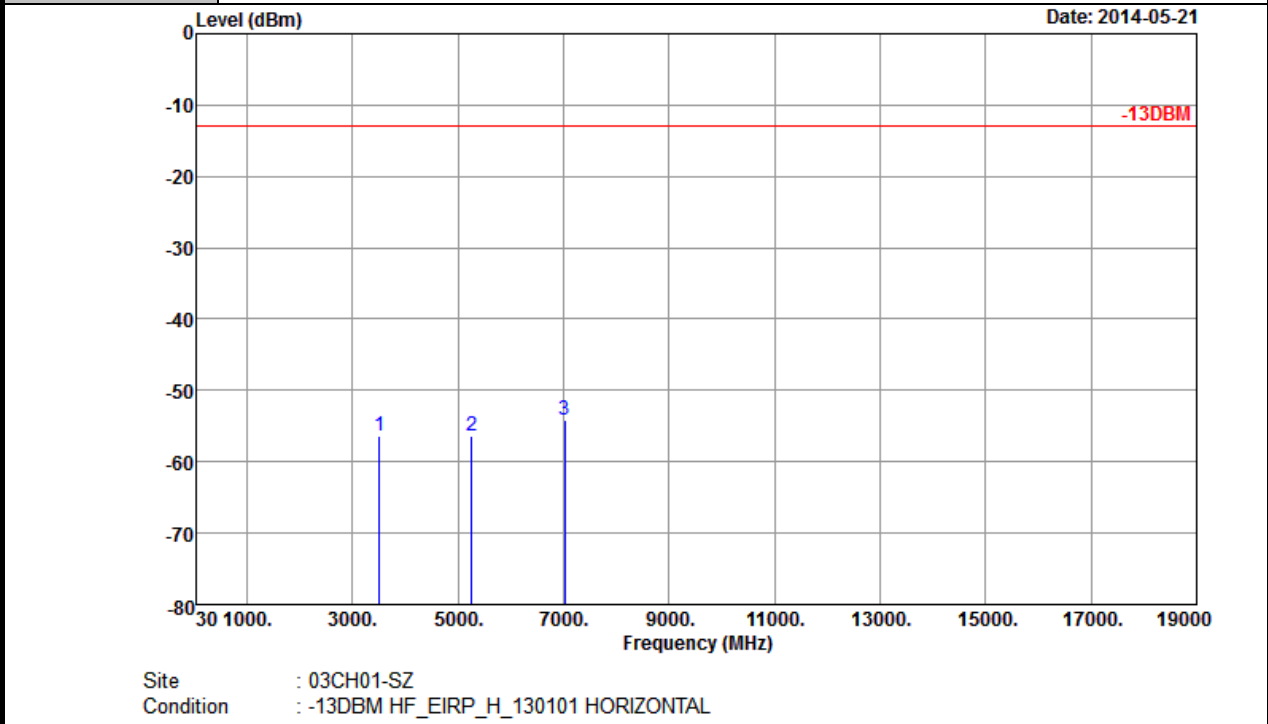

Frequency (MHz)	EIRP (dBm)	Limit (dBm)	Over Limit (dB)	SPA Reading (dBm)	S.G. Power (dBm)	TX Cable loss (dB)	TX Antenna Gain (dBi)	Polarization (H/V)	Result
3508	-56.38	-13	-43.38	-69.05	-63.38	1.3	8.30	H	Pass
5262	-56.30	-13	-43.30	-74.03	-64.82	1.6	10.12	H	Pass
7016	-54.15	-13	-41.15	-75.89	-64.55	1.7	12.10	H	Pass



Band :	LTE Band 4	Temperature :	23~25°C
Test Mode :	5MHz QPSK RB Size 1 Offset 24	Relative Humidity :	48~52%
Test Engineer :	Kaer Huang	Polarization :	Vertical
Remark :	Spurious emissions within 30-10th harmonic were found more than 20dB below limit line.		

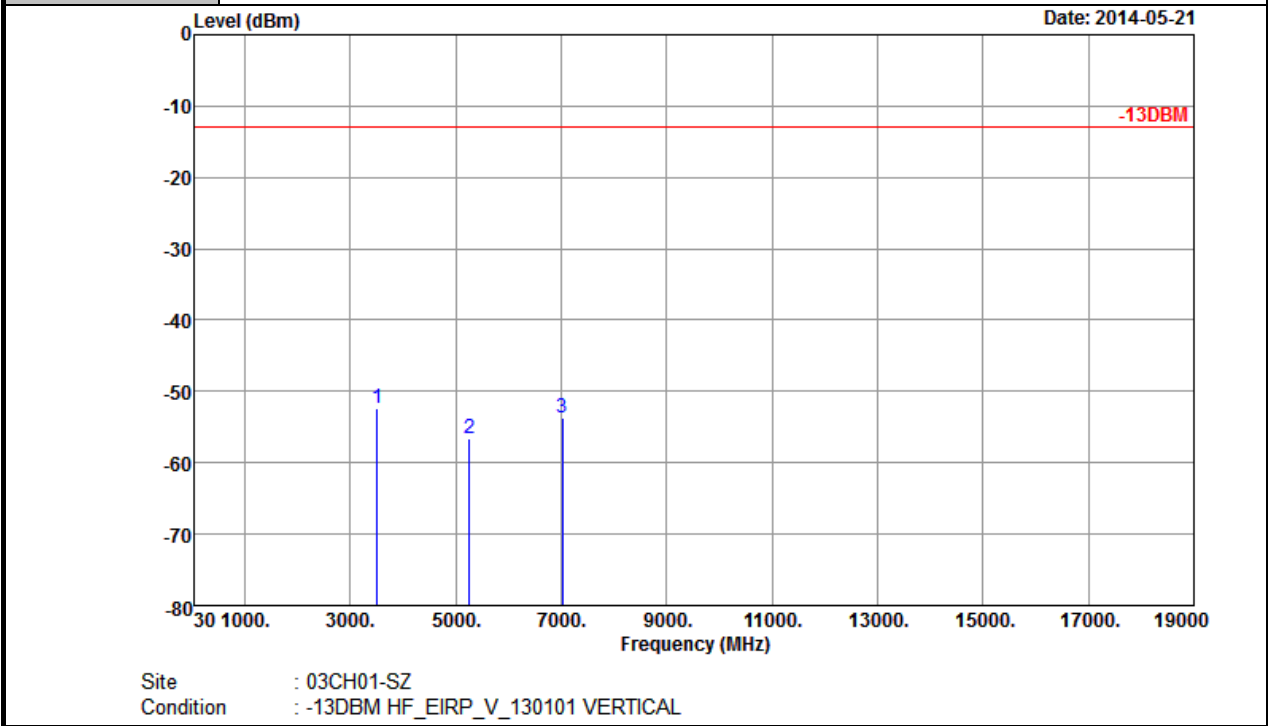

Frequency (MHz)	EIRP (dBm)	Limit (dBm)	Over Limit (dB)	SPA Reading (dBm)	S.G. Power (dBm)	TX Cable loss (dB)	TX Antenna Gain (dBi)	Polarization (H/V)	Result
3508	-52.40	-13	-39.40	-67.95	-59.40	1.3	8.3	V	Pass
5262	-56.59	-13	-43.59	-73.41	-65.11	1.6	10.12	V	Pass
7016	-53.67	-13	-40.67	-75.72	-64.07	1.7	12.1	V	Pass



Band :	LTE Band 4	Temperature :	23~25°C
Test Mode :	10MHz QPSK RB Size 1 Offset 24	Relative Humidity :	48~52%
Test Engineer :	Kaer Huang	Polarization :	Horizontal
Remark :	Spurious emissions within 30-10th harmonic were found more than 20dB below limit line.		

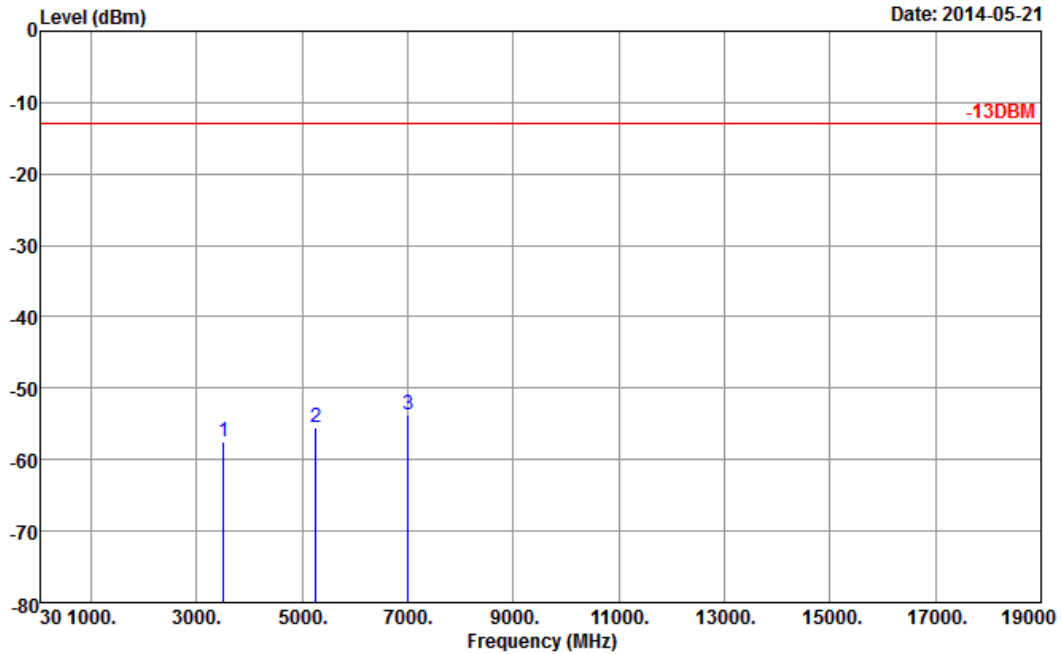

Site : 03CH01-SZ
 Condition : -13DBM HF_EIRP_H_130101 HORIZONTAL

Frequency (MHz)	EIRP (dBm)	Limit (dBm)	Over Limit (dB)	SPA Reading (dBm)	S.G. Power (dBm)	TX Cable loss (dB)	TX Antenna Gain (dBi)	Polarization (H/V)	Result
3500	-57.59	-13	-44.59	-70.26	-64.59	1.3	8.30	H	Pass
5250	-55.55	-13	-42.55	-73.28	-64.07	1.6	10.12	H	Pass
7000	-53.64	-13	-40.64	-75.38	-64.04	1.7	12.10	H	Pass



Band :	LTE Band 4	Temperature :	23~25°C
Test Mode :	10MHz QPSK RB Size 1 Offset 24	Relative Humidity :	48~52%
Test Engineer :	Kaer Huang	Polarization :	Vertical
Remark :	Spurious emissions within 30-10th harmonic were found more than 20dB below limit line.		

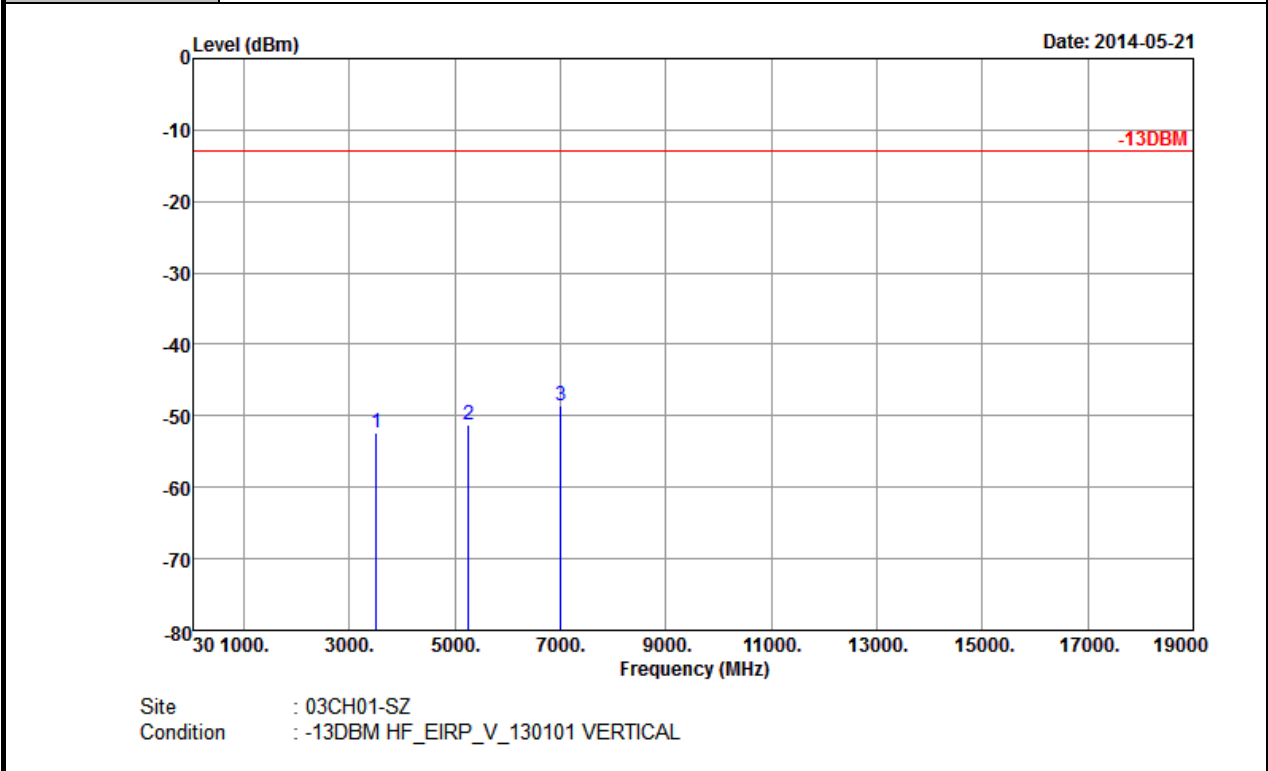

Frequency (MHz)	EIRP (dBm)	Limit (dBm)	Over Limit (dB)	SPA Reading (dBm)	S.G. Power (dBm)	TX Cable loss (dB)	TX Antenna Gain (dBi)	Polarization (H/V)	Result
3500	-52.38	-13	-39.38	-67.93	-59.38	1.3	8.3	V	Pass
5250	-51.17	-13	-38.17	-67.99	-59.69	1.6	10.12	V	Pass
7000	-48.65	-13	-35.65	-70.7	-59.05	1.7	12.1	V	Pass



Band :	LTE Band 4	Temperature :	23~25°C
Test Mode :	15MHz QPSK RB Size 1 Offset 0	Relative Humidity :	48~52%
Test Engineer :	Kaer Huang	Polarization :	Horizontal
Remark :	Spurious emissions within 30-10th harmonic were found more than 20dB below limit line.		

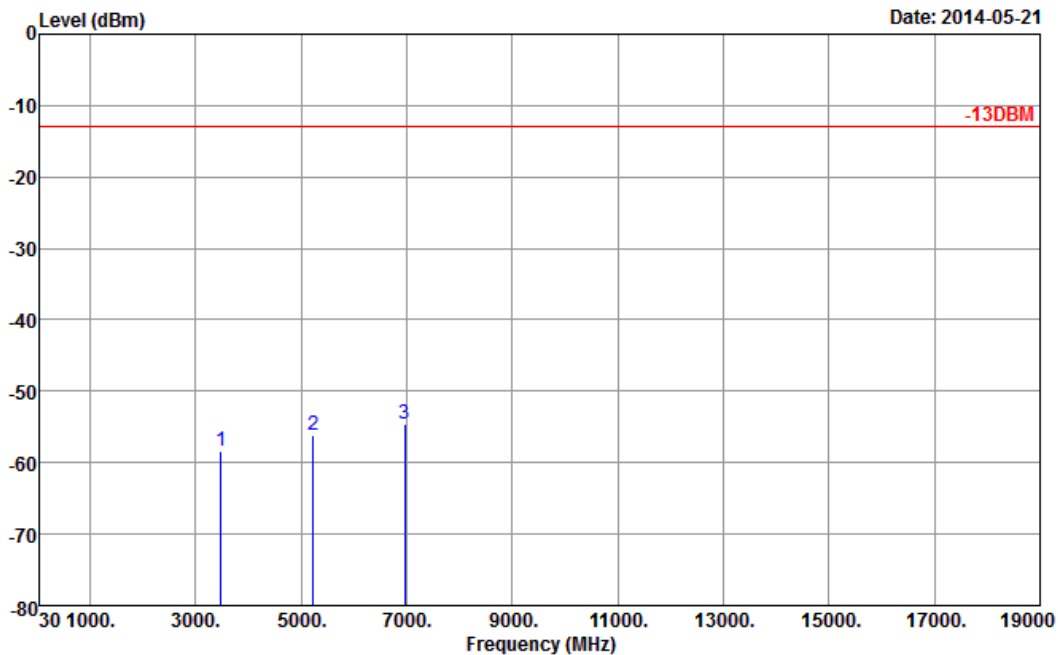

Site : 03CH01-SZ
 Condition : -13DBM HF_EIRP_H_130101 HORIZONTAL

Frequency (MHz)	EIRP (dBm)	Limit (dBm)	Over Limit (dB)	SPA Reading (dBm)	S.G. Power (dBm)	TX Cable loss (dB)	TX Antenna Gain (dBi)	Polarization (H/V)	Result
3480	-58.40	-13	-45.40	-71.07	-65.40	1.3	8.30	H	Pass
5220	-56.25	-13	-43.25	-73.98	-64.77	1.6	10.12	H	Pass
6960	-54.52	-13	-41.52	-76.26	-64.92	1.7	12.10	H	Pass



Band :	LTE Band 4	Temperature :	23~25°C
Test Mode :	15MHz QPSK RB Size 1 Offset 0	Relative Humidity :	48~52%
Test Engineer :	Kaer Huang	Polarization :	Vertical
Remark :	Spurious emissions within 30-10th harmonic were found more than 20dB below limit line.		

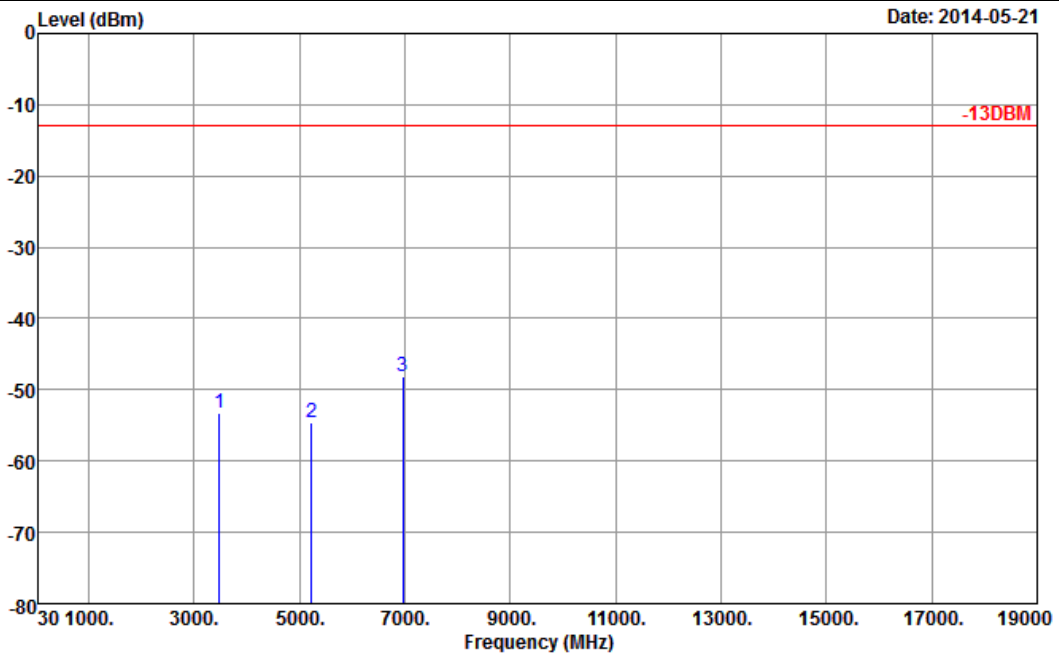

Site : 03CH01-SZ
 Condition : -13DBM HF_EIRP_V_130101 VERTICAL

Frequency (MHz)	EIRP (dBm)	Limit (dBm)	Over Limit (dB)	SPA Reading (dBm)	S.G. Power (dBm)	TX Cable loss (dB)	TX Antenna Gain (dBi)	Polarization (H/V)	Result
3480	-53.31	-13	-40.31	-68.86	-60.31	1.3	8.3	V	Pass
5220	-54.67	-13	-41.67	-71.49	-63.19	1.6	10.12	V	Pass
6960	-48.21	-13	-35.21	-70.26	-58.61	1.7	12.1	V	Pass



Band :	LTE Band 4	Temperature :	23~25°C
Test Mode :	20MHz QPSK RB Size 1 Offset 0	Relative Humidity :	48~52%
Test Engineer :	Kaer Huang	Polarization :	Horizontal
Remark :	Spurious emissions within 30-10th harmonic were found more than 20dB below limit line.		

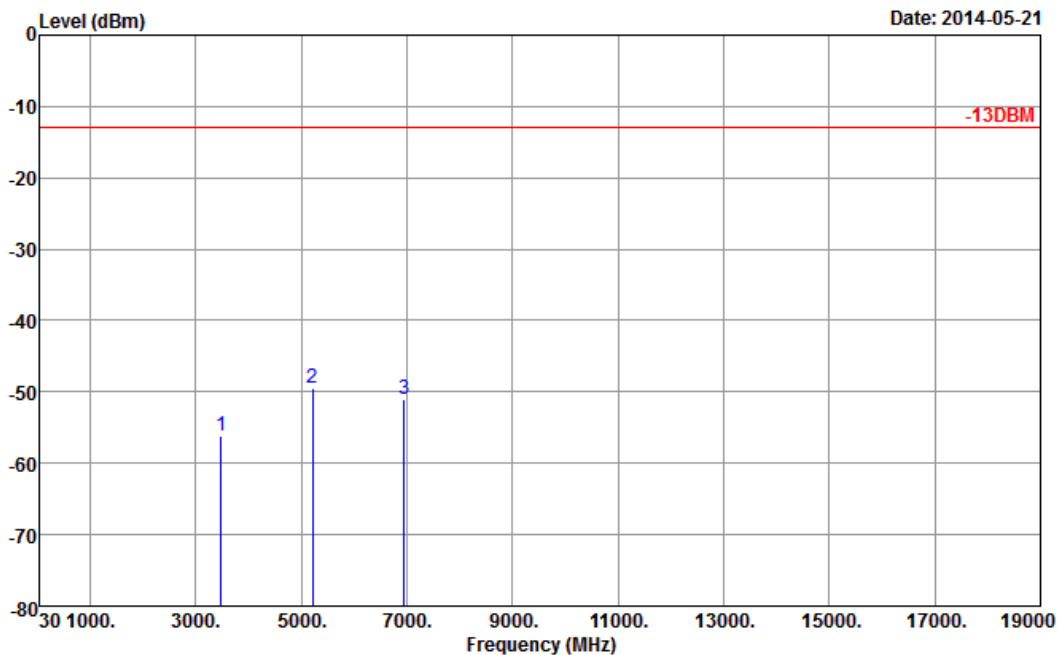

Site : 03CH01-SZ
 Condition : -13DBM HF_EIRP_H_130101 HORIZONTAL

Frequency (MHz)	EIRP (dBm)	Limit (dBm)	Over Limit (dB)	SPA Reading (dBm)	S.G. Power (dBm)	TX Cable loss (dB)	TX Antenna Gain (dBi)	Polarization (H/V)	Result
3490	-56.05	-13	-43.05	-68.72	-63.05	1.3	8.30	H	Pass
5235	-49.49	-13	-36.49	-67.22	-58.01	1.6	10.12	H	Pass
6980	-51.00	-13	-38.00	-72.74	-61.40	1.7	12.10	H	Pass



Band :	LTE Band 4	Temperature :	23~25°C
Test Mode :	20MHz QPSK RB Size 1 Offset 0	Relative Humidity :	48~52%
Test Engineer :	Kaer Huang	Polarization :	Vertical
Remark :	Spurious emissions within 30-10th harmonic were found more than 20dB below limit line.		

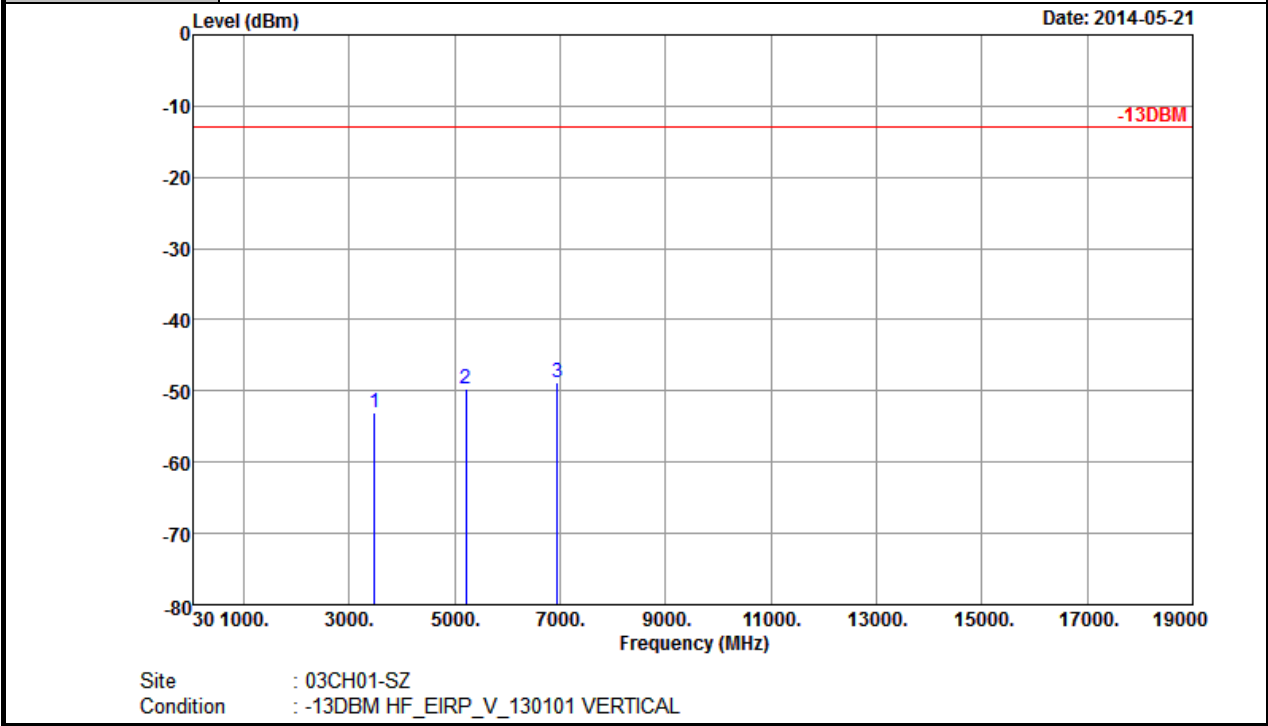

Frequency (MHz)	EIRP (dBm)	Limit (dBm)	Over Limit (dB)	SPA Reading (dBm)	S.G. Power (dBm)	TX Cable loss (dB)	TX Antenna Gain (dBi)	Polarization (H/V)	Result
3490	-53.13	-13	-40.13	-68.68	-60.13	1.3	8.3	V	Pass
5235	-49.75	-13	-36.75	-66.57	-58.27	1.6	10.12	V	Pass
6980	-48.80	-13	-35.80	-70.85	-59.20	1.7	12.1	V	Pass



Band :	LTE Band 7	Temperature :	23~25°C
Test Mode :	5MHz QPSK RB Size 1 Offset 24	Relative Humidity :	48~52%
Test Engineer :	Kaer Huang	Polarization :	Horizontal
Remark :	Spurious emissions within 30-10th harmonic were found more than 20dB below limit line.		

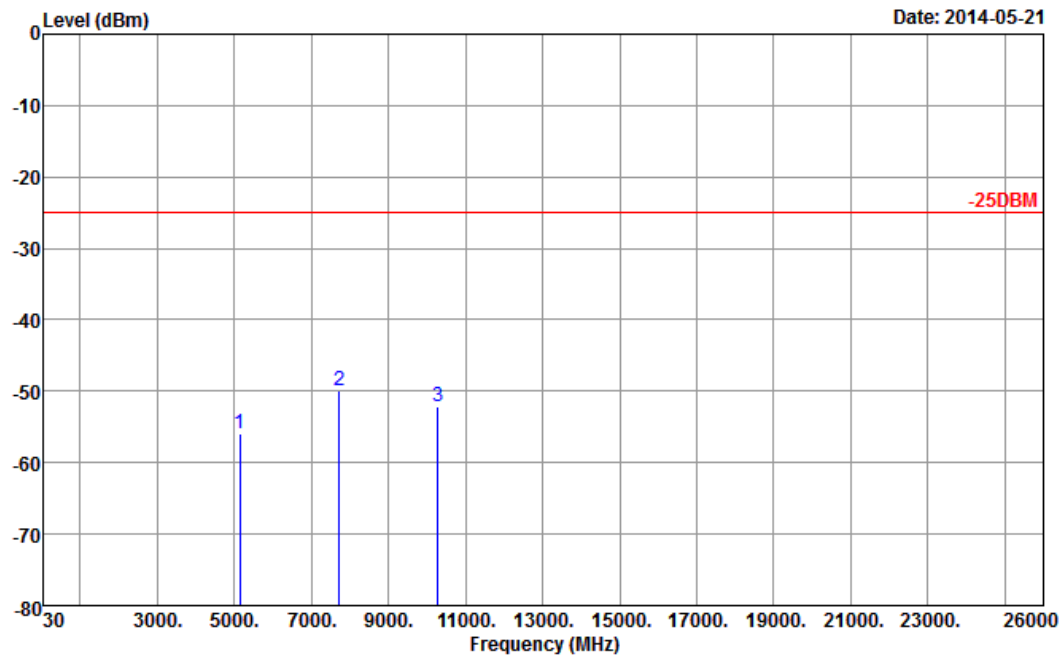

Site : 03CH01-SZ
 Condition : -25DBM HF_EIRP_H_130101 HORIZONTAL

Frequency (MHz)	EIRP (dBm)	Limit (dBm)	Over Limit (dB)	SPA Reading (dBm)	S.G. Power (dBm)	TX Cable loss (dB)	TX Antenna Gain (dBi)	Polarization (H/V)	Result
5140.00	-55.88	-25	-30.88	-66.82	-38.20	1.2	7.60	H	Pass
7710.00	-49.89	-25	-24.89	-68.70	-68.60	1.56	9.90	H	Pass
10280.00	-52.11	-25	-27.11	-75.63	-67.90	1.78	11.60	H	Pass



Band :	LTE Band 7	Temperature :	23~25°C
Test Mode :	5MHz QPSK RB Size 1 Offset 24	Relative Humidity :	48~52%
Test Engineer :	Kaer Huang	Polarization :	Vertical
Remark :	Spurious emissions within 30-10th harmonic were found more than 20dB below limit line.		

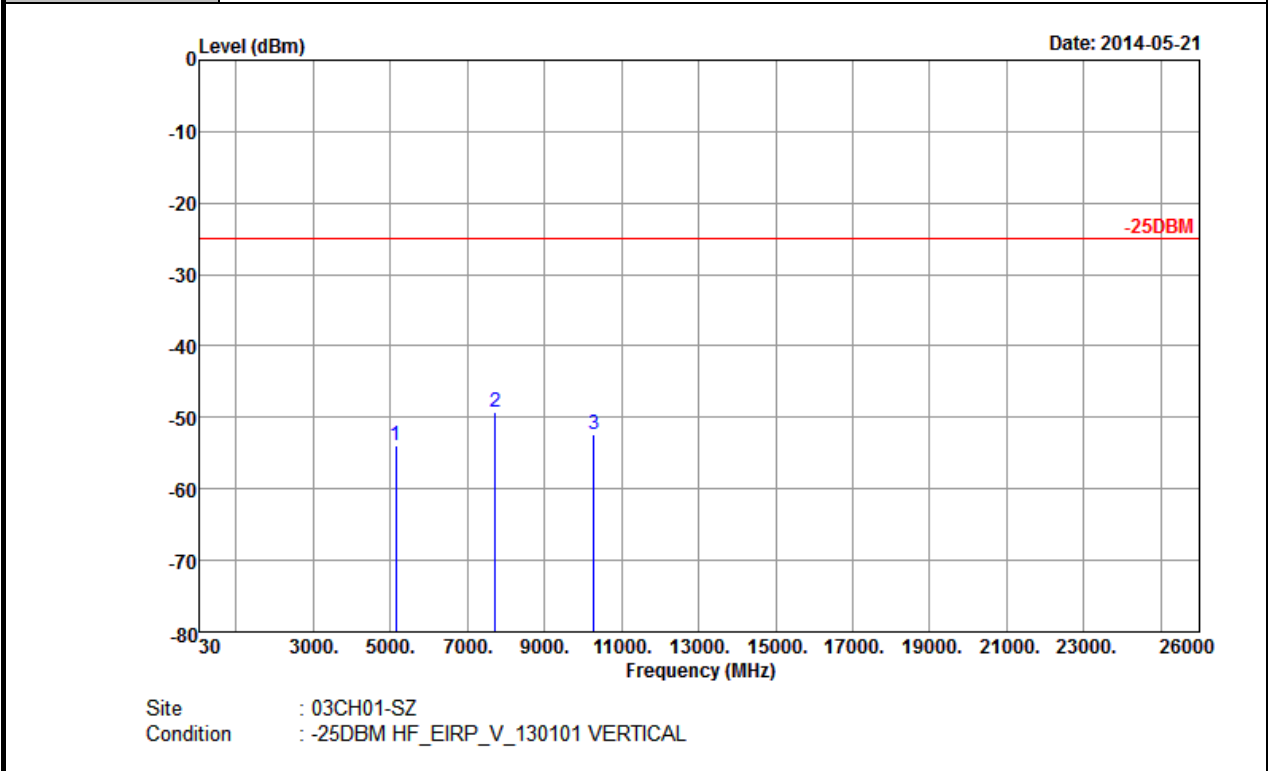

Frequency (MHz)	EIRP (dBm)	Limit (dBm)	Over Limit (dB)	SPA Reading (dBm)	S.G. Power (dBm)	TX Cable loss (dB)	TX Antenna Gain (dBi)	Polarization (H/V)	Result
5140	-54.01	-25.00	-29.01	-66.73	-43.20	1.2	7.60	V	Pass
7710	-49.19	-25.00	-24.19	-68.44	-70.30	1.56	9.90	V	Pass
10280	-52.44	-25.00	-27.44	-75.67	-64.60	1.78	11.60	V	Pass



Band :	LTE Band 7	Temperature :	23~25°C
Test Mode :	10MHz QPSK RB Size 1 Offset 24	Relative Humidity :	48~52%
Test Engineer :	Kaer Huang	Polarization :	Horizontal
Remark :	Spurious emissions within 30-10th harmonic were found more than 20dB below limit line.		

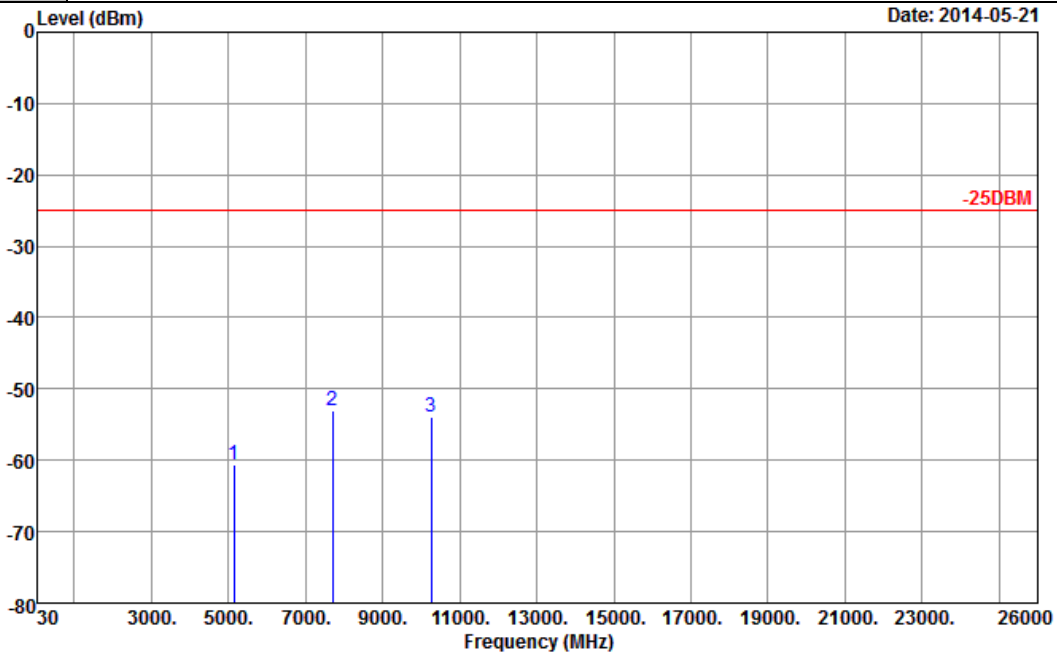

Site : 03CH01-SZ
 Condition : -25DBM HF_EIRP_H_130101 HORIZONTAL

Frequency (MHz)	EIRP (dBm)	Limit (dBm)	Over Limit (dB)	SPA Reading (dBm)	S.G. Power (dBm)	TX Cable loss (dB)	TX Antenna Gain (dBi)	Polarization (H/V)	Result
5130.00	-60.53	-25	-35.53	-71.47	-38.20	1.2	7.60	H	Pass
7695.00	-53.01	-25	-28.01	-71.82	-68.60	1.56	9.90	H	Pass
10260.00	-53.93	-25	-28.93	-77.45	-67.90	1.78	11.60	H	Pass



Band :	LTE Band 7	Temperature :	23~25°C
Test Mode :	10MHz QPSK RB Size 1 Offset 24	Relative Humidity :	48~52%
Test Engineer :	Kaer Huang	Polarization :	Vertical
Remark :	Spurious emissions within 30-10th harmonic were found more than 20dB below limit line.		

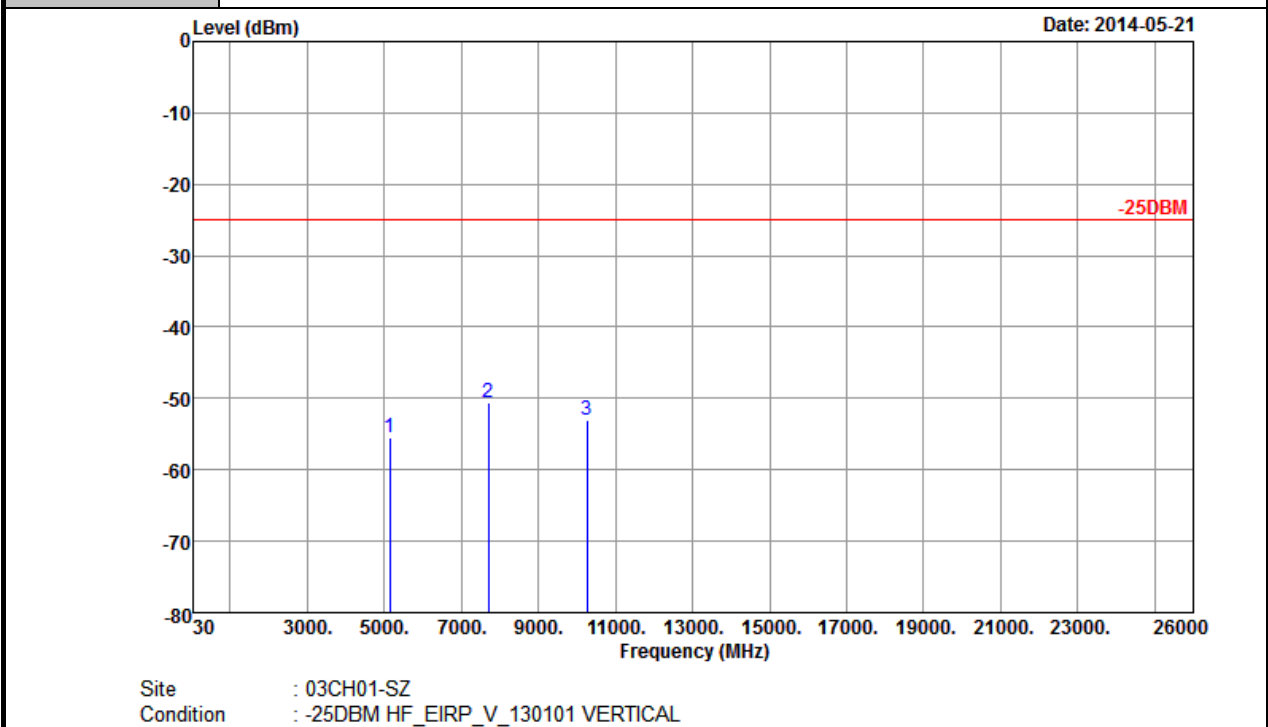

Frequency (MHz)	EIRP (dBm)	Limit (dBm)	Over Limit (dB)	SPA Reading (dBm)	S.G. Power (dBm)	TX Cable loss (dB)	TX Antenna Gain (dBi)	Polarization (H/V)	Result
5130	-55.55	-25	-30.55	-68.27	-43.20	1.2	7.60	V	Pass
7695	-50.61	-25	-25.61	-69.86	-70.30	1.56	9.90	V	Pass
10260	-52.93	-25	-27.93	-76.16	-64.60	1.78	11.60	V	Pass



Band :	LTE Band 7	Temperature :	23~25°C
Test Mode :	15MHz QPSK RB Size 1 Offset 74	Relative Humidity :	48~52%
Test Engineer :	Kaer Huang	Polarization :	Horizontal
Remark :	Spurious emissions within 30-10th harmonic were found more than 20dB below limit line.		

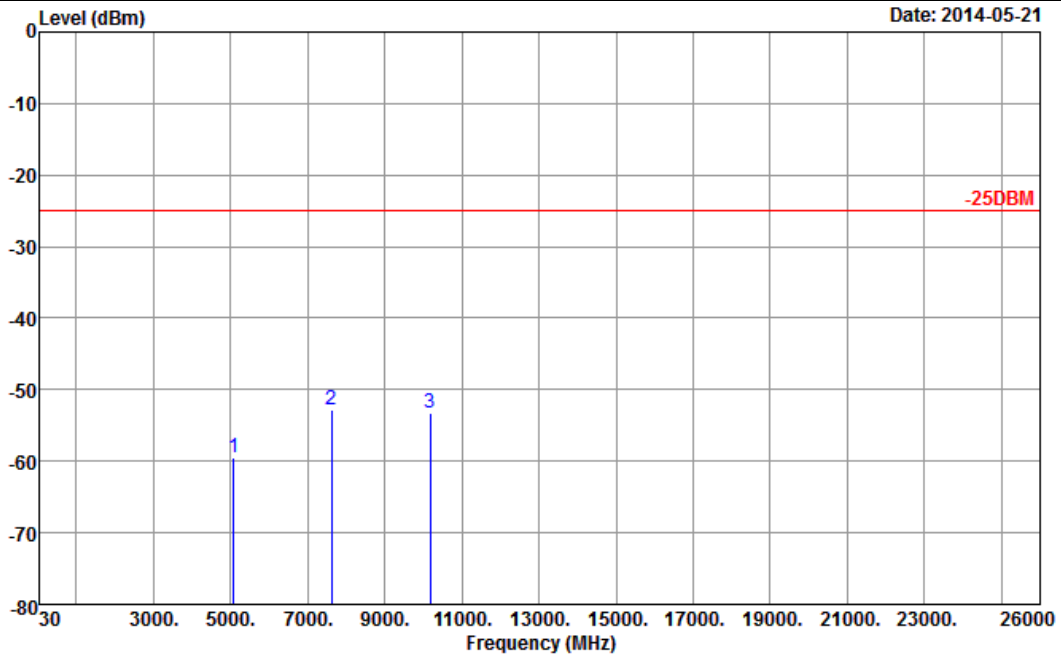

Site : 03CH01-SZ
 Condition : -25DBM HF_EIRP_H_130101 HORIZONTAL

Frequency (MHz)	EIRP (dBm)	Limit (dBm)	Over Limit (dB)	SPA Reading (dBm)	S.G. Power (dBm)	TX Cable loss (dB)	TX Antenna Gain (dBi)	Polarization (H/V)	Result
5084.00	-59.39	-25	-34.39	-70.33	-38.20	1.2	7.60	H	Pass
7626.00	-52.84	-25	-27.84	-71.65	-68.60	1.56	9.90	H	Pass
10168.00	-53.28	-25	-28.28	-76.80	-67.90	1.78	11.60	H	Pass



Band :	LTE Band 7	Temperature :	23~25°C
Test Mode :	15MHz QPSK RB Size 1 Offset 74	Relative Humidity :	48~52%
Test Engineer :	Kaer Huang	Polarization :	Vertical
Remark :	Spurious emissions within 30-10th harmonic were found more than 20dB below limit line.		

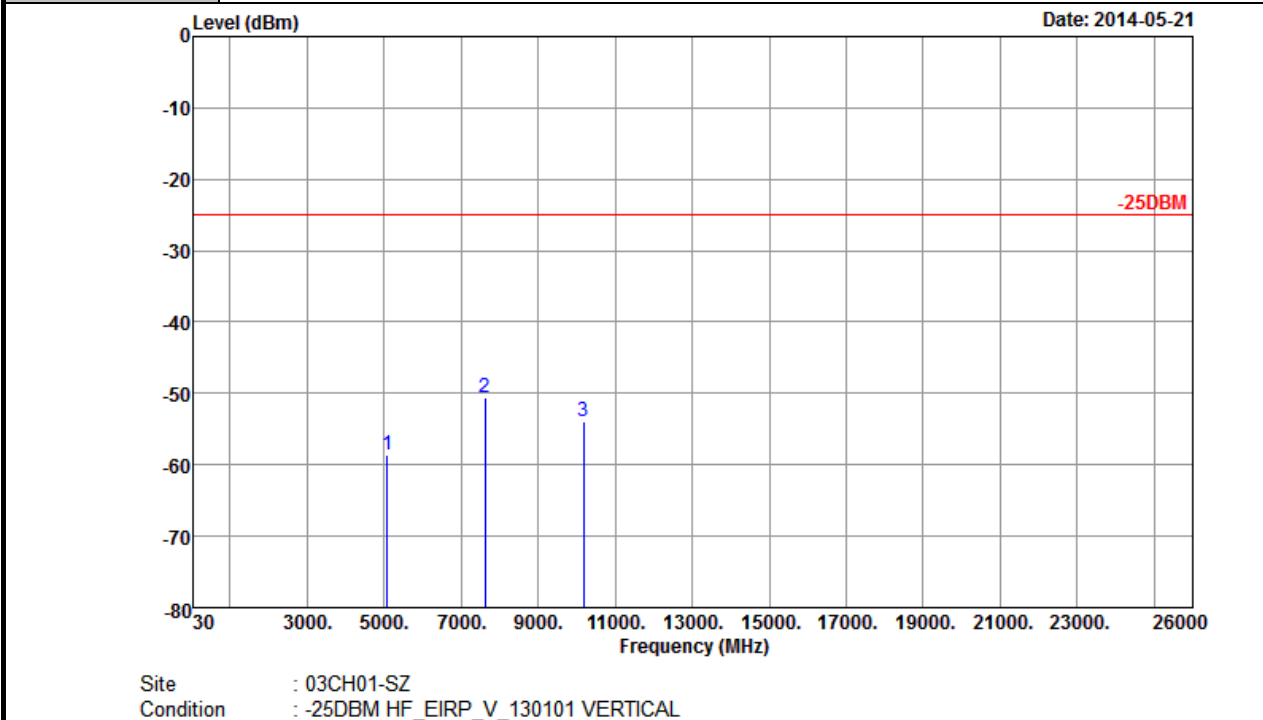

Frequency (MHz)	EIRP (dBm)	Limit (dBm)	Over Limit (dB)	SPA Reading (dBm)	S.G. Power (dBm)	TX Cable loss (dB)	TX Antenna Gain (dBi)	Polarization (H/V)	Result
5084	-58.56	-25	-33.56	-71.28	-43.20	1.2	7.60	V	Pass
7626	-50.57	-25	-25.57	-69.82	-70.30	1.56	9.90	V	Pass
10168	-53.89	-25	-28.89	-77.12	-64.60	1.78	11.60	V	Pass



Band :	LTE Band 7	Temperature :	23~25°C
Test Mode :	20MHz QPSK RB Size 1 Offset 49	Relative Humidity :	48~52%
Test Engineer :	Kaer Huang	Polarization :	Horizontal
Remark :	Spurious emissions within 30-10th harmonic were found more than 20dB below limit line.		

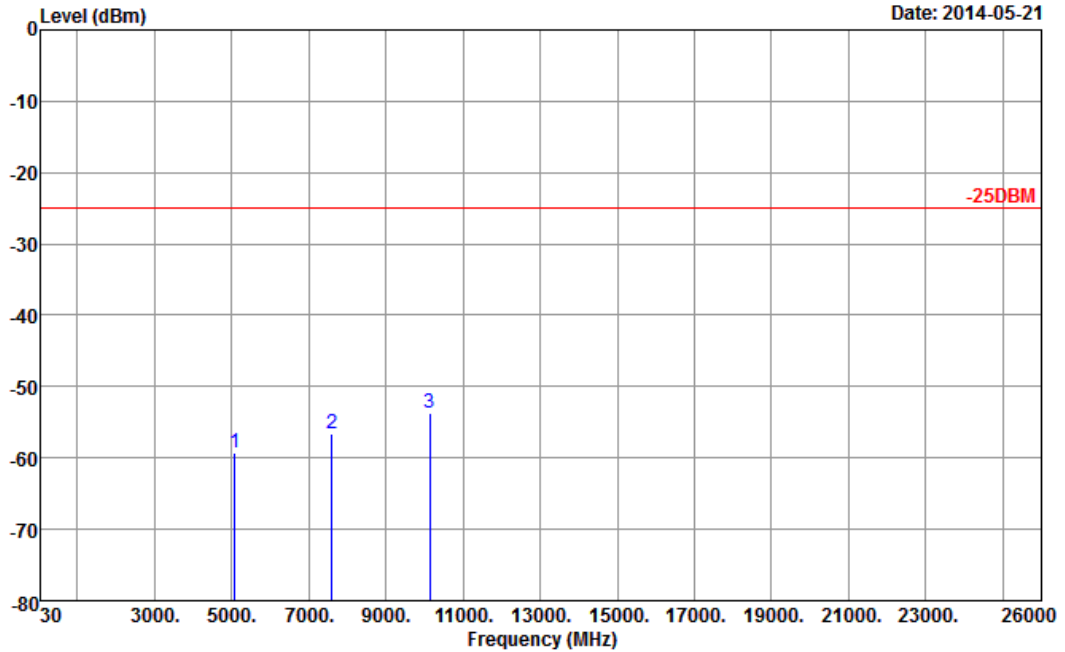

Site : 03CH01-SZ
 Condition : -25DBM HF_EIRP_H_130101 HORIZONTAL

Frequency (MHz)	EIRP (dBm)	Limit (dBm)	Over Limit (dB)	SPA Reading (dBm)	S.G. Power (dBm)	TX Cable loss (dB)	TX Antenna Gain (dBi)	Polarization (H/V)	Result
5070.00	-59.29	-25	-34.29	-70.23	-38.20	1.2	7.60	H	Pass
7605.00	-56.67	-25	-31.67	-75.48	-68.60	1.56	9.90	H	Pass
10140.00	-53.64	-25	-28.64	-77.16	-67.90	1.78	11.60	H	Pass



Band :	LTE Band 7	Temperature :	23~25°C
Test Mode :	20MHz QPSK RB Size 1 Offset 49	Relative Humidity :	48~52%
Test Engineer :	Kaer Huang	Polarization :	Vertical
Remark :	Spurious emissions within 30-10th harmonic were found more than 20dB below limit line.		

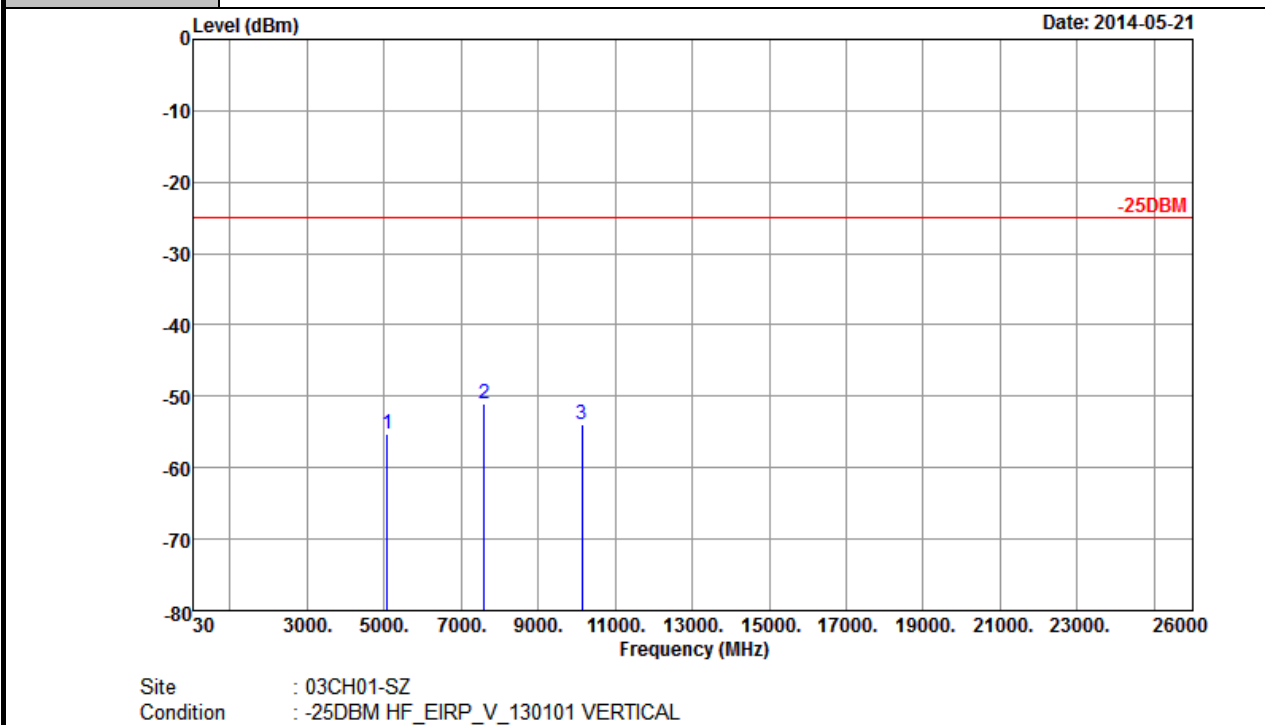

Frequency (MHz)	EIRP (dBm)	Limit (dBm)	Over Limit (dB)	SPA Reading (dBm)	S.G. Power (dBm)	TX Cable loss (dB)	TX Antenna Gain (dBi)	Polarization (H/V)	Result
5070	-55.27	-25.00	-30.27	-67.99	-43.20	1.2	7.60	V	Pass
7605	-50.93	-25.00	-25.93	-70.18	-70.30	1.56	9.90	V	Pass
10140	-53.96	-25.00	-28.96	-77.19	-64.60	1.78	11.60	V	Pass

3.8 Frequency Stability Measurement

3.8.1 Description of Frequency Stability Measurement

The frequency stability shall be measured by variation of ambient temperature and variation of primary supply voltage to ensure that the fundamental emission stays within the authorized frequency block. The frequency stability of the transmitter shall be maintained within $\pm 0.00025\%$ ($\pm 2.5\text{ppm}$) of the center frequency.

3.8.2 Measuring Instruments

The measuring equipment is listed in the section 4 of this test report.

3.8.3 Test Procedures for Temperature Variation

1. The EUT was set up in the thermal chamber and connected with the system simulator.
2. With power OFF, the temperature was decreased to -30°C and the EUT was stabilized before testing. Power was applied and the maximum change in frequency was recorded within one minute.
3. With power OFF, the temperature was raised in 10°C step up to 50°C . The EUT was stabilized at each step for at least half an hour. Power was applied and the maximum frequency change was recorded within one minute.

3.8.4 Test Procedures for Voltage Variation

1. The EUT was placed in a temperature chamber at $25\pm 5^{\circ}\text{C}$ and connected with the system simulator.
2. The power supply voltage to the EUT was varied from 85% to 115% of the nominal value measured at the input to the EUT.
3. The variation in frequency was measured for the worst case.

3.8.5 Test Setup

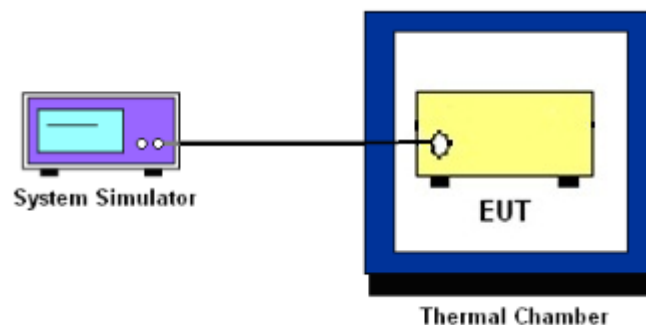

3.8.6 Test Result of Temperature Variation

Band :	LTE Band 4 (QPSK)	Limit (ppm) :	2.5
Temperature (°C)	BW 10MHz		Result
	Deviation (ppm)		
50	+0.0042		PASS
40	+0.0040		
30	+0.0036		
20	+0.0036		
10	+0.0044		
0	+0.0040		
-10	+0.0051		
-20	+0.0036		
-30	+0.0043		

Band :	LTE Band 7 (QPSK)	Limit (ppm) :	2.5
Temperature (°C)	BW 10MHz		Result
	Deviation (ppm)		
50	+0.0056		PASS
40	+0.0054		
30	+0.0043		
20	+0.0046		
10	+0.0049		
0	+0.0048		
-10	+0.0061		
-20	+0.0055		
-30	+0.0069		

3.8.7 Test Result of Voltage Variation

Band	Bandwidth	Voltage (Volt)	Deviation (ppm)	Limit (ppm)	Result
LTE Band 4	10M	4.2	+0.0046	2.5	PASS
		Normal	+0.0036		
		3.6	+0.0053		
LTE Band 7	10M	4.2	+0.0042	2.5	PASS
		Normal	+0.0056		
		3.6	+0.0054		

Remark:

1. Normal Voltage = 3.7V.
2. The manufacturer declared that the EUT could work properly between voltage 3.6V ~ 4.2V.



4 List of Measuring Equipment

Instrument	Manufacturer	Model No.	Serial No.	Characteristics	Calibration Date	Test Date	Due Date	Remark
Spectrum Analyzer	R&S	FSV40	101078	10Hz~40GHz	Jun. 17, 2013	Apr. 04, 2014~ Apr. 05, 2014	Jun. 16, 2014	Conducted (TH01-SZ)
Thermal Chamber	Hongzhan	LP-150U	HD20120425	-40°C~150°C	Feb. 21, 2014	Apr. 04, 2014~ Apr. 05, 2014	Feb. 20, 2015	Conducted (TH01-SZ)
ESCIO TEST Receiver	R&S	ESCI	100724	9kHz~3GHz	Feb. 21, 2014	May 21, 2014	Feb. 20, 2015	Radiation (03CH01-SZ)
Signal Analyzer	R&S	FSV40	101078	10Hz~40GHz	Jun. 17, 2013	May 21, 2014	Jun. 16, 2014	Radiation (03CH01-SZ)
Bilog Antenna	TESEQ	CBL 6112D	23188	30MHz~2GHz	Oct. 26, 2013	May 21, 2014	Oct. 25, 2014	Radiation (03CH01-SZ)
Double Ridge Horn Antenna	ETS Lindgren	3117	00119436	1GHz~18GHz	Oct. 26, 2013	May 21, 2014	Oct. 25, 2014	Radiation (03CH01-SZ)
Double Ridged Horn Antenna	COM-POWER	AH-840	101073	18GHz~40GHz	Jan. 27, 2014	May 21, 2014	Jan. 26, 2015	Radiation (03CH01-SZ)
Amplifier	ADVANTEST	BB525C	E9007003	9kHz~3000MHz	Feb. 21, 2014	May 21, 2014	Feb. 20, 2015	Radiation (03CH01-SZ)
Amplifier	Agilent	83017A	MY39501302	3Hz~26.5GHz	Mar. 03, 2014	May 21, 2014	Mar. 02, 2015	Radiation (03CH01-SZ)
AC Source(AVR)	Chroma	61601	616010001985	100Vac~250Vac	Mar. 25, 2014	May 21, 2014	Mar. 24, 2015	Radiation (03CH01-SZ)
Turn Table	EM Electronics	EM 1000	N/A	0~360 degree	NCR	May 21, 2014	NCR	Radiation (03CH01-SZ)
Antenna Mast	EM Electronics	EM 1000	N/A	1 m~4 m	NCR	May 21, 2014	NCR	Radiation (03CH01-SZ)
Spectrum Analyzer	R&S	FSP 7	100818	9kHz~7GHz	Sep. 03, 2013	May 21, 2014	Sep. 02, 2014	ERP/EIRP (OTA01-SZ)
Quad-Ridged Horn	ETS-Lindgren	3164-08	00102954	700MHz~10000MHz	N/A	May 21, 2014	N/A	ERP/EIRP (OTA01-SZ)
Multi-Devices Controller	ETS-Lindgren	2090-OPT1	00108147	N/A	N/A	May 21, 2014	N/A	ERP/EIRP (OTA01-SZ)
Switch Control Mainframe	Agilent	3499A	MY42005451	N/A	N/A	May 21, 2014	N/A	ERP/EIRP (OTA01-SZ)



5 Uncertainty of Evaluation

Uncertainty of Radiated Emission Measurement (30 MHz ~ 1000 MHz)

Measuring Uncertainty for a Level of Confidence of 95% ($U = 2Uc(y)$)	3.90
---	------