

FCC TEST REPORT (PART 24)

REPORT NO.: RF131024N040-2
MODEL NO.: HT853W
FCC ID: WVBAHT853W
RECEIVED: Oct. 24, 2013
TESTED: Oct. 25, 2013 ~ Nov. 07, 2013
ISSUED: Nov. 07, 2013

APPLICANT: Brightstar Corporation

ADDRESS: 9725 NW 117th Ave., Miami, Florida, United States

ISSUED BY: Bureau Veritas Shenzhen Co., Ltd.
Dongguan Branch

LAB ADDRESS: No. 34, Chenwulu Section, Guantai Road, Houjie
Town, Dongguan City, Guangdong 523942, China

TEST LOCATION: No. 34, Chenwulu Section, Guantai Road, Houjie
Town, Dongguan City, Guangdong 523942, China

This report should not be used by the client to claim
product certification, approval, or endorsement by A2LA
or any government agencies.

This report is for your exclusive use. Any copying or replication of this report to or for any other person or entity, or use of our name or trademark, is permitted only with our prior written permission. This report sets forth our findings solely with respect to the test samples identified herein. The results set forth in this report are not indicative or representative of the quality or characteristics of the lot from which a test sample was taken or any similar or identical product unless specifically and expressly noted. Our report includes all of the tests requested by you and the results thereof based upon the information that you provided to us. You have 60 days from date of issuance of this report to notify us of any material error or omission caused by our negligence, provided, however, that such notice shall be in writing and shall specifically address the issue you wish to raise. A failure to raise such issue within the prescribed time shall constitute your unqualified acceptance of the completeness of this report, the tests conducted and the correctness of the report contents. Unless specific mention, the uncertainty of measurement has been explicitly taken into account to declare the compliance or non-compliance to the specification.

TABLE OF CONTENTS

RELEASE CONTROL RECORD	4
1 CERTIFICATION	5
2 SUMMARY OF TEST RESULTS	6
2.1 MEASUREMENT UNCERTAINTY	6
3 GENERAL INFORMATION	8
3.1 GENERAL DESCRIPTION OF EUT	8
3.2 CONFIGURATION OF SYSTEM UNDER TEST	9
3.3 DESCRIPTION OF SUPPORT UNITS	9
3.4 TEST ITEM AND TEST CONFIGURATION	10
3.5 EUT OPERATING CONDITIONS	11
3.6 GENERAL DESCRIPTION OF APPLIED STANDARDS	11
4 TEST TYPES AND RESULTS	12
4.1 OUTPUT POWER MEASUREMENT	12
4.1.1 LIMITS OF OUTPUT POWER MEASUREMENT	12
4.1.2 TEST PROCEDURES	12
4.1.3 TEST SETUP	13
4.1.4 TEST RESULTS	14
4.2 FREQUENCY STABILITY MEASUREMENT	16
4.2.1 LIMITS OF FREQUENCY STABILITY MEASUREMENT	16
4.2.2 TEST PROCEDURE	16
4.2.3 TEST SETUP	16
4.2.4 TEST RESULTS	17
4.3 OCCUPIED BANDWIDTH MEASUREMENT	18
4.3.1 TEST PROCEDURES	18
4.3.2 TEST SETUP	18
4.4 BAND EDGE MEASUREMENT	21
4.4.1 LIMITS OF BAND EDGE MEASUREMENT	21
4.4.2 TEST SETUP	21
4.4.3 TEST PROCEDURES	21
4.4.4 TEST RESULTS	22
4.5 CONDUCTED SPURIOUS EMISSIONS	23
4.5.1 LIMITS OF CONDUCTED SPURIOUS EMISSIONS MEASUREMENT	23
4.5.2 TEST PROCEDURE	23
4.5.3 TEST SETUP	23
4.6 RADIATED EMISSION MEASUREMENT	27
4.6.1 LIMITS OF RADIATED EMISSION MEASUREMENT	27
4.6.2 TEST PROCEDURES	27
4.6.3 DEVIATION FROM TEST STANDARD	27
4.6.4 TEST SETUP	28
4.6.5 TEST RESULTS	29
4.7 PEAK TO AVERAGE RATIO	31
4.7.1 LIMITS OF PEAK TO AVERAGE RATIO MEASUREMENT	31
4.7.2 TEST SETUP	31
4.7.3 TEST PROCEDURES	31
4.7.4 TEST RESULTS	32



5	PHOTOGRAPHS OF THE TEST CONFIGURATION.....	35
6	INFORMATION ON THE TESTING LABORATORIES.....	36
7	APPENDIX A – MODIFICATIONS RECORDERS FOR ENGINEERING CHANGES TO THE EUT BY THE LAB.....	37



BUREAU
VERITAS

Test Report No.: RF131024N040-2

RELEASE CONTROL RECORD

ISSUE NO.	REASON FOR CHANGE	DATE ISSUED
RF131024N040-2	Original release	Nov. 07, 2013



1 CERTIFICATION

PRODUCT: Fixed Wireless Terminal Router 3G

MODEL: HT853W

BRAND: AVVIO

APPLICANT: Brightstar Corporation

TESTED: Oct. 25, 2013 ~ Nov. 07, 2013

TEST SAMPLE: Production Unit

STANDARDS: **FCC Part 24, Subpart E**

The above equipment (model: HT853W) has been tested by **Bureau Veritas Shenzhen Co., Ltd. Dongguan Branch**, and found compliance with the requirement of the above standards. The test record, data evaluation & Equipment Under Test (EUT) configurations represented herein are true and accurate accounts of the measurements of the sample's EMC characteristics under the conditions specified in this report.

TESTED BY :  , **DATE** : Nov. 07, 2013
Glyn He/ Project Engineer

APPROVED BY :  , **DATE** : Nov. 07, 2013
Sam Tung / Technical Manager



2 SUMMARY OF TEST RESULTS

The EUT has been tested according to the following specifications:

APPLIED STANDARD: FCC Part 24 & Part 2			
STANDARD SECTION	TEST TYPE	RESULT	REMARK
2.1046 24.232	Equivalent Isotropic Radiated Power	PASS	Meet the requirement of limit.
2.1055 24.235	Frequency Stability	PASS	Meet the requirement of limit.
2.1049 24.238(b)	Occupied Bandwidth	PASS	Meet the requirement of limit.
24.238(b)	Band Edge Measurements	PASS	Meet the requirement of limit.
2.1051 24.238	Conducted Spurious Emissions	PASS	Meet the requirement of limit.
2.1053 24.238	Radiated Spurious Emissions	PASS	Meet the requirement of limit.

2.1 MEASUREMENT UNCERTAINTY

Where relevant, the following measurement uncertainty levels have been estimated for tests performed on the EUT as specified in CISPR 16-4-2:

MEASUREMENT	FREQUENCY	UNCERTAINTY
Conducted emissions	9kHz~30MHz	2.67dB
Radiated emissions	30MHz ~ 1GHz	4.81dB
	1GHz ~ 18GHz	4.3dB
	18GHz ~ 40GHz	1.94dB

This uncertainty represents an expanded uncertainty expressed at approximately the 95% confidence level using a coverage factor of k=2.



2.2 TEST SITE AND INSTRUMENTS

Equipment	Manufacturer	Model No.	Serial No.	Last Cal.	Next Cal.
Spectrum Analyzer	Agilent	E4446A	MY46180622	Apr. 24,13	Apr. 23,14
EMI Test Receiver	Rohde&Schwarz	ESVD	847398/003	May 14,13	May 13,14
Bilog Antenna (25MHz-2GHz)	Teseq	CBL 6111D	27089	Nov. 22,12	Nov. 21,13
Horn Antenna (1GHz -18GHz)	EMCO	3117	00062558	Oct.18, 13	Oct.17,14
Pre-Amplifier (20MHz-3GHz)	EMCI	EMC 330	980095	Nov. 02,13	Nov. 01,14
Pre-Amplifier (100MHz-26.5GHz)	Agilent	8449B	3008A00409	May 14,13	May 13,14
10m Semi-anechoic Chamber	CHANGLING	21.4m*12.1m*8 .8m	NSEMC006	Mar. 24,13	Mar. 23,14
Digital Multimeter	FLUKE	15B	A1220010D G	Oct. 31,13	Oct. 30,14
Horn Antenna (15GHz-40GHz)	SCHWARZBECK	BBHA 9170	BBHA91702 42	Jan. 04,12	Jan. 03,14
Pre-Amplifier (18GHz-40GHz)	EMCI	EMC 184045	980102	Nov. 04,13	Nov. 03,14
Universal Radio Communication Tester	Rohde&Schwarz	CMU 200	123259	Apr. 16,12	Apr. 15,14
Test Software	ADT	ADT_Radiated V7.6.15	N/A	N/A	N/A

- NOTE:**
1. The calibration interval of the above test instruments is 12 months and the calibrations are traceable to CEPREI/CHINA, GRGT/CHINA and NIM/CHINA.
 2. The test was performed in Dongguan Chamber 10m.
 3. The horn antenna are used only for the measurement of emission frequency above 1GHz if tested.
 4. The FCC Site Registration No. is 502831.



3 GENERAL INFORMATION

3.1 GENERAL DESCRIPTION OF EUT

PRODUCT	Fixed Wireless Terminal Router 3G
MODEL NO.	HT853W
FCC ID	WVBAHT853W
HW Version	V2.0
SW Version	W200_AVVIO_T2
POWER SUPPLY	DC 12V from adapter
MODULATION TYPE	GSM, GPRS: GMSK EDGE: 8PSK WCDMA : BPSK
FREQUENCY RANGE	GSM, GPRS, EDGE: 1850.2MHz ~ 1909.8MHz WCDMA: 1852.4MHz ~ 1907.6MHz
MAX. EIRP POWER	GSM: 0.89Watts EDGE: 0.42Watts WCDMA: 0.27Watts
POWER CLASS	4
ANTENNA TYPE	Fix external antenna (Monopole) with 3dBi gain
I/O PORTS	Refer to user's manual
CABLE SUPPLIED	RJ45 cable:Unshielded,Detachable,1.6m RJ11 cable: Unshielded,Detachable,1.5m
ACCESSORY DEVICES	Refer to note as below

NOTE:

1. WLAN, GSM, WCDMA technologies are used for the EUT.
2. The EUT's accessories list refers to EUT Photo. pdf. The EUT was powered by the following adapter:

ADAPTER	
BRAND:	powertek
MODEL:	SWPP-12001000-US
INPUT:	AC 100-240V, 50/60Hz,1000mA
OUTPUT:	DC 12V, 1000mA
DC LINE:	Unshielded, Undetachable, 1.5M,with one core

3. The above EUT information was declared by manufacturer and for more detailed features description, please refer to the manufacturer's specifications or user's manual.



3.2 CONFIGURATION OF SYSTEM UNDER TEST

Please see section 5 photographs of the test configuration for reference.

3.3 DESCRIPTION OF SUPPORT UNITS

The EUT has been tested as an independent unit together with other necessary accessories or support units. The following support units or accessories were used to form a representative test configuration during the tests.

NO.	PRODUCT	BRAND	MODEL NO.	SERIAL NO.	FCC ID
1	Notebook	DELL	5P2PM2X	12400120329	N/A
2	Mouse	DELL	M056UOA	01688082	N/A

NO.	SIGNAL CABLE DESCRIPTION OF THE ABOVE SUPPORT UNITS
1.	AC Line :Unshielded, Detachable,1.5m;DC Line: Unshielded, Undetachable,1.8m; HDMI Cable: Shielded, Detachable,1.6m, with a core
2	USB Line: Unshielded, undetachable, 1.5m.



3.4 TEST ITEM AND TEST CONFIGURATION

Pre-Scan has been conducted to determine the worst-case mode from all possible combinations between available modulations, data rates, XYZ axis and antenna ports

The worst case was found when positioned on Y-plane for EIRP and X-axis for radiated emission. Following channel(s) was (were) selected for the final test as listed below:

EUT CONFIGURE MODE	DESCRIPTION
A	GSM link

GSM MODE

EUT CONFIGURE MODE	TEST ITEM	AVAILABLE CHANNEL	TESTED CHANNEL	MODE
A	EIRP	512 to 810	512, 661, 810	GSM, EDGE
A	FREQUENCY STABILITY	512 to 810	661	GSM, EDGE
A	OCCUPIED BANDWIDTH	512 to 810	512, 661, 810	GSM, EDGE
A	BAND EDGE	512 to 810	512, 810	GSM, EDGE
A	CONDCUDETED EMISSION	512 to 810	512, 661, 810	GSM, EDGE
A	RADIATED EMISSION	512 to 810	661	GSM, EDGE

WCDMA MODE

EUT CONFIGURE MODE	TEST ITEM	AVAILABLE CHANNEL	TESTED CHANNEL	MODE
A	EIRP	9262 to 9538	9262, 9400, 9538	WCDMA
A	FREQUENCY STABILITY	9262 to 9538	9400	WCDMA
A	OCCUPIED BANDWIDTH	9262 to 9538	9262, 9400, 9538	WCDMA, HSDPA, HSUPA
A	BAND EDGE	9262 to 9538	9262, 9538	WCDMA, HSDPA, HSUPA
A	CONDCUDETED EMISSION	9262 to 9538	9262, 9400, 9538	WCDMA
A	RADIATED EMISSION	9262 to 9538	9400	WCDMA



TEST CONDITION:

TEST ITEM	ENVIRONMENTAL CONDITIONS	INPUT POWER	TESTED BY
EIRP	23deg. C, 59%RH	12Vdc from adapter	Venless Long
FREQUENCY STABILITY	23deg. C, 59%RH	12Vdc from adapter	Venless Long
OCCUPIED BANDWIDTH	23deg. C, 59%RH	12Vdc from adapter	Venless Long
BAND EDGE	23deg. C, 59%RH	12Vdc from adapter	Venless Long
CONDCUDED EMISSION	23deg. C, 59%RH	12Vdc from adapter	Venless Long
RADIATED EMISSION	25deg. C, 61%RH	12Vdc from adapter	Venless Long

3.5 EUT OPERATING CONDITIONS

The EUT makes a call to the communication simulator. The communication simulator station system controlled a EUT to export maximum output power under transmission mode and specific channel frequency

3.6 GENERAL DESCRIPTION OF APPLIED STANDARDS

The EUT is a RF product. According to the specifications of the manufacturer, it must comply with the requirements of the following standards:

FCC 47 CFR Part 2

FCC 47 CFR Part 24

ANSI/TIA/EIA-603-C 2004

NOTE: All test items have been performed and recorded as per the above standards.



4 TEST TYPES AND RESULTS

4.1 OUTPUT POWER MEASUREMENT

4.1.1 LIMITS OF OUTPUT POWER MEASUREMENT

Mobile and portable stations are limited to 2 watts EIRP

4.1.2 TEST PROCEDURES

EIRP MEASUREMENT:

- a. All measurements were done at low, middle and high operational frequency range. RBW and VBW is 1MHz for GSM, GPRS & EDGE and 5MHz for WCDMA mode.
- b. Substitution method is used for E.I.R.P measurement. In the semi-anechoic chamber, EUT placed on the 0.8m height of Turn Table, rotated the table around 360 degrees to search the maximum radiation power and receiver antenna shall be rotated vertical and horizontal polarization and moved height from 1m to 4m to find the maximum polar radiated power. The “Read Value” is the spectrum reading the maximum power value.
- c. The substitution horn antenna is substituted for EUT at the same position and signals generator export the CW signal to the substitution antenna via a tx cable. Rotated the Turn Table and moved receiving antenna to find the maximum radiation power. Adjust output power level of S.G to get a Value of spectrum reading equal to “Read Value “ of step b. Record the power level of S.G
- d. $EIRP = \text{Output power level of S.G} - \text{TX cable loss} + \text{Antenna gain of substitution horn.}$

CONDUCTED POWER MEASUREMENT:

The EUT was set up for the maximum power with GSM, GPRS, EDGE & WCDMA link data modulation and link up with simulator. Set the EUT to transmit under low, middle and high channel and record the power level shown on simulator.



4.1.3 TEST SETUP

EIRP MEASUREMENT:

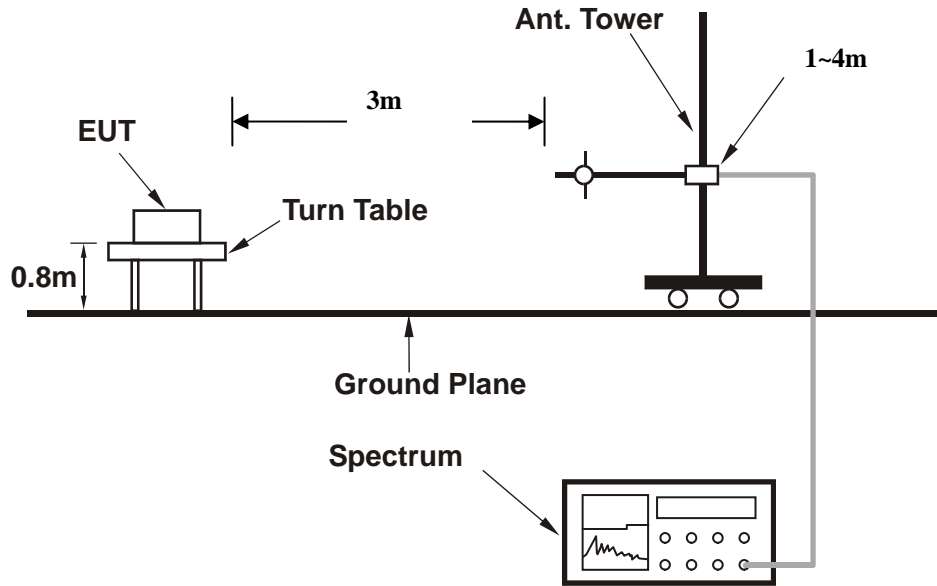

For the actual test configuration, please refer to the attached file (Test Setup Photo).

CONDUCTED POWER MEASUREMENT:

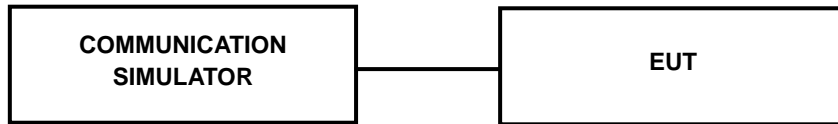

For the actual test configuration, please refer to the attached file (Test Setup Photo).



4.1.4 TEST RESULTS

CONDUCTED OUTPUT POWER (dBm)

Band	GSM1900		
Channel	512	661	810
Frequency (MHz)	1850.2	1880.0	1909.8
GSM	28.37	28.24	28.25
GPRS 8	28.35	28.20	28.22
GPRS 10	26.35	26.23	26.27
GPRS 11	24.48	24.38	24.40
GPRS 12	22.96	22.81	22.80
EDGE 8 (MCS1)	28.36	28.25	28.26
EDGE 10 (MCS1)	26.33	26.23	26.25
EDGE 11 (MCS1)	24.50	24.38	24.40
EDGE 12 (MCS1)	22.95	22.88	22.90
EDGE 8 (MCS9)	25.47	25.33	25.34
EDGE 10 (MCS9)	22.95	22.83	22.87
EDGE 11 (MCS9)	21.00	20.91	20.95
EDGE 12 (MCS9)	19.98	19.86	19.90

Band	WCDMA II		
Channel	9262	9400	9538
Frequency (MHz)	1852.4	1880.0	1907.6
RMC 12.2K	21.42	21.54	20.94
HSDPA Subtest-1	19.90	19.89	19.56
HSDPA Subtest-2	19.87	19.90	19.56
HSDPA Subtest-3	20.89	20.87	20.51
HSDPA Subtest-4	19.99	19.88	19.59
HSUPA Subtest-1	20.97	21.11	20.86
HSUPA Subtest-2	19.49	19.61	19.45
HSUPA Subtest-3	20.17	20.24	19.90
HSUPA Subtest-4	19.94	19.99	19.62
HSUPA Subtest-5	21.41	21.33	21.01



EIRP POWER (dBm)

GSM 1900_Class8 (Horizontal)					
CHANNEL NO.	FREQUENCY (MHz)	SPA Reading (dBm)	CORRECTION FACTOR (dB)	EIRP POWER	
				dBm	Watt
512	1850.2	-21.54	44.32	22.78	0.19
661	1880	-22.14	44.37	22.23	0.17
810	1909.2	-22.64	43.28	20.64	0.12
GSM 1900_Class8 (Vertical)					
CHANNEL NO.	FREQUENCY (MHz)	SPA Reading (dBm)	CORRECTION FACTOR (dB)	EIRP POWER	
				dBm	Watt
512	1850.2	-16.67	46.18	29.51	0.89
661	1880	-16.52	45.72	29.20	0.83
810	1909.2	-16.13	45.21	29.08	0.81

EDGE 1900 (1 Uplink) (Horizontal)					
CHANNEL NO.	FREQUENCY (MHz)	SPA Reading (dBm)	CORRECTION FACTOR (dB)	EIRP POWER	
				dBm	Watt
512	1850.2	-24.65	44.32	19.67	0.09
661	1880.0	-24.25	44.37	20.12	0.10
810	1909.2	-23.87	43.28	19.41	0.09
EDGE 1900 (1 Uplink) (Vertical)					
CHANNEL NO.	FREQUENCY (MHz)	SPA Reading (dBm)	CORRECTION FACTOR (dB)	EIRP POWER	
				dBm	Watt
512	1850.2	-20.14	46.18	26.04	0.40
661	1880.0	-19.45	45.72	26.27	0.42
810	1909.2	-19.18	45.21	26.03	0.40

WCDMA Band II_RMC 12.2K (Horizontal)					
CHANNEL NO.	FREQUENCY (MHz)	SPA Reading (dBm)	CORRECTION FACTOR (dB)	EIRP POWER	
				dBm	Watt
9262	1852.4	-25.68	43.99	18.31	0.07
9400	1880	-25.98	44.37	18.39	0.07
9538	1907.6	-26.13	43.4	17.27	0.05
WCDMA Band II_RMC 12.2K (Vertical)					
CHANNEL NO.	FREQUENCY (MHz)	SPA Reading (dBm)	CORRECTION FACTOR (dB)	EIRP POWER	
				dBm	Watt
9262	1852.4	-22.05	46.33	24.28	0.27
9400	1880	-22.36	45.88	23.52	0.22
9538	1907.6	-22.57	45.06	22.49	0.18

REMARKS: 1. EIRP Output Power (dBm) = SPA Reading (dBm) + Correction Factor (dB).
 2. Correction factor (dB) = Free Space Loss + Antenna Factor + Cable Loss



4.2 FREQUENCY STABILITY MEASUREMENT

4.2.1 LIMITS OF FREQUENCY STABILITY MEASUREMENT

The frequency stability shall be sufficient to ensure that the fundamental emission stays within the authorized frequency block.

4.2.2 TEST PROCEDURE

- Device is placed at the oven room. The oven room could control the temperatures and humidity. Power warm up is at least 15 min and power applied should perform before recording frequency error.
- EUT is connected the external power supply to control the DC input power. The test voltage range is from minimum to maximum working voltage. Each step shall be record the frequency error rate.
- The temperature range step is 10 degrees in this test items. All temperature levels shall be hold the $\pm 0.5^{\circ}\text{C}$ during the measurement testing. The each temperature step shall be at least 0.5 hours, consider the EUT could be test under the stability condition.

NOTE: The frequency error was recorded frequency error from the communication simulator.

4.2.3 TEST SETUP

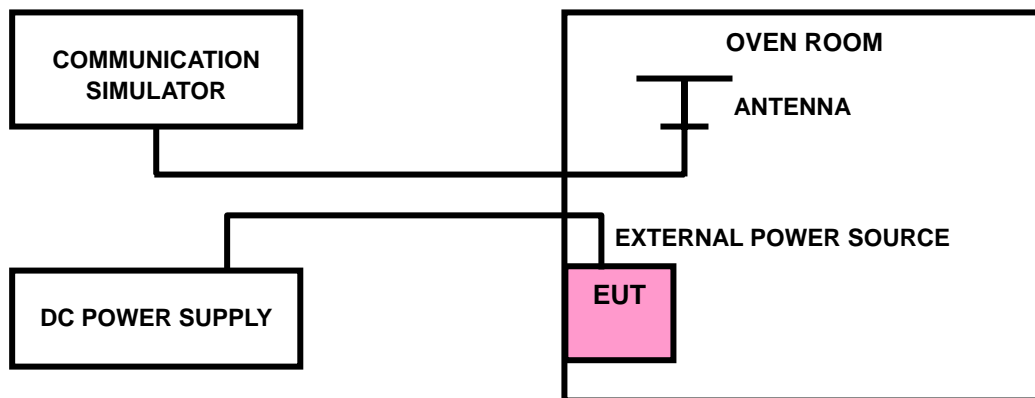



4.2.4 TEST RESULTS

FREQUENCY ERROR VS. VOLTAGE

VOLTAGE (Volts)	FREQUENCY ERROR (ppm)			LIMIT (ppm)
	GSM	EDGE	WCDMA	
13.2	0.0083	0.0078	0.01	2.5
12	0.0065	0.0062	0.01	2.5
10.9	0.0071	0.0066	0.01	2.5

NOTE: The applicant defined the normal working voltage of the battery is from 10.9Vdc to 13.2Vdc.

FREQUENCY ERROR vs. TEMPERATURE.

TEMP. (°C)	FREQUENCY ERROR (PPM)			LIMIT (PPM)
	GSM	EDGE	WCDMA	
-10	0.0023	0.0034	0.0013	2.5
0	0.0007	0.0019	0.0022	2.5
10	0.0016	0.0024	0.0034	2.5
20	0.0034	0.0034	0.0041	2.5
30	0.0040	0.0054	0.0051	2.5
40	0.0055	0.0060	0.0060	2.5
50	0.0071	0.0067	0.0076	2.5



4.3 OCCUPIED BANDWIDTH MEASUREMENT

4.3.1 TEST PROCEDURES

The EUT makes a call to the communication simulator. All measurements were done at low, middle and high operational frequency range. The communication simulator station system controlled a EUT to export maximum output power under transmission mode and specific channel frequency. Use OBW measurement function of Spectrum analyzer to measure 99 % occupied bandwidth.

4.3.2 TEST SETUP

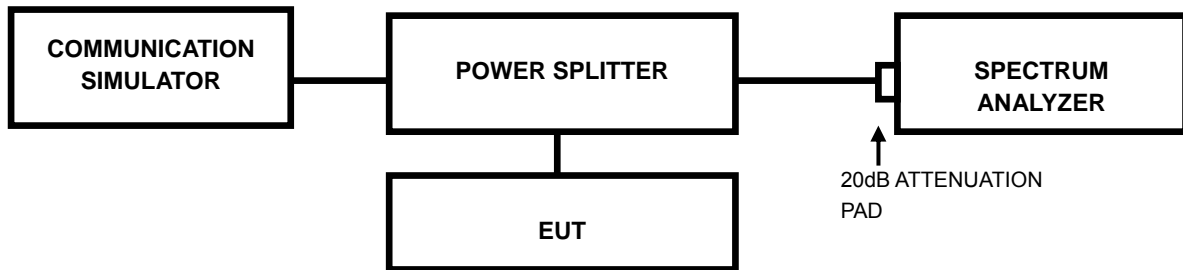



4.3.3 TEST RESULTS

CHANNEL	FREQUENCY (MHz)	99% OCCUPIED BANDWIDTH (kHz)		CHANNEL	FREQUENCY (MHz)	99% OCCUPIED BANDWIDTH (kHz)
		GSM	EDGE			WCDMA
512	1850.2	246.38	244.93	9262	1852.4	4190
661	1880.0	244.93	246.38	9400	1880.0	4170
810	1909.8	247.83	246.38	9538	1907.6	4190

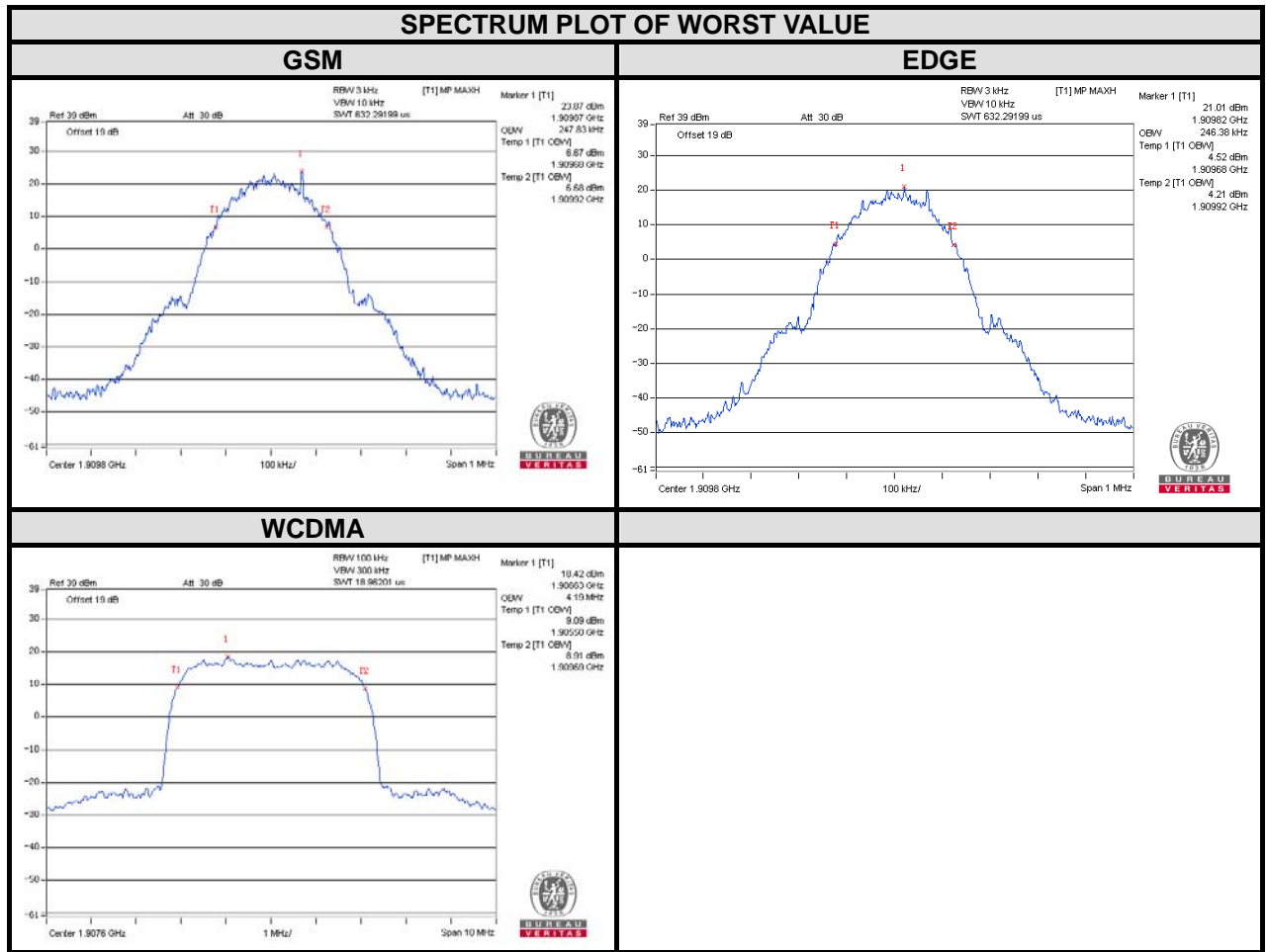



**BUREAU
VERITAS**

Test Report No.: RF131024N040-2

CHANNEL	FREQUENCY (MHz)	26dB BANDWIDTH (kHz)		CHANNEL	FREQUENCY (MHz)	26dB BANDWIDTH (kHz)
		GSM	EDGE			WCDMA
512	1850.2	311.6	314.2	9262	1852.4	4725
661	1880.0	313.9	309.8	9400	1880.0	4686
810	1909.8	312.8	313.1	9538	1907.6	4692

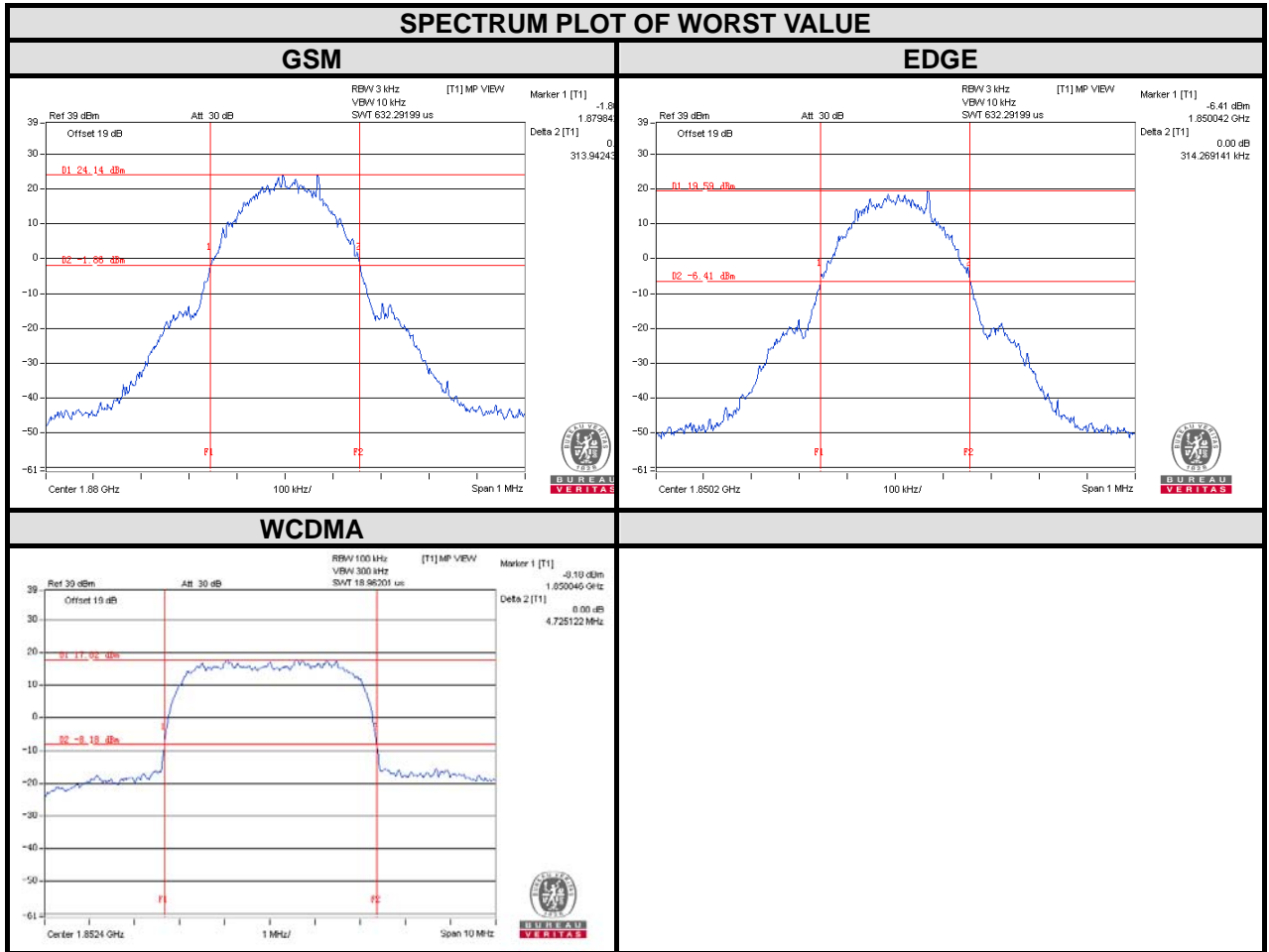



4.4 BAND EDGE MEASUREMENT

4.4.1 LIMITS OF BAND EDGE MEASUREMENT

Power of any emission outside of the authorized operating frequency ranges must be attenuated below the transmitting power (P) by a factor of at least $43 + 10 \log(P)$ dB. In the 1 MHz bands immediately outside and adjacent to the frequency block a resolution bandwidth of at least one percent of the emission bandwidth of the fundamental emission of the transmitter may be employed.

4.4.2 TEST SETUP

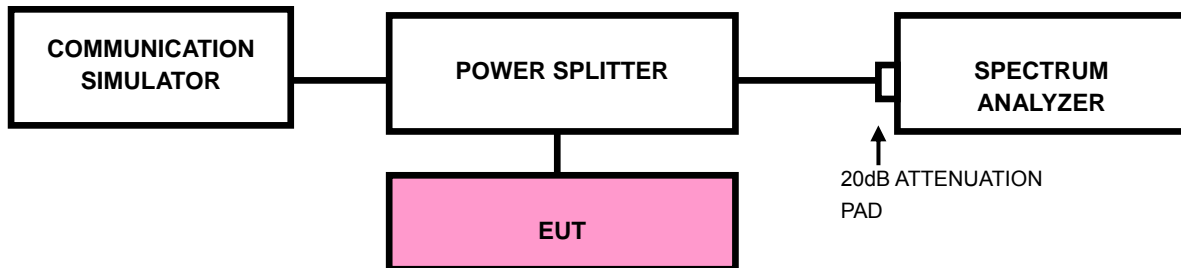

4.4.3 TEST PROCEDURES

- All measurements were done at low and high operational frequency range.
- The center frequency of spectrum is the band edge frequency and span is 1.5 MHz. RB of the spectrum is 3kHz and VB of the spectrum is 10kHz (GSM/GPRS/ EDGE).
- The center frequency of spectrum is the band edge frequency and span is 10MHz. RB of the spectrum is 100kHz and VB of the spectrum is 300kHz (WCDMA).
- Record the max trace plot into the test report.



4.4.4. TEST RESULTS

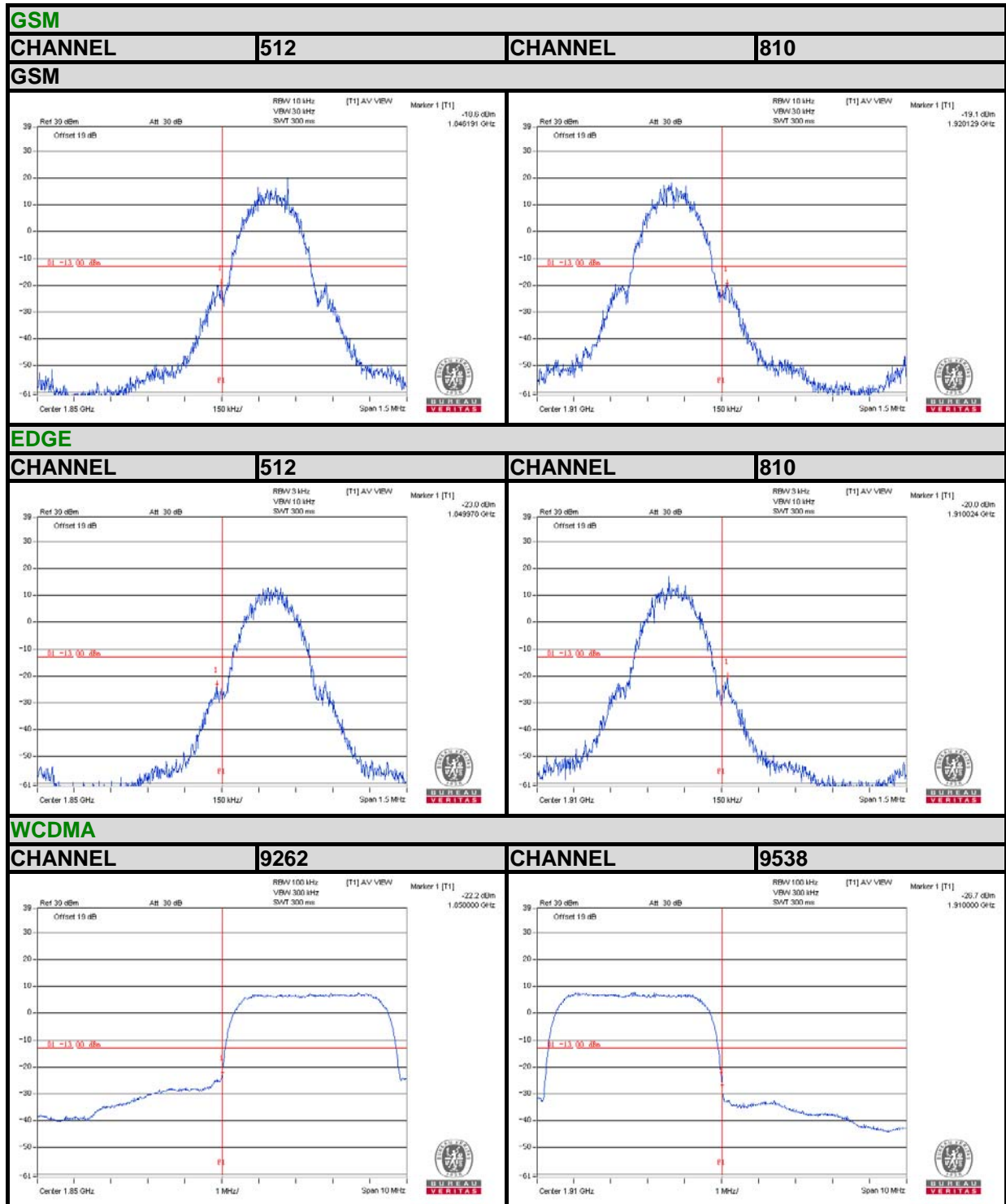

4.5 CONDUCTED SPURIOUS EMISSIONS

4.5.1 LIMITS OF CONDUCTED SPURIOUS EMISSIONS MEASUREMENT

The power of any emission outside of the authorized operating frequency ranges must be attenuated below the transmitting power (P) by a factor of at least $43 + 10 \log(P)$ dB. The emission limit equal to -13dBm .

4.5.2 TEST PROCEDURE

- a. The EUT makes a phone call to the communication simulator. All measurements were done at low, middle and high operational frequency range.
- b. Measuring frequency range is from 9 kHz to 19.1GHz. 20dB attenuation pad is connected with spectrum. RBW=1MHz and VBW=3MHz is used for conducted emission measurement.

4.5.3 TEST SETUP

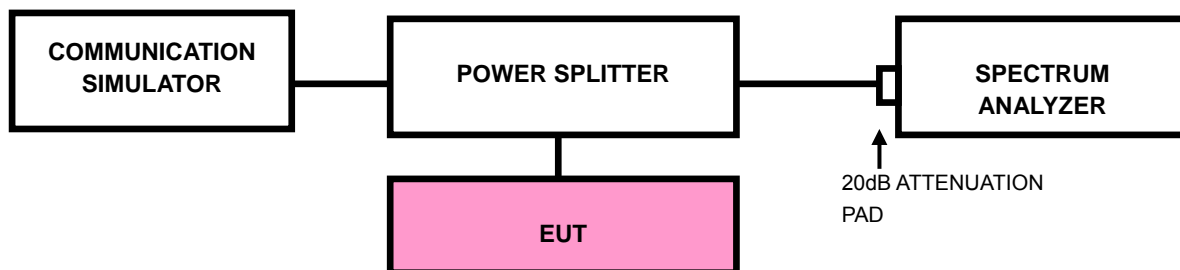



4.5.4 TEST RESULTS

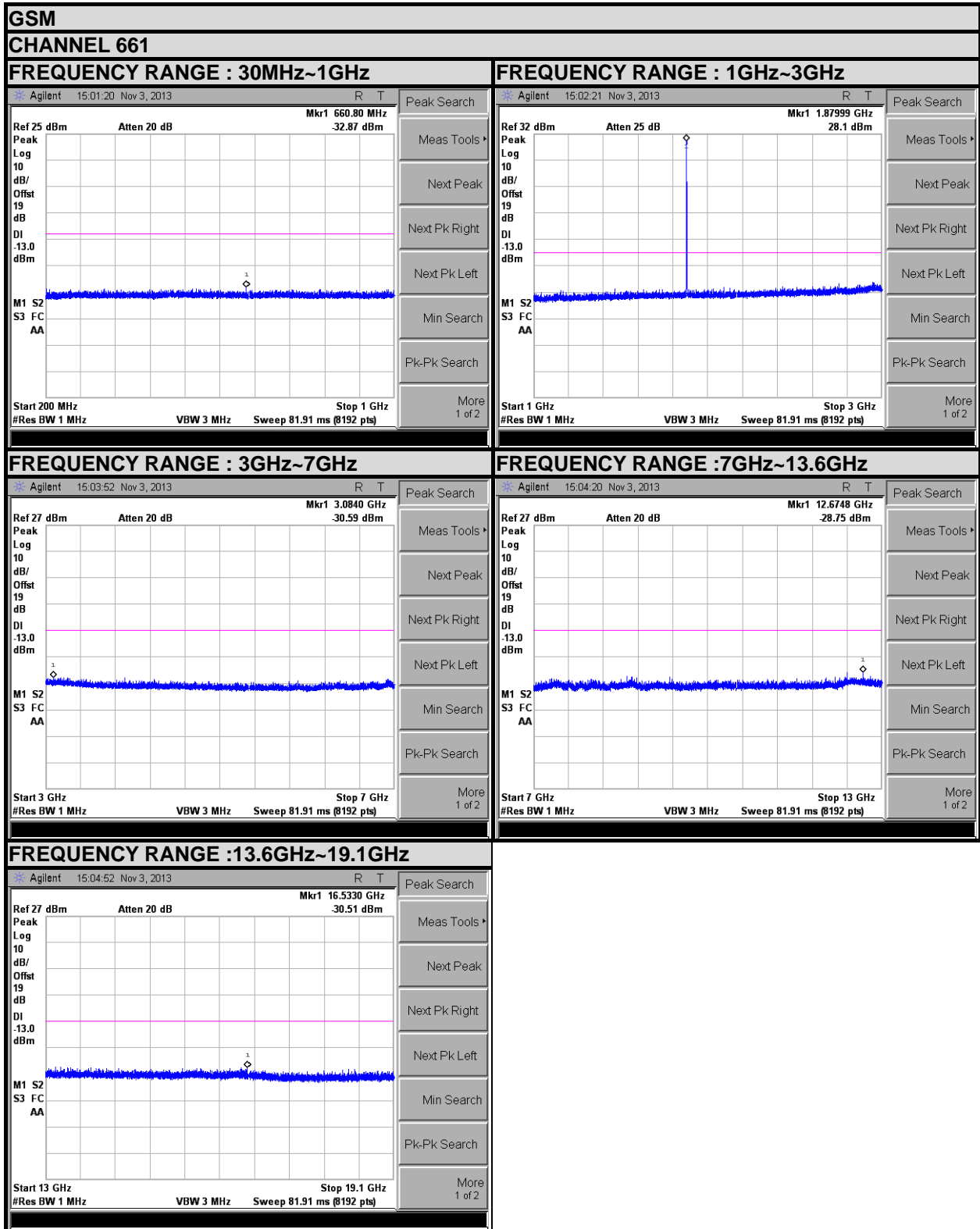



BUREAU VERITAS

Test Report No.: RF131024N040-2

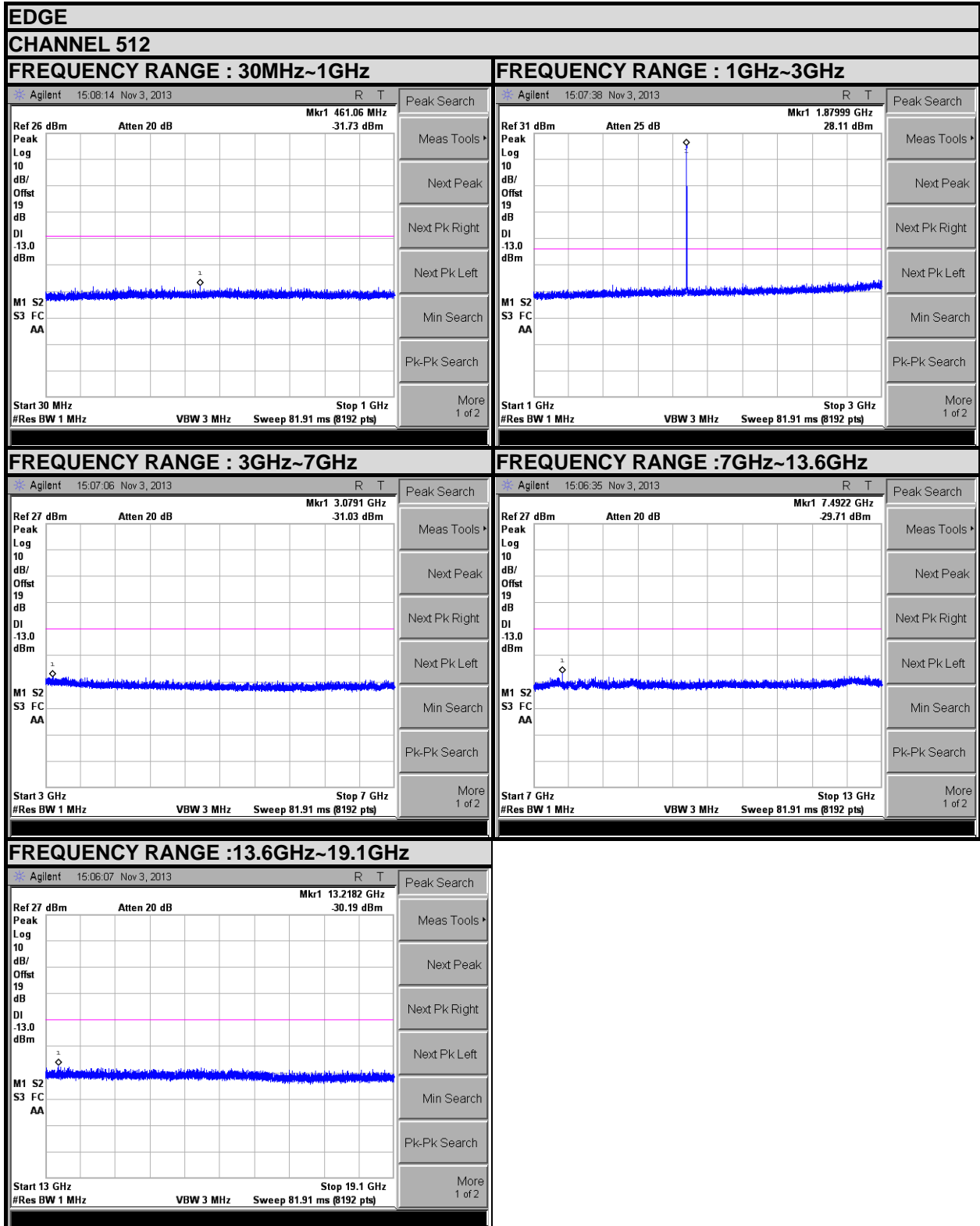

Bureau Veritas Shenzhen Co., Ltd.
Dongguan Branch

No. 34, Chenwulu Section, Guantai Rd.,
Houjie Town, Dongguan City,
Guangdong 523942, China

Tel: +86 769 8593 5656
Fax: +86 769 8593 1080
Email: customerservice.dg@cn.bureauveritas.com



BUREAU VERITAS

Test Report No.: RF131024N040-2

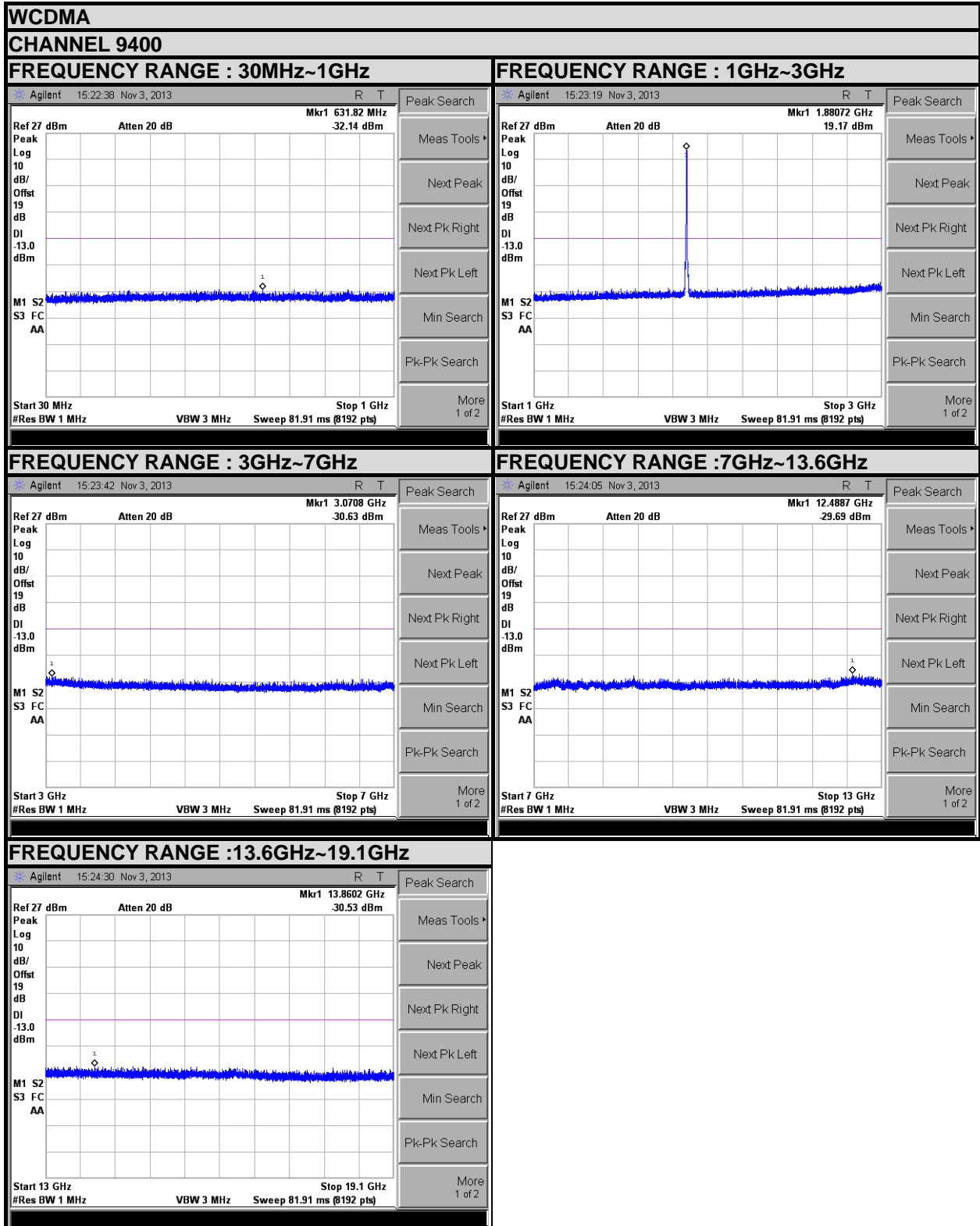

Bureau Veritas Shenzhen Co., Ltd.
Dongguan Branch

No. 34, Chenwulu Section, Guantai Rd.,
Houjie Town, Dongguan City,
Guangdong 523942, China

Tel: +86 769 8593 5656
Fax: +86 769 8593 1080
Email: customerservice.dg@cn.bureauveritas.com

4.6 RADIATED EMISSION MEASUREMENT

4.6.1 LIMITS OF RADIATED EMISSION MEASUREMENT

The power of any emission outside of the authorized operating frequency ranges must be attenuated below the transmitting power (P) by a factor of at least $43 + 10 \log(P)$ dB. The emission limit equal to -13dBm .

4.6.2 TEST PROCEDURES

- a. Substitution method is used for E.I.R.P measurement. In the semi-anechoic chamber, EUT placed on the 0.8m height of Turn Table, rotated the table around 360 degrees to search the maximum radiation power and receiver antenna shall be rotated vertical and horizontal polarization and moved height from 1m to 4m to find the maximum polar radiated power. The “Read Value” is the spectrum reading the maximum power value.
- b. The substitution horn antenna is substituted for EUT at the same position and signals generator export the CW signal to the substitution antenna via a TX cable. Rotated the Turn Table and moved receiving antenna to find the maximum radiation power. Adjust output power level of S.G to get a Value of spectrum reading equal to “Read Value “ of step a. Record the power level of S.G
- c. $\text{EIRP} = \text{Output power level of S.G} - \text{TX cable loss} + \text{Antenna gain of substitution horn.}$

NOTE: The resolution bandwidth and video bandwidth of test receiver/spectrum analyzer is 1MHz/3MHz.

4.6.3 DEVIATION FROM TEST STANDARD

No deviation



4.6.4 TEST SETUP

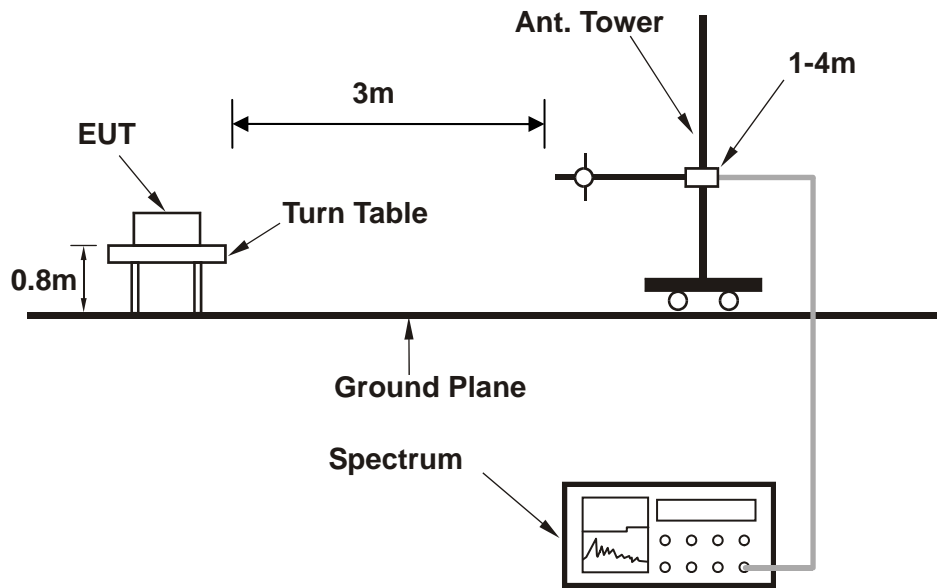

For the actual test configuration, please refer to the attached file (Test Setup Photo).



4.6.5 TEST RESULTS

GSM:

ANTENNA POLARITY & TEST DISTANCE: HORIZONTAL AT 3 M						
No.	Freq. (MHz)	SPA READING (dBm)	Limit (dBm)	S.G Power Value (dBm)	Correction Factor (dB)	EIRP (dBm)
1	3760	-57.6	-13	-45.24	4.07	-41.17
2	5640	-56.88	-13	-40.19	4.81	-35.38
3	7520	-59.4	-13	-40.94	5.48	-35.46
ANTENNA POLARITY & TEST DISTANCE: VERTICAL AT 3 M						
No.	Freq. (MHz)	SPA READING (dBm)	Limit (dBm)	S.G Power Value (dBm)	Correction Factor (dB)	EIRP (dBm)
1	3760	-56.8	-13	-43.79	4.07	-39.72
2	5640	-57.5	-13	-42.49	4.81	-37.68
3	7520	-58.6	-13	-40.24	5.48	-34.76

REMARKS:

1. EIRP(dBm) = S.G Power Value (dBm) + Correction Factor (dB).
2. Correction Factor (dB) = Substitution Antenna Gain (dB) + Cable Loss (dB)

EDGE:

ANTENNA POLARITY & TEST DISTANCE: HORIZONTAL AT 3 M						
No.	Freq. (MHz)	Emission Level (dBuV)	Limit (dBm)	S.G Power Value (dBm)	Correction Factor (dB)	EIRP (dBm)
1	3760	-53.4	-13	-40.99	4.07	-36.92
2	5640	-52.4	-13	-35.63	4.81	-30.82
3	7520	-55.7	-13	-37.03	5.48	-31.55
ANTENNA POLARITY & TEST DISTANCE: VERTICAL AT 3 M						
No.	Freq. (MHz)	Emission Level (dBuV)	Limit (dBm)	S.G Power Value (dBm)	Correction Factor (dB)	EIRP (dBm)
1	3760	-52.82	-13	-39.72	4.07	-35.65
2	5640	-54.78	-13	-39.60	4.81	-34.79
3	7520	-55.73	-13	-37.28	5.48	-31.80

REMARKS:

1. EIRP (dBm) = S.G Value (dBm) + Correction Factor (dB).
2. Correction Factor (dB) = Substitution Antenna Gain (dB) + Cable Loss (dB)



WCDMA:

ANTENNA POLARITY & TEST DISTANCE: HORIZONTAL AT 3 M						
No.	Freq. (MHz)	SPA READING (dBm)	Limit (dBm)	S.G Power Value (dBm)	Correction Factor (dB)	EIRP (dBm)
1	3760	-53.78	-13	-41.38	4.07	-37.31
2	5640	-52.44	-13	-35.67	4.81	-30.86
3	7520	-55.89	-13	-37.23	5.48	-31.75
ANTENNA POLARITY & TEST DISTANCE: VERTICAL AT 3 M						
No.	Freq. (MHz)	SPA READING (dBm)	Limit (dBm)	S.G Power Value (dBm)	Correction Factor (dB)	EIRP (dBm)
1	3760	-54.1	-13	-41.03	4.07	-36.96
2	5640	-52.65	-13	-37.33	4.81	-32.52
3	7520	-54.7	-13	-36.22	5.48	-30.74

REMARKS:

1. EIRP(dBm) = S.G Power Value (dBm) + Correction Factor (dB).
2. Correction Factor (dB) = Substitution Antenna Gain (dB) + Cable Loss (dB)

4.7 PEAK TO AVERAGE RATIO

4.7.1 LIMITS OF peak to average ratio MEASUREMENT

In measuring transmissions in this band using an average power technique, the peak to-average ratio (PAR) of the transmission may not exceed 13 dB

4.7.2 TEST SETUP

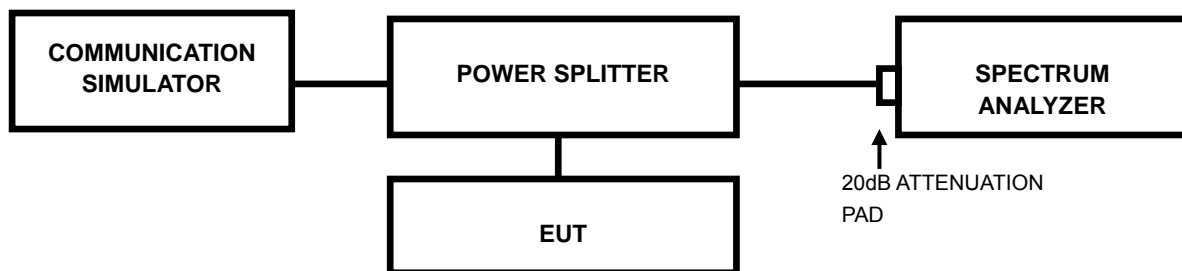

4.7.3 TEST PROCEDURES

1. Set resolution/measurement bandwidth \geq signal's occupied bandwidth;
2. Set the number of counts to a value that stabilizes the measured CCDF curve;
3. Record the maximum PAPR level associated with a probability of 0.1%.



4.7.4 TEST RESULTS

GSM

CHANNEL	FREQUENCY (MHz)	PEAK TO AVERAGE RATIO (dB)
661	1880	8.61

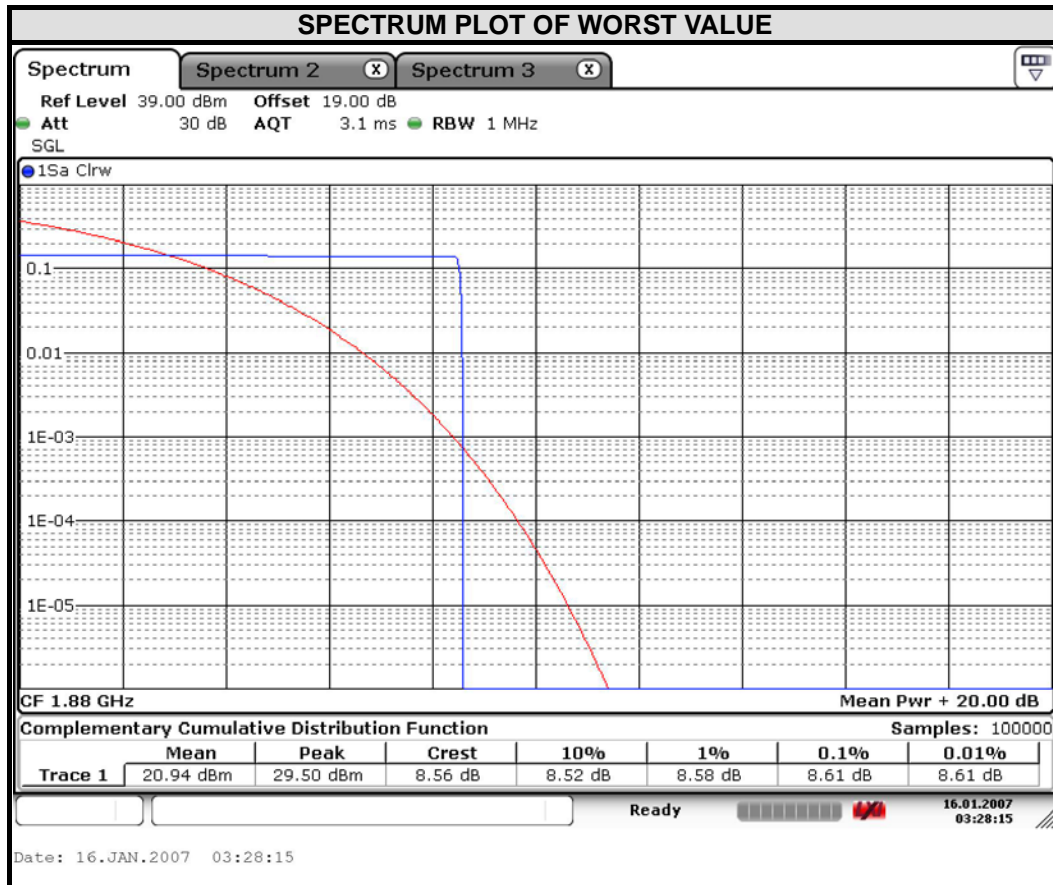



EDGE

CHANNEL	FREQUENCY (MHz)	PEAK TO AVERAGE RATIO (dB)
661	1880	7.71

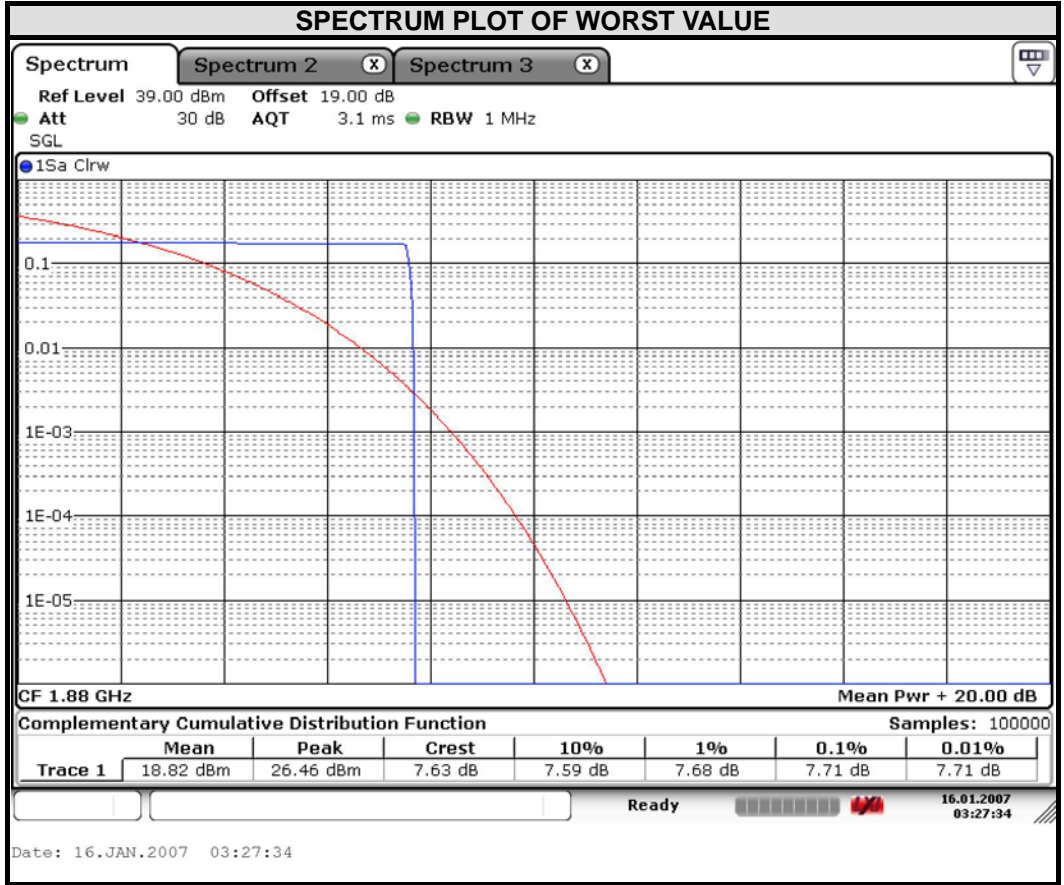



WCDMA

CHANNEL	FREQUENCY (MHz)	PEAK TO AVERAGE RATIO (dB)
9400	1880	3.01

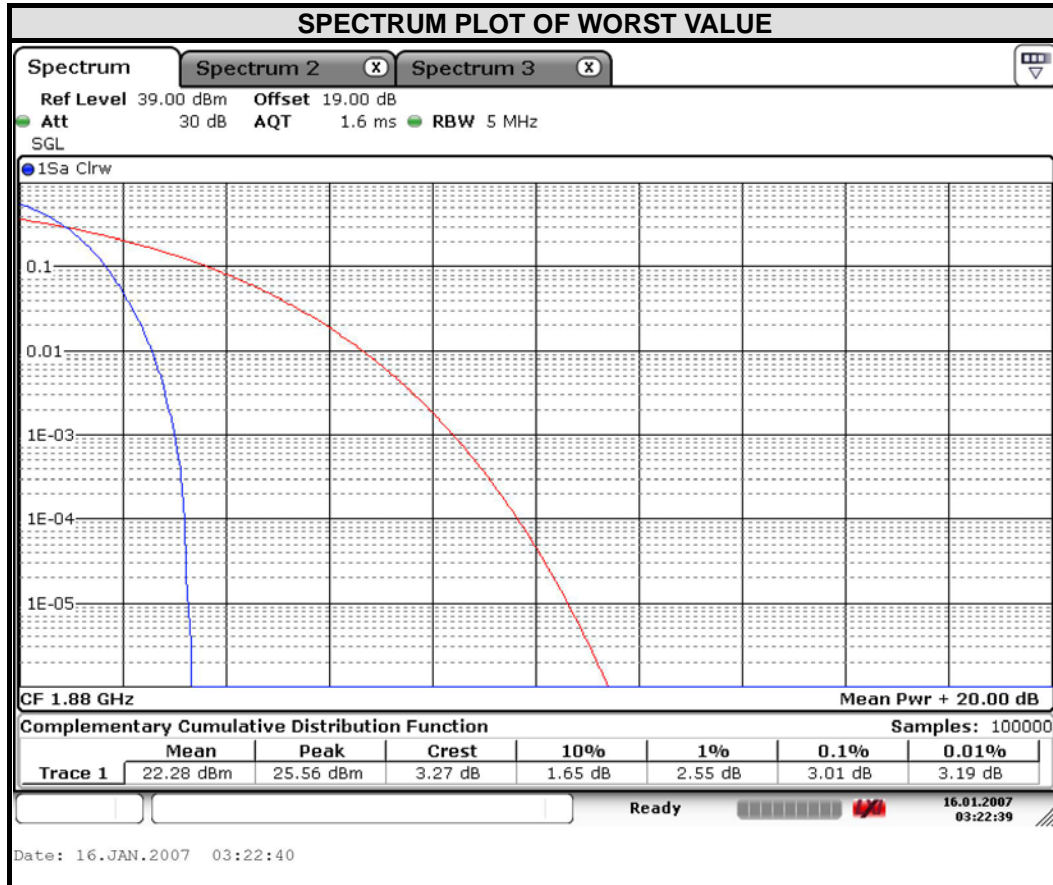



5 PHOTOGRAPHS OF THE TEST CONFIGURATION

Please refer to the attached file (Test Setup Photo).



**BUREAU
VERITAS**

Test Report No.: RF131024N040-2

6 INFORMATION ON THE TESTING LABORATORIES

We, Bureau Veritas Shenzhen Co., Ltd. Dongguan Branch, were founded in 2002 to provide our best service in EMC, Radio, Telecom and Safety consultation. Our laboratories are accredited and approved according to ISO/IEC 17025.

If you have any comments, please feel free to contact us at the following:

Dongguan EMC/RF Lab:

Tel: +86-769-85935656

Fax: +86-769-85931080

Email: customerservice.dg@cn.bureauveritas.com

Web Site: www.adt.com.tw

The address and road map of all our labs can be found in our web site also.



**BUREAU
VERITAS**

Test Report No.: RF131024N040-2

7 APPENDIX A – MODIFICATIONS RECORDERS FOR ENGINEERING CHANGES TO THE EUT BY THE LAB

No any modifications are made to the EUT by the lab during the test.

---END---