

# FCC Test Report

**APPLICANT** : Brightstar Corporation  
**EQUIPMENT** : mobile phone  
**BRAND NAME** : AVVIO  
**MODEL NAME** : AVVIO 9781  
**FCC ID** : WVBA9781  
**STANDARD** : FCC 47 CFR FCC Part 15 Subpart B  
**CLASSIFICATION** : Certification

The product was received on Jan. 30, 2013 and completely tested on Mar. 18, 2013. We, SPORTON INTERNATIONAL (KUNSHAN) INC., would like to declare that the tested sample has been evaluated in accordance with the procedures given in ANSI C63.4-2003 and shown the compliance with the applicable technical standards.

The test results in this report apply exclusively to the tested model / sample. Without written approval of SPORTON INTERNATIONAL (KUNSHAN) INC., the test report shall not be reproduced except in full.

Reviewed by:



Jones Tsai / Manager



**SPORTON INTERNATIONAL (KUNSHAN) INC.**  
**No. 3-2, PingXiang Road, Kunshan, Jiangsu Province, P.R.C.**



## TABLE OF CONTENTS

REVISION HISTORY..... 3

SUMMARY OF TEST RESULT ..... 4

1. GENERAL DESCRIPTION ..... 5

    1.1. Applicant..... 5

    1.2. Manufacturer ..... 5

    1.3. Feature of Equipment Under Test..... 6

    1.4. Product Specification of Equipment Under Test ..... 6

    1.5. Test Site ..... 7

    1.6. Applied Standards ..... 7

2. TEST CONFIGURATION OF EQUIPMENT UNDER TEST ..... 8

    2.1. Test Mode ..... 8

    2.2. Connection Diagram of Test System ..... 10

    2.3. Support Unit used in test configuration and system..... 11

    2.4. Test Software ..... 12

3. TEST RESULT..... 13

    3.1. Test of AC Conducted Emission Measurement ..... 13

    3.2. Test of Radiated Emission Measurement ..... 19

4. LIST OF MEASURING EQUIPMENT ..... 23

5. UNCERTAINTY OF EVALUATION ..... 24

APPENDIX A. PHOTOGRAPHS OF EUT

APPENDIX B. SETUP PHOTOGRAPHS





### SUMMARY OF TEST RESULT

Report Section	FCC Rule	IC Rule	Description	Limit	Result	Remark
3.1	15.107	7.2.4	AC Conducted Emission	< 15.107 limits < RSS-Gen table 2 limits	PASS	Under limit 4.98 dB at 0.350 MHz
3.2	15.109	7.2.3.2	Radiated Emission	< 15.109 limits or < RSS-Gen table 1 limits (Section 6)	PASS	Under limit 1.02 dB at 480.080 MHz for Quasi-Peak



## **1. General Description**

### **1.1. Applicant**

**Brightstar Corporation**  
9725 NW 117th Ave., Miami, Florida, United States

### **1.2. Manufacturer**

**LAKIA Networks CO., LTD.**  
2/F, Unit A, Technology Service Building, Software Garden, 1phase, Xiamen, Fujian, China Zip:  
361005

### 1.3. Feature of Equipment Under Test

Product Feature	
Equipment	mobile phone
Brand Name	AVVIO
Model Name	AVVIO 9781
FCC ID	WVBA9781
EUT supports Radios application	CDMA/EV-DO/WLAN 11bgn/Bluetooth
HW Version	9781_v2.0
SW Version	C9781S-user 2.3.5 GRJ90 eng.root.20130121.052207 test-keys
EUT Stage	Identical Prototype

**Remark:** The above EUT's information was declared by manufacturer. Please refer to the specifications or user's manual for more detailed description.

### 1.4. Product Specification of Equipment Under Test

Product Specification subjective to this standard	
Tx Frequency	CDMA2000 BC0: 824.70 MHz ~ 848.31 MHz CDMA2000 BC1: 1815.25 MHz ~ 1908.75 MHz 802.11b/g/n: 2412 MHz ~ 2462 MHz Bluetooth: 2402 MHz ~ 2480 MHz
Rx Frequency Range	CDMA2000 BC0: 869.70 MHz ~ 893.31 MHz CDMA2000 BC1: 1931.25 MHz ~ 1988.75 MHz 802.11b/g/n: 2412 MHz ~ 2462 MHz Bluetooth: 2402 MHz ~ 2480 MHz GPS : 1.57542 GHz FM: 88 MHz ~ 108 MHz
Antenna Type	WWAN : Dipole Antenna WLAN : IFA Antenna Bluetooth : IFA Antenna
Type of Modulation	CDMA2000 : QPSK CDMA2000 1xEV-DO : 8PSK 802.11b : DSSS (DBPSK / DQPSK / CCK) 802.11g/n : OFDM (BPSK / QPSK / 16QAM / 64QAM) Bluetooth BDR (1Mbps) : GFSK Bluetooth EDR (2Mbps) : $\pi/4$ -DQPSK Bluetooth EDR (3Mbps) : 8-DPSK GPS : BPSK FM

### 1.5. Test Site

<b>Test Site</b>	SPORTON INTERNATIONAL (KUNSHAN) INC.		
<b>Test Site Location</b>	No. 3-2, PingXiang Road, Kunshan, Jiangsu Province, P.R.C. TEL: +86-0512-5790-0158 FAX: +86-0512-5790-0958		
<b>Test Site No.</b>	<b>Sporton Site No.</b>		<b>FCC/IC Registration No.</b>
	CO01-KS	03CH01-KS	149928/4086E-1

### 1.6. Applied Standards

According to the specifications of the manufacturer, the EUT must comply with the requirements of the following standards:

- FCC 47 CFR FCC Part 15 Subpart B
- ANSI C63.4-2003

**Remark:** All test items were verified and recorded according to the standards and without any deviation during the test.

## 2. Test Configuration of Equipment Under Test

### 2.1. Test Mode

The EUT has been associated with peripherals pursuant to ANSI C63.4-2003 and configuration operated in a manner tended to maximize its emission characteristics in a typical application.

Frequency range investigated: conduction (150 KHz to 30 MHz), radiation (30MHz to the 5th harmonic of the highest fundamental frequency or to 40 GHz, whichever is lower).

The following tables are showing the test modes as the worst cases and recorded in this report.

Item	EUT Configuration	Test Condition		
		EMI AC	EMI RE<1G	EMI RE≥1G
1.	Charging Mode (EUT with adapter)	☒	☒	Note 1
2.	Data application transferred mode (EUT with PC)	☒	☒	☒

**Abbreviations:**

- EMI AC: AC conducted emissions
- EMI RE ≥ 1G: EUT radiated emissions ≥ 1GHz
- EMI RE < 1G: EUT radiated emissions < 1GHz

**Note 1:** Testing for this mode is not required or not the worst case.

**Remark:** For signal above 1GHz, the worst case was test item 2.



Test Items	EUT Configure Mode	Function Type
AC Conducted Emission	1/2	Mode 1: CDMA2000 BC0 Idle + Bluetooth Idle + WLAN Idle + USB Cable (Charging from Adapter) + Earphone + Camera<Fig. 1> Mode 2: CDMA2000 BC1 Idle + Bluetooth Idle + WLAN Idle + USB Cable (Charging from Adapter) + Earphone + MPEG4<Fig. 1> Mode 3: CDMA2000 BC0 Idle + Bluetooth Idle + WLAN Idle + USB Cable (Charging from Adapter) + Earphone + FM Rx<Fig. 2> Mode 4: CDMA2000 BC1 Idle + Bluetooth Idle + WLAN Idle + USB Cable (Data Link with PC) + Earphone + GPS Rx<Fig. 3>
Radiated Emissions < 1GHz	1/2	Mode 1: CDMA2000 BC0 Idle + Bluetooth Idle + WLAN Idle + USB Cable (Charging from Adapter) + Earphone + Camera<Fig. 1> Mode 2: CDMA2000 BC1 Idle + Bluetooth Idle + WLAN Idle + USB Cable (Charging from Adapter) + Earphone + MPEG4<Fig. 1> Mode 3: CDMA2000 BC0 Idle + Bluetooth Idle + WLAN Idle + USB Cable (Charging from Adapter) + Earphone + FM Rx<Fig. 2> Mode 4: CDMA2000 BC1 Idle + Bluetooth Idle + WLAN Idle + USB Cable (Data Link with PC) + Earphone + GPS Rx<Fig. 3>
Radiated Emissions ≥ 1GHz	2	Mode 1: CDMA2000 BC1 Idle + Bluetooth Idle + WLAN Idle + USB Cable (Data Link with PC) + Earphone + GPS Rx<Fig. 3>

**Remark:**

1. The worst case of AC Conducted Emission is mode 1; the test data of this mode was reported.
2. The USB Link mode of AC Conducted Emission is mode 4; the test data of this mode was also reported.
3. The worst case of Radiated Emissions is mode 4; only the test data of this mode was reported.
4. Data Link with PC means data application transferred mode between EUT and PC.

## 2.2. Connection Diagram of Test System

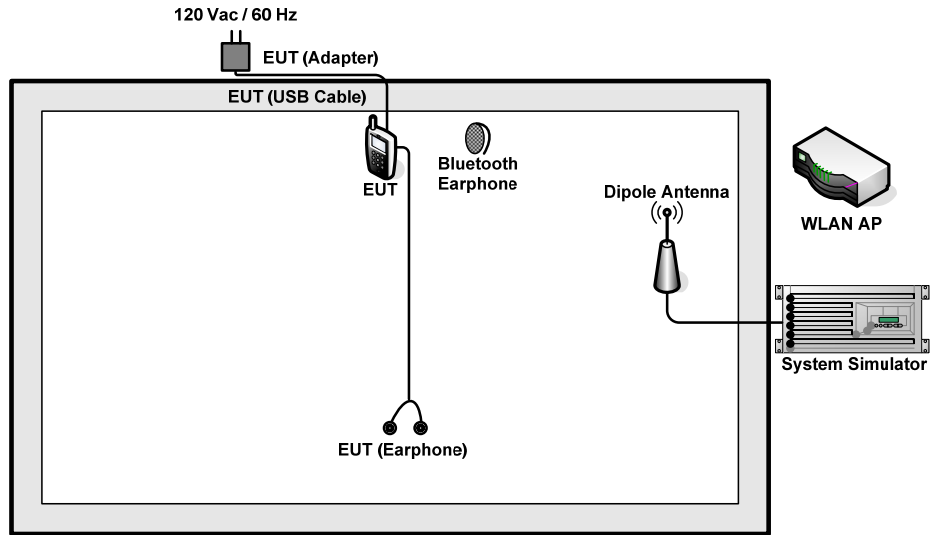

<Fig. 1>

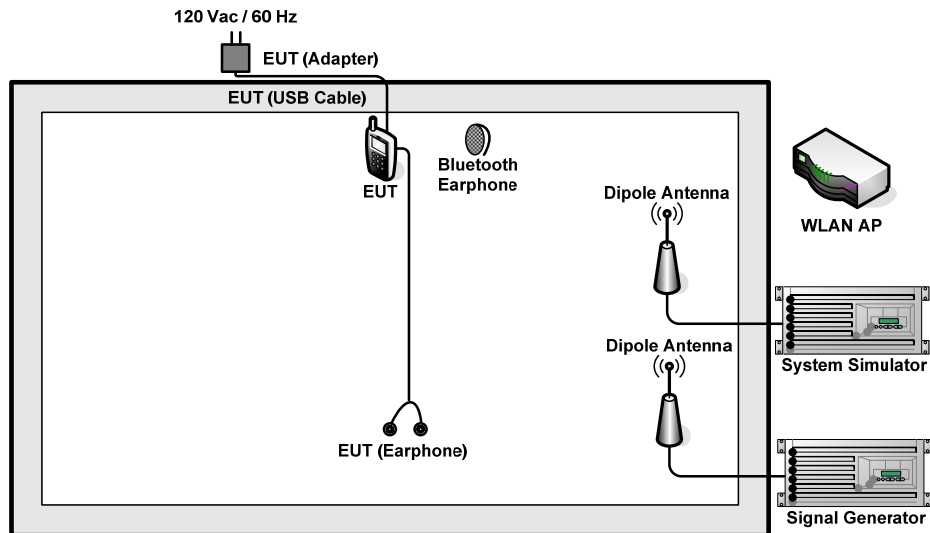

<Fig. 2>

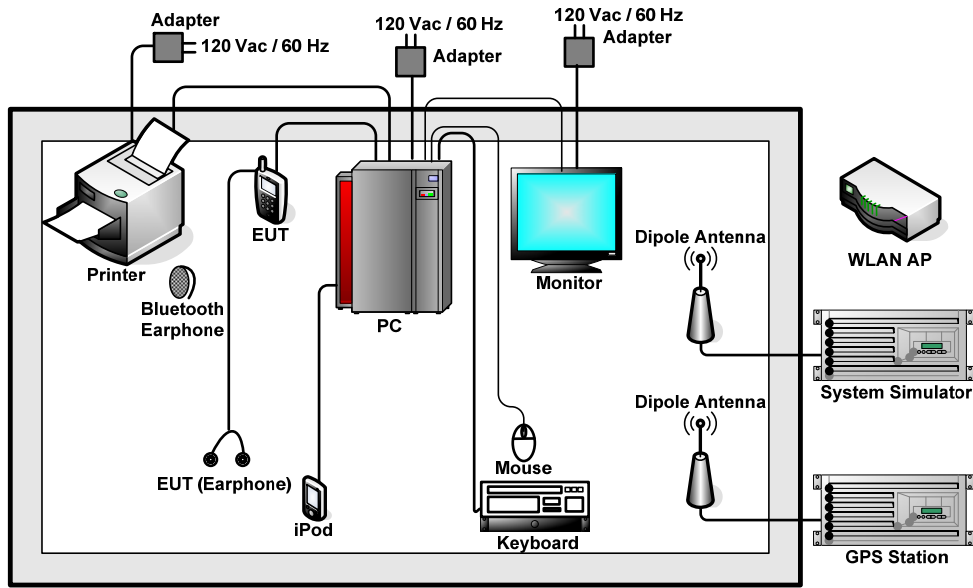

<Fig. 3>

### 2.3. Support Unit used in test configuration and system

Item	Equipment	Trade Name	Model Name	FCC ID	Data Cable	Power Cord
1.	System Simulator	R&S	CMU 200	N/A	N/A	Unshielded, 1.8 m
2.	GPS Station	ADIVIC	MP9000	N/A	N/A	Unshielded, 1.8 m
3.	Signal Generator	R&S	SMR40	N/A	N/A	Unshielded, 1.8 m
4.	WLAN AP	D-link	DIR-855	KA2DIR855A2	N/A	Unshielded, 1.8 m
5.	Bluetooth Earphone	Nokia	BH-102	PYAHS-107W	N/A	N/A
6.	Bluetooth Earphone	Nokia	BH-106	QTLBH-106	N/A	N/A
7.	PC	Dell	DCSM	FCC DoC	N/A	Unshielded, 1.8 m
8.	PC	Dell	MT320	FCC DoC	N/A	Unshielded, 1.8 m
9.	Monitor	Dell	E1910Hc	FCC DoC	Shielded, 1.2 m	Unshielded, 1.8 m
10.	(USB) Mouse	Dell	N231	FCC DoC	Shielded, 1.8 m	N/A
11.	(USB) Mouse	Dell	MO56UC	FCC DoC	Shielded, 1.8 m	N/A
12.	(USB) Keyboard	Dell	SK-8115	FCC DoC	Shielded, 1.8 m with core	N/A
13.	Printer	HP	Laser Jet 1018	FCC DoC	Shielded, 1.8 m	Unshielded, 1.8 m
14.	iPod	Apple	A1199	FCC DoC	Shielded, 1.2 m	N/A



## **2.4. Test Software**

The EUT was in CDMA2000 idle mode during the testing. The EUT was synchronized to the BCCH, and is in continuous receiving mode by setting system simulator's paging reorganization.

At the same time, the EUT was attached to the Bluetooth earphone or WLAN AP, and the following programs installed in the EUT were programmed during the test.

1. Execute the program, "Wintrax" under WIN7 installed in PC for files transfer with EUT via USB cable.
2. Execute GPS function to make the EUT receive continuous signals from GPS station.
3. Turn on FM function to make the EUT receive continuous signals from signal generator.
4. Execute "Windows Media Player" to play MPEG4 files.
5. Turn on camera to capture images.

### 3. Test Result

#### 3.1. Test of AC Conducted Emission Measurement

##### 3.1.1 Limits of AC Conducted Emission

For equipment that is designed to be connected to the public utility (AC) power line, the radio frequency voltage that is conducted back onto the AC power line on any frequency or frequencies within the band 150 KHz to 30 MHz shall not exceed the limits in the following table.

Frequency of emission (MHz)	Conducted limit (dBuV)	
	Quasi-peak	Average
0.15-0.5	66 to 56*	56 to 46*
0.5-5	56	46
5-30	60	50

\*Decreases with the logarithm of the frequency.

##### 3.1.2 Measuring Instruments

See list of measuring instruments of this test report.

##### 3.1.3 Test Procedure

1. The EUT was placed 0.4 meter from the conducting wall of the shielding room was kept at least 80 centimeters from any other grounded conducting surface.
2. Connect EUT to the power mains through a line impedance stabilization network (LISN).
3. All the support units are connecting to the other LISN.
4. The LISN provides 50 ohm coupling impedance for the measuring instrument.
5. The FCC states that a 50 ohm, 50 microhenry LISN should be used.
6. Both sides of AC line were checked for maximum conducted interference.
7. The frequency range from 150 KHz to 30 MHz was searched.
8. Set the test-receiver system to Peak Detect Function and specified bandwidth with Maximum Hold Mode.



3.1.5 Test Result of AC Conducted Emission

Test Mode :	Mode 1	Temperature :	19~20°C
Test Engineer :	Tom Wang	Relative Humidity :	39~40%
Test Voltage :	120Vac / 60Hz	Phase :	Line
Function Type :	CDMA2000 BC0 Idle + Bluetooth Idle + WLAN Idle + USB Cable (Charging from Adapter) + Earphone + Camera		
Remark :	All emissions not reported here are more than 10 dB below the prescribed limit.		

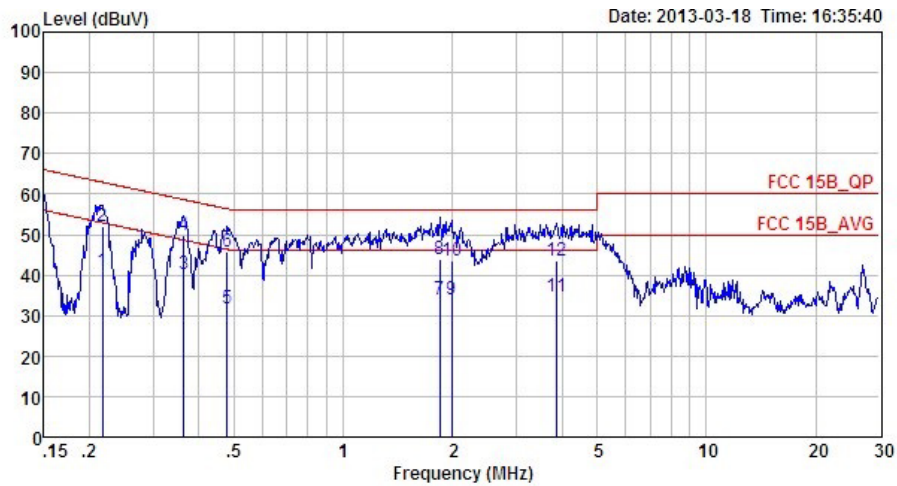

Site : CO01-KS  
 Condition: FCC 15B\_QP LISN\_L\_2000601 LINE  
 Project : (FC) 313006  
 Mode : model

	Freq	Level	Over Limit	Limit Line	Read Level	LISN Factor	Cable Loss	Remark
	MHz	dBuV	dB	dBuV	dBuV	dB	dB	
1	0.22	40.88	-12.04	52.92	30.80	0.02	10.06	Average
2	0.22	51.98	-10.94	62.92	41.90	0.02	10.06	QP
3 *	0.36	40.19	-8.46	48.65	30.10	0.02	10.07	Average
4	0.36	49.69	-8.96	58.65	39.60	0.02	10.07	QP
5	0.48	31.90	-14.46	46.36	21.80	0.02	10.08	Average
6	0.48	45.60	-10.76	56.36	35.50	0.02	10.08	QP
7	1.85	33.98	-12.02	46.00	23.81	0.03	10.14	Average
8	1.85	43.78	-12.22	56.00	33.61	0.03	10.14	QP
9	1.99	33.79	-12.21	46.00	23.60	0.04	10.15	Average
10	1.99	43.39	-12.61	56.00	33.20	0.04	10.15	QP
11	3.86	34.85	-11.15	46.00	24.60	0.06	10.19	Average
12	3.86	43.45	-12.55	56.00	33.20	0.06	10.19	QP



Test Mode :	Mode 1	Temperature :	19~20°C
Test Engineer :	Tom Wang	Relative Humidity :	39~40%
Test Voltage :	120Vac / 60Hz	Phase :	Neutral
Function Type :	CDMA2000 BC0 Idle + Bluetooth Idle + WLAN Idle + USB Cable (Charging from Adapter) + Earphone + Camera		
Remark :	All emissions not reported here are more than 10 dB below the prescribed limit.		

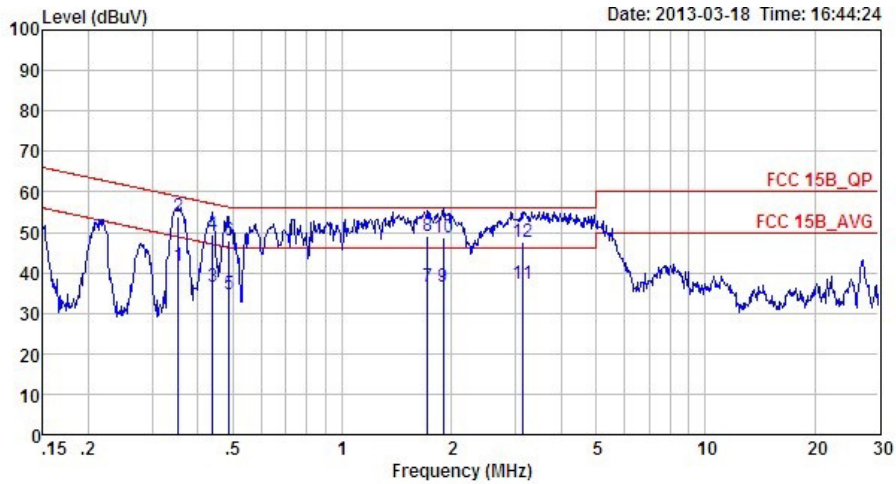

Site : CO01-KS  
 Condition: FCC 15B\_QP LISN\_N\_2000601 NEUTRAL  
 Project : (FC) 313006  
 Mode : model

	Freq	Level	Over	Limit	Read	LISN	Cable	
	MHz	dBuV	Limit	Line	Level	Factor	Loss	Remark
			dB	dBuV	dBuV	dB	dB	
1	0.35	41.79	-7.08	48.87	31.70	0.02	10.07	Average
2 *	0.35	53.89	-4.98	58.87	43.80	0.02	10.07	QP
3	0.44	36.50	-10.57	47.07	26.40	0.02	10.08	Average
4	0.44	49.60	-7.47	57.07	39.50	0.02	10.08	QP
5	0.49	34.60	-11.59	46.19	24.50	0.02	10.08	Average
6	0.49	47.90	-8.29	56.19	37.80	0.02	10.08	QP
7	1.72	36.66	-9.34	46.00	26.50	0.03	10.13	Average
8	1.72	49.06	-6.94	56.00	38.90	0.03	10.13	QP
9	1.90	36.68	-9.32	46.00	26.50	0.03	10.15	Average
10	1.90	48.78	-7.22	56.00	38.60	0.03	10.15	QP
11	3.14	37.14	-8.86	46.00	26.90	0.05	10.19	Average
12	3.14	47.44	-8.56	56.00	37.20	0.05	10.19	QP





Test Mode :	Mode 4	Temperature :	19~20°C
Test Engineer :	Tom Wang	Relative Humidity :	39~40%
Test Voltage :	120Vac / 60Hz	Phase :	Line
Function Type :	CDMA2000 BC1 Idle + Bluetooth Idle + WLAN Idle + USB Cable (Data Link with PC) + Earphone + GPS Rx		
Remark :	All emissions not reported here are more than 10 dB below the prescribed limit.		

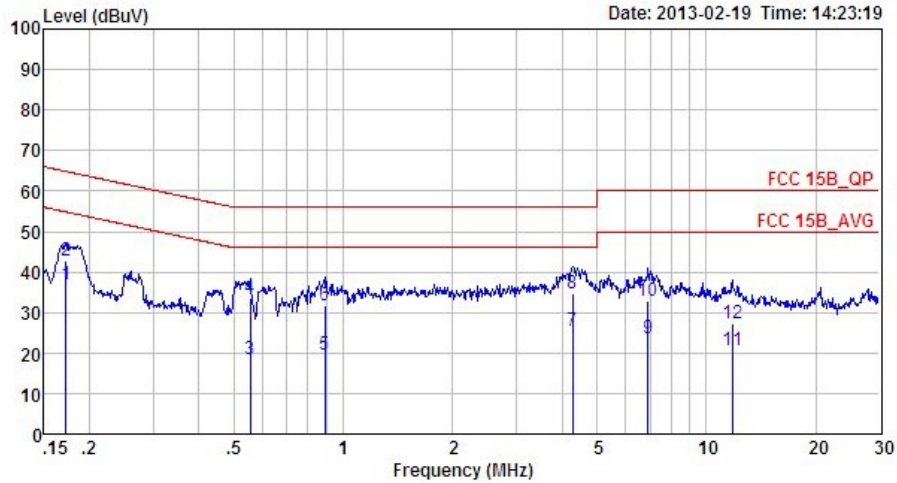

Site : CO01-KS  
 Condition: FCC 15B\_QP LISN\_L\_2000601 LINE  
 Project : (FC) 313006  
 Mode : mode4

	Freq	Level	Over Limit	Limit Line	Read Level	LISN Factor	Cable Loss	Remark
	MHz	dBuV	dB	dBuV	dBuV	dB	dB	
1 *	0.17	36.98	-17.88	54.86	26.90	0.03	10.05	Average
2	0.17	42.88	-21.98	64.86	32.80	0.03	10.05	QP
3	0.56	18.61	-27.39	46.00	8.50	0.02	10.09	Average
4	0.56	33.71	-22.29	56.00	23.60	0.02	10.09	QP
5	0.89	19.73	-26.27	46.00	9.60	0.02	10.11	Average
6	0.89	31.63	-24.37	56.00	21.50	0.02	10.11	QP
7	4.29	25.35	-20.65	46.00	15.10	0.06	10.19	Average
8	4.29	34.55	-21.45	56.00	24.30	0.06	10.19	QP
9	6.91	23.70	-26.30	50.00	13.40	0.10	10.20	Average
10	6.91	32.70	-27.30	60.00	22.40	0.10	10.20	QP
11	11.81	20.59	-29.41	50.00	10.00	0.25	10.34	Average
12	11.81	27.19	-32.81	60.00	16.60	0.25	10.34	QP



Test Mode :	Mode 4	Temperature :	19~20°C
Test Engineer :	Tom Wang	Relative Humidity :	39~40%
Test Voltage :	120Vac / 60Hz	Phase :	Neutral
Function Type :	CDMA2000 BC1 Idle + Bluetooth Idle + WLAN Idle + USB Cable (Data Link with PC) + Earphone + GPS Rx		
Remark :	All emissions not reported here are more than 10 dB below the prescribed limit.		

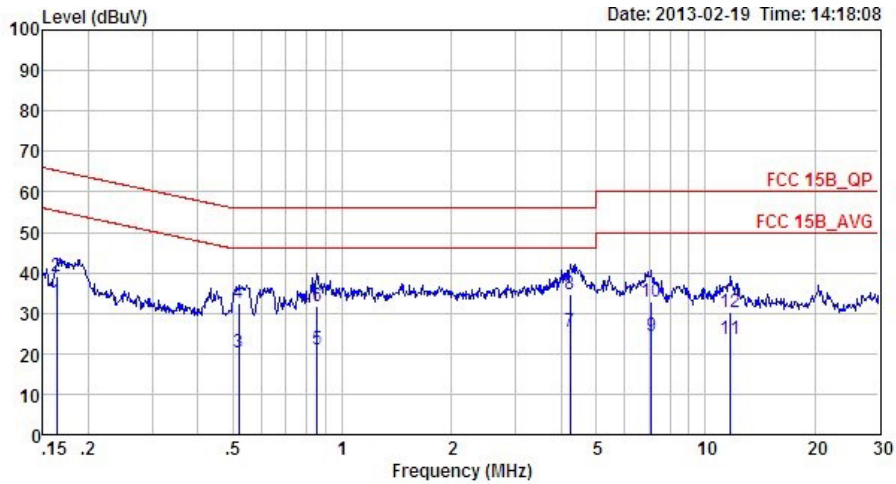

Site : CO01-KS  
 Condition: FCC 15B\_QP LISN\_N\_2000601 NEUTRAL  
 Project : (FC) 313006  
 Mode : mode4

	Freq	Level	Over	Limit	Read	LISN	Cable	
	MHz	dBuV	dB	dBuV	dBuV	dB	dB	Remark
1	0.16	32.77	-22.53	55.30	22.70	0.02	10.05	Average
2	0.16	39.17	-26.13	65.30	29.10	0.02	10.05	QP
3	0.52	20.30	-25.70	46.00	10.19	0.02	10.09	Average
4	0.52	32.40	-23.60	56.00	22.29	0.02	10.09	QP
5	0.85	21.03	-24.97	46.00	10.90	0.02	10.11	Average
6	0.85	31.73	-24.27	56.00	21.60	0.02	10.11	QP
7 *	4.25	25.36	-20.64	46.00	15.10	0.07	10.19	Average
8	4.25	34.76	-21.24	56.00	24.50	0.07	10.19	QP
9	7.10	24.53	-25.47	50.00	14.20	0.13	10.20	Average
10	7.10	32.73	-27.27	60.00	22.40	0.13	10.20	QP
11	11.74	23.75	-26.25	50.00	13.11	0.31	10.33	Average
12	11.74	30.15	-29.85	60.00	19.51	0.31	10.33	QP

## 3.2. Test of Radiated Emission Measurement

### 3.2.1. Limit of Radiated Emission

The emissions from an unintentional radiator shall not exceed the field strength levels specified in the following table:

Frequency (MHz)	Field Strength (microvolts/meter)	Measurement Distance (meters)
30 – 88	100	3
88 – 216	150	3
216 - 960	200	3
Above 960	500	3

### 3.2.2. Measuring Instruments

See list of measuring instruments of this test report.

### 3.2.3. Test Procedures

1. The EUT was placed on a turntable with 0.8 meter above ground.
2. The EUT was set 3 meters from the interference receiving antenna, which was mounted on the top of a variable height antenna tower.
3. The table was rotated 360 degrees to determine the position of the highest radiation.
4. The antenna height is adjusted between one to four meters above ground to find the maximum value of the field strength for both horizontal polarization and vertical polarization of the antenna.
5. For each suspected emission, the EUT was arranged to its worst case and then tune the antenna tower (from 1 m to 4 m) and turntable (from 0 degree to 360 degrees) to find the maximum reading.
6. Set the test-receiver system to Peak Detect Function and specified bandwidth with Maximum Hold Mode.
7. If the emission level of the EUT in peak mode was 3 dB lower than the limit specified, peak values of EUT will be reported. Otherwise, the emission will be repeated by using the quasi-peak method and reported.
8. Emission level (dBuV/m) = 20 log Emission level (uV/m)
9. Corrected Reading: Antenna Factor + Cable Loss + Read Level - Preamp Factor= Level

### 3.2.4. Test Setup of Radiated Emission

For radiated emissions from 30MHz to 1GHz

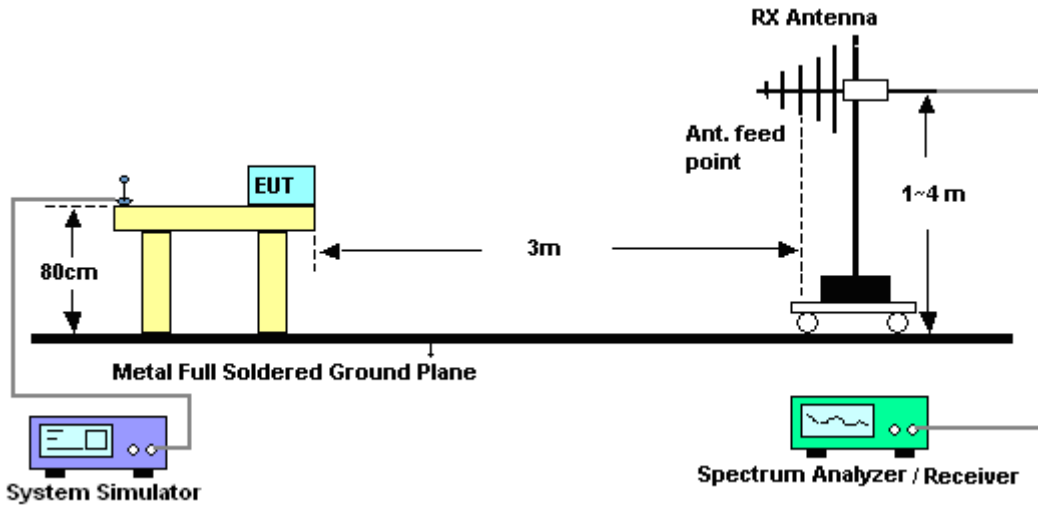

For radiated emissions above 1GHz

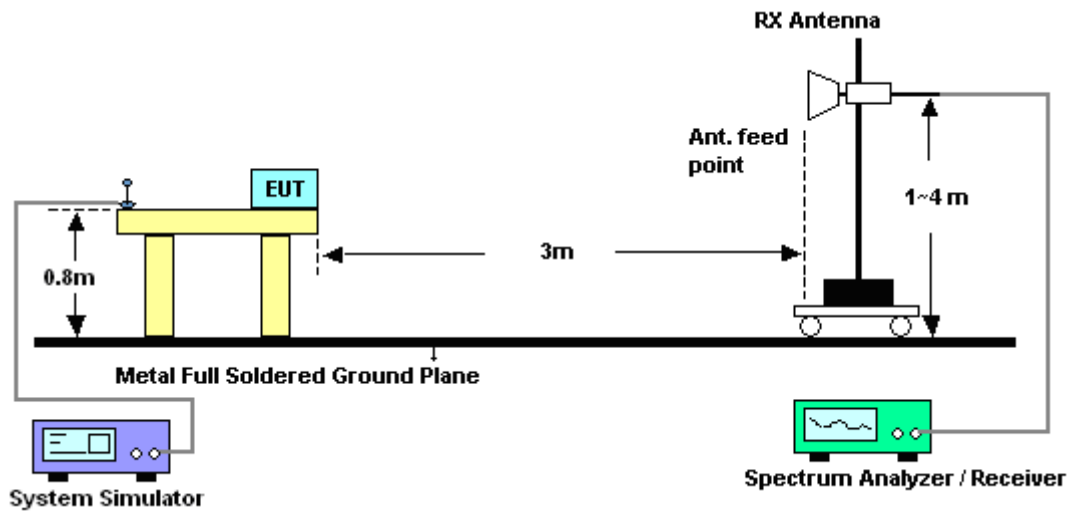



3.2.5. Test Result of Radiated Emission

Test Mode :	Mode 4	Temperature :	22~23°C
Test Engineer :	Steven Hao	Relative Humidity :	41~42%
Test Distance :	3m	Polarization :	Horizontal
Function Type :	CDMA2000 BC1 Idle + Bluetooth Idle + WLAN Idle + USB Cable (Data Link with PC) + Earphone + GPS Rx		

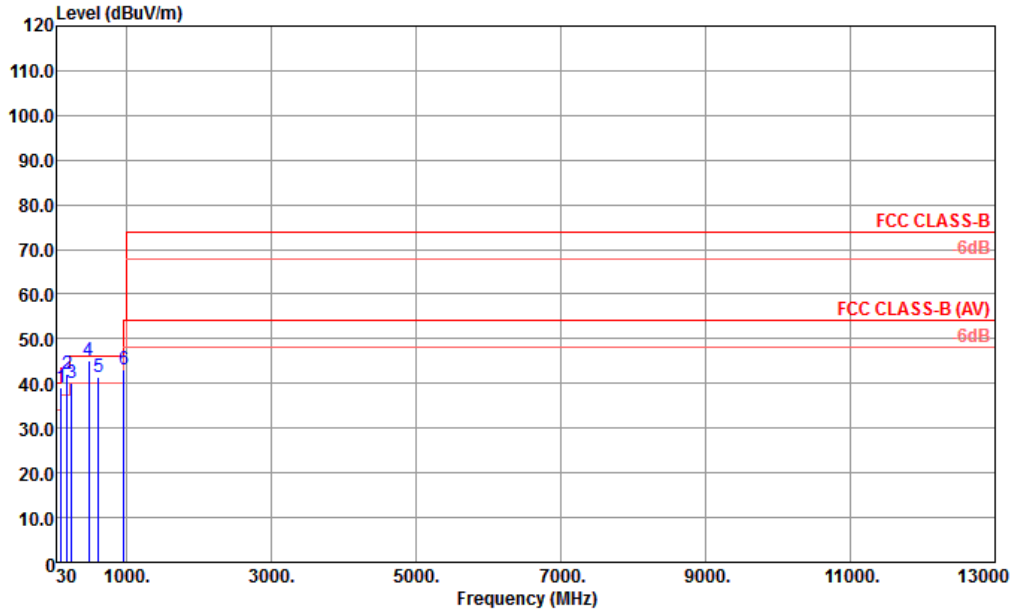

Site : 03CH01-KS  
 Condition : FCC CLASS-B 3m LF\_ANT-100803 HORIZONTAL  
 Project : (FC) 313006  
 Mode : Mode 4

	Freq	Level	Over Limit	Limit Line	ReadAntenna Level	Cable Factor	Preamp Loss	A/Pos	T/Pos	Remark
	MHz	dBuV/m	dB	dBuV/m	dBuV	dB/m	dB	dB	cm	deg
1 !	95.96	39.20	-4.30	43.50	62.35	9.90	0.56	33.61	200	85 QP
2 !	181.32	42.06	-1.44	43.50	66.44	8.40	0.78	33.56	100	87 QP
3 !	242.43	40.05	-5.95	46.00	60.97	11.63	0.89	33.44	---	Peak
4 !	480.08	44.98	-1.02	46.00	60.00	16.86	1.27	33.15	100	265 QP
5 !	614.91	41.32	-4.68	46.00	54.20	18.66	1.40	32.94	---	Peak
6	960.23	43.02	-10.98	54.00	52.91	20.78	1.76	32.43	---	Peak



Test Mode :	Mode 4	Temperature :	22~23°C
Test Engineer :	Steven Hao	Relative Humidity :	41~42%
Test Distance :	3m	Polarization :	Vertical
Function Type :	CDMA2000 BC1 Idle + Bluetooth Idle + WLAN Idle + USB Cable (Data Link with PC) + Earphone + GPS Rx		

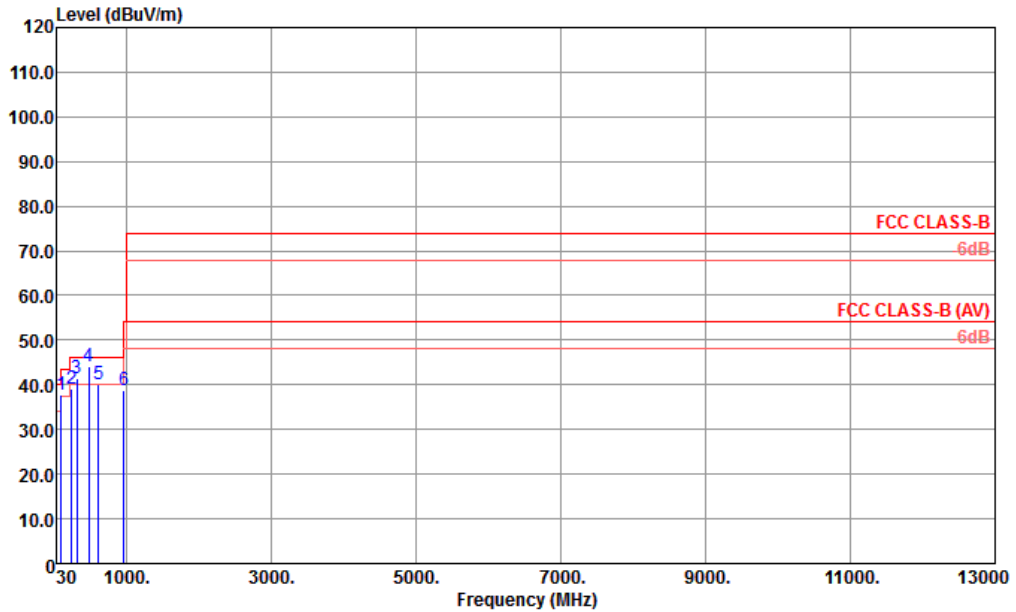

Site : 03CH01-KS  
 Condition : FCC CLASS-B 3m LF\_ANT-100803 VERTICAL  
 Project : (FC) 313006  
 Mode : Mode 4

	Freq	Level	Over	Limit	ReadAntenna	Cable	Preamp	A/Pos	T/Pos	Remark	
	MHz	dBuV/m	dB	dBuV/m	dBuV	dB/m	dB	dB	cm	deg	
1 !	95.96	37.72	-5.78	43.50	60.87	9.90	0.56	33.61	---	---	Peak
2	240.49	39.27	-6.73	46.00	60.29	11.54	0.89	33.45	---	---	Peak
3 !	314.21	41.44	-4.56	46.00	60.43	13.36	1.01	33.36	---	---	Peak
4 !	480.08	44.28	-1.72	46.00	59.30	16.86	1.27	33.15	200	160	QP
5	614.91	39.98	-6.02	46.00	52.86	18.66	1.40	32.94	---	---	Peak
6	960.23	38.72	-15.28	54.00	48.61	20.78	1.76	32.43	---	---	Peak

## 4. List of Measuring Equipment

Instrument	Manufacturer	Model No.	Serial No.	Characteristics	Calibration Date	Test Date	Due Date	Remark
EMI Receiver	R&S	ESCI7	100768	9kHz~7GHz	Jun. 01, 2012	Feb. 19, 2013~ Mar. 18, 2013	May 31, 2013	Conduction (CO01-KS)
LISN	MessTec	AN3016	60103	9kHz~30MHz	Dec. 29, 2012	Feb. 19, 2013~ Mar. 18, 2013	Dec. 28, 2013	Conduction (CO01-KS)
LISN	MessTec	AN3016	60105	9kHz~30MHz	Dec. 29, 2012	Feb. 19, 2013~ Mar. 18, 2013	Dec. 28, 2013	Conduction (CO01-KS)
AC Power Source	Chroma	61602	ABP0000008 11	N/A	Nov. 15, 2012	Feb. 19, 2013~ Mar. 18, 2013	Nov. 14, 2013	Conduction (CO01-KS)
System Simulator	R&S	CMU200	837587/066	2G Full-Band	Dec. 29, 2012	Feb. 19, 2013~ Mar. 18, 2013	Dec. 28, 2013	Conduction (CO01-KS)
GPS Station	ADIVIC	MP9000	MP9000-111 046	N/A	N/A	Feb. 19, 2013~ Mar. 18, 2013	N/A	Conduction (CO01-KS)
Signal Generator	R&S	SMR40	100455	10MHz~40GHz	Dec. 29, 2012	Feb. 19, 2013~ Mar. 18, 2013	Dec. 28, 2013	Conduction (CO01-KS)
EMI Test Receiver	R&S	ESCI	100534	9kHz~3GHz	Nov. 08, 2012	Feb. 27, 2013	Nov. 07, 2013	Radiation (03CH01-KS)
Spectrum Analyzer	R&S	FSP30	100400	9kHz~30GHz	Jun. 01, 2012	Feb. 27, 2013	May 31, 2013	Radiation (03CH01-KS)
Bilog Antenna	SCHAFFNER	CBL6112D	23182	25MHz~2GHz	Dec. 07, 2012	Feb. 27, 2013	Dec. 06, 2013	Radiation (03CH01-KS)
Double Ridge Horn Antenna	EMCO	3117	00075959	1GHz~18GHz	Jan. 06, 2013	Feb. 27, 2013	Jan. 05, 2014	Radiation (03CH01-KS)
Amplifier	com-power	PA-103A	161069	1MHz~1GHz	Jun. 01, 2012	Feb. 27, 2013	May 31, 2013	Radiation (03CH01-KS)
Amplifier	Agilent	8449B	3008A02370	1GHz~26.5GHz	Dec. 29, 2012	Feb. 27, 2013	Dec. 28, 2013	Radiation (03CH01-KS)
Signal Generator	R&S	SMR40	100455	10MHz~40GHz	Dec. 29, 2012	Feb. 27, 2013	Dec. 28, 2013	Radiation (03CH01-KS)
GPS Station	ADIVIC	MP9000	MP9000-111 046	N/A	N/A	Feb. 27, 2013	N/A	Radiation (03CH01-KS)
System Simulator	R&S	CMU200	837587/066	2G Full-Band	Dec. 29, 2012	Feb. 27, 2013	Dec. 28, 2013	Radiation (03CH01-KS)

## 5. Uncertainty of Evaluation

### Uncertainty of Conducted Emission Measurement (150 KHz ~ 30 MHz)

Measuring Uncertainty for a Level of Confidence of 95% ( $U = 2Uc(y)$ )	2.26
---	------

### Uncertainty of Radiated Emission Measurement (30 MHz ~ 1000 MHz)

Measuring Uncertainty for a Level of Confidence of 95% ( $U = 2Uc(y)$ )	2.54
---	------

### Uncertainty of Radiated Emission Measurement (1 GHz ~ 40 GHz)

Measuring Uncertainty for a Level of Confidence of 95% ( $U = 2Uc(y)$ )	4.72
---	------





## **Appendix A. Photographs of EUT**

Please refer to Sporton report number EP313006 as below.