



# FCC SAR Test Report

**APPLICANT** : Brightstar Corporation  
**EQUIPMENT** : mobile phone  
**BRAND NAME** : AVVIO  
**MODEL NAME** : AVVIO 9781  
**FCC ID** : WVBA9781  
**STANDARD** : FCC 47 CFR Part 2 (2.1093)  
ANSI/IEEE C95.1-1992  
IEEE 1528-2003  
FCC OET Bulletin 65 Supplement C (Edition 01-01)

The product was completely tested on Feb. 28, 2013. We, SPORTON INTERNATIONAL (SHENZHEN) INC., would like to declare that the tested sample has been evaluated in accordance with the procedures and shown the compliance with the applicable technical standards.

The test results in this report apply exclusively to the tested model / sample. Without written approval of SPORTON INTERNATIONAL (SHENZHEN) INC., the test report shall not be reproduced except in full.

Reviewed by:

Jones Tsai / Manager

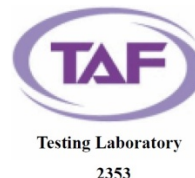

**SPORTON INTERNATIONAL (SHENZHEN) INC.**

No. 101, Complex Building C, Guanglong Village, Xili Town, Nanshan District, Shenzhen, Guangdong, P.R.C.



**Table of Contents**

**1. Statement of Compliance .....4**

**2. Administration Data .....5**

    2.1 Testing Laboratory.....5

    2.2 Applicant .....5

    2.3 Manufacturer.....5

    2.4 Application Details.....5

**3. General Information .....6**

    3.1 Description of Equipment Under Test (EUT) .....6

    3.2 Maximum RF output power among production units.....7

    3.3 Product Photos .....8

    3.4 Applied Standard.....8

    3.5 Device Category and SAR Limits .....8

    3.6 Test Conditions.....8

**4. Specific Absorption Rate (SAR).....9**

    4.1 Introduction .....9

    4.2 SAR Definition.....9

**5. SAR Measurement System.....10**

    5.1 E-Field Probe .....11

    5.2 Data Acquisition Electronics (DAE) .....12

    5.3 Robot .....12

    5.4 Measurement Server.....12

    5.5 Phantom.....13

    5.6 Device Holder .....13

    5.7 Data Storage and Evaluation .....14

    5.8 Test Equipment List.....16

**6. Tissue Simulating Liquids.....17**

**7. SAR System Verification .....18**

    7.1 Purpose of System Performance check .....18

    7.2 System Setup.....18

    7.3 SAR System Verification Results .....19

**8. EUT Testing Position .....20**

    8.1 Define two imaginary lines on the handset.....20

    8.2 Cheek Position.....21

    8.3 Tilted Position.....21

    8.4 Body Worn Position.....22

**9. Measurement Procedures .....23**

    9.1 Spatial Peak SAR Evaluation.....23

    9.2 Power Reference Measurement.....24

    9.3 Area & Zoom Scan Procedures.....24

    9.4 Volume Scan Procedures.....25

    9.5 SAR Averaged Methods.....25

    9.6 Power Drift Monitoring.....25

**10. SAR Test Configurations.....28**

    10.1 Exposure Positions Consideration .....28

**11. Conducted RF Output Power (Unit: dBm).....26**

**12. SAR Test Results .....28**

    12.1 Test Records for Head SAR Test.....30

    12.2 Test Records for Hotspot SAR Test.....31

    12.3 Test Records for Body-worn SAR Test .....32

    12.4 Repeated SAR Measurement .....33

    12.5 Highest SAR Plot .....33

    12.6 Simultaneous Multi-band Transmission Analysis .....37

**13. Uncertainty Assessment .....41**

**14. References.....43**

**Appendix A. Plots of System Performance Check**

**Appendix B. Plots of SAR Measurement**

**Appendix C. DASYS Calibration Certificate**

**Appendix D. Product Photos**

**Appendix E. Test Setup Photos**



### Revision History

REPORT NO.	VERSION	DESCRIPTION	ISSUED DATE
FA313006	Rev. 01	Initial issue of report	Mar. 22, 2013

### 1. Statement of Compliance

The maximum results of Specific Absorption Rate (SAR) found during testing for **Brightstar Corporation**; **DUT: mobile phone; Brand Name: AVVIO; Model Name: AVVIO 9781**, are as follows.

<Highest Reported standalone SAR Summary>

Exposure Position	Frequency Band	Highest Reported 1g-SAR (W/kg)	Equipment Class	Highest Reported 1g-SAR (W/kg)
Head	CDMA2000 BC0	1.02	PCE	1.50
	CDMA2000 BC1	1.50		
	WLAN, 2412 - 2462 MHz	0.13	DTS	0.13
Hotspot (1cm Gap)	CDMA2000 BC0	1.48	PCE	1.48
	CDMA2000 BC1	1.27		
	WLAN, 2412 - 2462 MHz	0.05	DTS	0.05
Body-worn (1cm Gap)	CDMA2000 BC0	1.37	PCE	1.37
	CDMA2000 BC1	1.34		
	WLAN, 2412 - 2462 MHz	0.05	DTS	0.05

<Highest Simultaneous transmission SAR>

Exposure Position	Frequency Band	Equipment Class	Highest Reported Simultaneous Transmission 1g-SAR (W/kg)
Head	CDMA2000 BC1	PCE	1.56
	WLAN, 2412 - 2462 MHz	DTS	

Exposure Position	Frequency Band	Equipment Class	Highest Reported Simultaneous Transmission 1g-SAR (W/kg)
Head	CDMA2000 BC1	PCE	1.52
	Bluetooth, 2402 - 2480 MHz	DSS	

**Remark:**

The highest simultaneous transmission is scalar summation of reported standalone SAR per FCC KDB 690783 D01 v01r02, and scalar SAR summation of all possible simultaneous transmission scenarios are < 1.6W/kg.

This device is in compliance with Specific Absorption Rate (SAR) for general population/uncontrolled exposure limits (1.6 W/kg) specified in FCC 47 CFR part 2 (2.1093) and ANSI/IEEE C95.1-1992, and had been tested in accordance with the measurement methods and procedures specified in IEEE 1528-2003 and FCC OET Bulletin 65 Supplement C (Edition 01-01).



## 2. Administration Data

### 2.1 Testing Laboratory

Test Site	SPORTON INTERNATIONAL (SHENZHEN) INC.
Test Site Location	No. 101, Complex Building C, Guanglong Village, Xili Town, Nanshan District, Shenzhen, Guangdong, P.R.C. TEL: +86-755-8637-9589 FAX: +86-755-8637-9595

### 2.2 Applicant

Company Name	Brightstar Corporation
Address	9725 NW 117th Ave., Miami, Florida, United States

### 2.3 Manufacturer

Company Name	LAKIA Networks CO., LTD.
Address	2/F, Unit A, Technology Service Building, Software Garden, 1phase, Xiamen, Fujian, China Zip: 361005

### 2.4 Application Details

Date of Start during the Test	Feb. 16, 2013
Date of End during the Test	Feb. 28, 2013



### 3. General Information

#### 3.1 Description of Equipment Under Test (EUT)

Product Feature & Specification	
EUT	mobile phone
Brand Name	AVVIO
Model Name	AVVIO 9781
FCC ID	WVBA9781
TX Frequency	CDMA2000 BC0: 824.7 MHz ~ 848.31 MHz CDMA 2000 BC1: 1851.25 MHz ~ 1908.75 MHz WLAN 2.4GHz Band: 2412 MHz ~ 2462 MHz Bluetooth: 2402 MHz ~ 2480 MHz
Antenna Type	WWAN: Dipole Antenna WLAN: IFA Antenna Bluetooth: IFA Antenna
HW Version	9781_v2.0
SW Version	C9781S-user 2.3.5 GRJ90 eng.root.20130121.052207 test-keys
Uplink Modulations	CDMA2000 1xRTT: QPSK CDMA2000 1xEV-DO: 8PSK 802.11b: DSSS (DBPSK / DQPSK / CCK) 802.11g/n: OFDM (BPSK / QPSK / 16QAM / 64QAM) Bluetooth BDR (1Mbps) : GFSK Bluetooth EDR (2Mbps) : $\pi/4$ -DQPSK Bluetooth EDR (3Mbps) : 8-DPSK
<b>Remark:</b> The above EUT's information was declared by manufacturer. Please refer to the specifications or user's manual for more detailed description.	

**3.2 Maximum RF output power among production units**

Maximum Target power for Production Unit		
Band	CDMA2000 BC0	CDMA2000 BC1
1xRTT RC1 SO55	22	24
1xRTT RC3 SO55	23	24
1xRTT RC3 SO32(+ F-SCH)	23	24
1xRTT RC3 SO32(+SCH)	22	24
1xEV-DO Rev 0	23	24
1xEV-DO Rev A	22	24

Maximum Target Average Power for Production Unit				
Mode / Band	IEEE 802.11			
	a	b	g	n-HT20
2.4 GHz WLAN		12	10	10

Maximum Target Average Power for Production Unit			
Mode / Band	Bluetooth (dBm)		
	1Mbps (GFSK)	2Mbps ( $\pi/4$ -DQPSK)	3Mbps (8-DPSK)
2.4 GHz Bluetooth	-3	-3	-3



**3.3 Product Photos**

Please refer to Appendix D.

**3.4 Applied Standard**

The Specific Absorption Rate (SAR) testing specification, method, and procedure for this device is in accordance with the following standards:

- FCC 47 CFR Part 2 (2.1093)
- ANSI/IEEE C95.1-1992
- IEEE 1528-2003
- FCC OET Bulletin 65 Supplement C (Edition 01-01)
- FCC KDB 447498 D01 v05
- FCC KDB 648474 D04v01
- FCC KDB 248227 D01 v01r02
- FCC KDB 941225 D01 v02
- FCC KDB 941225 D06 v01
- FCC KDB 865664 D01 v01

**3.5 Device Category and SAR Limits**

This device belongs to portable device category because its radiating structure is allowed to be used within 20 centimeters of the body of the user. Limit for General Population/Uncontrolled exposure should be applied for this device, it is 1.6 W/kg as averaged over any 1 gram of tissue.

**3.6 Test Conditions**

**3.6.1 Ambient Condition**

Ambient Temperature	20 to 24 °C
Humidity	< 60 %

**3.6.2 Test Configuration**

For WWAN SAR testing, the device was controlled by using a base station emulator. Communication between the device and the emulator was established by air link. The distance between the EUT and the antenna of the emulator is larger than 50 cm and the output power radiated from the emulator antenna is at least 30 dB smaller than the output power of EUT.

During WLAN SAR testing EUT is configured with the WLAN continuous TX tool.

For WLAN SAR testing, WLAN engineering testing software installed on the EUT can provide continuous transmitting RF signal.



## **4. Specific Absorption Rate (SAR)**

### **4.1 Introduction**

SAR is related to the rate at which energy is absorbed per unit mass in an object exposed to a radio field. The SAR distribution in a biological body is complicated and is usually carried out by experimental techniques or numerical modeling. The standard recommends limits for two tiers of groups, occupational/controlled and general population/uncontrolled, based on a person's awareness and ability to exercise control over his or her exposure. In general, occupational/controlled exposure limits are higher than the limits for general population/uncontrolled.

### **4.2 SAR Definition**

The SAR definition is the time derivative (rate) of the incremental energy (dW) absorbed by (dissipated in) an incremental mass (dm) contained in a volume element (dv) of a given density ( $\rho$ ). The equation description is as below:

$$\text{SAR} = \frac{d}{dt} \left( \frac{dW}{dm} \right) = \frac{d}{dt} \left( \frac{dW}{\rho dv} \right)$$

SAR is expressed in units of Watts per kilogram (W/kg)

SAR measurement can be either related to the temperature elevation in tissue by

$$\text{SAR} = c \left( \frac{\delta T}{\delta t} \right)$$

Where: C is the specific heat capacity,  $\delta T$  is the temperature rise and  $\delta t$  is the exposure duration, or related to the electrical field in the tissue by

$$\text{SAR} = \frac{\sigma |E|^2}{\rho}$$

Where:  $\sigma$  is the conductivity of the tissue,  $\rho$  is the mass density of the tissue and E is the RMS electrical field strength.

However for evaluating SAR of low power transmitter, electrical field measurement is typically applied.

## 5. SAR Measurement System

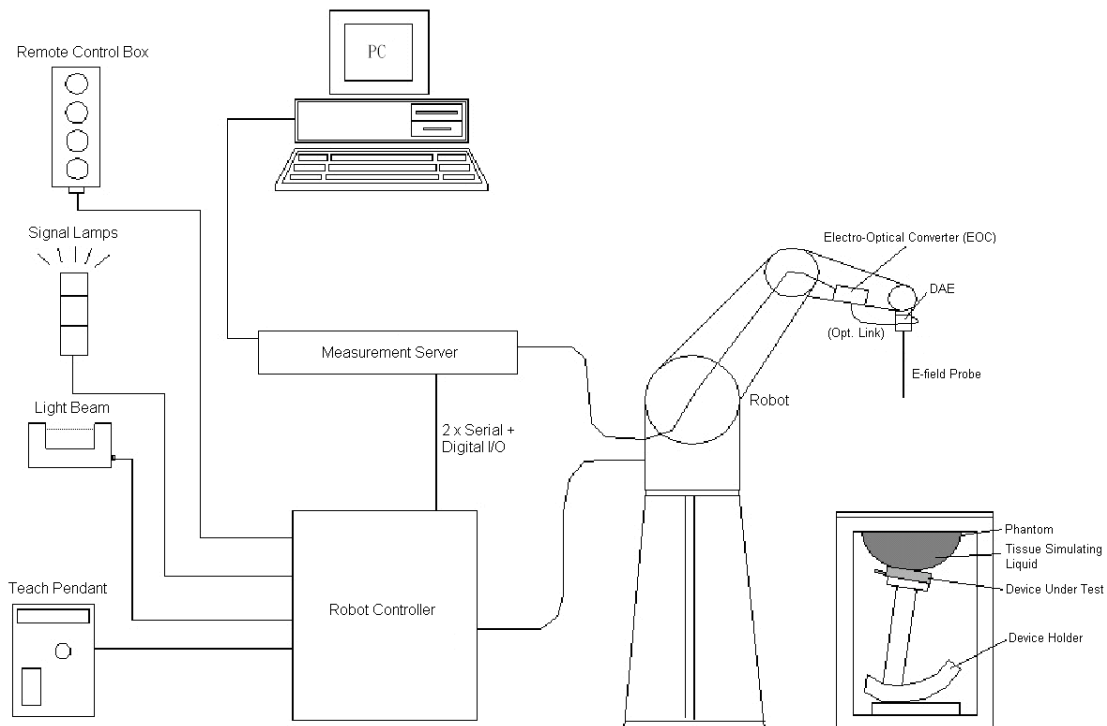

**Fig 5.1 SPEAG DASY System Configurations**

The DASY system for performance compliance tests is illustrated above graphically. This system consists of the following items:

- A standard high precision 6-axis robot with controller, a teach pendant and software
- A data acquisition electronic (DAE) attached to the robot arm extension
- A dosimetric probe equipped with an optical surface detector system
- The electro-optical converter (EOC) performs the conversion between optical and electrical signals
- A measurement server performs the time critical tasks such as signal filtering, control of the robot operation and fast movement interrupts.
- A probe alignment unit which improves the accuracy of the probe positioning
- A computer operating Windows XP
- DASY software
- Remote control with teach pendant and additional circuitry for robot safety such as warning lamps, etc.
- The SAM twin phantom
- A device holder
- Tissue simulating liquid
- Dipole for evaluating the proper functioning of the system

Component details are described in in the following sub-sections.

### 5.1 E-Field Probe

The SAR measurement is conducted with the dosimetric probe (manufactured by SPEAG). The probe is specially designed and calibrated for use in liquid with high permittivity. The dosimetric probe has special calibration in liquid at different frequency. This probe has a built in optical surface detection system to prevent from collision with phantom.

#### 5.1.1 E-Field Probe Specification

##### <EX3DV4 Probe>

<b>Construction</b>	Symmetrical design with triangular core Built-in shielding against static charges PEEK enclosure material (resistant to organic solvents, e.g., DGBE)	
<b>Frequency</b>	10 MHz to 6 GHz; Linearity: $\pm 0.2$ dB	
<b>Directivity</b>	$\pm 0.3$ dB in HSL (rotation around probe axis) $\pm 0.5$ dB in tissue material (rotation normal to probe axis)	
<b>Dynamic Range</b>	10 $\mu$ W/g to 100 mW/g; Linearity: $\pm 0.2$ dB (noise: typically $< 1$ $\mu$ W/g)	
<b>Dimensions</b>	Overall length: 330 mm (Tip: 20 mm) Tip diameter: 2.5 mm (Body: 12 mm) Typical distance from probe tip to dipole centers: 1 mm	

**Fig 5.2 Photo of EX3DV4**

#### 5.1.2 E-Field Probe Calibration

Each probe needs to be calibrated according to a dosimetric assessment procedure with accuracy better than  $\pm 10\%$ . The spherical isotropy shall be evaluated and within  $\pm 0.25$ dB. The sensitivity parameters (NormX, NormY, and NormZ), the diode compression parameter (DCP) and the conversion factor (ConvF) of the probe are tested. The calibration data can be referred to appendix C of this report.

### **5.2 Data Acquisition Electronics (DAE)**

The data acquisition electronics (DAE) consists of a highly sensitive electrometer-grade preamplifier with auto-zeroing, a channel and gain-switching multiplexer, a fast 16 bit AD-converter and a command decoder and control logic unit. Transmission to the measurement server is accomplished through an optical downlink for data and status information as well as an optical uplink for commands and the clock. The input impedance of the DAE is 200 MOhm; the inputs are symmetrical and floating. Common mode rejection is above 80 dB.

**Fig 5.3 Photo of DAE**

### **5.3 Robot**

The SPEAG DASY system uses the high precision robots (DASY5: TX90XL) type from Stäubli SA (France). For the 6-axis controller system, the robot controller version (DASY5: CS8c) from Stäubli is used. The Stäubli robot series have many features that are important for our application:

- High precision (repeatability  $\pm 0.035$  mm)
- High reliability (industrial design)
- Jerk-free straight movements
- Low ELF interference (the closed metallic construction shields against motor control fields)

**Fig 5.4 Photo of DASY5**

### **5.4 Measurement Server**

The measurement server is based on a PC/104 CPU board with CPU (DASY5: 400 MHz, Intel Celeron), chipdisk (DASY5: 128 MB), RAM (DASY5: 128 MB). The necessary circuits for communication with the DAE electronic box, as well as the 16 bit AD converter system for optical detection and digital I/O interface are contained on the DASY I/O board, which is directly connected to the PC/104 bus of the CPU board.

The measurement server performs all the real-time data evaluation for field measurements and surface detection, controls robot movements and handles safety operations.

**Fig 5.5 Photo of Server for DASY5**

### 5.5 Phantom

<SAM Twin Phantom>

Shell Thickness	2 ± 0.2 mm; Center ear point: 6 ± 0.2 mm
Filling Volume	Approx. 25 liters
Dimensions	Length: 1000 mm; Width: 500 mm; Height: adjustable feet
Measurement Areas	Left Hand, Right Hand, Flat Phantom



Fig 5.6 Photo of SAM Phantom

The bottom plate contains three pair of bolts for locking the device holder. The device holder positions are adjusted to the standard measurement positions in the three sections. A white cover is provided to tap the phantom during off-periods to prevent water evaporation and changes in the liquid parameters. On the phantom top, three reference markers are provided to identify the phantom position with respect to the robot.

### 5.6 Device Holder

<Device Holder for SAM Twin Phantom>

The SAR in the phantom is approximately inversely proportional to the square of the distance between the source and the liquid surface. For a source at 5 mm distance, a positioning uncertainty of ± 0.5 mm would produce a SAR uncertainty of ± 20 %. Accurate device positioning is therefore crucial for accurate and repeatable measurements. The positions in which the devices must be measured are defined by the standards.

The DASY device holder is designed to cope with different positions given in the standard. It has two scales for the device rotation (with respect to the body axis) and the device inclination (with respect to the line between the ear reference points). The rotation center for both scales is the ear reference point (ERP). Thus the device needs no repositioning when changing the angles.

The DASY device holder is constructed of low-loss POM material having the following dielectric parameters: relative permittivity  $\epsilon = 3$  and loss tangent  $\delta = 0.02$ . The amount of dielectric material has been reduced in the closest vicinity of the device, since measurements have suggested that the influence of the clamp on the test results could thus be lowered.



Fig 5.7 Device Holder

## 5.7 Data Storage and Evaluation

### 5.7.1 Data Storage

The DASY software stores the assessed data from the data acquisition electronics as raw data (in microvolt readings from the probe sensors), together with all the necessary software parameters for the data evaluation (probe calibration data, liquid parameters and device frequency and modulation data) in measurement files. The post-processing software evaluates the desired unit and format for output each time the data is visualized or exported. This allows verification of the complete software setup even after the measurement and allows correction of erroneous parameter settings. For example, if a measurement has been performed with an incorrect crest factor parameter in the device setup, the parameter can be corrected afterwards and the data can be reevaluated.

The measured data can be visualized or exported in different units or formats, depending on the selected probe type (e.g., [V/m], [A/m], [mW/g]). Some of these units are not available in certain situations or give meaningless results, e.g., a SAR-output in a non-lose media, will always be zero. Raw data can also be exported to perform the evaluation with other software packages.

### 5.7.2 Data Evaluation

The DASY post-processing software (SEMCAD) automatically executes the following procedures to calculate the field units from the microvolt readings at the probe connector. The parameters used in the evaluation are stored in the configuration modules of the software :

<b>Probe parameters :</b>	- Sensitivity	Norm <sub>i</sub> , a <sub>i0</sub> , a <sub>i1</sub> , a <sub>i2</sub>
	- Conversion factor	ConvF <sub>i</sub>
	- Diode compression point	dcp <sub>i</sub>
<b>Device parameters :</b>	- Frequency	f
	- Crest factor	cf
<b>Media parameters :</b>	- Conductivity	σ
	- Density	ρ

These parameters must be set correctly in the software. They can be found in the component documents or they can be imported into the software from the configuration files issued for the DASY components. In the direct measuring mode of the multi-meter option, the parameters of the actual system setup are used. In the scan visualization and export modes, the parameters stored in the corresponding document files are used.

The first step of the evaluation is a linearization of the filtered input signal to account for the compression characteristics of the detector diode. The compensation depends on the input signal, the diode type and the DC-transmission factor from the diode to the evaluation electronics. If the exciting field is pulsed, the crest factor of the signal must be known to correctly compensate for peak power.

The formula for each channel can be given as :

$$V_i = U_i + U_i^2 \cdot \frac{cf}{dcp_i}$$

with  $V_i$  = compensated signal of channel i, (i = x, y, z)  
 $U_i$  = input signal of channel i, (i = x, y, z)  
 cf = crest factor of exciting field (DASY parameter)  
 dcp<sub>i</sub> = diode compression point (DASY parameter)

From the compensated input signals, the primary field data for each channel can be evaluated :

$$\text{E-field Probes : } E_i = \sqrt{\frac{V_i}{\text{Norm}_i \cdot \text{ConvF}}}$$

$$\text{H-field Probes : } H_i = \sqrt{V_i \cdot \frac{a_{i0} + a_{i1}f + a_{i2}f^2}{f}}$$

with  $V_i$  = compensated signal of channel i, (i = x, y, z)  
 $\text{Norm}_i$  = sensor sensitivity of channel i, (i = x, y, z),  $\mu\text{V}/(\text{V/m})^2$  for E-field Probes  
 ConvF = sensitivity enhancement in solution  
 $a_{ij}$  = sensor sensitivity factors for H-field probes  
 f = carrier frequency [GHz]  
 $E_i$  = electric field strength of channel i in V/m  
 $H_i$  = magnetic field strength of channel i in A/m

The RSS value of the field components gives the total field strength (Hermitian magnitude) :

$$E_{\text{tot}} = \sqrt{E_x^2 + E_y^2 + E_z^2}$$

The primary field data are used to calculate the derived field units.

$$\text{SAR} = E_{\text{tot}}^2 \cdot \frac{\sigma}{\rho \cdot 1000}$$

with SAR = local specific absorption rate in mW/g  
 $E_{\text{tot}}$  = total field strength in V/m  
 $\sigma$  = conductivity in [mho/m] or [Siemens/m]  
 $\rho$  = equivalent tissue density in  $\text{g}/\text{cm}^3$

Note that the density is set to 1, to account for actual head tissue density rather than the density of the tissue simulating liquid.



**5.8 Test Equipment List**

Manufacturer	Name of Equipment	Type/Model	Serial Number	Calibration	
				Last Cal.	Due Date
SPEAG	835MHz System Validation Kit	D835V2	4d091	Nov. 18, 2011	Nov. 16, 2013
SPEAG	1900MHz System Validation Kit	D1900V2	5d118	Nov. 21, 2011	Nov. 16, 2013
SPEAG	2450MHz System Validation Kit	D2450V2	736	Jul. 25, 2011	Jul. 24, 2013
SPEAG	Data Acquisition Electronics	DAE4	1303	Nov. 22, 2012	Nov. 21, 2013
SPEAG	Dosimetric E-Field Probe	EX3DV4	3819	Nov. 26, 2012	Nov. 25, 2013
SPEAG	SAM Twin Phantom	QD 000 P40 CD	TP-1670	NCR	NCR
SPEAG	SAM Twin Phantom	QD 000 P40 CD	TP-1671	NCR	NCR
SPEAG	Test Arch Phantom	Par phantom	1105	NCR	NCR
SPEAG	Phone Positioner	N/A	N/A	NCR	NCR
Anritsu	Radio Communication Analyzer	MT8820C	6201091028	Jun. 10, 2012	Jun. 09, 2013
Agilent	Base Station	E5515C	MY50267224	Dec. 29, 2012	Dec. 28, 2013
Agilent	ENA Series Network Analyzer	E5071C	MY46111157	Apr. 13, 2012	Apr. 12, 2013
Anritsu	Power Meter	ML2495A	1218010	May 07, 2012	May 06, 2013
Anritsu	Power Sensor	MA2411B	1207253	May 08, 2012	May 07, 2013
Agilent	Dual Directional Coupler	778D	50422	Note 4	
Woken	Attenuator 1	WK0602-XX	N/A	Note 4	
PE	Attenuator 2	PE7005-10	N/A	Note 4	
PE	Attenuator 3	PE7005-3	N/A	Note 4	
Agilent	Dielectric Probe Kit	85070D	US01440205	Note 5	
AR	Power Amplifier	5S1G4M2	0328767	Note 6	
R&S	Spectrum Analyzer	FSP30	101400	Jun. 01, 2012	May 31, 2013

**Table 5.1 Test Equipment List**

**Note:**

1. The calibration certificate of DASY can be referred to appendix C of this report.
2. Referring to KDB 865664 D01v01, the dipole calibration interval can be extended to 3 years with justification. The dipoles are also not physically damaged, or repaired during the interval.
3. The justification data of dipole D835V2, SN: 4d091, D1900V2, SN: 5d118, D2450V2, SN: 736, can be found in appendix C. The return loss is < -20dB, within 20% of prior calibration, the impedance is within 5 ohm of prior calibration.
4. The Insertion Loss calibration of Dual Directional Coupler and Attenuator were characterized via the network analyzer and compensated during system check.
5. The dielectric probe kit was calibrated via the network analyzer, with the specified procedure (calibrated in pure water) and calibration kit (standard) short circuit, before the dielectric measurement. The specific procedure and calibration kit are provided by Agilent.
6. In system check we need to monitor the level on the power meter, and adjust the power amplifier level to have precise power level to the dipole; the measured SAR will be normalized to 1W input power according to the ratio of 1W to the input power to the dipole. For system check, the calibration of the power amplifier is deemed not critically required for correct measurement; the power meter is critical and we do have calibration for it
7. Attenuator 1 insertion loss is calibrated by the network Analyzer, which the calibration is valid, before system check.



## 6. Tissue Simulating Liquids

For the measurement of the field distribution inside the SAM phantom with DASY, the phantom must be filled with around 25 liters of homogeneous body tissue simulating liquid. For head SAR testing, the liquid height from the ear reference point (ERP) of the phantom to the liquid top surface is larger than 15 cm, which is shown in Fig. 6.1. For body SAR testing, the liquid height from the center of the flat phantom to the liquid top surface is larger than 15 cm, which is shown in Fig. 6.2.



Fig 6.1 Photo of Liquid Height for Head SAR



Fig 6.2 Photo of Liquid Height for Body SAR

The following table gives the recipes for tissue simulating liquid.

Frequency (MHz)	Water (%)	Sugar (%)	Cellulose (%)	Salt (%)	Preventol (%)	DGBE (%)	Conductivity ( $\sigma$ )	Permittivity ( $\epsilon_r$ )
<b>For Head</b>								
835	40.3	57.9	0.2	1.4	0.2	0	0.90	41.5
1800, 1900, 2000	55.2	0	0	0.3	0	44.5	1.40	40.0
2450	55.0	0	0	0	0	45.0	1.80	39.2
<b>For Body</b>								
835	50.8	48.2	0	0.9	0.1	0	0.97	55.2
1800, 1900, 2000	70.2	0	0	0.4	0	29.4	1.52	53.3
2450	68.6	0	0	0	0	31.4	1.95	52.7

Table 6.1 Recipes of Tissue Simulating Liquid

The dielectric parameters of the liquids were verified prior to the SAR evaluation using an Agilent 85070D Dielectric Probe Kit and an Agilent Network Analyzer.

The following table shows the measuring results for simulating liquid.

Freq. (MHz)	Liquid Type	Temp. (°C)	Conductivity ( $\sigma$ )	Permittivity ( $\epsilon_r$ )	Conductivity Target ( $\sigma$ )	Permittivity Target ( $\epsilon_r$ )	Delta ( $\sigma$ ) (%)	Delta ( $\epsilon_r$ ) (%)	Limit (%)	Date
835	Head	21.3	0.901	40.589	0.90	41.5	0.11	-2.20	±5	Feb. 20, 2013
1900	Head	21.8	1.435	38.464	1.40	40.0	2.50	-3.84	±5	Feb. 17, 2013
2450	Head	21.4	1.856	37.685	1.80	39.2	3.11	-3.86	±5	Feb. 28, 2013
835	Body	21.2	0.969	56.069	0.97	55.2	-0.10	1.57	±5	Feb. 19, 2013
1900	Body	21.5	1.528	54.867	1.52	53.3	0.53	2.94	±5	Feb. 16, 2013
2450	Body	21.1	1.951	53.859	1.95	52.7	0.05	2.20	±5	Feb. 28, 2013

Table 6.2 Measuring Results for Simulating Liquid

## 7. SAR System Verification

Each DASY system is equipped with one or more system validation kits. These units, together with the predefined measurement procedures within the DASY software, enable the user to conduct the system performance check and system validation. System validation kit includes a dipole, tripod holder to fix it underneath the flat phantom and a corresponding distance holder.

### 7.1 Purpose of System Performance check

The system performance check verifies that the system operates within its specifications. System and operator errors can be detected and corrected. It is recommended that the system performance check be performed prior to any usage of the system in order to guarantee reproducible results. The system performance check uses normal SAR measurements in a simplified setup with a well characterized source. This setup was selected to give a high sensitivity to all parameters that might fail or vary over time. The system check does not intend to replace the calibration of the components, but indicates situations where the system uncertainty is exceeded due to drift or failure.

### 7.2 System Setup

In the simplified setup for system evaluation, the EUT is replaced by a calibrated dipole and the power source is replaced by a continuous wave that comes from a signal generator. The calibrated dipole must be placed beneath the flat phantom section of the SAM twin phantom with the correct distance holder. The distance holder should touch the phantom surface with a light pressure at the reference marking and be oriented parallel to the long side of the phantom. The equipment setup is shown below:

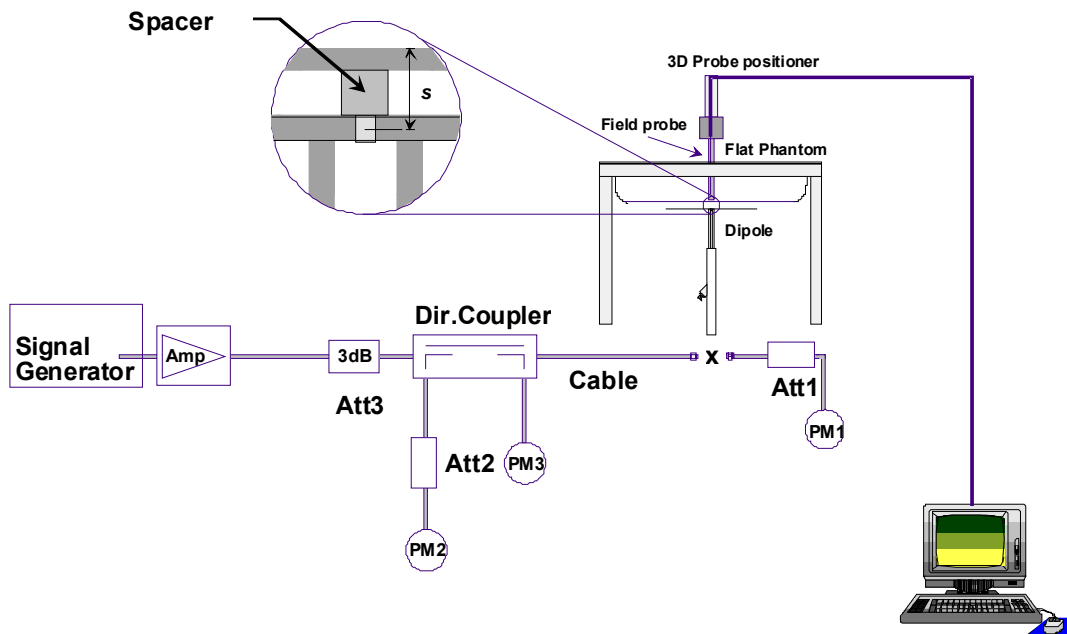

Fig 7.1 System Setup for System Evaluation

1. Signal Generator
2. Amplifier
3. Directional Coupler
4. Power Meter
5. Calibrated Dipole



**Fig 7.2 Photo of Dipole Setup**

**7.3 SAR System Verification Results**

Comparing to the original SAR value provided by SPEAG, the verification data should be within its specification of 10 %. Table 7.1 shows the target SAR and measured SAR after normalized to 1W input power. The table below indicates the system performance check can meet the variation criterion and the plots can be referred to Appendix A of this report.

Measurement Date	Frequency (MHz)	Liquid Type	Power fed onto reference dipole (mW)	Targeted SAR <sub>1g</sub> (W/kg)	Measured SAR <sub>1g</sub> (W/kg)	Normalized SAR <sub>1g</sub> (W/kg)	Deviation (%)
Feb. 20, 2013	835	Head	250	9.40	2.47	9.88	5.11
Feb. 17, 2013	1900	Head	250	40.3	10.2	40.8	1.24
Feb. 28, 2013	2450	Head	250	54.8	14.2	56.8	3.65
Feb. 19, 2013	835	Body	250	9.42	2.41	9.64	2.34
Feb. 16, 2013	1900	Body	250	41.8	10.3	41.2	-1.44
Feb. 28, 2013	2450	Body	250	52.3	13.4	53.6	2.49

**Table 7.1 Target and Measurement SAR after Normalized**

## 8. EUT Testing Position

This EUT was tested in ten different positions. They are right cheek, right tilted, left cheek, left tilted, Front of the EUT with phantom 1 cm gap, Back of the EUT with phantom 1 cm gap, Top Side of the EUT with phantom 1 cm gap, Bottom Side of the EUT with phantom 1 cm gap, Right Side of the EUT with phantom 1 cm gap, and Left Side of the EUT with phantom 1 cm gap, as illustrated below.

### 8.1 Define two imaginary lines on the handset

- The vertical centerline passes through two points on the front side of the handset - the midpoint of the width  $w_t$  of the handset at the level of the acoustic output, and the midpoint of the width  $w_b$  of the bottom of the handset.
- The horizontal line is perpendicular to the vertical centerline and passes through the center of the acoustic output. The horizontal line is also tangential to the face of the handset at point A.
- The two lines intersect at point A. Note that for many handsets, point A coincides with the center of the acoustic output; however, the acoustic output may be located elsewhere on the horizontal line. Also note that the vertical centerline is not necessarily parallel to the front face of the handset, especially for clamshell handsets, handsets with flip covers, and other irregularly shaped handsets.

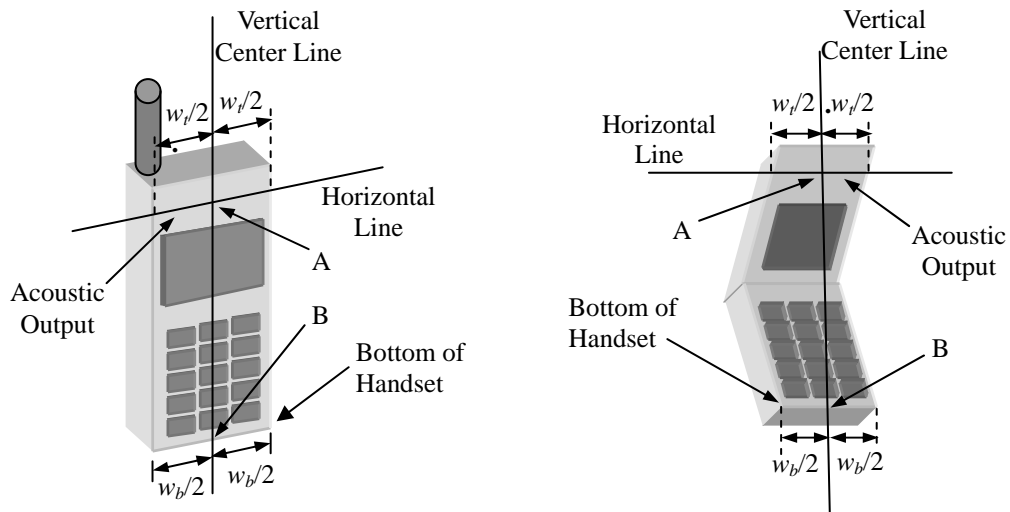

Fig 8.1 Illustration for Handset Vertical and Horizontal Reference Lines

### 8.2 Cheek Position

- (a) To position the device with the vertical center line of the body of the device and the horizontal line crossing the center piece in a plane parallel to the sagittal plane of the phantom. While maintaining the device in this plane, align the vertical center line with the reference plane containing the three ear and mouth reference point (M: Mouth, RE: Right Ear, and LE: Left Ear) and align the center of the ear piece with the line RE-LE.
- (b) To move the device towards the phantom with the ear piece aligned with the line LE-RE until the phone touched the ear. While maintaining the device in the reference plane and maintaining the phone contact with the ear, move the bottom of the phone until any point on the front side is in contact with the cheek of the phantom or until contact with the ear is lost (see Fig. 8.2).

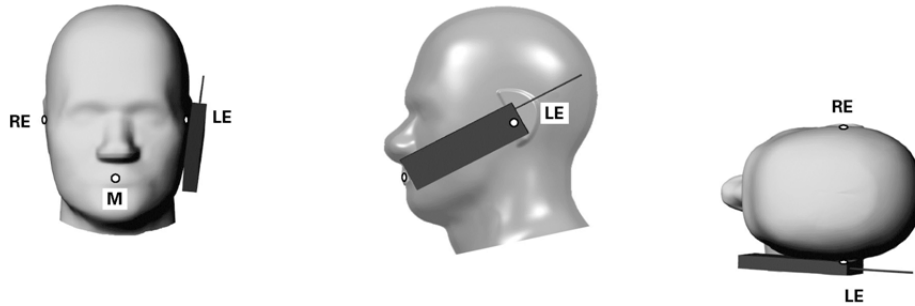

Fig 8.2 Illustration for Cheek Position

### 8.3 Tilted Position

- (a) To position the device in the “cheek” position described above.
- (b) While maintaining the device the reference plane described above and pivoting against the ear, moves it outward away from the mouth by an angle of 15 degrees or until contact with the ear is lost (see Fig. 8.3).

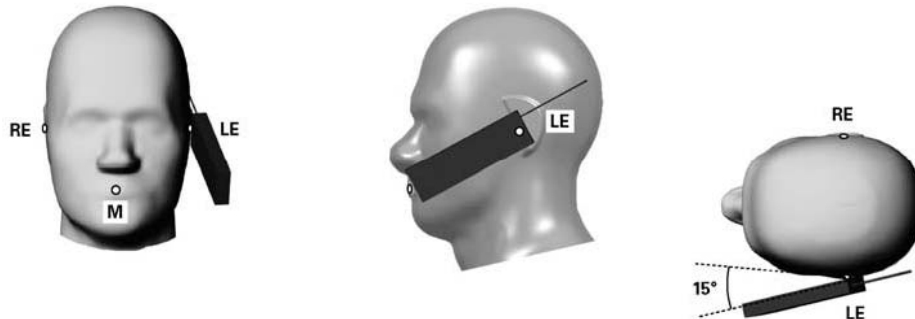
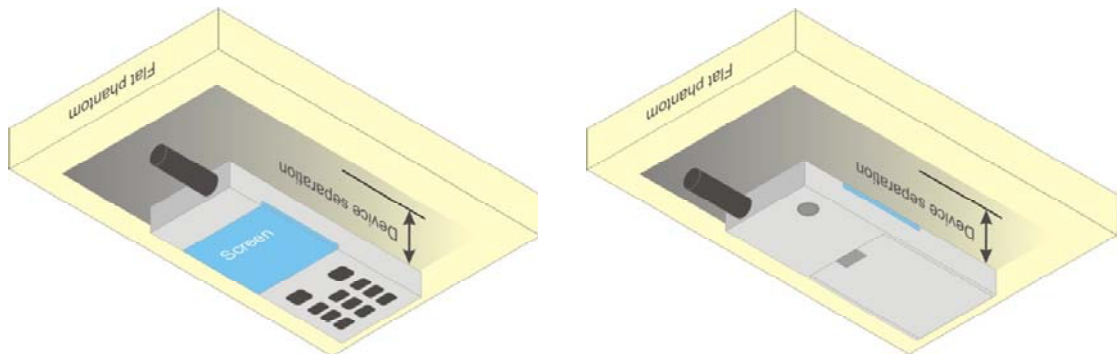

Fig 8.3 Illustration for Tilted Position

### **8.4 Body Worn Position**

- (a) To position the device parallel to the phantom surface with either keypad up or down.
- (b) To adjust the device parallel to the flat phantom.
- (c) To adjust the distance between the device surface and the flat phantom to 1 cm.



**Fig 8.4 Illustration for Body Worn Position**

### **8.5 Hotspot Position**

- (a) To position the device parallel to the phantom surface with all sides.
- (b) To adjust the device parallel to the flat phantom.
- (c) To adjust the distance between the device and the flat phantom to 1 cm.

#### **<EUT Setup Photos>**

Please refer to Appendix E for the test setup photos.

## 9. Measurement Procedures

The measurement procedures are as follows:

### <Conducted power measurement>

- (a) For WWAN power measurement, use base station simulator to configure EUT WWAN transmission in conducted connection with RF cable, at maximum power in each supported wireless interface and frequency band.
- (b) Read the WWAN RF power level from the base station simulator.
- (c) For WLAN/BT power measurement, use engineering software to configure EUT WLAN/BT continuously transmission, at maximum RF power in each supported wireless interface and frequency band
- (d) Connect EUT RF port through RF cable to the power meter, and measure WLAN/BT output power

### <SAR measurement>

- (a) Use base station simulator to configure EUT WWAN transmission in radiated connection, and engineering software to configure EUT WLAN/BT continuously transmission, at maximum RF power, in the highest power channel.
- (b) Place the EUT in the positions as Appendix E demonstrates.
- (c) Set scan area, grid size and other setting on the DASY software.
- (d) Measure SAR results for the highest power channel on each testing position.
- (e) Find out the largest SAR result on these testing positions of each band
- (f) Measure SAR results for other channels in worst SAR testing position if the reported SAR of highest power channel is larger than 0.8 W/kg

According to the test standard, the recommended procedure for assessing the peak spatial-average SAR value consists of the following steps:

- (a) Power reference measurement
- (b) Area scan
- (c) Zoom scan
- (d) Power drift measurement

### 9.1 Spatial Peak SAR Evaluation

The procedure for spatial peak SAR evaluation has been implemented according to the test standard. It can be conducted for 1g and 10g, as well as for user-specific masses. The DASY software includes all numerical procedures necessary to evaluate the spatial peak SAR value.

The base for the evaluation is a "cube" measurement. The measured volume must include the 1g and 10g cubes with the highest averaged SAR values. For that purpose, the center of the measured volume is aligned to the interpolated peak SAR value of a previously performed area scan.

The entire evaluation of the spatial peak values is performed within the post-processing engine (SEMCAD). The system always gives the maximum values for the 1g and 10g cubes. The algorithm to find the cube with highest averaged SAR is divided into the following stages:

- (a) Extraction of the measured data (grid and values) from the Zoom Scan
- (b) Calculation of the SAR value at every measurement point based on all stored data (A/D values and measurement parameters)
- (c) Generation of a high-resolution mesh within the measured volume
- (d) Interpolation of all measured values from the measurement grid to the high-resolution grid
- (e) Extrapolation of the entire 3-D field distribution to the phantom surface over the distance from sensor to surface
- (f) Calculation of the averaged SAR within masses of 1g and 10g



### 9.2 Power Reference Measurement

The Power Reference Measurement and Power Drift Measurements are for monitoring the power drift of the device under test in the batch process. The minimum distance of probe sensors to surface determines the closest measurement point to phantom surface. This distance cannot be smaller than the distance of sensor calibration points to probe tip as defined in the probe properties.

### 9.3 Area & Zoom Scan Procedures

First Area Scan is used to locate the approximate location(s) of the local peak SAR value(s). The measurement grid within an Area Scan is defined by the grid extent, grid step size and grid offset. Next, in order to determine the EM field distribution in a three-dimensional spatial extension, Zoom Scan is required. The Zoom Scan is performed around the highest E-field value to determine the averaged SAR-distribution over 10 g. Area scan and zoom scan resolution setting follows KDB 865664 D01v01 quoted below.

For any secondary peaks found in the area scan which are within 2 dB of the maximum peak and are not within this zoom scan, the zoom scan should be repeated

		≤ 3 GHz	> 3 GHz
Maximum distance from closest measurement point (geometric center of probe sensors) to phantom surface		5 ± 1 mm	½·δ·ln(2) ± 0.5 mm
Maximum probe angle from probe axis to phantom surface normal at the measurement location		30° ± 1°	20° ± 1°
Maximum area scan spatial resolution: Δx <sub>Area</sub> , Δy <sub>Area</sub>		≤ 2 GHz: ≤ 15 mm 2 – 3 GHz: ≤ 12 mm	3 – 4 GHz: ≤ 12 mm 4 – 6 GHz: ≤ 10 mm
		When the x or y dimension of the test device, in the measurement plane orientation, is smaller than the above, the measurement resolution must be ≤ the corresponding x or y dimension of the test device with at least one measurement point on the test device.	
Maximum zoom scan spatial resolution: Δx <sub>Zoom</sub> , Δy <sub>Zoom</sub>		≤ 2 GHz: ≤ 8 mm 2 – 3 GHz: ≤ 5 mm*	3 – 4 GHz: ≤ 5 mm* 4 – 6 GHz: ≤ 4 mm*
Maximum zoom scan spatial resolution, normal to phantom surface	uniform grid: Δz <sub>Zoom</sub> (n)	≤ 5 mm	3 – 4 GHz: ≤ 4 mm 4 – 5 GHz: ≤ 3 mm 5 – 6 GHz: ≤ 2 mm
	graded grid Δz <sub>Zoom</sub> (1): between 1 <sup>st</sup> two points closest to phantom surface	≤ 4 mm	3 – 4 GHz: ≤ 3 mm 4 – 5 GHz: ≤ 2.5 mm 5 – 6 GHz: ≤ 2 mm
	Δz <sub>Zoom</sub> (n>1): between subsequent points	≤ 1.5·Δz <sub>Zoom</sub> (n-1)	
Minimum zoom scan volume	x, y, z	≥ 30 mm	3 – 4 GHz: ≥ 28 mm 4 – 5 GHz: ≥ 25 mm 5 – 6 GHz: ≥ 22 mm
<p>Note: δ is the penetration depth of a plane-wave at normal incidence to the tissue medium; see draft standard IEEE P1528-2011 for details.</p> <p>* When zoom scan is required and the <i>reported</i> SAR from the area scan based <i>1-g SAR estimation</i> procedures of KDB 447498 is ≤ 1.4 W/kg, ≤ 8 mm, ≤ 7 mm and ≤ 5 mm zoom scan resolution may be applied, respectively, for 2 GHz to 3 GHz, 3 GHz to 4 GHz and 4 GHz to 6 GHz.</p>			





### **9.4 Volume Scan Procedures**

The volume scan is used for assess overlapping SAR distributions for antennas transmitting in different frequency bands. It is equivalent to an oversized zoom scan used in standalone measurements. The measurement volume will be used to enclose all the simultaneous transmitting antennas. For antennas transmitting simultaneously in different frequency bands, the volume scan is measured separately in each frequency band. In order to sum correctly to compute the 1g aggregate SAR, the EUT remain in the same test position for all measurements and all volume scan use the same spatial resolution and grid spacing. When all volume scan were completed, the software, SEMCAD postprocessor can combine and subsequently superpose these measurement data to calculating the multiband SAR.

### **9.5 SAR Averaged Methods**

In DASYS, the interpolation and extrapolation are both based on the modified Quadratic Shepard's method. The interpolation scheme combines a least-square fitted function method and a weighted average method which are the two basic types of computational interpolation and approximation.

Extrapolation routines are used to obtain SAR values between the lowest measurement points and the inner phantom surface. The extrapolation distance is determined by the surface detection distance and the probe sensor offset. The uncertainty increases with the extrapolation distance. To keep the uncertainty within 1% for the 1 g and 10 g cubes, the extrapolation distance should not be larger than 5 mm.

### **9.6 Power Drift Monitoring**

All SAR testing is under the EUT install full charged battery and transmit maximum output power. In DASYS measurement software, the power reference measurement and power drift measurement procedures are used for monitoring the power drift of EUT during SAR test. Both these procedures measure the field at a specified reference position before and after the SAR testing. The software will calculate the field difference in dB. If the power drifts more than 5%, the SAR will be retested.

### 10. Conducted RF Output Power (Unit: dBm)

<CDMA2000 Conducted Power>

Note:

1. According to KDB 941225 D01, Head SAR for RC1+SO55 is not required because the maximum average output power of RC1 is less than 1/4 dB higher than RC3+SO55.
2. Referring to KDB 941225 D01, the CDMA Handset Body-worn SAR tests based on RC3+SO32. RC1, Ev-Do Rev 0 (RTAP 153.6kbps) Ev-Do Rev A(RETAP 4096 bits) power are all less than 1/4 dB higher than RC3, thus SAR testing in these modes are not required.
3. Referring to KDB 941225 D01, in Hotspot mode EUT is treated as data device and SAR is tested with Ev-Do Rev 0 (RTAP 153.6kbps). If 1xRTT and Ev-Do Rev A(RETAP 4096 bits) power is less than 1/4dB higher than Re v0, SAR tests with those settings are not necessary.

Band	CDMA2000 BC0			CDMA2000 BC1		
	Channel	1013	384	777	25	600
Frequency (MHz)	824.70	836.52	848.31	1851.25	1880.00	1908.75
1xRTT RC1+SO55	21.64	21.93	21.71	23.57	23.46	23.51
1xRTT RC3+SO55	21.70	21.94	21.73	23.58	23.48	23.45
1xRTT RC3+SO32 (+ F-SCH)	21.67	21.85	21.72	23.57	23.47	23.47
1xRTT RC3 SO32(+SCH)	21.62	21.82	21.71	23.56	23.47	23.46
1xEVDO RTAP 153.6	21.67	21.87	21.72	23.52	23.43	23.45
1xEVDO RETAP 4096	21.65	21.84	21.72	23.51	23.40	23.45

<WLAN 2.4GHz Conducted Power>

WLAN 2.4GHz 802.11b Average Power (dBm)					
Channel	Frequency (MHz)	Data Rate (bps)			
		1M	2M	5.5M	11M
CH 01	2412	11.36	11.37	11.38	11.39
CH 06	2437	11.41	11.43	11.47	11.46
CH 11	2462	11.61	11.62	11.67	11.65

WLAN 2.4GHz 802.11g Average Power (dBm)									
Channel	Frequency (MHz)	Data Rate (bps)							
		6M	9M	12M	18M	24M	36M	48M	54M
CH 01	2412	8.49	8.51	8.52	8.58	8.93	8.94	9.43	9.42
CH 06	2437	9.29	9.31	9.32	9.38	9.18	9.18	9.19	9.15
CH 11	2462	9.56	9.58	9.57	9.65	9.43	9.46	9.48	9.43

WLAN 2.4GHz 802.11n-HT20 Average Power (dBm)									
Channel	Frequency (MHz)	MCS Index							
		MCS0	MCS1	MCS2	MCS3	MCS4	MCS5	MCS6	MCS7
CH 01	2412	8.45	8.43	8.49	9.43	9.42	9.47	9.48	9.46
CH 06	2437	9.23	9.24	9.31	9.19	9.19	9.23	9.24	9.19
CH 11	2462	9.50	9.51	9.57	9.42	9.41	9.46	9.46	9.40

Note:

1. Per KDB 248227 D01 v01r02, choose the highest output power channel to test SAR and determine further SAR exclusion
2. For each frequency band, testing at higher data rates and higher order modulations is not required when the maximum average output power for each of these configurations is less than 1/4dB higher than those measured at the lowest data rate
3. Per KDB 248227 D01 v01r02, 11g and 11n-HT20 output power is less than 1/4dB higher than 11b mode, thus the SAR can be excluded.



<Bluetooth Conducted Power>

		Bluetooth Average Power (dBm)								
Channel	Frequency (MHz)	Data Rate								
		DH1	DH3	DH5	2DH1	2DH3	2DH5	3DH1	3DH3	3DH5
CH 00	2402	-3.85	-3.88	-4.53	-4.01	-4.69	-4.91	-3.97	-4.70	-4.96
CH 39	2441	-3.23	-3.71	-3.84	-3.46	-4.09	-4.33	-3.44	-4.08	-4.28
CH 78	2480	-3.85	-3.83	-4.53	-4.01	-4.72	-4.89	-3.97	-4.68	-4.85

## 11. SAR Test Configurations

### 11.1 Exposure Positions Consideration

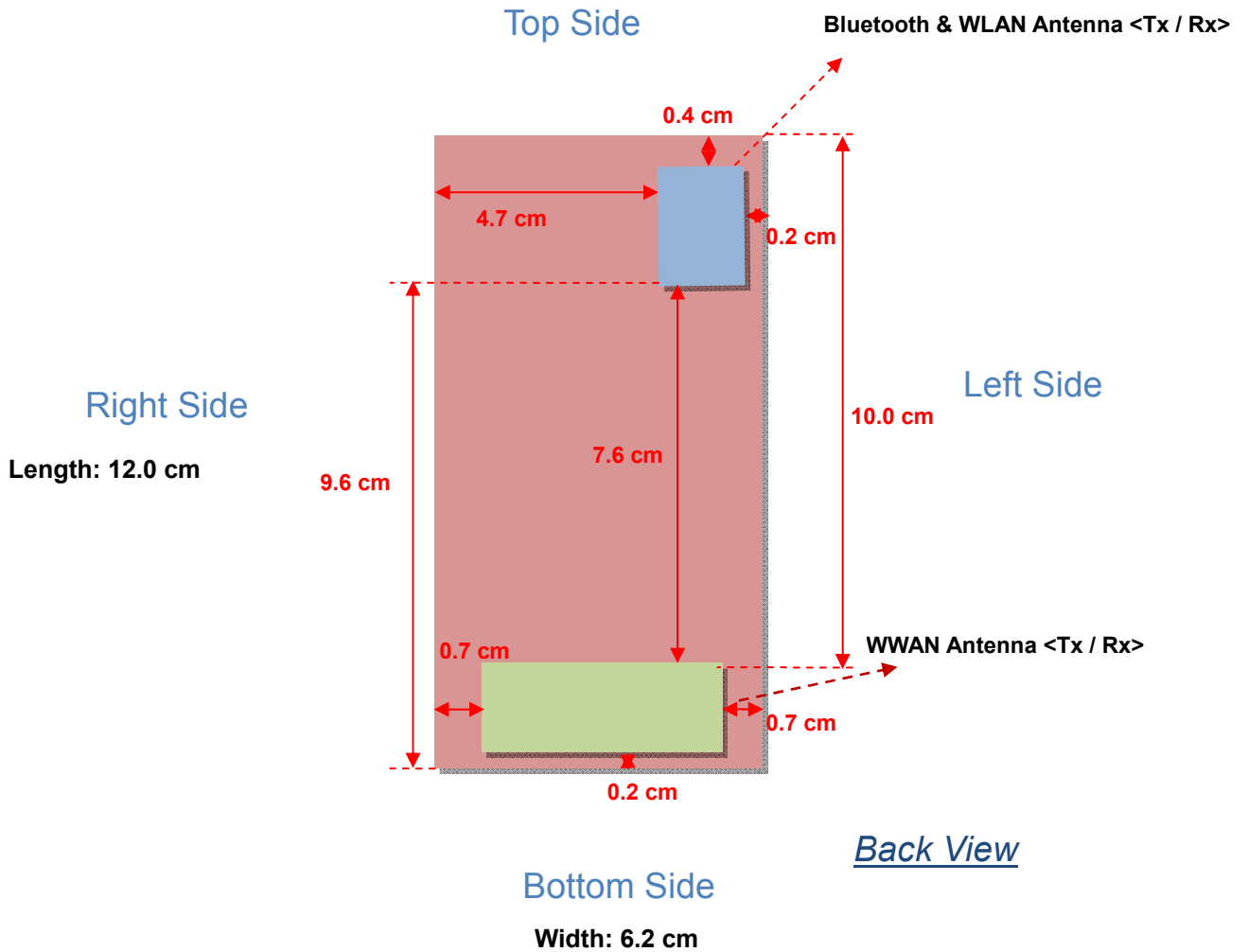

Antennas	Wireless Interface
WWAN Antenna (Tx / Rx)	CDMA2000 BC 0 CDMA2000 BC 1
Bluetooth & WLAN Antenna (Tx / Rx)	WLAN 2.4GHz Bluetooth

Distance of the Antenna to the EUT surface/edge Test distance: 10 mm						
Antennas	Back	Front	Top Side	Bottom Side	Right Side	Left Side
WWAN	≤ 25mm	≤ 25mm	100 mm	≤ 25mm	≤ 25mm	≤ 25mm
Bluetooth & WLAN	≤ 25mm	≤ 25mm	≤ 25mm	96 mm	47 mm	≤ 25mm

Sides for SAR tests; Hotspot mode Test distance: 10 mm						
Antennas	Back	Front	Top Side	Bottom Side	Right Side	Left Side
WWAN	YES	YES	NO	YES	YES	YES
Bluetooth & WLAN	YES	YES	YES	NO	NO	YES

**Note:**

- i. Head/Body-worn/Hotspot mode SAR assessments are required.
- ii. Referring to KDB 941225 D06, when the overall device length and width are ≥ 9cm\*5cm, the test distance is 10 mm. SAR must be measured for all sides and surfaces with a transmitting antenna located within 25mm from that surface or edge.
- iii. Per KDB 447498 D01v05, for handsets the test separation distance is determined by the smallest distance between the outer surface of the device and the user; which is 0mm for head SAR, 10mm for hotspot SAR, and 10mm for body-worn SAR.
- iv. If the test separation distance (antenna-user) is < 5mm, 5mm is used for estimated SAR calculation.
- v. For minimum test separation distance ≤50mm, Bluetooth standalone SAR is excluded according to  $[(max. power of channel, including tune-up tolerance, mW)/(min. test separation distance, mm)] \cdot [\sqrt{f(GHz)}] \leq 3.0$  for 1-g SAR and ≤ 7.5 for 10-g extremity SAR.

	Wireless Interface	Bluetooth
	Tune-up Maximum power (dBm)	-3
	Tune-up Maximum rated power (mW)	0.5
Head	Antenna to user (mm)	5
	SAR exclusion threshold (mW)	10
	SAR testing required?	<b>NO</b>
Body	Antenna to user (mm)	10
	SAR exclusion threshold (mW)	19
	SAR testing required?	<b>NO</b>



## 12. SAR Test Results

**Note:**

- Per KDB 447498 D01v05, the reported SAR is the measured SAR value adjusted for maximum tune-up tolerance.  
 $Scaling\ Factor = \frac{tune-up\ limit\ power\ (mW)}{EUT\ RF\ power\ (mW)}$ , where tune-up limit is the maximum rated power among all production units.  
 $Reported\ SAR(W/kg) = Measured\ SAR(W/kg) * Scaling\ Factor$
- Per KDB 447498 D01v05, for each exposure position, if the highest output channel reported SAR  $\leq 0.8W/kg$ , other channels SAR testing are not necessary

### 12.1 Test Records for Head SAR Test

**<CDMA2000>**

Plot No.	Band	Mode	Test Position	Ch.	Freq. (MHz)	Average Power (dBm)	Tune-Up Limit (dBm)	Scaling Factor	Power Drift (dB)	SAR <sub>1g</sub> (W/kg)	Reported SAR <sub>1g</sub> (W/kg)
54	CDMA2000 BC0	RC3 SO55	Right Cheek	384	836.52	21.94	23	1.276	-0.03	0.684	0.873
55	CDMA2000 BC0	RC3 SO55	Right Tilted	384	836.52	21.94	23	1.276	0.10	0.415	0.530
56	CDMA2000 BC0	RC3 SO55	Left Cheek	384	836.52	21.94	23	1.276	-0.08	0.705	0.900
57	CDMA2000 BC0	RC3 SO55	Left Tilted	384	836.52	21.94	23	1.276	0.05	0.431	0.550
58	CDMA2000 BC0	RC3 SO55	Right Cheek	1013	824.7	21.7	23	1.349	-0.01	0.548	0.739
59	CDMA2000 BC0	RC3 SO55	Right Cheek	777	848.31	21.73	23	1.340	-0.02	0.756	1.013
60	CDMA2000 BC0	RC3 SO55	Left Cheek	1013	824.7	21.7	23	1.349	0.04	0.535	0.722
<b>61</b>	<b>CDMA2000 BC0</b>	<b>RC3 SO55</b>	<b>Left Cheek</b>	<b>777</b>	<b>848.31</b>	<b>21.73</b>	<b>23</b>	<b>1.340</b>	<b>-0.02</b>	<b>0.763</b>	<b>1.022</b>
22	CDMA2000 BC1	RC3 SO55	Right Cheek	25	1851.25	23.58	24	1.102	0.14	0.840	0.925
23	CDMA2000 BC1	RC3 SO55	Right Tilted	25	1851.25	23.58	24	1.102	0.03	0.518	0.571
24	CDMA2000 BC1	RC3 SO55	Left Cheek	25	1851.25	23.58	24	1.102	-0.08	1.250	1.377
25	CDMA2000 BC1	RC3 SO55	Left Tilted	25	1851.25	23.58	24	1.102	-0.09	0.442	0.487
26	CDMA2000 BC1	RC3 SO55	Right Cheek	600	1880	23.48	24	1.127	-0.02	0.837	0.943
27	CDMA2000 BC1	RC3 SO55	Right Cheek	1175	1908.75	23.45	24	1.135	0.04	0.728	0.826
<b>28</b>	<b>CDMA2000 BC1</b>	<b>RC3 SO55</b>	<b>Left Cheek</b>	<b>600</b>	<b>1880</b>	<b>23.48</b>	<b>24</b>	<b>1.127</b>	<b>-0.03</b>	<b>1.330</b>	<b>1.499</b>
29	CDMA2000 BC1	RC3 SO55	Left Cheek	1175	1908.75	23.45	24	1.135	-0.02	1.150	1.305

**< WLAN 2.4GHz >**

Plot No.	Band	Mode	Test Position	Ch.	Freq. (MHz)	Average Power (dBm)	Tune-Up Limit (dBm)	Scaling Factor	Power Drift (dB)	SAR <sub>1g</sub> (W/kg)	Reported SAR <sub>1g</sub> (W/kg)
<b>62</b>	<b>WLAN2.4G</b>	<b>802.11b</b>	<b>Right Cheek</b>	<b>11</b>	<b>2462</b>	<b>11.61</b>	<b>12</b>	<b>1.094</b>	<b>0.11</b>	<b>0.114</b>	<b>0.125</b>
63	WLAN2.4G	802.11b	Right Tilted	11	2462	11.61	12	1.094	-0.09	0.060	0.066
64	WLAN2.4G	802.11b	Left Cheek	11	2462	11.61	12	1.094	0.07	0.055	0.060
65	WLAN2.4G	802.11b	Left Tilted	11	2462	11.61	12	1.094	-0.10	0.048	0.053

**12.2 Test Records for Hotspot SAR Test**

**Note:** For Hotspot SAR testing, per KDB 941225 D06, for EUT dimension  $\geq 9\text{cm} \times 5\text{cm}$ , the test distance is 1cm. SAR must be measured for all surfaces and sides with a transmitting antenna located within 2.5cm from that surface or edge.  
**< CDMA2000>**

Plot No.	Band	Mode	Test Position	Gap (cm)	Ch.	Freq. (MHz)	Average Power (dBm)	Tune-Up Limit (dBm)	Scaling Factor	Power Drift (dB)	SAR <sub>1g</sub> (W/kg)	Reported SAR <sub>1g</sub> (W/kg)
31	CDMA2000 BC0	RTAP 153.6	Front	1	384	836.52	21.87	23	1.297	-0.01	0.861	1.117
32	CDMA2000 BC0	RTAP 153.6	Back	1	384	836.52	21.87	23	1.297	-0.06	0.869	1.127
33	CDMA2000 BC0	RTAP 153.6	Left Side	1	384	836.52	21.87	23	1.297	-0.01	0.759	0.985
34	CDMA2000 BC0	RTAP 153.6	Right Side	1	384	836.52	21.87	23	1.297	-0.02	0.650	0.843
35	CDMA2000 BC0	RTAP 153.6	Bottom Side	1	384	836.52	21.87	23	1.297	0.07	0.082	0.106
36	CDMA2000 BC0	RTAP 153.6	Front	1	1013	824.7	21.67	23	1.358	-0.01	0.735	0.998
37	CDMA2000 BC0	RTAP 153.6	Front	1	777	848.31	21.72	23	1.343	-0.06	0.866	1.163
<b>38</b>	<b>CDMA2000 BC0</b>	<b>RTAP 153.6</b>	<b>Back</b>	<b>1</b>	<b>1013</b>	<b>824.7</b>	<b>21.67</b>	<b>23</b>	<b>1.358</b>	<b>-0.05</b>	<b>1.090</b>	<b>1.481</b>
39	CDMA2000 BC0	RTAP 153.6	Back	1	777	848.31	21.72	23	1.343	-0.01	0.847	1.137
40	CDMA2000 BC0	RTAP 153.6	Left Side	1	1013	824.7	21.67	23	1.358	-0.01	0.720	0.978
41	CDMA2000 BC0	RTAP 153.6	Left Side	1	777	848.31	21.72	23	1.343	-0.01	0.812	1.090
42	CDMA2000 BC0	RTAP 153.6	Right Side	1	1013	824.7	21.67	23	1.358	-0.04	0.715	0.971
43	CDMA2000 BC0	RTAP 153.6	Right Side	1	777	848.31	21.72	23	1.343	-0.06	0.625	0.839
1	CDMA2000 BC1	RTAP 153.6	Front	1	25	1851.25	23.52	24	1.117	0.04	0.967	1.080
2	CDMA2000 BC1	RTAP 153.6	Back	1	25	1851.25	23.52	24	1.117	-0.01	0.943	1.053
3	CDMA2000 BC1	RTAP 153.6	Left Side	1	25	1851.25	23.52	24	1.117	0.05	0.399	0.446
4	CDMA2000 BC1	RTAP 153.6	Right Side	1	25	1851.25	23.52	24	1.117	0.13	0.284	0.317
5	CDMA2000 BC1	RTAP 153.6	Bottom Side	1	25	1851.25	23.52	24	1.117	-0.06	0.503	0.562
<b>6</b>	<b>CDMA2000 BC1</b>	<b>RTAP 153.6</b>	<b>Front</b>	<b>1</b>	<b>600</b>	<b>1880</b>	<b>23.43</b>	<b>24</b>	<b>1.140</b>	<b>0.03</b>	<b>1.110</b>	<b>1.266</b>
7	CDMA2000 BC1	RTAP 153.6	Front	1	1175	1908.75	23.45	24	1.135	-0.02	1.030	1.169
8	CDMA2000 BC1	RTAP 153.6	Back	1	600	1880	23.43	24	1.140	0.08	1.040	1.186
9	CDMA2000 BC1	RTAP 153.6	Back	1	1175	1908.75	23.45	24	1.135	0.12	1.050	1.192

**< WLAN 2.4GHz>**

Plot No.	Band	Mode	Test Position	Gap (cm)	Ch.	Freq. (MHz)	Average Power (dBm)	Tune-Up Limit (dBm)	Scaling Factor	Power Drift (dB)	SAR <sub>1g</sub> (W/kg)	Scaled SAR <sub>1g</sub> (W/kg)
66	WLAN2.4G	802.11b	Front	1	11	2462	11.61	12	1.094	-0.09	0.021	0.023
<b>67</b>	<b>WLAN2.4G</b>	<b>802.11b</b>	<b>Back</b>	<b>1</b>	<b>11</b>	<b>2462</b>	<b>11.61</b>	<b>12</b>	<b>1.094</b>	<b>-0.1</b>	<b>0.043</b>	<b>0.047</b>
68	WLAN2.4G	802.11b	Left Side	1	11	2462	11.61	12	1.094	-0.07	0.041	0.045
69	WLAN2.4G	802.11b	Top Side	1	11	2462	11.61	12	1.094	0.04	0.029	0.032

**12.3 Test Records for Body-worn SAR Test**

**Note:**

1. For Body-worn SAR testing: "V" in the Headset column means the Headset is plugged during SAR testing
2. Body-worn SAR testing was performed at 10mm separation, and this distance is determined by the handset manufacturer that there will be body-worn accessories that users may acquire at the time of equipment certification, to enable users to purchase aftermarket body-worn accessories with the required minimum separation.
3. Per KDB 941225 D06, when the same wireless modes and device transmission configurations are required for testing body-worn accessories and hotspot mode, it is not necessary to test body-worn accessory SAR for the same device orientation if the test separation distance for hotspot mode is more conservative than that used for body-worn accessories.
4. Though per KDB 648474 D04v01, when the reported SAR for a body-worn accessory measured without a headset connected to the handset is  $\leq 1.2$  W/kg, the SAR testing with a headset connected to the handset is not required, but considered the simultaneous SAR for body-worn, we still perform the WLAN SAR with headset mode.

**<CDMA2000>**

Plot No.	Band	Mode	Test Position	Gap (cm)	Ch.	Freq. (MHz)	Average Power (dBm)	Tune-Up Limit (dBm)	Scaling Factor	Headset	Power Drift (dB)	SAR <sub>1g</sub> (W/kg)	Scaled SAR <sub>1g</sub> (W/kg)
44	CDMA2000 BC0	RC3 SO32	Front	1	384	836.52	21.85	23	1.303	-	0.02	0.763	0.994
45	CDMA2000 BC0	RC3 SO32	Back	1	384	836.52	21.85	23	1.303	-	0.06	0.830	1.082
46	CDMA2000 BC0	RC3 SO32	Front	1	1013	824.7	21.67	23	1.358	-	0.02	0.673	0.914
47	CDMA2000 BC0	RC3 SO32	Front	1	777	848.31	21.72	23	1.343	-	-0.05	0.817	1.097
<b>48</b>	<b>CDMA2000 BC0</b>	<b>RC3 SO32</b>	<b>Back</b>	<b>1</b>	<b>1013</b>	<b>824.7</b>	<b>21.67</b>	<b>23</b>	<b>1.358</b>	-	<b>0.09</b>	<b>1.010</b>	<b>1.372</b>
49	CDMA2000 BC0	RC3 SO32	Back	1	777	848.31	21.72	23	1.343	-	-0.01	0.795	1.067
50	CDMA2000 BC0	RC3 SO32	Back	1	1013	824.7	21.67	23	1.358	V	0.06	0.842	1.144
51	CDMA2000 BC0	RC3 SO32	Back	1	384	836.52	21.85	23	1.303	V	-0.09	0.745	0.971
52	CDMA2000 BC0	RC3 SO32	Back	1	777	848.31	21.72	23	1.343	V	0.01	0.669	0.898
12	CDMA2000 BC1	RC3 SO32	Front	1	25	1851.25	23.57	24	1.104	-	0.04	1.020	1.126
14	CDMA2000 BC1	RC3 SO32	Back	1	25	1851.25	23.57	24	1.104	-	-0.08	1.120	1.237
10	CDMA2000 BC1	RC3 SO32	Front	1	600	1880	23.47	24	1.130	-	-0.07	1.150	1.299
13	CDMA2000 BC1	RC3 SO32	Front	1	1175	1908.75	23.47	24	1.130	-	0.02	1.020	1.152
11	CDMA2000 BC1	RC3 SO32	Back	1	600	1880	23.47	24	1.130	-	-0.05	1.110	1.254
15	CDMA2000 BC1	RC3 SO32	Back	1	1175	1908.75	23.47	24	1.130	-	0.05	1.180	1.333
<b>19</b>	<b>CDMA2000 BC1</b>	<b>RC3 SO32</b>	<b>Back</b>	<b>1</b>	<b>600</b>	<b>1880</b>	<b>23.47</b>	<b>24</b>	<b>1.130</b>	<b>V</b>	<b>0.04</b>	<b>1.190</b>	<b>1.344</b>
20	CDMA2000 BC1	RC3 SO32	Back	1	25	1851.25	23.57	24	1.104	V	-0.03	1.040	1.148
21	CDMA2000 BC1	RC3 SO32	Back	1	1175	1908.75	23.47	24	1.130	V	0.01	1.150	1.299

**<WLAN 2.4GHz>**

Plot No.	Band	Mode	Test Position	Gap (cm)	Ch.	Freq. (MHz)	Average Power (dBm)	Tune-Up Limit (dBm)	Scaling Factor	Headset	Power Drift (dB)	SAR <sub>1g</sub> (W/kg)	Scaled SAR <sub>1g</sub> (W/kg)
66	WLAN2.4G	802.11b	Front	1	11	2462	11.61	12	1.094	-	-0.09	0.021	0.023
67	WLAN2.4G	802.11b	Back	1	11	2462	11.61	12	1.094	-	-0.10	0.043	0.047
<b>71</b>	<b>WLAN2.4G</b>	<b>802.11b</b>	<b>Back</b>	<b>1</b>	<b>11</b>	<b>2462</b>	<b>11.61</b>	<b>12</b>	<b>1.094</b>	<b>V</b>	<b>-0.08</b>	<b>0.044</b>	<b>0.048</b>





**12.4 Repeated SAR Measurement**

Plot No.	Band	Mode	Test Position	Gap (cm)	Ch.	Freq. (MHz)	Average Power (dBm)	Tune-Up Limit (dBm)	Scaling Factor	Power Drift (dB)	SAR <sub>1g</sub> (W/kg)	Scaled SAR <sub>1g</sub> (W/kg)
28	CDMA2000 BC1	RC3 SO55	Left Cheek	-	600	1880	23.48	24	1.127	-0.03	1.330	1.499
30	CDMA2000 BC1	RC3 SO55	Left Cheek	-	600	1880	23.48	24	1.127	-0.05	1.320	1.488
38	CDMA2000 BC0	RTAP 153.6	Back	1	1013	824.7	21.67	23	1.358	-0.05	1.090	1.481
53	CDMA2000 BC0	RTAP 153.6	Back	1	1013	824.7	21.67	23	1.358	0.02	1.080	1.467

**Note:**

1. Per KDB 865664 D01v01, for each frequency band, repeated SAR measurement is required only when the measured SAR is  $\geq 0.8$ W/kg
2. Per KDB 865664 D01v01, if the deviation among the repeated measurement is  $\leq 20\%$  and the measured SAR  $< 1.45$ W/kg, only one repeated measurement is required.
3. The deviation is the difference in percentage between original and repeated *measured* SAR.
4. All measurement SAR result is scaled-up to account for tune-up tolerance and is compliant.

**12.5 Highest SAR Plot**

Plot No.	Band	Mode	Test Position	Gap (cm)	Headset	Ch.	Freq. (MHz)	Average Power (dBm)	Tune-up Limit (dBm)	Tune-up Scaling Factor	Power Drift (dB)	SAR <sub>1g</sub> (W/kg)	Reported SAR <sub>1g</sub> (W/kg)
38	CDMA2000 BC0	RTAP 153.6	Back	1	-	1013	824.7	21.67	23	1.358	-0.05	1.090	1.481
28	CDMA2000 BC1	RC3 SO55	Left Cheek	-	-	600	1880	23.48	24	1.127	-0.03	1.330	1.499
62	WLAN2.4G	802.11b	Right Cheek	-	-	11	2462	11.61	12	1.094	0.11	0.114	0.125

Test Laboratory: Sporton International Inc. SAR/HAC Testing Lab

Date: 19.02.2013

**38 CDMA2000 BC0\_RTAP 153.6\_Back\_1cm\_Ch1013**

**DUT: 313006**

Communication System: CDMA2000; Frequency: 824.7 MHz; Duty Cycle: 1:1  
 Medium: MSL\_835\_130219 Medium parameters used:  $f = 825 \text{ MHz}$ ;  $\sigma = 0.959 \text{ mho/m}$ ;  $\epsilon_r = 56.152$ ;  $\rho = 1000 \text{ kg/m}^3$   
 Ambient Temperature : 23.2 °C; Liquid Temperature : 21.2 °C

**DASY5 Configuration:**

- Probe: EX3DV4 - SN3819; ConvF(9.5, 9.5, 9.5); Calibrated: 26.11.2012;
- Sensor-Surface: 2mm (Mechanical Surface Detection)
- Electronics: DAE4 Sn1303; Calibrated: 22.11.2012
- Phantom: SAM2; Type: QD000P40CD; Serial: TP:1671
- Measurement SW: DASY52, Version 52.8 (2); SEMCAD X Version 14.6.6 (6824)

**Ch1013/Area Scan (61x101x1):** Interpolated grid: dx=15mm, dy=15mm

Maximum value of SAR (interpolated) = 1.29 W/kg

**Ch1013/Zoom Scan (5x5x7)/Cube 0:** Measurement grid: dx=8mm, dy=8mm, dz=5mm

Reference Value = 37.465 V/m; Power Drift = -0.05 dB

Peak SAR (extrapolated) = 1.531 mW/g

SAR(1 g) = 1.090 mW/g; SAR(10 g) = 0.806 mW/g

Maximum value of SAR (measured) = 1.28 W/kg

**Ch1013/Zoom Scan (5x5x7)/Cube 1:** Measurement grid: dx=8mm, dy=8mm, dz=5mm

Reference Value = 37.465 V/m; Power Drift = -0.05 dB

Peak SAR (extrapolated) = 1.642 mW/g

SAR(1 g) = 0.925 mW/g; SAR(10 g) = 0.650 mW/g

Maximum value of SAR (measured) = 1.25 W/kg

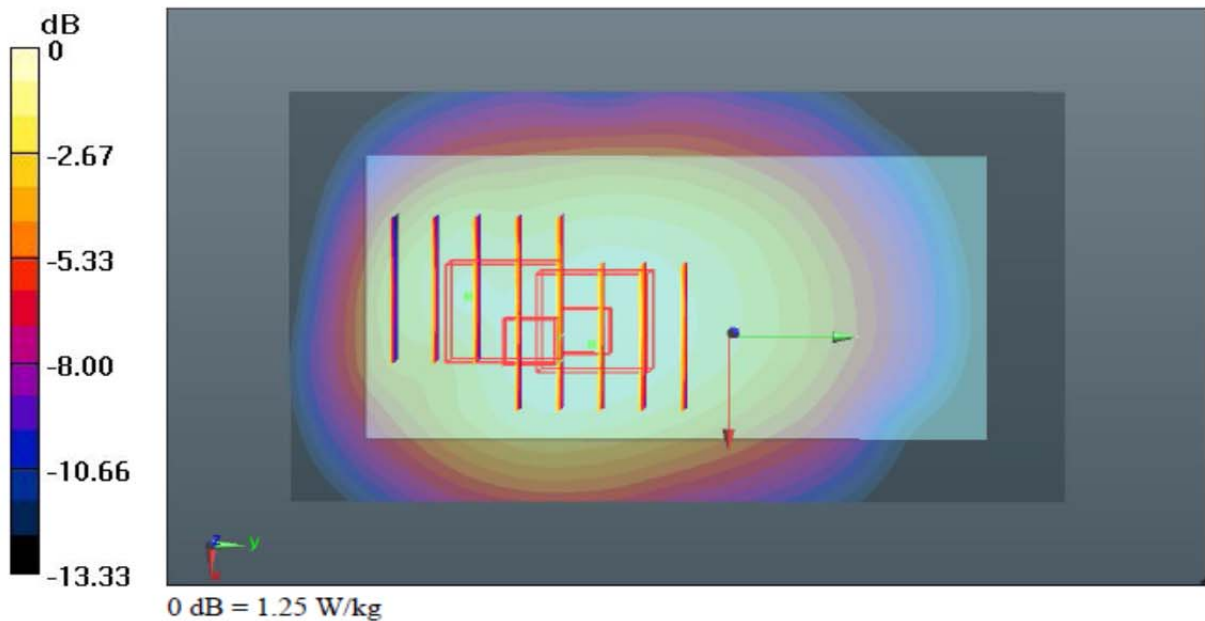

Test Laboratory: Sporton International Inc. SAR/HAC Testing Lab

Date: 17.02.2013

**28 CDMA2000 BC1\_RC3 SO55\_Left Cheek\_Ch600****DUT: 313006**

Communication System: CDMA2000; Frequency: 1880 MHz; Duty Cycle: 1:1

Medium: HSL\_1900\_130217 Medium parameters used:  $f = 1880$  MHz;  $\sigma = 1.412$  mho/m;  $\epsilon_r =$ 38.533;  $\rho = 1000$  kg/m<sup>3</sup>

Ambient Temperature : 23.2 °C; Liquid Temperature : 21.8 °C

**DASY5 Configuration:**

- Probe: EX3DV4 - SN3819; ConvF(7.84, 7.84, 7.84); Calibrated: 26.11.2012;
- Sensor-Surface: 2mm (Mechanical Surface Detection)
- Electronics: DAE4 Sn1303; Calibrated: 22.11.2012
- Phantom: SAM1; Type: QD000P40CD; Serial: TP:1670
- Measurement SW: DASY52, Version 52.8 (2); SEMCAD X Version 14.6.6 (6824)

**Ch600/Area Scan (61x101x1):** Interpolated grid: dx=15mm, dy=15mm

Maximum value of SAR (interpolated) = 1.75 W/kg

**Ch600/Zoom Scan (5x5x7)/Cube 0:** Measurement grid: dx=8mm, dy=8mm, dz=5mm

Reference Value = 35.938 V/m; Power Drift = -0.03 dB

Peak SAR (extrapolated) = 2.119 mW/g

SAR(1 g) = 1.330 mW/g; SAR(10 g) = 0.777 mW/g

Maximum value of SAR (measured) = 1.75 W/kg

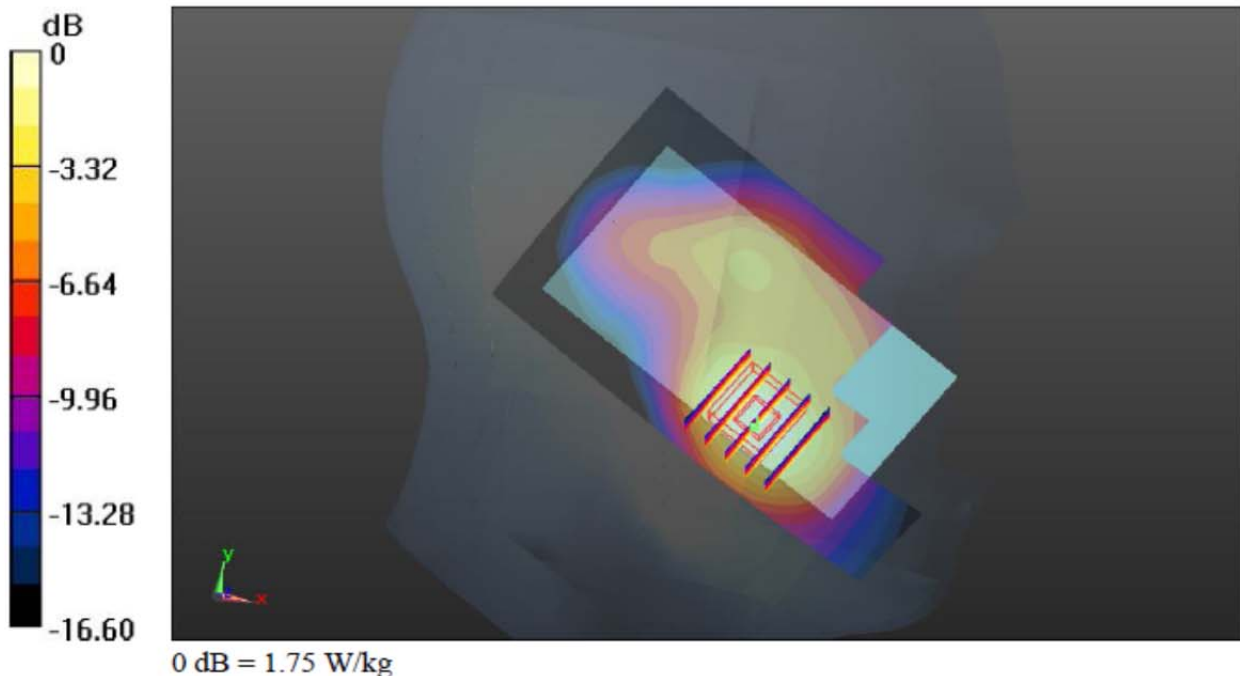



Test Laboratory: Sporton International Inc. SAR/HAC Testing Lab

Date: 28.02.2013

**62 WLAN2.4G\_802.11b\_Right Cheek\_Ch11**

**DUT: 313006**

Communication System: WIFI; Frequency: 2462 MHz; Duty Cycle: 1:1

Medium: HSL\_2450\_130228 Medium parameters used:  $f = 2462 \text{ MHz}$ ;  $\sigma = 1.87 \text{ mho/m}$ ;  $\epsilon_r = 37.641$ ;

$\rho = 1000 \text{ kg/m}^3$

Ambient Temperature : 23.5 °C; Liquid Temperature : 21.4 °C

**DASY5 Configuration:**

- Probe: EX3DV4 - SN3819; ConvF(6.99, 6.99, 6.99); Calibrated: 26.11.2012;
- Sensor-Surface: 2mm (Mechanical Surface Detection)
- Electronics: DAE4 Sn1303; Calibrated: 22.11.2012
- Phantom: SAM2; Type: QD000P40CD; Serial: TP:1671
- Measurement SW: DASY52, Version 52.8 (2); SEMCAD X Version 14.6.6 (6824)

**Ch11/Area Scan (71x121x1):** Interpolated grid: dx=12mm, dy=12mm

Maximum value of SAR (interpolated) = 0.178 W/kg

**Ch11/Zoom Scan (7x7x7)/Cube 0:** Measurement grid: dx=5mm, dy=5mm, dz=5mm

Reference Value = 9.705 V/m; Power Drift = 0.11 dB

Peak SAR (extrapolated) = 0.252 mW/g

SAR(1 g) = 0.114 mW/g; SAR(10 g) = 0.055 mW/g

Maximum value of SAR (measured) = 0.174 W/kg

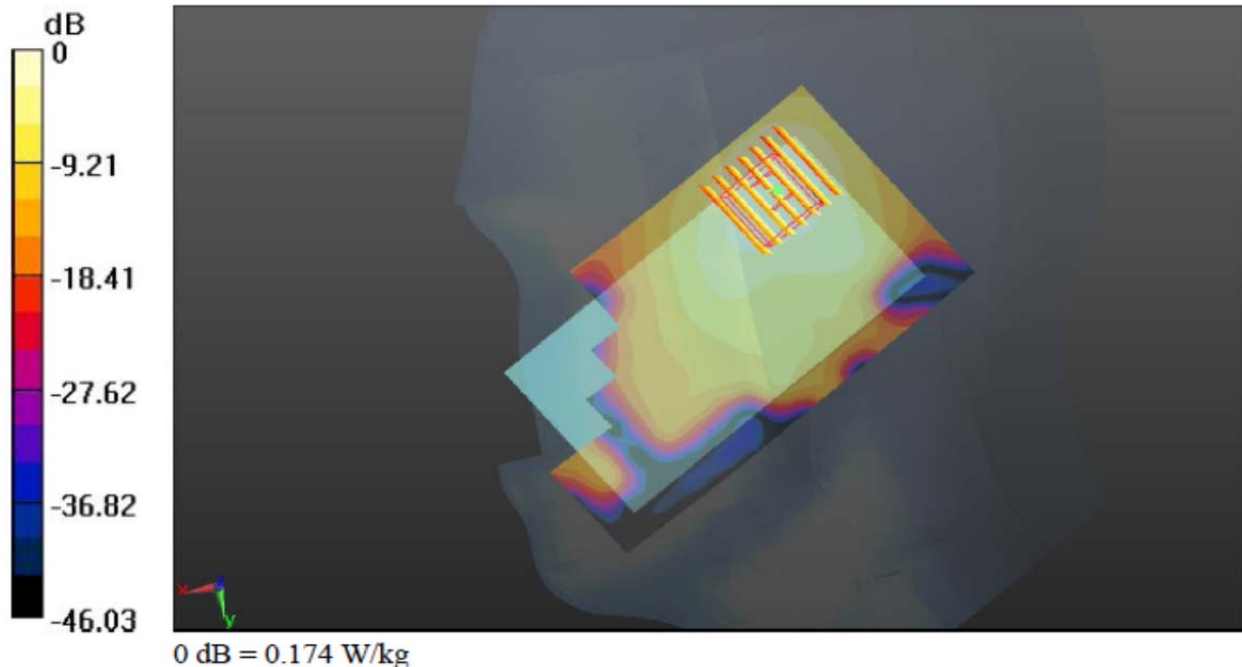

**12.6 Simultaneous Multi-band Transmission Analysis**

	Position	Applicable Combination
Simultaneous Transmission	Head	CDMA2000 (voice) + WLAN 2.4GHz
		CDMA2000 (voice) + Bluetooth
	Hotspot	EVDO (data) + WLAN 2.4GHz
		EVDO (data) + Bluetooth
	Body-worn	CDMA2000 (voice) + WLAN 2.4GHz
		CDMA2000 (voice) + Bluetooth

**Note:**

1. WLAN and Bluetooth share the same antenna, and cannot transmit simultaneously.
2. 1xRTT and EVDO share the same antenna, and no SVDO feature in this device.
3. If 1g-SAR scalar summation  $\geq 1.6$  W/kg, SPLSR calculation is necessary.
4. The reported SAR summation is calculated based on the same configuration and test position.
5. Simultaneous transmission analysis for hotspot mode 1cm separation to the body represents the compliance for hand-held and near-body use conditions. Simultaneous transmission of Hotspot mode for head and body-worn conditions was covered under simultaneous transmission analysis of head and body-worn positions, due to the possible WWAN voice call and data transmission SAR was considered in standalone SAR measurement for those exposure positions
6. For simultaneous transmission analysis, Bluetooth SAR is estimated per KDB 447498 D01v05 based on the formula below.
  - i)  $(\text{max. power of channel, including tune-up tolerance, mW}) / (\text{min. test separation distance, mm}) \cdot [\sqrt{f(\text{GHz})} / x]$  W/kg for test separation distances  $\leq 50$  mm; where  $x = 7.5$  for 1-g SAR, and  $x = 18.75$  for 10-g SAR.
  - ii) 0.4 W/kg for 1-g SAR and 1.0 W/kg for 10-g SAR, when the test separation distances is  $> 50$  mm.

Bluetooth	Tune-up Maximum power (dBm)	Head 0mm gap	Body 10mm gap
Estimated SAR (W/kg)	-3	0.021 W/kg	0.010 W/kg

7. Per KDB 447498 D01v05, simultaneous transmission SAR is compliant if,
  - (i) Scalar SAR summation  $< 1.6$ W/kg.
  - (ii)  $\text{SPLSR} = (\text{SAR1} + \text{SAR2}) \cdot 1.5 / (\text{min. separation distance, mm})$ , and the peak separation distance is determined from the square root of  $[(x1-x2)^2 + (y1-y2)^2 + (z1-z2)^2]$ , where  $(x1, y1, z1)$  and  $(x2, y2, z2)$  are the coordinates of the extrapolated peak SAR locations in the zoom scan  
If  $\text{SPLSR} \leq 0.04$ , simultaneously transmission SAR measurement is not necessary
  - (iii) Simultaneously transmission SAR measurement, and the reported multi-band SAR  $< 1.6$ W/kg



<Head SAR>

Position	WWAN (PCE)			WLAN 2.4GHz (DTS)		WWAN + WLAN 2.4GHz (W/kg)	SPLSR ≤ 0.04	Case No
	WWAN Band	Plot No	Max. WWAN SAR (W/kg)	Plot No	Max. WLAN 2.4GHz SAR (W/kg)			
Right Cheek	CDMA2000 BC0	59	1.013	62	0.125	1.14	-	-
	CDMA2000 BC1	26	0.943	62	0.125	1.07	-	-
Right Tilted	CDMA2000 BC0	55	0.530	63	0.066	0.60	-	-
	CDMA2000 BC1	23	0.571	63	0.066	0.64	-	-
Left Cheek	CDMA2000 BC0	61	1.022	64	0.060	1.08	-	-
	CDMA2000 BC1	28	1.499	64	0.060	1.56	-	-
Left Tilted	CDMA2000 BC0	57	0.550	65	0.053	0.60	-	-
	CDMA2000 BC1	25	0.487	65	0.053	0.54	-	-

Position	WWAN (PCE)			Bluetooth (DSS)	WWAN + Bluetooth (W/kg)	SPLSR ≤ 0.04	Case No
	WWAN Band	Plot No	Max. WWAN SAR (W/kg)	Estimated Bluetooth SAR (W/kg)			
Right Cheek	CDMA2000 BC0	59	1.013	0.021	1.03	-	-
	CDMA2000 BC1	26	0.943	0.021	0.96	-	-
Right Tilted	CDMA2000 BC0	55	0.530	0.021	0.55	-	-
	CDMA2000 BC1	23	0.571	0.021	0.59	-	-
Left Cheek	CDMA2000 BC0	61	1.022	0.021	1.04	-	-
	CDMA2000 BC1	28	1.499	0.021	1.52	-	-
Left Tilted	CDMA2000 BC0	57	0.550	0.021	0.57	-	-
	CDMA2000 BC1	25	0.487	0.021	0.51	-	-



<Hotspot SAR>

Position	WWAN (PCE)			WLAN 2.4GHz (DTS)		WWAN + WLAN 2.4GHz (W/kg)	SPLSR ≤ 0.04	Case No
	WWAN Band	Plot No	Max. WWAN SAR (W/kg)	Plot No	Max. WLAN 2.4GHz SAR (W/kg)			
Front	CDMA2000 BC0	37	1.163	66	0.023	1.19	-	-
	CDMA2000 BC1	6	1.266	66	0.023	1.29	-	-
Back	CDMA2000 BC0	38	1.481	67	0.047	1.53	-	-
	CDMA2000 BC1	9	1.192	67	0.047	1.24	-	-
Left Side	CDMA2000 BC0	41	1.090	68	0.045	1.14	-	-
	CDMA2000 BC1	3	0.446	68	0.045	0.49	-	-
Right Side	CDMA2000 BC0	42	0.971			0.97	-	-
	CDMA2000 BC1	4	0.317			0.32	-	-
Top Side	CDMA2000 BC0			69	0.032	0.03	-	-
	CDMA2000 BC1			69	0.032	0.03	-	-
Bottom Side	CDMA2000 BC0	35	0.106			0.11	-	-
	CDMA2000 BC1	5	0.562			0.56	-	-

Position	WWAN (PCE)			Bluetooth (DSS)		WWAN + Bluetooth (W/kg)	SPLSR ≤ 0.04	Case No
	WWAN Band	Plot No	Max. WWAN SAR (W/kg)	Estimated Bluetooth SAR (W/kg)				
Front	CDMA2000 BC0	37	1.163	0.010		1.17	-	-
	CDMA2000 BC1	6	1.266	0.010		1.28	-	-
Back	CDMA2000 BC0	38	1.481	0.010		1.49	-	-
	CDMA2000 BC1	9	1.192	0.010		1.20	-	-
Left Side	CDMA2000 BC0	41	1.090	0.010		1.10	-	-
	CDMA2000 BC1	3	0.446	0.010		0.46	-	-
Right Side	CDMA2000 BC0	42	0.971	0.010		0.98	-	-
	CDMA2000 BC1	4	0.317	0.010		0.33	-	-
Top Side	CDMA2000 BC0			0.010		0.01	-	-
	CDMA2000 BC1			0.010		0.01	-	-
Bottom Side	CDMA2000 BC0	35	0.106	0.010		0.12	-	-
	CDMA2000 BC1	5	0.562	0.010		0.57	-	-



<Body-worn SAR>

Position	WWAN (PCE)			WLAN 2.4GHz (DTS)		WWAN + WLAN 2.4GHz (W/kg)	SPLSR ≤ 0.04	Case No
	WWAN Band	Plot No	Max. WWAN SAR (W/kg)	Plot No	Max. WLAN 2.4GHz SAR (W/kg)			
Front	CDMA2000 BC0	47	1.097	66	0.023	1.12	-	-
	CDMA2000 BC1	10	1.299	66	0.023	1.32	-	-
Back	CDMA2000 BC0	48	1.372	67	0.047	1.42	-	-
	CDMA2000 BC1	15	1.333	67	0.047	1.38	-	-
Back (w/ Headset)	CDMA2000 BC0	50	1.144	71	0.048	1.19	-	-
	CDMA2000 BC1	19	1.344	71	0.048	1.39	-	-

Position	WWAN (PCE)			Bluetooth (DSS)	WWAN + Bluetooth (W/kg)	SPLSR ≤ 0.04	Case No
	WWAN Band	Plot No	Max. WWAN SAR (W/kg)	Estimated Bluetooth SAR (W/kg)			
Front	CDMA2000 BC0	47	1.097	0.010	1.11	-	-
	CDMA2000 BC1	10	1.299	0.010	1.31	-	-
Back	CDMA2000 BC0	48	1.372	0.010	1.38	-	-
	CDMA2000 BC1	15	1.333	0.010	1.34	-	-
Back (w/ Headset)	CDMA2000 BC0	50	1.144	0.010	1.15	-	-
	CDMA2000 BC1	19	1.344	0.010	1.35	-	-

Test Engineer : Jeme Li and Krin Wu



### **13. Uncertainty Assessment**

The component of uncertainty may generally be categorized according to the methods used to evaluate them. The evaluation of uncertainty by the statistical analysis of a series of observations is termed a Type A evaluation of uncertainty. The evaluation of uncertainty by means other than the statistical analysis of a series of observations is termed a Type B evaluation of uncertainty. Each component of uncertainty, however evaluated, is represented by an estimated standard deviation, termed standard uncertainty, which is determined by the positive square root of the estimated variance.

A Type A evaluation of standard uncertainty may be based on any valid statistical method for treating data. This includes calculating the standard deviation of the mean of a series of independent observations; using the method of least squares to fit a curve to the data in order to estimate the parameter of the curve and their standard deviations; or carrying out an analysis of variance in order to identify and quantify random effects in certain kinds of measurement.

A type B evaluation of standard uncertainty is typically based on scientific judgment using all of the relevant information available. These may include previous measurement data, experience, and knowledge of the behavior and properties of relevant materials and instruments, manufacture’s specification, data provided in calibration reports and uncertainties assigned to reference data taken from handbooks. Broadly speaking, the uncertainty is either obtained from an outdoor source or obtained from an assumed distribution, such as the normal distribution, rectangular or triangular distributions indicated in Table 12.1

<b>Uncertainty Distributions</b>	<b>Normal</b>	<b>Rectangular</b>	<b>Triangular</b>	<b>U-Shape</b>
Multi-plying Factor <sup>(a)</sup>	1/k <sup>(b)</sup>	1/√3	1/√6	1/√2

(a) standard uncertainty is determined as the product of the multiplying factor and the estimated range of variations in the measured quantity

(b)  $\kappa$  is the coverage factor

**Table 12.1 Standard Uncertainty for Assumed Distribution**

The combined standard uncertainty of the measurement result represents the estimated standard deviation of the result. It is obtained by combining the individual standard uncertainties of both Type A and Type B evaluation using the usual “root-sum-squares” (RSS) methods of combining standard deviations by taking the positive square root of the estimated variances.

Expanded uncertainty is a measure of uncertainty that defines an interval about the measurement result within which the measured value is confidently believed to lie. It is obtained by multiplying the combined standard uncertainty by a coverage factor. Typically, the coverage factor ranges from 2 to 3. Using a coverage factor allows the true value of a measured quantity to be specified with a defined probability within the specified uncertainty range. For purpose of this document, a coverage factor two is used, which corresponds to confidence interval of about 95 %. The DASY uncertainty Budget is shown in the following tables.



Error Description	Uncertainty	Probability	Divisor	Ci	Ci	Standard	Standard
	Value (±%)	Distribution		(1g)	(10g)	Uncertainty (1g)	Uncertainty (10g)
<b>Measurement System</b>							
Probe Calibration	6.0	Normal	1	1	1	± 6.0 %	± 6.0 %
Axial Isotropy	4.7	Rectangular	√3	0.7	0.7	± 1.9 %	± 1.9 %
Hemispherical Isotropy	9.6	Rectangular	√3	0.7	0.7	± 3.9 %	± 3.9 %
Boundary Effects	1.0	Rectangular	√3	1	1	± 0.6 %	± 0.6 %
Linearity	4.7	Rectangular	√3	1	1	± 2.7 %	± 2.7 %
System Detection Limits	1.0	Rectangular	√3	1	1	± 0.6 %	± 0.6 %
Readout Electronics	0.3	Normal	1	1	1	± 0.3 %	± 0.3 %
Response Time	0.8	Rectangular	√3	1	1	± 0.5 %	± 0.5 %
Integration Time	2.6	Rectangular	√3	1	1	± 1.5 %	± 1.5 %
RF Ambient Noise	3.0	Rectangular	√3	1	1	± 1.7 %	± 1.7 %
RF Ambient Reflections	3.0	Rectangular	√3	1	1	± 1.7 %	± 1.7 %
Probe Positioner	0.4	Rectangular	√3	1	1	± 0.2 %	± 0.2 %
Probe Positioning	2.9	Rectangular	√3	1	1	± 1.7 %	± 1.7 %
Max. SAR Eval.	1.0	Rectangular	√3	1	1	± 0.6 %	± 0.6 %
<b>Test Sample Related</b>							
Device Positioning	2.9	Normal	1	1	1	± 2.9 %	± 2.9 %
Device Holder	3.6	Normal	1	1	1	± 3.6 %	± 3.6 %
Power Drift	5.0	Rectangular	√3	1	1	± 2.9 %	± 2.9 %
<b>Phantom and Setup</b>							
Phantom Uncertainty	4.0	Rectangular	√3	1	1	± 2.3 %	± 2.3 %
Liquid Conductivity (Target)	5.0	Rectangular	√3	0.64	0.43	± 1.8 %	± 1.2 %
Liquid Conductivity (Meas.)	2.5	Normal	1	0.64	0.43	± 1.6 %	± 1.1 %
Liquid Permittivity (Target)	5.0	Rectangular	√3	0.6	0.49	± 1.7 %	± 1.4 %
Liquid Permittivity (Meas.)	2.5	Normal	1	0.6	0.49	± 1.5 %	± 1.2 %
<b>Combined Standard Uncertainty</b>						± 11.0 %	± 10.8 %
<b>Coverage Factor for 95 %</b>						K=2	
<b>Expanded Uncertainty</b>						± 22.0 %	± 21.5 %

Table 12.2 Uncertainty Budget of DASY for frequency range 300 MHz to 3 GHz from IEEE Std 1528™-2003



## **14. References**

- [1] FCC 47 CFR Part 2 “Frequency Allocations and Radio Treaty Matters; General Rules and Regulations”
- [2] ANSI/IEEE Std. C95.1-1992, “IEEE Standard for Safety Levels with Respect to Human Exposure to Radio Frequency Electromagnetic Fields, 3 kHz to 300 GHz”, September 1992
- [3] IEEE Std. 1528-2003, “Recommended Practice for Determining the Peak Spatial-Average Specific Absorption Rate (SAR) in the Human Head from Wireless Communications Devices: Measurement Techniques”, December 2003
- [4] FCC OET Bulletin 65 (Edition 97-01) Supplement C (Edition 01-01), “Evaluating Compliance with FCC Guidelines for Human Exposure to Radiofrequency Electromagnetic Fields”, June 2001
- [5] SPEAG DASY System Handbook
- [6] FCC KDB 248227 D01 v01r02, “SAR Measurement Procedures for 802.11 a/b/g Transmitters”, May 2007
- [7] FCC KDB 447498 D01 v05, “Mobile and Portable Device RF Exposure Procedures and Equipment Authorization Policies”, October 2012
- [8] FCC KDB 648474 D04 v01, “SAR Evaluation Considerations for Handsets with Multiple Transmitters and Antennas”, October 2012
- [9] FCC KDB 941225 D01 v02, “SAR Measurement Procedures for 3G Devices – CDMA 2000 / Ev-Do / WCDMA / HSDPA / HSPA”, October 2007
- [10] FCC KDB 865664 D01 v01, “SAR Measurement Requirements for 100MHz to 6 GHz”, October 2012
- [11] FCC KDB 941225 D06 v01, “SAR Evaluation Procedures for Portable Devices with Wireless Router Capabilities”, April 2011



## ***Appendix A. Plots of System Performance Check***

The plots are shown as follows.

### System Check\_Head\_835MHz\_130220

**DUT: D835V2 - SN:4d091**

Communication System: CW; Frequency: 835 MHz; Duty Cycle: 1:1

Medium: HSL\_835\_130220 Medium parameters used:  $f = 835$  MHz;  $\sigma = 0.901$  mho/m;  $\epsilon_r = 40.589$ ;  $\rho = 1000$  kg/m<sup>3</sup>

Ambient Temperature : 23.5 °C ; Liquid Temperature : 21.3 °C

DASY5 Configuration:

- Probe: EX3DV4 - SN3819; ConvF(9.56, 9.56, 9.56); Calibrated: 26.11.2012;
- Sensor-Surface: 2mm (Mechanical Surface Detection)
- Electronics: DAE4 Sn1303; Calibrated: 22.11.2012
- Phantom: SAM2; Type: QD000P40CD; Serial: TP:1671
- Measurement SW: DASY52, Version 52.8 (2); SEMCAD X Version 14.6.6 (6824)

**Pin=250mW/Area Scan (61x61x1):** Interpolated grid: dx=15mm, dy=15mm

Maximum value of SAR (interpolated) = 3.15 W/kg

**Pin=250mW/Zoom Scan (5x5x7)/Cube 0:** Measurement grid: dx=8mm, dy=8mm, dz=5mm

Reference Value = 60.019 V/m; Power Drift = 0.05 dB

Peak SAR (extrapolated) = 3.716 mW/g

**SAR(1 g) = 2.47 mW/g; SAR(10 g) = 1.62 mW/g**

Maximum value of SAR (measured) = 3.12 W/kg

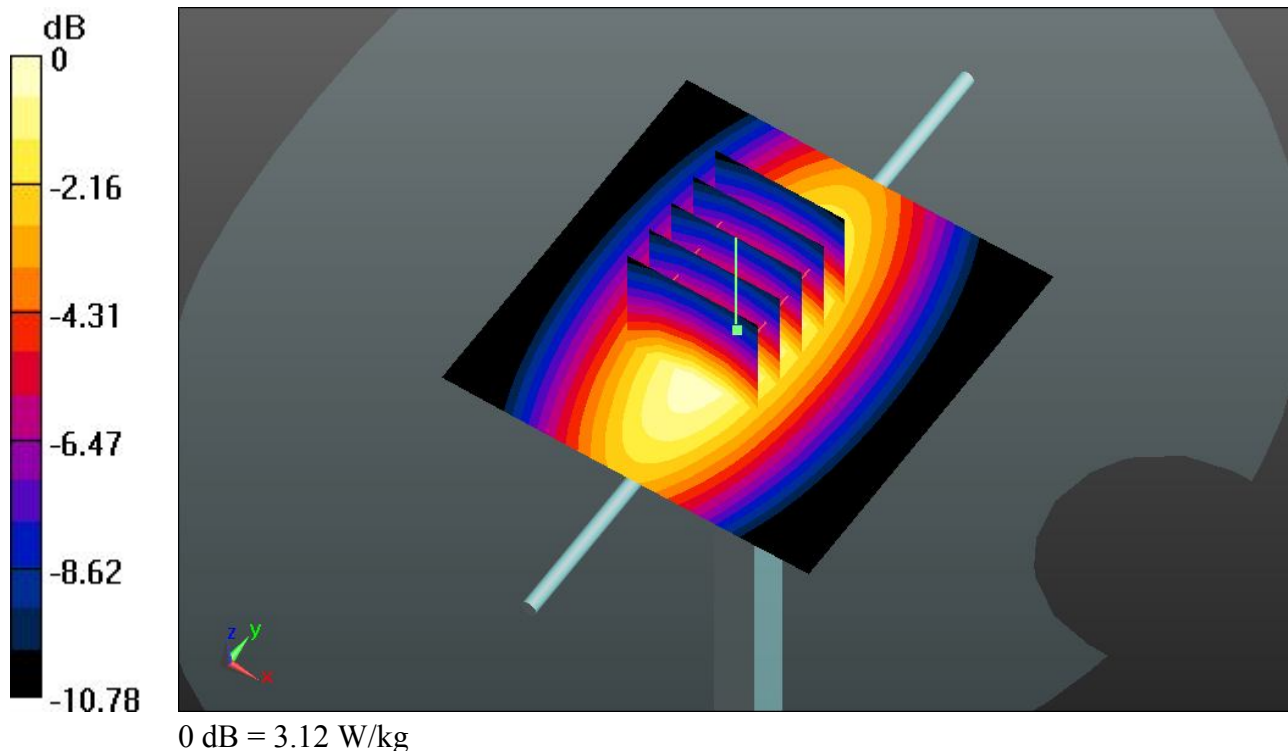

### System Check\_Head\_1900MHz\_130217

**DUT: D1900V2 - SN:5d118**

Communication System: CW; Frequency: 1900 MHz; Duty Cycle: 1:1

Medium: HSL\_1900\_130217 Medium parameters used:  $f = 1900$  MHz;  $\sigma = 1.435$  mho/m;  $\epsilon_r =$

$38.464$ ;  $\rho = 1000$  kg/m<sup>3</sup>

Ambient Temperature : 23.2 °C ; Liquid Temperature : 21.8 °C

DASY5 Configuration:

- Probe: EX3DV4 - SN3819; ConvF(7.84, 7.84, 7.84); Calibrated: 26.11.2012;
- Sensor-Surface: 2mm (Mechanical Surface Detection)
- Electronics: DAE4 Sn1303; Calibrated: 22.11.2012
- Phantom: SAM1; Type: QD000P40CD; Serial: TP:1670
- Measurement SW: DASY52, Version 52.8 (2); SEMCAD X Version 14.6.6 (6824)

**Pin=250mW/Area Scan (61x61x1):** Interpolated grid: dx=15mm, dy=15mm

Maximum value of SAR (interpolated) = 14.8 W/kg

**Pin=250mW/Zoom Scan (5x5x7)/Cube 0:** Measurement grid: dx=8mm, dy=8mm, dz=5mm

Reference Value = 101.9 V/m; Power Drift = 0.01 dB

Peak SAR (extrapolated) = 19.010 mW/g

**SAR(1 g) = 10.2 mW/g; SAR(10 g) = 5.26 mW/g**

Maximum value of SAR (measured) = 14.3 W/kg

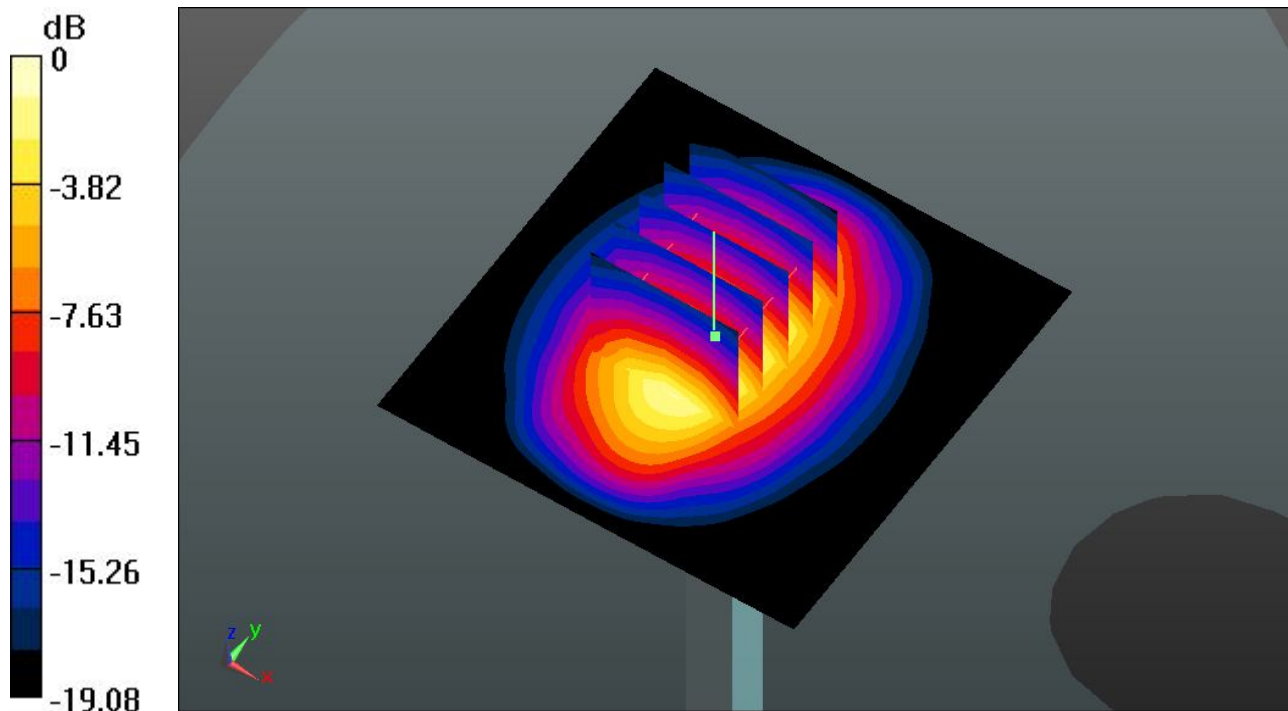

0 dB = 14.3 W/kg

**System Check\_Head\_2450MHz\_130228**

**DUT: D2450V2 - SN:736**

Communication System: CW; Frequency: 2450 MHz; Duty Cycle: 1:1

Medium: HSL\_2450\_130228 Medium parameters used:  $f = 2450$  MHz;  $\sigma = 1.856$  mho/m;  $\epsilon_r =$

$37.685$ ;  $\rho = 1000$  kg/m<sup>3</sup>

Ambient Temperature : 23.5 °C ; Liquid Temperature : 21.4 °C

DASY5 Configuration:

- Probe: EX3DV4 - SN3819; ConvF(6.99, 6.99, 6.99); Calibrated: 26.11.2012;
- Sensor-Surface: 2mm (Mechanical Surface Detection)
- Electronics: DAE4 Sn1303; Calibrated: 22.11.2012
- Phantom: SAM2; Type: QD000P40CD; Serial: TP:1671
- Measurement SW: DASY52, Version 52.8 (2); SEMCAD X Version 14.6.6 (6824)

**Pin=250mW/Area Scan (81x81x1):** Interpolated grid: dx=12mm, dy=12mm

Maximum value of SAR (interpolated) = 21.9 W/kg

**Pin=250mW/Zoom Scan (7x7x7)/Cube 0:** Measurement grid: dx=5mm, dy=5mm, dz=5mm

Reference Value = 93.333 V/m; Power Drift = -0.01 dB

Peak SAR (extrapolated) = 30.492 mW/g

**SAR(1 g) = 14.2 mW/g; SAR(10 g) = 6.46 mW/g**

Maximum value of SAR (measured) = 22.2 W/kg

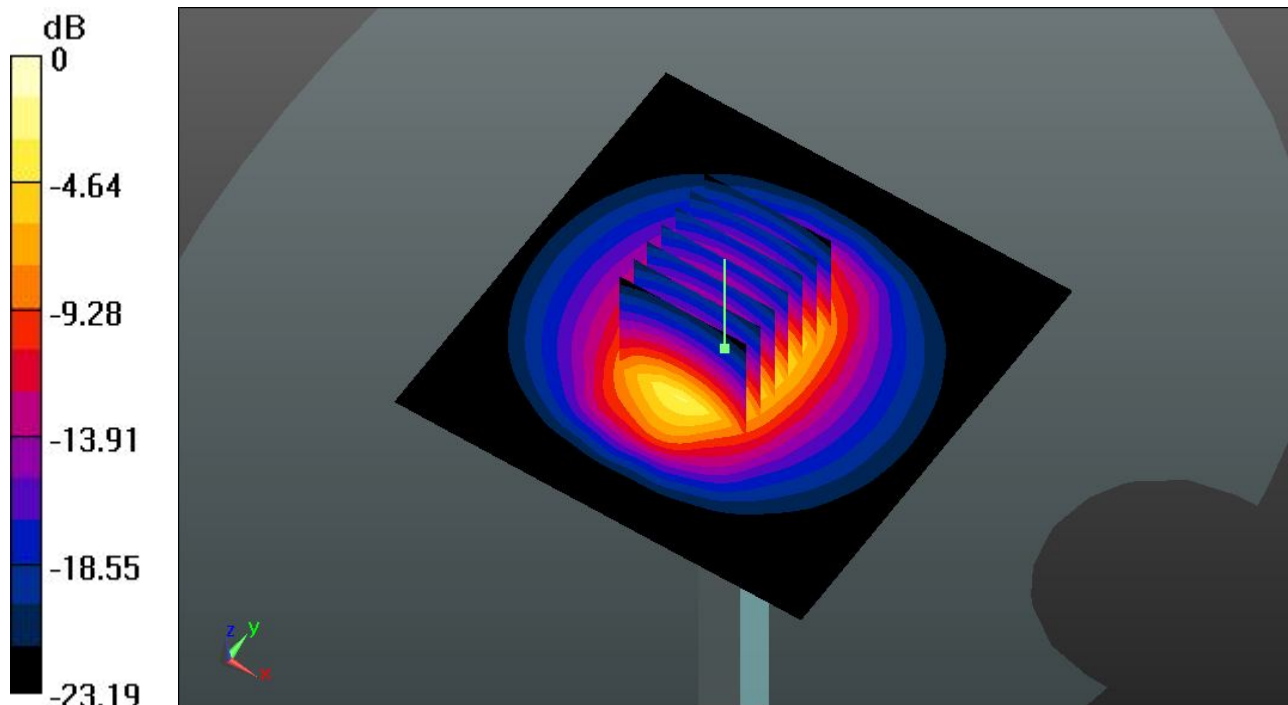

0 dB = 22.2 W/kg



**System Check\_Body\_835MHz\_130219**

**DUT: D835V2 - SN:4d091**

Communication System: CW; Frequency: 835 MHz; Duty Cycle: 1:1

Medium: MSL\_835\_130219 Medium parameters used:  $f = 835 \text{ MHz}$ ;  $\sigma = 0.969 \text{ mho/m}$ ;  $\epsilon_r = 56.069$ ;

$\rho = 1000 \text{ kg/m}^3$

Ambient Temperature :  $23.2 \text{ }^\circ\text{C}$  ; Liquid Temperature :  $21.2 \text{ }^\circ\text{C}$

**DASY5 Configuration:**

- Probe: EX3DV4 - SN3819; ConvF(9.5, 9.5, 9.5); Calibrated: 26.11.2012;
- Sensor-Surface: 2mm (Mechanical Surface Detection)
- Electronics: DAE4 Sn1303; Calibrated: 22.11.2012
- Phantom: SAM2; Type: QD000P40CD; Serial: TP:1671
- Measurement SW: DASY52, Version 52.8 (2); SEMCAD X Version 14.6.6 (6824)

**Pin=250mW/Area Scan (61x61x1):** Interpolated grid:  $dx=15\text{mm}$ ,  $dy=15\text{mm}$

Maximum value of SAR (interpolated) =  $2.60 \text{ W/kg}$

**Pin=250mW/Zoom Scan (5x5x7)/Cube 0:** Measurement grid:  $dx=8\text{mm}$ ,  $dy=8\text{mm}$ ,  $dz=5\text{mm}$

Reference Value =  $52.017 \text{ V/m}$ ; Power Drift =  $-0.01 \text{ dB}$

Peak SAR (extrapolated) =  $3.534 \text{ mW/g}$

**SAR(1 g) =  $2.41 \text{ mW/g}$ ; SAR(10 g) =  $1.59 \text{ mW/g}$**

Maximum value of SAR (measured) =  $2.58 \text{ W/kg}$

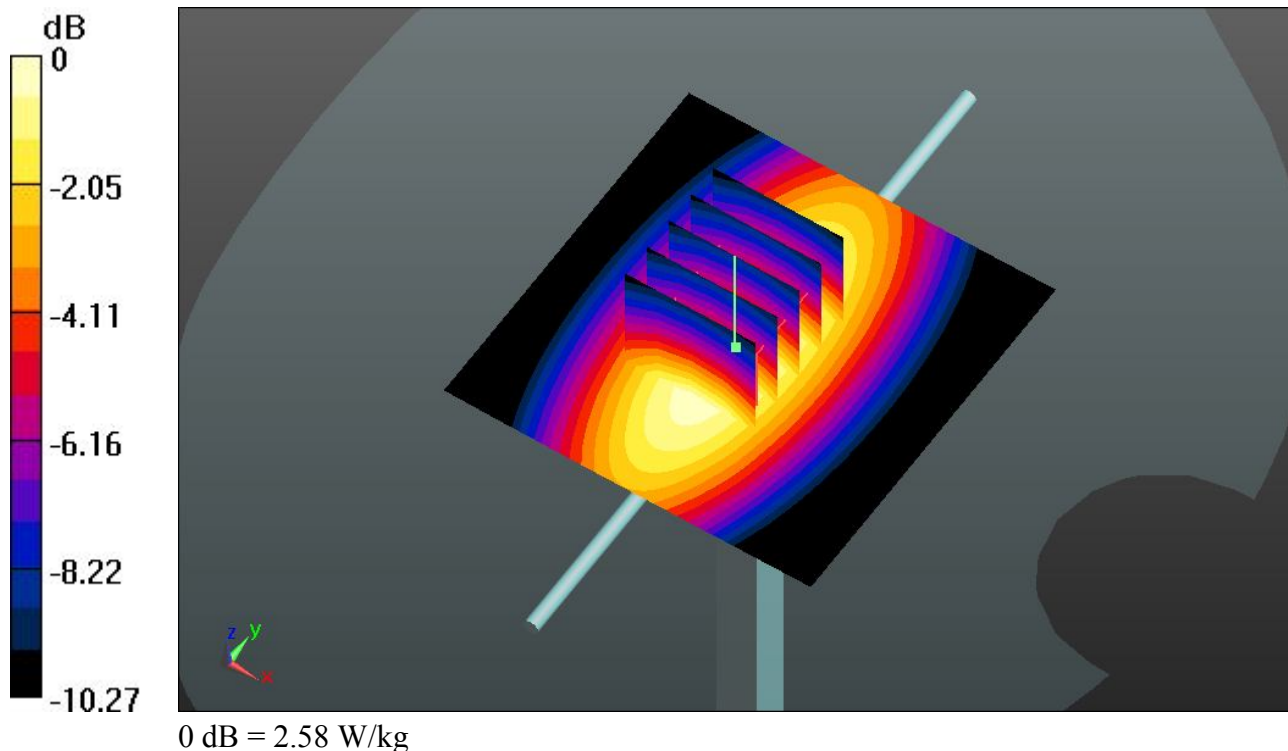

**System Check\_Body\_1900MHz\_130216**

**DUT: D1900V2 - SN:5d118**

Communication System: CW; Frequency: 1900 MHz; Duty Cycle: 1:1

Medium: MSL\_1900\_130216 Medium parameters used:  $f = 1900$  MHz;  $\sigma = 1.528$  mho/m;  $\epsilon_r =$

$54.867$ ;  $\rho = 1000$  kg/m<sup>3</sup>

Ambient Temperature : 23.5 °C ; Liquid Temperature : 21.5 °C

**DASY5 Configuration:**

- Probe: EX3DV4 - SN3819; ConvF(7.67, 7.67, 7.67); Calibrated: 26.11.2012;
- Sensor-Surface: 2mm (Mechanical Surface Detection)
- Electronics: DAE4 Sn1303; Calibrated: 22.11.2012
- Phantom: SAM2; Type: QD000P40CD; Serial: TP:1671
- Measurement SW: DASY52, Version 52.8 (2); SEMCAD X Version 14.6.6 (6824)

**Pin=250mW/Area Scan (61x61x1):** Interpolated grid: dx=15mm, dy=15mm

Maximum value of SAR (interpolated) = 14.7 W/kg

**Pin=250mW/Zoom Scan (5x5x7)/Cube 0:** Measurement grid: dx=8mm, dy=8mm, dz=5mm

Reference Value = 86.748 V/m; Power Drift = -0.01 dB

Peak SAR (extrapolated) = 18.713 mW/g

**SAR(1 g) = 10.3 mW/g; SAR(10 g) = 5.34 mW/g**

Maximum value of SAR (measured) = 14.8 W/kg

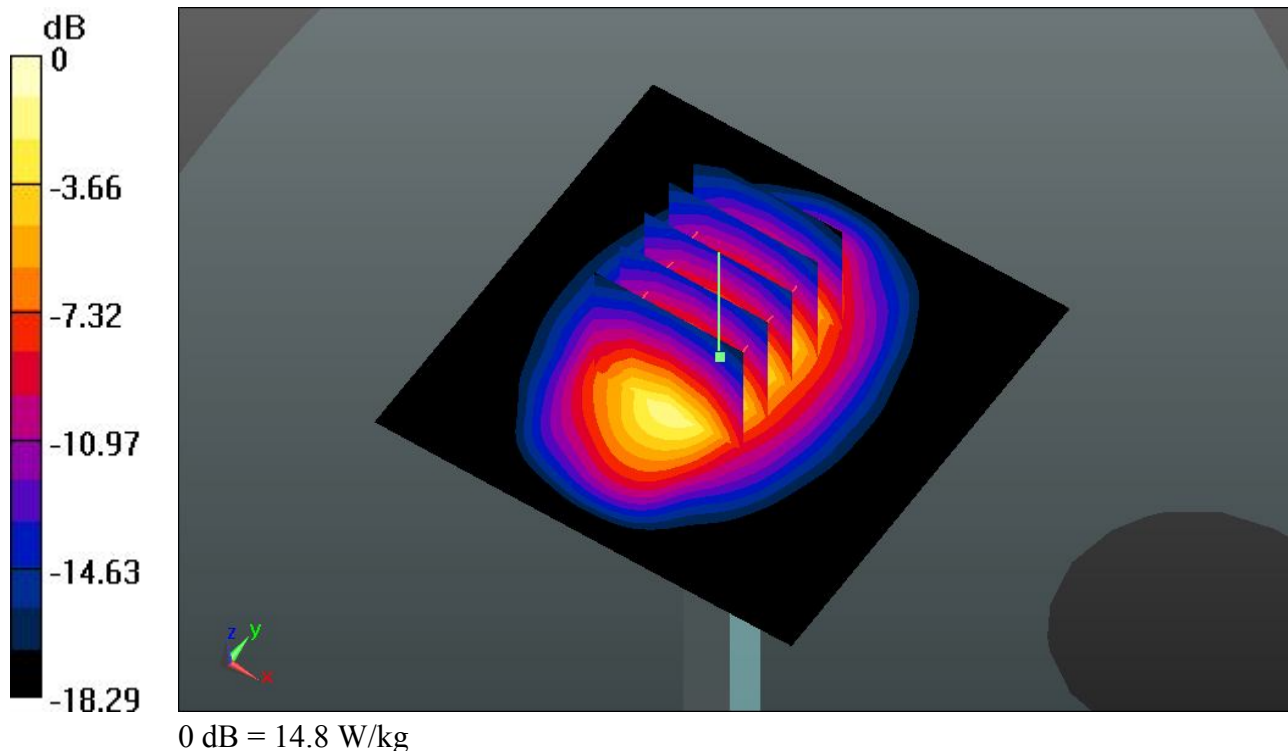

**System Check\_Body\_2450MHz\_130228**

**DUT: D2450V2 - SN:736**

Communication System: CW; Frequency: 2450 MHz; Duty Cycle: 1:1

Medium: MSL\_2450\_130228 Medium parameters used:  $f = 2450 \text{ MHz}$ ;  $\sigma = 1.951 \text{ mho/m}$ ;  $\epsilon_r =$

$53.859$ ;  $\rho = 1000 \text{ kg/m}^3$

Ambient Temperature :  $23.5 \text{ }^\circ\text{C}$  ; Liquid Temperature :  $21.1 \text{ }^\circ\text{C}$

DASY5 Configuration:

- Probe: EX3DV4 - SN3819; ConvF(7.21, 7.21, 7.21); Calibrated: 26.11.2012;
- Sensor-Surface: 2mm (Mechanical Surface Detection)
- Electronics: DAE4 Sn1303; Calibrated: 22.11.2012
- Phantom: SAM1; Type: QD000P40CD; Serial: TP:1670
- Measurement SW: DASY52, Version 52.8 (2); SEMCAD X Version 14.6.6 (6824)

**Pin=250mW/Area Scan (81x81x1):** Interpolated grid:  $dx=12\text{mm}$ ,  $dy=12\text{mm}$

Maximum value of SAR (interpolated) =  $20.6 \text{ W/kg}$

**Pin=250mW/Zoom Scan (7x7x7)/Cube 0:** Measurement grid:  $dx=5\text{mm}$ ,  $dy=5\text{mm}$ ,  $dz=5\text{mm}$

Reference Value =  $87.992 \text{ V/m}$ ; Power Drift =  $0.01 \text{ dB}$

Peak SAR (extrapolated) =  $28.219 \text{ mW/g}$

**SAR(1 g) =  $13.4 \text{ mW/g}$ ; SAR(10 g) =  $6.14 \text{ mW/g}$**

Maximum value of SAR (measured) =  $20.7 \text{ W/kg}$

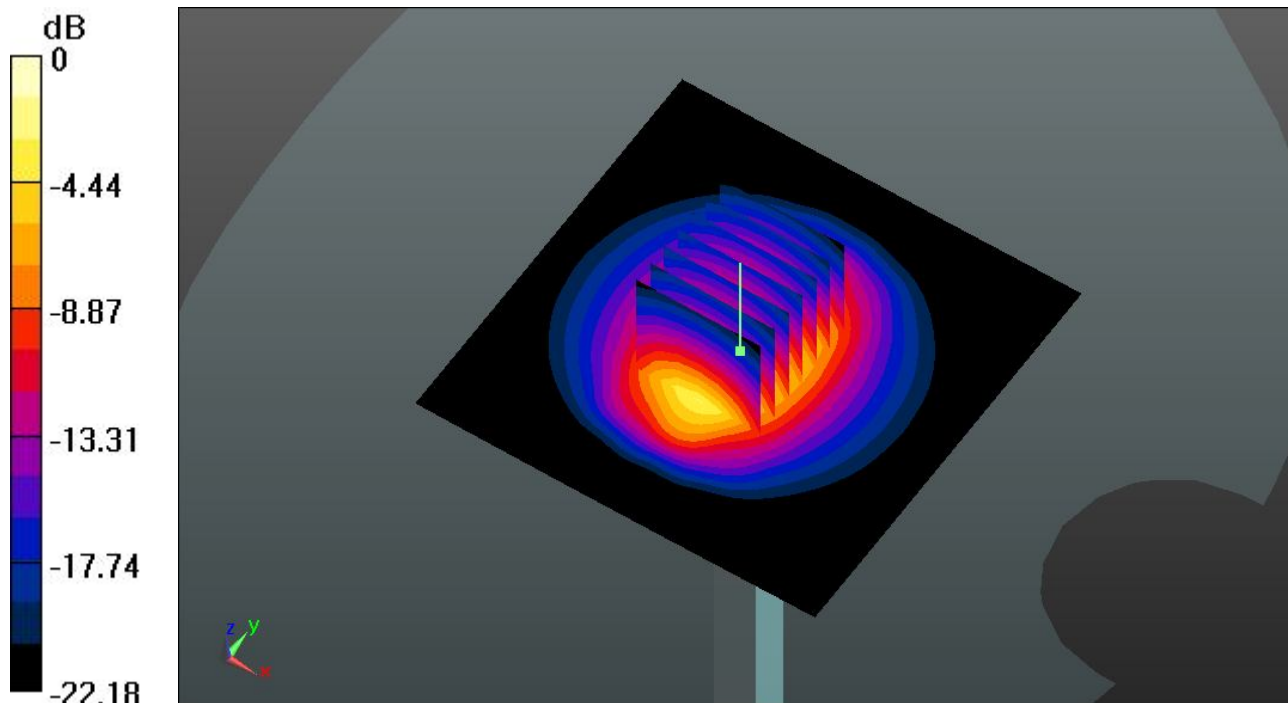

0 dB =  $20.7 \text{ W/kg}$