

FCC RF Test Report

APPLICANT : Brightstar Corporation
EQUIPMENT : mobile phone
BRAND NAME : AVVIO
MODEL NAME : AVVIO 9781
FCC ID : WVBA9781
STANDARD : FCC Part 15 Subpart C §15.247
CLASSIFICATION : (DTS) Digital Transmission System

The product was received on Jan. 30, 2013 and completely tested on Feb 28, 2013. We, SPORTON INTERNATIONAL (KUNSHAN) INC., would like to declare that the tested sample has been evaluated in accordance with the procedures and shown the compliance with the applicable technical standards.

The test results in this report apply exclusively to the tested model / sample. Without written approval of SPORTON INTERNATIONAL (KUNSHAN) INC., the test report shall not be reproduced except in full.

Reviewed by:



Jones Tsai / Manager



SPORTON INTERNATIONAL (KUNSHAN) INC.
No. 3-2, PingXiang Road, Kunshan, Jiangsu Province, P.R.C.



TABLE OF CONTENTS

REVISION HISTORY..... 3

SUMMARY OF TEST RESULT 4

1 GENERAL DESCRIPTION 5

 1.1 Applicant 5

 1.2 Manufacturer 5

 1.3 Feature of Equipment Under Test 5

 1.4 Product Specification of Equipment Under Test..... 5

 1.5 Testing Site 6

 1.6 Applied Standards 6

2 TEST CONFIGURATION OF EQUIPMENT UNDER TEST 7

 2.1 Carrier Frequency Channel 7

 2.2 Pre-Scanned RF Power 8

 2.3 Test Mode 9

 2.4 Connection Diagram of Test System 10

 2.5 Support Unit used in test configuration and system 11

 2.6 RF Utility 11

 2.7 Measurement Results Explanation Example 11

3 TEST RESULT 12

 3.1 6dB Bandwidth Measurement 12

 3.2 Output Power Measurement..... 19

 3.3 Power Spectral Density Measurement 22

 3.4 Conducted Band Edges and Spurious Emission Measurement 34

 3.5 Radiated Emission Measurement..... 47

 3.6 AC Conducted Emission Measurement..... 66

 3.7 Antenna Requirements 70

4 LIST OF MEASURING EQUIPMENT 71

5 UNCERTAINTY OF EVALUATION 72

APPENDIX A. PHOTOGRAPHS OF EUT

APPENDIX B. SETUP PHOTOGRAPHS

SUMMARY OF TEST RESULT

Report Section	FCC Rule	IC Rule	Description	Limit	Result	Remark
3.1	15.247(a)(2)	A8.2(a)	6dB Bandwidth	$\geq 0.5\text{MHz}$	Pass	-
3.2	15.247(b)	A8.4	Power Output Measurement	$\leq 30\text{dBm}$	Pass	-
3.3	15.247(e)	A8.2(b)	Power Spectral Density	$\leq 8\text{dBm}/3\text{kHz}$	Pass	-
3.4	15.247(d)	A8.5	Conducted Band Edges	$\leq 20\text{dBc}$	Pass	-
			Conducted Spurious Emission		Pass	-
3.5	15.247(d)	A8.5	Radiated Band Edges	15.209(a) & 15.247(d)	Pass	-
			Radiated Spurious Emission		Pass	Under limit 3.01 dB at 2389.920 MHz
3.6	15.207	Gen 7.2.4	AC Conducted Emission	15.207(a)	Pass	Under limit 5.09 dB at 0.360 MHz
3.7	15.203 & 15.247(b)	A8.4	Antenna Requirement	N/A	Pass	-



1 General Description

1.1 Applicant

Brightstar Corporation
9725 NW 117th Ave., Miami, Florida, United States

1.2 Manufacturer

LAKIA Networks CO., LTD.
2/F, Unit A, Technology Service Building, Software Garden, 1phase, Xiamen, Fujian, China Zip: 361005

1.3 Feature of Equipment Under Test

Product Feature	
Equipment	mobile phone
Brand Name	AVVIO
Model Name	AVVIO 9781
FCC ID	WVBA9781
EUT supports Radios application	CDMA/EV-DO/WLAN 11bgn/Bluetooth
HW Version	9781_v2.0
SW Version	C9781S-user 2.3.5 GRJ90 eng.root.20130121.052207 test-keys
EUT Stage	Identical Prototype

Remark: The above EUT's information was declared by manufacturer. Please refer to the specifications or user's manual for more detailed description.

1.4 Product Specification of Equipment Under Test

Product Specification subjective to this standard	
Tx/Rx Frequency Range	2412 MHz ~ 2462 MHz
Number of Channels	11
Carrier Frequency of Each Channel	2412+(n-1)*5 MHz; n=1~11
Maximum Output Power to Antenna	802.11b : 14.02 dBm (0.0252 W) 802.11g : 19.11 dBm (0.0815 W) 802.11n HT20 : 19.57 dBm (0.0906 W)
Antenna Type	IFA Antenna type with gain 1.47 dBi
Type of Modulation	802.11b : DSSS (DBPSK / DQPSK / CCK) 802.11g/n : OFDM (BPSK / QPSK / 16QAM / 64QAM)

1.5 Testing Site

Test Site	SPORTON INTERNATIONAL (KUNSHAN) INC.			
Test Site Location	No. 3-2, PingXiang Road, Kunshan, Jiangsu Province, P.R.C. TEL: +86-0512-5790-0158 FAX: +86-0512-5790-0958			
Test Site No.	Sporton Site No.			FCC/IC Registration No.
	TH01-KS	CO01-KS	03CH01-KS	149928/4086E-1

1.6 Applied Standards

According to the specifications of the manufacturer, the EUT must comply with the requirements of the following standards:

- ♦ FCC Part 15 Subpart C §15.247
- ♦ FCC KDB Publication No. 558074 D01 DTS Meas. Guidance v02
- ♦ ANSI C63.4-2003 and ANSI C63.10-2009

Remark:

1. All test items were verified and recorded according to the standards and without any deviation during the test.
2. This EUT has also been tested and complied with the requirements of FCC Part 15, Subpart B, recorded in a separate test report.

2 Test Configuration of Equipment Under Test

The EUT has been associated with peripherals and configuration operated in a manner tended to maximize its emission characteristics in a typical application. Frequency range investigated: conducted emission (150 KHz to 30 MHz) and radiated emission (9 KHz to the 10th harmonic of the highest fundamental frequency or to 40 GHz, whichever is lower). For radiated measurement, pre-scanned in three orthogonal panels, X, Y, Z. The worst cases (Y plane) were recorded in this report.

The final configuration from all the combinations and the worst-case data rates were investigated by measuring the maximum power across all the data rates and modulation modes under section 2.2.

Based on the worst configuration found above, the RF power setting is set individually to meet FCC compliance limit for the final conducted and radiated tests shown in section 2.3.

2.1 Carrier Frequency Channel

Frequency Band	Channel	Freq. (MHz)	Channel	Freq. (MHz)
2400-2483.5 MHz	1	2412	7	2442
	2	2417	8	2447
	3	2422	9	2452
	4	2427	10	2457
	5	2432	11	2462
	6	2437		

2.2 Pre-Scanned RF Power

Preliminary tests were performed in different data rate and antenna configurations as following table and the highest power data rates were chosen for full test in the following tables. Final Output Power equals to Measured Output Power adds the duty factor.

Channel	Frequency	2.4GHz 802.11b RF Power (dBm)			
		DSSS Data Rate			
		1 Mbps	2 Mbps	5.5 Mbps	11 Mbps
CH 01	2412 MHz	13.69	13.85	13.86	13.87
CH 06	2437 MHz	13.85	13.87	13.9	13.92
CH 11	2462 MHz	13.93	14.01	14.02	14.01

Channel	Frequency	2.4GHz 802.11g RF Power (dBm)							
		OFDM Data Rate							
		6 Mbps	9 Mbps	12 Mbps	18 Mbps	24 Mbps	36 Mbps	48 Mbps	54 Mbps
CH 01	2412 MHz	17.88	17.61	17.97	17.38	18.86	18.74	18.87	19.11
CH 06	2437 MHz	18.4	18.04	18.25	17.94	18.61	18.52	18.32	18.41
CH 11	2462 MHz	18.19	18.02	18.01	17.76	18.35	18.25	18.1	17.96

Channel	Frequency	2.4GHz 802.11n HT20 RF Power (dBm)							
		OFDM Data Rate							
		MCS0	MCS1	MCS2	MCS3	MCS4	MCS5	MCS6	MCS7
CH 01	2412 MHz	17.74	17.72	17.86	18.63	18.69	19.57	19.01	19.11
CH 06	2437 MHz	18.18	17.95	18.37	18.07	18.02	18.47	18.97	18.23
CH 11	2462 MHz	17.98	17.71	18.07	17.84	18.04	18.12	18.64	17.85

2.3 Test Mode

Final results of test modes, data rates and test channels are shown as following table.

Test Cases				
	Test Items	Mode	Data Rate	Test Channel
Conducted TCs	6dB BW Power Spectral Density	802.11b	5.5 Mbps	1/6/11
		802.11g	54 Mbps	1/6/11
		802.11n HT20	52 Mbps	1/6/11
	Output Power	802.11b	5.5 Mbps	1/6/11
		802.11g	54 Mbps	1/6/11
		802.11n HT20	52 Mbps	1/6/11
	Conducted Band Edge	802.11b	5.5 Mbps	1/11
		802.11g	54 Mbps	1/11
		802.11n HT20	52 Mbps	1/11
	Conducted Spurious Emission	802.11b	5.5 Mbps	1/6/11
		802.11g	54 Mbps	1/6/11
		802.11n HT20	52 Mbps	1/6/11
Radiated TCs	Radiated Band Edge	802.11b	5.5 Mbps	1/11
		802.11g	54 Mbps	1/11
		802.11n HT20	52 Mbps	1/11
	Radiated Spurious Emission	802.11b	5.5 Mbps	1/6/11
		802.11g	54 Mbps	1/6/11
		802.11n HT20	52 Mbps	1/6/11
AC Conducted Emission	Mode 1 : CDMA2000 BC0 Idle + Bluetooth Link + WLAN Link + USB Cable (Charging from Adapter) + Earphone			

2.4 Connection Diagram of Test System

<WLAN Tx Mode>

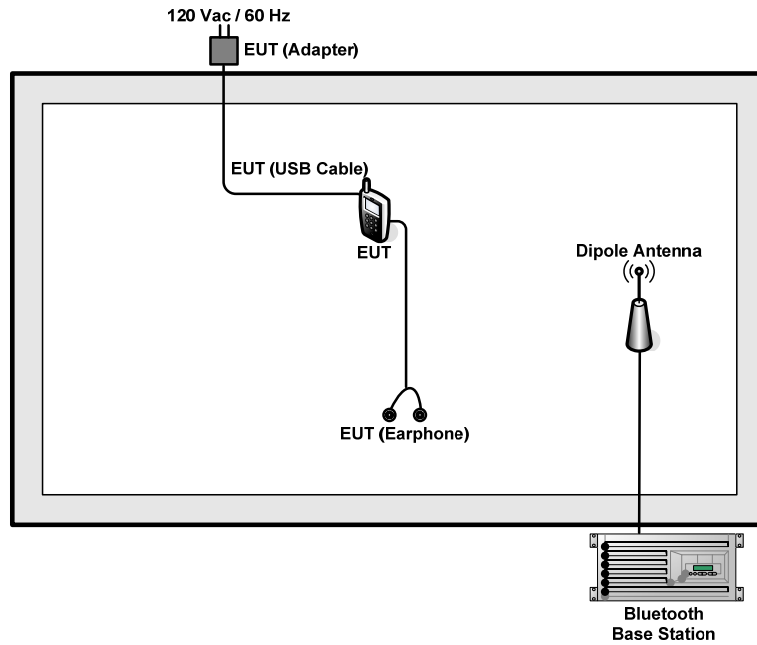

<AC Conducted Emission Mode>

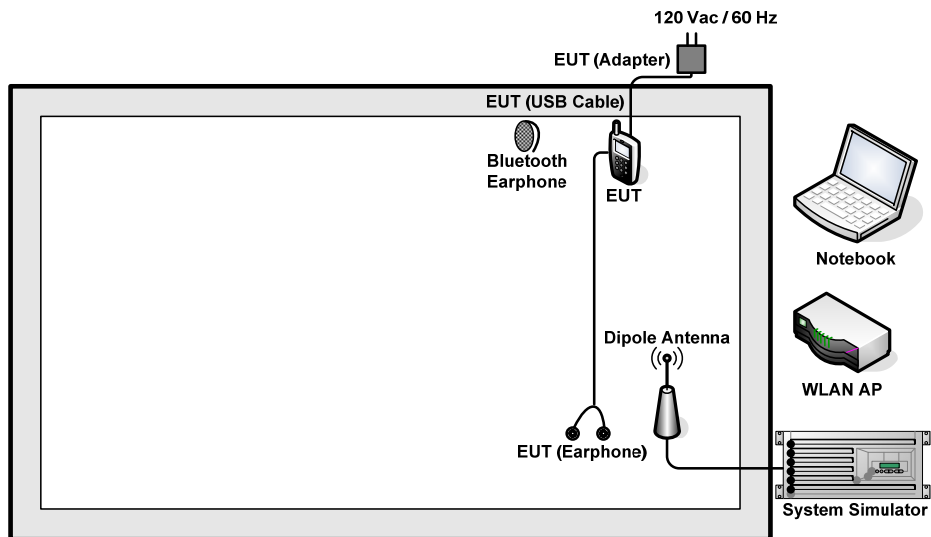

2.5 Support Unit used in test configuration and system

Item	Equipment	Trade Name	Model Name	FCC ID	Data Cable	Power Cord
1.	System Simulator	R&S	CMU 200	N/A	N/A	Unshielded, 1.8 m
2.	DC Power Supply	GWINSTEK	GPS-3030D	N/A	N/A	Unshielded, 1.8 m
3.	WLAN AP	D-Link	DIR-855	KA2DIR855A2	N/A	Unshielded, 1.8 m
4.	Notebook	DELL	P08S	QDS-BRCM1030	N/A	AC I/P: Unshielded, 0.9 m DC O/P: Shielded, 1.8 m
5.	Bluetooth Earphone	Nokia	BH-106	QTLBH-106	N/A	N/A

2.6 RF Utility

For WLAN function, programmed RF utility, “ADB” in EUT directly. Then, the EUT will get into the engineering modes to contact with WLAN AP for continuous transmitting and receiving signals.

2.7 Measurement Results Explanation Example

For conducted test items:

The offset level is set in the spectrum analyzer to compensate the RF cable loss and 10dB attenuator between EUT conducted output port and spectrum analyzer. With the offset compensation, the spectrum analyzer reading level is exactly the EUT RF output level.

The spectrum analyzer offset is derived from RF cable loss and 10dB attenuator factor.

Offset = RF cable loss + attenuator factor.

Following table shows an offset computation example with cable loss 5.6 dB.

Example :

$$\begin{aligned} \text{Offset(dB)} &= \text{RF cable loss(dB)} + \text{attenuator factor(dB)}. \\ &= 5.6 + 10 = 15.6 \text{ (dB)} \end{aligned}$$

3 Test Result

3.1 6dB Bandwidth Measurement

3.1.1 Limit of 6dB Bandwidth

The minimum 6 dB bandwidth shall be at least 500 KHz.

3.1.2 Measuring Instruments

See list of measuring instruments of this test report.

3.1.3 Test Procedures

1. The testing follows the Measurement Procedure of FCC KDB No. 558074 DTS D01 Meas. Guidance v02.
2. The RF output of EUT was connected to the spectrum analyzer by RF cable and attenuator. The path loss was compensated to the results for each measurement.
3. Set to the maximum power setting and enable the EUT transmit continuously.
4. Make the measurement with the spectrum analyzer's resolution bandwidth (RBW) = 100 kHz. Set the Video bandwidth (VBW) = 300 kHz. In order to make an accurate measurement. The 6 dB bandwidth must be greater than 500 KHz.
5. Measure and record the results in the test report.

3.1.4 Test Setup

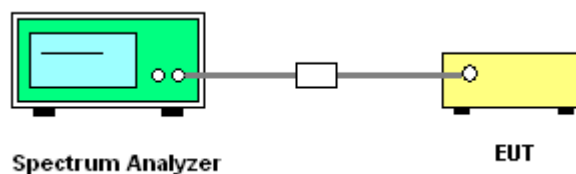

3.1.5 Test Result of 6dB Bandwidth

Test Mode :	802.11b	Temperature :	20~21°C
Test Engineer :	Zhi Lu	Relative Humidity :	40~41%

Channel	Frequency (MHz)	802.11b 6dB Bandwidth (MHz)	6dB Bandwidth Min. Limit (MHz)	Pass/Fail
01	2412	10.00	0.5	Pass
06	2437	10.00	0.5	Pass
11	2462	10.30	0.5	Pass

6 dB Bandwidth Plot on 802.11b Channel 01

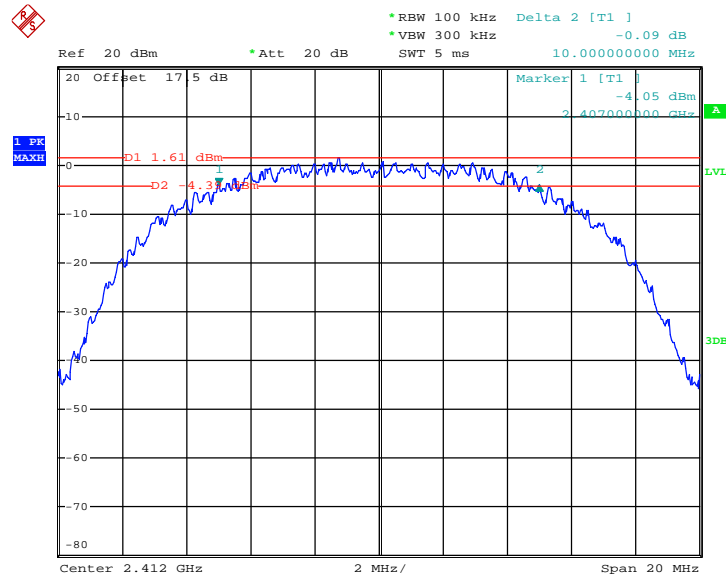

Date: 22.FEB.2013 17:31:06



6 dB Bandwidth Plot on 802.11b Channel 06

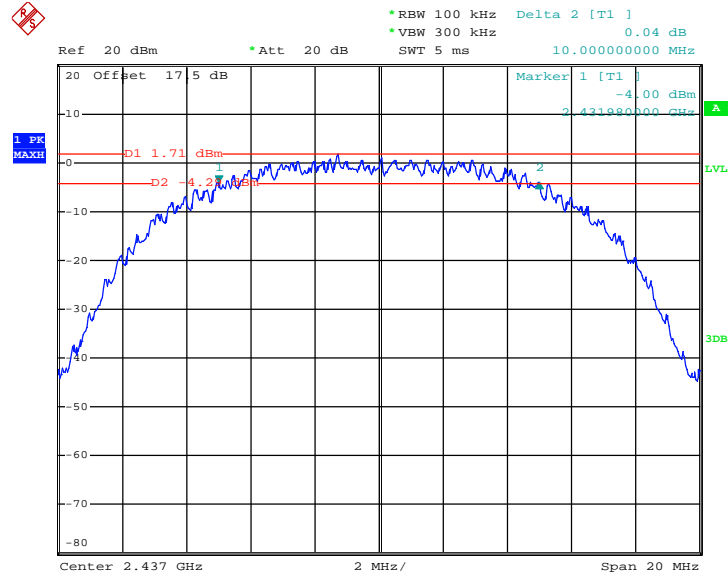

Date: 22.FEB.2013 14:24:00

6 dB Bandwidth Plot on 802.11b Channel 11

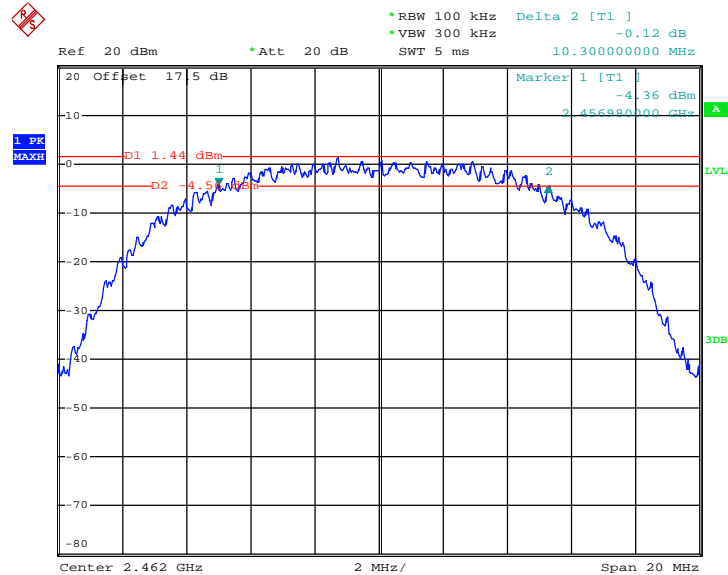

Date: 22.FEB.2013 14:27:20



Test Mode :	802.11g	Temperature :	20~21°C
Test Engineer :	Zhi Lu	Relative Humidity :	40~41%

Channel	Frequency (MHz)	802.11g 6dB Bandwidth (MHz)	6dB Bandwidth Min. Limit (MHz)	Pass/Fail
01	2412	16.46	0.5	Pass
06	2437	16.44	0.5	Pass
11	2462	16.48	0.5	Pass

6 dB Bandwidth Plot on 802.11g Channel 01

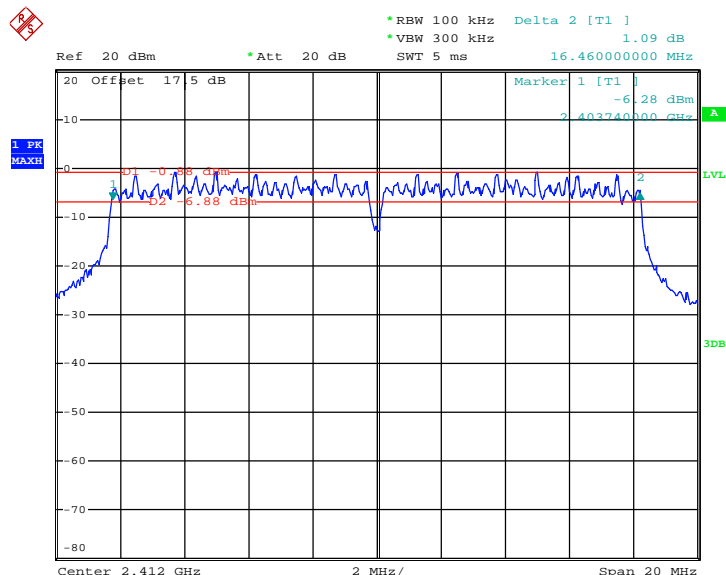

Date: 22.FEB.2013 14:30:52



6 dB Bandwidth Plot on 802.11g Channel 06

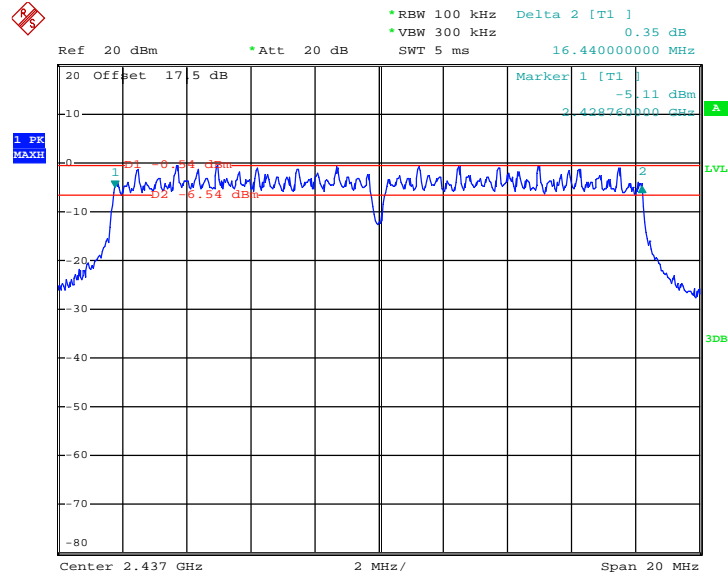

Date: 22.FEB.2013 14:34:50

6 dB Bandwidth Plot on 802.11g Channel 11

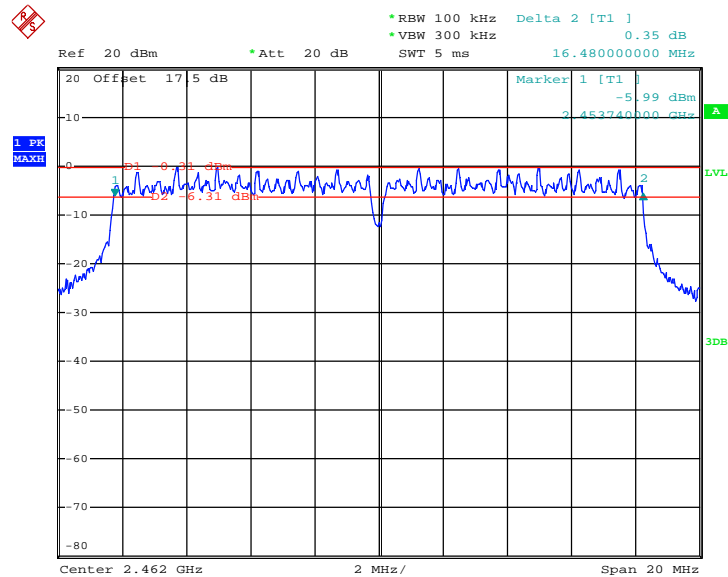

Date: 22.FEB.2013 14:37:29



Test Mode :	802.11n HT20	Temperature :	20~21°C
Test Engineer :	Zhi Lu	Relative Humidity :	40~41%

Channel	Frequency (MHz)	2.4GHz 802.11n HT20 6dB Bandwidth (MHz)	6dB Bandwidth Min. Limit (MHz)	Pass/Fail
01	2412	17.64	0.5	Pass
06	2437	17.64	0.5	Pass
11	2462	17.64	0.5	Pass

6 dB Bandwidth Plot on 802.11n HT20 Channel 01

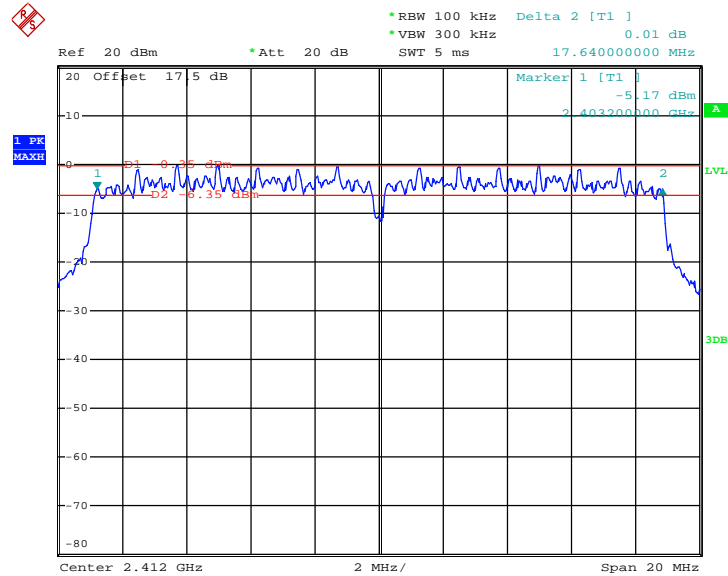

Date: 22.FEB.2013 14:40:48



6 dB Bandwidth Plot on 802.11n HT20 Channel 06

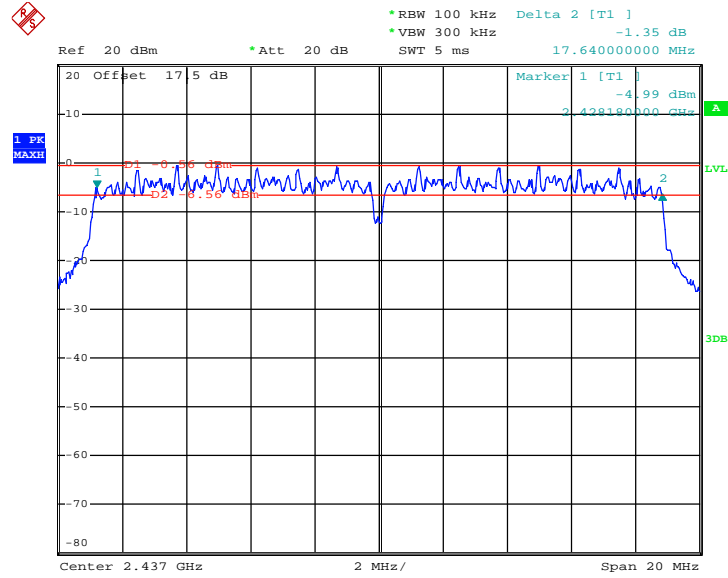

Date: 22.FEB.2013 14:44:10

6 dB Bandwidth Plot on 802.11n HT20 Channel 11

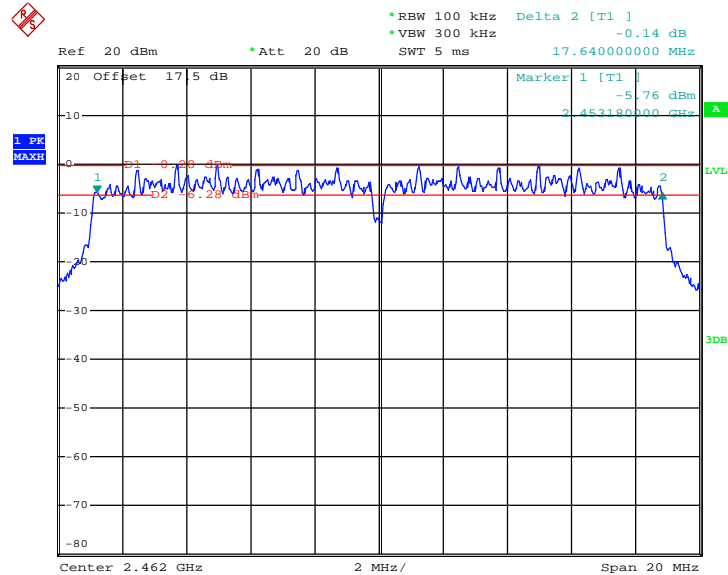

Date: 22.FEB.2013 14:46:33

3.2 Output Power Measurement

3.2.1 Limit of Output Power

For systems using digital modulation in the 2400-2483.5MHz, the limit for peak output power is 30dBm. If transmitting antenna of directional gain greater than 6dBi are used the peak output power from the intentional radiator shall be reduced below the above stated value by the amount in dB that the directional gain of the antenna exceeds 6 dBi. In case of point-to-point operation, the limit has to be reduced by 1dB for every 3dB that the directional gain of the antenna exceeds 6dBi.

3.2.2 Measuring Instruments

See list of measuring instruments of this test report.

3.2.3 Test Procedures

1. The testing follows the Measurement Procedure of FCC KDB No. 558074 DTS D01 Meas. Guidance v02.
2. The RF output of EUT was connected to the spectrum analyzer by RF cable and attenuator. The path loss was compensated to the results for each measurement.
3. Set to the maximum power setting and enable the EUT transmit continuously.
4. Measure the conducted output power and record the results in the test report.

3.2.4 Test Setup

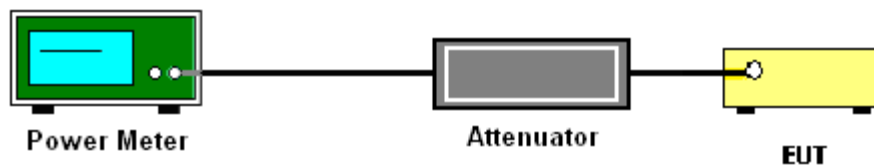

3.2.5 Test Result of Peak Output Power

Test Mode :	802.11b	Temperature :	20~21°C
Test Engineer :	Zhi Lu	Relative Humidity :	40~41%

Channel	Frequency (MHz)	802.11b Peak Output Power (dBm)	Max. Limits (dBm)	Pass/Fail
01	2412	13.86	30	Pass
06	2437	13.9	30	Pass
11	2462	14.02	30	Pass

Test Mode :	802.11g	Temperature :	20~21°C
Test Engineer :	Zhi Lu	Relative Humidity :	40~41%

Channel	Frequency (MHz)	802.11g Peak Output Power (dBm)	Max. Limits (dBm)	Pass/Fail
01	2412	19.11	30	Pass
06	2437	18.41	30	Pass
11	2462	17.96	30	Pass

Test Mode :	802.11n HT20	Temperature :	20~21°C
Test Engineer :	Zhi Lu	Relative Humidity :	40~41%

Channel	Frequency (MHz)	2.4GHz 802.11n HT20 Peak Output Power (dBm)	Max. Limits (dBm)	Pass/Fail
01	2412	19.57	30	Pass
06	2437	18.47	30	Pass
11	2462	18.12	30	Pass



3.2.6 Test Result of Average output Power (Reporting Only)

Test Mode :	802.11b	Temperature :	20~21°C
Test Engineer :	Zhi Lu	Relative Humidity :	40~41%
Duty Cycle:	98.53%	Duty Factor:	0.06dB

Channel	Frequency (MHz)	802.11b Average Output Power (dBm)
01	2412	11.38
06	2437	11.47
11	2462	11.67

Test Mode :	802.11g	Temperature :	20~21°C
Test Engineer :	Zhi Lu	Relative Humidity :	40~41%
Duty Cycle:	95.15%	Duty Factor:	0.22dB

Channel	Frequency (MHz)	802.11g Average Output Power (dBm)
01	2412	8.58
06	2437	9.38
11	2462	9.65

Test Mode :	802.11n HT20	Temperature :	20~21°C
Test Engineer :	Zhi Lu	Relative Humidity :	40~41%
Duty Cycle:	95.42%	Duty Factor:	0.20dB

Channel	Frequency (MHz)	802.11n HT20 Average Output Power (dBm)
01	2412	8.49
06	2437	9.31
11	2462	9.57

3.3 Power Spectral Density Measurement

3.3.1 Limit of Power Spectral Density

The peak power spectral density shall not be greater than 8dBm in any 3KHz band at any time interval of continuous transmission.

3.3.2 Measuring Instruments

See list of measuring instruments of this test report.

3.3.3 Test Procedures

1. The testing follows Measurement Procedure 9.1 Option 1 of FCC KDB Publication No. 558074 D01 DTS Meas. Guidance v02
2. The RF output of EUT was connected to the spectrum analyzer by RF cable and attenuator. The path loss was compensated to the results for each measurement.
3. Set to the maximum power setting and enable the EUT transmit continuously.
4. Make the measurement with the spectrum analyzer's resolution bandwidth (RBW) = 3 kHz. Video bandwidth VBW = 10 kHz In order to make an accurate measurement, set the span to 1.5 times DTS Channel Bandwidth. (6dB BW)
5. Detector = peak, Sweep time = auto couple, Trace mode = max hold, Allow trace to fully stabilize. Use the peak marker function to determine the maximum power level.
6. Measure and record the results in the test report.

3.3.4 Test Setup

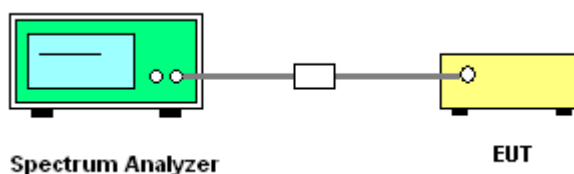

3.3.5 Test Result of Power Spectral Density

Test Mode :	802.11b	Temperature :	20~21°C
Test Engineer :	Zhi Lu	Relative Humidity :	40~41%

Channel	Frequency (MHz)	802.11b Power Density		Max. Limits (dBm/3KHz)	Pass/Fail
		PSD/100KHz (dBm)	PSD/3KHz (dBm)		
01	2412	0.40	-12.89	8	Pass
06	2437	1.39	-12.74	8	Pass
11	2462	0.99	-12.73	8	Pass

Test Mode :	802.11g	Temperature :	20~21°C
Test Engineer :	Zhi Lu	Relative Humidity :	40~41%

Channel	Frequency (MHz)	802.11g Power Density		Max. Limits (dBm/3KHz)	Pass/Fail
		PSD/100KHz (dBm)	PSD/3KHz (dBm)		
01	2412	-0.92	-15.64	8	Pass
06	2437	-0.63	-14.38	8	Pass
11	2462	-0.39	-15.08	8	Pass

Test Mode :	802.11n HT20	Temperature :	20~21°C
Test Engineer :	Zhi Lu	Relative Humidity :	40~41%

Channel	Frequency (MHz)	802.11n HT20 Power Density		Max. Limits (dBm/3KHz)	Pass/Fail
		PSD/100KHz (dBm)	PSD/3KHz (dBm)		
01	2412	-0.39	-14.11	8	Pass
06	2437	-0.60	-14.92	8	Pass
11	2462	-0.28	-15.15	8	Pass

Note:

1. Measured power density (dBm) has offset with cable loss.
2. The Measured power density (dBm)/ 100KHz is reference level and used as 20dBc down for Conducted Band Edges and Conducted Spurious Emission limit line.



3.3.6 Test Result of Power Spectral Density Plots (100kHz)

PSD 100kHz Plot on 802.11b Channel 01

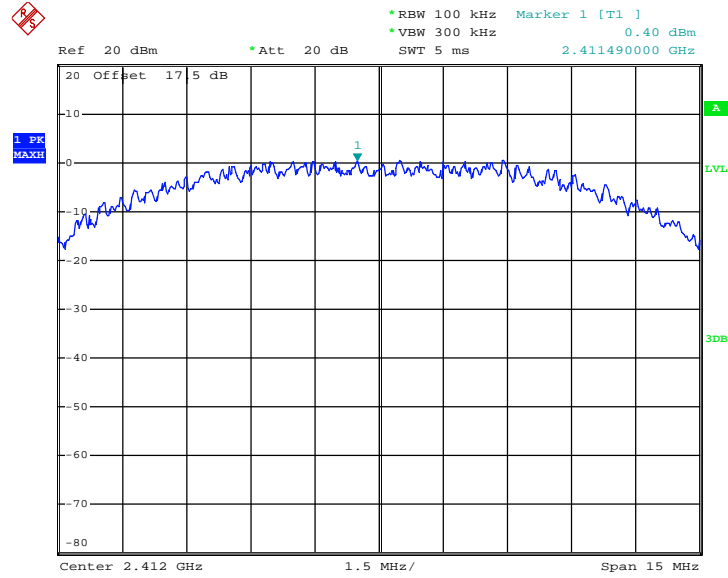

Date: 22.FEB.2013 17:31:46

PSD 100kHz Plot on 802.11b Channel 06

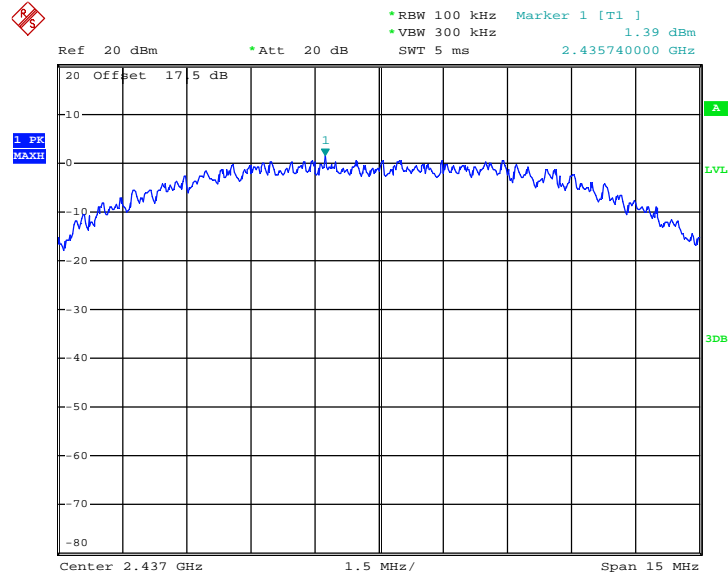

Date: 22.FEB.2013 14:24:50



PSD 100kHz Plot on 802.11b Channel 11

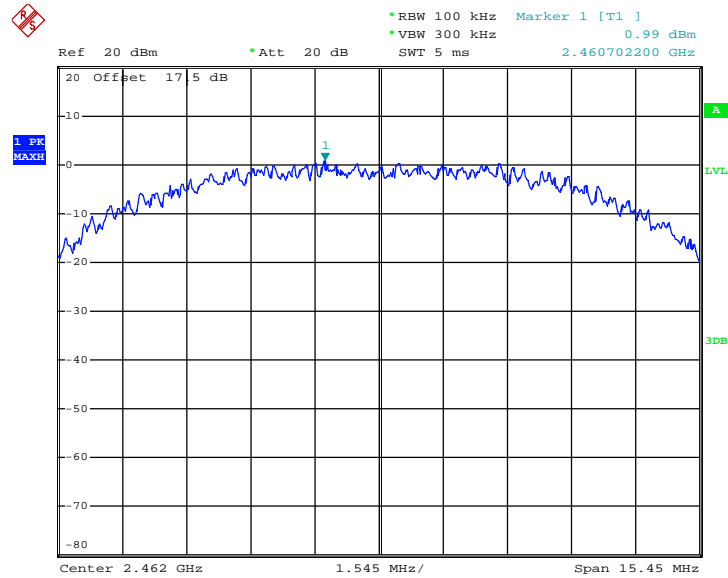

Date: 22.FEB.2013 14:27:58

PSD 100kHz Plot on 802.11g Channel 01

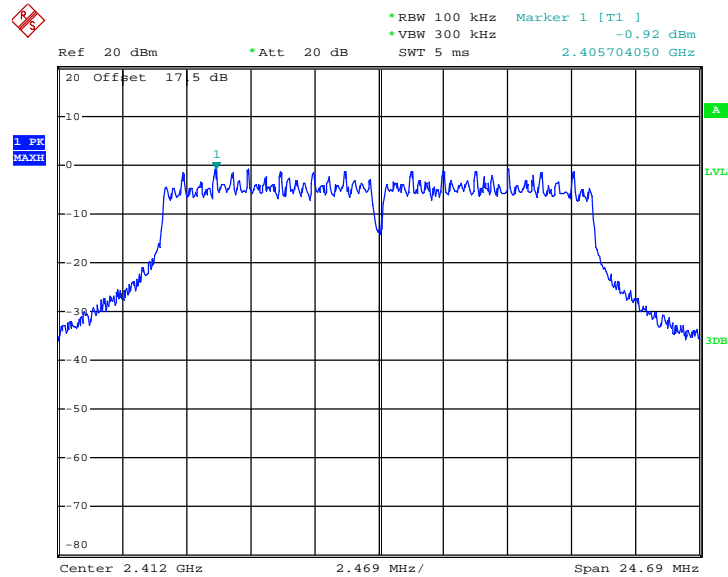

Date: 22.FEB.2013 14:31:30



PSD 100kHz Plot on 802.11g Channel 06

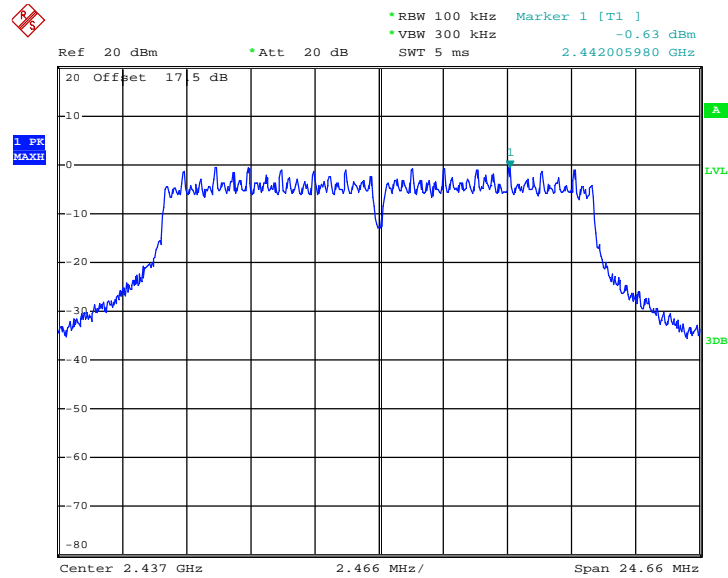

Date: 22.FEB.2013 14:35:28

PSD 100kHz Plot on 802.11g Channel 11

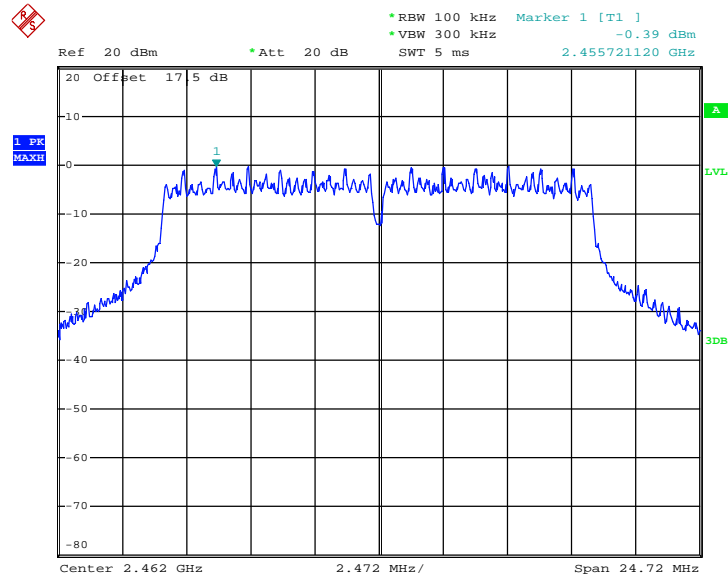

Date: 22.FEB.2013 14:38:09



PSD 100kHz Plot on 802.11n HT20 Channel 01

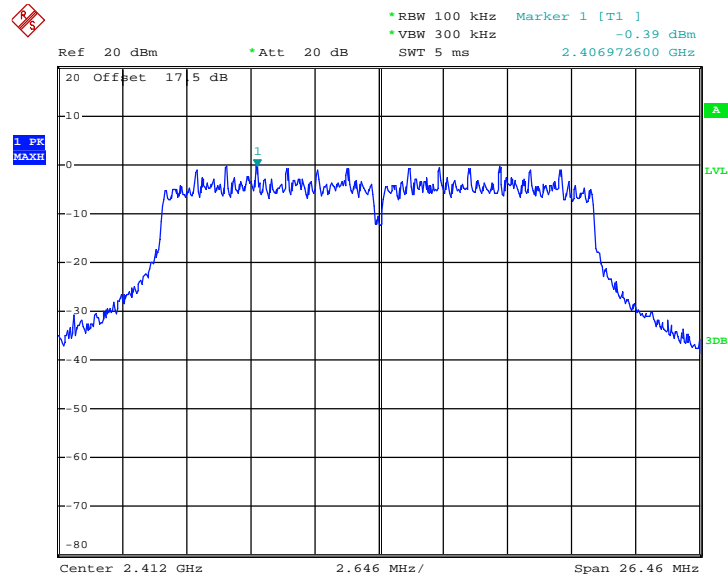

Date: 22.FEB.2013 14:42:00

PSD 100kHz Plot on 802.11n HT20 Channel 06

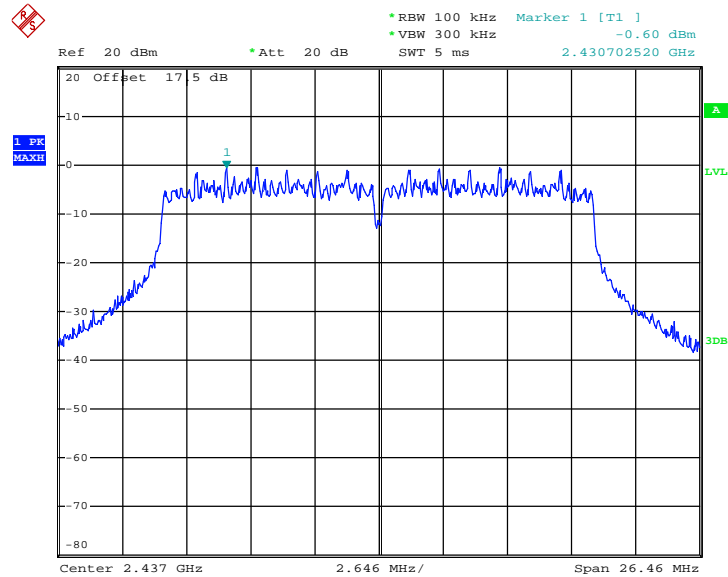

Date: 22.FEB.2013 14:44:46



PSD 100kHz Plot on 802.11n HT20 Channel 11

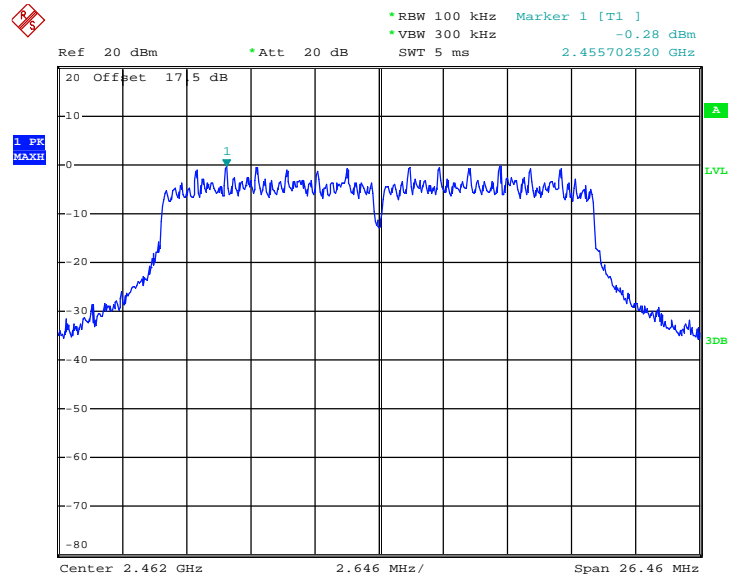

Date: 22.FEB.2013 14:47:10



3.3.7 Test Result of Power Spectral Density Plots (3kHz)

PSD 3kHz Plot on 802.11b Channel 01

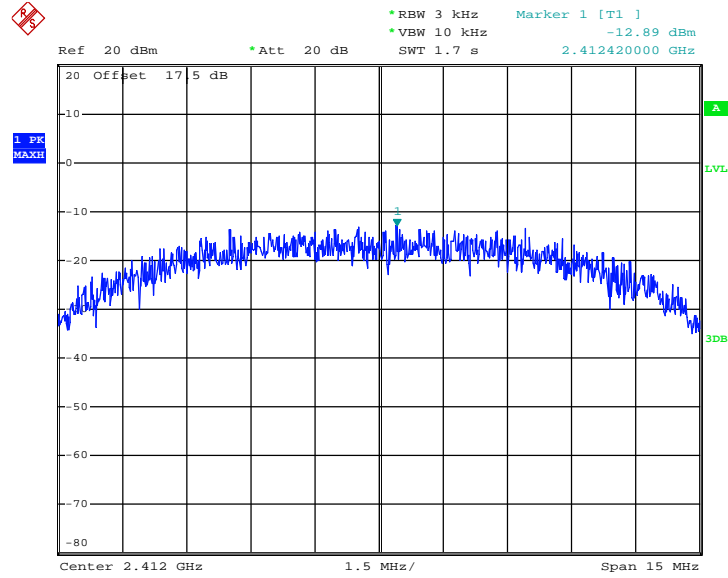

Date: 22.FEB.2013 17:31:33

PSD 3kHz Plot on 802.11b Channel 06

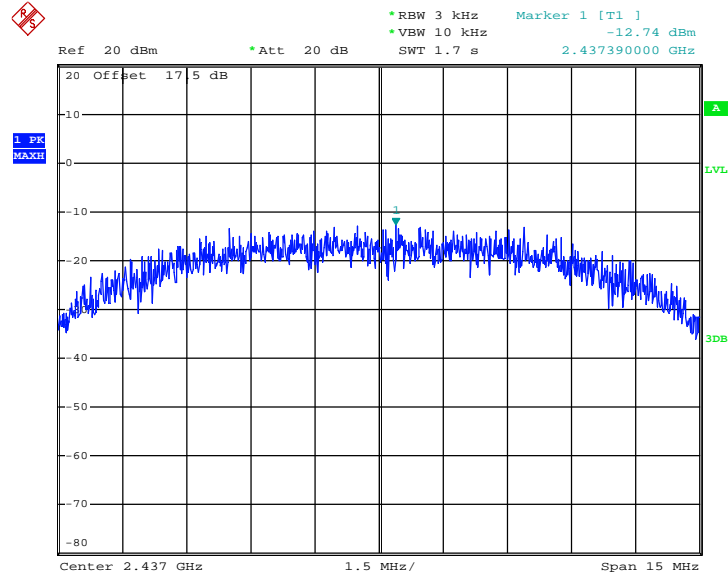

Date: 22.FEB.2013 14:24:27



PSD 3kHz Plot on 802.11b Channel 11

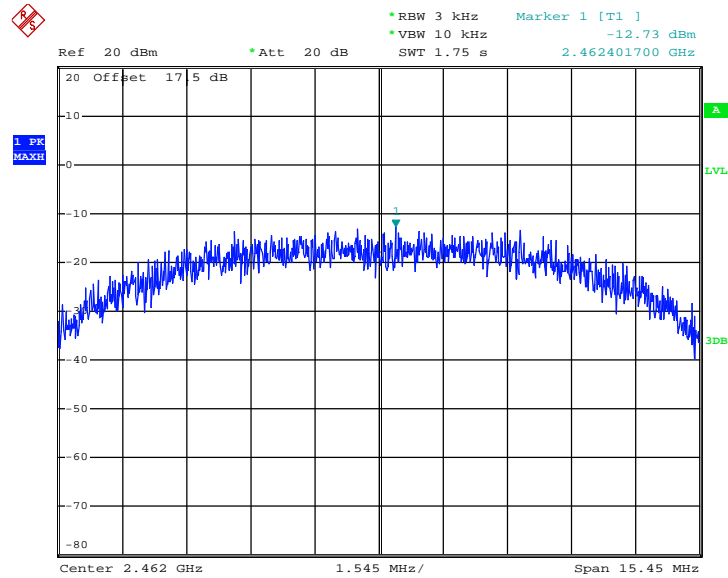

Date: 22.FEB.2013 14:27:45

PSD 3kHz Plot on 802.11g Channel 01

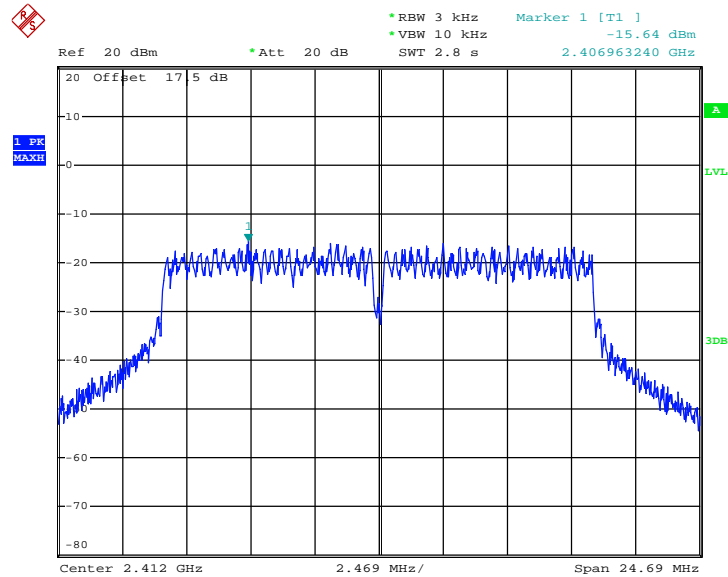

Date: 22.FEB.2013 14:31:18



PSD 3kHz Plot on 802.11g Channel 06

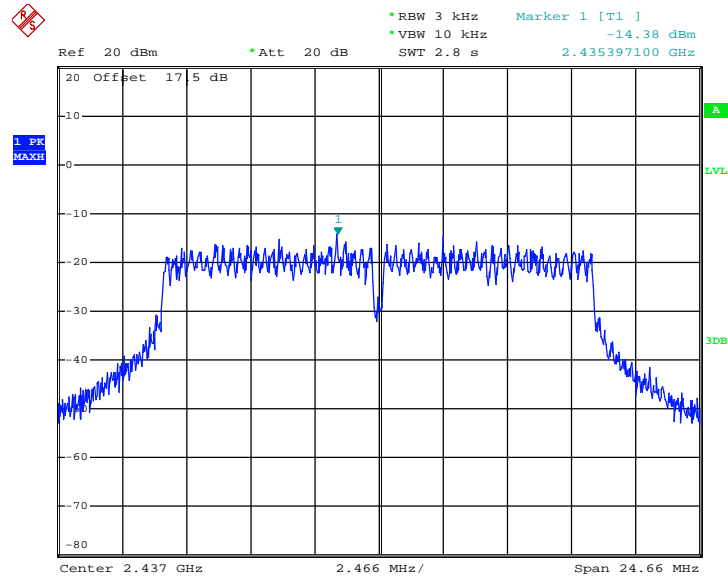

Date: 22.FEB.2013 14:35:16

PSD 3kHz Plot on 802.11g Channel 11

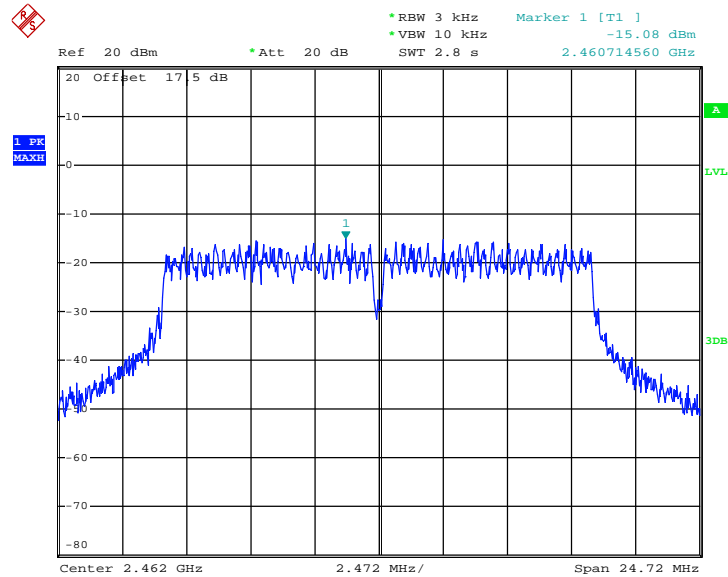

Date: 22.FEB.2013 14:37:53



PSD 3kHz Plot on 802.11n HT20 Channel 01

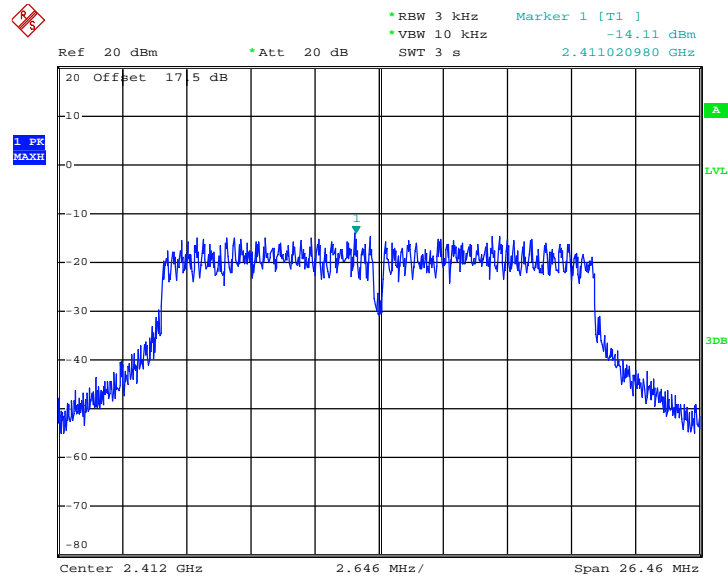

Date: 22.FEB.2013 14:41:17

PSD 3kHz Plot on 802.11n HT20 Channel 06

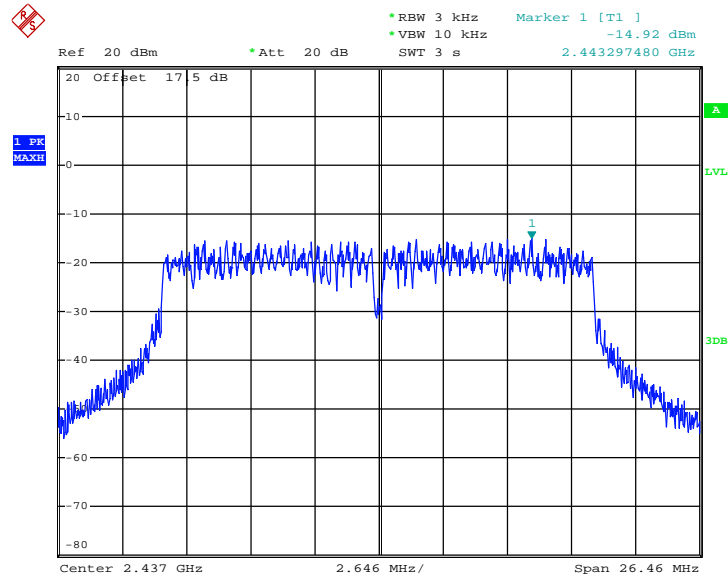

Date: 22.FEB.2013 14:44:33



PSD 3kHz Plot on 802.11n HT20 Channel 11

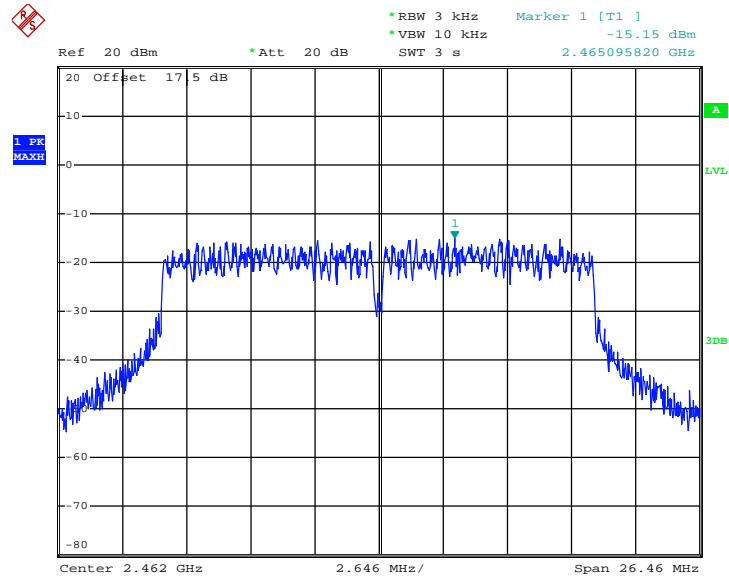

Date: 22.FEB.2013 14:46:57

3.4 Conducted Band Edges and Spurious Emission Measurement

3.4.1 Limit of Conducted Band Edges and Spurious Emission Measurement

In any 100 kHz bandwidth outside of the authorized frequency band, the emissions which fall in the non-restricted bands shall be attenuated at least 20 dB / 30dB relative to the maximum PSD level in 100 kHz by RF conducted measurement and radiated emissions which fall in the restricted bands, as defined in Section 15.205(a), must also comply with the radiated emission limits specified in Section 15.209(a).

3.4.2 Measuring Instruments

See list of measuring instruments of this test report.

3.4.3 Test Procedures

1. The testing follows the Measurement Procedure of FCC KDB No. 558074 DTS D01 Meas. Guidance v02.
2. The RF output of EUT was connected to the spectrum analyzer by RF cable and attenuator. The path loss was compensated to the results for each measurement.
3. Set to the maximum power setting and enable the EUT transmit continuously.
4. Set RBW = 100 KHz, VBW=300 KHz, Peak Detector. Unwanted Emissions measured in any 100 kHz bandwidth outside of the authorized frequency band shall be attenuated by at least 20 dB relative to the maximum in-band peak PSD level in 100 kHz, when maximum peak conducted output power procedure is used. The attenuation is set to 30dB, when maximum conducted output power procedure is used.
5. Measure and record the results in the test report.

3.4.4 Test Setup

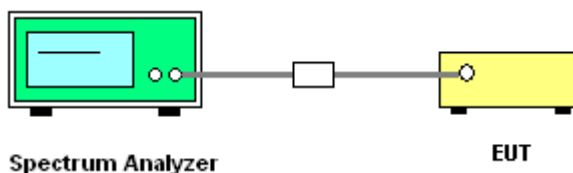

3.4.5 Test Plots of Conducted Band Edges

Test Mode :	802.11b	Temperature :	20~21°C
Test Band :	Low and High	Relative Humidity :	40~41%
Test Channel :	01 and 11	Test Engineer :	Zhi Lu

Low Band Edge Plot on 802.11b Channel 01

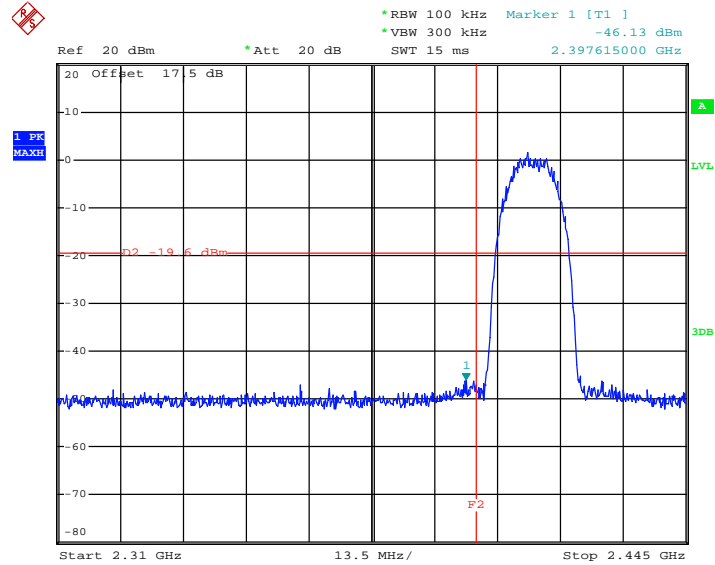

Date: 22.FEB.2013 17:32:23

High Band Edge Plot on 802.11b Channel 11

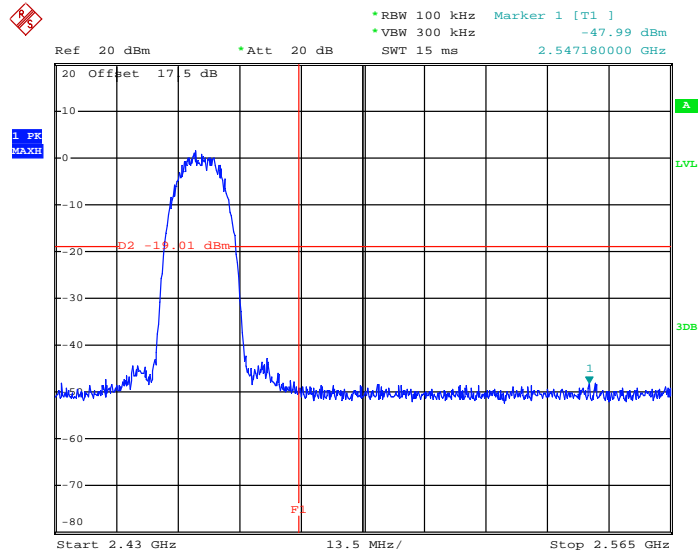

Date: 22.FEB.2013 14:28:16



Test Mode :	802.11g	Temperature :	20~21°C
Test Band :	Low and High	Relative Humidity :	40~41%
Test Channel :	01 and 11	Test Engineer :	Zhi Lu

Low Band Edge Plot on 802.11g Channel 01

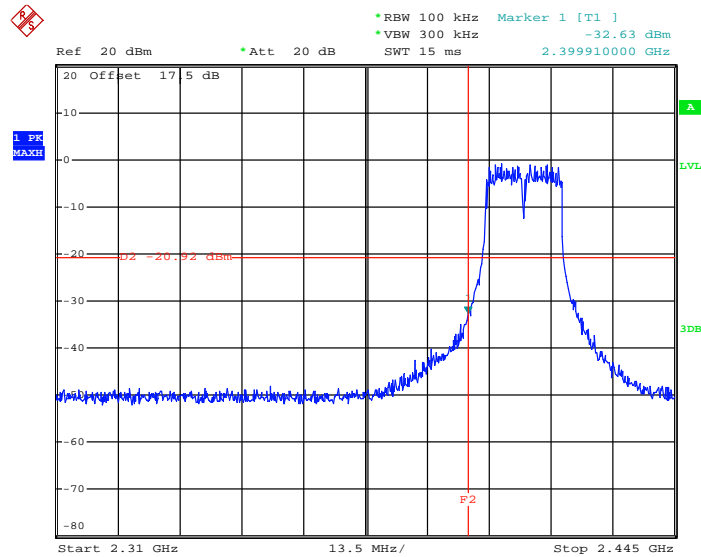

Date: 22.FEB.2013 14:31:53

High Band Edge Plot on 802.11g Channel 11

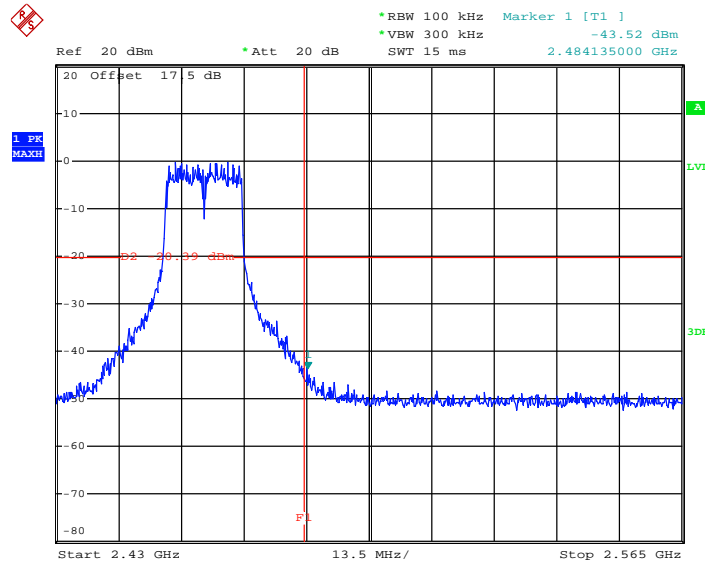

Date: 22.FEB.2013 14:38:27



Test Mode :	802.11n HT20	Temperature :	20~21°C
Test Band :	Low and High	Relative Humidity :	40~41%
Test Channel :	01 and 11	Test Engineer :	Zhi Lu

Low Band Edge Plot on 802.11n HT20 Channel 01

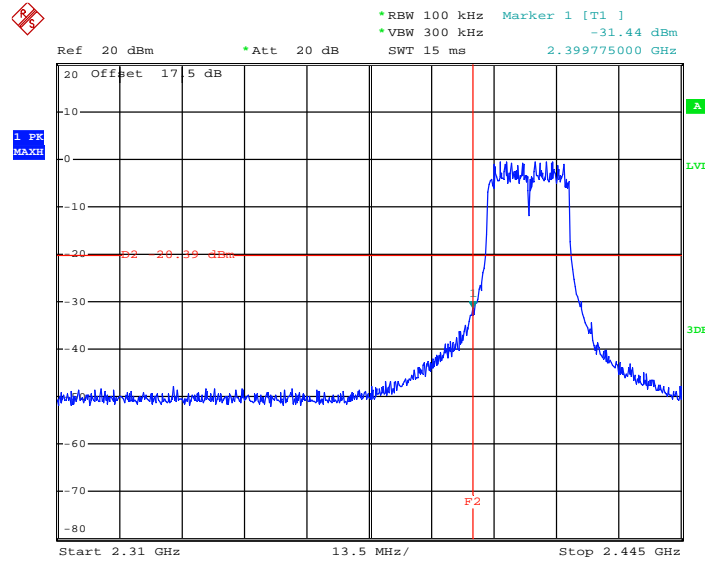

Date: 22.FEB.2013 14:42:19

High Band Edge Plot on 802.11n HT20 Channel 11

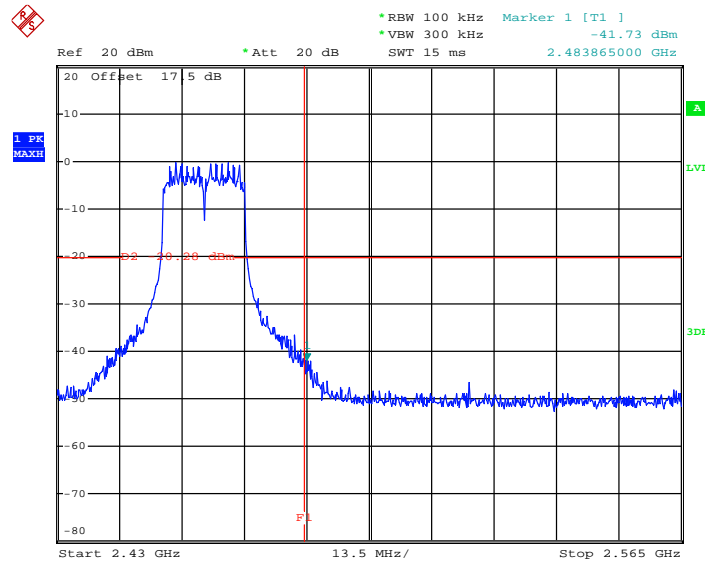

Date: 22.FEB.2013 14:47:29

3.4.6 Test Plots of Spurious Emission

Test Mode :	802.11b	Temperature :	20~21°C
Test Band :	30MHz-3GHz and 2G-25GHz	Relative Humidity :	40~41%
Test Channel :	01, 06, 11	Test Engineer :	Zhi Lu

802.11b 30 MHz~3 GHz

Conducted Spurious Emission Plot on Channel 01

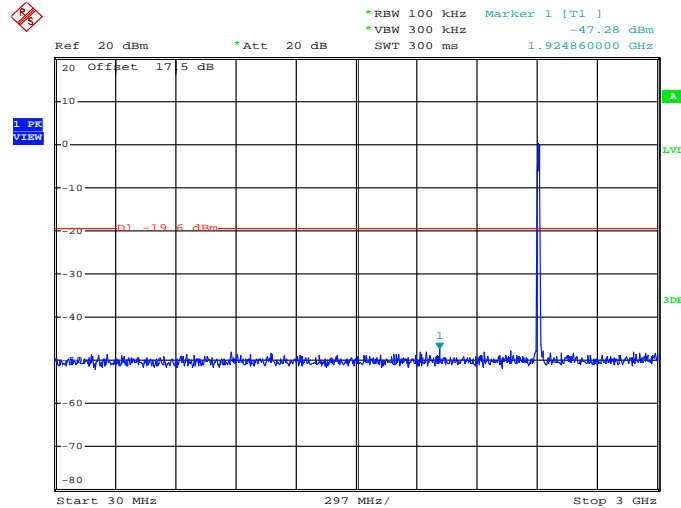

Date: 22.FEB.2013 17:32:46

802.11b 2 GHz~25 GHz

Conducted Spurious Emission Plot on Channel 01

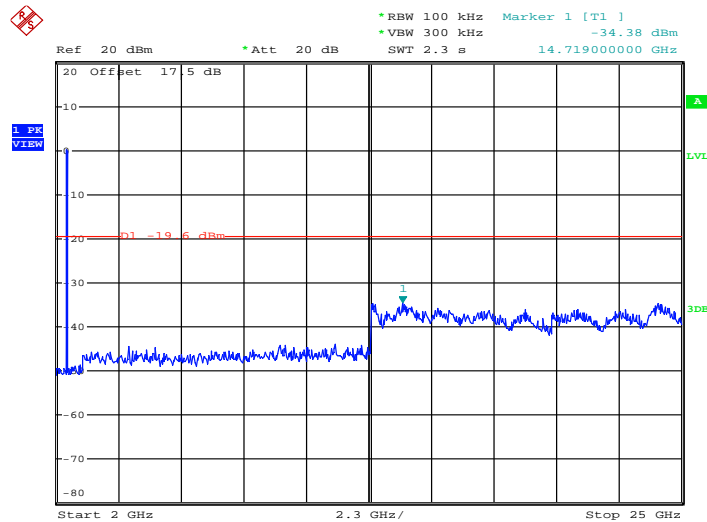

Date: 22.FEB.2013 17:33:04



802.11b 30 MHz~3 GHz

Conducted Spurious Emission Plot on Channel 06

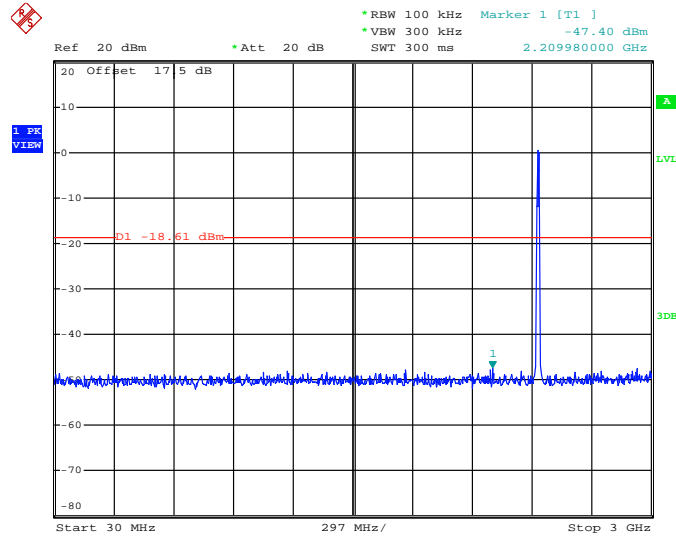

Date: 22.FEB.2013 14:25:15

802.11b 2 GHz~25 GHz

Conducted Spurious Emission Plot on Channel 06

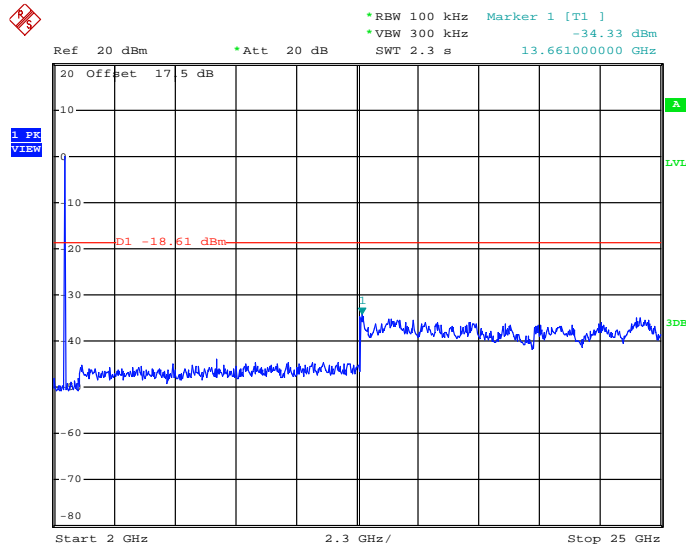

Date: 22.FEB.2013 14:25:34



802.11b 30 MHz~3 GHz

Conducted Spurious Emission Plot on Channel 11

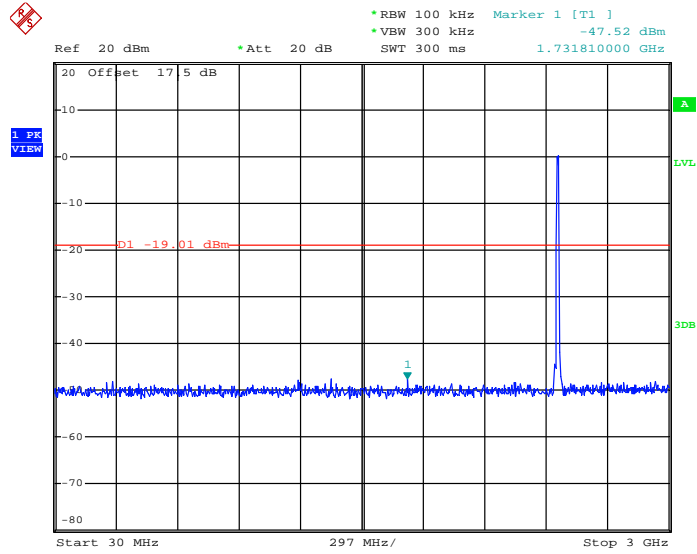

Date: 22.FEB.2013 14:28:39

802.11b 2 GHz~25 GHz

Conducted Spurious Emission Plot on Channel 11

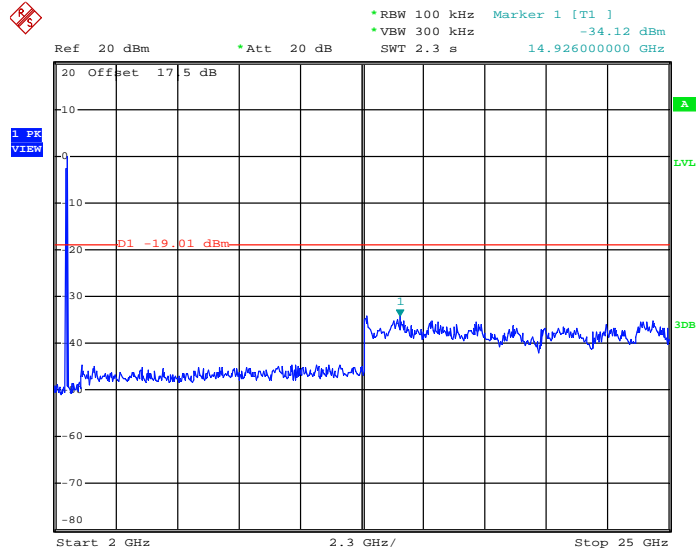

Date: 22.FEB.2013 14:28:58



Test Mode :	802.11g	Temperature :	20~21°C
Test Band :	30MHz-3GHz and 2G-25GHz	Relative Humidity :	40~41%
Test Channel :	01, 06, 11	Test Engineer :	Zhi Lu

802.11g 30 MHz~3 GHz

Conducted Spurious Emission Plot on Channel 01

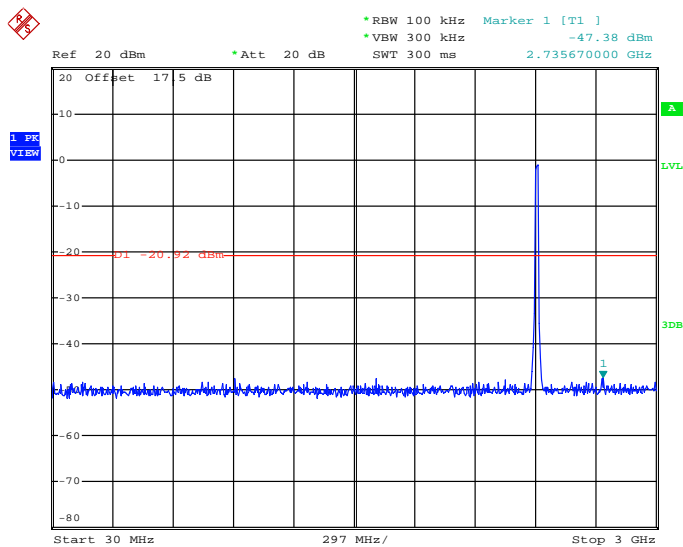

Date: 22.FEB.2013 14:32:48

802.11g 2 GHz~25 GHz

Conducted Spurious Emission Plot on Channel 01

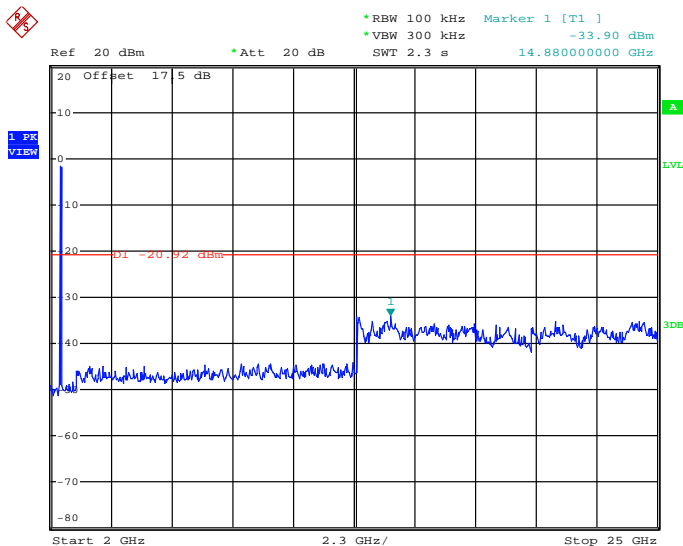

Date: 22.FEB.2013 14:33:06



802.11g 30 MHz~3 GHz

Conducted Spurious Emission Plot on Channel 06

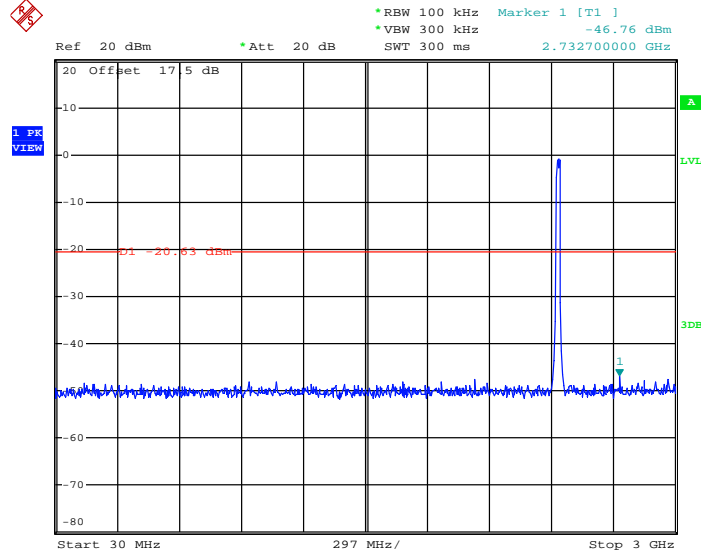

Date: 22.FEB.2013 14:35:58

802.11g 2 GHz~25 GHz

Conducted Spurious Emission Plot on Channel 06

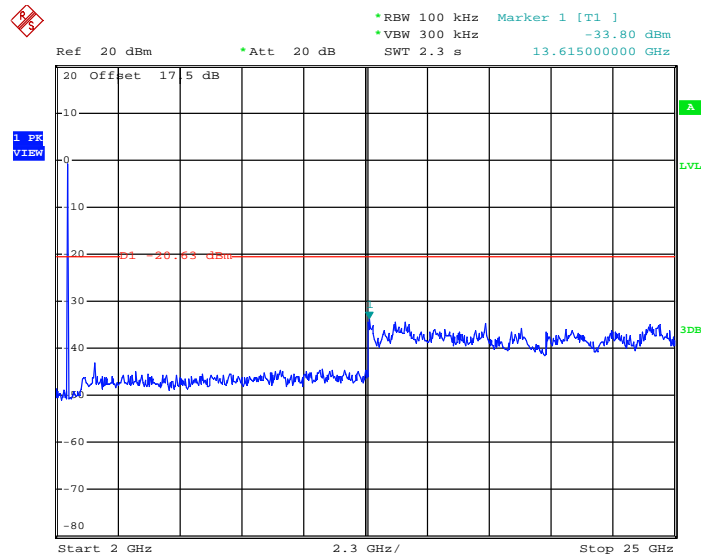

Date: 22.FEB.2013 14:36:17

802.11g 30 MHz~3 GHz

Conducted Spurious Emission Plot on Channel 11

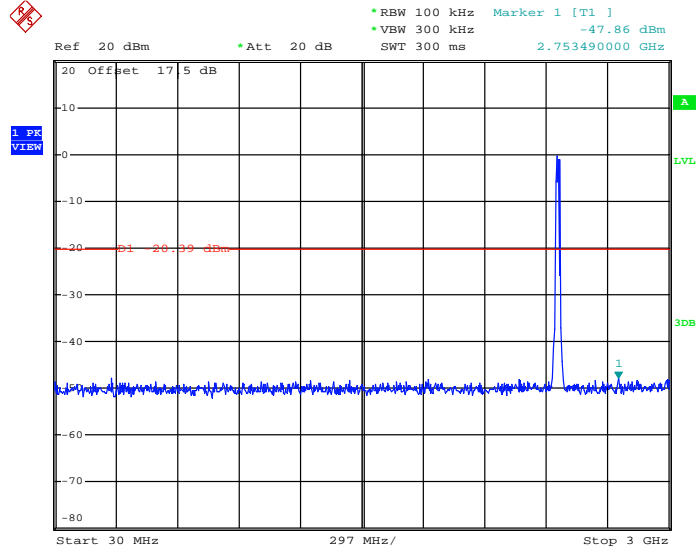

Date: 22.FEB.2013 14:38:53

802.11g 2 GHz~25 GHz

Conducted Spurious Emission Plot on Channel 11

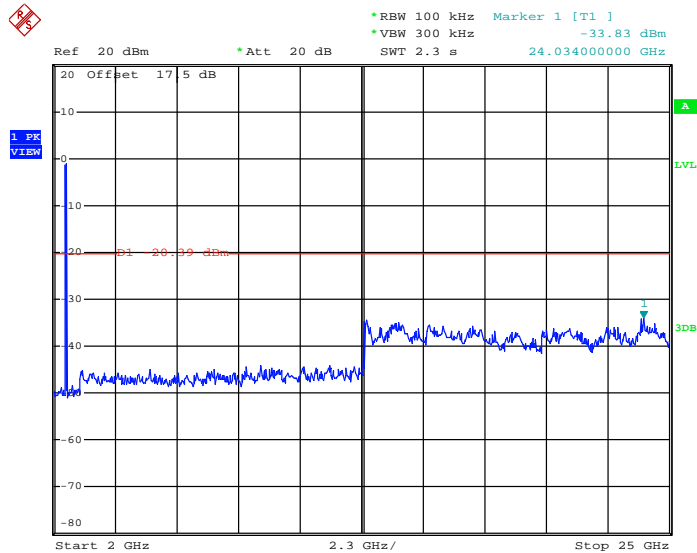

Date: 22.FEB.2013 14:39:12



Test Mode :	802.11n HT20	Temperature :	20~21°C
Test Band :	30MHz-3GHz and 2G-25GHz	Relative Humidity :	40~41%
Test Channel :	01, 06, 11	Test Engineer :	Zhi Lu

802.11n HT20 30 MHz~3 GHz

Conducted Spurious Emission Plot on Channel 01

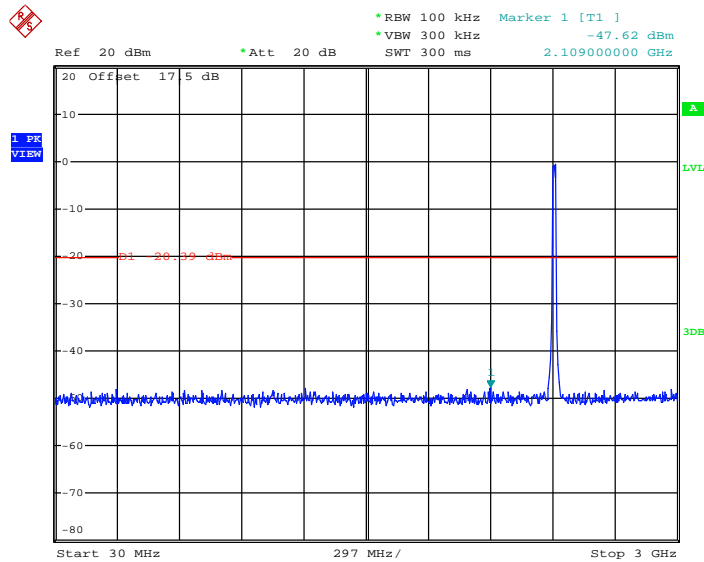

Date: 22.FEB.2013 14:42:42

802.11n HT20 2 GHz~25 GHz

Conducted Spurious Emission Plot on Channel 01

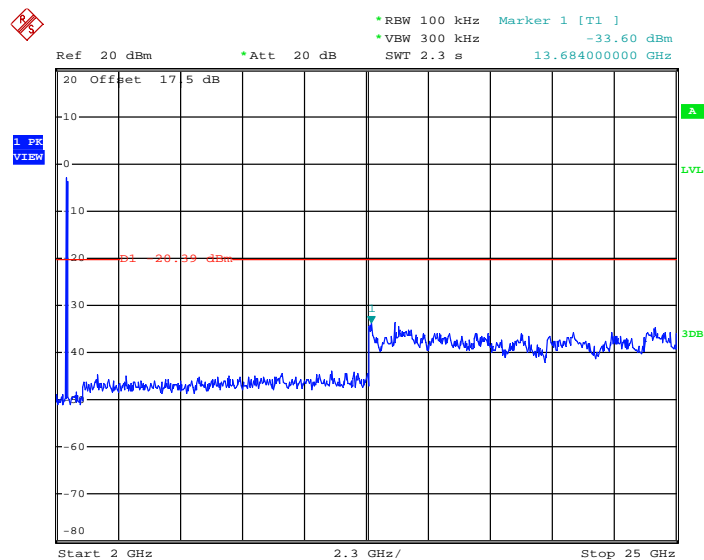

Date: 22.FEB.2013 14:43:00



802.11n HT20 30 MHz~3 GHz

Conducted Spurious Emission Plot on Channel 06

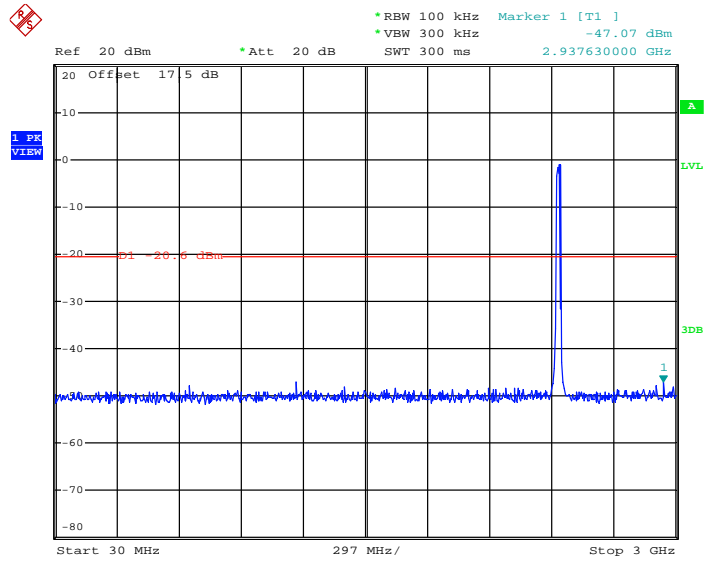

Date: 22.FEB.2013 14:45:08

802.11n HT20 2 GHz~25 GHz

Conducted Spurious Emission Plot on Channel 06

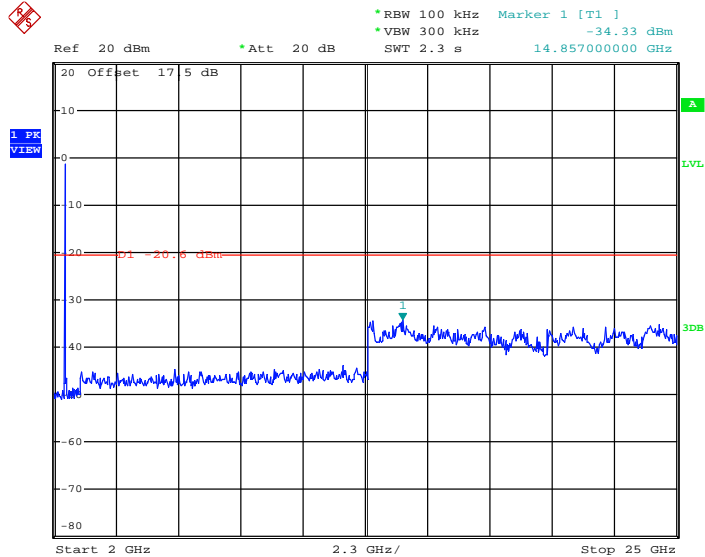

Date: 22.FEB.2013 14:45:27



802.11n HT20 30 MHz~3 GHz

Conducted Spurious Emission Plot on Channel 11

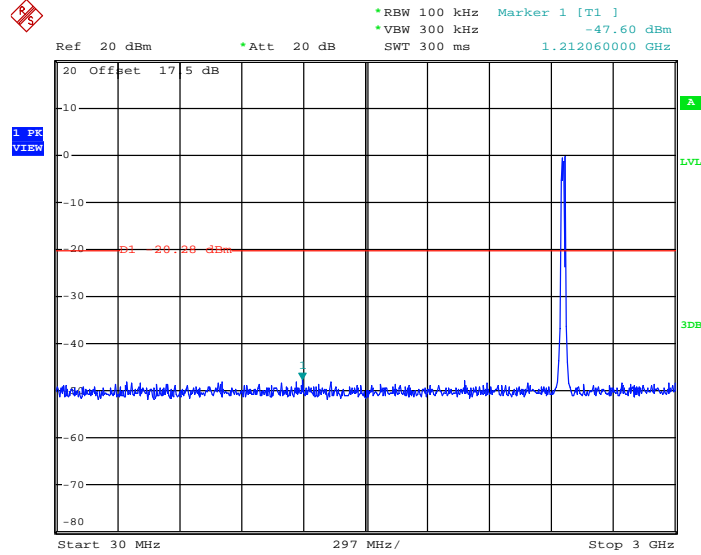

Date: 22.FEB.2013 14:47:54

802.11n HT20 2 GHz~25 GHz

Conducted Spurious Emission Plot on Channel 11

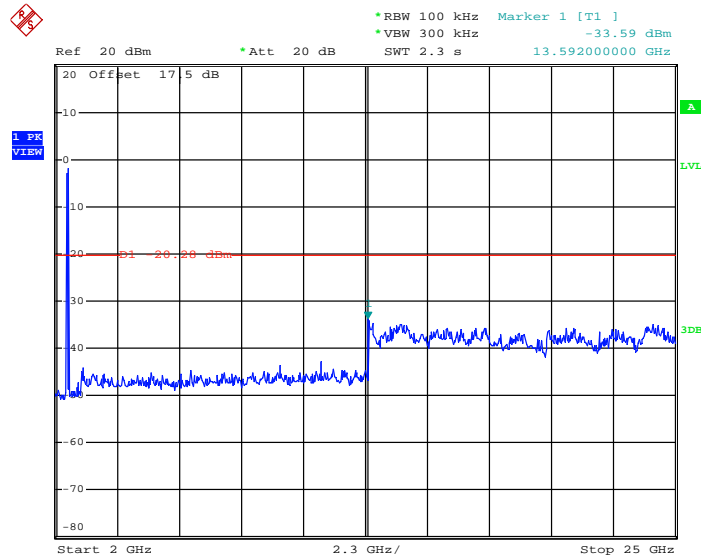

Date: 22.FEB.2013 14:48:13



3.5 Radiated Emission Measurement

3.5.1 Limit of Radiated Emission

In any 100 KHz bandwidth outside the intentional radiator frequency band, all harmonics/spurious must be at least 20 dB below the highest emission level within the authorized band. If the output power of this device was measured by spectrum analyzer, the attenuation under this paragraph shall be 30 dB instead of 20 dB. In addition, radiated emissions which fall in the restricted bands must also comply with the FCC section 15.209 limits as below.

Frequency (MHz)	Field Strength (microvolts/meter)	Measurement Distance (meters)
0.009 – 0.490	2400/F(KHz)	300
0.490 – 1.705	24000/F(KHz)	30
1.705 – 30.0	30	30
30 – 88	100	3
88 – 216	150	3
216 - 960	200	3
Above 960	500	3

3.5.2 Measuring Instruments

See list of measuring instruments of this test report.

3.5.3 Test Procedures

1. The testing follows the guidelines in ANSI C63. 10-2009
2. The EUT was arranged to its worst case and then tune the antenna tower (from 1 m to 4 m) and turntable (from 0 degree to 360 degrees) to find the maximum reading. A pre-amp and a high pass filter are used for the test in order to get better signal level.
3. The EUT was placed on a turntable with 0.8 meter above ground.
4. The EUT was set 3 meters from the interference receiving antenna, which was mounted on the top of a variable height antenna tower.
5. Corrected Reading: Antenna Factor + Cable Loss + Read Level - Preamp Factor = Level
6. For measurement below 1GHz, If the emission level of the EUT measured by the peak detector is 3 dB lower than the applicable limit, the peak emission level will be reported. Otherwise, the emission measurement will be repeated using the quasi-peak detector and reported.
7. Use the following spectrum analyzer settings:
 - (1) Span shall wide enough to fully capture the emission being measured;
 - (2) Set RBW=100 KHz for $f < 1$ GHz; $VBW \geq RBW$; Sweep = auto; Detector function = peak; Trace = max hold;
 - (3) Set RBW = 1 MHz, $VBW = 3$ MHz for $f \geq 1$ GHz for peak measurement.
 For average measurement:
 - $VBW = 10$ Hz, when duty cycle is no less than 98 percent.
 - $VBW \geq 1/T$, when duty cycle is less than 98 percent where T is the minimum transmission duration over which the transmitter is on and is transmitting at its maximum power control level for the tested mode of operation.

Band	Duty Cycle(%)	T(ms)	1/T(KHz)	VBW Setting
802.11b	98.529	-	-	10Hz
802.11g	88.571	0.248	4.032	10KHz
2.4G 802.11n HT20	88.889	0.272	3.676	10KHz

Note: For average measurement with duty cycle < 98%, use reduced VBW measurement method 4.2.3.2.3 in ANSI C63.10.

3.5.4 Test Setup

For radiated emissions below 30MHz

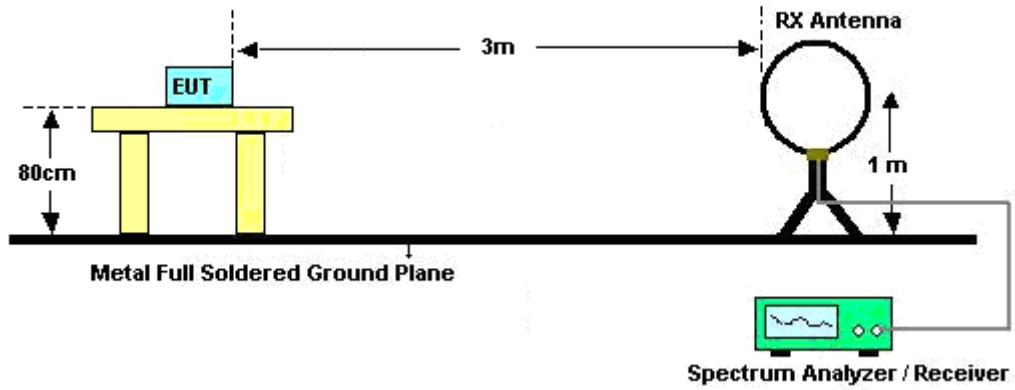

For radiated emissions from 30MHz to 1GHz

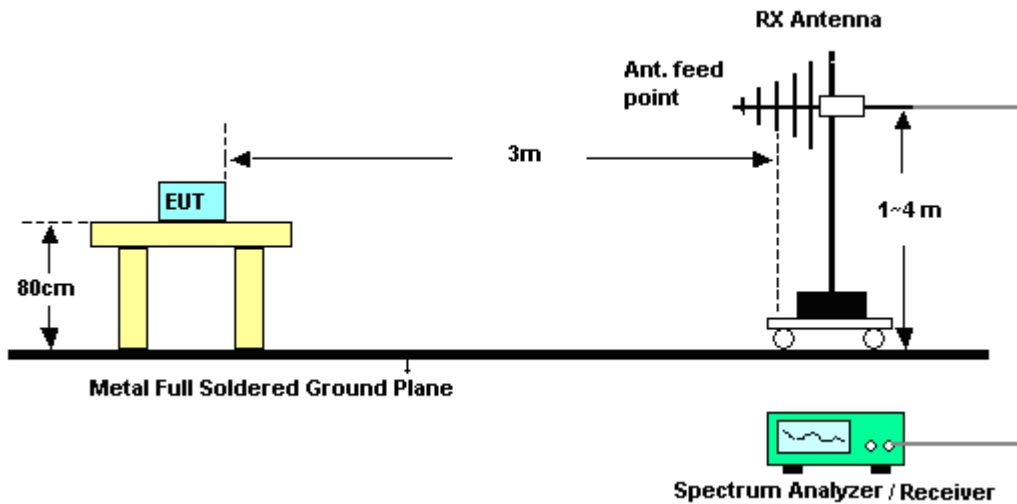

For radiated emissions above 1GHz

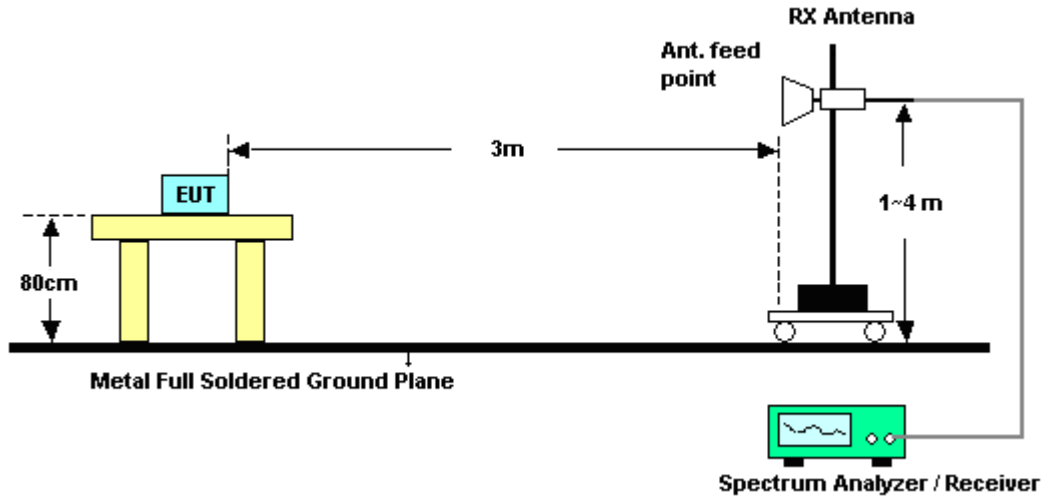

3.5.5 Test Results of Radiated Emissions (9 KHz ~ 30 MHz)

The low frequency, which started from 9 KHz to 30MHz, was pre-scanned and the result which was 20dB lower than the limit line per 15.31(o) was not reported.



3.5.6 Test Result of Radiated Band Edges

Test Mode :	802.11b	Temperature :	21~22°C
Test Band :	Low	Relative Humidity :	42~43%
Test Channel :	01	Test Engineer :	Steven Hao

ANTENNA POLARITY : HORIZONTAL										
Frequency (MHz)	Level (dBμV/m)	Over Limit (dB)	Limit Line (dBμV/m)	Read Level (dBμV)	Antenna Factor (dB)	Cable Loss (dB)	Preamp Factor (dB)	Ant Pos (cm)	Table Pos (deg)	Remark
2390	52.92	-21.08	74	49.48	32.85	2.1	31.51	105	320	Peak
2390	42.24	-11.76	54	38.8	32.85	2.1	31.51	102	45	Average

ANTENNA POLARITY : VERTICAL										
Frequency (MHz)	Level (dBμV/m)	Over Limit (dB)	Limit Line (dBμV/m)	Read Level (dBμV)	Antenna Factor (dB)	Cable Loss (dB)	Preamp Factor (dB)	Ant Pos (cm)	Table Pos (deg)	Remark
2338.89	51.69	-22.31	74	48.37	32.77	2.06	31.51	180	80	Peak
2389.9	37.38	-16.62	54	33.94	32.85	2.1	31.51	175	90	Average

Test Mode :	802.11b	Temperature :	21~22°C
Test Band :	High	Relative Humidity :	42~43%
Test Channel :	11	Test Engineer :	Steven Hao

ANTENNA POLARITY : HORIZONTAL										
Frequency (MHz)	Level (dBμV/m)	Over Limit (dB)	Limit Line (dBμV/m)	Read Level (dBμV)	Antenna Factor (dB)	Cable Loss (dB)	Preamp Factor (dB)	Ant Pos (cm)	Table Pos (deg)	Remark
2483.68	55.03	-18.97	74	51.38	33.01	2.15	31.51	125	79	Peak
2483.5	44.16	-9.84	54	40.51	33.01	2.15	31.51	128	54	Average

ANTENNA POLARITY : VERTICAL										
Frequency (MHz)	Level (dBμV/m)	Over Limit (dB)	Limit Line (dBμV/m)	Read Level (dBμV)	Antenna Factor (dB)	Cable Loss (dB)	Preamp Factor (dB)	Ant Pos (cm)	Table Pos (deg)	Remark
2484.79	53.1	-20.9	74	49.45	33.01	2.15	31.51	107	95	Peak
2483.5	41.72	-12.28	54	38.07	33.01	2.15	31.51	125	80	Average



Test Mode :	802.11g	Temperature :	21~22°C
Test Band :	Low	Relative Humidity :	42~43%
Test Channel :	01	Test Engineer :	Steven Hao

ANTENNA POLARITY : HORIZONTAL										
Frequency (MHz)	Level (dBμV/m)	Over Limit (dB)	Limit Line (dBμV/m)	Read Level (dBμV)	Antenna Factor (dB)	Cable Loss (dB)	Preamp Factor (dB)	Ant Pos (cm)	Table Pos (deg)	Remark
2390	64.95	-9.05	74	61.51	32.85	2.1	31.51	102	350	Peak
2390	48.97	-5.03	54	45.53	32.85	2.1	31.51	102	350	Average

ANTENNA POLARITY : VERTICAL										
Frequency (MHz)	Level (dBμV/m)	Over Limit (dB)	Limit Line (dBμV/m)	Read Level (dBμV)	Antenna Factor (dB)	Cable Loss (dB)	Preamp Factor (dB)	Ant Pos (cm)	Table Pos (deg)	Remark
2388.75	60.46	-13.54	74	57.02	32.85	2.1	31.51	112	15	Peak
2390	45.66	-8.34	54	42.22	32.85	2.1	31.51	112	15	Average

Test Mode :	802.11g	Temperature :	21~22°C
Test Band :	High	Relative Humidity :	42~43%
Test Channel :	11	Test Engineer :	Steven Hao

ANTENNA POLARITY : HORIZONTAL										
Frequency (MHz)	Level (dBμV/m)	Over Limit (dB)	Limit Line (dBμV/m)	Read Level (dBμV)	Antenna Factor (dB)	Cable Loss (dB)	Preamp Factor (dB)	Ant Pos (cm)	Table Pos (deg)	Remark
2483.59	64.1	-9.9	74	60.45	33.01	2.15	31.51	115	24	Peak
2483.74	47.51	-6.49	54	43.86	33.01	2.15	31.51	115	24	Average

ANTENNA POLARITY : VERTICAL										
Frequency (MHz)	Level (dBμV/m)	Over Limit (dB)	Limit Line (dBμV/m)	Read Level (dBμV)	Antenna Factor (dB)	Cable Loss (dB)	Preamp Factor (dB)	Ant Pos (cm)	Table Pos (deg)	Remark
2483.74	59.27	-14.73	74	55.62	33.01	2.15	31.51	140	60	Peak
2483.56	43.56	-10.44	54	39.91	33.01	2.15	31.51	140	60	Average



Test Mode :	802.11n HT20	Temperature :	21~22°C
Test Band :	Low	Relative Humidity :	42~43%
Test Channel :	01	Test Engineer :	Steven Hao

ANTENNA POLARITY : HORIZONTAL										
Frequency (MHz)	Level (dBμV/m)	Over Limit (dB)	Limit Line (dBμV/m)	Read Level (dBμV)	Antenna Factor (dB)	Cable Loss (dB)	Preamp Factor (dB)	Ant Pos (cm)	Table Pos (deg)	Remark
2390	65.44	-8.56	74	62	32.85	2.1	31.51	120	340	Peak
2389.92	50.99	-3.01	54	47.55	32.85	2.1	31.51	120	340	Average

ANTENNA POLARITY : VERTICAL										
Frequency (MHz)	Level (dBμV/m)	Over Limit (dB)	Limit Line (dBμV/m)	Read Level (dBμV)	Antenna Factor (dB)	Cable Loss (dB)	Preamp Factor (dB)	Ant Pos (cm)	Table Pos (deg)	Remark
2390	59.17	-14.83	74	55.73	32.85	2.1	31.51	140	320	Peak
2390	44.98	-9.02	54	41.54	32.85	2.1	31.51	140	320	Average

Test Mode :	802.11n HT20	Temperature :	21~22°C
Test Band :	High	Relative Humidity :	42~43%
Test Channel :	11	Test Engineer :	Steven Hao

ANTENNA POLARITY : HORIZONTAL										
Frequency (MHz)	Level (dBμV/m)	Over Limit (dB)	Limit Line (dBμV/m)	Read Level (dBμV)	Antenna Factor (dB)	Cable Loss (dB)	Preamp Factor (dB)	Ant Pos (cm)	Table Pos (deg)	Remark
2483.68	67.12	-6.88	74	63.47	33.01	2.15	31.51	120	0	Peak
2483.5	48.83	-5.17	54	45.18	33.01	2.15	31.51	120	0	Average

ANTENNA POLARITY : VERTICAL										
Frequency (MHz)	Level (dBμV/m)	Over Limit (dB)	Limit Line (dBμV/m)	Read Level (dBμV)	Antenna Factor (dB)	Cable Loss (dB)	Preamp Factor (dB)	Ant Pos (cm)	Table Pos (deg)	Remark
2483.5	63.13	-10.87	74	59.48	33.01	2.15	31.51	120	130	Peak
2483.5	45.72	-8.28	54	42.07	33.01	2.15	31.51	120	130	Average

3.5.7 Test Result of Radiated Emission (30 MHz ~ 10th Harmonic)

NOTE: Below 1GHz for radiated emission measurement, pre-scanned all test modes and only choose the worst case mode was recorded in the report.

Test Mode :	802.11b	Temperature :	21~22°C
Test Channel :	01	Relative Humidity :	42~43%
Test Engineer :	Steven Hao	Polarization :	Horizontal
Remark :	1. 2412 MHz is fundamental signal which can be ignored. 2. 2399 MHz and 7236 MHz are not within restricted bands, and their limit lines are 20dB below the highest emission level. For example, 108.5 dBuV/m - 20dB = 88.5 dBuV/m. 3. Average measurement was not performed if peak level went lower than the average limit.		

Frequency (MHz)	Level (dBμV/m)	Over Limit (dB)	Limit Line (dBμV/m)	Read Level (dBμV)	Antenna Factor (dB)	Cable Loss (dB)	Preamp Factor (dB)	Ant Pos (cm)	Table Pos (deg)	Remark
2399	60.37	-28.13	88.5	60.37	32.85	2.1	31.51	100	334	Peak
2412	100.99	-	-	97.51	32.88	2.11	31.51	100	334	Average
2412	108.5	-	-	105.02	32.88	2.11	31.51	100	334	Peak
4824	47.61	-26.39	74	40.91	35.16	3.08	31.54	124	55	Peak
7236	47.27	-41.23	88.5	38.84	36.16	3.22	30.95	112	78	Peak



Test Mode :	802.11b	Temperature :	21~22°C
Test Channel :	01	Relative Humidity :	42~43%
Test Engineer :	Steven Hao	Polarization :	Vertical
Remark :	1. 2412 MHz is fundamental signal which can be ignored. 2. 2399 MHz and 7236 MHz are not within restricted bands, and their limit lines are 20dB below the highest emission level. 3. Average measurement was not performed if peak level went lower than the average limit.		

Frequency (MHz)	Level (dBμV/m)	Over Limit (dB)	Limit Line (dBμV/m)	Read Level (dBμV)	Antenna Factor (dB)	Cable Loss (dB)	Preamp Factor (dB)	Ant Pos (cm)	Table Pos (deg)	Remark
2399	53.79	-24.87	78.66	53.79	32.85	2.1	31.51	182	82	Peak
2412	91.25	-	-	87.77	32.88	2.11	31.51	182	82	Average
2412	98.66	-	-	95.18	32.88	2.11	31.51	182	82	Peak
4824	46.24	-27.76	74	39.54	35.16	3.08	31.54	124	89	Peak
7236	47.75	-30.91	78.66	39.32	36.16	3.22	30.95	127	69	Peak



Test Mode :	802.11b	Temperature :	21~22°C
Test Channel :	06	Relative Humidity :	42~43%
Test Engineer :	Steven Hao	Polarization :	Horizontal
Remark :	1. 2437 MHz is fundamental signal which can be ignored. 2. Average measurement was not performed if peak level went lower than the average limit.		

Frequency (MHz)	Level (dBμV/m)	Over Limit (dB)	Limit Line (dBμV/m)	Read Level (dBμV)	Antenna Factor (dB)	Cable Loss (dB)	Preamp Factor (dB)	Ant Pos (cm)	Table Pos (deg)	Remark
2437	101.36	-	-	97.8	32.94	2.13	31.51	100	338	Average
2437	108.87	-	-	105.31	32.94	2.13	31.51	100	338	Peak
4874	47.26	-26.74	74	40.49	35.18	3.11	31.52	127	56	Peak
7311	46.89	-27.11	74	38.44	36.19	3.2	30.94	145	289	Peak

Test Mode :	802.11b	Temperature :	21~22°C
Test Channel :	06	Relative Humidity :	42~43%
Test Engineer :	Steven Hao	Polarization :	Vertical
Remark :	1. 2437 MHz is fundamental signal which can be ignored. 2. Average measurement was not performed if peak level went lower than the average limit.		

Frequency (MHz)	Level (dBμV/m)	Over Limit (dB)	Limit Line (dBμV/m)	Read Level (dBμV)	Antenna Factor (dB)	Cable Loss (dB)	Preamp Factor (dB)	Ant Pos (cm)	Table Pos (deg)	Remark
2437	96.72	-	-	93.16	32.94	2.13	31.51	100	82	Average
2437	104.12	-	-	100.56	32.94	2.13	31.51	100	82	Peak
4874	47.89	-26.11	74	41.12	35.18	3.11	31.52	120	320	Peak
7311	48.53	-25.47	74	40.08	36.19	3.2	30.94	108	96	Peak



Test Mode :	802.11b	Temperature :	21~22°C
Test Channel :	11	Relative Humidity :	42~43%
Test Engineer :	Steven Hao	Polarization :	Horizontal
Remark :	1. 2462 MHz is fundamental signal which can be ignored. 2. Average measurement was not performed if peak level went lower than the average limit.		

Frequency (MHz)	Level (dBμV/m)	Over Limit (dB)	Limit Line (dBμV/m)	Read Level (dBμV)	Antenna Factor (dB)	Cable Loss (dB)	Preamp Factor (dB)	Ant Pos (cm)	Table Pos (deg)	Remark
2462	100.33	-	-	96.72	32.98	2.14	31.51	122	34	Average
2462	109.52	-	-	105.91	32.98	2.14	31.51	122	34	Peak
4924	46.06	-27.94	74	39.25	35.18	3.14	31.51	125	76	Peak
7386	48.43	-25.57	74	39.95	36.23	3.18	30.93	184	39	Peak

Test Mode :	802.11b	Temperature :	21~22°C
Test Channel :	11	Relative Humidity :	42~43%
Test Engineer :	Steven Hao	Polarization :	Vertical
Remark :	1. 2462 MHz is fundamental signal which can be ignored. 2. Average measurement was not performed if peak level went lower than the average limit.		

Frequency (MHz)	Level (dBμV/m)	Over Limit (dB)	Limit Line (dBμV/m)	Read Level (dBμV)	Antenna Factor (dB)	Cable Loss (dB)	Preamp Factor (dB)	Ant Pos (cm)	Table Pos (deg)	Remark
2462	97.37	-	-	93.76	32.98	2.14	31.51	100	73	Average
2462	105.34	-	-	101.73	32.98	2.14	31.51	100	73	Peak
4924	46.56	-27.44	74	39.75	35.18	3.14	31.51	120	290	Peak
7386	47.97	-26.03	74	39.49	36.23	3.18	30.93	156	247	Peak



Test Mode :	802.11g	Temperature :	21~22°C
Test Channel :	01	Relative Humidity :	42~43%
Test Engineer :	Steven Hao	Polarization :	Horizontal
Remark :	<ol style="list-style-type: none"> 2412 MHz is fundamental signal which can be ignored. 2399 MHz and 7236 MHz are not within restricted bands, and their limit lines are 20dB below the highest emission level. Average measurement was not performed if peak level went lower than the average limit. 		

Frequency (MHz)	Level (dBμV/m)	Over Limit (dB)	Limit Line (dBμV/m)	Read Level (dBμV)	Antenna Factor (dB)	Cable Loss (dB)	Preamp Factor (dB)	Ant Pos (cm)	Table Pos (deg)	Remark
2399	79.86	-7.27	87.13	76.42	32.85	2.1	31.51	100	348	Peak
2412	96.03	-	-	92.55	32.88	2.11	31.51	100	348	Average
2412	107.13	-	-	103.65	32.88	2.11	31.51	100	348	Peak
4824	49.04	-24.96	74	42.34	35.16	3.08	31.54	105	89	Peak
7236	44.08	-43.05	87.13	35.65	36.16	3.22	30.95	108	320	Peak



Test Mode :	802.11g	Temperature :	21~22°C
Test Channel :	01	Relative Humidity :	42~43%
Test Engineer :	Steven Hao	Polarization :	Vertical
Remark :	1. 2412 MHz is fundamental signal which can be ignored. 2. 2399 MHz and 7236 MHz are not within restricted bands, and their limit lines are 20dB below the highest emission level. 3. Average measurement was not performed if peak level went lower than the average limit.		

Frequency (MHz)	Level (dBμV/m)	Over Limit (dB)	Limit Line (dBμV/m)	Read Level (dBμV)	Antenna Factor (dB)	Cable Loss (dB)	Preamp Factor (dB)	Ant Pos (cm)	Table Pos (deg)	Remark
2399	74.06	-8.54	82.6	70.62	32.85	2.1	31.51	110	6	Peak
2412	91.92	-	-	88.44	32.88	2.11	31.51	110	6	Average
2412	102.6	-	-	99.12	32.88	2.11	31.51	110	6	Peak
4824	48.28	-25.72	74	41.58	35.16	3.08	31.54	104	350	Peak
7236	43.54	-39.06	82.6	35.11	36.16	3.22	30.95	110	120	Peak



Test Mode :	802.11g	Temperature :	21~22°C
Test Channel :	06	Relative Humidity :	42~43%
Test Engineer :	Steven Hao	Polarization :	Horizontal
Remark :	1. 2437 MHz is fundamental signal which can be ignored. 2. Average measurement was not performed if peak level went lower than the average limit.		

Frequency (MHz)	Level (dBμV/m)	Over Limit (dB)	Limit Line (dBμV/m)	Read Level (dBμV)	Antenna Factor (dB)	Cable Loss (dB)	Preamp Factor (dB)	Ant Pos (cm)	Table Pos (deg)	Remark
2437	96.04	-	-	92.48	32.94	2.13	31.51	100	348	Average
2437	106.72	-	-	103.16	32.94	2.13	31.51	100	348	Peak
4874	47.86	-26.14	74	41.09	35.18	3.11	31.52	110	79	Peak
7311	46.02	-27.98	74	37.57	36.19	3.2	30.94	124	58	Peak

Test Mode :	802.11g	Temperature :	21~22°C
Test Channel :	06	Relative Humidity :	42~43%
Test Engineer :	Steven Hao	Polarization :	Vertical
Remark :	1. 2437 MHz is fundamental signal which can be ignored. 2. Average measurement was not performed if peak level went lower than the average limit.		

Frequency (MHz)	Level (dBμV/m)	Over Limit (dB)	Limit Line (dBμV/m)	Read Level (dBμV)	Antenna Factor (dB)	Cable Loss (dB)	Preamp Factor (dB)	Ant Pos (cm)	Table Pos (deg)	Remark
2437	92.01	-	-	88.45	32.94	2.13	31.51	145	312	Average
2437	102.76	-	-	99.2	32.94	2.13	31.51	145	312	Peak
4874	47.19	-26.81	74	40.42	35.18	3.11	31.52	105	90	Peak
7311	47.49	-26.51	74	39.04	36.19	3.2	30.94	120	340	Peak



Test Mode :	802.11g	Temperature :	21~22°C
Test Channel :	11	Relative Humidity :	42~43%
Test Engineer :	Steven Hao	Polarization :	Horizontal
Remark :	1. 2462 MHz is fundamental signal which can be ignored. 2. Average measurement was not performed if peak level went lower than the average limit.		

Frequency (MHz)	Level (dBμV/m)	Over Limit (dB)	Limit Line (dBμV/m)	Read Level (dBμV)	Antenna Factor (dB)	Cable Loss (dB)	Preamp Factor (dB)	Ant Pos (cm)	Table Pos (deg)	Remark
2462	95.18	-	-	91.57	32.98	2.14	31.51	152	46	Average
2462	106.76	-	-	103.15	32.98	2.14	31.51	152	46	Peak
4924	48.78	-25.22	74	41.97	35.18	3.14	31.51	115	80	Peak
7386	43.53	-30.47	74	35.05	36.23	3.18	30.93	104	40	Peak

Test Mode :	802.11g	Temperature :	21~22°C
Test Channel :	11	Relative Humidity :	42~43%
Test Engineer :	Steven Hao	Polarization :	Vertical
Remark :	1. 2462 MHz is fundamental signal which can be ignored. 2. Average measurement was not performed if peak level went lower than the average limit.		

Frequency (MHz)	Level (dBμV/m)	Over Limit (dB)	Limit Line (dBμV/m)	Read Level (dBμV)	Antenna Factor (dB)	Cable Loss (dB)	Preamp Factor (dB)	Ant Pos (cm)	Table Pos (deg)	Remark
2462	89.57	-	-	85.96	32.98	2.14	31.51	143	72	Average
2462	100.41	-	-	96.8	32.98	2.14	31.51	143	72	Peak
4924	48.66	-25.34	74	41.85	35.18	3.14	31.51	140	289	Peak
7386	45.56	-28.44	74	37.08	36.23	3.18	30.93	128	115	Peak



Test Mode :	802.11n HT20	Temperature :	21~22°C
Test Channel :	01	Relative Humidity :	42~43%
Test Engineer :	Steven Hao	Polarization :	Horizontal
Remark :	1. 2412 MHz is fundamental signal which can be ignored. 2. 2399 MHz and 7236 MHz are not within restricted bands, and their limit lines are 20dB below the highest emission level. 3. Average measurement was not performed if peak level went lower than the average limit.		

Frequency (MHz)	Level (dBμV/m)	Over Limit (dB)	Limit Line (dBμV/m)	Read Level (dBμV)	Antenna Factor (dB)	Cable Loss (dB)	Preamp Factor (dB)	Ant Pos (cm)	Table Pos (deg)	Remark
57.59	22.91	-17.09	40	50.28	5.74	0.46	33.57	-	-	Peak
96.1	27.71	-15.79	43.5	50.86	9.9	0.56	33.61	-	-	Peak
104.17	29.59	-13.91	43.5	51.61	11.01	0.58	33.61	115	320	Peak
172.6	22.35	-21.15	43.5	46.18	8.97	0.76	33.56	-	-	Peak
197.89	20.26	-23.24	43.5	44.11	8.89	0.81	33.55	-	-	Peak
319.94	26.72	-19.28	46	45.52	13.54	1.02	33.36	-	-	Peak
2399	80.2	-5.88	86.08	76.76	32.85	2.1	31.51	126	341	Peak
2412	95.82	-	-	92.34	32.88	2.11	31.51	126	341	Average
2412	106.08	-	-	102.6	32.88	2.11	31.51	126	341	Peak
4824	47.99	-26.01	74	41.29	35.16	3.08	31.54	140	360	Peak
7236	42.92	-43.16	86.08	34.49	36.16	3.22	30.95	115	78	Peak



Test Mode :	802.11n HT20	Temperature :	21~22°C
Test Channel :	01	Relative Humidity :	42~43%
Test Engineer :	Steven Hao	Polarization :	Vertical
Remark :	1. 2412 MHz is fundamental signal which can be ignored. 2. 2399 MHz and 7236 MHz are not within restricted bands, and their limit lines are 20dB below the highest emission level. 3. Average measurement was not performed if peak level went lower than the average limit.		

Frequency (MHz)	Level (dBμV/m)	Over Limit (dB)	Limit Line (dBμV/m)	Read Level (dBμV)	Antenna Factor (dB)	Cable Loss (dB)	Preamp Factor (dB)	Ant Pos (cm)	Table Pos (deg)	Remark
57.59	31.49	-8.51	40	58.86	5.74	0.46	33.57	105	89	Peak
96.1	26.22	-17.28	43.5	49.37	9.9	0.56	33.61	-	-	Peak
104.17	27.98	-15.52	43.5	50	11.01	0.58	33.61	-	-	Peak
107.89	26.81	-16.69	43.5	48.29	11.53	0.59	33.6	-	-	Peak
360.45	23.22	-22.78	46	40.72	14.74	1.1	33.34	-	-	Peak
945.44	27.76	-18.24	46	37.75	20.7	1.74	32.43	-	-	Peak
2399	73.3	-6.37	79.67	69.86	32.85	2.1	31.51	147	322	Peak
2412	88.97	-	-	85.49	32.88	2.11	31.51	147	322	Average
2412	99.67	-	-	96.19	32.88	2.11	31.51	147	322	Peak
4824	49.48	-24.52	74	42.78	35.16	3.08	31.54	120	342	Peak
7236	43.41	-36.26	79.67	34.98	36.16	3.22	30.95	124	75	Peak



Test Mode :	802.11n HT20	Temperature :	21~22°C
Test Channel :	06	Relative Humidity :	42~43%
Test Engineer :	Steven Hao	Polarization :	Horizontal
Remark :	1. 2437 MHz is fundamental signal which can be ignored. 2. Average measurement was not performed if peak level went lower than the average limit.		

Frequency (MHz)	Level (dBμV/m)	Over Limit (dB)	Limit Line (dBμV/m)	Read Level (dBμV)	Antenna Factor (dB)	Cable Loss (dB)	Preamp Factor (dB)	Ant Pos (cm)	Table Pos (deg)	Remark
2437	97.04	-	-	93.48	32.94	2.13	31.51	153	48	Average
2437	107.63	-	-	104.07	32.94	2.13	31.51	153	48	Peak
4874	48.45	-25.55	74	41.68	35.18	3.11	31.52	136	85	Peak
7311	44.5	-29.5	74	36.05	36.19	3.2	30.94	128	96	Peak

Test Mode :	802.11n HT20	Temperature :	21~22°C
Test Channel :	06	Relative Humidity :	42~43%
Test Engineer :	Steven Hao	Polarization :	Vertical
Remark :	1. 2437 MHz is fundamental signal which can be ignored. 2. Average measurement was not performed if peak level went lower than the average limit.		

Frequency (MHz)	Level (dBμV/m)	Over Limit (dB)	Limit Line (dBμV/m)	Read Level (dBμV)	Antenna Factor (dB)	Cable Loss (dB)	Preamp Factor (dB)	Ant Pos (cm)	Table Pos (deg)	Remark
2437	88.53	-	-	84.97	32.94	2.13	31.51	150	299	Average
2437	99.1	-	-	95.54	32.94	2.13	31.51	150	299	Peak
4874	49.88	-24.12	74	43.11	35.18	3.11	31.52	108	326	Peak
7311	44.43	-29.57	74	35.98	36.19	3.2	30.94	119	86	Peak



Test Mode :	802.11n HT20	Temperature :	21~22°C
Test Channel :	11	Relative Humidity :	42~43%
Test Engineer :	Steven Hao	Polarization :	Horizontal
Remark :	1. 2462 MHz is fundamental signal which can be ignored. 2. Average measurement was not performed if peak level went lower than the average limit.		

Frequency (MHz)	Level (dBμV/m)	Over Limit (dB)	Limit Line (dBμV/m)	Read Level (dBμV)	Antenna Factor (dB)	Cable Loss (dB)	Preamp Factor (dB)	Ant Pos (cm)	Table Pos (deg)	Remark
2462	94.63	-	-	91.02	32.98	2.14	31.51	126	0	Average
2462	105.36	-	-	101.75	32.98	2.14	31.51	126	0	Peak
4924	48.92	-25.08	74	42.11	35.18	3.14	31.51	146	298	Peak
7386	45.11	-28.89	74	36.63	36.23	3.18	30.93	115	92	Peak

Test Mode :	802.11n HT20	Temperature :	21~22°C
Test Channel :	11	Relative Humidity :	42~43%
Test Engineer :	Steven Hao	Polarization :	Vertical
Remark :	1. 2462 MHz is fundamental signal which can be ignored. 2. Average measurement was not performed if peak level went lower than the average limit.		

Frequency (MHz)	Level (dBμV/m)	Over Limit (dB)	Limit Line (dBμV/m)	Read Level (dBμV)	Antenna Factor (dB)	Cable Loss (dB)	Preamp Factor (dB)	Ant Pos (cm)	Table Pos (deg)	Remark
2462	90.87	-	-	87.26	32.98	2.14	31.51	121	134	Average
2462	102.17	-	-	98.56	32.98	2.14	31.51	121	134	Peak
4924	50.53	-23.47	74	43.72	35.18	3.14	31.51	117	30	Peak
7386	43.93	-30.07	74	35.45	36.23	3.18	30.93	128	327	Peak

3.6 AC Conducted Emission Measurement

3.6.1 Limit of AC Conducted Emission

For equipment that is designed to be connected to the public utility (AC) power line, the radio frequency voltage that is conducted back onto the AC power line on any frequency or frequencies within the band 150 KHz to 30 MHz shall not exceed the limits in the following table.

Frequency of Emission (MHz)	Conducted Limit (dBuV)	
	Quasi-Peak	Average
0.15-0.5	66 to 56*	56 to 46*
0.5-5	56	46
5-30	60	50

*Decreases with the logarithm of the frequency.

3.6.2 Measuring Instruments

See list of measuring instruments of this test report.

3.6.3 Test Procedures

1. The testing follows the guidelines in ANSI C63.4-2003 and ANSI C63.10-2009.
2. The EUT was placed 0.4 meter from the conducting wall of the shielding room, and it was kept at least 80 centimeters from any other grounded conducting surface.
3. Connect EUT to the power mains through a line impedance stabilization network (LISN).
4. All the support units are connecting to the other LISN.
5. The LISN provides 50 ohm coupling impedance for the measuring instrument.
6. The FCC states that a 50 ohm, 50 microhenry LISN should be used.
7. Both sides of AC line were checked for maximum conducted interference.
8. The frequency range from 150 KHz to 30 MHz was searched.
9. Set the test-receiver system to Peak Detect Function and specified bandwidth with Maximum Hold Mode.

3.6.4 Test Setup

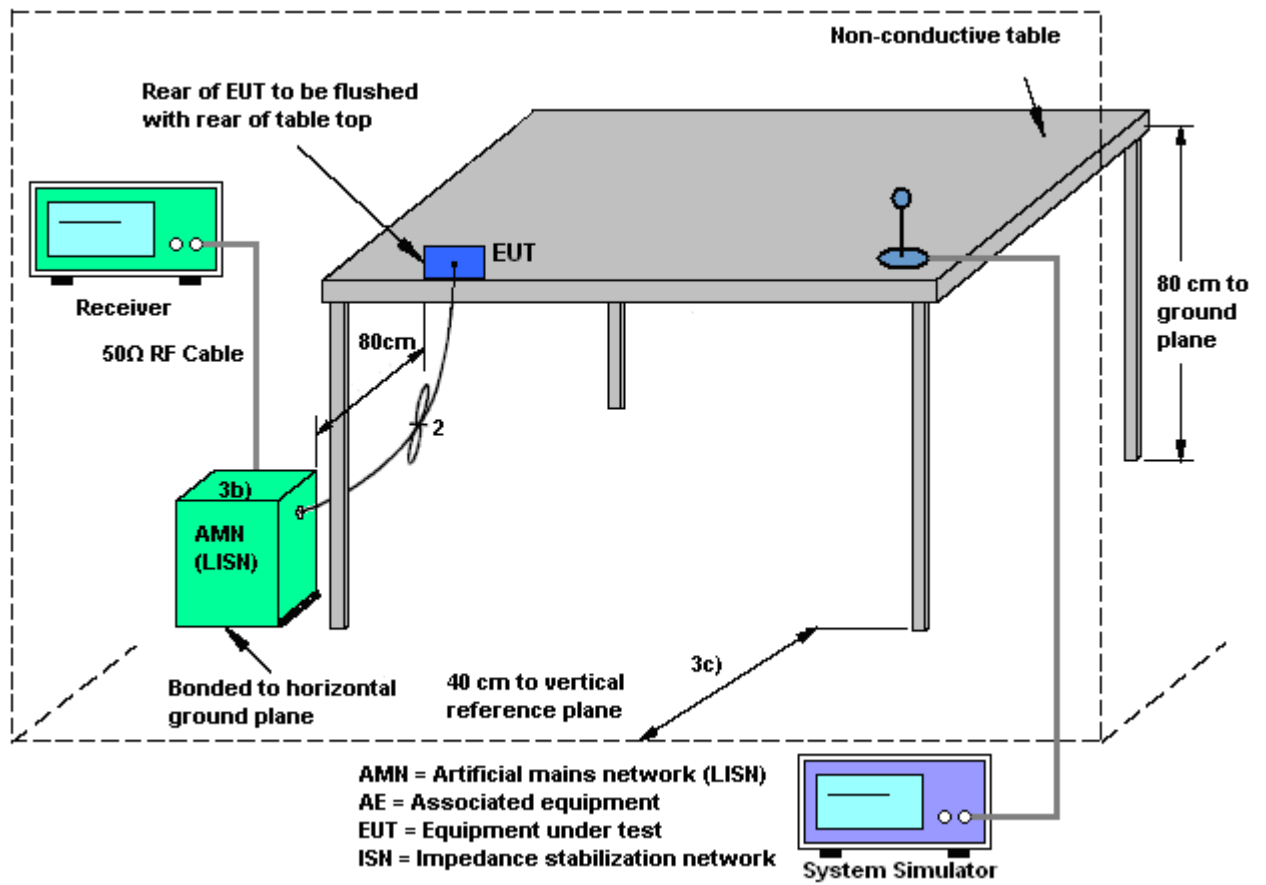



3.6.5 Test Result of AC Conducted Emission

Test Mode :	Mode 1	Temperature :	19~20°C
Test Engineer :	Tom Wang	Relative Humidity :	39~40%
Test Voltage :	120Vac / 60Hz	Phase :	Line
Function Type :	CDMA2000 BC0 Idle + Bluetooth Link + WLAN Link + USB Cable (Charging from Adapter) + Earphone		
Remark :	All emissions not reported here are more than 10 dB below the prescribed limit.		

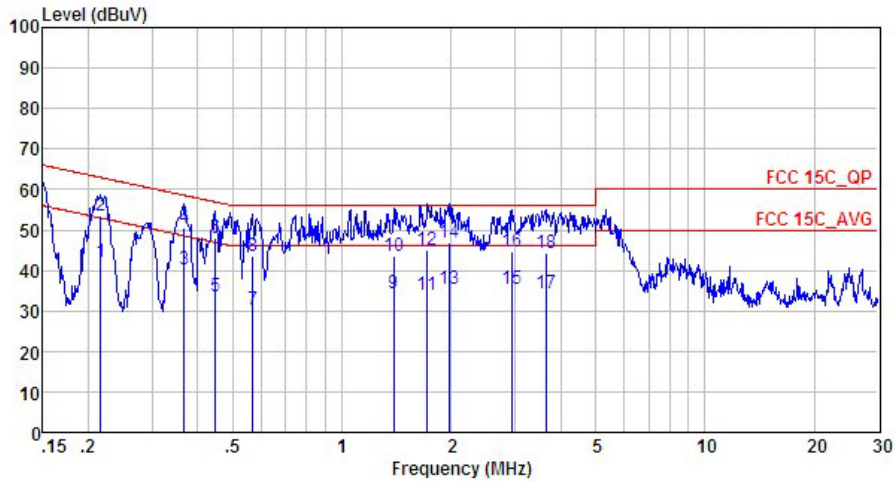

Site : CO01-KS
 Condition: FCC 15C QP LISN_L_2000601 LINE

Mode : Mode 1

	Freq	Level	Over Limit	Limit Line	Read Level	LISN Factor	Cable Loss	Remark
	MHz	dBuV	dB	dBuV	dBuV	dB	dB	
1	0.22	42.18	-10.78	52.96	32.10	0.02	10.06	Average
2	0.22	53.38	-9.58	62.96	43.30	0.02	10.06	QP
3	0.37	40.29	-8.27	48.56	30.20	0.02	10.07	Average
4 *	0.37	50.39	-8.17	58.56	40.30	0.02	10.07	QP
5	0.45	33.50	-13.39	46.89	23.40	0.02	10.08	Average
6	0.45	48.00	-8.89	56.89	37.90	0.02	10.08	QP
7	0.57	30.41	-15.59	46.00	20.30	0.02	10.09	Average
8	0.57	43.71	-12.29	56.00	33.60	0.02	10.09	QP
9	1.39	34.15	-11.85	46.00	24.00	0.03	10.12	Average
10	1.39	43.55	-12.45	56.00	33.40	0.03	10.12	QP
11	1.72	34.07	-11.93	46.00	23.91	0.03	10.13	Average
12	1.72	45.07	-10.93	56.00	34.91	0.03	10.13	QP
13	1.98	35.28	-10.72	46.00	25.09	0.04	10.15	Average
14	1.98	46.98	-9.02	56.00	36.79	0.04	10.15	QP
15	2.93	35.33	-10.67	46.00	25.10	0.04	10.19	Average
16	2.93	44.63	-11.37	56.00	34.40	0.04	10.19	QP
17	3.64	34.34	-11.66	46.00	24.10	0.05	10.19	Average
18	3.64	44.34	-11.66	56.00	34.10	0.05	10.19	QP



Test Mode :	Mode 1	Temperature :	19~20°C
Test Engineer :	Tom Wang	Relative Humidity :	39~40%
Test Voltage :	120Vac / 60Hz	Phase :	Neutral
Function Type :	CDMA2000 BC0 Idle + Bluetooth Link + WLAN Link + USB Cable (Charging from Adapter) + Earphone		
Remark :	All emissions not reported here are more than 10 dB below the prescribed limit.		

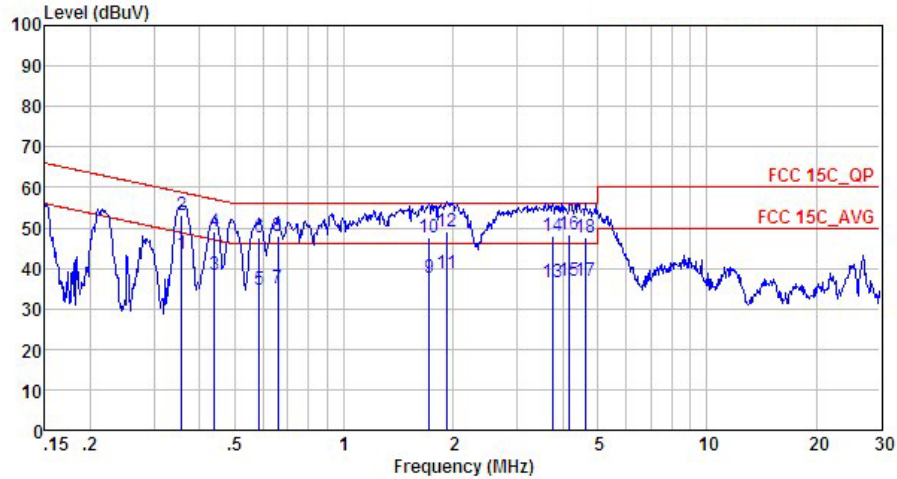

Site : CO01-KS
 Condition: FCC 15C_QP LISN_N_2000601 NEUTRAL

Mode : Mode 1

	Freq	Level	Over Limit	Limit Line	Read Level	LISN Factor	Cable Loss	Remark
	MHz	dBuV	dB	dBuV	dBuV	dB	dB	
1 *	0.36	43.69	-5.09	48.78	33.60	0.02	10.07	Average
2	0.36	53.19	-5.59	58.78	43.10	0.02	10.07	QP
3	0.44	38.30	-8.77	47.07	28.20	0.02	10.08	Average
4	0.44	49.00	-8.07	57.07	38.90	0.02	10.08	QP
5	0.59	34.61	-11.39	46.00	24.50	0.02	10.09	Average
6	0.59	47.71	-8.29	56.00	37.60	0.02	10.09	QP
7	0.66	35.02	-10.98	46.00	24.90	0.02	10.10	Average
8	0.66	48.12	-7.88	56.00	38.00	0.02	10.10	QP
9	1.72	37.66	-8.34	46.00	27.50	0.03	10.13	Average
10	1.72	47.76	-8.24	56.00	37.60	0.03	10.13	QP
11	1.93	38.58	-7.42	46.00	28.40	0.03	10.15	Average
12	1.93	49.08	-6.92	56.00	38.90	0.03	10.15	QP
13	3.76	36.45	-9.55	46.00	26.20	0.06	10.19	Average
14	3.76	48.05	-7.95	56.00	37.80	0.06	10.19	QP
15	4.18	36.96	-9.04	46.00	26.70	0.07	10.19	Average
16	4.18	48.26	-7.74	56.00	38.00	0.07	10.19	QP
17	4.62	36.96	-9.04	46.00	26.70	0.07	10.19	Average
18	4.62	47.76	-8.24	56.00	37.50	0.07	10.19	QP



3.7 Antenna Requirements

3.7.1 Standard Applicable

If directional gain of transmitting antennas is greater than 6dBi, the power shall be reduced by the same level in dB comparing to gain minus 6dBi. For the fixed point-to-point operation, the power shall be reduced by one dB for every 3 dB that the directional gain of the antenna exceeds 6 dBi. The use of a permanently attached antenna or of an antenna that uses a unique coupling to the intentional radiator shall be considered sufficient to comply with the FCC rule.

3.7.2 Antenna Connected Construction

Non-standard connector used.

3.7.3 Antenna Gain

The antenna peak gain of EUT is less than 6 dBi. Therefore, it is not necessary to reduce maximum peak output power limit.



4 List of Measuring Equipment

Instrument	Manufacturer	Model No.	Serial No.	Characteristics	Calibration Date	Test Date	Due Date	Remark
Spectrum Analyzer	R&S	FSP40	100319	9kHz~40GHz	Dec. 29, 2012	Feb. 22, 2013	Dec. 28, 2013	Conducted (TH01-KS)
Power Meter	Agilent	E4416A	MY45101555	N/A	Aug. 22, 2012	Feb. 22, 2013	Aug. 21, 2013	Conducted (TH01-KS)
Power Sensor	Agilent	E9327A	MY44421198	N/A	Aug. 22, 2012	Feb. 22, 2013	Aug. 21, 2013	Conducted (TH01-KS)
DC Power Supply	GWINSTEK	GPS-3030D	E1884515	N/A	Aug. 22, 2012	Feb. 22, 2013	Aug. 21, 2013	Conducted (TH01-KS)
Thermal Chamber	Ten Billion	TTC-B3S	TBN-960502	N/A	Dec. 29, 2012	Feb. 22, 2013	Dec. 28, 2013	Conducted (TH01-KS)
EMI Test Receiver	R&S	ESCI	100534	9kHz~3GHz	Nov. 08, 2012	Feb. 28, 2013	Nov. 07, 2013	Radiation (03CH01-KS)
Spectrum Analyzer	R&S	FSP30	100400	9kHz~30GHz	Jun. 01, 2012	Feb. 28, 2013	May 31, 2013	Radiation (03CH01-KS)
Bilog Antenna	SCHAFFNER	CBL6112D	23182	25MHz~2GHz	Dec. 07, 2012	Feb. 28, 2013	Dec. 06, 2013	Radiation (03CH01-KS)
Loop Antenna	R&S	HFH2-Z2	860004/001	9 kHz~30 MHz	Jul. 03, 2012	Feb. 28, 2013	Jul. 02, 2014	Radiation (03CH01-KS)
Double Ridge Horn Antenna	ETS-Lindgren	1908/7/13	00075957	1GHz~18GHz	Dec. 07, 2012	Feb. 28, 2013	Dec. 06, 2013	Radiation (03CH01-KS)
Amplifier	com-power	PA-103A	161069	1MHz~1GHz	Jun. 01, 2012	Feb. 28, 2013	May 31, 2013	Radiation (03CH01-KS)
Amplifier	Agilent	8449B	3008A02370	1GHz~26.5GHz	Dec. 29, 2012	Feb. 28, 2013	Dec. 28, 2013	Radiation (03CH01-KS)
Active Horn Antenna	com-power	AHA-118	701023	1GHz~18GHz	Nov. 07, 2012	Feb. 28, 2013	Nov. 06, 2013	Radiation (03CH01-KS)
SHF-EHF Horn	Schwarzbeck	BBHA 9170	9170249	15GHz~40GHz	Nov. 23, 2012	Feb. 28, 2013	Nov. 22, 2013	Radiation (03CH01-KS)
EMI Receiver	R&S	ESCI7	100768	9kHz~7GHz	Jun. 01, 2012	Feb. 19, 2013	May 31, 2013	Conduction (CO01-KS)
LISN	MessTec	AN3016	60103	9kHz~30MHz	Dec. 29, 2012	Feb. 19, 2013	Dec. 28, 2013	Conduction (CO01-KS)
LISN	MessTec	AN3016	60105	9kHz~30MHz	Dec. 29, 2012	Feb. 19, 2013	Dec. 28, 2013	Conduction (CO01-KS)
AC Power Source	Chroma	61602	ABP000000811	N/A	Nov. 15, 2012	Feb. 19, 2013	Nov. 14, 2013	Conduction (CO01-KS)
System Simulator	R&S	CMU200	837587/066	2G Full-Band	Dec. 29, 2012	Feb. 19, 2013	Dec. 28, 2013	Conduction (CO01-KS)



5 Uncertainty of Evaluation

Uncertainty of Conducted Emission Measurement (150 KHz ~ 30 MHz)

Measuring Uncertainty for a Level of Confidence of 95% ($U = 2Uc(y)$)	2.26
---	------

Uncertainty of Radiated Emission Measurement (30 MHz ~ 1000 MHz)

Measuring Uncertainty for a Level of Confidence of 95% ($U = 2Uc(y)$)	2.54
---	------

Uncertainty of Radiated Emission Measurement (1 GHz ~ 40 GHz)

Measuring Uncertainty for a Level of Confidence of 95% ($U = 2Uc(y)$)	4.72
---	------



Appendix A. Photographs of EUT

Please refer to Sporton report number EP313006 as below.