

FCC SAR Test Report

APPLICANT : Brightstar Corporation
EQUIPMENT : GSM Mobile Phone
BRAND NAME : Avvio
MODEL NAME : Avvio 831
FCC ID : WVBA831
STANDARD : FCC 47 CFR Part 2 (2.1093)
ANSI/IEEE C95.1-1992
IEEE 1528-2003
FCC OET Bulletin 65 Supplement C (Edition 01-01)

The product completely tested on Aug. 07, 2012. We, SPORTON INTERNATIONAL (KUNSHAN) INC., would like to declare that the tested sample has been evaluated in accordance with the procedures and shown the compliance with the applicable technical standards.

The test results in this report apply exclusively to the tested model / sample. Without written approval of SPORTON INTERNATIONAL (KUNSHAN) INC., the test report shall not be reproduced except in full.

Reviewed by:



Jones Tsai / Manager



SPORTON INTERNATIONAL (KUNSHAN) INC.
No. 3-2, PingXiang Road, Kunshan, Jiangsu Province, P.R.C.



Table of Contents

1. Statement of Compliance	4
2. Administration Data	5
2.1 Testing Laboratory	5
2.2 Applicant	5
2.3 Manufacturer	5
2.4 Application Details	5
3. General Information	6
3.1 Description of Equipment Under Test (EUT)	6
3.2 Product Photos	7
3.3 Applied Standard	7
3.4 Device Category and SAR Limits	7
3.5 Test Conditions	7
4. Specific Absorption Rate (SAR)	8
4.1 Introduction	8
4.2 SAR Definition	8
5. SAR Measurement System	9
5.1 E-Field Probe	10
5.2 Data Acquisition Electronics (DAE)	11
5.3 Robot	11
5.4 Measurement Server	11
5.5 Phantom	12
5.6 Device Holder	12
5.7 Data Storage and Evaluation	13
5.8 Test Equipment List	15
6. Tissue Simulating Liquids	16
7. SAR Measurement Evaluation	18
7.1 Purpose of System Performance check	18
7.2 System Setup	18
7.3 Validation Results	19
8. EUT Testing Position	20
8.1 Define two imaginary lines on the handset	20
8.2 Cheek Position	21
8.3 Tilted Position	21
8.4 Body Worn Position	22
9. Measurement Procedures	23
9.1 Spatial Peak SAR Evaluation	23
9.2 Area & Zoom Scan Procedures	23
9.3 Volume Scan Procedures	24
9.4 SAR Averaged Methods	24
9.5 Power Drift Monitoring	24
10. SAR Test Configurations	25
10.1 Exposure Positions Consideration	25
10.2 Conducted RF Output Power (Unit: dBm)	27
11. SAR Test Results	30
11.1 Test Records for Head SAR Test	30
11.2 Test Records for Body-worn SAR Test	31
11.3 Simultaneous Multi-band Transmission Analysis	34
12. Uncertainty Assessment	38
13. References	40
Appendix A. Plots of System Performance Check	
Appendix B. Plots of SAR Measurement	
Appendix C. DASYS Calibration Certificate	
Appendix D. Product Photos	
Appendix E. Test Setup Photos	



Revision History

REPORT NO.	VERSION	DESCRIPTION	ISSUED DATE
FA251703	Rev. 01	Initial issue of report	Aug. 07, 2012



1. Statement of Compliance

The maximum results of Specific Absorption Rate (SAR) found during testing for **Brightstar Corporation** DUT: **GSM Mobile Phone**; **Brand Name: Avvio**; **Model Name: Avvio 831** are as follows.

<Standalone SAR>

Band	Position	SAR _{1g} (W/kg)
GSM850	Head	0.757
GSM1900	Head	0.776
WCDMA Band V	Head	0.704
WCDMA Band II	Head	1.370
WLAN 2.4G	Head	0.102
GSM850	Hotspot (1 cm Gap)	1.410
GSM1900	Hotspot (1 cm Gap)	0.998
WCDMA Band V	Hotspot (1 cm Gap)	0.689
WCDMA Band II	Hotspot (1 cm Gap)	0.665
WLAN 2.4G	Hotspot (1 cm Gap)	0.052
GSM850	Body-worn (1 cm Gap)	1.410
GSM1900	Body-worn (1 cm Gap)	0.998
WCDMA Band V	Body-worn (1 cm Gap)	0.689
WCDMA Band II	Body-worn (1 cm Gap)	0.665
WLAN 2.4G	Body-worn (1 cm Gap)	0.052

This device is in compliance with Specific Absorption Rate (SAR) for general population/uncontrolled exposure limits (1.6 W/kg) specified in FCC 47 CFR part 2 (2.1093) and ANSI/IEEE C95.1-1992, and had been tested in accordance with the measurement methods and procedures specified in IEEE 1528-2003 and FCC OET Bulletin 65 Supplement C (Edition 01-01).



2. Administration Data

2.1 Testing Laboratory

Test Site	SPORTON INTERNATIONAL (KUNSHAN) INC.
Test Site Location	No. 3-2, PingXiang Road, Kunshan, Jiangsu Province, P.R.C. TEL: +86-0512-5790-0158 FAX: +86-0512-5790-0958

2.2 Applicant

Company Name	Brightstar Corporation
Address	9725 NW 117th Ave., Miami, Florida, United States

2.3 Manufacturer

Company Name	Shanghai Huaqin Telecom Technology Co., Ltd.
Address	Building 12, 399 Keyuan Road, Pudong district, Shanghai, China

2.4 Application Details

Date of Start during the Test	May 18, 2012
Date of End during the Test	Aug. 07, 2012

3. General Information

3.1 Description of Equipment Under Test (EUT)

Product Feature & Specification	
EUT	GSM Mobile Phone
Brand Name	Avvio
Model Name	Avvio 831
FCC ID	WVBA831
IMEI Code	356087049974568
Tx Frequency	GSM850: 824.2 MHz ~ 848.8 MHz GSM1900: 1850.2 MHz ~ 1909.8 MHz WCDMA Band V: 826.4 MHz ~ 846.6 MHz WCDMA Band II: 1852.4 MHz ~ 1907.6 MHz WLAN2.4G: 2412 MHz ~ 2462 MHz Bluetooth: 2402 MHz ~ 2480 MHz
Rx Frequency	GSM850: 869.2 MHz ~ 893.8 MHz GSM1900: 1930.2 MHz ~ 1989.8 MHz WCDMA Band V: 871.4 MHz ~ 891.6 MHz WCDMA Band II: 1932.4 MHz ~ 1987.6 MHz WLAN2.4G: 2412 MHz ~ 2462 MHz Bluetooth: 2402 MHz ~ 2480 MHz
Maximum Average Output Power to Antenna	GSM850: 32.47 dBm GSM1900: 29.80 dBm WCDMA Band V: 22.57 dBm WCDMA Band II: 21.80 dBm 802.11b: 14.86 dBm 802.11g: 13.34 dBm Bluetooth: 4.24 dBm
Antenna Type	WWAN: Fixed Internal Antenna WLAN: PIFA Antenna Bluetooth: PIFA Antenna
HW Version	W92_MB_V4.0
SW Version	ZW92D_099A_V0_0_0
Type of Modulation	GSM: GMSK GPRS: GMSK EDGE: GMSK / 8PSK (Downlink Only) WCDMA: QPSK (Uplink) HSDPA: QPSK (Uplink) HSUPA: QPSK (Uplink) 802.11b: DSSS (BPSK / QPSK / CCK) 802.11g: OFDM (BPSK / QPSK / 16QAM / 64QAM) Bluetooth (1Mbps): GFSK Bluetooth EDR (2Mbps): $\pi/4$ -DQPSK Bluetooth EDR (3Mbps): 8-DPSK
Dual Transfer Mode (DTM) Category	Class B – EUT cannot support Packet Switched and Circuit Switched Network simultaneously but can automatically switch between Packet and Circuit Switched Network.
EUT Stage	Production Unit
Remark: The above EUT's information was declared by manufacturer. Please refer to the specifications or user's manual for more detailed description.	



3.2 Product Photos

Please refer to Appendix D.

3.3 Applied Standard

The Specific Absorption Rate (SAR) testing specification, method and procedure for this device is in accordance with the following standards:

- FCC 47 CFR Part 2 (2.1093)
- ANSI/IEEE C95.1-1992
- IEEE 1528-2003
- FCC OET Bulletin 65 Supplement C (Edition 01-01)
- FCC KDB 447498 D01 v04
- FCC KDB 648474 D01 v01r05
- FCC KDB 941225 D01 v02
- FCC KDB 941225 D03 v01
- FCC KDB 941225 D06 v01
- FCC KDB 248227 D01 v01r02

3.4 Device Category and SAR Limits

This device belongs to portable device category because its radiating structure is allowed to be used within 20 centimeters of the body of the user. Limit for General Population/Uncontrolled exposure should be applied for this device, it is 1.6 W/kg as averaged over any 1 gram of tissue.

3.5 Test Conditions

3.5.1 Ambient Condition

Ambient Temperature	20 to 24 °C
Humidity	< 60 %

3.5.2 Test Configuration

The device was controlled by using a base station emulator. Communication between the device and the emulator was established by air link. The distance between the EUT and the antenna of the emulator is larger than 50 cm and the output power radiated from the emulator antenna is at least 30 dB smaller than the output power of EUT. The EUT was set from the emulator to radiate maximum output power during all tests.

For WLAN SAR testing, WLAN engineering testing software installed on the EUT can provide continuous transmitting RF signal.

4. Specific Absorption Rate (SAR)

4.1 Introduction

SAR is related to the rate at which energy is absorbed per unit mass in an object exposed to a radio field. The SAR distribution in a biological body is complicated and is usually carried out by experimental techniques or numerical modeling. The standard recommends limits for two tiers of groups, occupational/controlled and general population/uncontrolled, based on a person's awareness and ability to exercise control over his or her exposure. In general, occupational/controlled exposure limits are higher than the limits for general population/uncontrolled.

4.2 SAR Definition

The SAR definition is the time derivative (rate) of the incremental energy (dW) absorbed by (dissipated in) an incremental mass (dm) contained in a volume element (dv) of a given density (ρ). The equation description is as below:

$$\text{SAR} = \frac{d}{dt} \left(\frac{dW}{dm} \right) = \frac{d}{dt} \left(\frac{dW}{\rho dv} \right)$$

SAR is expressed in units of Watts per kilogram (W/kg)

SAR measurement can be either related to the temperature elevation in tissue by

$$\text{SAR} = c \left(\frac{\delta T}{\delta t} \right)$$

Where: C is the specific heat capacity, δT is the temperature rise and δt is the exposure duration, or related to the electrical field in the tissue by

$$\text{SAR} = \frac{\sigma |E|^2}{\rho}$$

Where: σ is the conductivity of the tissue, ρ is the mass density of the tissue and E is the RMS electrical field strength.

However for evaluating SAR of low power transmitter, electrical field measurement is typically applied.

5. SAR Measurement System

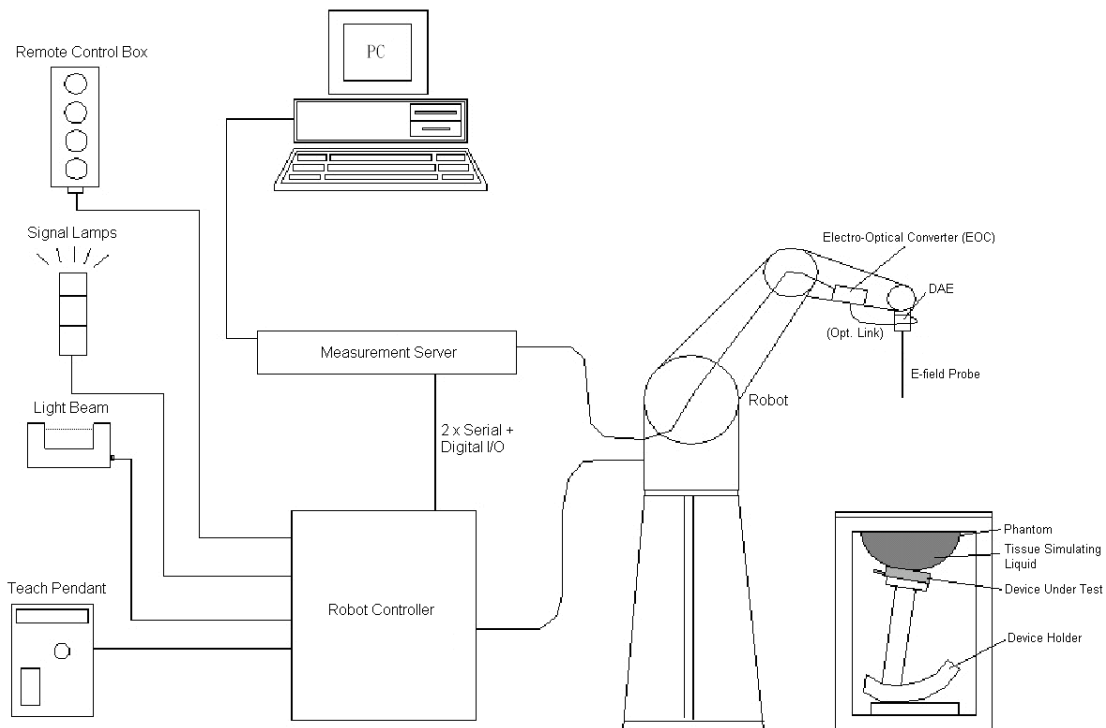

Fig 5.1 SPEAG DASY System Configurations

The DASY system for performance compliance tests is illustrated above graphically. This system consists of the following items:

- A standard high precision 6-axis robot with controller, a teach pendant and software
- A data acquisition electronic (DAE) attached to the robot arm extension
- A dosimetric probe equipped with an optical surface detector system
- The electro-optical converter (EOC) performs the conversion between optical and electrical signals
- A measurement server performs the time critical tasks such as signal filtering, control of the robot operation and fast movement interrupts.
- A probe alignment unit which improves the accuracy of the probe positioning
- A computer operating Windows XP
- DASY software
- Remote control with teach pendant and additional circuitry for robot safety such as warning lamps, etc.
- The SAM twin phantom
- A device holder
- Tissue simulating liquid
- Dipole for evaluating the proper functioning of the system

Component details are described in in the following sub-sections.

5.1 E-Field Probe

The SAR measurement is conducted with the dosimetric probe (manufactured by SPEAG). The probe is specially designed and calibrated for use in liquid with high permittivity. The dosimetric probe has special calibration in liquid at different frequency. This probe has a built in optical surface detection system to prevent from collision with phantom.

5.1.1 E-Field Probe Specification

<ES3DV3>

Construction	Symmetrical design with triangular core Interleaved sensors Built-in shielding against static charges PEEK enclosure material (resistant to organic solvents, e.g., DGBE)	 <p>Fig 5.2 Photo of ES3DV3</p>
Frequency	10 MHz to 4 GHz; Linearity: ± 0.2 dB	
Directivity	± 0.2 dB in HSL (rotation around probe axis) ± 0.3 dB in tissue material (rotation normal to probe axis)	
Dynamic Range	5 μ W/g to 100 mW/g; Linearity: ± 0.2 dB	
Dimensions	Overall length: 337 mm (Tip: 20 mm) Tip diameter: 3.9 mm (Body: 12 mm) Distance from probe tip to dipole centers: 2.0 mm	

5.1.2 E-Field Probe Calibration

Each probe needs to be calibrated according to a dosimetric assessment procedure with accuracy better than $\pm 10\%$. The spherical isotropy shall be evaluated and within ± 0.25 dB. The sensitivity parameters (NormX, NormY, and NormZ), the diode compression parameter (DCP) and the conversion factor (ConvF) of the probe are tested. The calibration data can be referred to appendix C of this report.

5.2 Data Acquisition Electronics (DAE)

The data acquisition electronics (DAE) consists of a highly sensitive electrometer-grade preamplifier with auto-zeroing, a channel and gain-switching multiplexer, a fast 16 bit AD-converter and a command decoder and control logic unit. Transmission to the measurement server is accomplished through an optical downlink for data and status information as well as an optical uplink for commands and the clock. The input impedance of the DAE is 200 MOhm; the inputs are symmetrical and floating. Common mode rejection is above 80 dB.



Fig 5.3 Photo of DAE

5.3 Robot

The SPEAG DASY system uses the high precision robots (DASY5: TX90XL) type from Stäubli SA (France). For the 6-axis controller system, the robot controller version (DASY5: CS8c) from Stäubli is used. The Stäubli robot series have many features that are important for our application:

- High precision (repeatability ± 0.035 mm)
- High reliability (industrial design)
- Jerk-free straight movements
- Low ELF interference (the closed metallic construction shields against motor control fields)



Fig 5.4 Photo of DASY5

5.4 Measurement Server

The measurement server is based on a PC/104 CPU board with CPU (DASY5: 400 MHz, Intel Celeron), chipdisk (DASY5: 128 MB), RAM (DASY5: 128 MB). The necessary circuits for communication with the DAE electronic box, as well as the 16 bit AD converter system for optical detection and digital I/O interface are contained on the DASY I/O board, which is directly connected to the PC/104 bus of the CPU board.

The measurement server performs all the real-time data evaluation for field measurements and surface detection, controls robot movements and handles safety operations.



Fig 5.5 Photo of Server for DASY5

5.5 Phantom

<SAM Twin Phantom>

Shell Thickness	2 ± 0.2 mm; Center ear point: 6 ± 0.2 mm	
Filling Volume	Approx. 25 liters	
Dimensions	Length: 1000 mm; Width: 500 mm; Height: adjustable feet	
Measurement Areas	Left Hand, Right Hand, Flat Phantom	

Fig 5.6 Photo of SAM Phantom

The bottom plate contains three pair of bolts for locking the device holder. The device holder positions are adjusted to the standard measurement positions in the three sections. A white cover is provided to tap the phantom during off-periods to prevent water evaporation and changes in the liquid parameters. On the phantom top, three reference markers are provided to identify the phantom position with respect to the robot.

5.6 Device Holder

<Device Holder for SAM Twin Phantom>

The SAR in the phantom is approximately inversely proportional to the square of the distance between the source and the liquid surface. For a source at 5 mm distance, a positioning uncertainty of ± 0.5 mm would produce a SAR uncertainty of ± 20 %. Accurate device positioning is therefore crucial for accurate and repeatable measurements. The positions in which the devices must be measured are defined by the standards.

The DASY device holder is designed to cope with different positions given in the standard. It has two scales for the device rotation (with respect to the body axis) and the device inclination (with respect to the line between the ear reference points). The rotation center for both scales is the ear reference point (EPR). Thus the device needs no repositioning when changing the angles.

The DASY device holder is constructed of low-loss POM material having the following dielectric parameters: relative permittivity $\epsilon = 3$ and loss tangent $\delta = 0.02$. The amount of dielectric material has been reduced in the closest vicinity of the device, since measurements have suggested that the influence of the clamp on the test results could thus be lowered.



Fig 5.7 Device Holder

5.7 Data Storage and Evaluation

5.7.1 Data Storage

The DASY software stores the assessed data from the data acquisition electronics as raw data (in microvolt readings from the probe sensors), together with all the necessary software parameters for the data evaluation (probe calibration data, liquid parameters and device frequency and modulation data) in measurement files. The post-processing software evaluates the desired unit and format for output each time the data is visualized or exported. This allows verification of the complete software setup even after the measurement and allows correction of erroneous parameter settings. For example, if a measurement has been performed with an incorrect crest factor parameter in the device setup, the parameter can be corrected afterwards and the data can be reevaluated.

The measured data can be visualized or exported in different units or formats, depending on the selected probe type (e.g., [V/m], [A/m], [mW/g]). Some of these units are not available in certain situations or give meaningless results, e.g., a SAR-output in a non-lose media, will always be zero. Raw data can also be exported to perform the evaluation with other software packages.

5.7.2 Data Evaluation

The DASY post-processing software (SEMCAD) automatically executes the following procedures to calculate the field units from the microvolt readings at the probe connector. The parameters used in the evaluation are stored in the configuration modules of the software :

Probe parameters :	- Sensitivity	Norm _i , a ₁₀ , a ₁₁ , a ₁₂
	- Conversion factor	ConvF _i
	- Diode compression point	dcp _i
Device parameters :	- Frequency	f
	- Crest factor	cf
Media parameters :	- Conductivity	σ
	- Density	ρ

These parameters must be set correctly in the software. They can be found in the component documents or they can be imported into the software from the configuration files issued for the DASY components. In the direct measuring mode of the multi-meter option, the parameters of the actual system setup are used. In the scan visualization and export modes, the parameters stored in the corresponding document files are used.

The first step of the evaluation is a linearization of the filtered input signal to account for the compression characteristics of the detector diode. The compensation depends on the input signal, the diode type and the DC-transmission factor from the diode to the evaluation electronics. If the exciting field is pulsed, the crest factor of the signal must be known to correctly compensate for peak power.

The formula for each channel can be given as :

$$V_i = U_i + U_i^2 \cdot \frac{cf}{dcp_i}$$

with V_i = compensated signal of channel i , ($i = x, y, z$)
 U_i = input signal of channel i , ($i = x, y, z$)
 cf = crest factor of exciting field (DASY parameter)
 dcp_i = diode compression point (DASY parameter)

From the compensated input signals, the primary field data for each channel can be evaluated :

$$\text{E-field Probes : } E_i = \sqrt{\frac{V_i}{\text{Norm}_i \cdot \text{ConvF}}}$$

$$\text{H-field Probes : } H_i = \sqrt{V_i \cdot \frac{a_{i0} + a_{i1}f + a_{i2}f^2}{f}}$$

with V_i = compensated signal of channel i , ($i = x, y, z$)
 Norm_i = sensor sensitivity of channel i , ($i = x, y, z$), $\mu\text{V}/(\text{V/m})^2$ for E-field Probes
 ConvF = sensitivity enhancement in solution
 a_{ij} = sensor sensitivity factors for H-field probes
 f = carrier frequency [GHz]
 E_i = electric field strength of channel i in V/m
 H_i = magnetic field strength of channel i in A/m

The RSS value of the field components gives the total field strength (Hermitian magnitude) :

$$E_{\text{tot}} = \sqrt{E_x^2 + E_y^2 + E_z^2}$$

The primary field data are used to calculate the derived field units.

$$\text{SAR} = E_{\text{tot}}^2 \cdot \frac{\sigma}{\rho \cdot 1000}$$

with SAR = local specific absorption rate in mW/g
 E_{tot} = total field strength in V/m
 σ = conductivity in [mho/m] or [Siemens/m]
 ρ = equivalent tissue density in g/cm^3

Note that the density is set to 1, to account for actual head tissue density rather than the density of the tissue simulating liquid.



5.8 Test Equipment List

Manufacturer	Name of Equipment	Type/Model	Serial Number	Calibration	
				Last Cal.	Due Date
SPEAG	835MHz System Validation Kit	D835V2	4d091	Nov. 18, 2011	Nov. 17, 2012
SPEAG	1900MHz System Validation Kit	D1900V2	5d118	Nov. 21, 2011	Nov. 20, 2012
SPEAG	2450MHz System Validation Kit	D2450V2	736	Jul. 25, 2011	Jul. 24, 2014
SPEAG	Data Acquisition Electronics	DAE4	1303	Nov. 10, 2011	Nov. 09, 2012
SPEAG	Dosimetric E-Field Probe	ES3DV3	3270	Sep. 12, 2011	Sep. 11, 2012
SPEAG	SAM Twin Phantom	QD 000 P40 CD	TP-1670	NCR	NCR
SPEAG	SAM Twin Phantom	QD 000 P40 CD	TP-1671	NCR	NCR
SPEAG	Phone Positioner	N/A	N/A	NCR	NCR
Anritsu	Radio Communication Analyzer	MT8820C	6201091028	Jun. 10, 2012	Jun. 09, 2013
Agilent	Base Station	E5515C	MY50267224	Dec. 29, 2011	Dec. 28, 2012
Agilent	ENA Series Network Analyzer	E5071C	MY46111157	Apr. 13, 2012	Apr. 12, 2013
Agilent	Dielectric Probe Kit	85070E	MY44300475	NCR	NCR
R&S	Signal Generator	SMR40	100455	Dec. 30, 2011	Dec. 29, 2012
AR	Amplifier	551G4	333096	NCR	NCR
Agilent	Power Meter	E4416A	MY45101555	Aug. 23, 2011	Aug. 22, 2012
Agilent	Power Sensor	E9327A	MY44421198	Aug. 23, 2011	Aug. 22, 2012
ARRA	Power Divider	A3200-2	N/A	NA	NA
MCL	Attenuation	BW-S10W5	N/A	NA	NA
R&S	Spectrum Analyzer	FSP30	101400	Jun. 01, 2012	May 31, 2013

Table 5.1 Test Equipment List

Note: The calibration certificate of DASY can be referred to appendix C of this report.

6. Tissue Simulating Liquids

For the measurement of the field distribution inside the SAM phantom with DASY, the phantom must be filled with around 25 liters of homogeneous body tissue simulating liquid. For head SAR testing, the liquid height from the ear reference point (ERP) of the phantom to the liquid top surface is larger than 15 cm, which is shown in Fig. 6.1. For body SAR testing, the liquid height from the center of the flat phantom to the liquid top surface is larger than 15 cm, which is shown in Fig. 6.2.



Fig 6.1 Photo of Liquid Height for Head SAR



Fig 6.2 Photo of Liquid Height for Body SAR

The following table gives the recipes for tissue simulating liquid.

Frequency (MHz)	Water (%)	Sugar (%)	Cellulose (%)	Salt (%)	Preventol (%)	DGBE (%)	Conductivity (σ)	Permittivity (ϵ_r)
For Head								
835	40.3	57.9	0.2	1.4	0.2	0	0.90	41.5
1800, 1900, 2000	55.2	0	0	0.3	0	44.5	1.40	40.0
2450	55.0	0	0	0	0	45.0	1.80	39.2
For Body								
835	50.8	48.2	0	0.9	0.1	0	0.97	55.2
1800, 1900, 2000	70.2	0	0	0.4	0	29.4	1.52	53.3
2450	68.6	0	0	0	0	31.4	1.95	52.7

Table 6.1 Recipes of Tissue Simulating Liquid



The dielectric parameters of the liquids were verified prior to the SAR evaluation using an Agilent 85070D Dielectric Probe Kit and an Agilent Network Analyzer.

The following table shows the measuring results for simulating liquid.

Freq. (MHz)	Liquid Type	Temp. (°C)	Conductivity (σ)	Permittivity (ϵ_r)	Conductivity Target (σ)	Permittivity Target (ϵ_r)	Delta (σ) (%)	Delta (ϵ_r) (%)	Limit (%)	Date
835	Head	21.7	0.928	42.73	0.90	41.5	3.11	2.96	±5	May 18, 2012
835	Body	21.4	0.977	54.388	0.97	55.2	0.72	-1.47	±5	Aug. 06, 2012
1900	Head	21.5	1.419	40.609	1.40	40.0	1.36	1.52	±5	May 18, 2012
1900	Head	21.5	1.415	40.527	1.40	40.0	1.07	1.32	±5	May 25, 2012
1900	Body	21.5	1.519	53.569	1.52	53.3	-0.07	0.50	±5	Aug. 06, 2012
2450	Head	21.3	1.834	39.654	1.80	39.2	1.89	1.16	±5	Jul. 23, 2012
2450	Body	21.6	1.951	53.859	1.95	52.7	0.05	2.20	±5	Aug. 07, 2012

Table 6.2 Measuring Results for Simulating Liquid

7. SAR Measurement Evaluation

Each DASY system is equipped with one or more system validation kits. These units, together with the predefined measurement procedures within the DASY software, enable the user to conduct the system performance check and system validation. System validation kit includes a dipole, tripod holder to fix it underneath the flat phantom and a corresponding distance holder.

7.1 Purpose of System Performance check

The system performance check verifies that the system operates within its specifications. System and operator errors can be detected and corrected. It is recommended that the system performance check be performed prior to any usage of the system in order to guarantee reproducible results. The system performance check uses normal SAR measurements in a simplified setup with a well characterized source. This setup was selected to give a high sensitivity to all parameters that might fail or vary over time. The system check does not intend to replace the calibration of the components, but indicates situations where the system uncertainty is exceeded due to drift or failure.

7.2 System Setup

In the simplified setup for system evaluation, the EUT is replaced by a calibrated dipole and the power source is replaced by a continuous wave that comes from a signal generator. The calibrated dipole must be placed beneath the flat phantom section of the SAM twin phantom with the correct distance holder. The distance holder should touch the phantom surface with a light pressure at the reference marking and be oriented parallel to the long side of the phantom. The equipment setup is shown below:

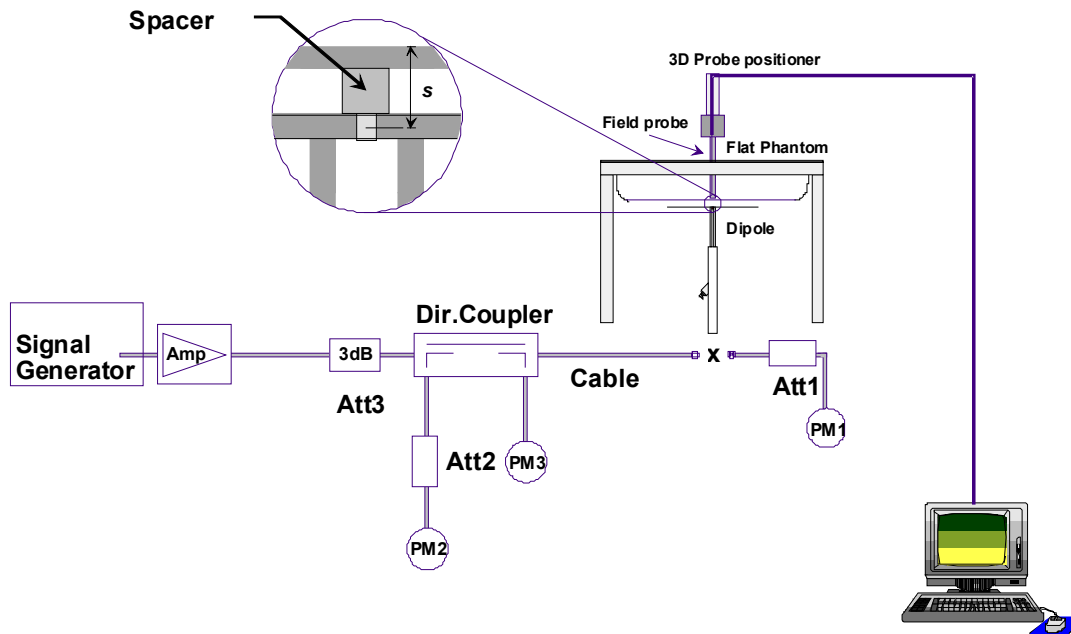

Fig 7.1 System Setup for System Evaluation

1. Signal Generator
2. Amplifier
3. Directional Coupler
4. Power Meter
5. Calibrated Dipole

The output power on dipole port must be calibrated to 24 dBm (250 mW) before dipole is connected.

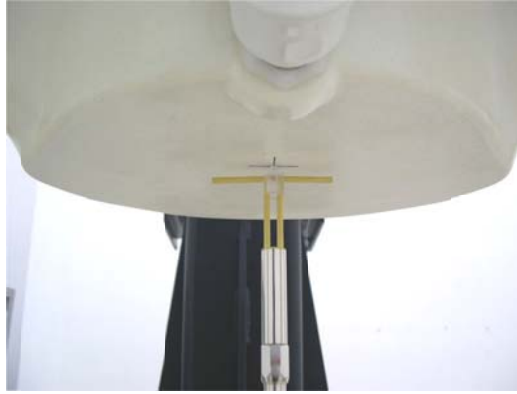

Fig 7.2 Photo of Dipole Setup

7.3 Validation Results

Comparing to the original SAR value provided by SPEAG, the validation data should be within its specification of 10 %. Table 7.1 shows the target SAR and measured SAR after normalized to 1W input power. The table below indicates the system performance check can meet the variation criterion and the plots can be referred to Appendix A of this report.

Measurement Date	Frequency (MHz)	Liquid Type	Targeted SAR _{1g} (W/kg)	Measured SAR _{1g} (W/kg)	Normalized SAR _{1g} (W/kg)	Deviation (%)
May 18, 2012	835	Head	9.40	2.48	9.92	5.53
Aug. 06, 2012	835	Body	9.42	2.36	9.44	0.21
May 18, 2012	1900	Head	40.3	10.3	41.20	2.23
May 25, 2012	1900	Head	40.3	9.71	38.84	-3.62
Aug. 06, 2012	1900	Body	41.8	10.6	42.40	1.44
Jul. 23, 2012	2450	Head	54.80	13.3	53.20	-2.92
Aug. 07, 2012	2450	Body	52.30	12.9	51.60	-1.34

Table 7.1 Target and Measurement SAR after Normalized

8. EUT Testing Position

This EUT was tested in ten different positions. They are right cheek, right tilted, left cheek, left tilted, Front of the EUT with phantom 1 cm gap, Back of the EUT with phantom 1 cm gap, Top Side of the EUT with phantom 1 cm gap, Bottom Side of the EUT with phantom 1 cm gap, Right Side of the EUT with phantom 1 cm gap, and Left Side of the EUT with phantom 1 cm gap, as illustrated below:

8.1 Define two imaginary lines on the handset

- The vertical centerline passes through two points on the front side of the handset - the midpoint of the width w_t of the handset at the level of the acoustic output, and the midpoint of the width w_b of the bottom of the handset.
- The horizontal line is perpendicular to the vertical centerline and passes through the center of the acoustic output. The horizontal line is also tangential to the face of the handset at point A.
- The two lines intersect at point A. Note that for many handsets, point A coincides with the center of the acoustic output; however, the acoustic output may be located elsewhere on the horizontal line. Also note that the vertical centerline is not necessarily parallel to the front face of the handset, especially for clamshell handsets, handsets with flip covers, and other irregularly shaped handsets.

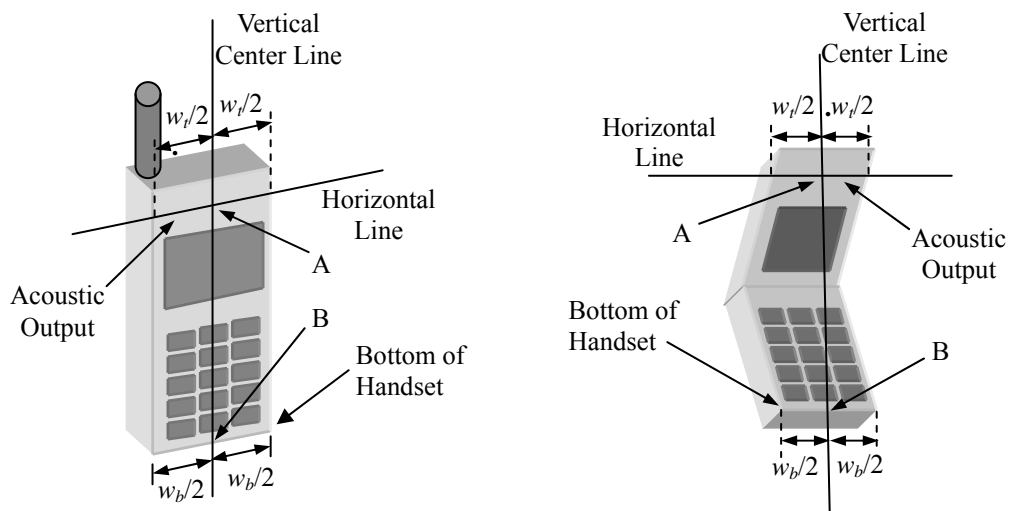

Fig 8.1 Illustration for Handset Vertical and Horizontal Reference Lines

8.2 Cheek Position

- (a) To position the device with the vertical center line of the body of the device and the horizontal line crossing the center piece in a plane parallel to the sagittal plane of the phantom. While maintaining the device in this plane, align the vertical center line with the reference plane containing the three ear and mouth reference point (M: Mouth, RE: Right Ear, and LE: Left Ear) and align the center of the ear piece with the line RE-LE.
- (b) To move the device towards the phantom with the ear piece aligned with the line LE-RE until the phone touched the ear. While maintaining the device in the reference plane and maintaining the phone contact with the ear, move the bottom of the phone until any point on the front side is in contact with the cheek of the phantom or until contact with the ear is lost (see Fig. 9.2).

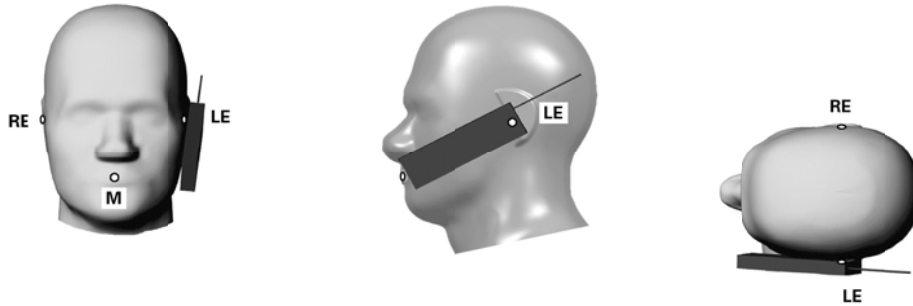

Fig 8.2 Illustration for Cheek Position

8.3 Tilted Position

- (a) To position the device in the “cheek” position described above.
- (b) While maintaining the device the reference plane described above and pivoting against the ear, moves it outward away from the mouth by an angle of 15 degrees or until contact with the ear is lost (see Fig. 9.3).

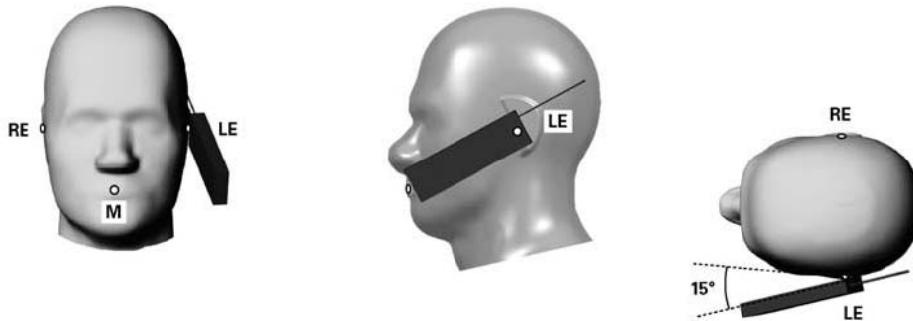

Fig 8.3 Illustration for Tilted Position

8.4 Body Worn Position

- (a) To position the device parallel to the phantom surface with either keypad up or down.
- (b) To adjust the device parallel to the flat phantom.
- (c) To adjust the distance between the device surface and the flat phantom to 1 cm.

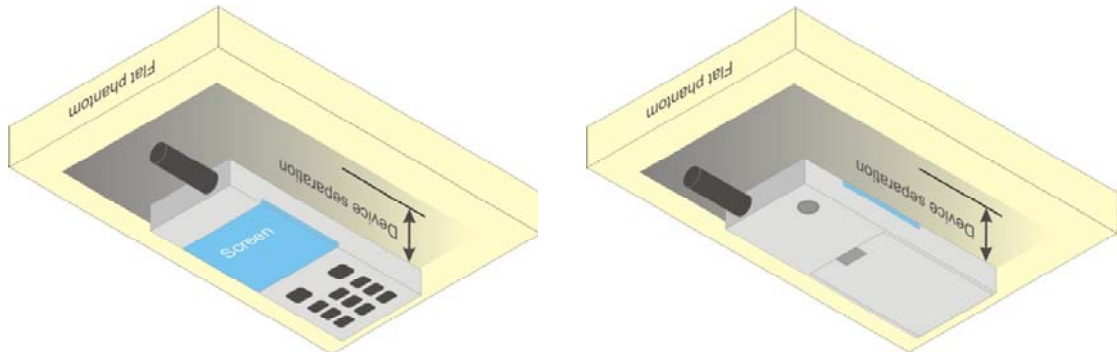

Fig 8.4 Illustration for Body Worn Position

<EUT Setup Photos>

Please refer to Appendix E for the test setup photos.

9. Measurement Procedures

The measurement procedures are as follows:

- (a) Use base station simulator (if applicable) or engineering software to transmit RF power continuously (continuous Tx) in the highest power channel.
- (b) Keep EUT to radiate maximum output power or 100% EUTy factor (if applicable)
- (c) Measure output power through RF cable and power meter.
- (d) Place the EUT in the positions as Appendix E demonstrates.
- (e) Set scan area, grid size and other setting on the DASY software.
- (f) Measure SAR results for the highest power channel on each testing position.
- (g) Find out the largest SAR result on these testing positions of each band
- (h) Measure SAR results for other channels in worst SAR testing position if the SAR of highest power channel is larger than 0.8 W/kg

According to the test standard, the recommended procedure for assessing the peak spatial-average SAR value consists of the following steps:

- (a) Power reference measurement
- (b) Area scan
- (c) Zoom scan
- (d) Power drift measurement

9.1 Spatial Peak SAR Evaluation

The procedure for spatial peak SAR evaluation has been implemented according to the test standard. It can be conducted for 1g and 10g, as well as for user-specific masses. The DASY software includes all numerical procedures necessary to evaluate the spatial peak SAR value.

The base for the evaluation is a "cube" measurement. The measured volume must include the 1g and 10g cubes with the highest averaged SAR values. For that purpose, the center of the measured volume is aligned to the interpolated peak SAR value of a previously performed area scan.

The entire evaluation of the spatial peak values is performed within the post-processing engine (SEMCAD). The system always gives the maximum values for the 1g and 10g cubes. The algorithm to find the cube with highest averaged SAR is divided into the following stages:

- (a) Extraction of the measured data (grid and values) from the Zoom Scan
- (b) Calculation of the SAR value at every measurement point based on all stored data (A/D values and measurement parameters)
- (c) Generation of a high-resolution mesh within the measured volume
- (d) Interpolation of all measured values from the measurement grid to the high-resolution grid
- (e) Extrapolation of the entire 3-D field distribution to the phantom surface over the distance from sensor to surface
- (f) Calculation of the averaged SAR within masses of 1g and 10g

9.2 Area & Zoom Scan Procedures

First Area Scan is used to locate the approximate location(s) of the local peak SAR value(s). The measurement grid within an Area Scan is defined by the grid extent, grid step size and grid offset. Next, in order to determine the EM field distribution in a three-dimensional spatial extension, Zoom Scan is required. The Zoom Scan measures 5x5x7 points with step size 8, 8 and 5 mm for 300 MHz to 3 GHz, and 8x8x8 points with step size 4, 4 and 2.5 mm for 3 GHz to 6 GHz. The Zoom Scan is performed around the highest E-field value to determine the averaged SAR-distribution over 10 g.



9.3 Volume Scan Procedures

The volume scan is used to assess overlapping SAR distributions for antennas transmitting in different frequency bands. It is equivalent to an oversized zoom scan used in standalone measurements. The measurement volume will be used to enclose all the simultaneous transmitting antennas. For antennas transmitting simultaneously in different frequency bands, the volume scan is measured separately in each frequency band. In order to sum correctly to compute the 1g aggregate SAR, the EUT remains in the same test position for all measurements and all volume scans use the same spatial resolution and grid spacing (step-size is 4, 4 and 2.5 mm). When all volume scans are completed, the software, SEMCAD postprocessor can combine and subsequently superpose these measurement data to calculate the multiband SAR.

9.4 SAR Averaged Methods

In DASy, the interpolation and extrapolation are both based on the modified Quadratic Shepard's method. The interpolation scheme combines a least-square fitted function method and a weighted average method which are the two basic types of computational interpolation and approximation.

Extrapolation routines are used to obtain SAR values between the lowest measurement points and the inner phantom surface. The extrapolation distance is determined by the surface detection distance and the probe sensor offset. The uncertainty increases with the extrapolation distance. To keep the uncertainty within 1% for the 1 g and 10 g cubes, the extrapolation distance should not be larger than 5 mm.

9.5 Power Drift Monitoring

All SAR testing is under the EUT installed full charged battery and transmit maximum output power. In DASy measurement software, the power reference measurement and power drift measurement procedures are used for monitoring the power drift of EUT during SAR test. Both these procedures measure the field at a specified reference position before and after the SAR testing. The software will calculate the field difference in dB. If the power drift more than 5%, the SAR will be retested.

10. SAR Test Configurations

10.1 Exposure Positions Consideration

Length: 11.0 cm

Width: 6.1 cm

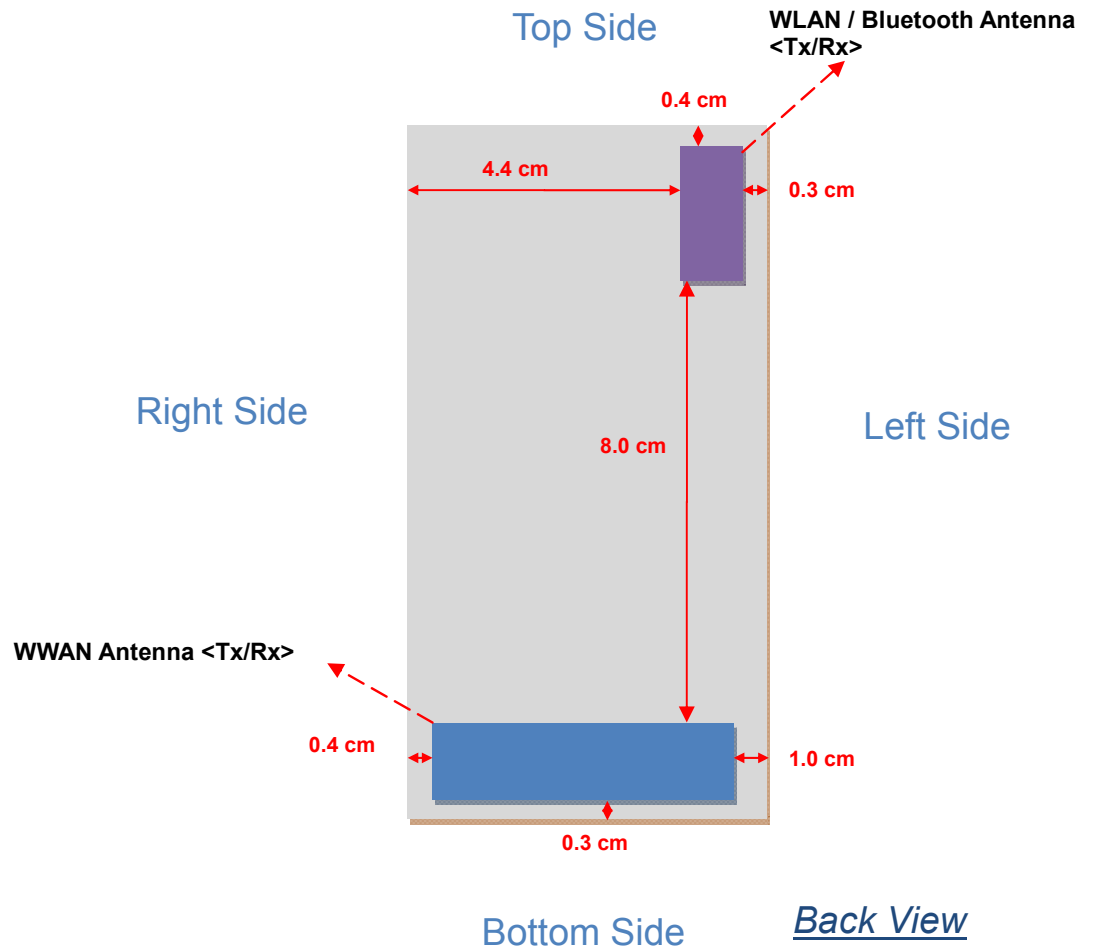

Antennas	Wireless Interface
WWAN Antenna (Tx / Rx)	GSM850, GSM1900 WCDMA Band II, WCDMA Band V
WLAN & Bluetooth Antenna (Tx / Rx)	WLAN 2.4GHz Bluetooth



Sides for SAR tests; Hotspot mode						
Test distance: 10 mm						
Antennas	Back	Front	Top Side	Bottom Side	Right Side	Left Side
WWAN	YES	YES	NO	YES	YES	YES
WLAN & Bluetooth	YES	YES	YES	NO	NO	YES

Note:

1. Head/Body-worn/Hotspot mode SAR assessments are required.
2. Referring to KDB 941225 D06, when the overall device length and width are $\geq 9\text{cm} \times 5\text{cm}$, the test distance is 10 mm. SAR must be measured for all sides and surfaces with a transmitting antenna located within 25mm from that surface or edge.
3. For WWAN antenna, SAR measurements at Top side are not required since the distance between EUT and flat phantom $> 25\text{mm}$.
4. For WLAN & Bluetooth antenna, SAR measurements Bottom/Right sides are not required since the distance between EUT and flat phantom $> 25\text{mm}$.
5. Per KDB 648474 D01, Bluetooth output power $(4.24 \text{ dBm}) \leq 2 \cdot P_{\text{Ref}}$ and the distance to other antennas $\geq 5\text{cm}$, therefore, stand-alone SAR is not required.

10.2 Conducted RF Output Power (Unit: dBm)

<GSM>

Burst Average Power						
Band	GSM850			GSM1900		
Channel	128	189	251	512	661	810
Frequency (MHz)	824.2	836.4	848.8	1850.2	1880.0	1909.8
GSM (1 Uplink)	32.47	32.40	32.31	28.96	29.41	29.80
GPRS 8 (1 Uplink) – CS1	32.46	32.39	32.30	28.93	29.40	29.78
GPRS 10 (2 Uplink) – CS1	31.57	31.50	31.40	27.99	28.46	28.88
GPRS 11 (3 Uplink) – CS1	29.95	29.86	29.75	26.25	26.71	27.12
GPRS 12 (4 Uplink) – CS1	29.16	29.04	28.90	25.44	25.94	26.33

Source-Based Time-Averaged Power						
Band	GSM850			GSM1900		
Channel	128	189	251	512	661	810
Frequency (MHz)	824.2	836.4	848.8	1850.2	1880.0	1909.8
GSM (1 Uplink)	23.47	23.40	23.31	19.96	20.41	20.80
GPRS 8 (1 Uplink) – CS1	23.46	23.39	23.30	19.93	20.40	20.78
GPRS 10 (2 Uplink) – CS1	25.57	25.50	25.40	21.99	22.46	22.88
GPRS 11 (3 Uplink) – CS1	25.69	25.60	25.49	21.99	22.45	22.86
GPRS 12 (4 Uplink) – CS1	26.16	26.04	25.90	22.44	22.94	23.33

Remark: The source-based time-averaged power is linearly scaled the maximum burst averaged power based on time slots. The calculated method are shown as below:

Source based time averaged power = Maximum burst averaged power (1 Uplink) - 9 dB
 Source based time averaged power = Maximum burst averaged power (2 Uplink) - 6 dB
 Source based time averaged power = Maximum burst averaged power (3 Uplink) - 4.26 dB
 Source based time averaged power = Maximum burst averaged power (4 Uplink) - 3 dB

Note:

1. For Head SAR testing, GSM should be evaluated, therefore the EUT was set in GSM for GSM850 and set in GSM for GSM1900 due to its highest source-based time-average power.
2. For Body SAR testing, GPRS should be evaluated, therefore the EUT was set in GPRS 12 for GSM850 and set in GPRS 12 for GSM1900 due to its highest source-based time-average power.
3. Per 2010/10 workshop, the maximum output power channel is used for SAR testing and for further SAR test reduction.
4. The DUT do not support DTM function.



<WCDMA>

Band	WCDMA Band V			WCDMA Band II		
Channel	4132	4182	4233	9262	9400	9538
Frequency (MHz)	826.4	836.4	846.6	1852.4	1880.0	1907.6
AMR	22.55	22.56	22.46	21.75	21.49	21.78
RMC 12.2K	22.56	22.57	22.49	21.75	21.58	21.80
HSDPA Subtest-1	22.49	22.50	22.40	21.71	21.49	21.77
HSDPA Subtest-2	22.50	22.52	22.41	21.63	21.45	21.74
HSDPA Subtest-3	22.02	22.01	21.95	21.26	21.25	21.47
HSDPA Subtest-4	22.00	21.98	21.90	21.25	20.85	21.42
HSUPA Subtest-1	21.29	21.26	21.21	20.15	19.92	20.19
HSUPA Subtest-2	20.02	19.94	19.89	18.86	18.67	18.85
HSUPA Subtest-3	20.45	20.49	20.40	19.20	18.92	19.21
HSUPA Subtest-4	19.97	20.02	19.89	19.32	19.12	19.42
HSUPA Subtest-5	21.48	21.51	21.38	20.33	20.17	20.43

MPR (dB)							
3GPP MPR	Subtest	WCDMA Band V			WCDMA Band II		
0	HSDPA Subtest-1	0.00	0.00	0.00	0.00	0.00	0.00
0	HSDPA Subtest-2	-0.01	-0.02	-0.01	0.08	0.04	0.03
≤ 0.5	HSDPA Subtest-3	0.47	0.49	0.45	0.45	0.24	0.30
≤ 0.5	HSDPA Subtest-4	0.49	0.52	0.50	0.46	0.64	0.35
0	HSUPA Subtest-1	0.19	0.25	0.17	0.18	0.25	0.24
≤ 2	HSUPA Subtest-2	1.46	1.57	1.49	1.47	1.50	1.58
≤ 1	HSUPA Subtest-3	1.03	1.02	0.98	1.13	1.25	1.22
≤ 2	HSUPA Subtest-4	1.51	1.49	1.49	1.01	1.05	1.01
0	HSUPA Subtest-5	0.00	0.00	0.00	0.00	0.00	0.00

Note:

- For Head SAR, per KDB 941225 D01, RMC 12.2kbps setting is used to evaluate SAR. If AMR 12.2kbps power is < 1/4 dB higher than RMC, SAR tests with AMR 12.2kbps can be excluded.
- For Body SAR, per KDB 941225 D01, RMC 12.2kbps setting is used to evaluate SAR. If HSDPA subset-1 and HSUPA subset-5 output power is < 1/4 dB higher than RMC, and SAR with RMC 12.2kbps setting is ≤ 1.2W/kg, HSDPA and HSUPA SAR evaluation can be excluded.
- EUT is designed to follow the MPR of 3GPP Table 5.2B.1 specification. In production units, MPR result deviation from 3GPP is expected; the implementation and expected deviation is detailed in tune-up procedure exhibit.

<WLAN 2.4GHz>

Mode	Channel	Frequency (MHz)	Average power (dBm)			
			Data Rate (bps)			
			1M	2M	5.5M	11M
802.11b	CH 01	2412	14.86	14.81	14.68	14.85
	CH 06	2437	14.73	14.64	14.61	14.65
	CH 11	2462	14.27	14.13	14.18	14.26

Mode	Channel	Frequency (MHz)	Average power (dBm)							
			Data Rate (bps)							
			6M	9M	12M	18M	24M	36M	48M	54M
802.11g	CH 01	2412	13.34	13.27	13.26	13.33	13.20	13.20	13.26	13.33
	CH 06	2437	13.20	13.28	13.26	13.25	13.27	13.26	13.31	13.31
	CH 11	2462	12.97	12.90	12.93	13.00	12.93	12.89	12.93	12.91

Note:

1. Per KDB 248227, choose the highest output power channel to test SAR and determine further SAR exclusion
2. Per KDB 248227, 11g output power is less than 1/4 dB higher than 11b mode, thus the SAR can be excluded.
3. For each frequency band, testing at higher data rates and higher order modulations is not required when the maximum average output power for each of these configurations is less than 1/4 dB higher than those measured at the lowest data rate.

<Bluetooth>

Mode	Channel	Frequency (MHz)	Average power (dBm)								
			Data Rate								
			DH1	DH3	DH5	2DH1	2DH3	2DH5	3DH1	3DH3	3DH5
Bluetooth	CH 00	2402 MHz	3.79	3.86	3.91	1.76	1.43	1.38	1.64	1.25	1.26
	CH 39	2441 MHz	3.95	4.22	4.24	2.01	1.71	1.64	1.93	1.55	1.57
	CH 78	2480 MHz	3.57	3.69	3.75	1.46	1.23	1.09	1.61	0.98	1.01

Note: Per KDB 447498, Bluetooth SAR is excluded due to highest output power (4.24 dBm) ≤ 2P_{ref} (GHz) mW, where 2P_{ref} (GHz) = 24mW = 13.8dBm.

11. SAR Test Results

11.1 Test Records for Head SAR Test

<GSM>

Plot No.	Band	Mode	Test Position	Ch.	SAR _{1g} (W/kg)
1	GSM850	GSM	Right Cheek	128	0.711
2	GSM850	GSM	Right Tilted	128	0.424
3	GSM850	GSM	Left Cheek	128	0.757
4	GSM850	GSM	Left Tilted	128	0.413
9	GSM1900	GSM	Right Cheek	810	0.701
10	GSM1900	GSM	Right Tilted	810	0.151
11	GSM1900	GSM	Left Cheek	810	0.776
12	GSM1900	GSM	Left Tilted	810	0.155

Note: Per KDB 447498, if the highest output channel SAR for each exposure position ≤ 0.8 W/kg other channels SAR tests are not necessary.

<WCDMA>

Plot No.	Band	Mode	Test Position	Ch.	SAR _{1g} (W/kg)
5	WCDMA V	RMC 12.2K	Right Cheek	4182	0.643
6	WCDMA V	RMC 12.2K	Right Tilted	4182	0.355
7	WCDMA V	RMC 12.2K	Left Cheek	4182	0.704
8	WCDMA V	RMC 12.2K	Left Tilted	4182	0.379
13	WCDMA II	RMC 12.2K	Right Cheek	9538	1.090
14	WCDMA II	RMC 12.2K	Right Tilted	9538	0.204
15	WCDMA II	RMC 12.2K	Left Cheek	9538	1.150
16	WCDMA II	RMC 12.2K	Left Tilted	9538	0.218
17	WCDMA II	RMC 12.2K	Right Cheek	9262	1.370
18	WCDMA II	RMC 12.2K	Right Cheek	9400	1.290
19	WCDMA II	RMC 12.2K	Left Cheek	9262	1.240
20	WCDMA II	RMC 12.2K	Left Cheek	9400	1.250

Note: Per KDB 447498, if the highest output channel SAR for each exposure position ≤ 0.8 W/kg other channels SAR tests are not necessary.

<WLAN>

Plot No.	Band	Mode	Test Position	Ch.	SAR _{1g} (W/kg)
64	WLAN 2.4G	802.11b	Right Cheek	1	0.102
65	WLAN 2.4G	802.11b	Right Tilted	1	0.063
66	WLAN 2.4G	802.11b	Left Cheek	1	0.059
67	WLAN 2.4G	802.11b	Left Tilted	1	0.037

Note: Per KDB 248227, if the highest output channel SAR for each exposure position ≤ 0.8 W/kg other channels SAR tests are not necessary.



11.2 Test Records for Hotspot SAR Test

<GSM>

Plot No.	Band	Mode	Test Position	Gap (cm)	Ch.	SAR _{1g} (W/kg)
37	GSM850	GPRS12	Front	1	128	1.050
38	GSM850	GPRS12	Back	1	128	1.280
39	GSM850	GPRS12	Left Side	1	128	0.899
40	GSM850	GPRS12	Right Side	1	128	0.812
41	GSM850	GPRS12	Bottom Side	1	128	0.099
42	GSM850	GPRS12	Front	1	189	1.110
43	GSM850	GPRS12	Front	1	251	1.220
44	GSM850	GPRS12	Back	1	189	1.330
45	GSM850	GPRS12	Back	1	251	1.410
46	GSM850	GPRS12	Left Side	1	189	0.932
47	GSM850	GPRS12	Left Side	1	251	0.988
48	GSM850	GPRS12	Right Side	1	189	0.852
49	GSM850	GPRS12	Right Side	1	251	0.920
21	GSM1900	GPRS12	Front	1	810	0.755
22	GSM1900	GPRS12	Back	1	810	0.895
23	GSM1900	GPRS12	Left Side	1	810	0.206
24	GSM1900	GPRS12	Right Side	1	810	0.179
25	GSM1900	GPRS12	Bottom Side	1	810	0.599
26	GSM1900	GPRS12	Back	1	512	0.998
27	GSM1900	GPRS12	Back	1	661	0.894

Note:

1. Per KDB 941225 D06, for EUT dimension ≥ 9cm*5cm, the test distance is 1cm. SAR must be measured for all surfaces and sides with a transmitting antenna located within 2.5cm from that surface or edge.
2. As in (1), SAR for Front / Back / Bottom Side / Left Side / Right Side is necessary.
3. Per KDB 447498 if the highest output channel SAR for each exposure position ≤ 0.8 W/kg other channels SAR tests are not necessary.

<WCDMA>

Plot No.	Band	Mode	Test Position	Gap (cm)	Ch.	SAR _{1g} (W/kg)
53	WCDMA V	RMC 12.2K	Front	1	4182	0.575
54	WCDMA V	RMC 12.2K	Back	1	4182	0.689
55	WCDMA V	RMC 12.2K	Left Side	1	4182	0.420
56	WCDMA V	RMC 12.2K	Right Side	1	4182	0.390
57	WCDMA V	RMC 12.2K	Bottom Side	1	4182	0.054
31	WCDMA II	RMC 12.2K	Front	1	9538	0.582
32	WCDMA II	RMC 12.2K	Back	1	9538	0.665
33	WCDMA II	RMC 12.2K	Left Side	1	9538	0.178
34	WCDMA II	RMC 12.2K	Right Side	1	9538	0.157
35	WCDMA II	RMC 12.2K	Bottom Side	1	9538	0.479

Note:

1. Per KDB 941225 D06, for EUT dimension $\geq 9\text{cm} \times 5\text{cm}$, the test distance is 1cm. SAR must be measured for all surfaces and sides with a transmitting antenna located within 2.5cm from that surface or edge.
2. As in (1), SAR for Front / Back / Bottom Side / Left Side / Right Side is necessary.
3. Per KDB 447498, if the highest output channel SAR for each exposure position ≤ 0.8 W/kg other channels SAR tests are not necessary.

<WLAN>

Plot No.	Band	Mode	Test Position	Gap (cm)	Ch.	SAR _{1g} (W/kg)
59	WLAN 2.4G	802.11b	Front	1	1	0.028
60	WLAN 2.4G	802.11b	Back	1	1	0.052
61	WLAN 2.4G	802.11b	Left Side	1	1	0.034
62	WLAN 2.4G	802.11b	Top Side	1	1	0.023

Note:

1. Per KDB 941225 D06, for EUT dimension $\geq 9\text{cm} \times 5\text{cm}$, the test distance is 1cm. SAR must be measured for all surfaces and sides with a transmitting antenna located within 2.5cm from that surface or edge.
2. As in (1), SAR for Front / Back / Top Side / Left Side is necessary.
3. Per KDB 248227, if the highest output channel SAR for each exposure position ≤ 0.8 W/kg other channels SAR tests are not necessary.

11.3 Test Records for Body-worn SAR Test

<GSM>

Plot No.	Band	Mode	Test Position	Gap (cm)	Ch.	Headset	SAR _{1g} (W/kg)
37	GSM850	GPRS12	Front	1	128	-	1.05
38	GSM850	GPRS12	Back	1	128	-	1.28
42	GSM850	GPRS12	Front	1	189	-	1.110
43	GSM850	GPRS12	Front	1	251	-	1.220
44	GSM850	GPRS12	Back	1	189	-	1.330
45	GSM850	GPRS12	Back	1	251	-	1.410
50	GSM850	GPRS12	Back	1	251	V	1.110
51	GSM850	GPRS12	Back	1	128	V	1.050
52	GSM850	GPRS12	Back	1	189	V	1.060
21	GSM1900	GPRS12	Front	1	810	-	0.755
22	GSM1900	GPRS12	Back	1	810	-	0.895
26	GSM1900	GPRS12	Back	1	512	-	0.998
27	GSM1900	GPRS12	Back	1	661	-	0.894
28	GSM1900	GPRS12	Back	1	512	V	0.972
29	GSM1900	GPRS12	Back	1	661	V	0.911
30	GSM1900	GPRS12	Back	1	810	V	0.793

Note:

1. Per KDB 447498, if the highest output channel SAR for each exposure position ≤ 0.8 W/kg other channels SAR tests are not necessary.
2. "V" in the earphone column means the earphone is plugged during SAR testing.

<WCDMA>

Plot No.	Band	Mode	Test Position	Gap (cm)	Ch.	Headset	SAR _{1g} (W/kg)
53	WCDMA V	RMC 12.2K	Front	1	4182	-	0.575
54	WCDMA V	RMC 12.2K	Back	1	4182	-	0.689
58	WCDMA V	RMC 12.2K	Back	1	4182	V	0.494
31	WCDMA II	RMC 12.2K	Front	1	9538	-	0.582
32	WCDMA II	RMC 12.2K	Back	1	9538	-	0.665
36	WCDMA II	RMC 12.2K	Back	1	9538	V	0.620

Note:

1. Per KDB 447498, if the highest output channel SAR for each exposure position ≤ 0.8 W/kg other channels SAR tests are not necessary.
2. "V" in the earphone column means the earphone is plugged during SAR testing.

<WLAN>

Plot No.	Band	Mode	Test Position	Gap (cm)	Ch.	Headset	SAR _{1g} (W/kg)
59	WLAN 2.4G	802.11b	Front	1	1	-	0.028
60	WLAN 2.4G	802.11b	Back	1	1	-	0.052
63	WLAN 2.4G	802.11b	Back	1	1	V	0.043

Note:

1. Per KDB 447498, if the highest output channel SAR for each exposure position ≤ 0.8 W/kg other channels SAR tests are not necessary.
2. "V" in the earphone column means the earphone is plugged during SAR testing.

11.4 Simultaneous Multi-band Transmission Analysis

No.	Applicable Simultaneous Transmission Combination
1	GSM + Bluetooth
2	WCDMA + Bluetooth
3	GSM + WLAN 2.4G
4	WCDMA + WLAN 2.4G

Note:

1. WLAN and Bluetooth share the same antenna, and cannot transmit simultaneously.
2. GSM and WCDMA share the same antenna, and cannot transmit simultaneously.
3. Per KDB KDB 648474 D01, Bluetooth (4.24 dBm) output power $\leq 2P_{ref}$ and the distance to WWAN transmitting antenna $\geq 5\text{cm}$, therefore, stand-alone SAR is not required; the simultaneous transmission SAR for WWAN and Bluetooth were not required, because Bluetooth standalone SAR is not required and the maximum WWAN SAR (1.41 W/kg), so the SAR summation is less than 1.6 W/kg.
4. According to KDB 648474, the simultaneous transmission SAR for WWAN and WLAN was not required, because the SAR summation (Head: 1.47 W/kg; Body: 1.46 W/kg) is less than 1.6 W/kg.



<Head SAR>

Position	WWAN						WLAN 2.4G		Max. SAR Summation	Scaled WWAN + WLAN
	WWAN Band	Max. WWAN SAR (W/kg)	Average Power (dBm)	Max. Tolerance Power (dBm)	Scaling Factor	Scaled WWAN (W/kg)	Max. WLAN SAR (W/kg)	Average Power (dBm)		
Right Cheek	GSM850	0.711	32.47	35	1.79	1.273	0.102	14.86	0.81	1.38
	GSM1900	0.701	29.8	32	1.66	1.163	0.102	14.86	0.80	1.27
	WCDMA V	0.643	22.57	25	1.75	1.125	0.102	14.86	0.75	1.23
	WCDMA II	1.37	21.75	22	1.06	1.451	0.102	14.86	1.47	1.55
Right Tilted	GSM850	0.424	32.47	35	1.79	0.759	0.063	14.86	0.49	0.82
	GSM1900	0.151	29.8	32	1.66	0.251	0.063	14.86	0.21	0.31
	WCDMA V	0.355	22.57	25	1.75	0.621	0.063	14.86	0.42	0.68
	WCDMA II	0.204	21.75	22	1.06	0.216	0.063	14.86	0.27	0.28
Left Cheek	GSM850	0.757	32.47	35	1.79	1.355	0.059	14.86	0.82	1.41
	GSM1900	0.776	29.8	32	1.66	1.288	0.059	14.86	0.84	1.35
	WCDMA V	0.704	22.57	25	1.75	1.232	0.059	14.86	0.76	1.29
	WCDMA II	1.25	21.75	22	1.06	1.324	0.059	14.86	1.31	1.38
Left Tilted	GSM850	0.413	32.47	35	1.79	0.740	0.037	14.86	0.45	0.78
	GSM1900	0.115	29.8	32	1.66	0.191	0.037	14.86	0.15	0.23
	WCDMA V	0.379	22.57	25	1.75	0.663	0.037	14.86	0.42	0.70
	WCDMA II	0.218	21.75	22	1.06	0.231	0.037	14.86	0.26	0.27

Note:

1. The maximum SAR summation is calculated based on the same configuration and test position.
2. When stand-alone 1-g SAR is not required for a transmitter or antenna, its SAR is considered zero in the 1-g SAR summing process to determine simultaneous transmission SAR evaluation requirements
3. If 1g-SAR scalar summation < 1.6W/kg, simultaneous SAR measurement is not necessary.



<Hotspot SAR>

Position	WWAN						WLAN 2.4G		Max. SAR Summation	Scaled WWAN + WLAN
	WWAN Band	Max. WWAN SAR (W/kg)	Average Power (dBm)	Max. Tolerance Power (dBm)	Scaling Factor	Scaled WWAN (W/kg)	Max. WLAN SAR (W/kg)	Average Power (dBm)		
Front	GSM850	1.22	28.9	29.2	1.07	1.307	0.028	14.86	1.25	1.34
	GSM1900	0.755	26.33	27	1.17	0.881	0.028	14.86	0.78	0.91
	WCDMA V	0.575	22.57	25	1.75	1.006	0.028	14.86	0.60	1.03
	WCDMA II	0.582	21.8	22	1.05	0.609	0.028	14.86	0.61	0.64
Back	GSM850	1.41	28.9	29.2	1.07	1.511	0.052	14.86	1.46	1.56
	GSM1900	0.998	25.44	27	1.43	1.429	0.052	14.86	1.05	1.48
	WCDMA V	0.689	22.57	25	1.75	1.206	0.052	14.86	0.74	1.26
	WCDMA II	0.665	21.8	22	1.05	0.696	0.052	14.86	0.72	0.75
Left Side	GSM850	0.988	28.9	29.2	1.07	1.059	0.034	14.86	1.02	1.09
	GSM1900	0.206	26.33	27	1.17	0.240	0.034	14.86	0.24	0.27
	WCDMA V	0.42	22.57	25	1.75	0.735	0.034	14.86	0.45	0.77
	WCDMA II	0.178	21.8	22	1.05	0.186	0.034	14.86	0.21	0.22
Right Side	GSM850	0.92	28.9	29.2	1.07	0.986	-	-	0.92	0.99
	GSM1900	0.179	26.33	27	1.17	0.209	-	-	0.18	0.21
	WCDMA V	0.39	22.57	25	1.75	0.682	-	-	0.39	0.68
	WCDMA II	0.157	21.8	22	1.05	0.164	-	-	0.16	0.16
Top Side	GSM850	-	-	-	-	-	0.023	14.86	0.02	0.02
	GSM1900	-	-	-	-	-	0.023	14.86	0.02	0.02
	WCDMA V	-	-	-	-	-	0.023	14.86	0.02	0.02
	WCDMA II	-	-	-	-	-	0.023	14.86	0.02	0.02
Bottom Side	GSM850	0.099	29.16	29.2	1.01	0.100	-	-	0.10	0.10
	GSM1900	0.599	26.33	27	1.17	0.699	-	-	0.60	0.70
	WCDMA V	0.054	22.57	25	1.75	0.094	-	-	0.05	0.09
	WCDMA II	0.479	21.8	22	1.05	0.502	-	-	0.48	0.50

Note:

1. The maximum SAR summation is calculated based on the same configuration and test position.
2. When stand-alone 1-g SAR is not required for a transmitter or antenna, its SAR is considered zero in the 1-g SAR summing process to determine simultaneous transmission SAR evaluation requirements
3. If 1g-SAR scalar summation < 1.6W/kg, simultaneous SAR measurement is not necessary.



<Body-worn SAR>

Position	WWAN						WLAN 2.4G		Max. SAR Summation	Scaled WWAN + WLAN
	WWAN Band	Max. WWAN SAR (W/kg)	Average Power (dBm)	Max. Tolerance Power (dBm)	Scaling Factor	Scaled WWAN (W/kg)	Max. WLAN SAR (W/kg)	Average Power (dBm)		
Back (w/ headset)	GSM850	1.11	28.9	29.2	1.07	1.189	0.043	14.86	1.15	1.23
	GSM1900	0.972	25.44	27	1.43	1.392	0.043	14.86	1.02	1.44
	WCDMA V	0.494	22.57	25	1.75	0.864	0.043	14.86	0.54	0.91
	WCDMA II	0.62	21.8	22	1.05	0.649	0.043	14.86	0.66	0.69

Note:

1. The maximum SAR summation is calculated based on the same configuration and test position.
2. When stand-alone 1-g SAR is not required for a transmitter or antenna, its SAR is considered zero in the 1-g SAR summing process to determine simultaneous transmission SAR evaluation requirements
3. If 1g-SAR scalar summation < 1.6W/kg, simultaneous SAR measurement is not necessary.

Test Engineer : Kat Yin

12. Uncertainty Assessment

The component of uncertainty may generally be categorized according to the methods used to evaluate them. The evaluation of uncertainty by the statistical analysis of a series of observations is termed a Type A evaluation of uncertainty. The evaluation of uncertainty by means other than the statistical analysis of a series of observations is termed a Type B evaluation of uncertainty. Each component of uncertainty, however evaluated, is represented by an estimated standard deviation, termed standard uncertainty, which is determined by the positive square root of the estimated variance.

A Type A evaluation of standard uncertainty may be based on any valid statistical method for treating data. This includes calculating the standard deviation of the mean of a series of independent observations; using the method of least squares to fit a curve to the data in order to estimate the parameter of the curve and their standard deviations; or carrying out an analysis of variance in order to identify and quantify random effects in certain kinds of measurement.

A type B evaluation of standard uncertainty is typically based on scientific judgment using all of the relevant information available. These may include previous measurement data, experience and knowledge of the behavior and properties of relevant materials and instruments, manufacture’s specification, data provided in calibration reports and uncertainties assigned to reference data taken from handbooks. Broadly speaking, the uncertainty is either obtained from an outdoor source or obtained from an assumed distribution, such as the normal distribution, rectangular or triangular distributions indicated in Table 12.1

Uncertainty Distributions	Normal	Rectangular	Triangular	U-Shape
Multi-plying Factor ^(a)	1/k ^(b)	1/√3	1/√6	1/√2

(a) standard uncertainty is determined as the product of the multiplying factor and the estimated range of variations in the measured quantity

(b) κ is the coverage factor

Table 12.1 Standard Uncertainty for Assumed Distribution

The combined standard uncertainty of the measurement result represents the estimated standard deviation of the result. It is obtained by combining the individual standard uncertainties of both Type A and Type B evaluation using the usual “root-sum-squares” (RSS) methods of combining standard deviations by taking the positive square root of the estimated variances.

Expanded uncertainty is a measure of uncertainty that defines an interval about the measurement result within which the measured value is confidently believed to lie. It is obtained by multiplying the combined standard uncertainty by a coverage factor. Typically, the coverage factor ranges from 2 to 3. Using a coverage factor allows the true value of a measured quantity to be specified with a defined probability within the specified uncertainty range. For purpose of this document, a coverage factor two is used, which corresponds to confidence interval of about 95 %. The DASY uncertainty Budget is shown in the following tables.



Error Description	Uncertainty	Probability	Divisor	Ci	Ci	Standard	Standard
	Value (±%)	Distribution		(1g)	(10g)	Uncertainty (1g)	Uncertainty (10g)
Measurement System							
Probe Calibration	6.0	Normal	1	1	1	± 6.0 %	± 6.0 %
Axial Isotropy	4.7	Rectangular	√3	0.7	0.7	± 1.9 %	± 1.9 %
Hemispherical Isotropy	9.6	Rectangular	√3	0.7	0.7	± 3.9 %	± 3.9 %
Boundary Effects	1.0	Rectangular	√3	1	1	± 0.6 %	± 0.6 %
Linearity	4.7	Rectangular	√3	1	1	± 2.7 %	± 2.7 %
System Detection Limits	1.0	Rectangular	√3	1	1	± 0.6 %	± 0.6 %
Readout Electronics	0.3	Normal	1	1	1	± 0.3 %	± 0.3 %
Response Time	0.8	Rectangular	√3	1	1	± 0.5 %	± 0.5 %
Integration Time	2.6	Rectangular	√3	1	1	± 1.5 %	± 1.5 %
RF Ambient Noise	3.0	Rectangular	√3	1	1	± 1.7 %	± 1.7 %
RF Ambient Reflections	3.0	Rectangular	√3	1	1	± 1.7 %	± 1.7 %
Probe Positioner	0.4	Rectangular	√3	1	1	± 0.2 %	± 0.2 %
Probe Positioning	2.9	Rectangular	√3	1	1	± 1.7 %	± 1.7 %
Max. SAR Eval.	1.0	Rectangular	√3	1	1	± 0.6 %	± 0.6 %
Test Sample Related							
Device Positioning	2.9	Normal	1	1	1	± 2.9 %	± 2.9 %
Device Holder	3.6	Normal	1	1	1	± 3.6 %	± 3.6 %
Power Drift	5.0	Rectangular	√3	1	1	± 2.9 %	± 2.9 %
Phantom and Setup							
Phantom Uncertainty	4.0	Rectangular	√3	1	1	± 2.3 %	± 2.3 %
Liquid Conductivity (Target)	5.0	Rectangular	√3	0.64	0.43	± 1.8 %	± 1.2 %
Liquid Conductivity (Meas.)	2.5	Normal	1	0.64	0.43	± 1.6 %	± 1.1 %
Liquid Permittivity (Target)	5.0	Rectangular	√3	0.6	0.49	± 1.7 %	± 1.4 %
Liquid Permittivity (Meas.)	2.5	Normal	1	0.6	0.49	± 1.5 %	± 1.2 %
Combined Standard Uncertainty						± 11.0 %	± 10.8 %
Coverage Factor for 95 %						K=2	
Expanded Uncertainty						± 22.0 %	± 21.5 %

Table 12.2 Uncertainty Budget of DASY for frequency range 300 MHz to 3 GHz

13. References

- [1] FCC 47 CFR Part 2 "Frequency Allocations and Radio Treaty Matters; General Rules and Regulations"
- [2] ANSI/IEEE Std. C95.1-1992, "IEEE Standard for Safety Levels with Respect to Human Exposure to Radio Frequency Electromagnetic Fields, 3 kHz to 300 GHz", September 1992
- [3] IEEE Std. 1528-2003, "Recommended Practice for Determining the Peak Spatial-Average Specific Absorption Rate (SAR) in the Human Head from Wireless Communications Devices: Measurement Techniques", December 2003
- [4] FCC OET Bulletin 65 (Edition 97-01) Supplement C (Edition 01-01), "Evaluating Compliance with FCC Guidelines for Human Exposure to Radiofrequency Electromagnetic Fields", June 2001
- [5] SPEAG DASY System Handbook
- [6] FCC KDB 248227 D01 v01r02, "SAR Measurement Procedures for 802.11 a/b/g Transmitters", May 2007
- [7] FCC KDB 447498 D01 v04, "Mobile and Portable Device RF Exposure Procedures and Equipment Authorization Policies", November 2009
- [8] FCC KDB 648474 D01 v01r05, "SAR Evaluation Considerations for Handsets with Multiple Transmitters and Antennas", September 2008
- [9] FCC KDB 941225 D01 v02, "SAR Measurement Procedures for 3G Devices – CDMA 2000 / Ev-Do / WCDMA / HSDPA / HSPA", October 2007
- [10] FCC KDB 941225 D02 v02 "3GPP R6 HSPA and R7 HSPA+ SAR Guidance", December 2009.
- [11] FCC KDB 941225 D03 v01, "Recommended SAR Test Reduction Procedures for GSM / GPRS / EDGE", December 2008
- [12] FCC KDB 941225 D04 v01, "Evaluating SAR for GSM/(E)GPRS Dual Transfer Mode", January 27 2010
- [13] FCC KDB 941225 D06 v01, "SAR Evaluation Procedures for Portable Devices with Wireless Router Capabilities", April 2011
- [14] FCC KDB 388624 D02, "Permit But Ask List", December 2011.



Appendix A. Plots of System Performance Check

The plots are shown as follows.

System Check_Head_835MHz_120518

DUT: D835V2 - SN: 4d091

Communication System: CW; Frequency: 835 MHz; Duty Cycle: 1:1

Medium: HSL_835_120518 Medium parameters used: $f = 835 \text{ MHz}$; $\sigma = 0.928 \text{ mho/m}$; $\epsilon_r = 42.73$; $\rho = 1000 \text{ kg/m}^3$

Ambient Temperature : 23.7 °C ; Liquid Temperature : 21.7 °C

DASY5 Configuration:

- Probe: ES3DV3 - SN3270; ConvF(6.04, 6.04, 6.04); Calibrated: 12.09.2011
- Sensor-Surface: 4mm (Mechanical Surface Detection)
- Electronics: DAE4 Sn1303; Calibrated: 10.11.2011
- Phantom: SAM2; Type: QD000P40CD; Serial: TP:1671
- Measurement SW: DASY52, Version 52.8 (0); SEMCAD X Version 14.6.4 (4989)

Pin=250mW/Area Scan (61x61x1): Measurement grid: dx=15mm, dy=15mm

Maximum value of SAR (interpolated) = 2.664 mW/g

Pin=250mW/Zoom Scan (7x7x7)/Cube 0: Measurement grid: dx=5mm, dy=5mm, dz=5mm

Reference Value = 53.938 V/m; Power Drift = 0.02 dB

Peak SAR (extrapolated) = 3.7650

SAR(1 g) = 2.48 mW/g; SAR(10 g) = 1.61 mW/g

Maximum value of SAR (measured) = 2.665 mW/g

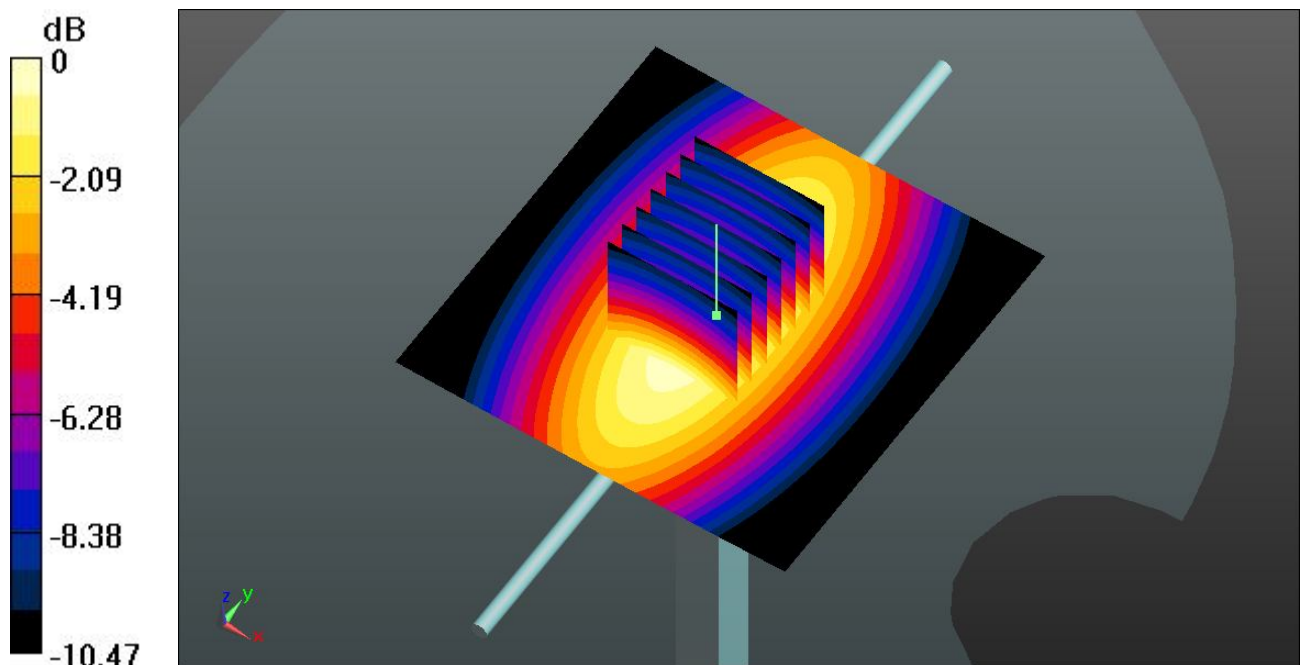

0 dB = 2.660mW/g = 8.50 dB mW/g

System Check_Body_835MHz_120806

DUT: D835V2 - SN: 4d091

Communication System: CW; Frequency: 835 MHz; Duty Cycle: 1:1

Medium: MSL_835_120806 Medium parameters used: $f = 835 \text{ MHz}$; $\sigma = 0.977 \text{ mho/m}$; $\epsilon_r = 54.388$;

$\rho = 1000 \text{ kg/m}^3$

Ambient Temperature : $23.7 \text{ }^\circ\text{C}$; Liquid Temperature : $21.4 \text{ }^\circ\text{C}$

DASY5 Configuration:

- Probe: ES3DV3 - SN3270; ConvF(6.16, 6.16, 6.16); Calibrated: 12.09.2011;
- Sensor-Surface: 4mm (Mechanical Surface Detection)
- Electronics: DAE4 Sn1303; Calibrated: 10.11.2011
- Phantom: SAM1; Type: QD000P40CD; Serial: TP:1670
- Measurement SW: DASY52, Version 52.8 (1); SEMCAD X Version 14.6.5 (6469)

Pin=250mW/Area Scan (61x61x1): Measurement grid: $dx=15\text{mm}$, $dy=15\text{mm}$

Maximum value of SAR (interpolated) = 2.56 mW/g

Pin=250mW/Zoom Scan (7x7x7)/Cube 0: Measurement grid: $dx=5\text{mm}$, $dy=5\text{mm}$, $dz=5\text{mm}$

Reference Value = 51.563 V/m ; Power Drift = -0.02 dB

Peak SAR (extrapolated) = 3.555 mW/g

SAR(1 g) = 2.36 mW/g ; SAR(10 g) = 1.54 mW/g

Maximum value of SAR (measured) = 2.54 mW/g

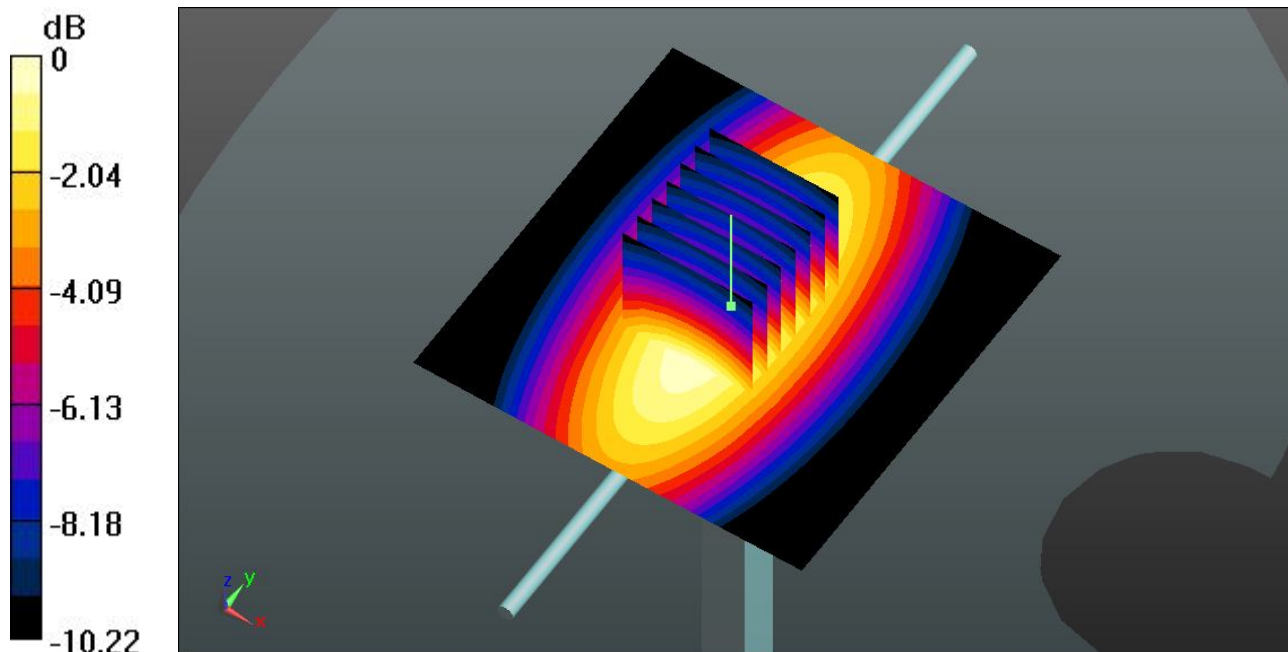

0 dB = 2.54 mW/g = 8.10 dB mW/g

System Check_Head_1900MHz_120518

DUT: D1900V2 - SN: 5d118

Communication System: CW; Frequency: 1900 MHz; Duty Cycle: 1:1

Medium: HSL_1900_120518 Medium parameters used: $f = 1900$ MHz; $\sigma = 1.419$ mho/m; $\epsilon_r =$

40.609; $\rho = 1000$ kg/m³

Ambient Temperature : 23.5 °C; Liquid Temperature : 21.5 °C

DASY5 Configuration:

- Probe: ES3DV3 - SN3270; ConvF(5.14, 5.14, 5.14); Calibrated: 12.09.2011
- Sensor-Surface: 4mm (Mechanical Surface Detection)
- Electronics: DAE4 Sn1303; Calibrated: 10.11.2011
- Phantom: SAM1; Type: QD000P40CD; Serial: TP:1670
- Measurement SW: DASY52, Version 52.8 (0); SEMCAD X Version 14.6.4 (4989)

Pin=250mW/Area Scan (91x91x1): Measurement grid: dx=10mm, dy=10mm

Maximum value of SAR (interpolated) = 11.665 mW/g

Pin=250mW/Zoom Scan (7x7x7)/Cube 0: Measurement grid: dx=5mm, dy=5mm, dz=5mm

Reference Value = 90.479 V/m; Power Drift = -0.13 dB

Peak SAR (extrapolated) = 19.6470

SAR(1 g) = 10.3 mW/g; SAR(10 g) = 5.29 mW/g

Maximum value of SAR (measured) = 11.711 mW/g

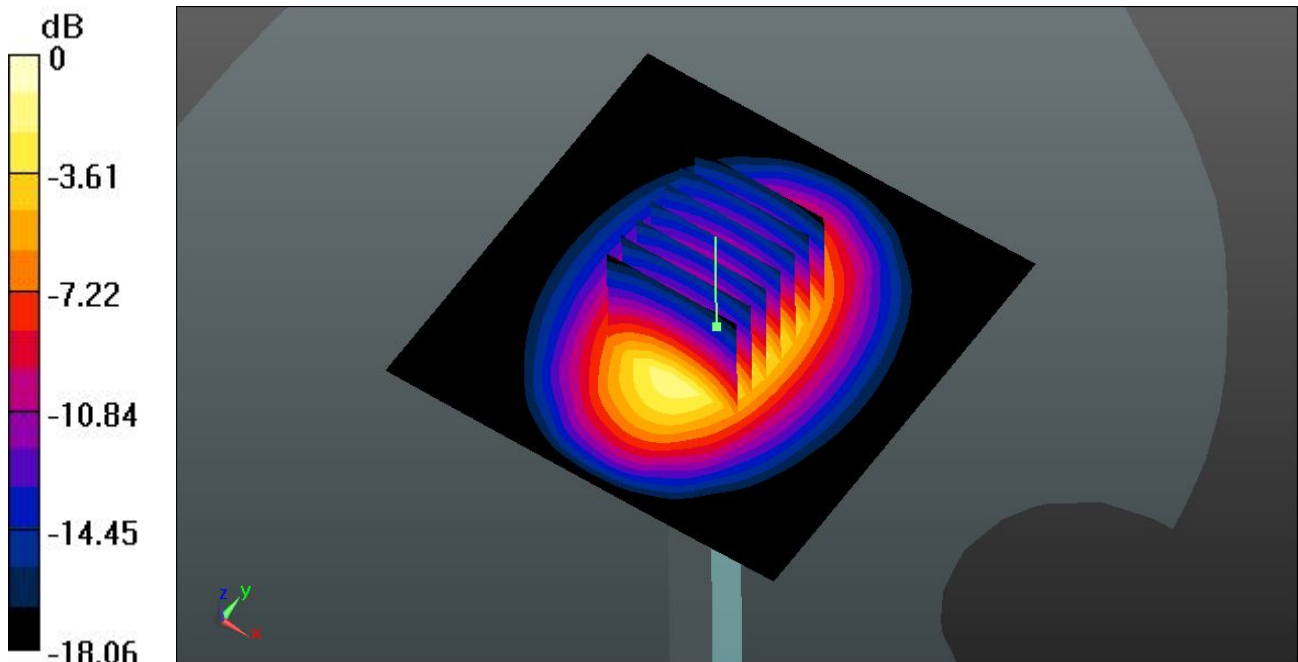

0 dB = 11.710mW/g = 21.37 dB mW/g

System Check_Head_1900MHz_120525

DUT: D1900V2 - SN: 5d118

Communication System: CW; Frequency: 1900 MHz; Duty Cycle: 1:1

Medium: HSL_1900_120525 Medium parameters used: $f = 1900$ MHz; $\sigma = 1.415$ mho/m; $\epsilon_r = 40.527$; $\rho = 1000$ kg/m³

Ambient Temperature : 23.4 °C; Liquid Temperature : 21.5 °C

DASY5 Configuration:

- Probe: ES3DV3 - SN3270; ConvF(5.14, 5.14, 5.14); Calibrated: 12.09.2011;
- Sensor-Surface: 4mm (Mechanical Surface Detection)
- Electronics: DAE4 Sn1303; Calibrated: 10.11.2011
- Phantom: SAM2; Type: QD000P40CD; Serial: TP:1671
- Measurement SW: DASY52, Version 52.8 (1); SEMCAD X Version 14.6.5 (6469)

Pin=250mW/Area Scan (61x61x1): Measurement grid: dx=15mm, dy=15mm

Maximum value of SAR (interpolated) = 11.2 mW/g

Pin=250mW/Zoom Scan (7x7x7)/Cube 0: Measurement grid: dx=5mm, dy=5mm, dz=5mm

Reference Value = 86.420 V/m; Power Drift = 0.01 dB

Peak SAR (extrapolated) = 17.883 mW/g

SAR(1 g) = 9.71 mW/g; SAR(10 g) = 5.07 mW/g

Maximum value of SAR (measured) = 10.9 mW/g

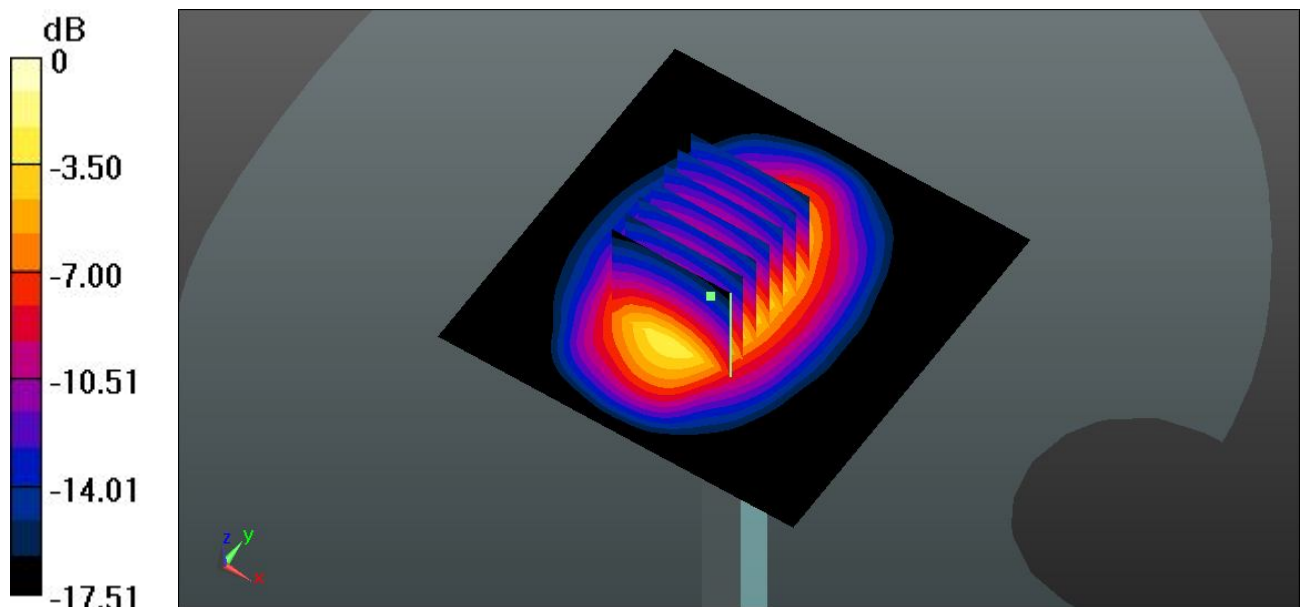

0 dB = 10.9 mW/g = 20.75 dB mW/g

System Check_Body_1900MHz_120806

DUT: D1900V2 - SN: 5d118

Communication System: CW; Frequency: 1900 MHz; Duty Cycle: 1:1

Medium: MSL_1900_120806 Medium parameters used: $f = 1900 \text{ MHz}$; $\sigma = 1.519 \text{ mho/m}$; $\epsilon_r =$

53.569 ; $\rho = 1000 \text{ kg/m}^3$

Ambient Temperature : $23.5 \text{ }^\circ\text{C}$; Liquid Temperature : $21.5 \text{ }^\circ\text{C}$

DASY5 Configuration:

- Probe: ES3DV3 - SN3270; ConvF(4.64, 4.64, 4.64); Calibrated: 12.09.2011;
- Sensor-Surface: 4mm (Mechanical Surface Detection)
- Electronics: DAE4 Sn1303; Calibrated: 10.11.2011
- Phantom: SAM2; Type: QD000P40CD; Serial: TP:1671
- Measurement SW: DASY52, Version 52.8 (1); SEMCAD X Version 14.6.5 (6469)

Pin=250mW/Area Scan (61x61x1): Measurement grid: $dx=15\text{mm}$, $dy=15\text{mm}$

Maximum value of SAR (interpolated) = 12.4 mW/g

Pin=250mW/Zoom Scan (7x7x7)/Cube 0: Measurement grid: $dx=5\text{mm}$, $dy=5\text{mm}$, $dz=5\text{mm}$

Reference Value = 88.882 V/m ; Power Drift = 0.01 dB

Peak SAR (extrapolated) = 19.317 mW/g

SAR(1 g) = 10.6 mW/g ; SAR(10 g) = 5.5 mW/g

Maximum value of SAR (measured) = 11.9 mW/g

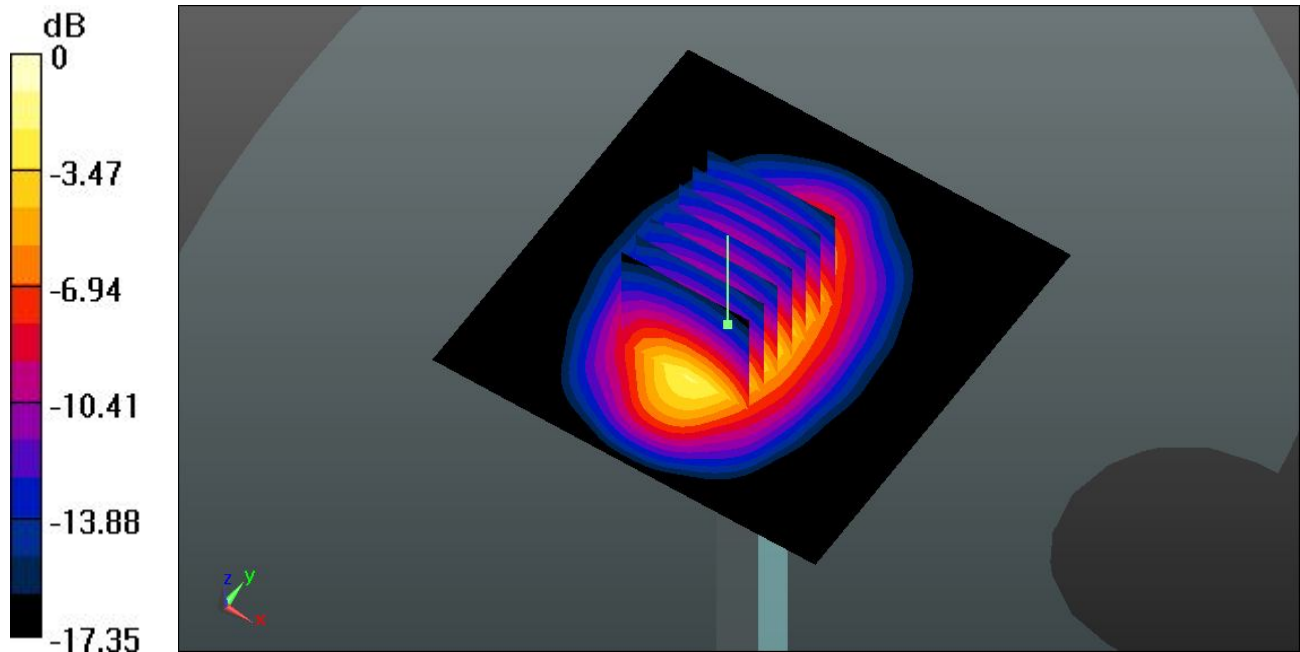

0 dB = 11.9 mW/g = 21.51 dB mW/g

System Check_Head_2450MHz_120723

DUT: D2450V2 - SN: 736

Communication System: CW; Frequency: 2450 MHz; Duty Cycle: 1:1

Medium: HSL_2450_120723 Medium parameters used: $f = 2450$ MHz; $\sigma = 1.834$ mho/m; $\epsilon_r =$

39.654 ; $\rho = 1000$ kg/m³

Ambient Temperature : 23.3 °C ; Liquid Temperature : 21.3 °C

DASY5 Configuration:

- Probe: ES3DV3 - SN3270; ConvF(4.52, 4.52, 4.52); Calibrated: 12.09.2011;
- Sensor-Surface: 4mm (Mechanical Surface Detection)
- Electronics: DAE4 Sn1303; Calibrated: 10.11.2011
- Phantom: SAM1; Type: QD000P40CD; Serial: TP:1670
- Measurement SW: DASY52, Version 52.8 (1); SEMCAD X Version 14.6.5 (6469)

Pin=250mW/Area Scan (61x61x1): Measurement grid: dx=15mm, dy=15mm

Maximum value of SAR (interpolated) = 15.2 mW/g

Pin=250mW/Zoom Scan (7x7x7)/Cube 0: Measurement grid: dx=5mm, dy=5mm, dz=5mm

Reference Value = 89.443 V/m; Power Drift = 0.15 dB

Peak SAR (extrapolated) = 29.326 mW/g

SAR(1 g) = 13.3 mW/g; SAR(10 g) = 5.95 mW/g

Maximum value of SAR (measured) = 15.1 mW/g

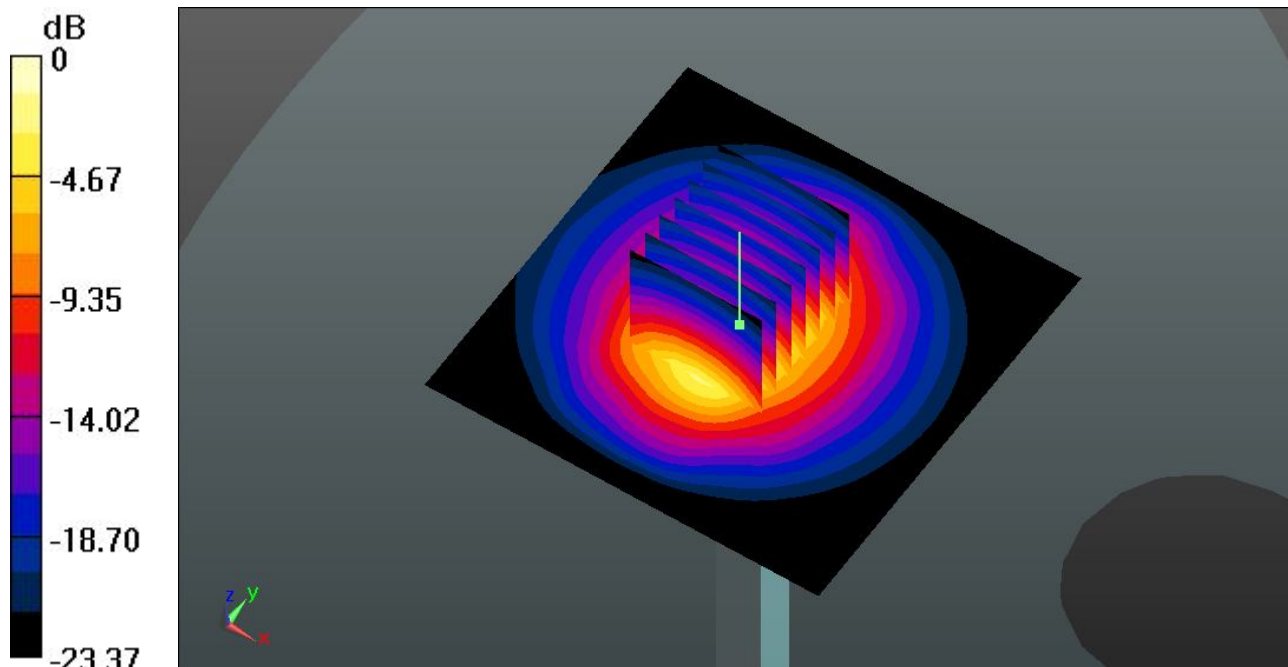

0 dB = 15.1 mW/g = 23.58 dB mW/g

System Check_Body_2450MHz_120807

DUT: D2450V2 - SN: 736

Communication System: CW; Frequency: 2450 MHz; Duty Cycle: 1:1

Medium: MSL_2450_120807 Medium parameters used: $f = 2450$ MHz; $\sigma = 1.951$ mho/m; $\epsilon_r =$

53.859 ; $\rho = 1000$ kg/m³

Ambient Temperature : 23.5 °C ; Liquid Temperature : 21.6 °C

DASY5 Configuration:

- Probe: ES3DV3 - SN3270; ConvF(4.28, 4.28, 4.28); Calibrated: 12.09.2011;
- Sensor-Surface: 4mm (Mechanical Surface Detection)
- Electronics: DAE4 Sn1303; Calibrated: 10.11.2011
- Phantom: SAM2; Type: QD000P40CD; Serial: TP:1671
- Measurement SW: DASY52, Version 52.8 (1); SEMCAD X Version 14.6.5 (6469)

Pin=250mW/Area Scan (61x61x1): Measurement grid: dx=15mm, dy=15mm

Maximum value of SAR (interpolated) = 14.8 mW/g

Pin=250mW/Zoom Scan (7x7x7)/Cube 0: Measurement grid: dx=5mm, dy=5mm, dz=5mm

Reference Value = 87.329 V/m; Power Drift = -0.10 dB

Peak SAR (extrapolated) = 27.931 mW/g

SAR(1 g) = 12.9 mW/g; SAR(10 g) = 5.87 mW/g

Maximum value of SAR (measured) = 14.8 mW/g

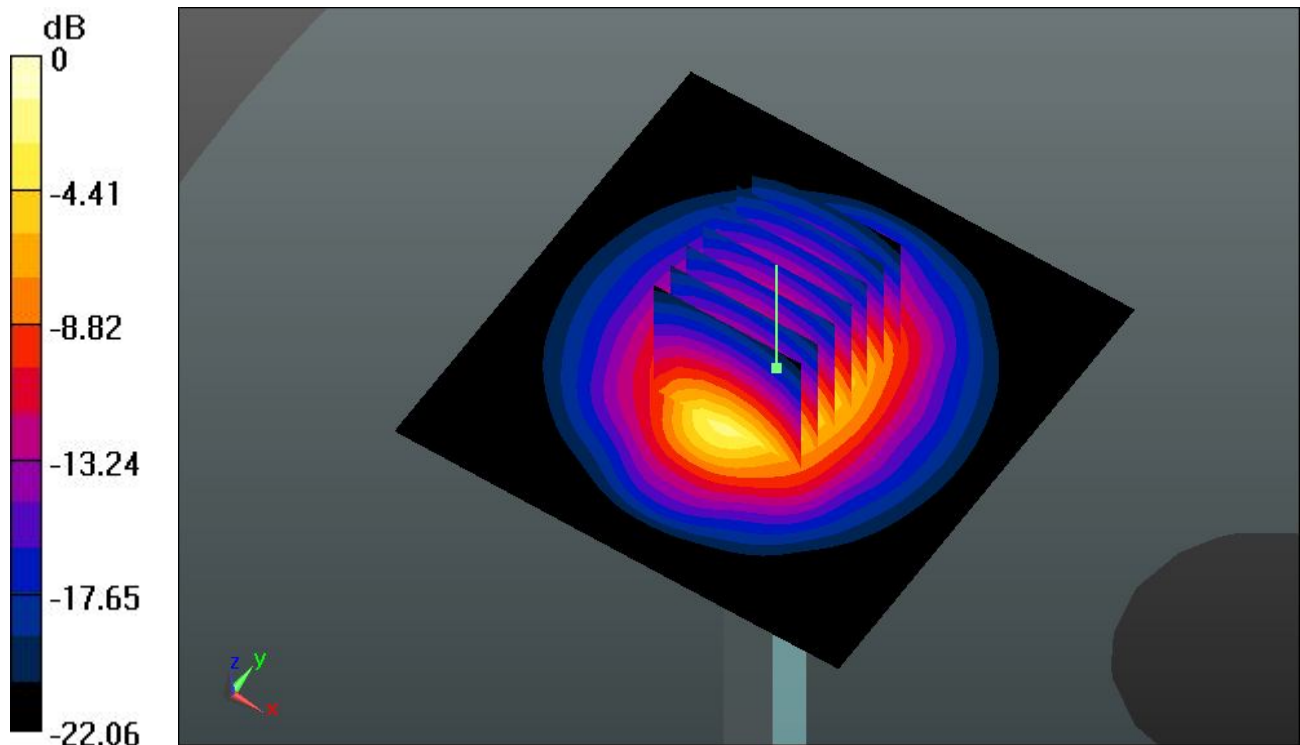

0 dB = 14.8 mW/g = 23.41 dB mW/g



Appendix B. Plots of SAR Measurement

The plots are shown as follows.

01 GSM850_Right Cheek_Ch128

DUT: 251703

Communication System: Generic GSM; Frequency: 824.2 MHz; Duty Cycle: 1:8.3

Medium: HSL_835_120518 Medium parameters used: $f = 824.2$ MHz; $\sigma = 0.917$ mho/m; $\epsilon_r = 42.87$;

$\rho = 1000$ kg/m³

Ambient Temperature : 23.7 °C; Liquid Temperature : 21.7 °C

DASY5 Configuration:

- Probe: ES3DV3 - SN3270; ConvF(6.04, 6.04, 6.04); Calibrated: 12.09.2011
- Sensor-Surface: 4mm (Mechanical Surface Detection)
- Electronics: DAE4 Sn1303; Calibrated: 10.11.2011
- Phantom: SAM2; Type: QD000P40CD; Serial: TP:1671
- Measurement SW: DASY52, Version 52.8 (0); SEMCAD X Version 14.6.4 (4989)

Ch128/Area Scan (61x91x1): Measurement grid: dx=15mm, dy=15mm

Maximum value of SAR (interpolated) = 0.739 mW/g

Ch128/Zoom Scan (5x5x7)/Cube 0: Measurement grid: dx=8mm, dy=8mm, dz=5mm

Reference Value = 10.317 V/m; Power Drift = -0.04 dB

Peak SAR (extrapolated) = 0.9700

SAR(1 g) = 0.711 mW/g; SAR(10 g) = 0.506 mW/g

Maximum value of SAR (measured) = 0.769 mW/g

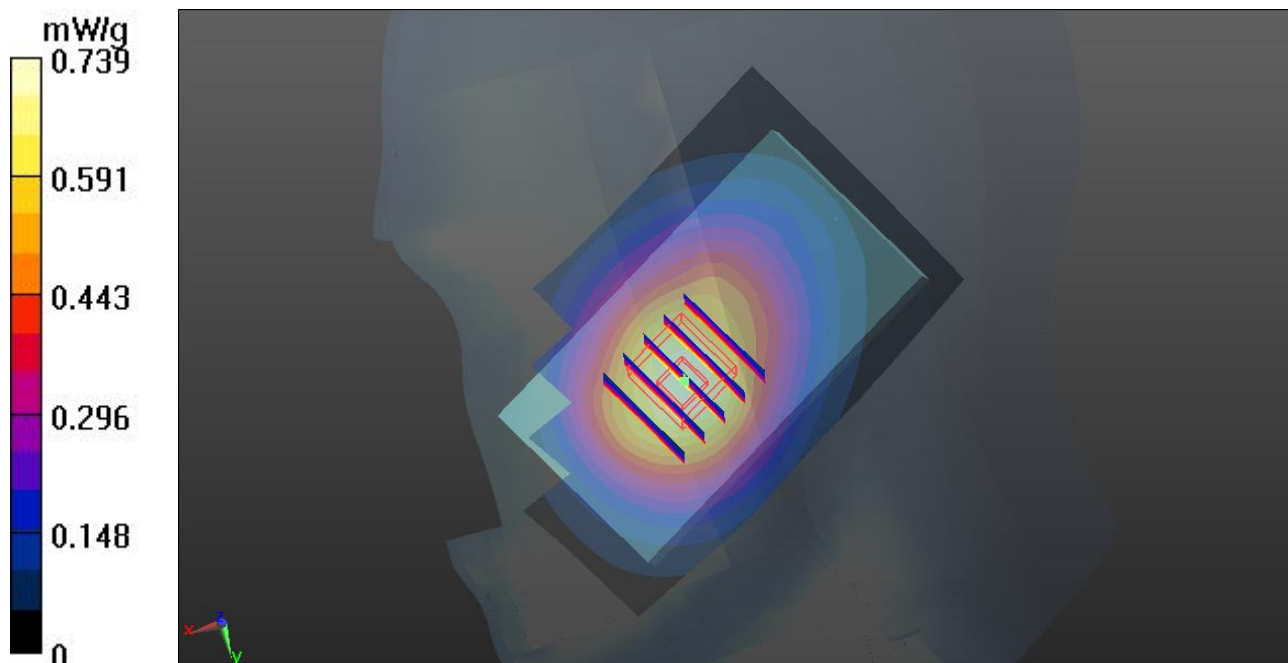

02 GSM850_Right Tilted_Ch128

DUT: 251703

Communication System: Generic GSM; Frequency: 824.2 MHz; Duty Cycle: 1:8.3

Medium: HSL_835_120518 Medium parameters used: $f = 824.2$ MHz; $\sigma = 0.917$ mho/m; $\epsilon_r = 42.87$;

$\rho = 1000$ kg/m³

Ambient Temperature : 23.7 °C; Liquid Temperature : 21.7 °C

DASY5 Configuration:

- Probe: ES3DV3 - SN3270; ConvF(6.04, 6.04, 6.04); Calibrated: 12.09.2011
- Sensor-Surface: 4mm (Mechanical Surface Detection)
- Electronics: DAE4 Sn1303; Calibrated: 10.11.2011
- Phantom: SAM2; Type: QD000P40CD; Serial: TP:1671
- Measurement SW: DASY52, Version 52.8 (0); SEMCAD X Version 14.6.4 (4989)

Ch128/Area Scan (61x91x1): Measurement grid: dx=15mm, dy=15mm

Maximum value of SAR (interpolated) = 0.447 mW/g

Ch128/Zoom Scan (5x5x7)/Cube 0: Measurement grid: dx=8mm, dy=8mm, dz=5mm

Reference Value = 15.364 V/m; Power Drift = -0.02 dB

Peak SAR (extrapolated) = 0.5490

SAR(1 g) = 0.424 mW/g; SAR(10 g) = 0.316 mW/g

Maximum value of SAR (measured) = 0.448 mW/g

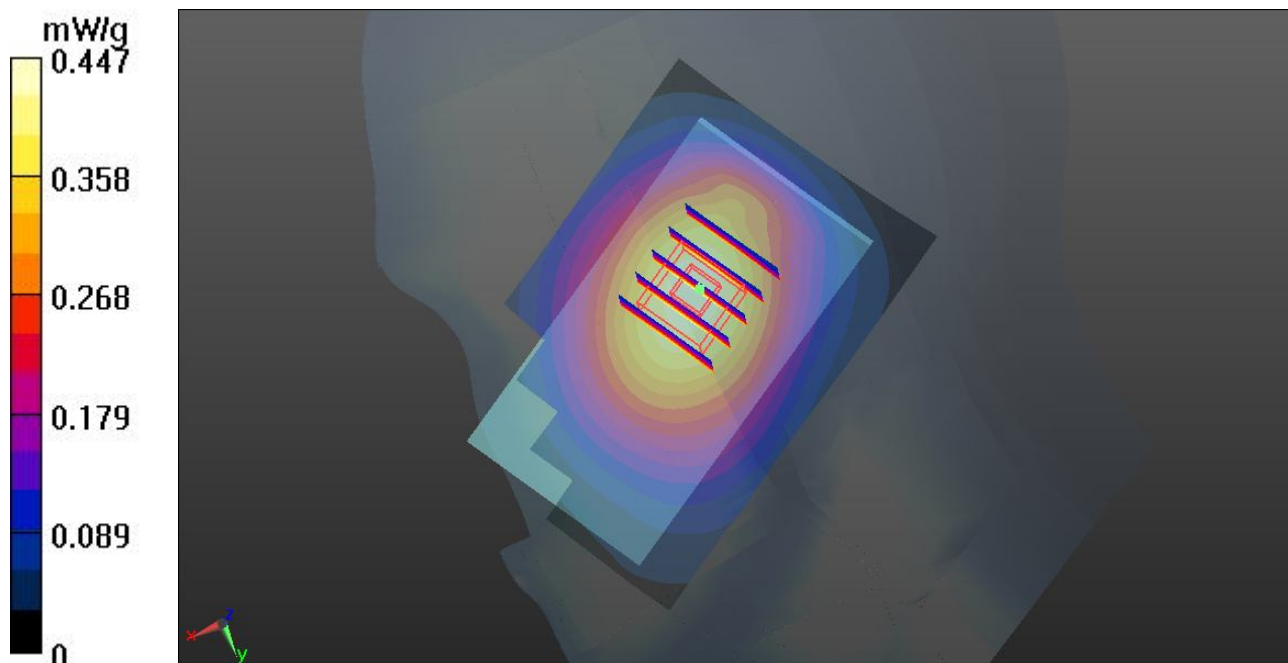

03 GSM850_Left Cheek_Ch128

DUT: 251703

Communication System: Generic GSM; Frequency: 824.2 MHz; Duty Cycle: 1:8.3

Medium: HSL_835_120518 Medium parameters used: $f = 824.2$ MHz; $\sigma = 0.917$ mho/m; $\epsilon_r = 42.87$;

$\rho = 1000$ kg/m³

Ambient Temperature : 23.7 °C; Liquid Temperature : 21.7 °C

DASY5 Configuration:

- Probe: ES3DV3 - SN3270; ConvF(6.04, 6.04, 6.04); Calibrated: 12.09.2011
- Sensor-Surface: 4mm (Mechanical Surface Detection)
- Electronics: DAE4 Sn1303; Calibrated: 10.11.2011
- Phantom: SAM2; Type: QD000P40CD; Serial: TP:1671
- Measurement SW: DASY52, Version 52.8 (0); SEMCAD X Version 14.6.4 (4989)

Ch128/Area Scan (61x91x1): Measurement grid: dx=15mm, dy=15mm

Maximum value of SAR (interpolated) = 0.785 mW/g

Ch128/Zoom Scan (5x5x7)/Cube 0: Measurement grid: dx=8mm, dy=8mm, dz=5mm

Reference Value = 9.375 V/m; Power Drift = -0.10 dB

Peak SAR (extrapolated) = 0.9890

SAR(1 g) = 0.757 mW/g; SAR(10 g) = 0.545 mW/g

Maximum value of SAR (measured) = 0.801 mW/g

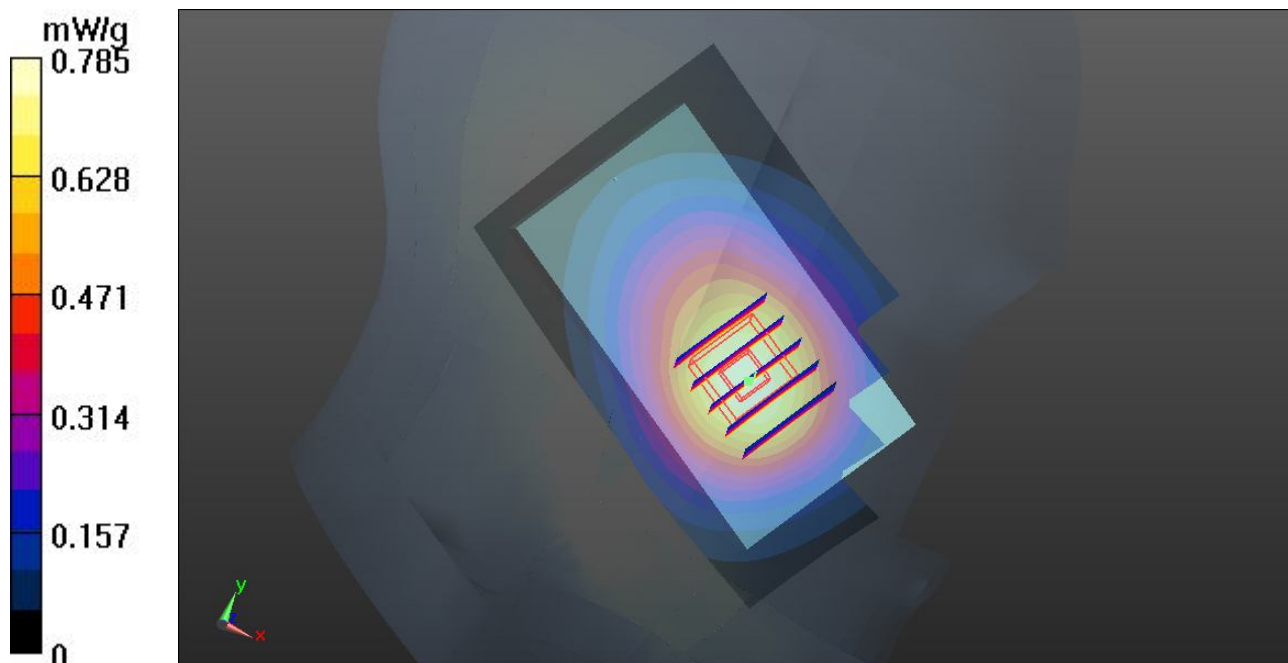

03 GSM850_Left Cheek_Ch128_2D

DUT: 251703

Communication System: Generic GSM; Frequency: 824.2 MHz; Duty Cycle: 1:8.3

Medium: HSL_835_120518 Medium parameters used: $f = 824.2$ MHz; $\sigma = 0.917$ mho/m; $\epsilon_r = 42.87$;

$\rho = 1000$ kg/m³

Ambient Temperature : 23.7 °C ; Liquid Temperature : 21.7 °C

DASY5 Configuration:

- Probe: ES3DV3 - SN3270; ConvF(6.04, 6.04, 6.04); Calibrated: 12.09.2011
- Sensor-Surface: 4mm (Mechanical Surface Detection)
- Electronics: DAE4 Sn1303; Calibrated: 10.11.2011
- Phantom: SAM2; Type: QD000P40CD; Serial: TP:1671
- Measurement SW: DASY52, Version 52.8 (0); SEMCAD X Version 14.6.4 (4989)

Ch128/Area Scan (61x91x1): Measurement grid: dx=15mm, dy=15mm

Maximum value of SAR (interpolated) = 0.785 mW/g

Ch128/Zoom Scan (5x5x7)/Cube 0: Measurement grid: dx=8mm, dy=8mm, dz=5mm

Reference Value = 9.375 V/m; Power Drift = -0.10 dB

Peak SAR (extrapolated) = 0.9890

SAR(1 g) = 0.757 mW/g; SAR(10 g) = 0.545 mW/g

Maximum value of SAR (measured) = 0.801 mW/g

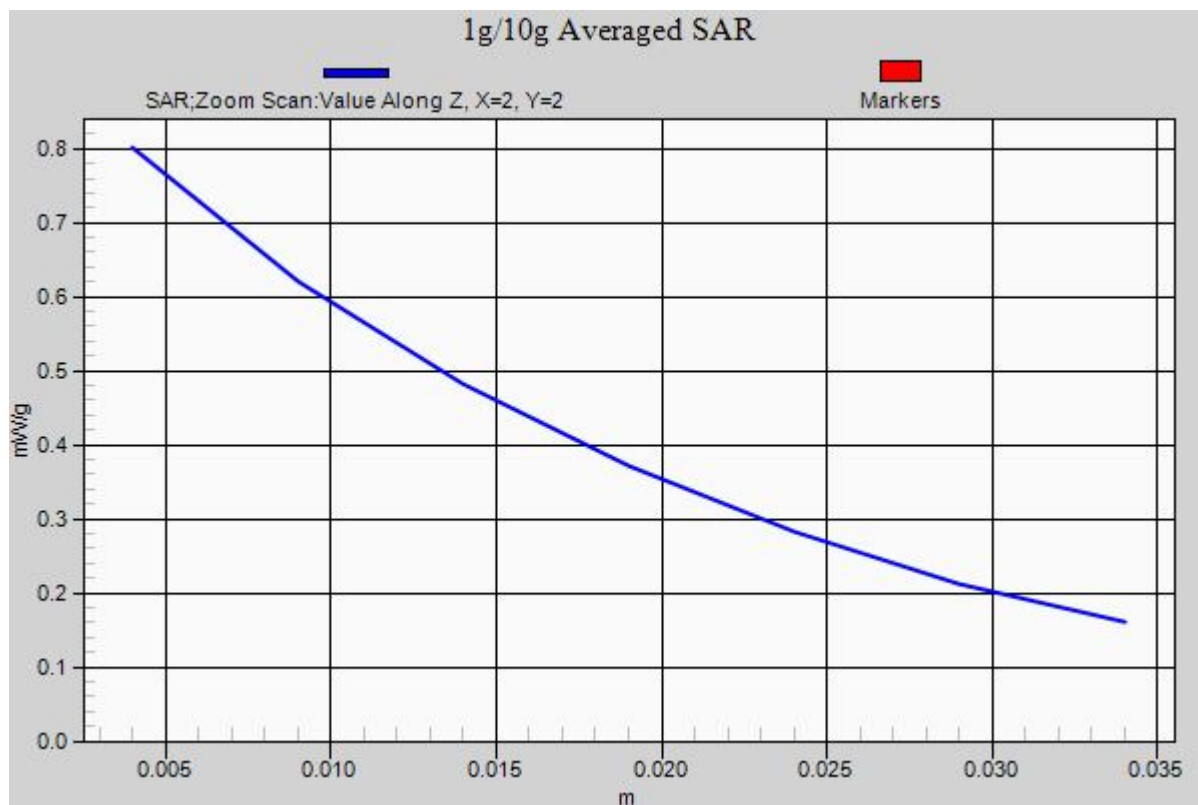

04 GSM850_Left Tilted_Ch128

DUT: 251703

Communication System: Generic GSM; Frequency: 824.2 MHz; Duty Cycle: 1:8.3

Medium: HSL_835_120518 Medium parameters used: $f = 824.2$ MHz; $\sigma = 0.917$ mho/m; $\epsilon_r = 42.87$;

$\rho = 1000$ kg/m³

Ambient Temperature : 23.7 °C; Liquid Temperature : 21.7 °C

DASY5 Configuration:

- Probe: ES3DV3 - SN3270; ConvF(6.04, 6.04, 6.04); Calibrated: 12.09.2011
- Sensor-Surface: 4mm (Mechanical Surface Detection)
- Electronics: DAE4 Sn1303; Calibrated: 10.11.2011
- Phantom: SAM2; Type: QD000P40CD; Serial: TP:1671
- Measurement SW: DASY52, Version 52.8 (0); SEMCAD X Version 14.6.4 (4989)

Ch128/Area Scan (61x91x1): Measurement grid: dx=15mm, dy=15mm

Maximum value of SAR (interpolated) = 0.426 mW/g

Ch128/Zoom Scan (5x5x7)/Cube 0: Measurement grid: dx=8mm, dy=8mm, dz=5mm

Reference Value = 14.514 V/m; Power Drift = -0.03 dB

Peak SAR (extrapolated) = 0.5350

SAR(1 g) = 0.413 mW/g; SAR(10 g) = 0.308 mW/g

Maximum value of SAR (measured) = 0.432 mW/g

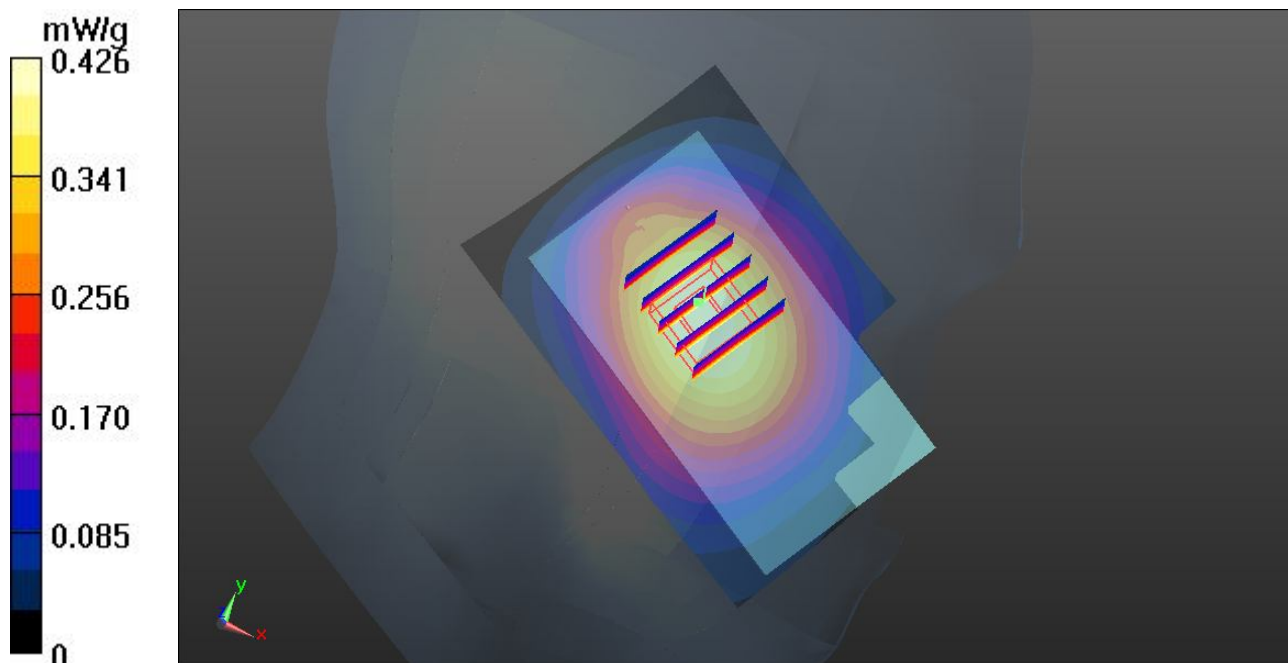

09 GSM1900_Right Cheek_Ch810

DUT: 251703

Communication System: Generic GSM; Frequency: 1909.8 MHz; Duty Cycle: 1:8.3

Medium: HSL_1900_120518 Medium parameters used: $f = 1910$ MHz; $\sigma = 1.43$ mho/m; $\epsilon_r = 40.64$; $\rho = 1000$ kg/m³

Ambient Temperature : 23.5 °C ; Liquid Temperature : 21.5 °C

DASY5 Configuration:

- Probe: ES3DV3 - SN3270; ConvF(5.14, 5.14, 5.14); Calibrated: 12.09.2011
- Sensor-Surface: 4mm (Mechanical Surface Detection)
- Electronics: DAE4 Sn1303; Calibrated: 10.11.2011
- Phantom: SAM1; Type: QD000P40CD; Serial: TP:1670
- Measurement SW: DASY52, Version 52.8 (0); SEMCAD X Version 14.6.4 (4989)

Ch810/Area Scan (61x91x1): Measurement grid: dx=15mm, dy=15mm

Maximum value of SAR (interpolated) = 0.780 mW/g

Ch810/Zoom Scan (5x5x7)/Cube 0: Measurement grid: dx=8mm, dy=8mm, dz=5mm

Reference Value = 8.028 V/m; Power Drift = -0.09 dB

Peak SAR (extrapolated) = 1.0800

SAR(1 g) = 0.701 mW/g; SAR(10 g) = 0.414 mW/g

Maximum value of SAR (measured) = 0.760 mW/g

Ch810/Zoom Scan (5x5x7)/Cube 1: Measurement grid: dx=8mm, dy=8mm, dz=5mm

Reference Value = 8.028 V/m; Power Drift = -0.09 dB

Peak SAR (extrapolated) = 0.8880

SAR(1 g) = 0.573 mW/g; SAR(10 g) = 0.345 mW/g

Maximum value of SAR (measured) = 0.700 mW/g

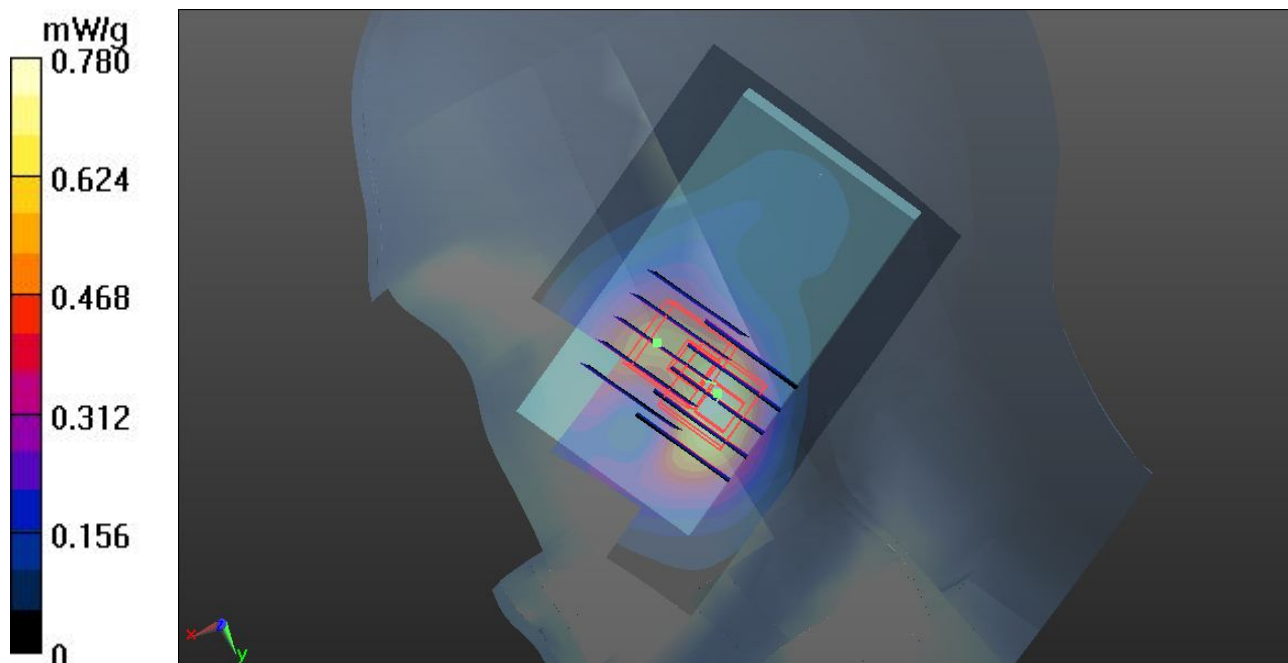

10 GSM1900_Right Tilted_Ch810

DUT: 251703

Communication System: Generic GSM; Frequency: 1909.8 MHz; Duty Cycle: 1:8.3

Medium: HSL_1900_120518 Medium parameters used: $f = 1910$ MHz; $\sigma = 1.43$ mho/m; $\epsilon_r = 40.64$; $\rho = 1000$ kg/m³

Ambient Temperature : 23.5 °C; Liquid Temperature : 21.5 °C

DASY5 Configuration:

- Probe: ES3DV3 - SN3270; ConvF(5.14, 5.14, 5.14); Calibrated: 12.09.2011
- Sensor-Surface: 4mm (Mechanical Surface Detection)
- Electronics: DAE4 Sn1303; Calibrated: 10.11.2011
- Phantom: SAM1; Type: QD000P40CD; Serial: TP:1670
- Measurement SW: DASY52, Version 52.8 (0); SEMCAD X Version 14.6.4 (4989)

Ch810/Area Scan (61x91x1): Measurement grid: dx=15mm, dy=15mm

Maximum value of SAR (interpolated) = 0.178 mW/g

Ch810/Zoom Scan (5x5x7)/Cube 0: Measurement grid: dx=8mm, dy=8mm, dz=5mm

Reference Value = 10.949 V/m; Power Drift = 0.01 dB

Peak SAR (extrapolated) = 0.2450

SAR(1 g) = 0.151 mW/g; SAR(10 g) = 0.088 mW/g

Maximum value of SAR (measured) = 0.162 mW/g

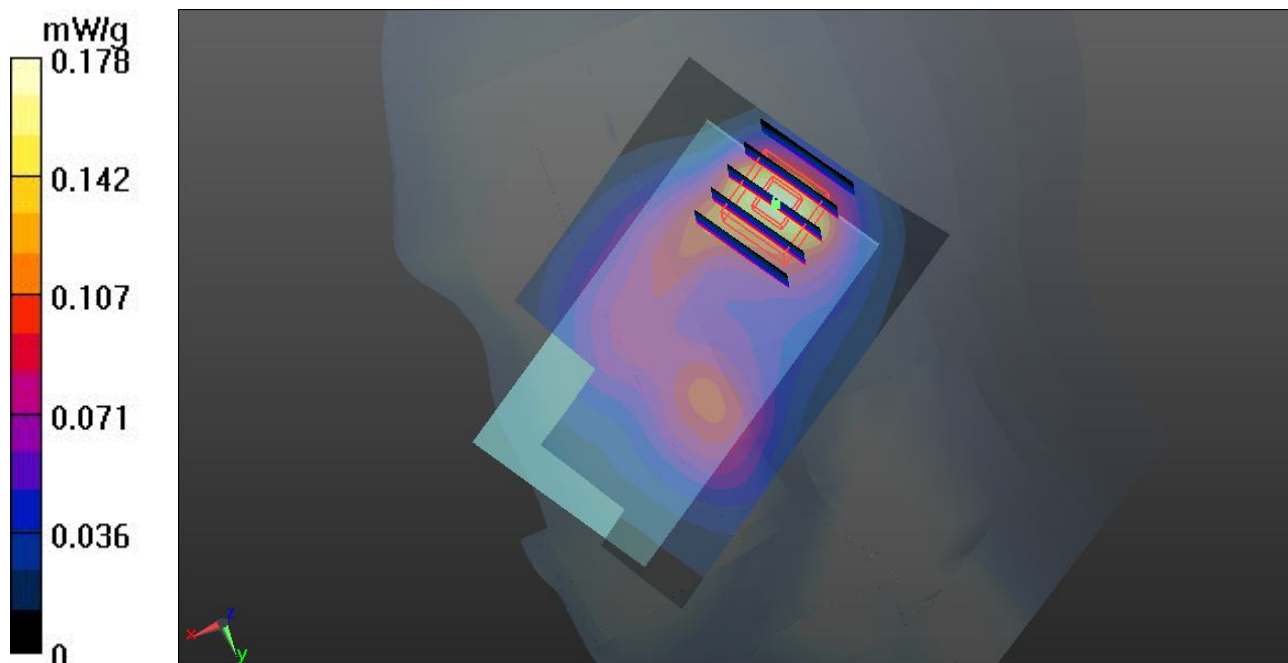

11 GSM1900_Left Cheek_Ch810

DUT: 251703

Communication System: Generic GSM; Frequency: 1909.8 MHz; Duty Cycle: 1:8.3

Medium: HSL_1900_120518 Medium parameters used: $f = 1910$ MHz; $\sigma = 1.43$ mho/m; $\epsilon_r = 40.64$; $\rho = 1000$ kg/m³

Ambient Temperature : 23.5 °C ; Liquid Temperature : 21.5 °C

DASY5 Configuration:

- Probe: ES3DV3 - SN3270; ConvF(5.14, 5.14, 5.14); Calibrated: 12.09.2011
- Sensor-Surface: 4mm (Mechanical Surface Detection)
- Electronics: DAE4 Sn1303; Calibrated: 10.11.2011
- Phantom: SAM1; Type: QD000P40CD; Serial: TP:1670
- Measurement SW: DASY52, Version 52.8 (0); SEMCAD X Version 14.6.4 (4989)

Ch810/Area Scan (61x91x1): Measurement grid: dx=15mm, dy=15mm

Maximum value of SAR (interpolated) = 0.876 mW/g

Ch810/Zoom Scan (5x5x7)/Cube 0: Measurement grid: dx=8mm, dy=8mm, dz=5mm

Reference Value = 8.205 V/m; Power Drift = -0.04 dB

Peak SAR (extrapolated) = 1.1860

SAR(1 g) = 0.776 mW/g; SAR(10 g) = 0.450 mW/g

Maximum value of SAR (measured) = 0.833 mW/g

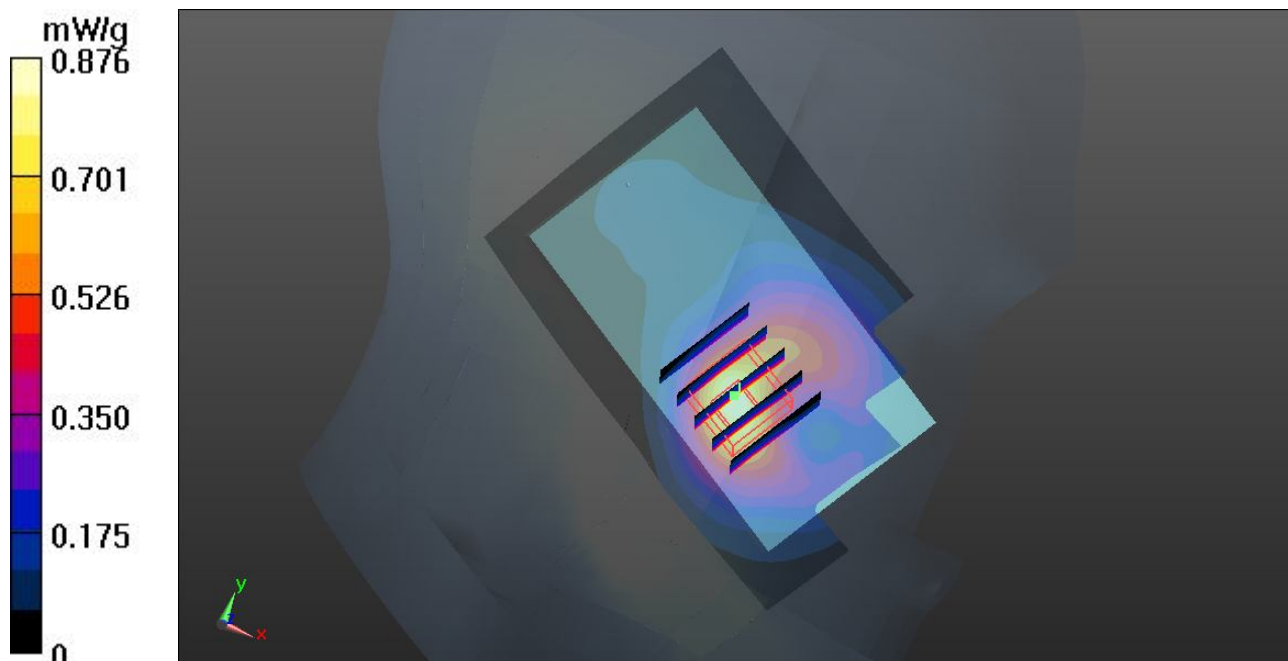

11 GSM1900_Left Cheek_Ch810_2D

DUT: 251703

Communication System: Generic GSM; Frequency: 1909.8 MHz; Duty Cycle: 1:8.3

Medium: HSL_1900_120518 Medium parameters used: $f = 1910$ MHz; $\sigma = 1.43$ mho/m; $\epsilon_r = 40.64$;

$\rho = 1000$ kg/m³

Ambient Temperature : 23.5 °C ; Liquid Temperature : 21.5 °C

DASY5 Configuration:

- Probe: ES3DV3 - SN3270; ConvF(5.14, 5.14, 5.14); Calibrated: 12.09.2011
- Sensor-Surface: 4mm (Mechanical Surface Detection)
- Electronics: DAE4 Sn1303; Calibrated: 10.11.2011
- Phantom: SAM1; Type: QD000P40CD; Serial: TP:1670
- Measurement SW: DASY52, Version 52.8 (0); SEMCAD X Version 14.6.4 (4989)

Ch810/Area Scan (61x91x1): Measurement grid: dx=15mm, dy=15mm

Maximum value of SAR (interpolated) = 0.876 mW/g

Ch810/Zoom Scan (5x5x7)/Cube 0: Measurement grid: dx=8mm, dy=8mm, dz=5mm

Reference Value = 8.205 V/m; Power Drift = -0.04 dB

Peak SAR (extrapolated) = 1.1860

SAR(1 g) = 0.776 mW/g; SAR(10 g) = 0.450 mW/g

Maximum value of SAR (measured) = 0.833 mW/g

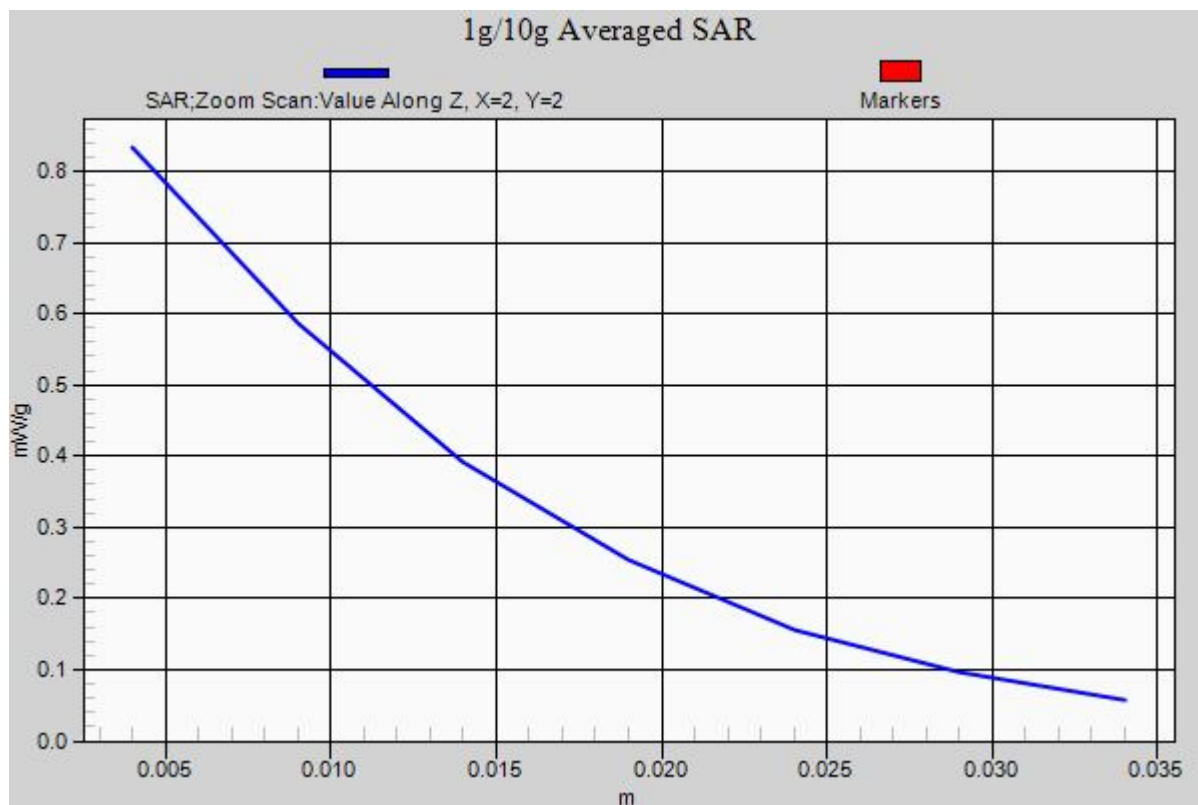

12 GSM1900_Left Tilted_Ch810

DUT: 251703

Communication System: Generic GSM; Frequency: 1909.8 MHz; Duty Cycle: 1:8.3

Medium: HSL_1900_120518 Medium parameters used: $f = 1910$ MHz; $\sigma = 1.43$ mho/m; $\epsilon_r = 40.64$; $\rho = 1000$ kg/m³

Ambient Temperature : 23.5 °C; Liquid Temperature : 21.5 °C

DASY5 Configuration:

- Probe: ES3DV3 - SN3270; ConvF(5.14, 5.14, 5.14); Calibrated: 12.09.2011
- Sensor-Surface: 4mm (Mechanical Surface Detection)
- Electronics: DAE4 Sn1303; Calibrated: 10.11.2011
- Phantom: SAM1; Type: QD000P40CD; Serial: TP:1670
- Measurement SW: DASY52, Version 52.8 (0); SEMCAD X Version 14.6.4 (4989)

Ch810/Area Scan (61x91x1): Measurement grid: dx=15mm, dy=15mm

Maximum value of SAR (interpolated) = 0.182 mW/g

Ch810/Zoom Scan (5x5x7)/Cube 0: Measurement grid: dx=8mm, dy=8mm, dz=5mm

Reference Value = 11.115 V/m; Power Drift = 0.00072 dB

Peak SAR (extrapolated) = 0.2510

SAR(1 g) = 0.155 mW/g; SAR(10 g) = 0.090 mW/g

Maximum value of SAR (measured) = 0.169 mW/g

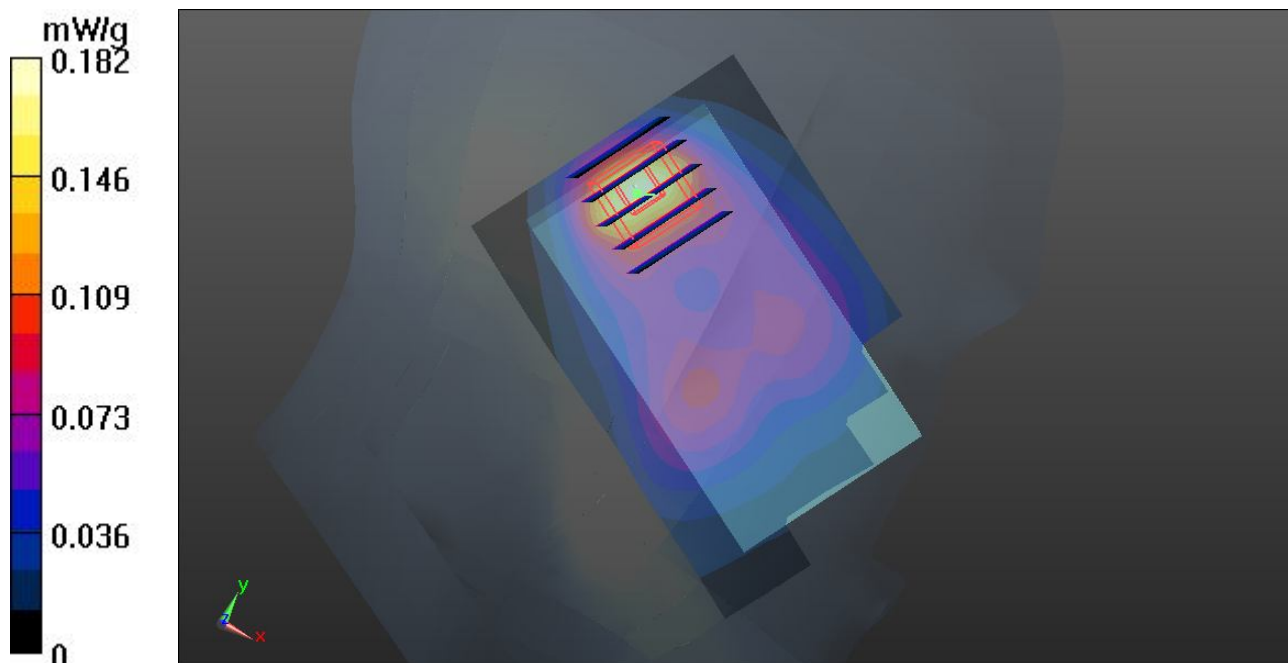

05 WCDMA V_RMC 12.2K_Right Cheek_Ch4182

DUT: 251703

Communication System: UMTS; Frequency: 836.4 MHz; Duty Cycle: 1:1

Medium: HSL_835_120518 Medium parameters used: $f = 836.4$ MHz; $\sigma = 0.929$ mho/m; $\epsilon_r = 42.712$;

$\rho = 1000$ kg/m³

Ambient Temperature : 23.7 °C ; Liquid Temperature : 21.7 °C

DASY5 Configuration:

- Probe: ES3DV3 - SN3270; ConvF(6.04, 6.04, 6.04); Calibrated: 12.09.2011
- Sensor-Surface: 4mm (Mechanical Surface Detection)
- Electronics: DAE4 Sn1303; Calibrated: 10.11.2011
- Phantom: SAM2; Type: QD000P40CD; Serial: TP:1671
- Measurement SW: DASY52, Version 52.8 (0); SEMCAD X Version 14.6.4 (4989)

Ch4182/Area Scan (61x91x1): Measurement grid: dx=15mm, dy=15mm

Maximum value of SAR (interpolated) = 0.665 mW/g

Ch4182/Zoom Scan (5x5x7)/Cube 0: Measurement grid: dx=8mm, dy=8mm, dz=5mm

Reference Value = 9.267 V/m; Power Drift = 0.11 dB

Peak SAR (extrapolated) = 0.8710

SAR(1 g) = 0.643 mW/g; SAR(10 g) = 0.458 mW/g

Maximum value of SAR (measured) = 0.697 mW/g

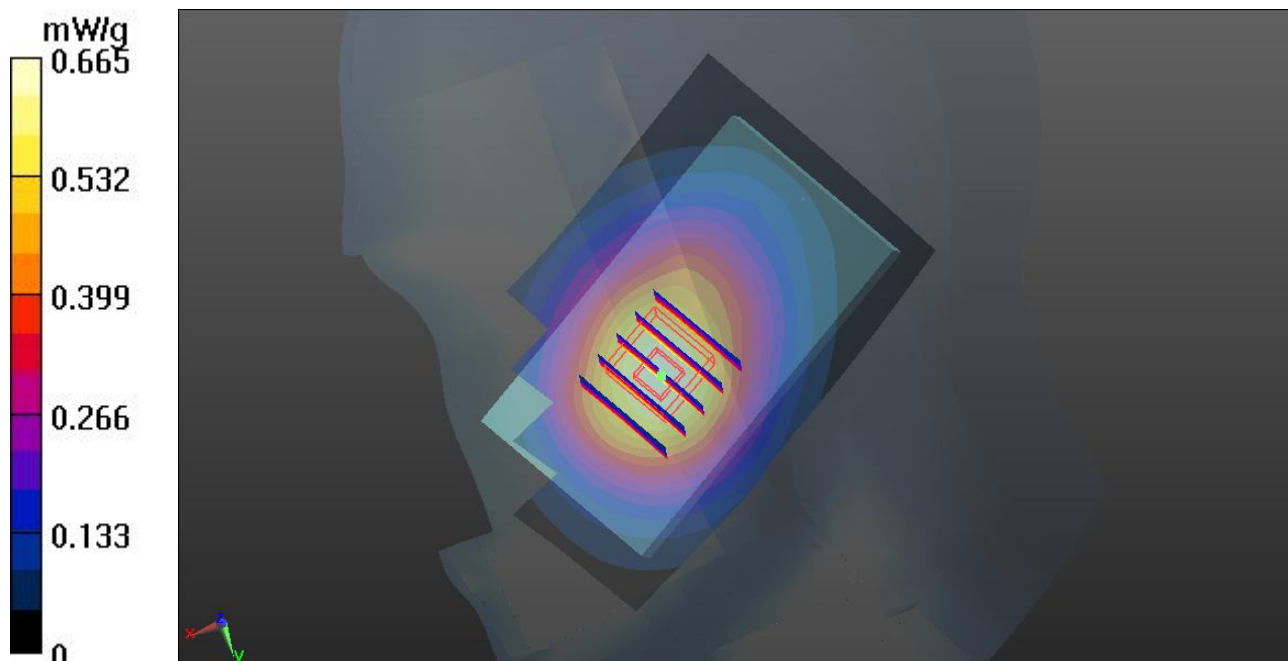

06 WCDMA V_RMC 12.2K_Right Tilted_Ch4182

DUT: 251703

Communication System: UMTS; Frequency: 836.4 MHz; Duty Cycle: 1:1

Medium: HSL_835_120518 Medium parameters used: $f = 836.4$ MHz; $\sigma = 0.929$ mho/m; $\epsilon_r = 42.712$;

$\rho = 1000$ kg/m³

Ambient Temperature : 23.7 °C; Liquid Temperature : 21.7 °C

DASY5 Configuration:

- Probe: ES3DV3 - SN3270; ConvF(6.04, 6.04, 6.04); Calibrated: 12.09.2011
- Sensor-Surface: 4mm (Mechanical Surface Detection)
- Electronics: DAE4 Sn1303; Calibrated: 10.11.2011
- Phantom: SAM2; Type: QD000P40CD; Serial: TP:1671
- Measurement SW: DASY52, Version 52.8 (0); SEMCAD X Version 14.6.4 (4989)

Ch4182/Area Scan (61x91x1): Measurement grid: dx=15mm, dy=15mm

Maximum value of SAR (interpolated) = 0.369 mW/g

Ch4182/Zoom Scan (5x5x7)/Cube 0: Measurement grid: dx=8mm, dy=8mm, dz=5mm

Reference Value = 13.791 V/m; Power Drift = 0.04 dB

Peak SAR (extrapolated) = 0.4600

SAR(1 g) = 0.355 mW/g; SAR(10 g) = 0.264 mW/g

Maximum value of SAR (measured) = 0.375 mW/g

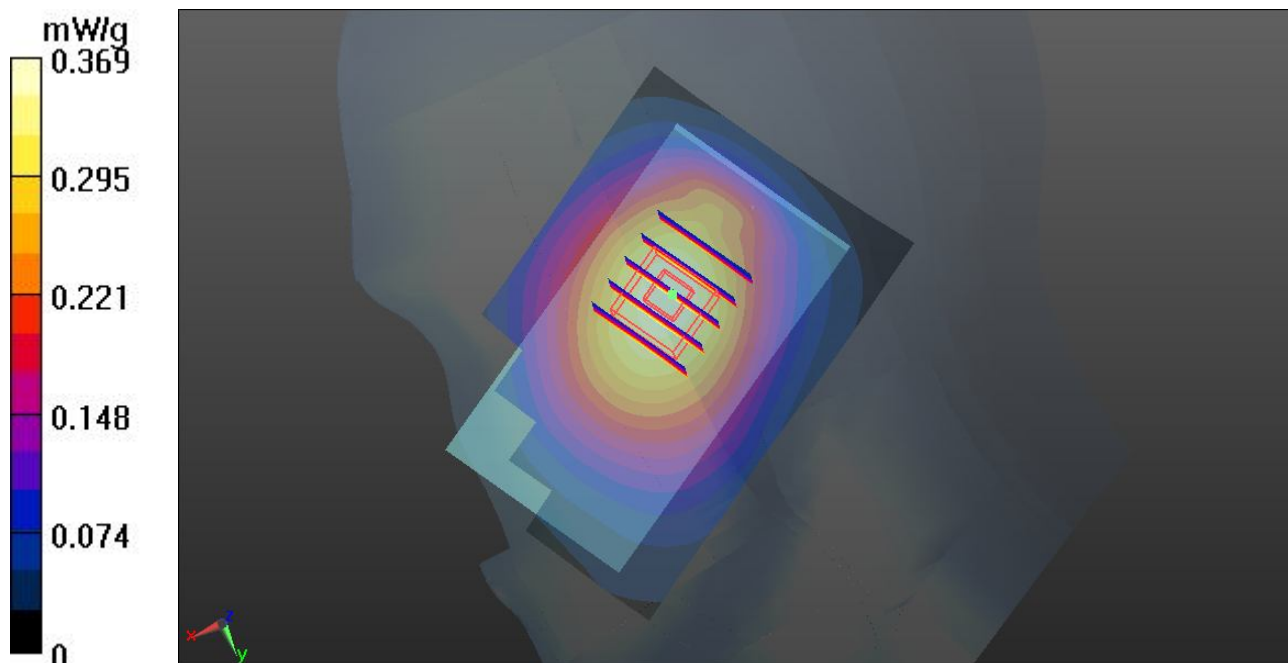

07 WCDMA V_RMC 12.2K_Left Cheek_Ch4182

DUT: 251703

Communication System: UMTS; Frequency: 836.4 MHz; Duty Cycle: 1:1

Medium: HSL_835_120518 Medium parameters used: $f = 836.4$ MHz; $\sigma = 0.929$ mho/m; $\epsilon_r = 42.712$;

$\rho = 1000$ kg/m³

Ambient Temperature : 23.7 °C ; Liquid Temperature : 21.7 °C

DASY5 Configuration:

- Probe: ES3DV3 - SN3270; ConvF(6.04, 6.04, 6.04); Calibrated: 12.09.2011
- Sensor-Surface: 4mm (Mechanical Surface Detection)
- Electronics: DAE4 Sn1303; Calibrated: 10.11.2011
- Phantom: SAM2; Type: QD000P40CD; Serial: TP:1671
- Measurement SW: DASY52, Version 52.8 (0); SEMCAD X Version 14.6.4 (4989)

Ch4182/Area Scan (61x91x1): Measurement grid: dx=15mm, dy=15mm

Maximum value of SAR (interpolated) = 0.724 mW/g

Ch4182/Zoom Scan (5x5x7)/Cube 0: Measurement grid: dx=8mm, dy=8mm, dz=5mm

Reference Value = 9.145 V/m; Power Drift = 0.07 dB

Peak SAR (extrapolated) = 0.9150

SAR(1 g) = 0.704 mW/g; SAR(10 g) = 0.509 mW/g

Maximum value of SAR (measured) = 0.745 mW/g

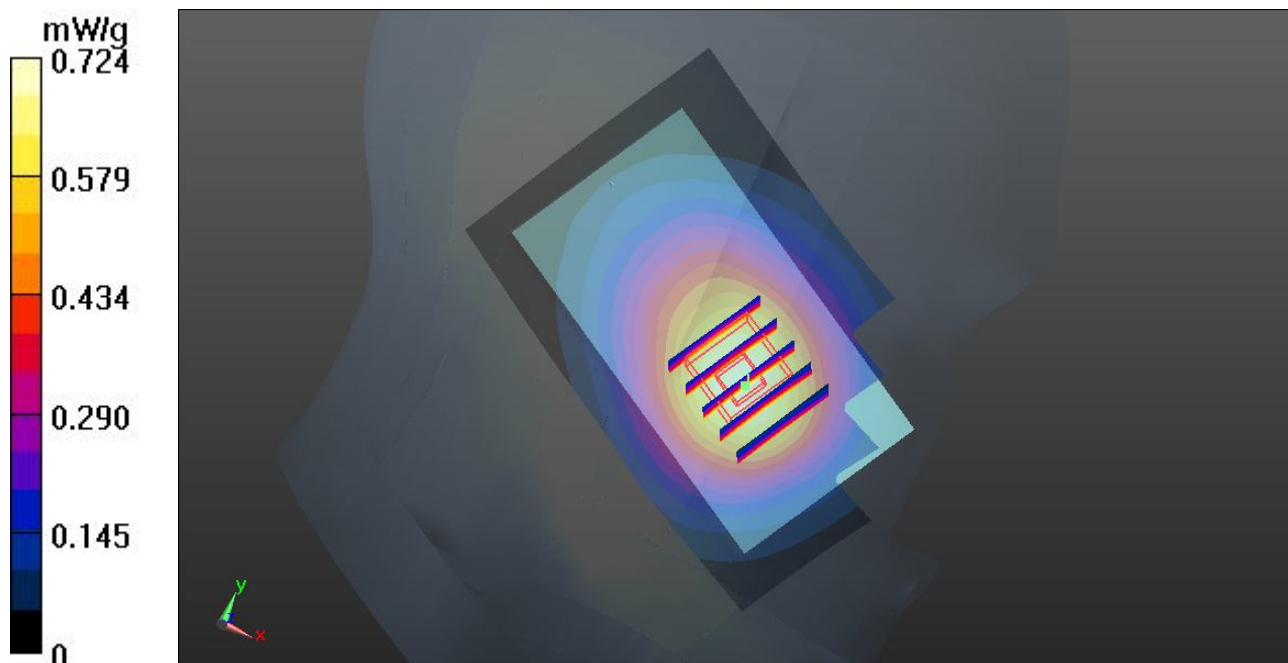

07 WCDMA V_RMC 12.2K_Left Cheek_Ch4182_2D

DUT: 251703

Communication System: UMTS; Frequency: 836.4 MHz; Duty Cycle: 1:1
 Medium: HSL_835_120518 Medium parameters used: $f = 836.4$ MHz; $\sigma = 0.929$ mho/m; $\epsilon_r = 42.712$; $\rho = 1000$ kg/m³
 Ambient Temperature : 23.7 °C ; Liquid Temperature : 21.7 °C

DASY5 Configuration:

- Probe: ES3DV3 - SN3270; ConvF(6.04, 6.04, 6.04); Calibrated: 12.09.2011
- Sensor-Surface: 4mm (Mechanical Surface Detection)
- Electronics: DAE4 Sn1303; Calibrated: 10.11.2011
- Phantom: SAM2; Type: QD000P40CD; Serial: TP:1671
- Measurement SW: DASY52, Version 52.8 (0); SEMCAD X Version 14.6.4 (4989)

Ch4182/Area Scan (61x91x1): Measurement grid: dx=15mm, dy=15mm
 Maximum value of SAR (interpolated) = 0.724 mW/g

Ch4182/Zoom Scan (5x5x7)/Cube 0: Measurement grid: dx=8mm, dy=8mm, dz=5mm
 Reference Value = 9.145 V/m; Power Drift = 0.07 dB
 Peak SAR (extrapolated) = 0.9150
SAR(1 g) = 0.704 mW/g; SAR(10 g) = 0.509 mW/g
 Maximum value of SAR (measured) = 0.745 mW/g

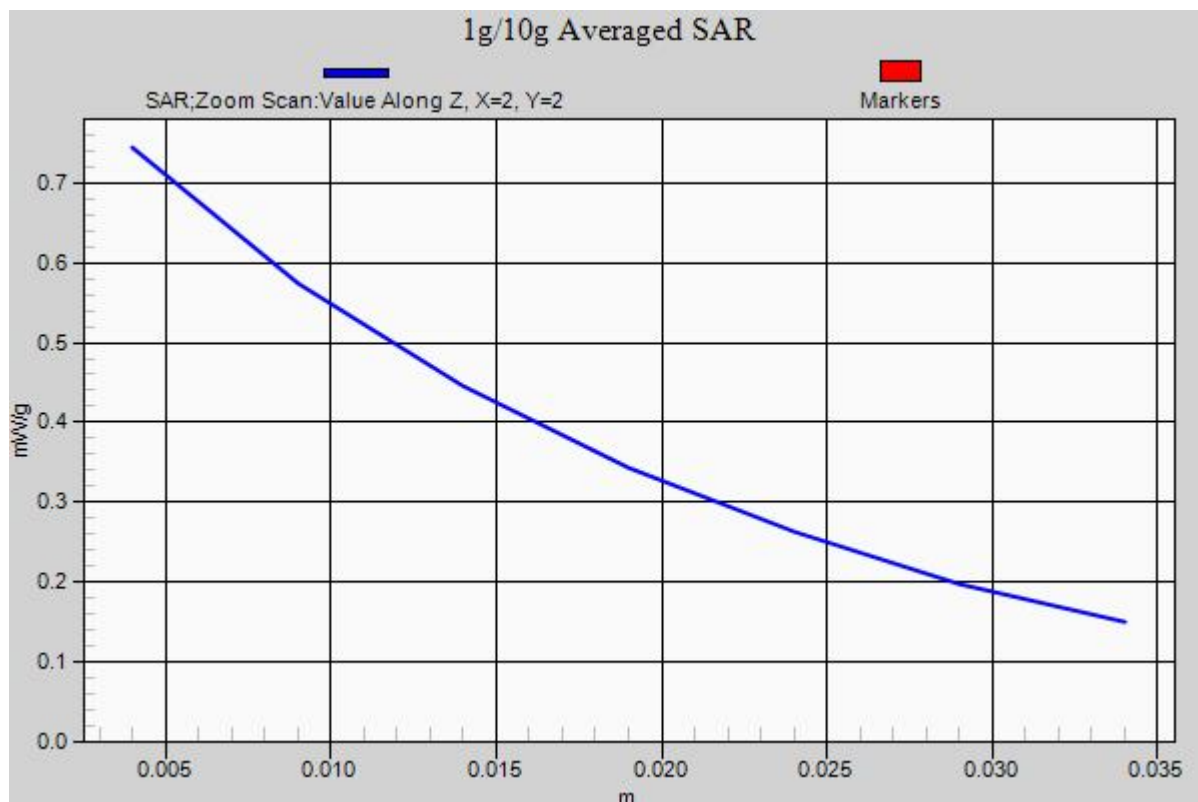

08 WCDMA V_RMC 12.2K_Left Tilted_Ch4182

DUT: 251703

Communication System: UMTS; Frequency: 836.4 MHz; Duty Cycle: 1:1

Medium: HSL_835_120518 Medium parameters used: $f = 836.4$ MHz; $\sigma = 0.929$ mho/m; $\epsilon_r = 42.712$;

$\rho = 1000$ kg/m³

Ambient Temperature : 23.7 °C; Liquid Temperature : 21.7 °C

DASY5 Configuration:

- Probe: ES3DV3 - SN3270; ConvF(6.04, 6.04, 6.04); Calibrated: 12.09.2011
- Sensor-Surface: 4mm (Mechanical Surface Detection)
- Electronics: DAE4 Sn1303; Calibrated: 10.11.2011
- Phantom: SAM2; Type: QD000P40CD; Serial: TP:1671
- Measurement SW: DASY52, Version 52.8 (0); SEMCAD X Version 14.6.4 (4989)

Ch4182/Area Scan (61x91x1): Measurement grid: dx=15mm, dy=15mm

Maximum value of SAR (interpolated) = 0.390 mW/g

Ch4182/Zoom Scan (5x5x7)/Cube 0: Measurement grid: dx=8mm, dy=8mm, dz=5mm

Reference Value = 13.589 V/m; Power Drift = -0.0014 dB

Peak SAR (extrapolated) = 0.4870

SAR(1 g) = 0.379 mW/g; SAR(10 g) = 0.282 mW/g

Maximum value of SAR (measured) = 0.399 mW/g

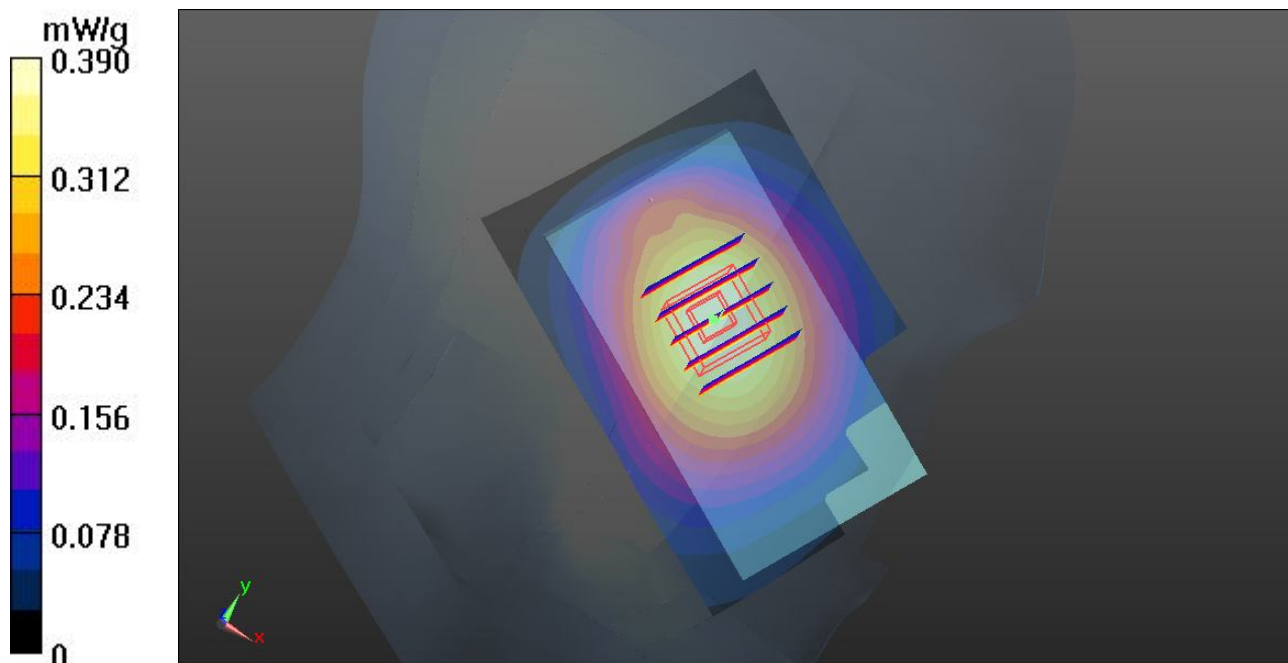

13 WCDMA II_RMC 12.2K_Right Cheek_Ch9538

DUT: 251703

Communication System: UMTS; Frequency: 1907.6 MHz; Duty Cycle: 1:1

Medium: HSL_1900_120525 Medium parameters used: $f = 1908$ MHz; $\sigma = 1.423$ mho/m; $\epsilon_r =$

40.497; $\rho = 1000$ kg/m³

Ambient Temperature : 23.4 °C; Liquid Temperature : 21.5 °C

DASY5 Configuration:

- Probe: ES3DV3 - SN3270; ConvF(5.14, 5.14, 5.14); Calibrated: 12.09.2011;
- Sensor-Surface: 4mm (Mechanical Surface Detection)
- Electronics: DAE4 Sn1303; Calibrated: 10.11.2011
- Phantom: SAM2; Type: QD000P40CD; Serial: TP:1671
- Measurement SW: DASY52, Version 52.8 (1); SEMCAD X Version 14.6.5 (6469)

Ch9538/Area Scan (61x91x1): Measurement grid: dx=15mm, dy=15mm

Maximum value of SAR (interpolated) = 1.31 mW/g

Ch9538/Zoom Scan (5x5x7)/Cube 0: Measurement grid: dx=8mm, dy=8mm, dz=5mm

Reference Value = 10.696 V/m; Power Drift = -0.05 dB

Peak SAR (extrapolated) = 1.653 mW/g

SAR(1 g) = 1.090 mW/g; SAR(10 g) = 0.643 mW/g

Maximum value of SAR (measured) = 1.20 mW/g

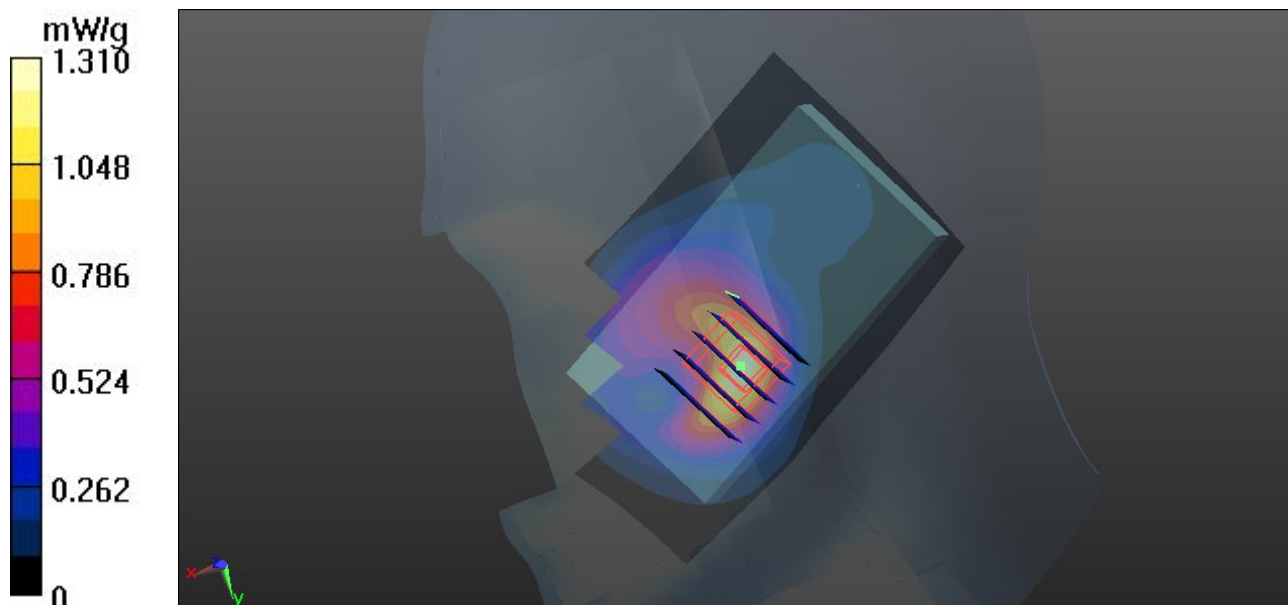

14 WCDMA II_RMC 12.2K_Right Tilted_Ch9538

DUT: 251703

Communication System: UMTS; Frequency: 1907.6 MHz; Duty Cycle: 1:1

Medium: HSL_1900_120525 Medium parameters used: $f = 1908$ MHz; $\sigma = 1.423$ mho/m; $\epsilon_r =$

40.497 ; $\rho = 1000$ kg/m³

Ambient Temperature : 23.4 °C; Liquid Temperature : 21.5 °C

DASY5 Configuration:

- Probe: ES3DV3 - SN3270; ConvF(5.14, 5.14, 5.14); Calibrated: 12.09.2011;
- Sensor-Surface: 4mm (Mechanical Surface Detection)
- Electronics: DAE4 Sn1303; Calibrated: 10.11.2011
- Phantom: SAM2; Type: QD000P40CD; Serial: TP:1671
- Measurement SW: DASY52, Version 52.8 (1); SEMCAD X Version 14.6.5 (6469)

Ch9538/Area Scan (61x91x1): Measurement grid: dx=15mm, dy=15mm

Maximum value of SAR (interpolated) = 0.245 mW/g

Ch9538/Zoom Scan (5x5x7)/Cube 0: Measurement grid: dx=8mm, dy=8mm, dz=5mm

Reference Value = 13.039 V/m; Power Drift = -0.01 dB

Peak SAR (extrapolated) = 0.332 mW/g

SAR(1 g) = 0.204 mW/g; SAR(10 g) = 0.120 mW/g

Maximum value of SAR (measured) = 0.223 mW/g

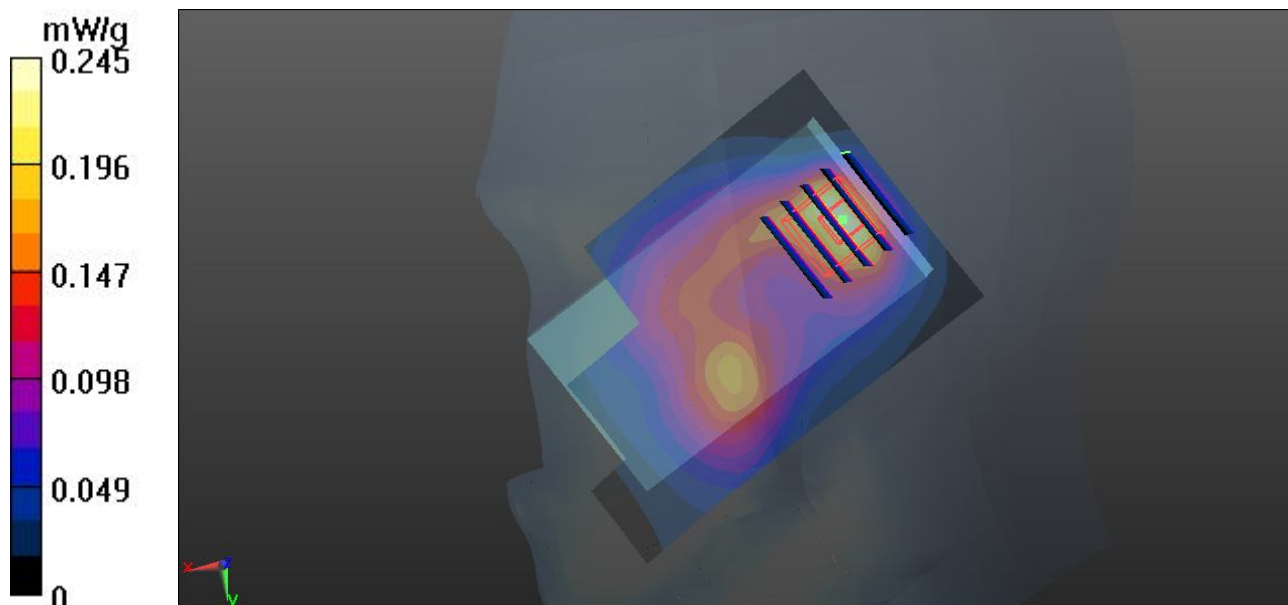

15 WCDMA II_RMC 12.2K_Left Cheek_Ch9538

DUT: 251703

Communication System: UMTS; Frequency: 1907.6 MHz; Duty Cycle: 1:1

Medium: HSL_1900_120525 Medium parameters used: $f = 1908$ MHz; $\sigma = 1.423$ mho/m; $\epsilon_r =$

40.497 ; $\rho = 1000$ kg/m³

Ambient Temperature : 23.4 °C; Liquid Temperature : 21.5 °C

DASY5 Configuration:

- Probe: ES3DV3 - SN3270; ConvF(5.14, 5.14, 5.14); Calibrated: 12.09.2011;
- Sensor-Surface: 4mm (Mechanical Surface Detection)
- Electronics: DAE4 Sn1303; Calibrated: 10.11.2011
- Phantom: SAM2; Type: QD000P40CD; Serial: TP:1671
- Measurement SW: DASY52, Version 52.8 (1); SEMCAD X Version 14.6.5 (6469)

Ch9538/Area Scan (61x91x1): Measurement grid: dx=15mm, dy=15mm

Maximum value of SAR (interpolated) = 1.26 mW/g

Ch9538/Zoom Scan (5x5x7)/Cube 0: Measurement grid: dx=8mm, dy=8mm, dz=5mm

Reference Value = 9.462 V/m; Power Drift = -0.10 dB

Peak SAR (extrapolated) = 1.713 mW/g

SAR(1 g) = 1.150 mW/g; SAR(10 g) = 0.674 mW/g

Maximum value of SAR (measured) = 1.24 mW/g

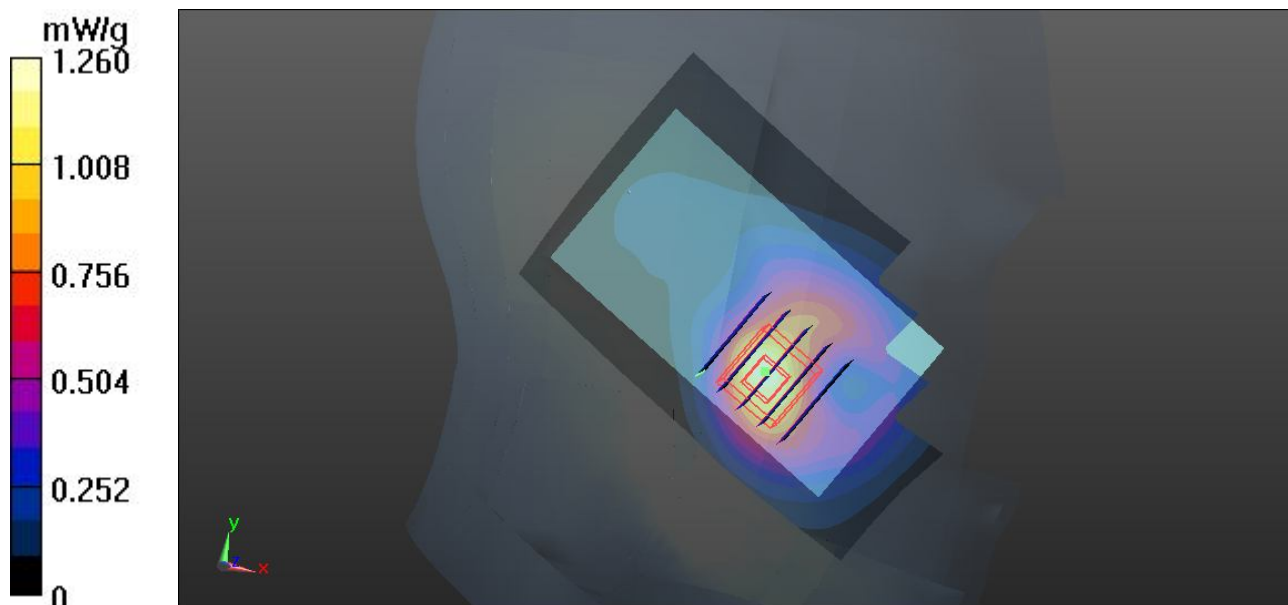

16 WCDMA II_RMC 12.2K_Left Tilted_Ch9538

DUT: 251703

Communication System: UMTS; Frequency: 1907.6 MHz; Duty Cycle: 1:1

Medium: HSL_1900_120525 Medium parameters used: $f = 1908$ MHz; $\sigma = 1.423$ mho/m; $\epsilon_r =$

40.497; $\rho = 1000$ kg/m³

Ambient Temperature : 23.4 °C; Liquid Temperature : 21.5 °C

DASY5 Configuration:

- Probe: ES3DV3 - SN3270; ConvF(5.14, 5.14, 5.14); Calibrated: 12.09.2011;
- Sensor-Surface: 4mm (Mechanical Surface Detection)
- Electronics: DAE4 Sn1303; Calibrated: 10.11.2011
- Phantom: SAM2; Type: QD000P40CD; Serial: TP:1671
- Measurement SW: DASY52, Version 52.8 (1); SEMCAD X Version 14.6.5 (6469)

Ch9538/Area Scan (61x91x1): Measurement grid: dx=15mm, dy=15mm

Maximum value of SAR (interpolated) = 0.256 mW/g

Ch9538/Zoom Scan (5x5x7)/Cube 0: Measurement grid: dx=8mm, dy=8mm, dz=5mm

Reference Value = 13.218 V/m; Power Drift = -0.01 dB

Peak SAR (extrapolated) = 0.348 mW/g

SAR(1 g) = 0.218 mW/g; SAR(10 g) = 0.128 mW/g

Maximum value of SAR (measured) = 0.240 mW/g

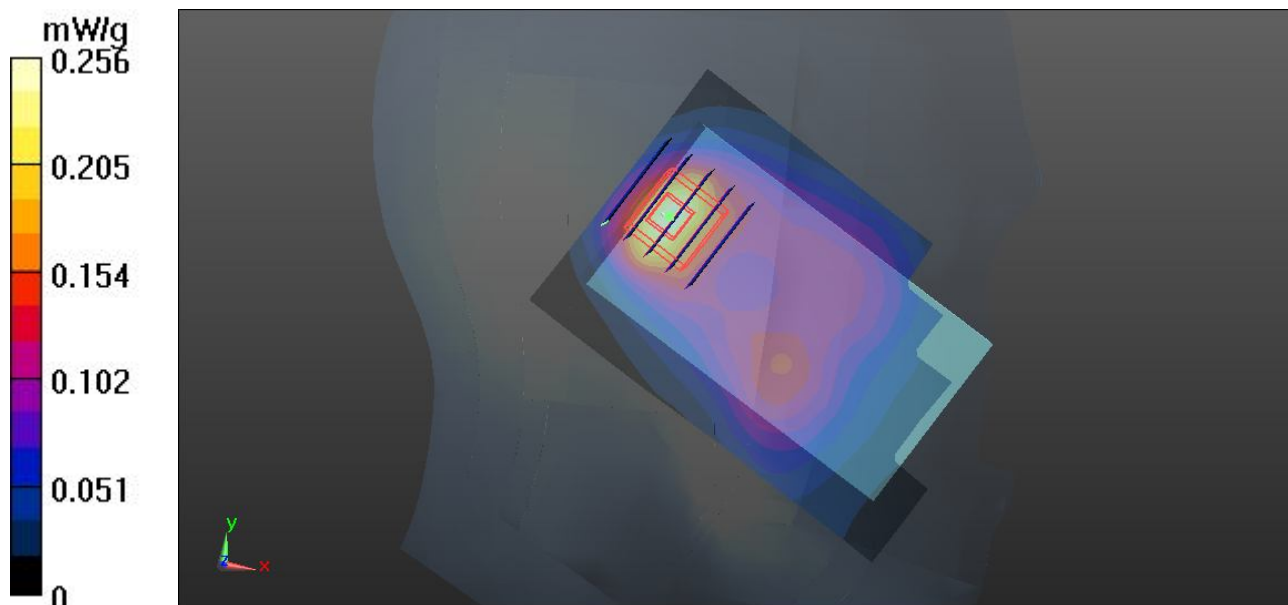

17 WCDMA II_RMC 12.2K_Right Cheek_Ch9262

DUT: 251703

Communication System: UMTS; Frequency: 1852.4 MHz; Duty Cycle: 1:1

Medium: HSL_1900_120525 Medium parameters used: $f = 1852.4$ MHz; $\sigma = 1.371$ mho/m; $\epsilon_r =$

40.687 ; $\rho = 1000$ kg/m³

Ambient Temperature : 23.4 °C; Liquid Temperature : 21.5 °C

DASY5 Configuration:

- Probe: ES3DV3 - SN3270; ConvF(5.14, 5.14, 5.14); Calibrated: 12.09.2011;
- Sensor-Surface: 4mm (Mechanical Surface Detection)
- Electronics: DAE4 Sn1303; Calibrated: 10.11.2011
- Phantom: SAM2; Type: QD000P40CD; Serial: TP:1671
- Measurement SW: DASY52, Version 52.8 (1); SEMCAD X Version 14.6.5 (6469)

Ch9262/Area Scan (61x91x1): Measurement grid: dx=15mm, dy=15mm

Maximum value of SAR (interpolated) = 1.60 mW/g

Ch9262/Zoom Scan (5x5x7)/Cube 0: Measurement grid: dx=8mm, dy=8mm, dz=5mm

Reference Value = 11.135 V/m; Power Drift = -0.03 dB

Peak SAR (extrapolated) = 2.010 mW/g

SAR(1 g) = 1.370 mW/g; SAR(10 g) = 0.818 mW/g

Maximum value of SAR (measured) = 1.50 mW/g

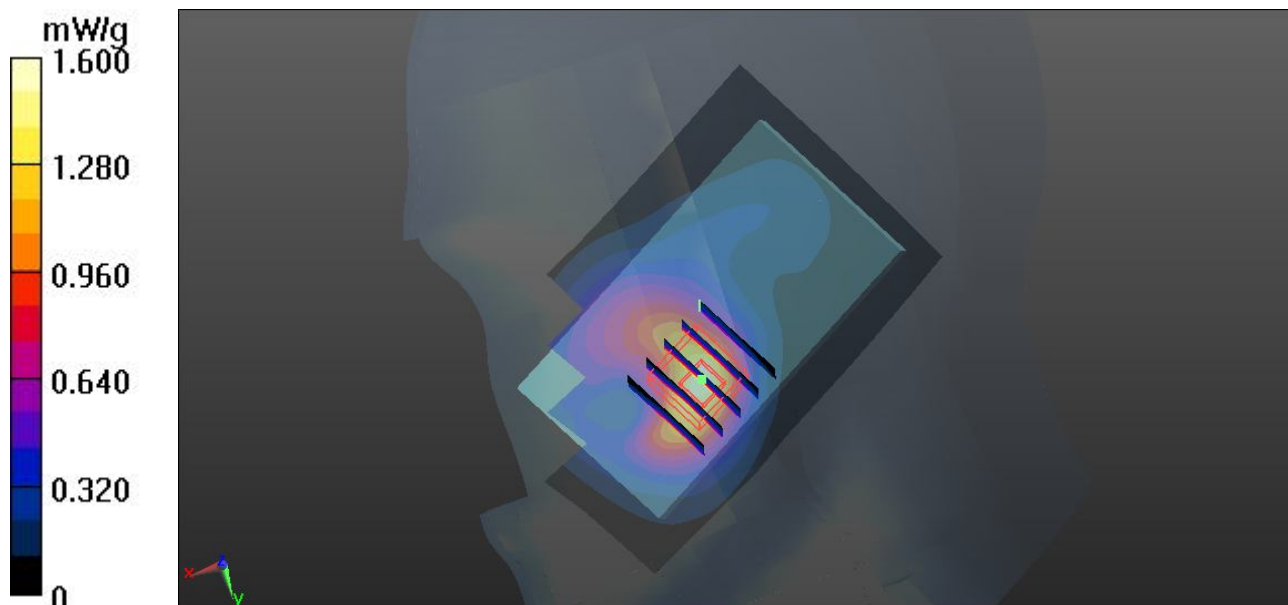

17 WCDMA II_RMC 12.2K_Right Cheek_Ch9262_2D

DUT: 251703

Communication System: UMTS; Frequency: 1852.4 MHz; Duty Cycle: 1:1
Medium: HSL_1900_120525 Medium parameters used: $f = 1852.4$ MHz; $\sigma = 1.371$ mho/m; $\epsilon_r = 40.687$; $\rho = 1000$ kg/m³
Ambient Temperature : 23.4 °C; Liquid Temperature : 21.5 °C

DASY5 Configuration:

- Probe: ES3DV3 - SN3270; ConvF(5.14, 5.14, 5.14); Calibrated: 12.09.2011;
- Sensor-Surface: 4mm (Mechanical Surface Detection)
- Electronics: DAE4 Sn1303; Calibrated: 10.11.2011
- Phantom: SAM2; Type: QD000P40CD; Serial: TP:1671
- Measurement SW: DASY52, Version 52.8 (1); SEMCAD X Version 14.6.5 (6469)

Ch9262/Area Scan (61x91x1): Measurement grid: dx=15mm, dy=15mm
Maximum value of SAR (interpolated) = 1.60 mW/g

Ch9262/Zoom Scan (5x5x7)/Cube 0: Measurement grid: dx=8mm, dy=8mm, dz=5mm
Reference Value = 11.135 V/m; Power Drift = -0.03 dB
Peak SAR (extrapolated) = 2.010 mW/g
SAR(1 g) = 1.370 mW/g; SAR(10 g) = 0.818 mW/g
Maximum value of SAR (measured) = 1.50 mW/g

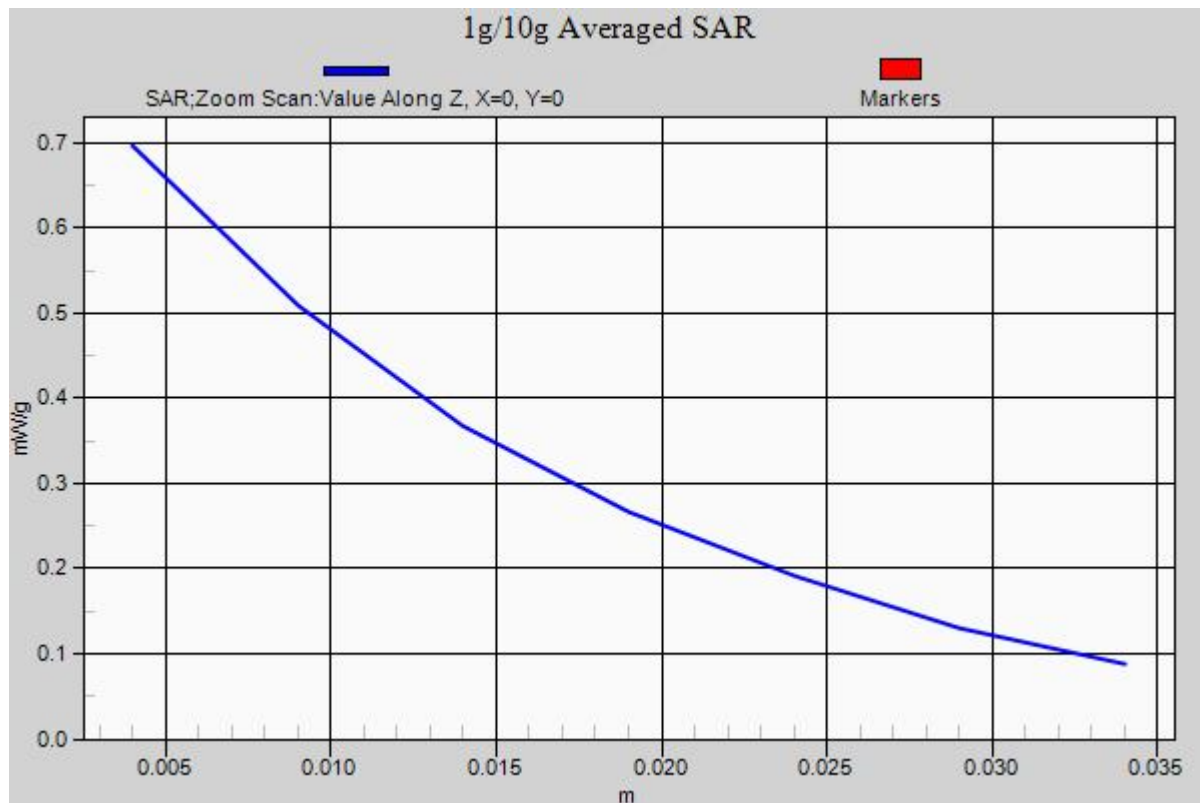

18 WCDMA II_RMC 12.2K_Right Cheek_Ch9400

DUT: 251703

Communication System: UMTS; Frequency: 1880 MHz; Duty Cycle: 1:1

Medium: HSL_1900_120525 Medium parameters used: $f = 1880$ MHz; $\sigma = 1.397$ mho/m; $\epsilon_r =$

40.608 ; $\rho = 1000$ kg/m³

Ambient Temperature : 23.4 °C; Liquid Temperature : 21.5 °C

DASY5 Configuration:

- Probe: ES3DV3 - SN3270; ConvF(5.14, 5.14, 5.14); Calibrated: 12.09.2011;
- Sensor-Surface: 4mm (Mechanical Surface Detection)
- Electronics: DAE4 Sn1303; Calibrated: 10.11.2011
- Phantom: SAM2; Type: QD000P40CD; Serial: TP:1671
- Measurement SW: DASY52, Version 52.8 (1); SEMCAD X Version 14.6.5 (6469)

Ch9400/Area Scan (61x91x1): Measurement grid: dx=15mm, dy=15mm

Maximum value of SAR (interpolated) = 1.58 mW/g

Ch9400/Zoom Scan (5x5x7)/Cube 0: Measurement grid: dx=8mm, dy=8mm, dz=5mm

Reference Value = 11.652 V/m; Power Drift = -0.01 dB

Peak SAR (extrapolated) = 1.903 mW/g

SAR(1 g) = 1.290 mW/g; SAR(10 g) = 0.771 mW/g

Maximum value of SAR (measured) = 1.41 mW/g

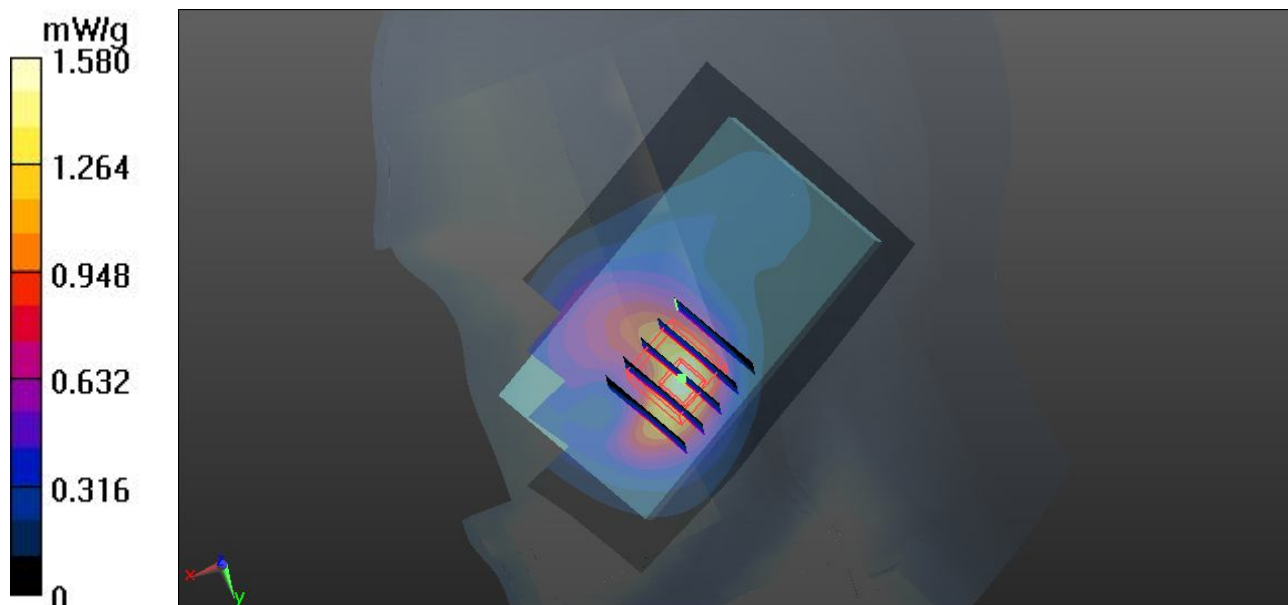

19 WCDMA II_RMC 12.2K_Left Cheek_Ch9262

DUT: 251703

Communication System: UMTS; Frequency: 1852.4 MHz; Duty Cycle: 1:1

Medium: HSL_1900_120525 Medium parameters used: $f = 1852.4$ MHz; $\sigma = 1.371$ mho/m; $\epsilon_r =$

40.687 ; $\rho = 1000$ kg/m³

Ambient Temperature : 23.4 °C; Liquid Temperature : 21.5 °C

DASY5 Configuration:

- Probe: ES3DV3 - SN3270; ConvF(5.14, 5.14, 5.14); Calibrated: 12.09.2011;
- Sensor-Surface: 4mm (Mechanical Surface Detection)
- Electronics: DAE4 Sn1303; Calibrated: 10.11.2011
- Phantom: SAM2; Type: QD000P40CD; Serial: TP:1671
- Measurement SW: DASY52, Version 52.8 (1); SEMCAD X Version 14.6.5 (6469)

Ch9262/Area Scan (61x91x1): Measurement grid: dx=15mm, dy=15mm

Maximum value of SAR (interpolated) = 1.36 mW/g

Ch9262/Zoom Scan (5x5x7)/Cube 0: Measurement grid: dx=8mm, dy=8mm, dz=5mm

Reference Value = 12.117 V/m; Power Drift = -0.06 dB

Peak SAR (extrapolated) = 1.793 mW/g

SAR(1 g) = 1.240 mW/g; SAR(10 g) = 0.751 mW/g

Maximum value of SAR (measured) = 1.33 mW/g

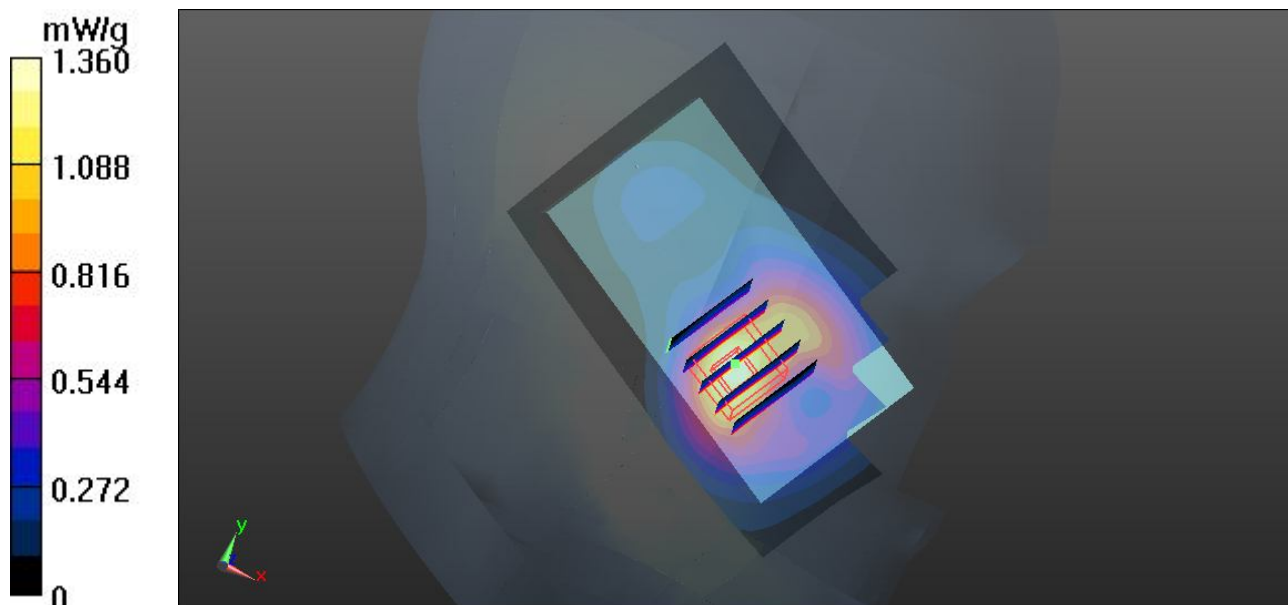

20 WCDMA II_RMC 12.2K_Left Cheek_Ch9400

DUT: 251703

Communication System: UMTS; Frequency: 1880 MHz; Duty Cycle: 1:1

Medium: HSL_1900_120525 Medium parameters used: $f = 1880$ MHz; $\sigma = 1.397$ mho/m; $\epsilon_r =$

40.608 ; $\rho = 1000$ kg/m³

Ambient Temperature : 23.4 °C; Liquid Temperature : 21.5 °C

DASY5 Configuration:

- Probe: ES3DV3 - SN3270; ConvF(5.14, 5.14, 5.14); Calibrated: 12.09.2011;
- Sensor-Surface: 4mm (Mechanical Surface Detection)
- Electronics: DAE4 Sn1303; Calibrated: 10.11.2011
- Phantom: SAM2; Type: QD000P40CD; Serial: TP:1671
- Measurement SW: DASY52, Version 52.8 (1); SEMCAD X Version 14.6.5 (6469)

Ch9400/Area Scan (61x91x1): Measurement grid: dx=15mm, dy=15mm

Maximum value of SAR (interpolated) = 1.37 mW/g

Ch9400/Zoom Scan (5x5x7)/Cube 0: Measurement grid: dx=8mm, dy=8mm, dz=5mm

Reference Value = 11.450 V/m; Power Drift = -0.01 dB

Peak SAR (extrapolated) = 1.826 mW/g

SAR(1 g) = 1.250 mW/g; SAR(10 g) = 0.751 mW/g

Maximum value of SAR (measured) = 1.34 mW/g

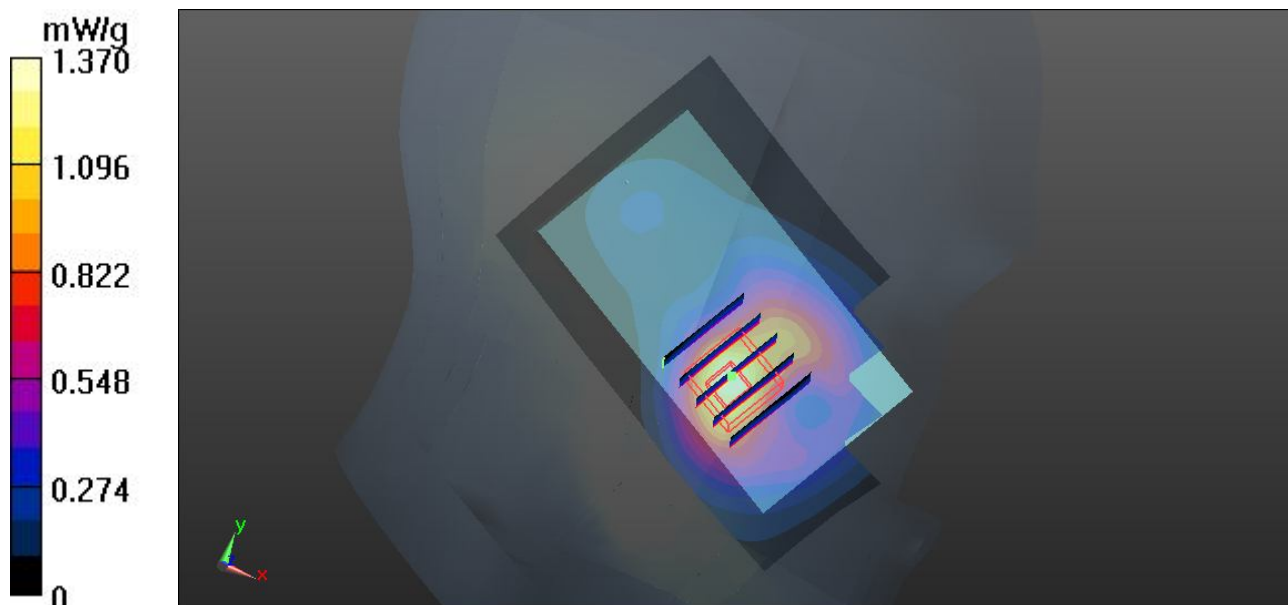

64 802.11b_Right Cheek_Ch1

DUT: 251703

Communication System: WIFI; Frequency: 2412 MHz; Duty Cycle: 1:1

Medium: HSL_2450_120723 Medium parameters used: $f = 2412$ MHz; $\sigma = 1.791$ mho/m; $\epsilon_r =$

39.777 ; $\rho = 1000$ kg/m³

Ambient Temperature : 23.3 °C ; Liquid Temperature : 21.3 °C

DASY5 Configuration:

- Probe: ES3DV3 - SN3270; ConvF(4.52, 4.52, 4.52); Calibrated: 12.09.2011;
- Sensor-Surface: 4mm (Mechanical Surface Detection)
- Electronics: DAE4 Sn1303; Calibrated: 10.11.2011
- Phantom: SAM1; Type: QD000P40CD; Serial: TP:1670
- Measurement SW: DASY52, Version 52.8 (1); SEMCAD X Version 14.6.5 (6469)

Ch1/Area Scan (61x91x1): Measurement grid: dx=15mm, dy=15mm

Maximum value of SAR (interpolated) = 0.113 mW/g

Ch1/Zoom Scan (5x5x7)/Cube 0: Measurement grid: dx=8mm, dy=8mm, dz=5mm

Reference Value = 5.215 V/m; Power Drift = -0.15 dB

Peak SAR (extrapolated) = 0.206 mW/g

SAR(1 g) = 0.102 mW/g; SAR(10 g) = 0.053 mW/g

Maximum value of SAR (measured) = 0.108 mW/g

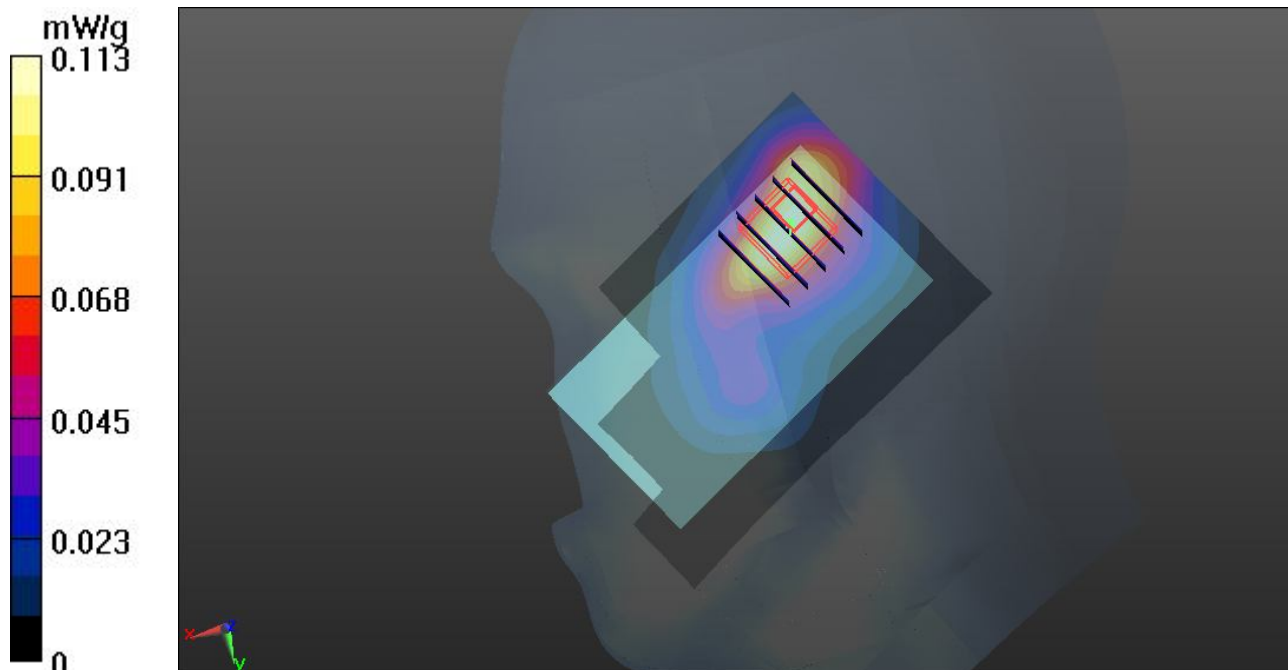

64 802.11b_Right Cheek_Ch1_2D

DUT: 251703

Communication System: WIFI; Frequency: 2412 MHz; Duty Cycle: 1:1

Medium: HSL_2450_120723 Medium parameters used: $f = 2412$ MHz; $\sigma = 1.791$ mho/m; $\epsilon_r =$

39.777 ; $\rho = 1000$ kg/m³

Ambient Temperature : 23.3 °C ; Liquid Temperature : 21.3 °C

DASY5 Configuration:

- Probe: ES3DV3 - SN3270; ConvF(4.52, 4.52, 4.52); Calibrated: 12.09.2011;
- Sensor-Surface: 4mm (Mechanical Surface Detection)
- Electronics: DAE4 Sn1303; Calibrated: 10.11.2011
- Phantom: SAM1; Type: QD000P40CD; Serial: TP:1670
- Measurement SW: DASY52, Version 52.8 (1); SEMCAD X Version 14.6.5 (6469)

Ch1/Area Scan (61x91x1): Measurement grid: dx=15mm, dy=15mm

Maximum value of SAR (interpolated) = 0.113 mW/g

Ch1/Zoom Scan (5x5x7)/Cube 0: Measurement grid: dx=8mm, dy=8mm, dz=5mm

Reference Value = 5.215 V/m; Power Drift = -0.15 dB

Peak SAR (extrapolated) = 0.206 mW/g

SAR(1 g) = 0.102 mW/g; SAR(10 g) = 0.053 mW/g

Maximum value of SAR (measured) = 0.108 mW/g

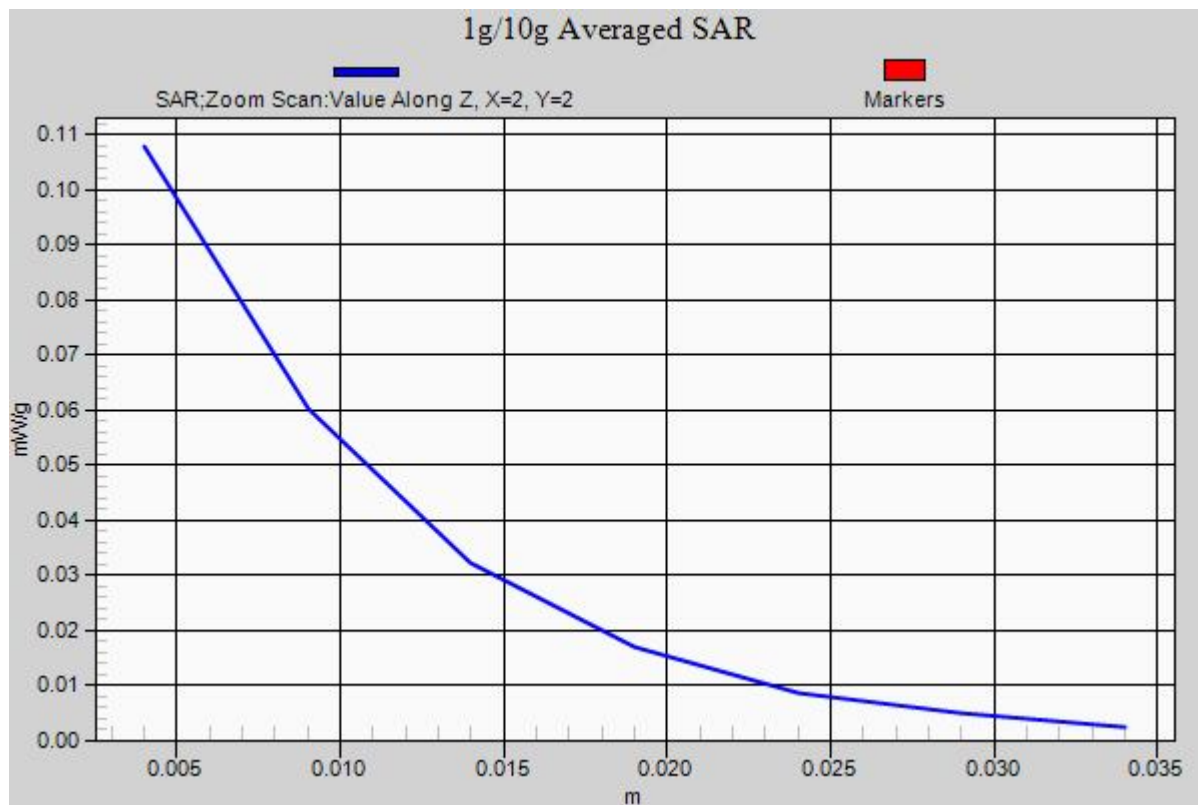

65 802.11b_Right Tilted_Ch1

DUT: 251703

Communication System: WIFI; Frequency: 2412 MHz; Duty Cycle: 1:1

Medium: HSL_2450_120723 Medium parameters used: $f = 2412$ MHz; $\sigma = 1.791$ mho/m; $\epsilon_r =$

39.777 ; $\rho = 1000$ kg/m³

Ambient Temperature : 23.3 °C ; Liquid Temperature : 21.3 °C

DASY5 Configuration:

- Probe: ES3DV3 - SN3270; ConvF(4.52, 4.52, 4.52); Calibrated: 12.09.2011;
- Sensor-Surface: 4mm (Mechanical Surface Detection)
- Electronics: DAE4 Sn1303; Calibrated: 10.11.2011
- Phantom: SAM1; Type: QD000P40CD; Serial: TP:1670
- Measurement SW: DASY52, Version 52.8 (1); SEMCAD X Version 14.6.5 (6469)

Ch1/Area Scan (61x91x1): Measurement grid: dx=15mm, dy=15mm

Maximum value of SAR (interpolated) = 0.0638 mW/g

Ch1/Zoom Scan (5x5x7)/Cube 0: Measurement grid: dx=8mm, dy=8mm, dz=5mm

Reference Value = 4.452 V/m; Power Drift = 0.05 dB

Peak SAR (extrapolated) = 0.163 mW/g

SAR(1 g) = 0.063 mW/g; SAR(10 g) = 0.031 mW/g

Maximum value of SAR (measured) = 0.0665 mW/g

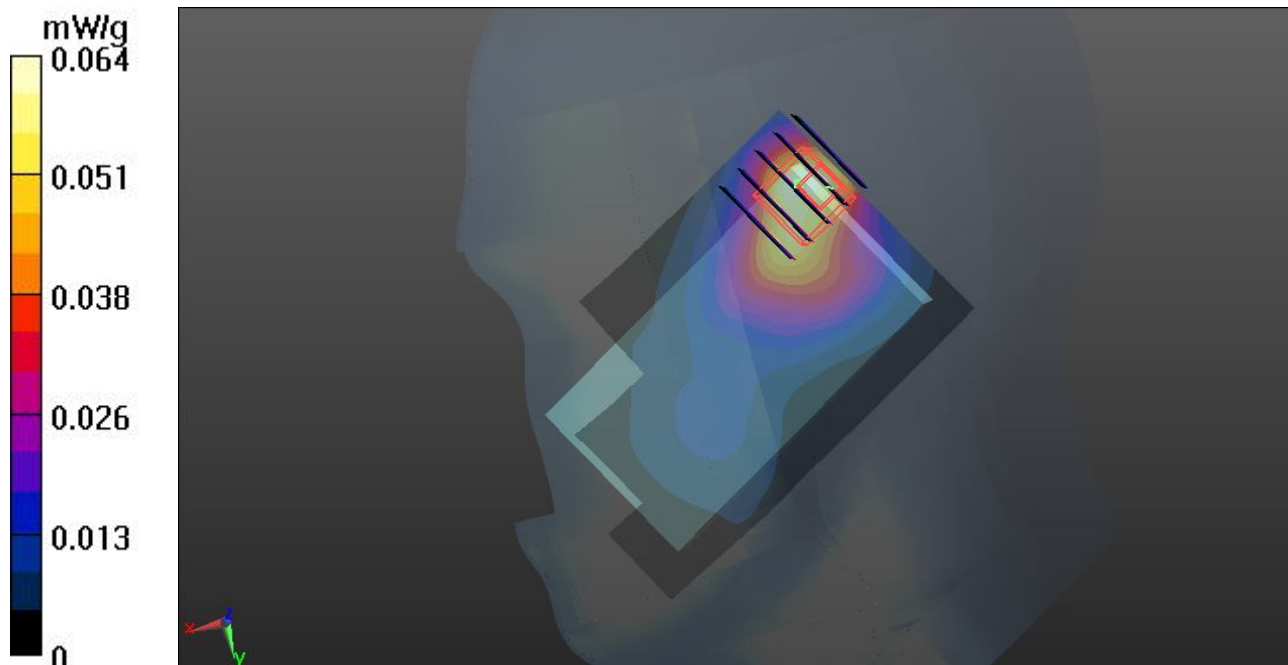

66 802.11b_Left Cheek_Ch1

DUT: 251703

Communication System: WIFI; Frequency: 2412 MHz; Duty Cycle: 1:1

Medium: HSL_2450_120723 Medium parameters used: $f = 2412$ MHz; $\sigma = 1.791$ mho/m; $\epsilon_r =$

39.777 ; $\rho = 1000$ kg/m³

Ambient Temperature : 23.3 °C ; Liquid Temperature : 21.3 °C

DASY5 Configuration:

- Probe: ES3DV3 - SN3270; ConvF(4.52, 4.52, 4.52); Calibrated: 12.09.2011;
- Sensor-Surface: 4mm (Mechanical Surface Detection)
- Electronics: DAE4 Sn1303; Calibrated: 10.11.2011
- Phantom: SAM1; Type: QD000P40CD; Serial: TP:1670
- Measurement SW: DASY52, Version 52.8 (1); SEMCAD X Version 14.6.5 (6469)

Ch1/Area Scan (61x91x1): Measurement grid: dx=15mm, dy=15mm

Maximum value of SAR (interpolated) = 0.0683 mW/g

Ch1/Zoom Scan (5x5x7)/Cube 0: Measurement grid: dx=8mm, dy=8mm, dz=5mm

Reference Value = 4.376 V/m; Power Drift = -0.09 dB

Peak SAR (extrapolated) = 0.103 mW/g

SAR(1 g) = 0.059 mW/g; SAR(10 g) = 0.034 mW/g

Maximum value of SAR (measured) = 0.0634 mW/g

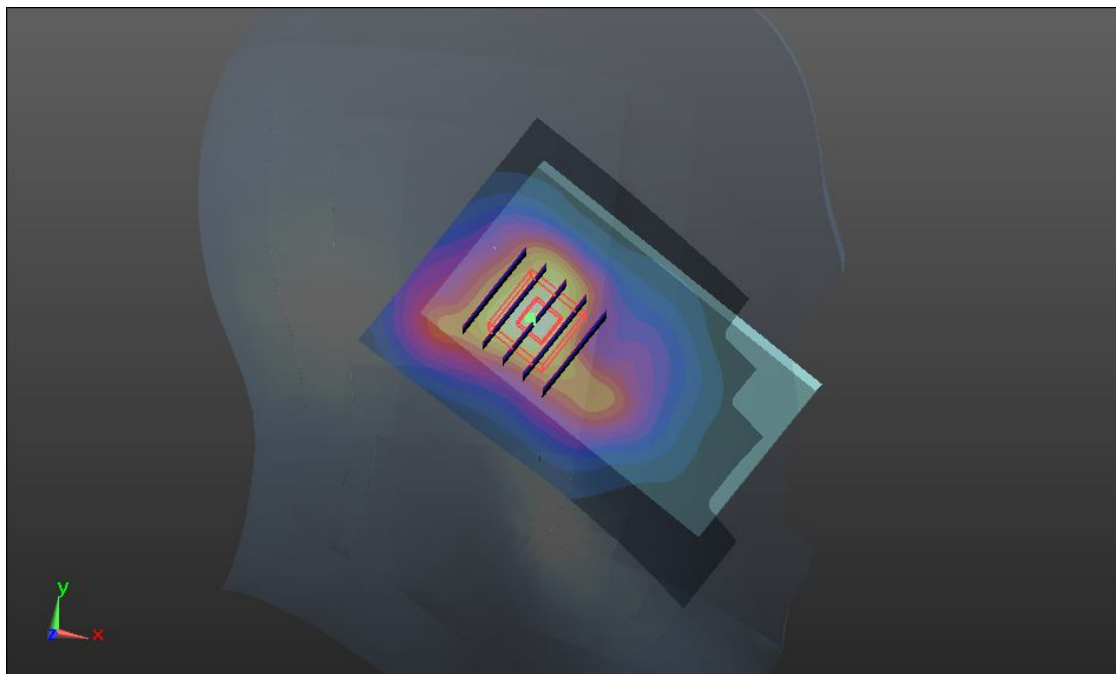
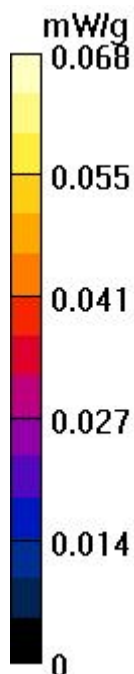

67 802.11b_Left Tilted_Ch1

DUT: 251703

Communication System: WIFI; Frequency: 2412 MHz; Duty Cycle: 1:1

Medium: HSL_2450_120723 Medium parameters used: $f = 2412 \text{ MHz}$; $\sigma = 1.791 \text{ mho/m}$; $\epsilon_r =$

39.777 ; $\rho = 1000 \text{ kg/m}^3$

Ambient Temperature : $23.3 \text{ }^\circ\text{C}$; Liquid Temperature : $21.3 \text{ }^\circ\text{C}$

DASY5 Configuration:

- Probe: ES3DV3 - SN3270; ConvF(4.52, 4.52, 4.52); Calibrated: 12.09.2011;
- Sensor-Surface: 4mm (Mechanical Surface Detection)
- Electronics: DAE4 Sn1303; Calibrated: 10.11.2011
- Phantom: SAM1; Type: QD000P40CD; Serial: TP:1670
- Measurement SW: DASY52, Version 52.8 (1); SEMCAD X Version 14.6.5 (6469)

Ch1/Area Scan (61x91x1): Measurement grid: $dx=15\text{mm}$, $dy=15\text{mm}$

Maximum value of SAR (interpolated) = 0.0409 mW/g

Ch1/Zoom Scan (5x5x7)/Cube 0: Measurement grid: $dx=8\text{mm}$, $dy=8\text{mm}$, $dz=5\text{mm}$

Reference Value = 4.089 V/m ; Power Drift = 0.16 dB

Peak SAR (extrapolated) = 0.066 mW/g

SAR(1 g) = 0.037 mW/g ; SAR(10 g) = 0.020 mW/g

Maximum value of SAR (measured) = 0.0395 mW/g

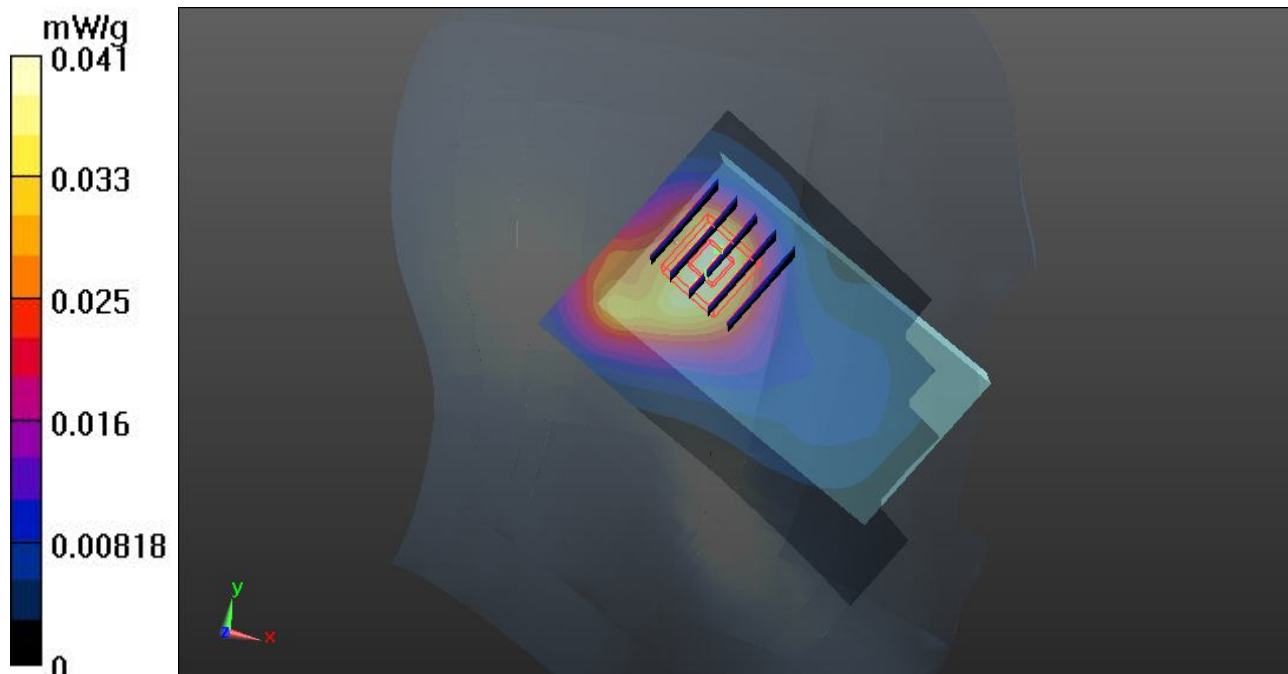

37 GSM850_GPRS12_Front_1cm_Ch128

DUT: 251703

Communication System: GPRS/EDGE12; Frequency: 824.2 MHz; Duty Cycle: 1:2
 Medium: MSL_835_120806 Medium parameters used: $f = 824.2 \text{ MHz}$; $\sigma = 0.966 \text{ mho/m}$; $\epsilon_r = 54.465$; $\rho = 1000 \text{ kg/m}^3$
 Ambient Temperature : $23.7 \text{ }^\circ\text{C}$; Liquid Temperature : $21.4 \text{ }^\circ\text{C}$

DASY5 Configuration:

- Probe: ES3DV3 - SN3270; ConvF(6.16, 6.16, 6.16); Calibrated: 12.09.2011;
- Sensor-Surface: 4mm (Mechanical Surface Detection)
- Electronics: DAE4 Sn1303; Calibrated: 10.11.2011
- Phantom: SAM1; Type: QD000P40CD; Serial: TP:1670
- Measurement SW: DASY52, Version 52.8 (1); SEMCAD X Version 14.6.5 (6469)

Ch128/Area Scan (61x91x1): Measurement grid: $dx=15\text{mm}$, $dy=15\text{mm}$
 Maximum value of SAR (interpolated) = 1.11 mW/g

Ch128/Zoom Scan (5x5x7)/Cube 0: Measurement grid: $dx=8\text{mm}$, $dy=8\text{mm}$, $dz=5\text{mm}$
 Reference Value = 31.818 V/m ; Power Drift = 0.08 dB
 Peak SAR (extrapolated) = 1.368 mW/g
SAR(1 g) = 1.050 mW/g ; SAR(10 g) = 0.781 mW/g
 Maximum value of SAR (measured) = 1.11 mW/g

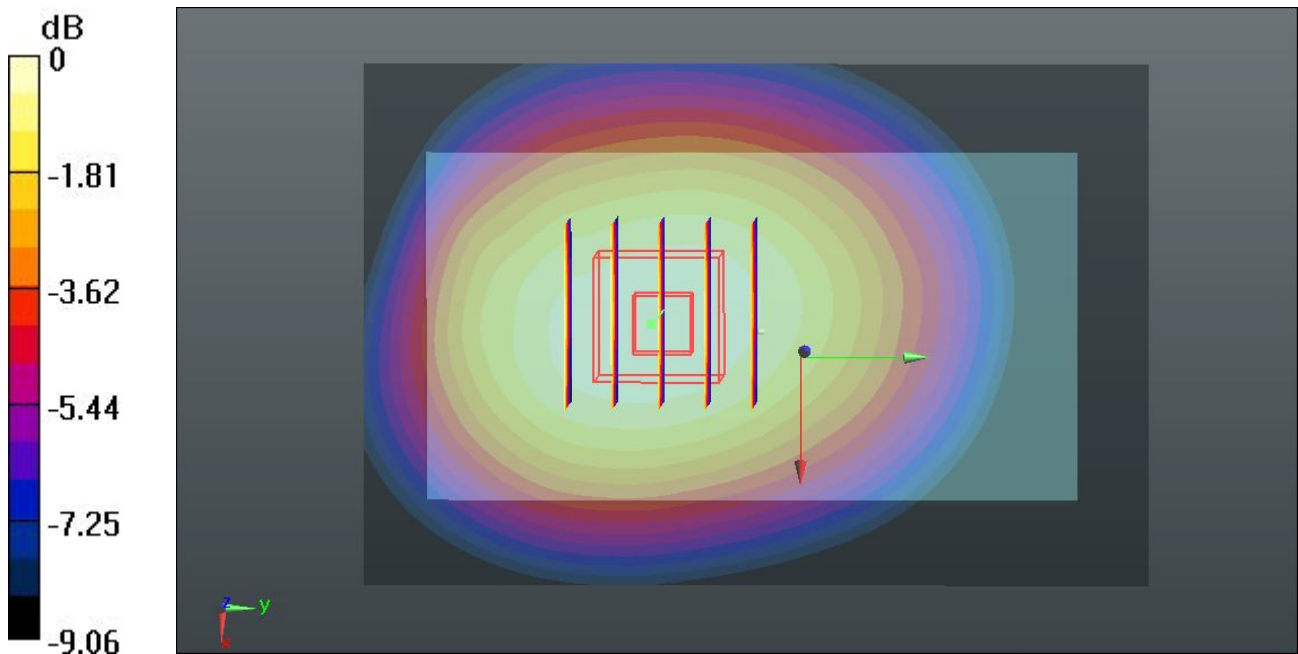

0 dB = 1.11 mW/g = 0.91 dB mW/g

38 GSM850_GPRS12_Back_1cm_Ch128

DUT: 251703

Communication System: GPRS/EDGE12; Frequency: 824.2 MHz; Duty Cycle: 1:2
Medium: MSL_835_120806 Medium parameters used: $f = 824.2$ MHz; $\sigma = 0.966$ mho/m; $\epsilon_r = 54.465$; $\rho = 1000$ kg/m³
Ambient Temperature : 23.7 °C ; Liquid Temperature : 21.4 °C

DASY5 Configuration:

- Probe: ES3DV3 - SN3270; ConvF(6.16, 6.16, 6.16); Calibrated: 12.09.2011;
- Sensor-Surface: 4mm (Mechanical Surface Detection)
- Electronics: DAE4 Sn1303; Calibrated: 10.11.2011
- Phantom: SAM1; Type: QD000P40CD; Serial: TP:1670
- Measurement SW: DASY52, Version 52.8 (1); SEMCAD X Version 14.6.5 (6469)

Ch128/Area Scan (61x91x1): Measurement grid: dx=15mm, dy=15mm
Maximum value of SAR (interpolated) = 1.34 mW/g

Ch128/Zoom Scan (5x5x7)/Cube 0: Measurement grid: dx=8mm, dy=8mm, dz=5mm
Reference Value = 34.261 V/m; Power Drift = 0.01 dB
Peak SAR (extrapolated) = 1.719 mW/g
SAR(1 g) = 1.280 mW/g; SAR(10 g) = 0.934 mW/g
Maximum value of SAR (measured) = 1.36 mW/g

Ch128/Zoom Scan (5x5x7)/Cube 1: Measurement grid: dx=8mm, dy=8mm, dz=5mm
Reference Value = 34.261 V/m; Power Drift = 0.01 dB
Peak SAR (extrapolated) = 1.600 mW/g
SAR(1 g) = 1.140 mW/g; SAR(10 g) = 0.798 mW/g
Maximum value of SAR (measured) = 1.27 mW/g

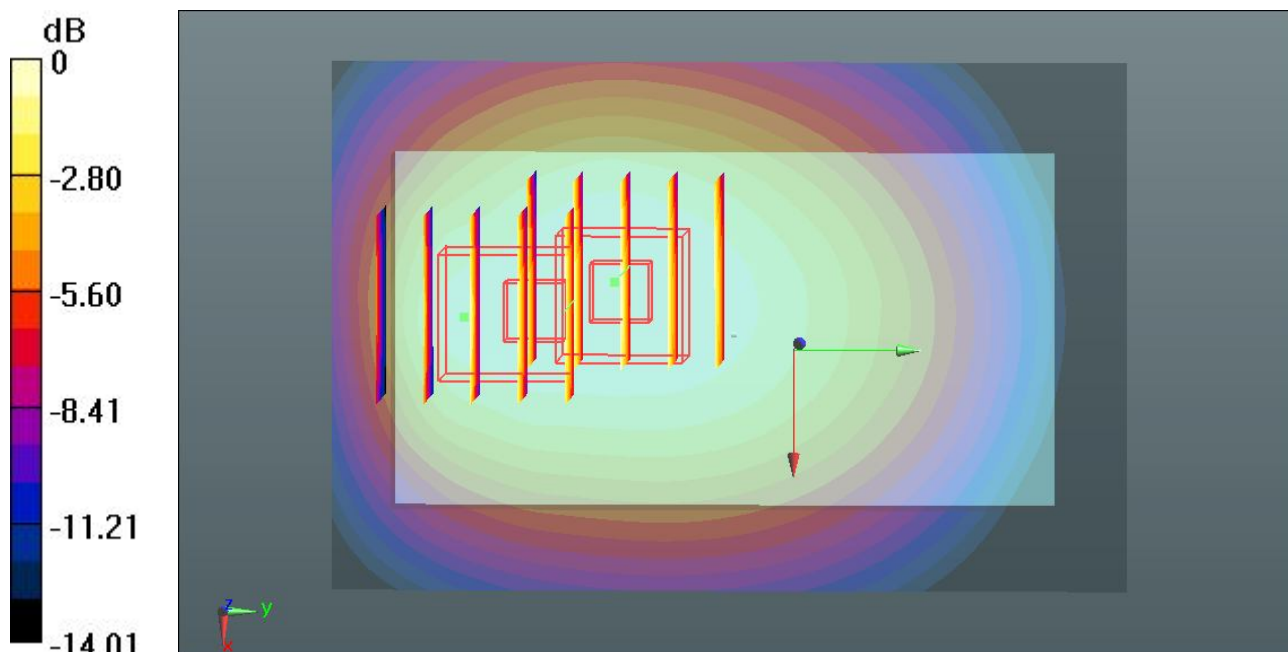

0 dB = 1.27 mW/g = 2.08 dB mW/g

39 GSM850_GPRS12_Left Side_1cm_Ch128

DUT: 251703

Communication System: GPRS/EDGE12; Frequency: 824.2 MHz; Duty Cycle: 1:2
 Medium: MSL_835_120806 Medium parameters used: $f = 824.2 \text{ MHz}$; $\sigma = 0.966 \text{ mho/m}$; $\epsilon_r = 54.465$; $\rho = 1000 \text{ kg/m}^3$
 Ambient Temperature : $23.7 \text{ }^\circ\text{C}$; Liquid Temperature : $21.4 \text{ }^\circ\text{C}$

DASY5 Configuration:

- Probe: ES3DV3 - SN3270; ConvF(6.16, 6.16, 6.16); Calibrated: 12.09.2011;
- Sensor-Surface: 4mm (Mechanical Surface Detection)
- Electronics: DAE4 Sn1303; Calibrated: 10.11.2011
- Phantom: SAM1; Type: QD000P40CD; Serial: TP:1670
- Measurement SW: DASY52, Version 52.8 (1); SEMCAD X Version 14.6.5 (6469)

Ch128/Area Scan (41x91x1): Measurement grid: $dx=15\text{mm}$, $dy=15\text{mm}$
 Maximum value of SAR (interpolated) = 0.955 mW/g

Ch128/Zoom Scan (5x5x7)/Cube 0: Measurement grid: $dx=8\text{mm}$, $dy=8\text{mm}$, $dz=5\text{mm}$
 Reference Value = 30.907 V/m ; Power Drift = 0.03 dB
 Peak SAR (extrapolated) = 1.272 mW/g
SAR(1 g) = 0.899 mW/g ; SAR(10 g) = 0.624 mW/g
 Maximum value of SAR (measured) = 0.958 mW/g

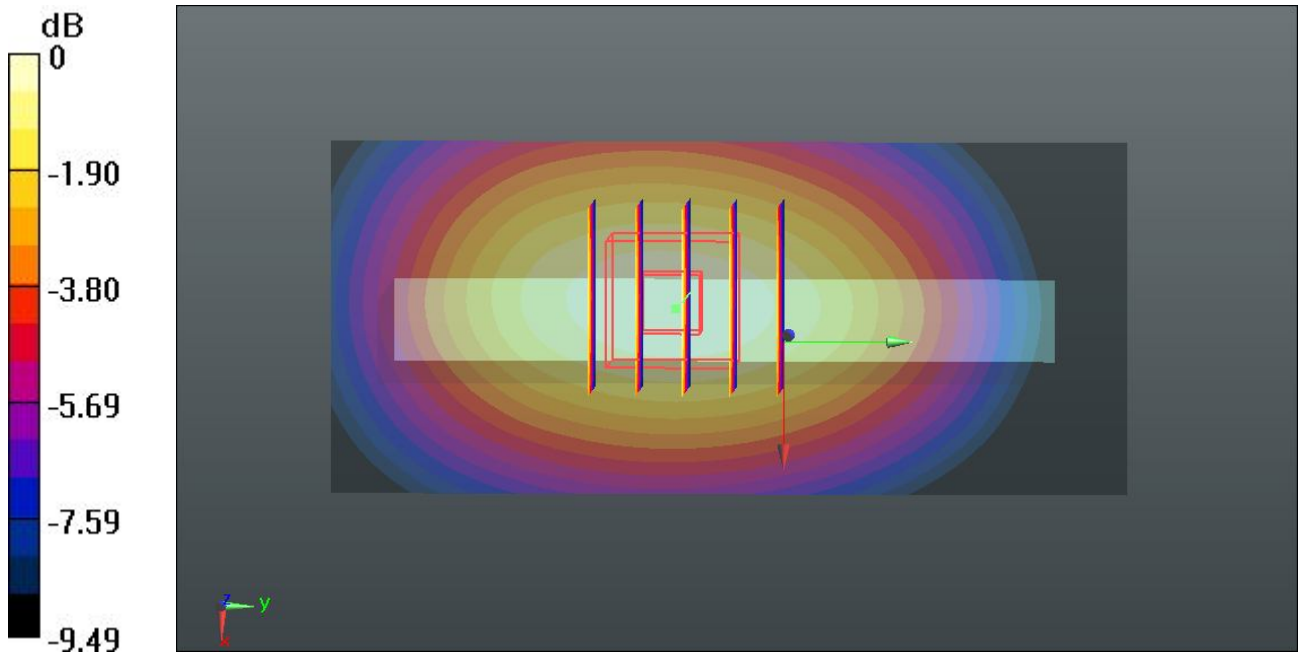

$0 \text{ dB} = 0.958 \text{ mW/g} = -0.37 \text{ dB mW/g}$

40 GSM850_GPRS12_Right Side_1cm_Ch128

DUT: 251703

Communication System: GPRS/EDGE12; Frequency: 824.2 MHz; Duty Cycle: 1:2
 Medium: MSL_835_120806 Medium parameters used: $f = 824.2 \text{ MHz}$; $\sigma = 0.966 \text{ mho/m}$; $\epsilon_r = 54.465$; $\rho = 1000 \text{ kg/m}^3$
 Ambient Temperature : $23.7 \text{ }^\circ\text{C}$; Liquid Temperature : $21.4 \text{ }^\circ\text{C}$

DASY5 Configuration:

- Probe: ES3DV3 - SN3270; ConvF(6.16, 6.16, 6.16); Calibrated: 12.09.2011;
- Sensor-Surface: 4mm (Mechanical Surface Detection)
- Electronics: DAE4 Sn1303; Calibrated: 10.11.2011
- Phantom: SAM1; Type: QD000P40CD; Serial: TP:1670
- Measurement SW: DASY52, Version 52.8 (1); SEMCAD X Version 14.6.5 (6469)

Ch128/Area Scan (41x91x1): Measurement grid: $dx=15\text{mm}$, $dy=15\text{mm}$
 Maximum value of SAR (interpolated) = 0.864 mW/g

Ch128/Zoom Scan (5x5x7)/Cube 0: Measurement grid: $dx=8\text{mm}$, $dy=8\text{mm}$, $dz=5\text{mm}$
 Reference Value = 28.743 V/m ; Power Drift = 0.03 dB
 Peak SAR (extrapolated) = 1.162 mW/g
SAR(1 g) = 0.812 mW/g ; SAR(10 g) = 0.556 mW/g
 Maximum value of SAR (measured) = 0.863 mW/g

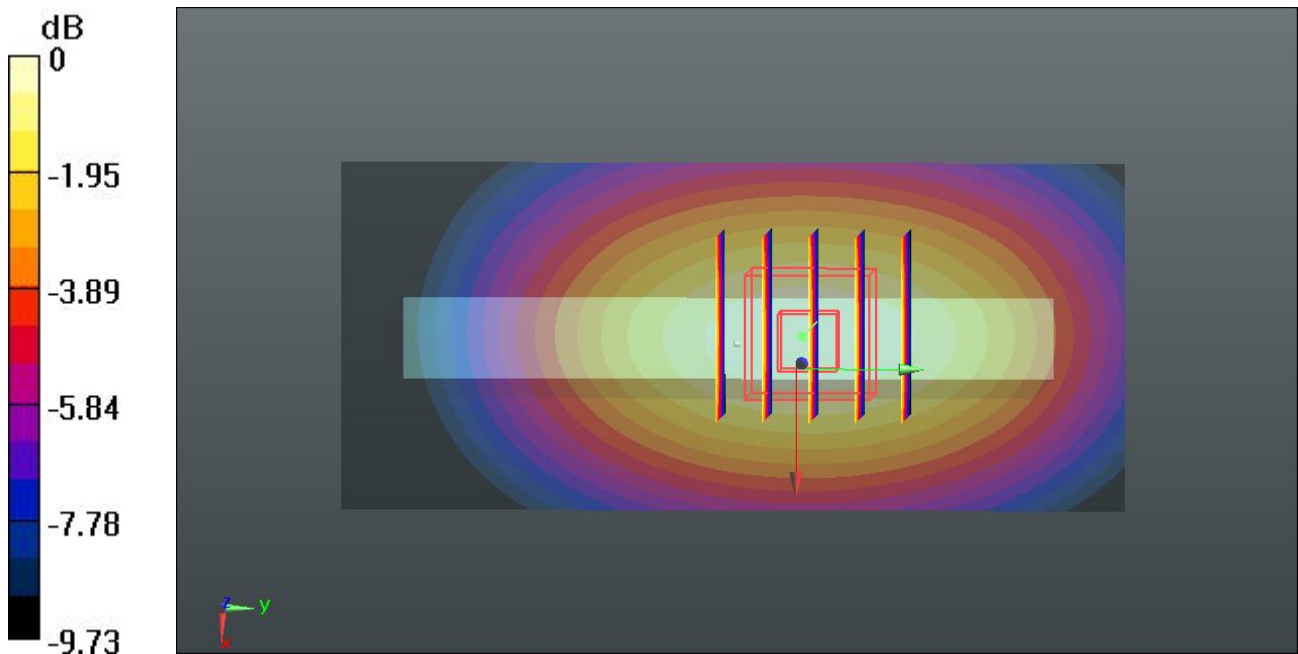

$0 \text{ dB} = 0.863 \text{ mW/g} = -1.28 \text{ dB mW/g}$

41 GSM850_GPRS12_Bottom Side_1cm_Ch128

DUT: 251703

Communication System: GPRS/EDGE12; Frequency: 824.2 MHz; Duty Cycle: 1:2
 Medium: MSL_835_120806 Medium parameters used: $f = 824.2 \text{ MHz}$; $\sigma = 0.966 \text{ mho/m}$; $\epsilon_r = 54.465$; $\rho = 1000 \text{ kg/m}^3$
 Ambient Temperature : $23.7 \text{ }^\circ\text{C}$; Liquid Temperature : $21.4 \text{ }^\circ\text{C}$

DASY5 Configuration:

- Probe: ES3DV3 - SN3270; ConvF(6.16, 6.16, 6.16); Calibrated: 12.09.2011;
- Sensor-Surface: 4mm (Mechanical Surface Detection)
- Electronics: DAE4 Sn1303; Calibrated: 10.11.2011
- Phantom: SAM1; Type: QD000P40CD; Serial: TP:1670
- Measurement SW: DASY52, Version 52.8 (1); SEMCAD X Version 14.6.5 (6469)

Ch128/Area Scan (41x61x1): Measurement grid: $dx=15\text{mm}$, $dy=15\text{mm}$
 Maximum value of SAR (interpolated) = 0.106 mW/g

Ch128/Zoom Scan (5x5x7)/Cube 0: Measurement grid: $dx=8\text{mm}$, $dy=8\text{mm}$, $dz=5\text{mm}$
 Reference Value = 8.985 V/m ; Power Drift = -0.07 dB
 Peak SAR (extrapolated) = 0.172 mW/g
SAR(1 g) = 0.099 mW/g ; SAR(10 g) = 0.064 mW/g
 Maximum value of SAR (measured) = 0.106 mW/g

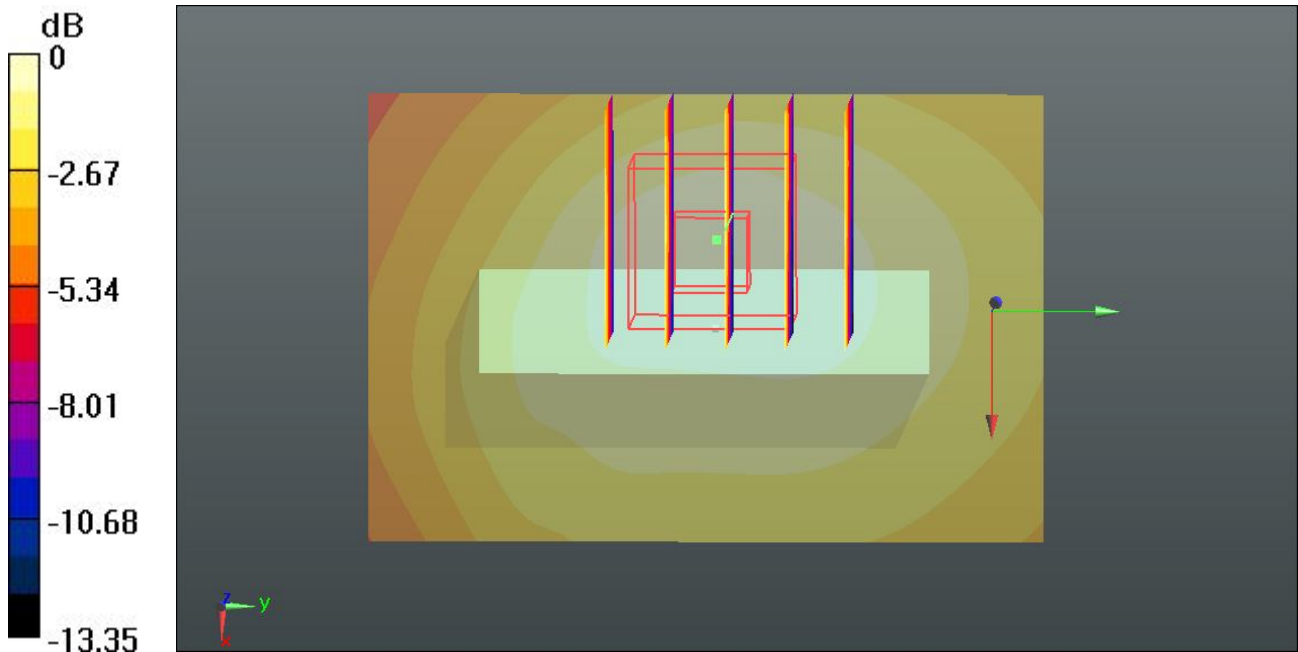

0 dB = 0.106 mW/g = -19.49 dB mW/g

42 GSM850_GPRS12_Front_1cm_Ch189

DUT: 251703

Communication System: GPRS/EDGE12; Frequency: 836.4 MHz; Duty Cycle: 1:2
 Medium: MSL_835_120806 Medium parameters used: $f = 836.4 \text{ MHz}$; $\sigma = 0.978 \text{ mho/m}$; $\epsilon_r = 54.378$; $\rho = 1000 \text{ kg/m}^3$
 Ambient Temperature : $23.7 \text{ }^\circ\text{C}$; Liquid Temperature : $21.4 \text{ }^\circ\text{C}$

DASY5 Configuration:

- Probe: ES3DV3 - SN3270; ConvF(6.16, 6.16, 6.16); Calibrated: 12.09.2011;
- Sensor-Surface: 4mm (Mechanical Surface Detection)
- Electronics: DAE4 Sn1303; Calibrated: 10.11.2011
- Phantom: SAM1; Type: QD000P40CD; Serial: TP:1670
- Measurement SW: DASY52, Version 52.8 (1); SEMCAD X Version 14.6.5 (6469)

Ch189/Area Scan (61x91x1): Measurement grid: $dx=15\text{mm}$, $dy=15\text{mm}$
 Maximum value of SAR (interpolated) = 1.18 mW/g

Ch189/Zoom Scan (5x5x7)/Cube 0: Measurement grid: $dx=8\text{mm}$, $dy=8\text{mm}$, $dz=5\text{mm}$
 Reference Value = 33.160 V/m ; Power Drift = 0.03 dB
 Peak SAR (extrapolated) = 1.449 mW/g
SAR(1 g) = 1.110 mW/g ; SAR(10 g) = 0.823 mW/g
 Maximum value of SAR (measured) = 1.17 mW/g

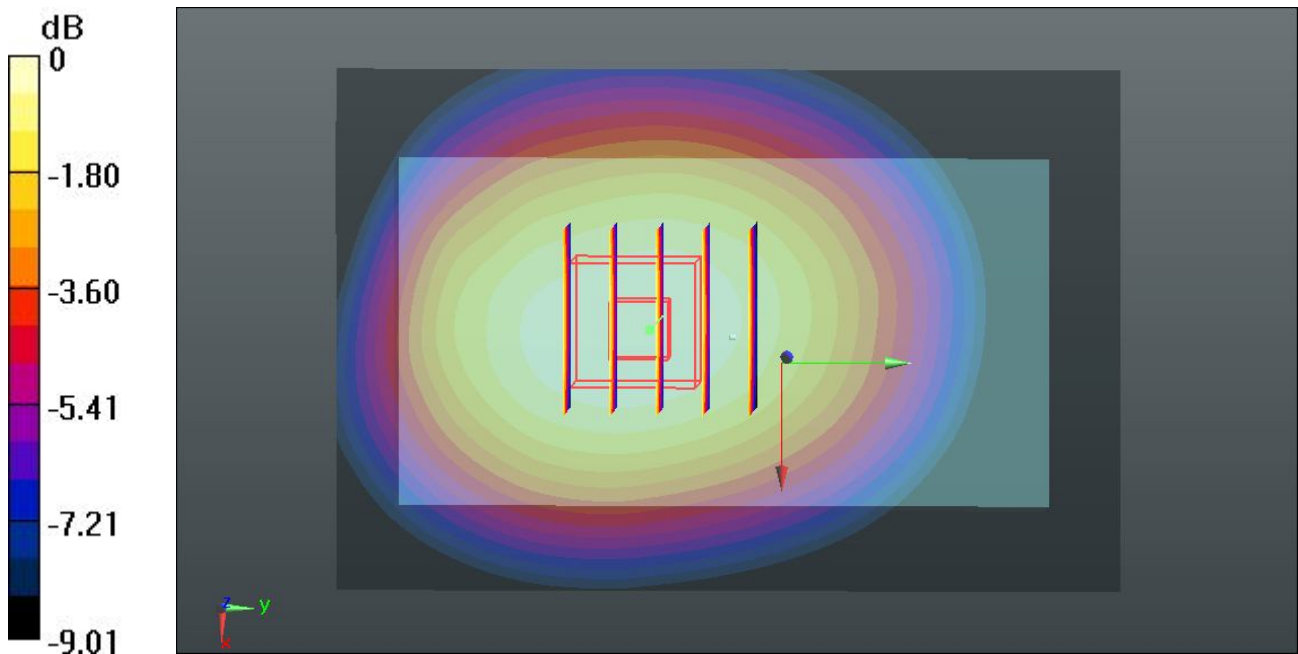

0 dB = $1.17 \text{ mW/g} = 1.36 \text{ dB mW/g}$

43 GSM850_GPRS12_Front_1cm_Ch251

DUT: 251703

Communication System: GPRS/EDGE12; Frequency: 848.8 MHz; Duty Cycle: 1:2

Medium: MSL_835_120806 Medium parameters used: $f = 849$ MHz; $\sigma = 0.989$ mho/m; $\epsilon_r = 54.268$;

$\rho = 1000$ kg/m³

Ambient Temperature : 23.7 °C ; Liquid Temperature : 21.4 °C

DASY5 Configuration:

- Probe: ES3DV3 - SN3270; ConvF(6.16, 6.16, 6.16); Calibrated: 12.09.2011;
- Sensor-Surface: 4mm (Mechanical Surface Detection)
- Electronics: DAE4 Sn1303; Calibrated: 10.11.2011
- Phantom: SAM1; Type: QD000P40CD; Serial: TP:1670
- Measurement SW: DASY52, Version 52.8 (1); SEMCAD X Version 14.6.5 (6469)

Ch251/Area Scan (61x91x1): Measurement grid: dx=15mm, dy=15mm

Maximum value of SAR (interpolated) = 1.27 mW/g

Ch251/Zoom Scan (5x5x7)/Cube 0: Measurement grid: dx=8mm, dy=8mm, dz=5mm

Reference Value = 34.259 V/m; Power Drift = 0.09 dB

Peak SAR (extrapolated) = 1.592 mW/g

SAR(1 g) = 1.220 mW/g; SAR(10 g) = 0.896 mW/g

Maximum value of SAR (measured) = 1.27 mW/g

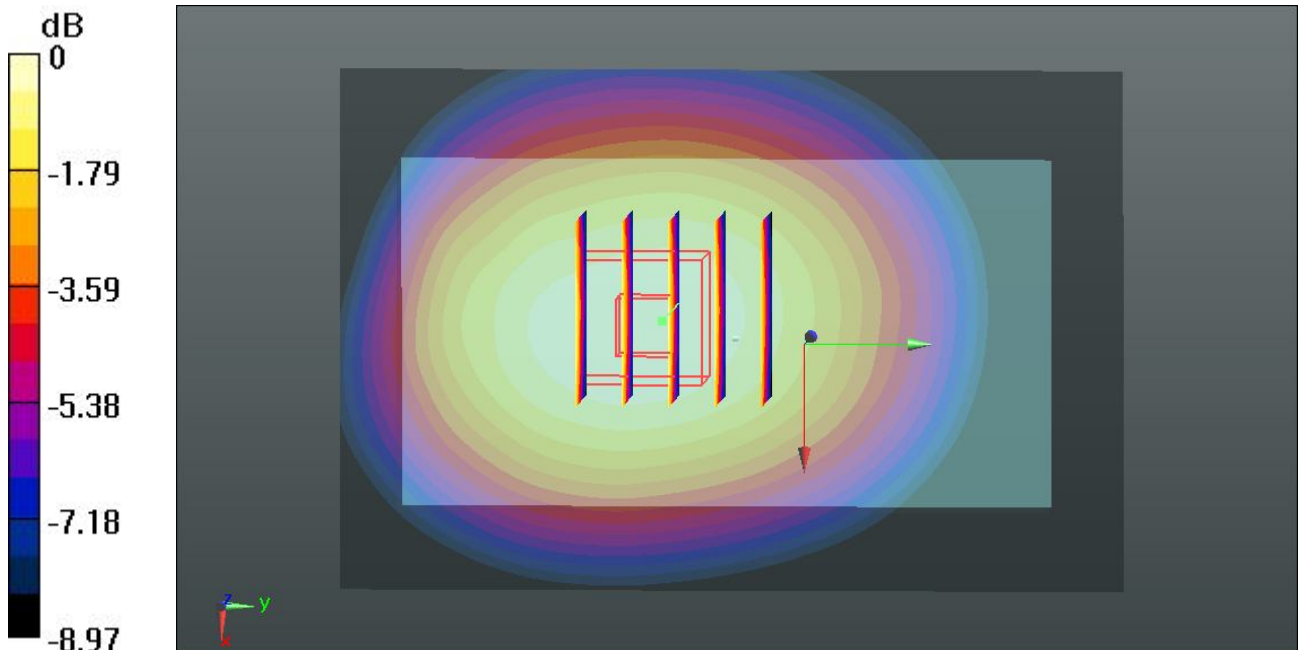

0 dB = 1.27 mW/g = 2.08 dB mW/g

44 GSM850_GPRS12_Back_1cm_Ch189

DUT: 251703

Communication System: GPRS/EDGE12; Frequency: 836.4 MHz; Duty Cycle: 1:2
Medium: MSL_835_120806 Medium parameters used: $f = 836.4 \text{ MHz}$; $\sigma = 0.978 \text{ mho/m}$; $\epsilon_r = 54.378$; $\rho = 1000 \text{ kg/m}^3$
Ambient Temperature : $23.7 \text{ }^\circ\text{C}$; Liquid Temperature : $21.4 \text{ }^\circ\text{C}$

DASY5 Configuration:

- Probe: ES3DV3 - SN3270; ConvF(6.16, 6.16, 6.16); Calibrated: 12.09.2011;
- Sensor-Surface: 4mm (Mechanical Surface Detection)
- Electronics: DAE4 Sn1303; Calibrated: 10.11.2011
- Phantom: SAM1; Type: QD000P40CD; Serial: TP:1670
- Measurement SW: DASY52, Version 52.8 (1); SEMCAD X Version 14.6.5 (6469)

Ch189/Area Scan (61x91x1): Measurement grid: $dx=15\text{mm}$, $dy=15\text{mm}$
Maximum value of SAR (interpolated) = 1.41 mW/g

Ch189/Zoom Scan (5x5x7)/Cube 0: Measurement grid: $dx=8\text{mm}$, $dy=8\text{mm}$, $dz=5\text{mm}$
Reference Value = 34.782 V/m ; Power Drift = 0.05 dB
Peak SAR (extrapolated) = 1.776 mW/g
SAR(1 g) = 1.330 mW/g ; SAR(10 g) = 0.971 mW/g
Maximum value of SAR (measured) = 1.40 mW/g

Ch189/Zoom Scan (5x5x7)/Cube 1: Measurement grid: $dx=8\text{mm}$, $dy=8\text{mm}$, $dz=5\text{mm}$
Reference Value = 34.782 V/m ; Power Drift = 0.05 dB
Peak SAR (extrapolated) = 1.690 mW/g
SAR(1 g) = 1.200 mW/g ; SAR(10 g) = 0.830 mW/g
Maximum value of SAR (measured) = 1.33 mW/g

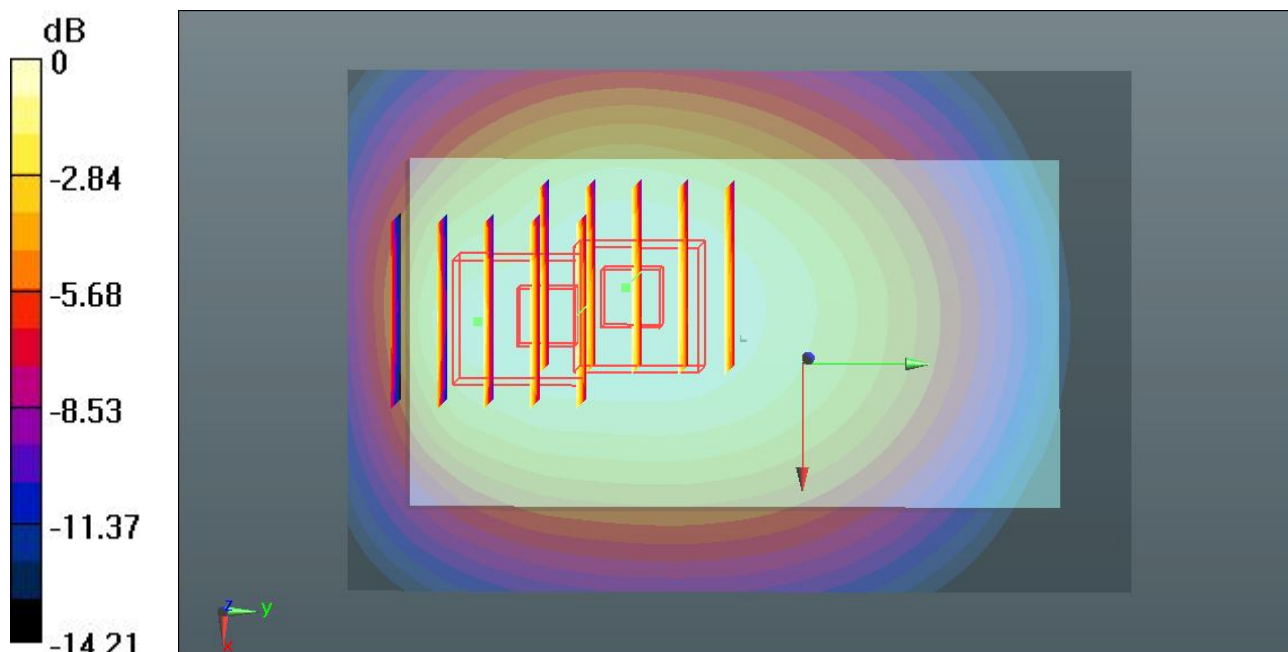

0 dB = $1.33 \text{ mW/g} = 2.48 \text{ dB mW/g}$

45 GSM850_GPRS12_Back_1cm_Ch251

DUT: 251703

Communication System: GPRS/EDGE12; Frequency: 848.8 MHz; Duty Cycle: 1:2

Medium: MSL_835_120806 Medium parameters used: $f = 849$ MHz; $\sigma = 0.989$ mho/m; $\epsilon_r = 54.268$;

$\rho = 1000$ kg/m³

Ambient Temperature : 23.7 °C ; Liquid Temperature : 21.4 °C

DASY5 Configuration:

- Probe: ES3DV3 - SN3270; ConvF(6.16, 6.16, 6.16); Calibrated: 12.09.2011;
- Sensor-Surface: 4mm (Mechanical Surface Detection)
- Electronics: DAE4 Sn1303; Calibrated: 10.11.2011
- Phantom: SAM1; Type: QD000P40CD; Serial: TP:1670
- Measurement SW: DASY52, Version 52.8 (1); SEMCAD X Version 14.6.5 (6469)

Ch251/Area Scan (61x91x1): Measurement grid: dx=15mm, dy=15mm

Maximum value of SAR (interpolated) = 1.57 mW/g

Ch251/Zoom Scan (5x5x7)/Cube 0: Measurement grid: dx=8mm, dy=8mm, dz=5mm

Reference Value = 37.373 V/m; Power Drift = -0.14 dB

Peak SAR (extrapolated) = 1.976 mW/g

SAR(1 g) = 1.410 mW/g; SAR(10 g) = 1.07 mW/g

Maximum value of SAR (measured) = 1.55 mW/g

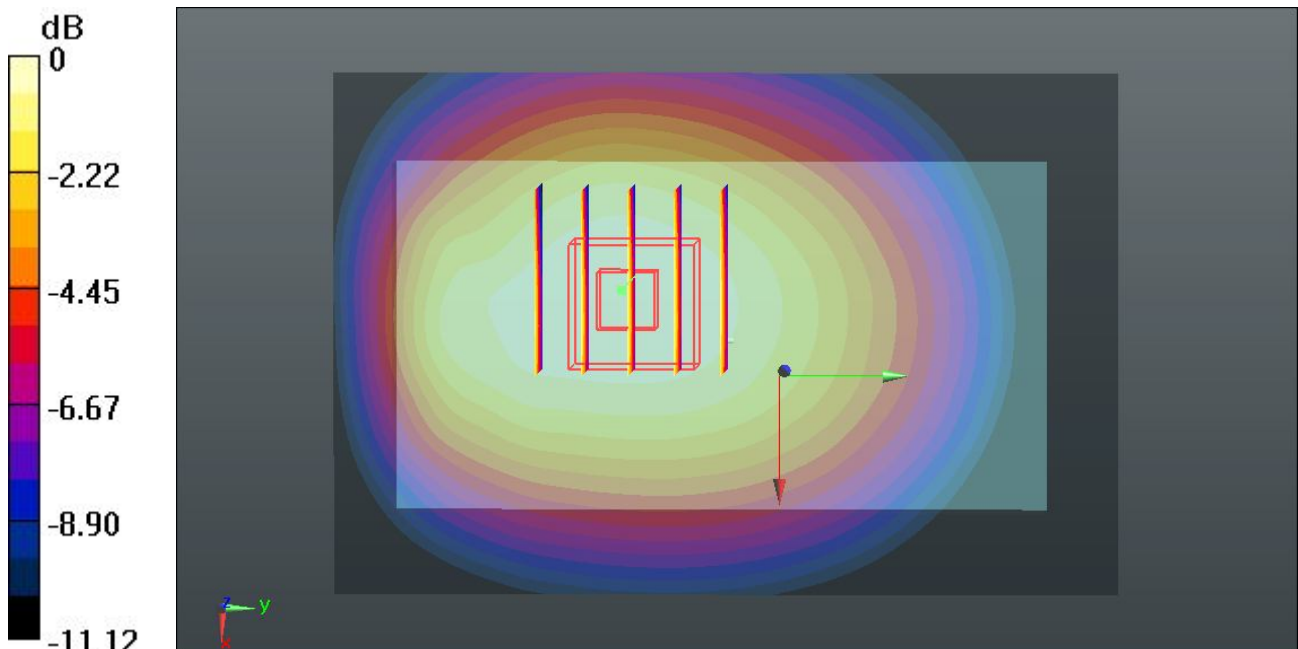

0 dB = 1.55 mW/g = 3.81 dB mW/g

45 GSM850_GPRS12_Back_1cm_Ch251_2D

DUT: 251703

Communication System: GPRS/EDGE12; Frequency: 848.8 MHz; Duty Cycle: 1:2

Medium: MSL_835_120806 Medium parameters used: $f = 849$ MHz; $\sigma = 0.989$ mho/m; $\epsilon_r = 54.268$;

$\rho = 1000$ kg/m³

Ambient Temperature : 23.7 °C ; Liquid Temperature : 21.4 °C

DASY5 Configuration:

- Probe: ES3DV3 - SN3270; ConvF(6.16, 6.16, 6.16); Calibrated: 12.09.2011;
- Sensor-Surface: 4mm (Mechanical Surface Detection)
- Electronics: DAE4 Sn1303; Calibrated: 10.11.2011
- Phantom: SAM1; Type: QD000P40CD; Serial: TP:1670
- Measurement SW: DASY52, Version 52.8 (1); SEMCAD X Version 14.6.5 (6469)

Ch251/Area Scan (61x91x1): Measurement grid: dx=15mm, dy=15mm

Maximum value of SAR (interpolated) = 1.57 mW/g

Ch251/Zoom Scan (5x5x7)/Cube 0: Measurement grid: dx=8mm, dy=8mm, dz=5mm

Reference Value = 37.373 V/m; Power Drift = -0.14 dB

Peak SAR (extrapolated) = 1.976 mW/g

SAR(1 g) = 1.410 mW/g; SAR(10 g) = 1.07 mW/g

Maximum value of SAR (measured) = 1.55 mW/g

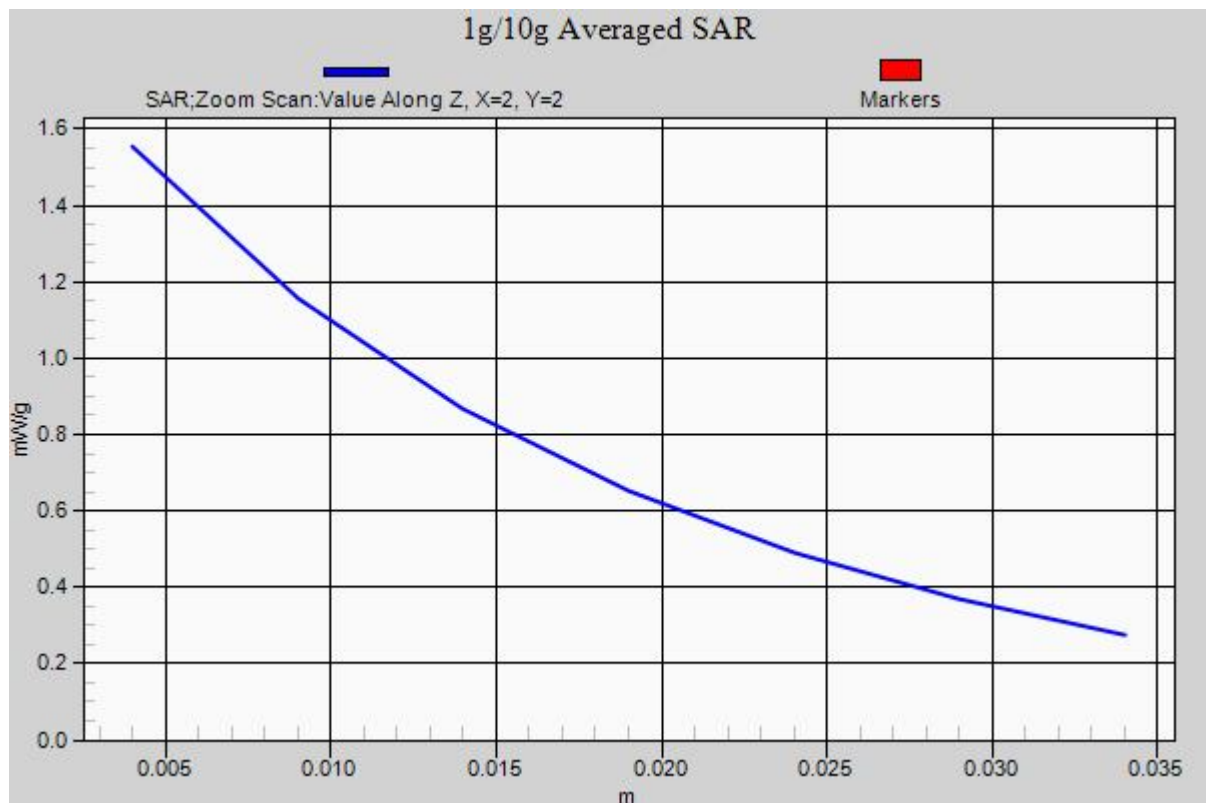

46 GSM850_GPRS12_Left Side_1cm_Ch189

DUT: 251703

Communication System: GPRS/EDGE12; Frequency: 836.4 MHz; Duty Cycle: 1:2
Medium: MSL_835_120806 Medium parameters used: $f = 836.4 \text{ MHz}$; $\sigma = 0.978 \text{ mho/m}$; $\epsilon_r = 54.378$; $\rho = 1000 \text{ kg/m}^3$
Ambient Temperature : $23.7 \text{ }^\circ\text{C}$; Liquid Temperature : $21.4 \text{ }^\circ\text{C}$

DASY5 Configuration:

- Probe: ES3DV3 - SN3270; ConvF(6.16, 6.16, 6.16); Calibrated: 12.09.2011;
- Sensor-Surface: 4mm (Mechanical Surface Detection)
- Electronics: DAE4 Sn1303; Calibrated: 10.11.2011
- Phantom: SAM1; Type: QD000P40CD; Serial: TP:1670
- Measurement SW: DASY52, Version 52.8 (1); SEMCAD X Version 14.6.5 (6469)

Ch189/Area Scan (41x91x1): Measurement grid: $dx=15\text{mm}$, $dy=15\text{mm}$

Maximum value of SAR (interpolated) = 1.00 mW/g

Ch189/Zoom Scan (5x5x7)/Cube 0: Measurement grid: $dx=8\text{mm}$, $dy=8\text{mm}$, $dz=5\text{mm}$

Reference Value = 31.431 V/m ; Power Drift = 0.03 dB

Peak SAR (extrapolated) = 1.320 mW/g

SAR(1 g) = 0.932 mW/g ; SAR(10 g) = 0.645 mW/g

Maximum value of SAR (measured) = 0.986 mW/g

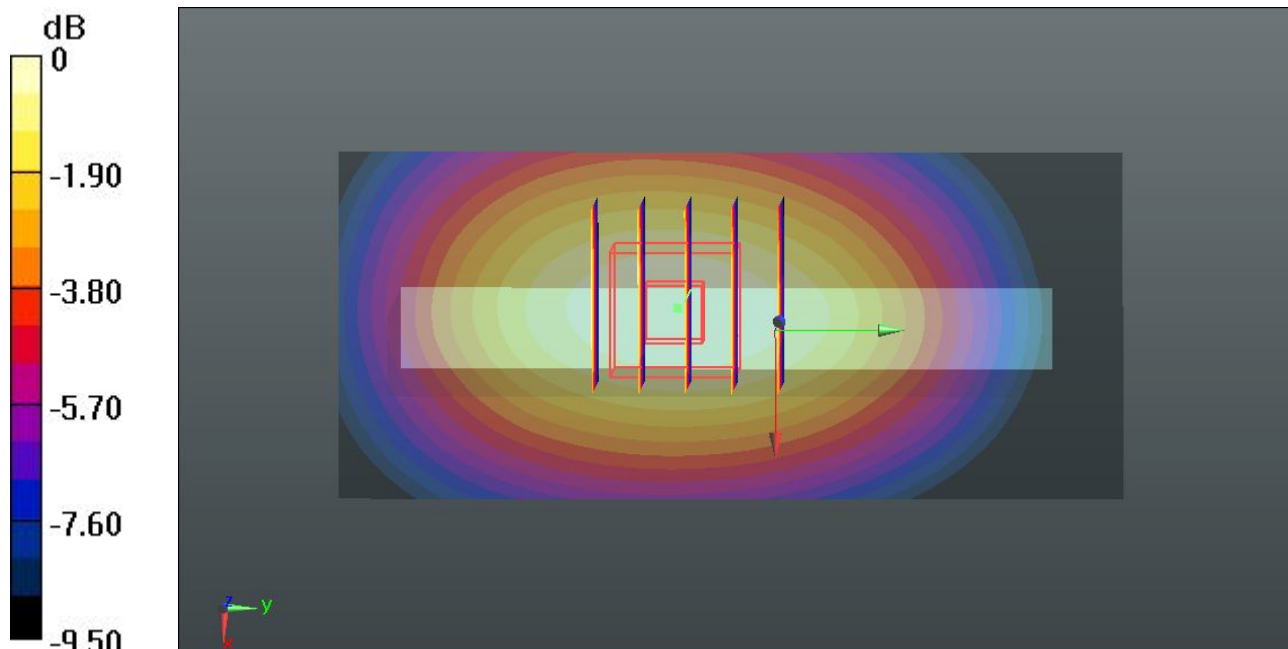

$0 \text{ dB} = 0.986 \text{ mW/g} = -0.12 \text{ dB mW/g}$

47 GSM850_GPRS12_Left Side_1cm_Ch251

DUT: 251703

Communication System: GPRS/EDGE12; Frequency: 848.8 MHz; Duty Cycle: 1:2

Medium: MSL_835_120806 Medium parameters used: $f = 849$ MHz; $\sigma = 0.989$ mho/m; $\epsilon_r = 54.268$;

$\rho = 1000$ kg/m³

Ambient Temperature : 23.7 °C ; Liquid Temperature : 21.4 °C

DASY5 Configuration:

- Probe: ES3DV3 - SN3270; ConvF(6.16, 6.16, 6.16); Calibrated: 12.09.2011;
- Sensor-Surface: 4mm (Mechanical Surface Detection)
- Electronics: DAE4 Sn1303; Calibrated: 10.11.2011
- Phantom: SAM1; Type: QD000P40CD; Serial: TP:1670
- Measurement SW: DASY52, Version 52.8 (1); SEMCAD X Version 14.6.5 (6469)

Ch251/Area Scan (41x91x1): Measurement grid: dx=15mm, dy=15mm

Maximum value of SAR (interpolated) = 1.05 mW/g

Ch251/Zoom Scan (5x5x7)/Cube 0: Measurement grid: dx=8mm, dy=8mm, dz=5mm

Reference Value = 32.406 V/m; Power Drift = -0.06 dB

Peak SAR (extrapolated) = 1.405 mW/g

SAR(1 g) = 0.988 mW/g; SAR(10 g) = 0.682 mW/g

Maximum value of SAR (measured) = 1.06 mW/g

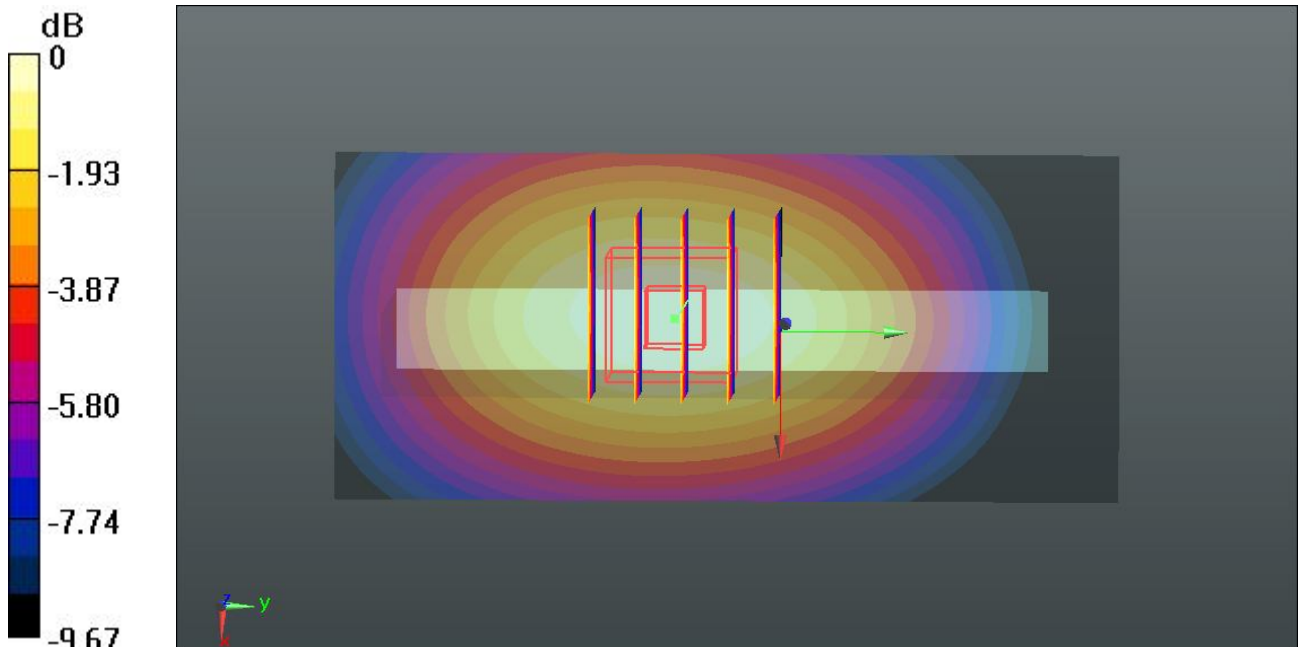

0 dB = 1.06 mW/g = 0.51 dB mW/g

48 GSM850_GPRS12_Right Side_1cm_Ch189

DUT: 251703

Communication System: GPRS/EDGE12; Frequency: 836.4 MHz; Duty Cycle: 1:2
 Medium: MSL_835_120806 Medium parameters used: $f = 836.4 \text{ MHz}$; $\sigma = 0.978 \text{ mho/m}$; $\epsilon_r = 54.378$; $\rho = 1000 \text{ kg/m}^3$
 Ambient Temperature : $23.7 \text{ }^\circ\text{C}$; Liquid Temperature : $21.4 \text{ }^\circ\text{C}$

DASY5 Configuration:

- Probe: ES3DV3 - SN3270; ConvF(6.16, 6.16, 6.16); Calibrated: 12.09.2011;
- Sensor-Surface: 4mm (Mechanical Surface Detection)
- Electronics: DAE4 Sn1303; Calibrated: 10.11.2011
- Phantom: SAM1; Type: QD000P40CD; Serial: TP:1670
- Measurement SW: DASY52, Version 52.8 (1); SEMCAD X Version 14.6.5 (6469)

Ch189/Area Scan (41x91x1): Measurement grid: $dx=15\text{mm}$, $dy=15\text{mm}$
 Maximum value of SAR (interpolated) = 0.915 mW/g

Ch189/Zoom Scan (5x5x7)/Cube 0: Measurement grid: $dx=8\text{mm}$, $dy=8\text{mm}$, $dz=5\text{mm}$
 Reference Value = 29.624 V/m ; Power Drift = -0.04 dB
 Peak SAR (extrapolated) = 1.220 mW/g
SAR(1 g) = 0.852 mW/g ; SAR(10 g) = 0.584 mW/g
 Maximum value of SAR (measured) = 0.903 mW/g

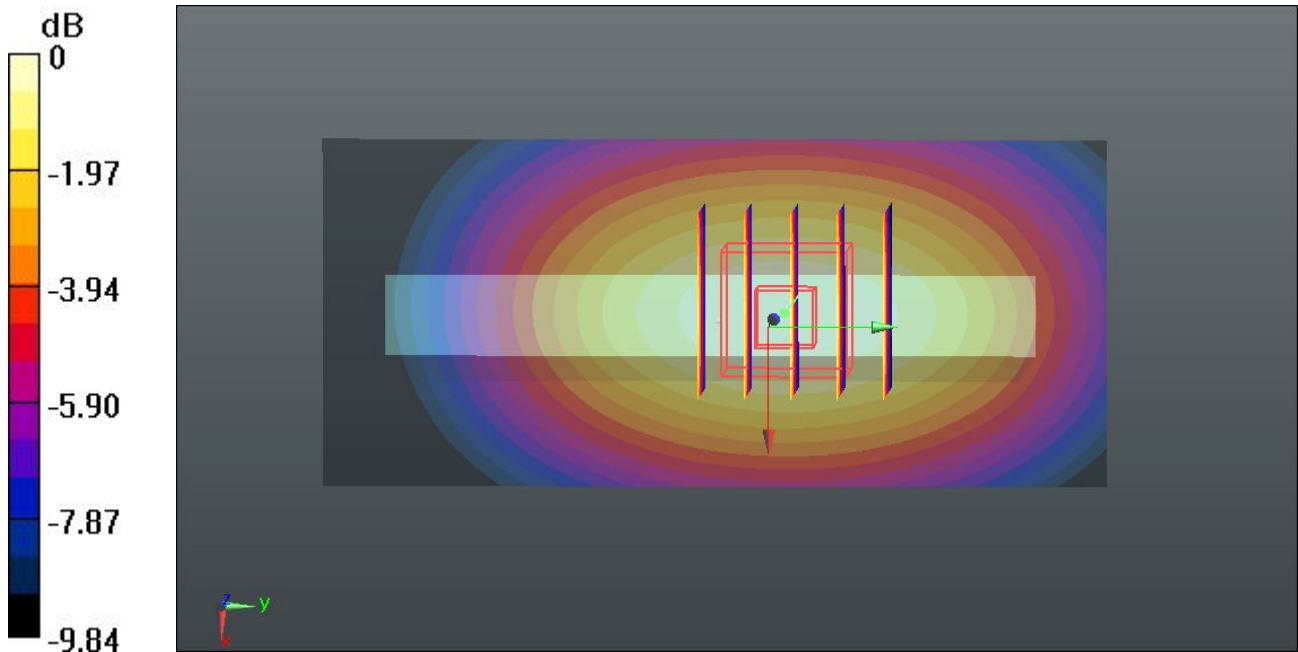

$0 \text{ dB} = 0.903 \text{ mW/g} = -0.89 \text{ dB mW/g}$

49 GSM850_GPRS12_Right Side_1cm_Ch251

DUT: 251703

Communication System: GPRS/EDGE12; Frequency: 848.8 MHz; Duty Cycle: 1:2

Medium: MSL_835_120806 Medium parameters used: $f = 849$ MHz; $\sigma = 0.989$ mho/m; $\epsilon_r = 54.268$;

$\rho = 1000$ kg/m³

Ambient Temperature : 23.7 °C ; Liquid Temperature : 21.4 °C

DASY5 Configuration:

- Probe: ES3DV3 - SN3270; ConvF(6.16, 6.16, 6.16); Calibrated: 12.09.2011;
- Sensor-Surface: 4mm (Mechanical Surface Detection)
- Electronics: DAE4 Sn1303; Calibrated: 10.11.2011
- Phantom: SAM1; Type: QD000P40CD; Serial: TP:1670
- Measurement SW: DASY52, Version 52.8 (1); SEMCAD X Version 14.6.5 (6469)

Ch251/Area Scan (41x91x1): Measurement grid: dx=15mm, dy=15mm

Maximum value of SAR (interpolated) = 0.989 mW/g

Ch251/Zoom Scan (5x5x7)/Cube 0: Measurement grid: dx=8mm, dy=8mm, dz=5mm

Reference Value = 30.766 V/m; Power Drift = 0.01 dB

Peak SAR (extrapolated) = 1.323 mW/g

SAR(1 g) = 0.920 mW/g; SAR(10 g) = 0.628 mW/g

Maximum value of SAR (measured) = 0.982 mW/g

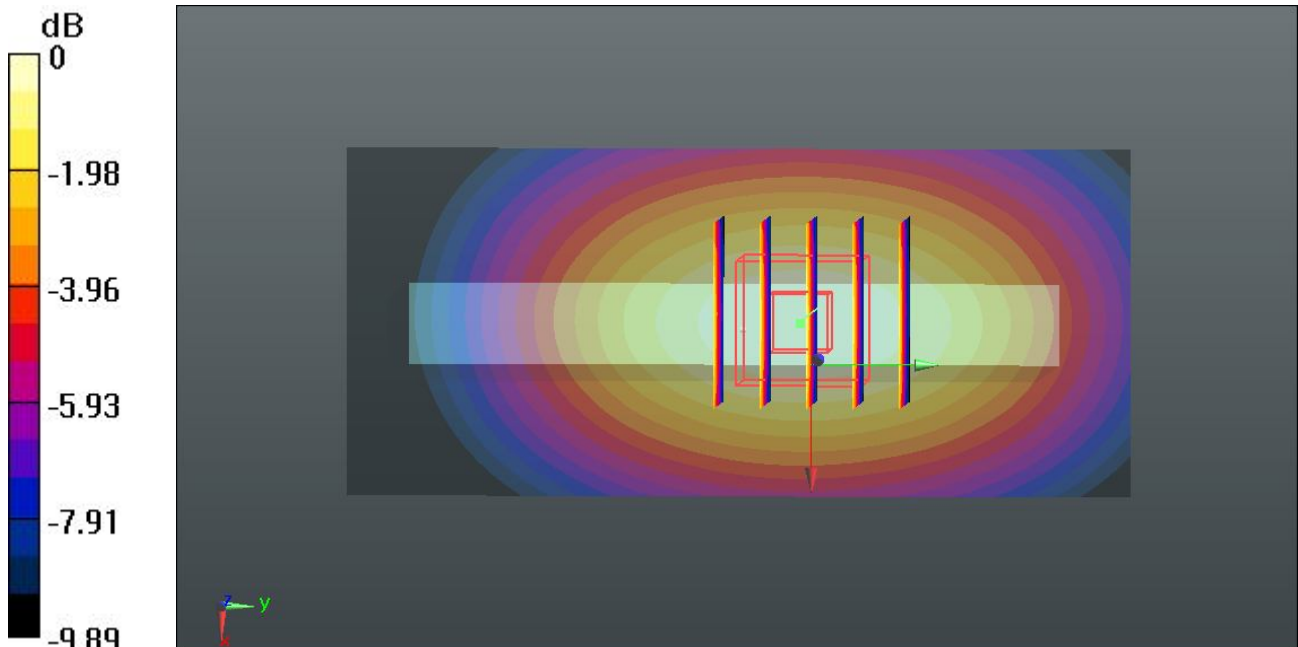

0 dB = 0.982 mW/g = -0.16 dB mW/g

50 GSM850_GPRS12_Back_1cm_Ch251_Headset

DUT: 251703

Communication System: GPRS/EDGE12; Frequency: 848.8 MHz; Duty Cycle: 1:2

Medium: MSL_835_120806 Medium parameters used: $f = 849$ MHz; $\sigma = 0.989$ mho/m; $\epsilon_r = 54.268$;

$\rho = 1000$ kg/m³

Ambient Temperature : 23.7 °C ; Liquid Temperature : 21.4 °C

DASY5 Configuration:

- Probe: ES3DV3 - SN3270; ConvF(6.16, 6.16, 6.16); Calibrated: 12.09.2011;
- Sensor-Surface: 4mm (Mechanical Surface Detection)
- Electronics: DAE4 Sn1303; Calibrated: 10.11.2011
- Phantom: SAM1; Type: QD000P40CD; Serial: TP:1670
- Measurement SW: DASY52, Version 52.8 (1); SEMCAD X Version 14.6.5 (6469)

Ch251/Area Scan (61x91x1): Measurement grid: dx=15mm, dy=15mm

Maximum value of SAR (interpolated) = 1.16 mW/g

Ch251/Zoom Scan (5x5x7)/Cube 0: Measurement grid: dx=8mm, dy=8mm, dz=5mm

Reference Value = 32.503 V/m; Power Drift = -0.08 dB

Peak SAR (extrapolated) = 1.469 mW/g

SAR(1 g) = 1.110 mW/g; SAR(10 g) = 0.804 mW/g

Maximum value of SAR (measured) = 1.17 mW/g

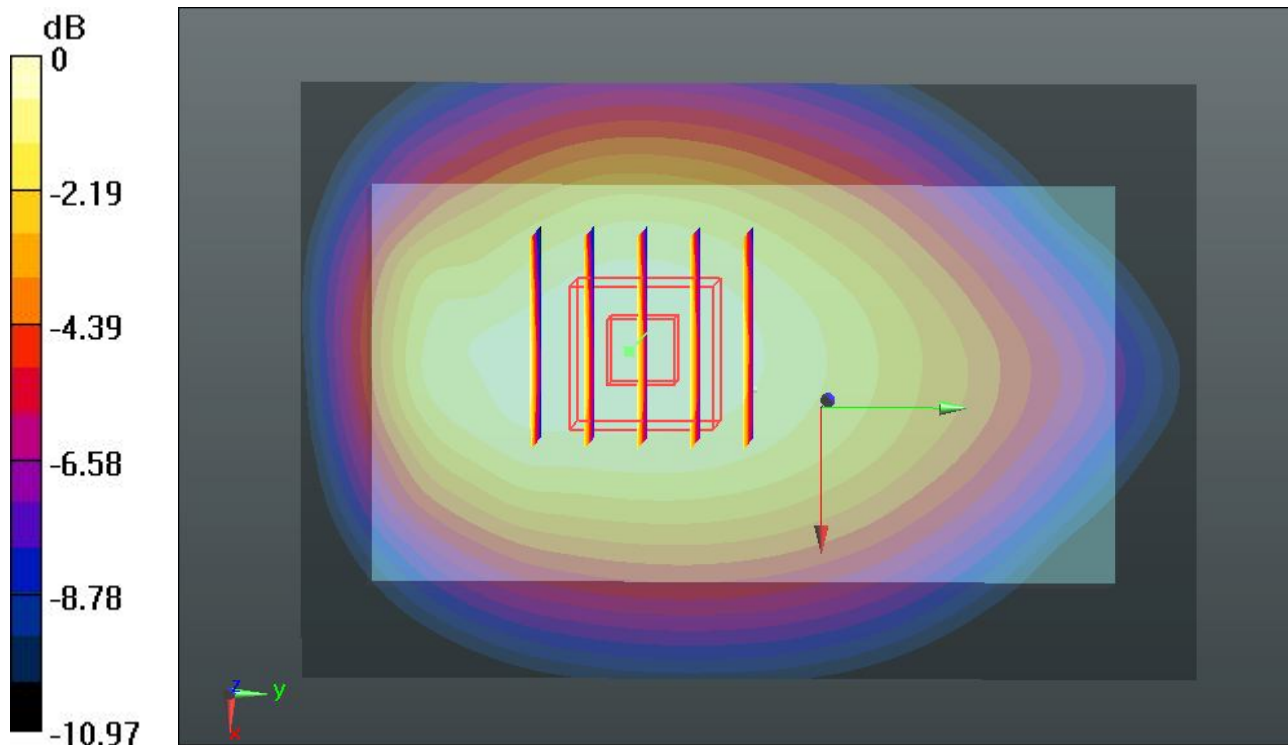

0 dB = 1.17 mW/g = 1.36 dB mW/g

51 GSM850_GPRS12_Back_1cm_Ch128_Headset

DUT: 251703

Communication System: GPRS/EDGE12; Frequency: 824.2 MHz; Duty Cycle: 1:2
Medium: MSL_835_120806 Medium parameters used: $f = 824.2 \text{ MHz}$; $\sigma = 0.966 \text{ mho/m}$; $\epsilon_r = 54.465$; $\rho = 1000 \text{ kg/m}^3$
Ambient Temperature : $23.7 \text{ }^\circ\text{C}$; Liquid Temperature : $21.4 \text{ }^\circ\text{C}$

DASY5 Configuration:

- Probe: ES3DV3 - SN3270; ConvF(6.16, 6.16, 6.16); Calibrated: 12.09.2011;
- Sensor-Surface: 4mm (Mechanical Surface Detection)
- Electronics: DAE4 Sn1303; Calibrated: 10.11.2011
- Phantom: SAM1; Type: QD000P40CD; Serial: TP:1670
- Measurement SW: DASY52, Version 52.8 (1); SEMCAD X Version 14.6.5 (6469)

Ch128/Area Scan (61x91x1): Measurement grid: $dx=15\text{mm}$, $dy=15\text{mm}$
Maximum value of SAR (interpolated) = 1.09 mW/g

Ch128/Zoom Scan (5x5x7)/Cube 0: Measurement grid: $dx=8\text{mm}$, $dy=8\text{mm}$, $dz=5\text{mm}$
Reference Value = 31.709 V/m ; Power Drift = 0.01 dB
Peak SAR (extrapolated) = 1.390 mW/g
SAR(1 g) = 1.050 mW/g ; SAR(10 g) = 0.766 mW/g
Maximum value of SAR (measured) = 1.11 mW/g

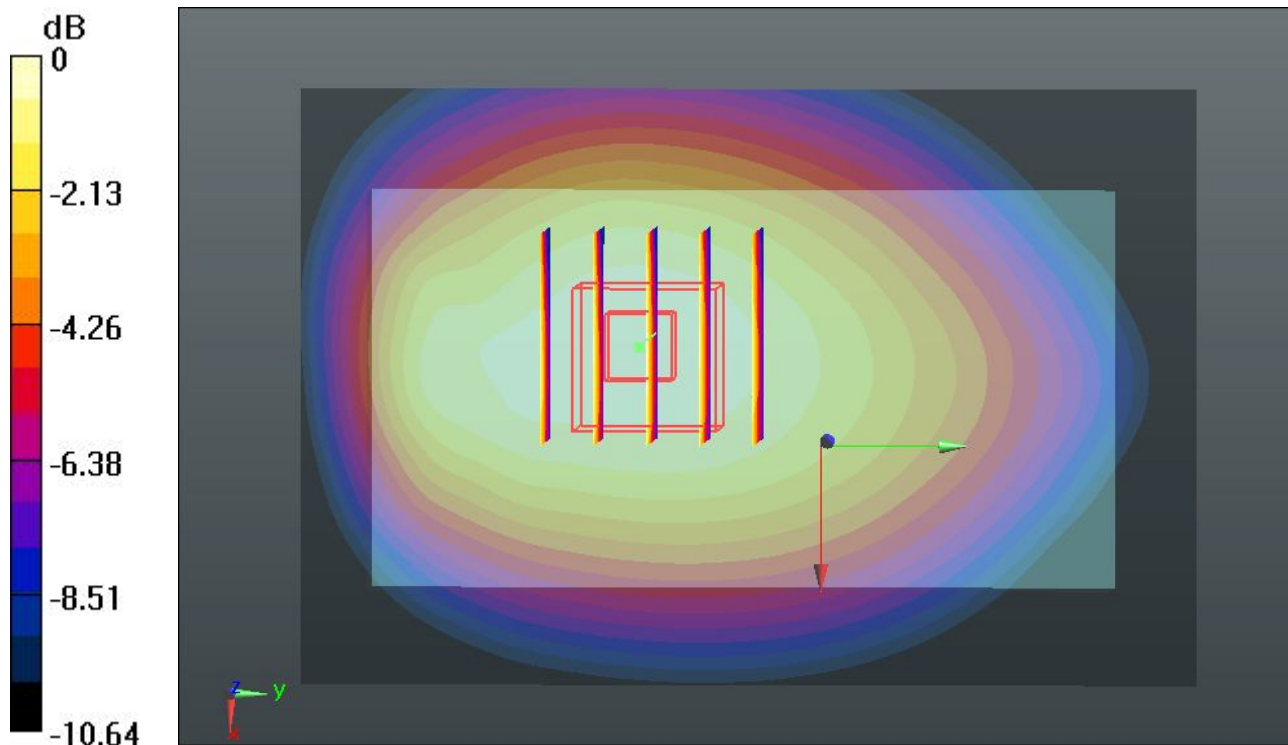

0 dB = 1.11 mW/g = 0.91 dB mW/g

52 GSM850_GPRS12_Back_1cm_Ch189_Headset

DUT: 251703

Communication System: GPRS/EDGE12; Frequency: 836.4 MHz; Duty Cycle: 1:2
Medium: MSL_835_120806 Medium parameters used: $f = 836.4 \text{ MHz}$; $\sigma = 0.978 \text{ mho/m}$; $\epsilon_r = 54.378$; $\rho = 1000 \text{ kg/m}^3$
Ambient Temperature : $23.7 \text{ }^\circ\text{C}$; Liquid Temperature : $21.4 \text{ }^\circ\text{C}$

DASY5 Configuration:

- Probe: ES3DV3 - SN3270; ConvF(6.16, 6.16, 6.16); Calibrated: 12.09.2011;
- Sensor-Surface: 4mm (Mechanical Surface Detection)
- Electronics: DAE4 Sn1303; Calibrated: 10.11.2011
- Phantom: SAM1; Type: QD000P40CD; Serial: TP:1670
- Measurement SW: DASY52, Version 52.8 (1); SEMCAD X Version 14.6.5 (6469)

Ch189/Area Scan (61x91x1): Measurement grid: $dx=15\text{mm}$, $dy=15\text{mm}$
Maximum value of SAR (interpolated) = 1.13 mW/g

Ch189/Zoom Scan (5x5x7)/Cube 0: Measurement grid: $dx=8\text{mm}$, $dy=8\text{mm}$, $dz=5\text{mm}$
Reference Value = 29.508 V/m ; Power Drift = -0.10 dB
Peak SAR (extrapolated) = 1.424 mW/g
SAR(1 g) = 1.060 mW/g ; SAR(10 g) = 0.766 mW/g
Maximum value of SAR (measured) = 1.12 mW/g

Ch189/Zoom Scan (5x5x7)/Cube 1: Measurement grid: $dx=8\text{mm}$, $dy=8\text{mm}$, $dz=5\text{mm}$
Reference Value = 29.508 V/m ; Power Drift = -0.10 dB
Peak SAR (extrapolated) = 1.496 mW/g
SAR(1 g) = 1.010 mW/g ; SAR(10 g) = 0.705 mW/g
Maximum value of SAR (measured) = 1.10 mW/g

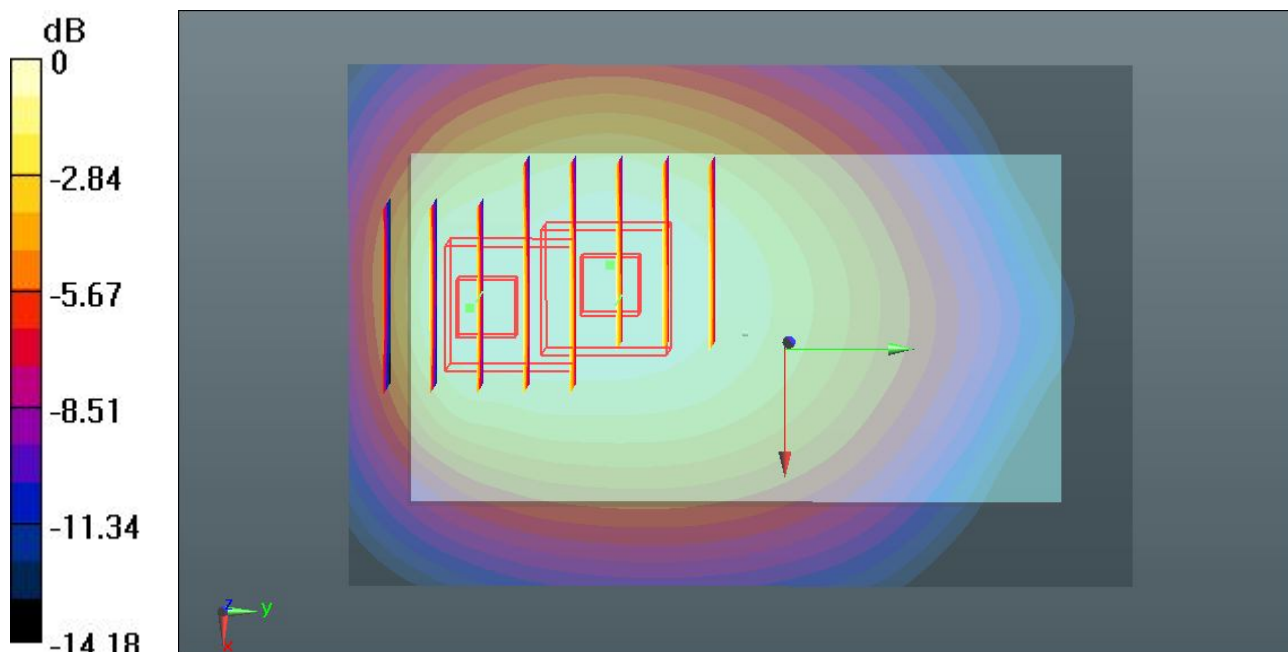

0 dB = 1.10 mW/g = 0.83 dB mW/g

21 GSM1900_GPRS12_Front_1cm_Ch810

DUT: 251703

Communication System: GPRS/EDGE12; Frequency: 1909.8 MHz; Duty Cycle: 1:2

Medium: MSL_1900_120806 Medium parameters used: $f = 1910$ MHz; $\sigma = 1.529$ mho/m; $\epsilon_r =$

53.552 ; $\rho = 1000$ kg/m³

Ambient Temperature : 23.5 °C ; Liquid Temperature : 21.5 °C

DASY5 Configuration:

- Probe: ES3DV3 - SN3270; ConvF(4.64, 4.64, 4.64); Calibrated: 12.09.2011;
- Sensor-Surface: 4mm (Mechanical Surface Detection)
- Electronics: DAE4 Sn1303; Calibrated: 10.11.2011
- Phantom: SAM2; Type: QD000P40CD; Serial: TP:1671
- Measurement SW: DASY52, Version 52.8 (1); SEMCAD X Version 14.6.5 (6469)

Ch810/Area Scan (61x91x1): Measurement grid: dx=15mm, dy=15mm

Maximum value of SAR (interpolated) = 0.870 mW/g

Ch810/Zoom Scan (5x5x7)/Cube 0: Measurement grid: dx=8mm, dy=8mm, dz=5mm

Reference Value = 13.358 V/m; Power Drift = -0.10 dB

Peak SAR (extrapolated) = 1.242 mW/g

SAR(1 g) = 0.755 mW/g; SAR(10 g) = 0.461 mW/g

Maximum value of SAR (measured) = 0.816 mW/g

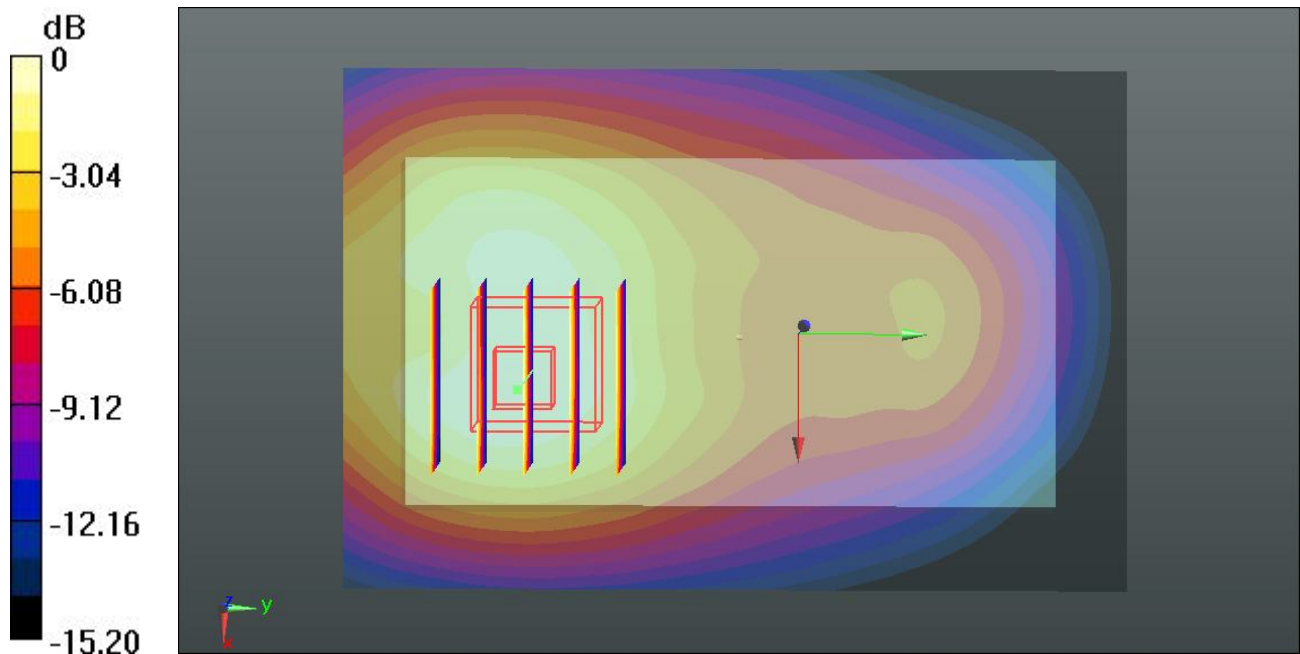

0 dB = 0.816 mW/g = -1.77 dB mW/g

22 GSM1900_GPRS12_Back_1cm_Ch810

DUT: 251703

Communication System: GPRS/EDGE12; Frequency: 1909.8 MHz; Duty Cycle: 1:2
 Medium: MSL_1900_120806 Medium parameters used: $f = 1910 \text{ MHz}$; $\sigma = 1.529 \text{ mho/m}$; $\epsilon_r = 53.552$; $\rho = 1000 \text{ kg/m}^3$
 Ambient Temperature : $23.5 \text{ }^\circ\text{C}$; Liquid Temperature : $21.5 \text{ }^\circ\text{C}$

DASY5 Configuration:

- Probe: ES3DV3 - SN3270; ConvF(4.64, 4.64, 4.64); Calibrated: 12.09.2011;
- Sensor-Surface: 4mm (Mechanical Surface Detection)
- Electronics: DAE4 Sn1303; Calibrated: 10.11.2011
- Phantom: SAM2; Type: QD000P40CD; Serial: TP:1671
- Measurement SW: DASY52, Version 52.8 (1); SEMCAD X Version 14.6.5 (6469)

Ch810/Area Scan (61x91x1): Measurement grid: $dx=15\text{mm}$, $dy=15\text{mm}$
 Maximum value of SAR (interpolated) = 0.961 mW/g

Ch810/Zoom Scan (5x5x7)/Cube 0: Measurement grid: $dx=8\text{mm}$, $dy=8\text{mm}$, $dz=5\text{mm}$
 Reference Value = 15.314 V/m ; Power Drift = -0.04 dB
 Peak SAR (extrapolated) = 1.554 mW/g
SAR(1 g) = 0.895 mW/g ; SAR(10 g) = 0.527 mW/g
 Maximum value of SAR (measured) = 0.960 mW/g

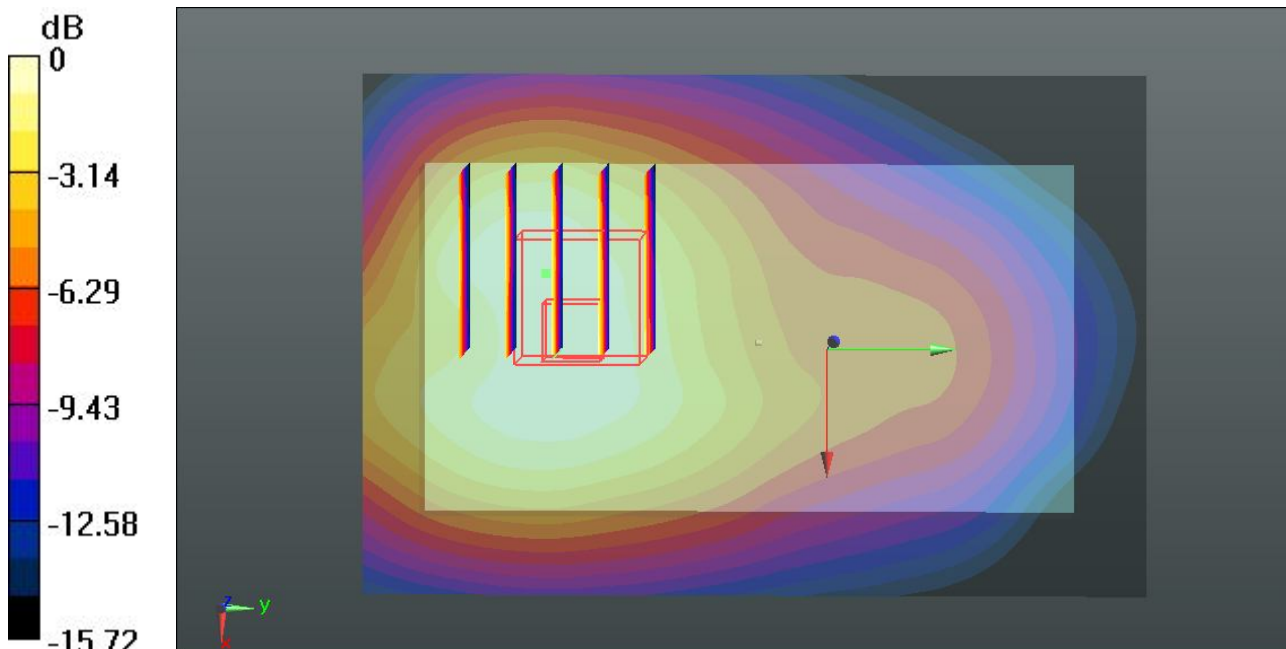

0 dB = 0.960 mW/g = -0.35 dB mW/g

23 GSM1900_GPRS12_Left Side_1cm_Ch810

DUT: 251703

Communication System: GPRS/EDGE12; Frequency: 1909.8 MHz; Duty Cycle: 1:2
 Medium: MSL_1900_120806 Medium parameters used: $f = 1910 \text{ MHz}$; $\sigma = 1.529 \text{ mho/m}$; $\epsilon_r = 53.552$; $\rho = 1000 \text{ kg/m}^3$
 Ambient Temperature : $23.5 \text{ }^\circ\text{C}$; Liquid Temperature : $21.5 \text{ }^\circ\text{C}$

DASY5 Configuration:

- Probe: ES3DV3 - SN3270; ConvF(4.64, 4.64, 4.64); Calibrated: 12.09.2011;
- Sensor-Surface: 4mm (Mechanical Surface Detection)
- Electronics: DAE4 Sn1303; Calibrated: 10.11.2011
- Phantom: SAM2; Type: QD000P40CD; Serial: TP:1671
- Measurement SW: DASY52, Version 52.8 (1); SEMCAD X Version 14.6.5 (6469)

Ch810/Area Scan (41x91x1): Measurement grid: $dx=15\text{mm}$, $dy=15\text{mm}$
 Maximum value of SAR (interpolated) = 0.223 mW/g

Ch810/Zoom Scan (5x5x7)/Cube 0: Measurement grid: $dx=8\text{mm}$, $dy=8\text{mm}$, $dz=5\text{mm}$
 Reference Value = 10.789 V/m ; Power Drift = 0.04 dB
 Peak SAR (extrapolated) = 0.332 mW/g
SAR(1 g) = 0.206 mW/g ; SAR(10 g) = 0.125 mW/g
 Maximum value of SAR (measured) = 0.223 mW/g

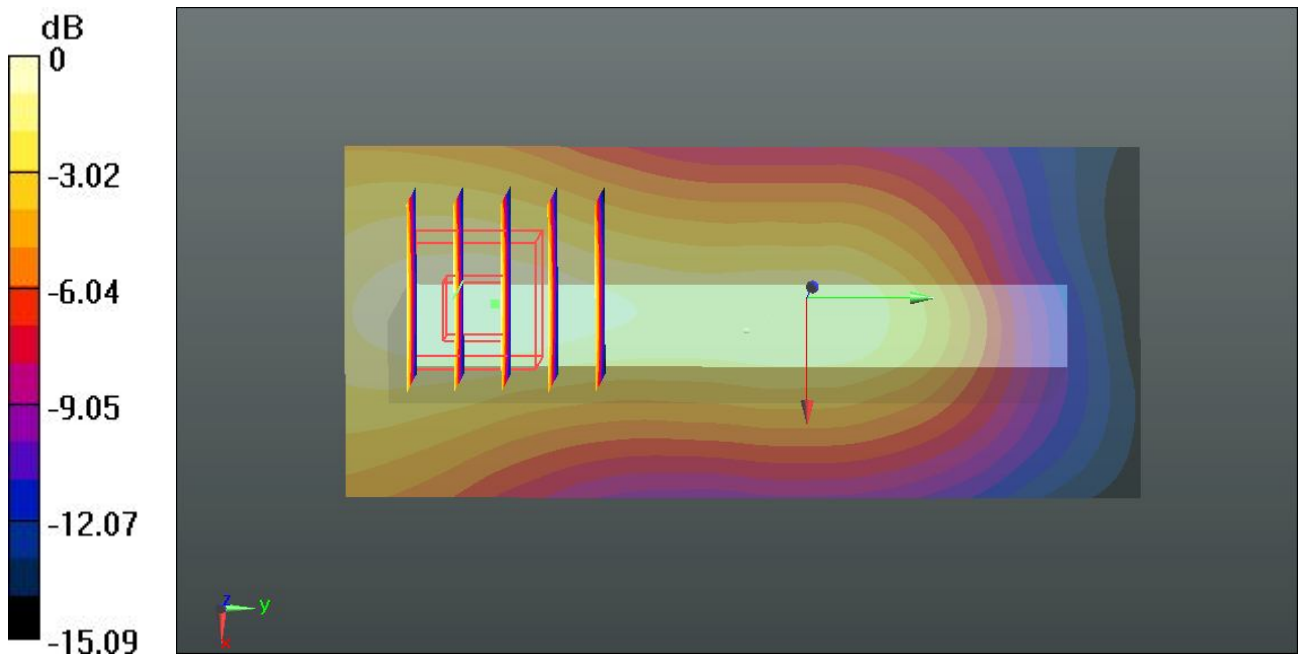

0 dB = 0.223 mW/g = -13.03 dB mW/g

24 GSM1900_GPRS12_Right Side_1cm_Ch810

DUT: 251703

Communication System: GPRS/EDGE12; Frequency: 1909.8 MHz; Duty Cycle: 1:2
 Medium: MSL_1900_120806 Medium parameters used: $f = 1910$ MHz; $\sigma = 1.529$ mho/m; $\epsilon_r = 53.552$; $\rho = 1000$ kg/m³
 Ambient Temperature : 23.5 °C ; Liquid Temperature : 21.5 °C

DASY5 Configuration:

- Probe: ES3DV3 - SN3270; ConvF(4.64, 4.64, 4.64); Calibrated: 12.09.2011;
- Sensor-Surface: 4mm (Mechanical Surface Detection)
- Electronics: DAE4 Sn1303; Calibrated: 10.11.2011
- Phantom: SAM2; Type: QD000P40CD; Serial: TP:1671
- Measurement SW: DASY52, Version 52.8 (1); SEMCAD X Version 14.6.5 (6469)

Ch810/Area Scan (41x91x1): Measurement grid: dx=15mm, dy=15mm

Maximum value of SAR (interpolated) = 0.197 mW/g

Ch810/Zoom Scan (5x5x7)/Cube 0: Measurement grid: dx=8mm, dy=8mm, dz=5mm

Reference Value = 11.388 V/m; Power Drift = -0.02 dB

Peak SAR (extrapolated) = 0.289 mW/g

SAR(1 g) = 0.179 mW/g; SAR(10 g) = 0.108 mW/g

Maximum value of SAR (measured) = 0.195 mW/g

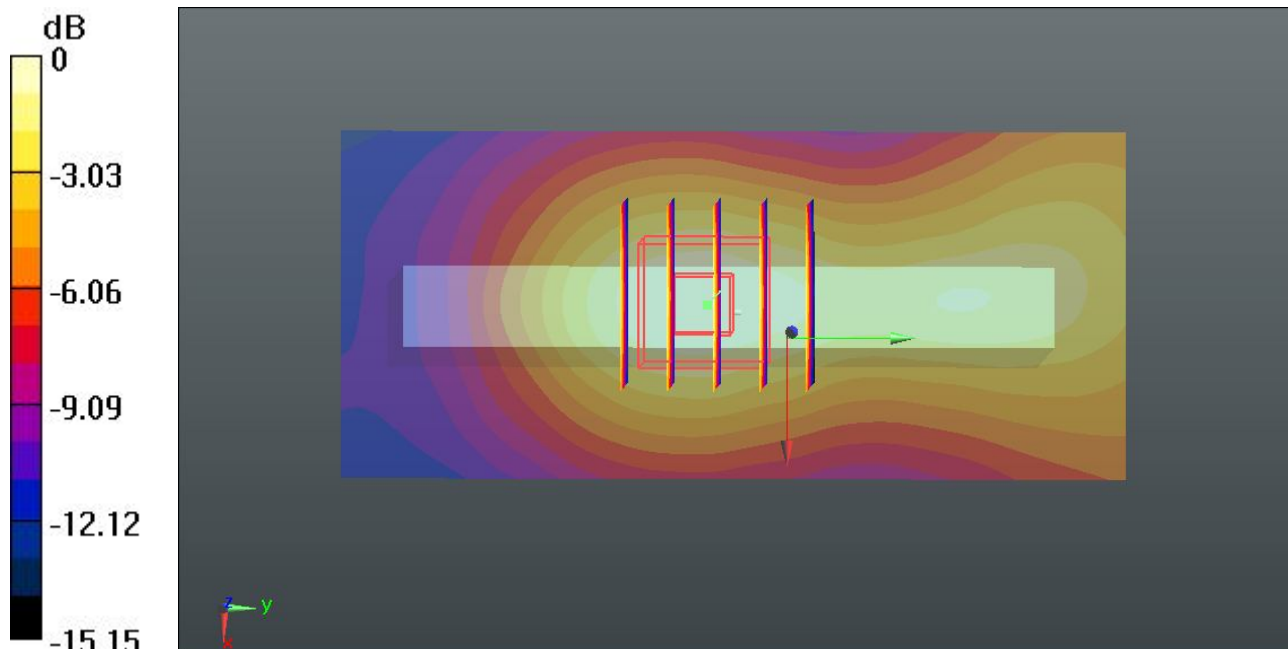

0 dB = 0.195 mW/g = -14.20 dB mW/g

25 GSM1900_GPRS12_Bottom Side_1cm_Ch810

DUT: 251703

Communication System: GPRS/EDGE12; Frequency: 1909.8 MHz; Duty Cycle: 1:2

Medium: MSL_1900_120806 Medium parameters used: $f = 1910$ MHz; $\sigma = 1.529$ mho/m; $\epsilon_r =$

53.552 ; $\rho = 1000$ kg/m³

Ambient Temperature : 23.5 °C ; Liquid Temperature : 21.5 °C

DASY5 Configuration:

- Probe: ES3DV3 - SN3270; ConvF(4.64, 4.64, 4.64); Calibrated: 12.09.2011;
- Sensor-Surface: 4mm (Mechanical Surface Detection)
- Electronics: DAE4 Sn1303; Calibrated: 10.11.2011
- Phantom: SAM2; Type: QD000P40CD; Serial: TP:1671
- Measurement SW: DASY52, Version 52.8 (1); SEMCAD X Version 14.6.5 (6469)

Ch810/Area Scan (41x61x1): Measurement grid: dx=15mm, dy=15mm

Maximum value of SAR (interpolated) = 0.660 mW/g

Ch810/Zoom Scan (5x5x7)/Cube 0: Measurement grid: dx=8mm, dy=8mm, dz=5mm

Reference Value = 13.074 V/m; Power Drift = -0.13 dB

Peak SAR (extrapolated) = 0.995 mW/g

SAR(1 g) = 0.599 mW/g; SAR(10 g) = 0.329 mW/g

Maximum value of SAR (measured) = 0.680 mW/g

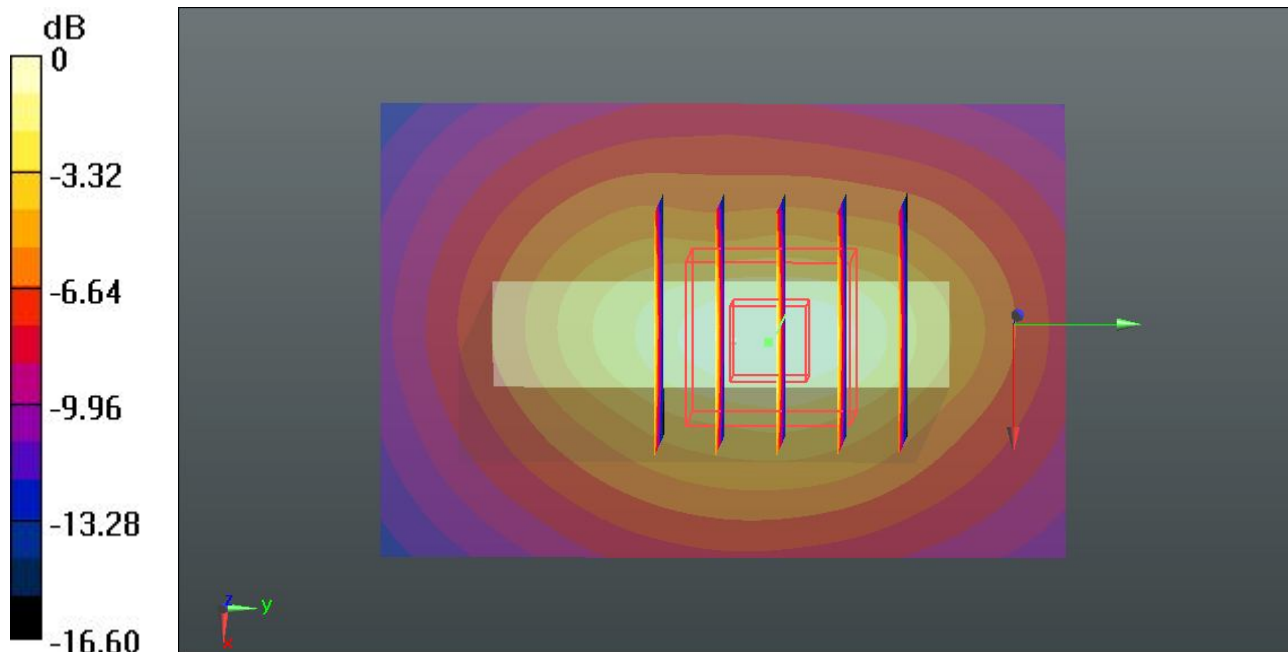

0 dB = 0.680 mW/g = -3.35 dB mW/g

26 GSM1900_GPRS12_Back_1cm_Ch512

DUT: 251703

Communication System: GPRS/EDGE12; Frequency: 1850.2 MHz; Duty Cycle: 1:2
Medium: MSL_1900_120806 Medium parameters used: $f = 1850.2$ MHz; $\sigma = 1.459$ mho/m; $\epsilon_r = 53.59$; $\rho = 1000$ kg/m³
Ambient Temperature : 23.5 °C ; Liquid Temperature : 21.5 °C

DASY5 Configuration:

- Probe: ES3DV3 - SN3270; ConvF(4.64, 4.64, 4.64); Calibrated: 12.09.2011;
- Sensor-Surface: 4mm (Mechanical Surface Detection)
- Electronics: DAE4 Sn1303; Calibrated: 10.11.2011
- Phantom: SAM2; Type: QD000P40CD; Serial: TP:1671
- Measurement SW: DASY52, Version 52.8 (1); SEMCAD X Version 14.6.5 (6469)

Ch512/Area Scan (61x91x1): Measurement grid: dx=15mm, dy=15mm
Maximum value of SAR (interpolated) = 1.07 mW/g

Ch512/Zoom Scan (5x5x7)/Cube 0: Measurement grid: dx=8mm, dy=8mm, dz=5mm
Reference Value = 15.270 V/m; Power Drift = -0.02 dB
Peak SAR (extrapolated) = 1.637 mW/g
SAR(1 g) = 0.998 mW/g; SAR(10 g) = 0.602 mW/g
Maximum value of SAR (measured) = 1.08 mW/g

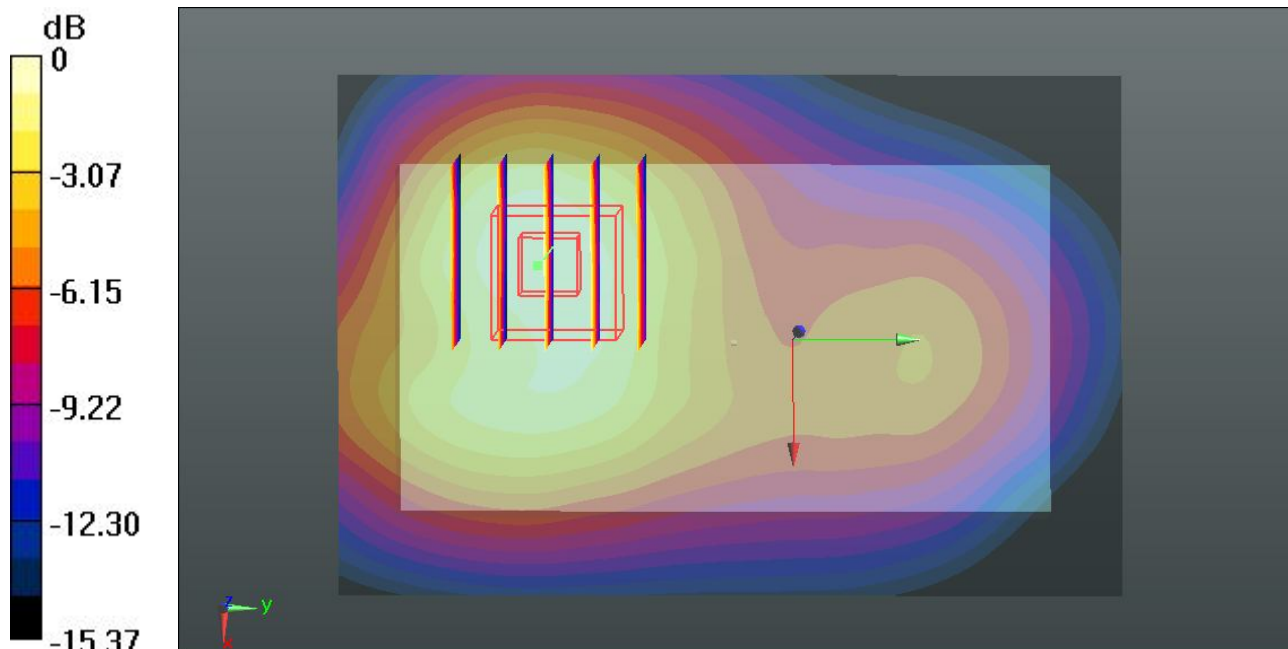

0 dB = 1.08 mW/g = 0.67 dB mW/g

26 GSM1900_GPRS12_Back_1cm_Ch512_2D

DUT: 251703

Communication System: GPRS/EDGE12; Frequency: 1850.2 MHz; Duty Cycle: 1:2
Medium: MSL_1900_120806 Medium parameters used: $f = 1850.2$ MHz; $\sigma = 1.459$ mho/m; $\epsilon_r = 53.59$; $\rho = 1000$ kg/m³
Ambient Temperature : 23.5 °C ; Liquid Temperature : 21.5 °C

DASY5 Configuration:

- Probe: ES3DV3 - SN3270; ConvF(4.64, 4.64, 4.64); Calibrated: 12.09.2011;
- Sensor-Surface: 4mm (Mechanical Surface Detection)
- Electronics: DAE4 Sn1303; Calibrated: 10.11.2011
- Phantom: SAM2; Type: QD000P40CD; Serial: TP:1671
- Measurement SW: DASY52, Version 52.8 (1); SEMCAD X Version 14.6.5 (6469)

Ch512/Area Scan (61x91x1): Measurement grid: dx=15mm, dy=15mm
Maximum value of SAR (interpolated) = 1.07 mW/g

Ch512/Zoom Scan (5x5x7)/Cube 0: Measurement grid: dx=8mm, dy=8mm, dz=5mm
Reference Value = 15.270 V/m; Power Drift = -0.02 dB
Peak SAR (extrapolated) = 1.637 mW/g
SAR(1 g) = 0.998 mW/g; SAR(10 g) = 0.602 mW/g
Maximum value of SAR (measured) = 1.08 mW/g

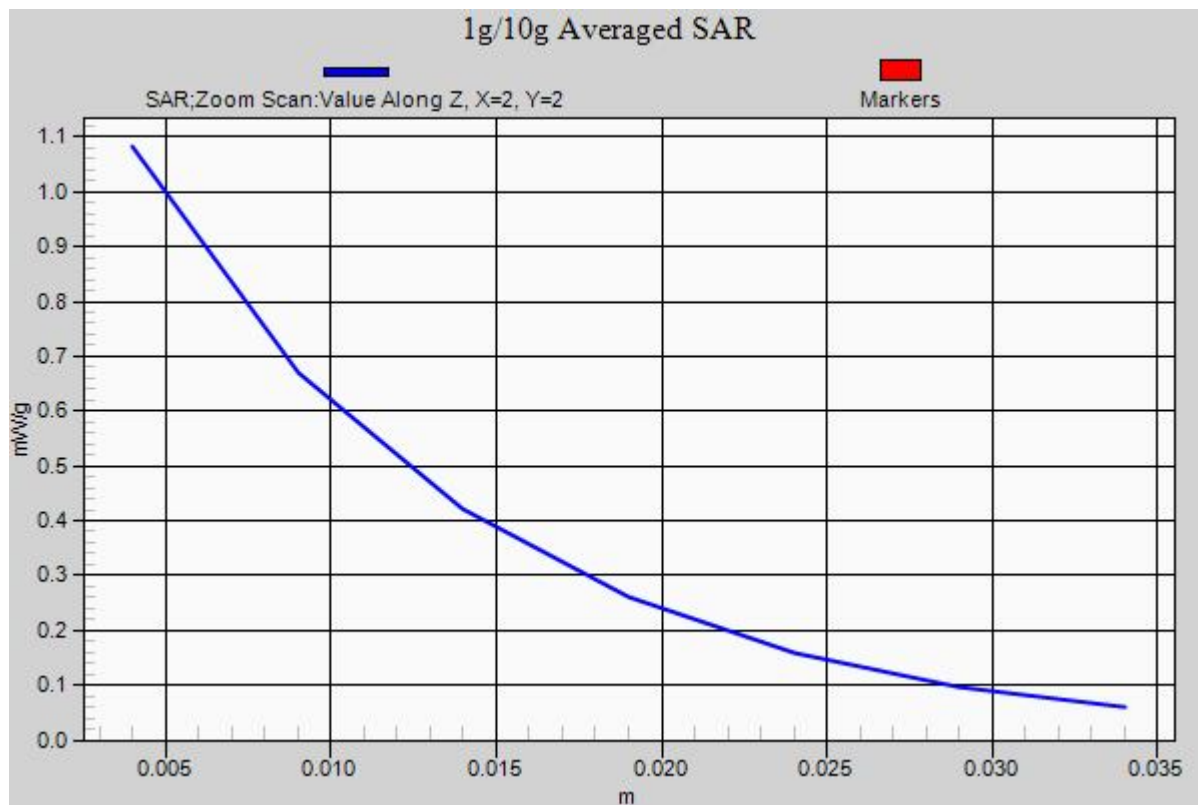

27 GSM1900_GPRS12_Back_1cm_Ch661

DUT: 251703

Communication System: GPRS/EDGE12; Frequency: 1880 MHz; Duty Cycle: 1:2
 Medium: MSL_1900_120806 Medium parameters used: $f = 1880$ MHz; $\sigma = 1.498$ mho/m; $\epsilon_r = 53.575$; $\rho = 1000$ kg/m³
 Ambient Temperature : 23.5 °C ; Liquid Temperature : 21.5 °C

DASY5 Configuration:

- Probe: ES3DV3 - SN3270; ConvF(4.64, 4.64, 4.64); Calibrated: 12.09.2011;
- Sensor-Surface: 4mm (Mechanical Surface Detection)
- Electronics: DAE4 Sn1303; Calibrated: 10.11.2011
- Phantom: SAM2; Type: QD000P40CD; Serial: TP:1671
- Measurement SW: DASY52, Version 52.8 (1); SEMCAD X Version 14.6.5 (6469)

Ch661/Area Scan (61x91x1): Measurement grid: dx=15mm, dy=15mm
 Maximum value of SAR (interpolated) = 0.951 mW/g

Ch661/Zoom Scan (5x5x7)/Cube 0: Measurement grid: dx=8mm, dy=8mm, dz=5mm
 Reference Value = 14.976 V/m; Power Drift = 0.01 dB
 Peak SAR (extrapolated) = 1.480 mW/g
SAR(1 g) = 0.894 mW/g; SAR(10 g) = 0.541 mW/g
 Maximum value of SAR (measured) = 0.957 mW/g

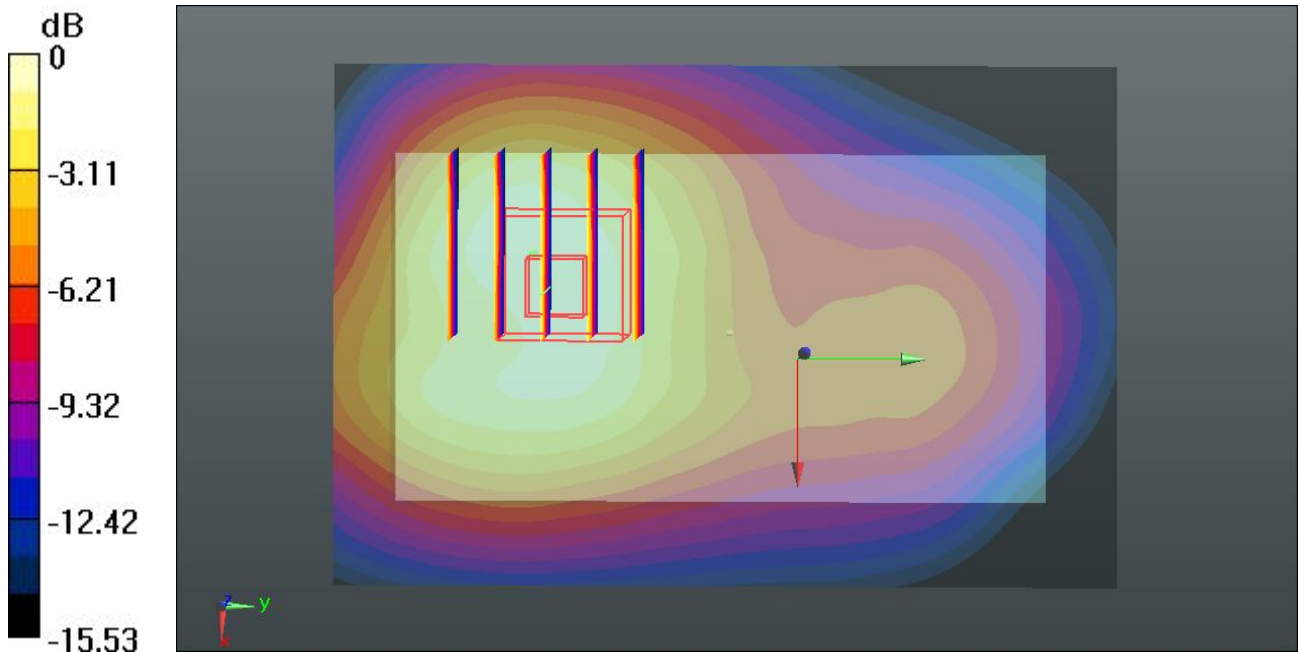

0 dB = 0.957 mW/g = -0.38 dB mW/g

28 GSM1900_GPRS12_Back_1cm_Ch512_Headset

DUT: 251703

Communication System: GPRS/EDGE12; Frequency: 1850.2 MHz; Duty Cycle: 1:2

Medium: MSL_1900_120806 Medium parameters used: $f = 1850.2$ MHz; $\sigma = 1.459$ mho/m; $\epsilon_r =$

53.59 ; $\rho = 1000$ kg/m³

Ambient Temperature : 23.5 °C ; Liquid Temperature : 21.5 °C

DASY5 Configuration:

- Probe: ES3DV3 - SN3270; ConvF(4.64, 4.64, 4.64); Calibrated: 12.09.2011;
- Sensor-Surface: 4mm (Mechanical Surface Detection)
- Electronics: DAE4 Sn1303; Calibrated: 10.11.2011
- Phantom: SAM2; Type: QD000P40CD; Serial: TP:1671
- Measurement SW: DASY52, Version 52.8 (1); SEMCAD X Version 14.6.5 (6469)

Ch512/Area Scan (61x91x1): Measurement grid: dx=15mm, dy=15mm

Maximum value of SAR (interpolated) = 1.08 mW/g

Ch512/Zoom Scan (5x5x7)/Cube 0: Measurement grid: dx=8mm, dy=8mm, dz=5mm

Reference Value = 15.731 V/m; Power Drift = -0.03 dB

Peak SAR (extrapolated) = 1.588 mW/g

SAR(1 g) = 0.972 mW/g; SAR(10 g) = 0.589 mW/g

Maximum value of SAR (measured) = 1.05 mW/g

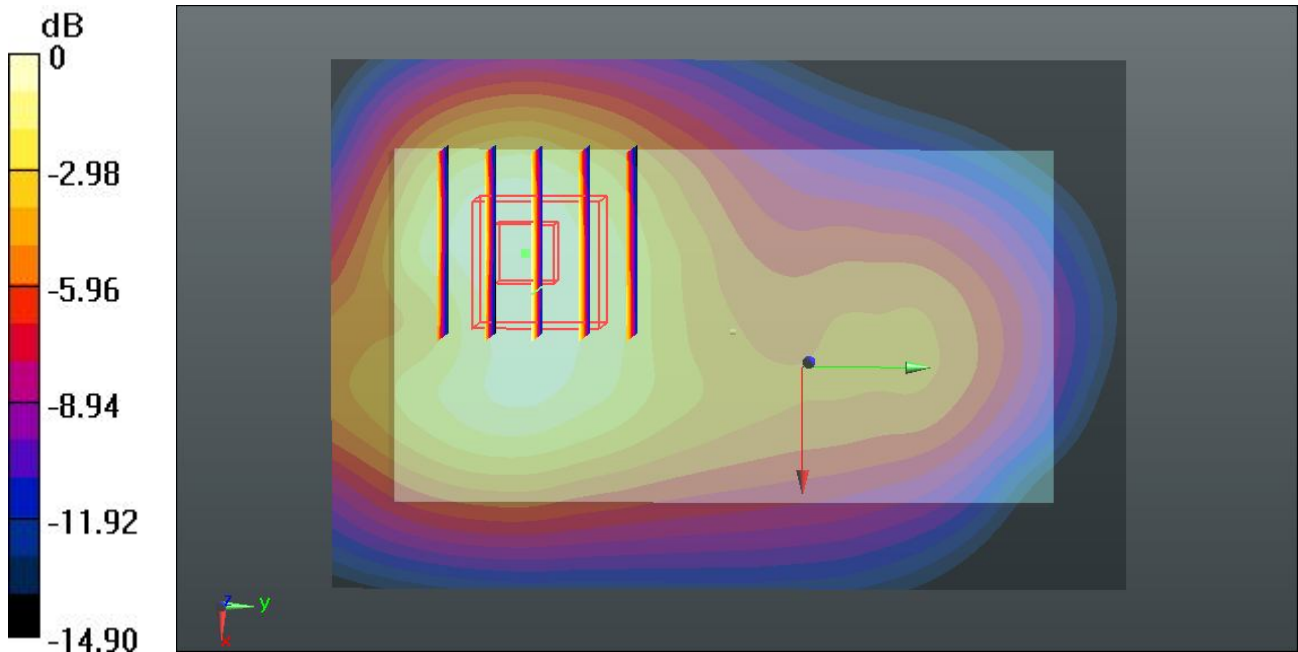

0 dB = 1.05 mW/g = 0.42 dB mW/g

29 GSM1900_GPRS12_Back_1cm_Ch661_Headset

DUT: 251703

Communication System: GPRS/EDGE12; Frequency: 1880 MHz; Duty Cycle: 1:2
 Medium: MSL_1900_120806 Medium parameters used: $f = 1880$ MHz; $\sigma = 1.498$ mho/m; $\epsilon_r = 53.575$; $\rho = 1000$ kg/m³
 Ambient Temperature : 23.5 °C ; Liquid Temperature : 21.5 °C

DASY5 Configuration:

- Probe: ES3DV3 - SN3270; ConvF(4.64, 4.64, 4.64); Calibrated: 12.09.2011;
- Sensor-Surface: 4mm (Mechanical Surface Detection)
- Electronics: DAE4 Sn1303; Calibrated: 10.11.2011
- Phantom: SAM2; Type: QD000P40CD; Serial: TP:1671
- Measurement SW: DASY52, Version 52.8 (1); SEMCAD X Version 14.6.5 (6469)

Ch661/Area Scan (61x91x1): Measurement grid: dx=15mm, dy=15mm
 Maximum value of SAR (interpolated) = 0.983 mW/g

Ch661/Zoom Scan (5x5x7)/Cube 0: Measurement grid: dx=8mm, dy=8mm, dz=5mm
 Reference Value = 15.629 V/m; Power Drift = -0.07 dB
 Peak SAR (extrapolated) = 1.529 mW/g
SAR(1 g) = 0.911 mW/g; SAR(10 g) = 0.551 mW/g
 Maximum value of SAR (measured) = 0.976 mW/g

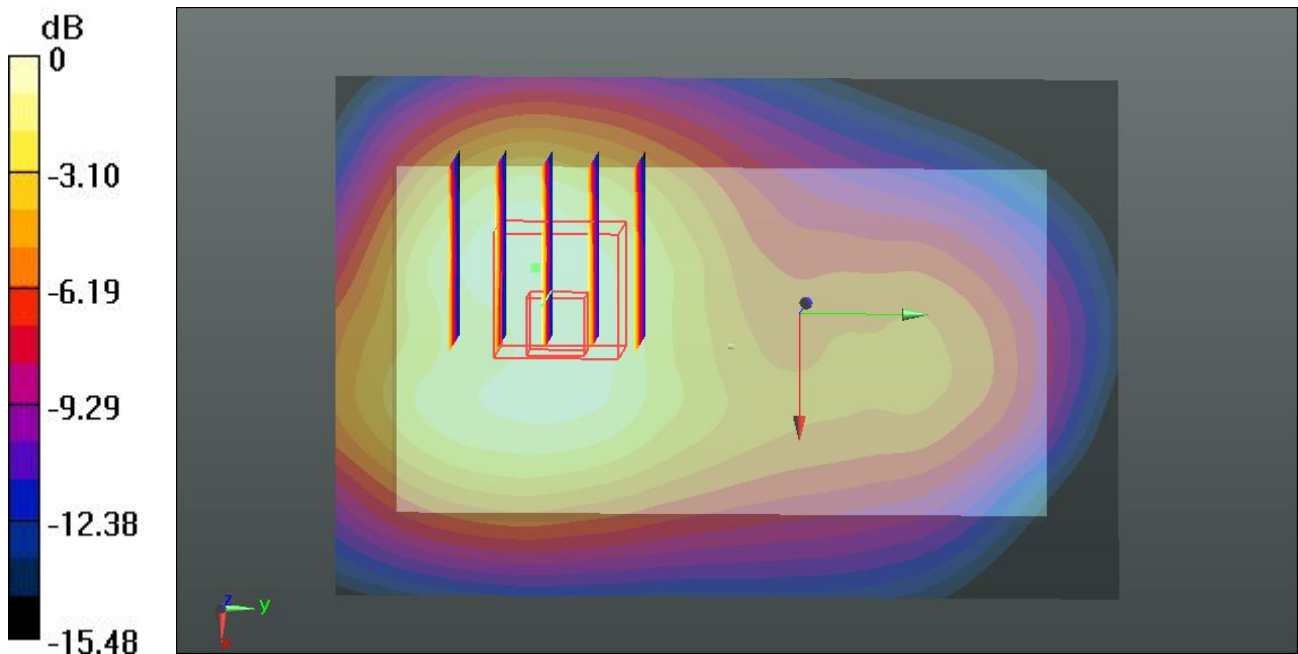

0 dB = 0.976 mW/g = -0.21 dB mW/g

30 GSM1900_GPRS12_Back_1cm_Ch810_Headset

DUT: 251703

Communication System: GPRS/EDGE12; Frequency: 1909.8 MHz; Duty Cycle: 1:2
Medium: MSL_1900_120806 Medium parameters used: $f = 1910$ MHz; $\sigma = 1.529$ mho/m; $\epsilon_r = 53.552$; $\rho = 1000$ kg/m³
Ambient Temperature : 23.5 °C ; Liquid Temperature : 21.5 °C

DASY5 Configuration:

- Probe: ES3DV3 - SN3270; ConvF(4.64, 4.64, 4.64); Calibrated: 12.09.2011;
- Sensor-Surface: 4mm (Mechanical Surface Detection)
- Electronics: DAE4 Sn1303; Calibrated: 10.11.2011
- Phantom: SAM2; Type: QD000P40CD; Serial: TP:1671
- Measurement SW: DASY52, Version 52.8 (1); SEMCAD X Version 14.6.5 (6469)

Ch810/Area Scan (61x91x1): Measurement grid: dx=15mm, dy=15mm
Maximum value of SAR (interpolated) = 0.821 mW/g

Ch810/Zoom Scan (5x5x7)/Cube 1: Measurement grid: dx=8mm, dy=8mm, dz=5mm
Reference Value = 15.203 V/m; Power Drift = -0.06 dB
Peak SAR (extrapolated) = 1.327 mW/g
SAR(1 g) = 0.793 mW/g; SAR(10 g) = 0.474 mW/g
Maximum value of SAR (measured) = 0.839 mW/g

Ch810/Zoom Scan (5x5x7)/Cube 0: Measurement grid: dx=8mm, dy=8mm, dz=5mm
Reference Value = 15.203 V/m; Power Drift = -0.06 dB
Peak SAR (extrapolated) = 1.348 mW/g
SAR(1 g) = 0.780 mW/g; SAR(10 g) = 0.465 mW/g
Maximum value of SAR (measured) = 0.834 mW/g

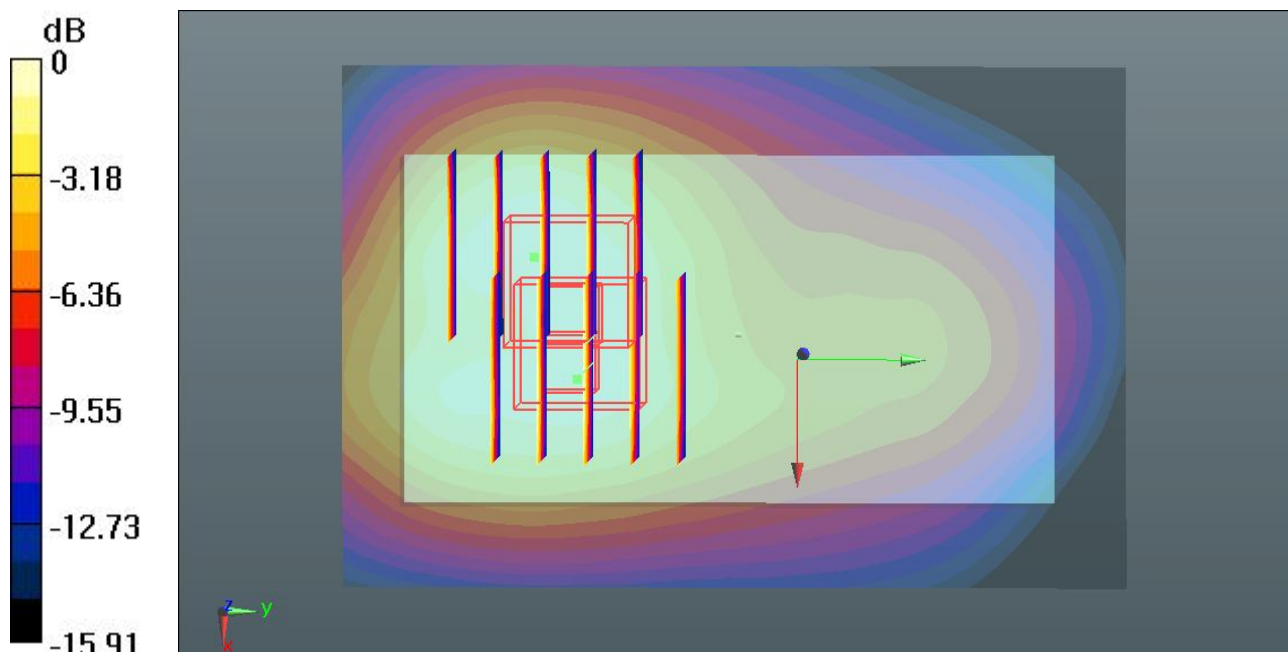

0 dB = 0.834 mW/g = -1.58 dB mW/g

53 WCDMA V_RMC 12.2K_Front_1cm_Ch4182

DUT: 251703

Communication System: UMTS; Frequency: 836.4 MHz; Duty Cycle: 1:1
Medium: MSL_835_120806 Medium parameters used: $f = 836.4 \text{ MHz}$; $\sigma = 0.978 \text{ mho/m}$; $\epsilon_r = 54.378$; $\rho = 1000 \text{ kg/m}^3$
Ambient Temperature : $23.7 \text{ }^\circ\text{C}$; Liquid Temperature : $21.4 \text{ }^\circ\text{C}$

DASY5 Configuration:

- Probe: ES3DV3 - SN3270; ConvF(6.16, 6.16, 6.16); Calibrated: 12.09.2011;
- Sensor-Surface: 4mm (Mechanical Surface Detection)
- Electronics: DAE4 Sn1303; Calibrated: 10.11.2011
- Phantom: SAM1; Type: QD000P40CD; Serial: TP:1670
- Measurement SW: DASY52, Version 52.8 (1); SEMCAD X Version 14.6.5 (6469)

Ch4182/Area Scan (61x91x1): Measurement grid: $dx=15\text{mm}$, $dy=15\text{mm}$
Maximum value of SAR (interpolated) = 0.604 mW/g

Ch4182/Zoom Scan (5x5x7)/Cube 0: Measurement grid: $dx=8\text{mm}$, $dy=8\text{mm}$, $dz=5\text{mm}$
Reference Value = 23.224 V/m ; Power Drift = 0.14 dB
Peak SAR (extrapolated) = 0.751 mW/g
SAR(1 g) = 0.575 mW/g ; SAR(10 g) = 0.426 mW/g
Maximum value of SAR (measured) = 0.604 mW/g

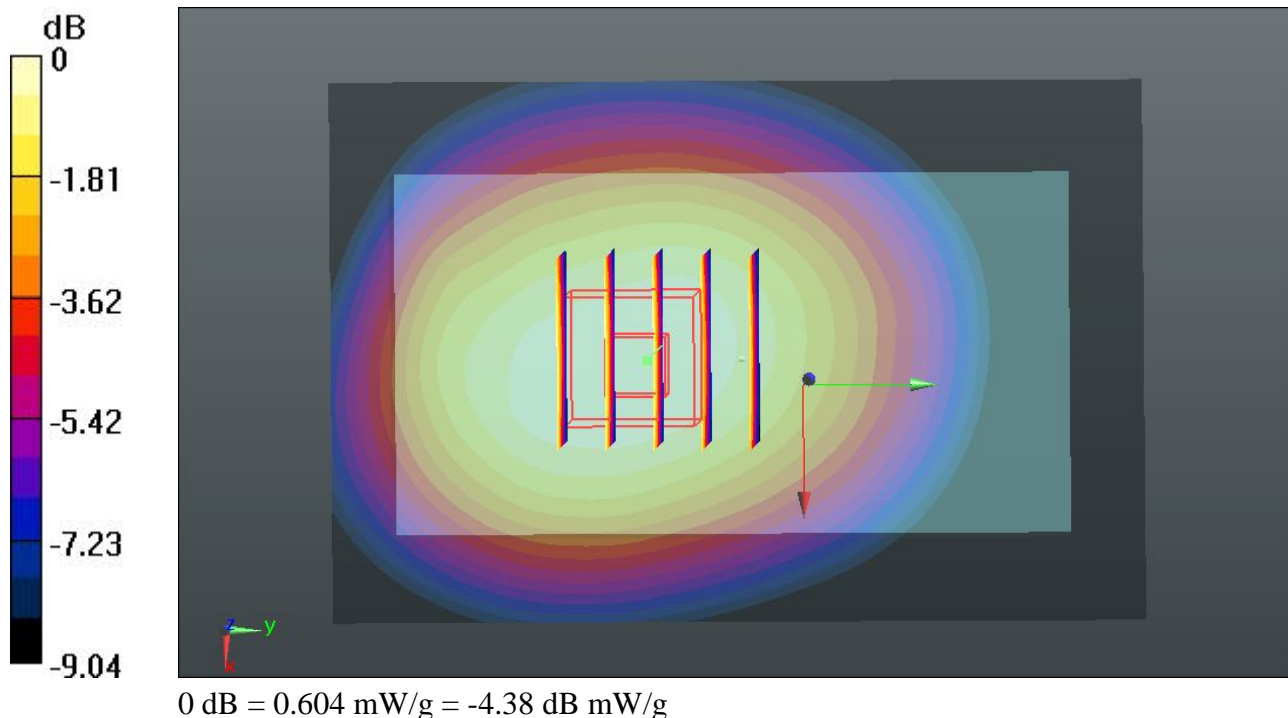

54 WCDMA V_RMC 12.2K_Back_1cm_Ch4182

DUT: 251703

Communication System: UMTS; Frequency: 836.4 MHz; Duty Cycle: 1:1

Medium: MSL_835_120806 Medium parameters used: $f = 836.4$ MHz; $\sigma = 0.978$ mho/m; $\epsilon_r =$

54.378; $\rho = 1000$ kg/m³

Ambient Temperature : 23.7 °C ; Liquid Temperature : 21.4 °C

DASY5 Configuration:

- Probe: ES3DV3 - SN3270; ConvF(6.16, 6.16, 6.16); Calibrated: 12.09.2011;
- Sensor-Surface: 4mm (Mechanical Surface Detection)
- Electronics: DAE4 Sn1303; Calibrated: 10.11.2011
- Phantom: SAM1; Type: QD000P40CD; Serial: TP:1670
- Measurement SW: DASY52, Version 52.8 (1); SEMCAD X Version 14.6.5 (6469)

Ch4182/Area Scan (61x91x1): Measurement grid: dx=15mm, dy=15mm

Maximum value of SAR (interpolated) = 0.719 mW/g

Ch4182/Zoom Scan (5x5x7)/Cube 0: Measurement grid: dx=8mm, dy=8mm, dz=5mm

Reference Value = 24.182 V/m; Power Drift = 0.08 dB

Peak SAR (extrapolated) = 0.922 mW/g

SAR(1 g) = 0.689 mW/g; SAR(10 g) = 0.499 mW/g

Maximum value of SAR (measured) = 0.720 mW/g

Ch4182/Zoom Scan (5x5x7)/Cube 1: Measurement grid: dx=8mm, dy=8mm, dz=5mm

Reference Value = 24.182 V/m; Power Drift = 0.08 dB

Peak SAR (extrapolated) = 0.876 mW/g

SAR(1 g) = 0.617 mW/g; SAR(10 g) = 0.430 mW/g

Maximum value of SAR (measured) = 0.686 mW/g

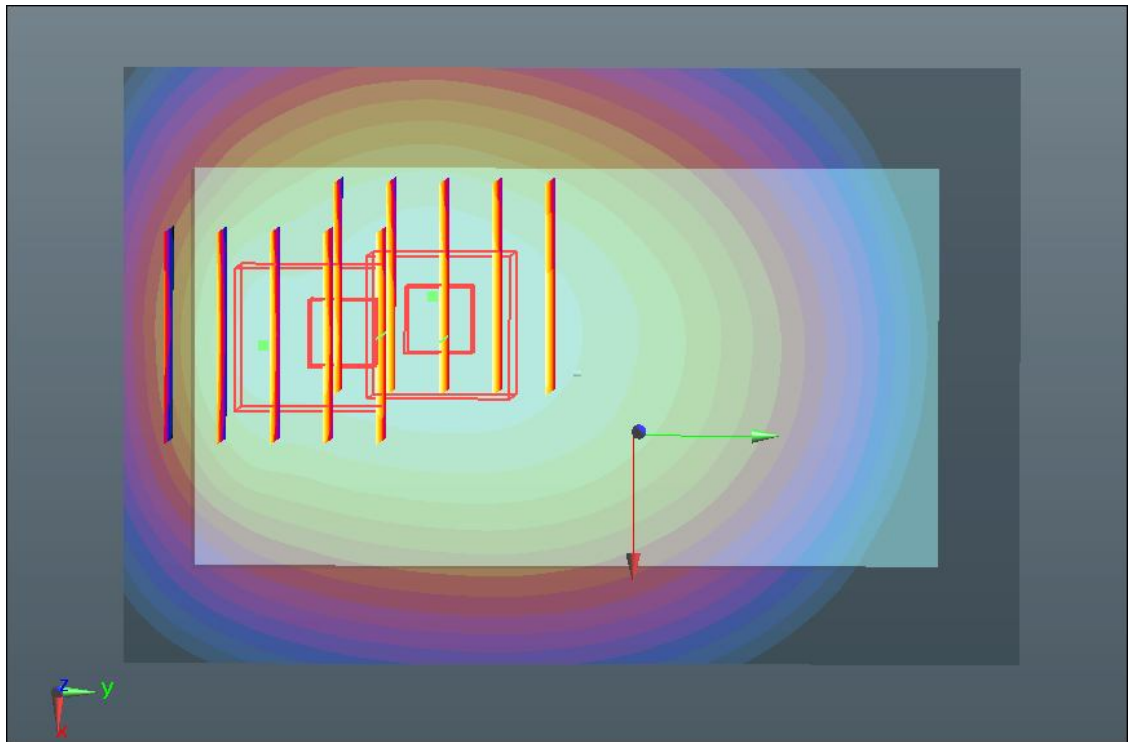
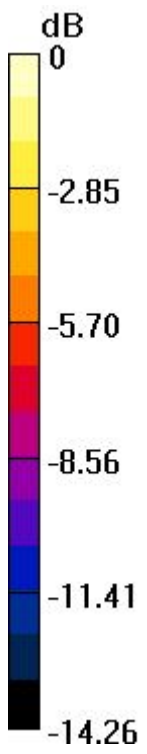

0 dB = 0.686 mW/g = -3.27 dB mW/g

54 WCDMA V_RMC 12.2K_Back_1cm_Ch4182_2D

DUT: 251703

Communication System: UMTS; Frequency: 836.4 MHz; Duty Cycle: 1:1

Medium: MSL_835_120806 Medium parameters used: $f = 836.4$ MHz; $\sigma = 0.978$ mho/m; $\epsilon_r =$

54.378 ; $\rho = 1000$ kg/m³

Ambient Temperature : 23.7 °C ; Liquid Temperature : 21.4 °C

DASY5 Configuration:

- Probe: ES3DV3 - SN3270; ConvF(6.16, 6.16, 6.16); Calibrated: 12.09.2011;
- Sensor-Surface: 4mm (Mechanical Surface Detection)
- Electronics: DAE4 Sn1303; Calibrated: 10.11.2011
- Phantom: SAM1; Type: QD000P40CD; Serial: TP:1670
- Measurement SW: DASY52, Version 52.8 (1); SEMCAD X Version 14.6.5 (6469)

Ch4182/Area Scan (61x91x1): Measurement grid: dx=15mm, dy=15mm

Maximum value of SAR (interpolated) = 0.719 mW/g

Ch4182/Zoom Scan (5x5x7)/Cube 0: Measurement grid: dx=8mm, dy=8mm, dz=5mm

Reference Value = 24.182 V/m; Power Drift = 0.08 dB

Peak SAR (extrapolated) = 0.922 mW/g

SAR(1 g) = 0.689 mW/g; SAR(10 g) = 0.499 mW/g

Maximum value of SAR (measured) = 0.720 mW/g

Ch4182/Zoom Scan (5x5x7)/Cube 1: Measurement grid: dx=8mm, dy=8mm, dz=5mm

Reference Value = 24.182 V/m; Power Drift = 0.08 dB

Peak SAR (extrapolated) = 0.876 mW/g

SAR(1 g) = 0.617 mW/g; SAR(10 g) = 0.430 mW/g

Maximum value of SAR (measured) = 0.686 mW/g

1g/10g Averaged SAR

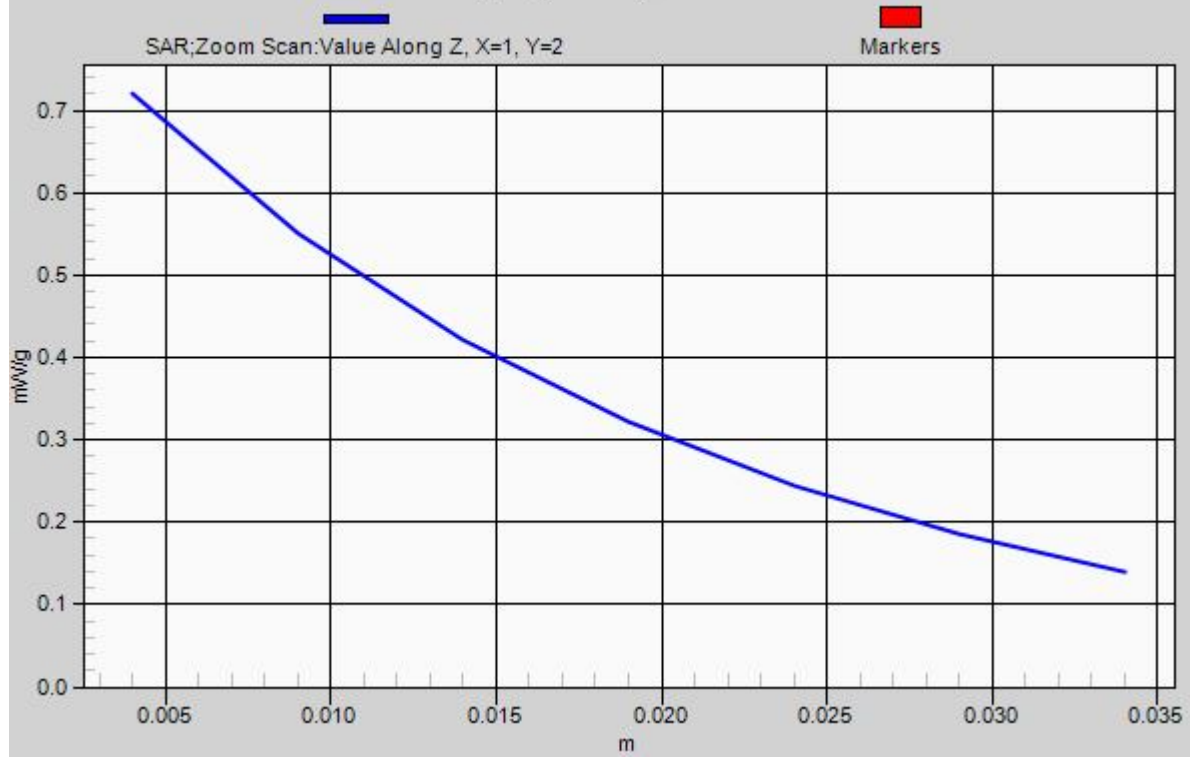

55 WCDMA V_RMC 12.2K_Left Side_1cm_Ch4182

DUT: 251703

Communication System: UMTS; Frequency: 836.4 MHz; Duty Cycle: 1:1

Medium: MSL_835_120806 Medium parameters used: $f = 836.4 \text{ MHz}$; $\sigma = 0.978 \text{ mho/m}$; $\epsilon_r =$

54.378 ; $\rho = 1000 \text{ kg/m}^3$

Ambient Temperature : $23.7 \text{ }^\circ\text{C}$; Liquid Temperature : $21.4 \text{ }^\circ\text{C}$

DASY5 Configuration:

- Probe: ES3DV3 - SN3270; ConvF(6.16, 6.16, 6.16); Calibrated: 12.09.2011;
- Sensor-Surface: 4mm (Mechanical Surface Detection)
- Electronics: DAE4 Sn1303; Calibrated: 10.11.2011
- Phantom: SAM1; Type: QD000P40CD; Serial: TP:1670
- Measurement SW: DASY52, Version 52.8 (1); SEMCAD X Version 14.6.5 (6469)

Ch4182/Area Scan (41x91x1): Measurement grid: $dx=15\text{mm}$, $dy=15\text{mm}$

Maximum value of SAR (interpolated) = 0.452 mW/g

Ch4182/Zoom Scan (5x5x7)/Cube 0: Measurement grid: $dx=8\text{mm}$, $dy=8\text{mm}$, $dz=5\text{mm}$

Reference Value = 20.116 V/m ; Power Drift = 0.04 dB

Peak SAR (extrapolated) = 0.595 mW/g

SAR(1 g) = 0.420 mW/g ; SAR(10 g) = 0.291 mW/g

Maximum value of SAR (measured) = 0.447 mW/g

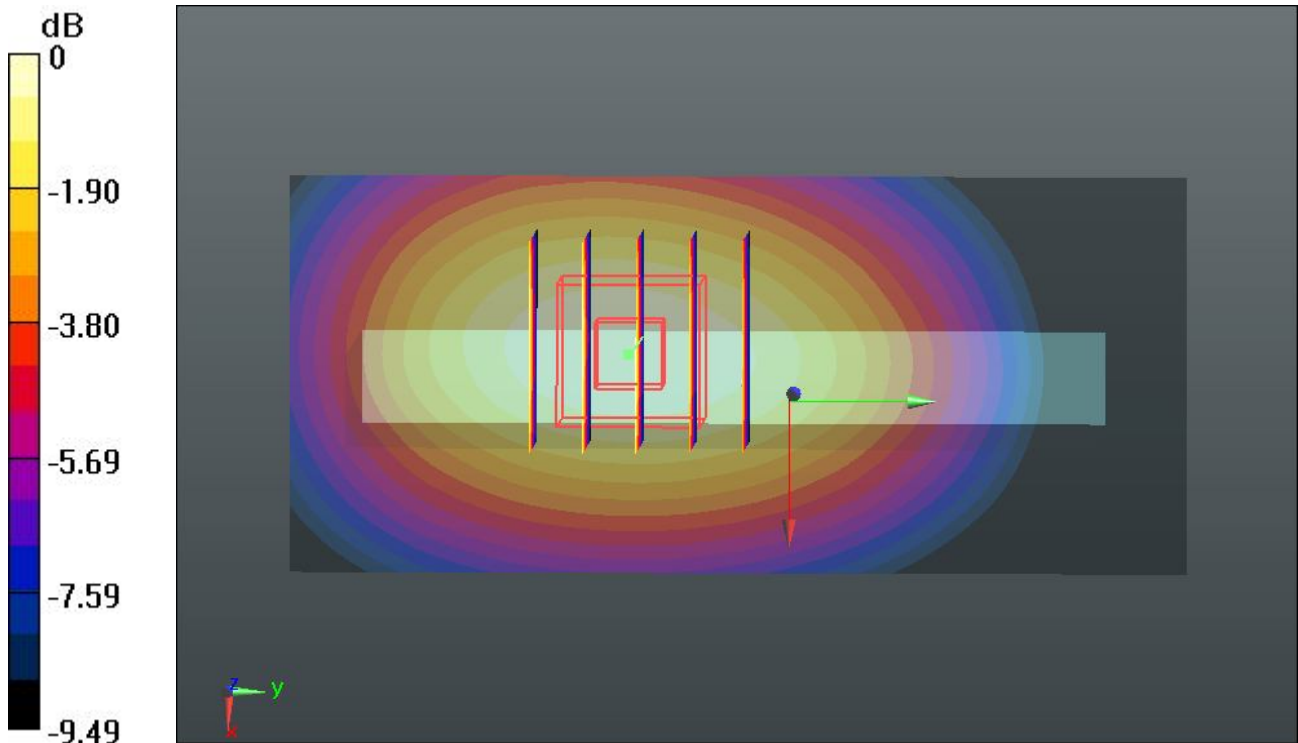

0 dB = 0.447 mW/g = -6.99 dB mW/g

56 WCDMA V_RMC 12.2K_Right Side_1cm_Ch4182

DUT: 251703

Communication System: UMTS; Frequency: 836.4 MHz; Duty Cycle: 1:1
 Medium: MSL_835_120806 Medium parameters used: $f = 836.4 \text{ MHz}$; $\sigma = 0.978 \text{ mho/m}$; $\epsilon_r = 54.378$; $\rho = 1000 \text{ kg/m}^3$
 Ambient Temperature : $23.7 \text{ }^\circ\text{C}$; Liquid Temperature : $21.4 \text{ }^\circ\text{C}$

DASY5 Configuration:

- Probe: ES3DV3 - SN3270; ConvF(6.16, 6.16, 6.16); Calibrated: 12.09.2011;
- Sensor-Surface: 4mm (Mechanical Surface Detection)
- Electronics: DAE4 Sn1303; Calibrated: 10.11.2011
- Phantom: SAM1; Type: QD000P40CD; Serial: TP:1670
- Measurement SW: DASY52, Version 52.8 (1); SEMCAD X Version 14.6.5 (6469)

Ch4182/Area Scan (41x91x1): Measurement grid: $dx=15\text{mm}$, $dy=15\text{mm}$
 Maximum value of SAR (interpolated) = 0.419 mW/g

Ch4182/Zoom Scan (5x5x7)/Cube 0: Measurement grid: $dx=8\text{mm}$, $dy=8\text{mm}$, $dz=5\text{mm}$
 Reference Value = 19.723 V/m ; Power Drift = 0.01 dB
 Peak SAR (extrapolated) = 0.564 mW/g
SAR(1 g) = 0.390 mW/g ; SAR(10 g) = 0.265 mW/g
 Maximum value of SAR (measured) = 0.415 mW/g

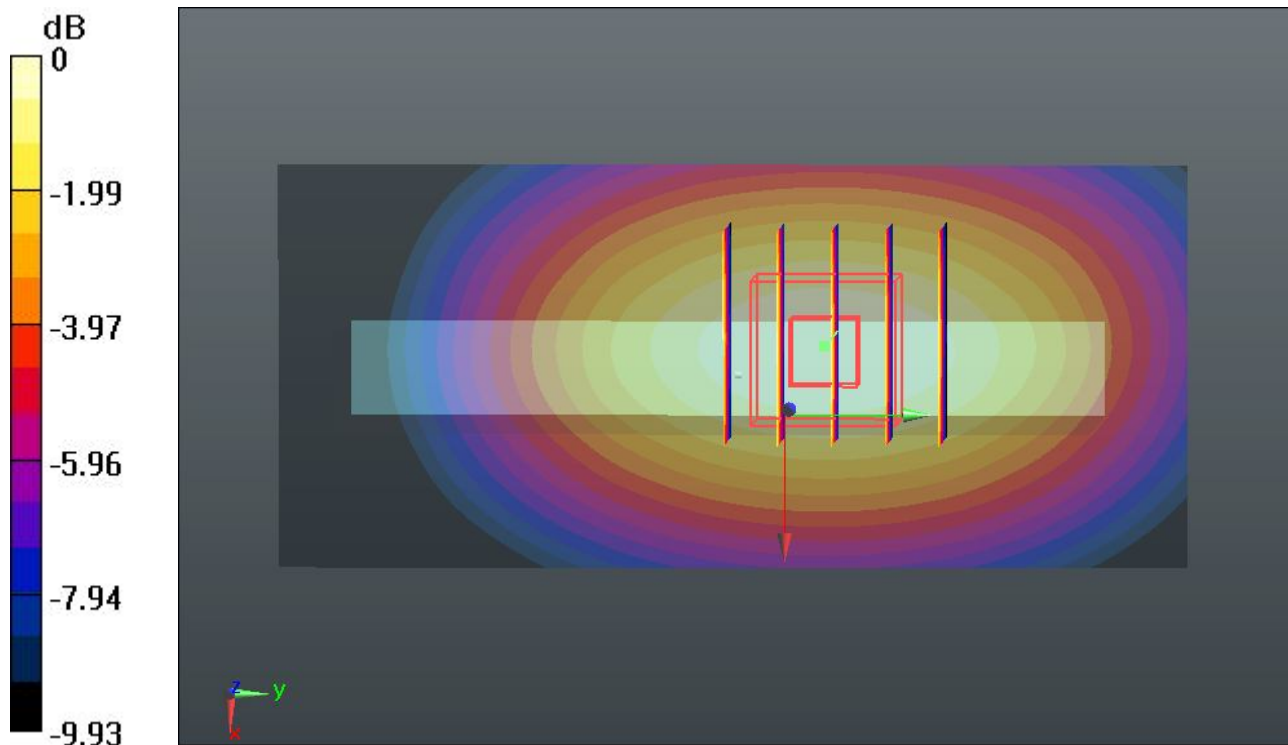

0 dB = 0.415 mW/g = -7.64 dB mW/g

57 WCDMA V_RMC 12.2K_Bottom Side_1cm_Ch4182

DUT: 251703

Communication System: UMTS; Frequency: 836.4 MHz; Duty Cycle: 1:1

Medium: MSL_835_120806 Medium parameters used: $f = 836.4 \text{ MHz}$; $\sigma = 0.978 \text{ mho/m}$; $\epsilon_r =$

54.378 ; $\rho = 1000 \text{ kg/m}^3$

Ambient Temperature : $23.7 \text{ }^\circ\text{C}$; Liquid Temperature : $21.4 \text{ }^\circ\text{C}$

DASY5 Configuration:

- Probe: ES3DV3 - SN3270; ConvF(6.16, 6.16, 6.16); Calibrated: 12.09.2011;
- Sensor-Surface: 4mm (Mechanical Surface Detection)
- Electronics: DAE4 Sn1303; Calibrated: 10.11.2011
- Phantom: SAM1; Type: QD000P40CD; Serial: TP:1670
- Measurement SW: DASY52, Version 52.8 (1); SEMCAD X Version 14.6.5 (6469)

Ch4182/Area Scan (41x61x1): Measurement grid: $dx=15\text{mm}$, $dy=15\text{mm}$

Maximum value of SAR (interpolated) = 0.0595 mW/g

Ch4182/Zoom Scan (5x5x7)/Cube 0: Measurement grid: $dx=8\text{mm}$, $dy=8\text{mm}$, $dz=5\text{mm}$

Reference Value = 6.433 V/m ; Power Drift = -0.01 dB

Peak SAR (extrapolated) = 0.089 mW/g

SAR(1 g) = 0.054 mW/g ; SAR(10 g) = 0.034 mW/g

Maximum value of SAR (measured) = 0.0574 mW/g

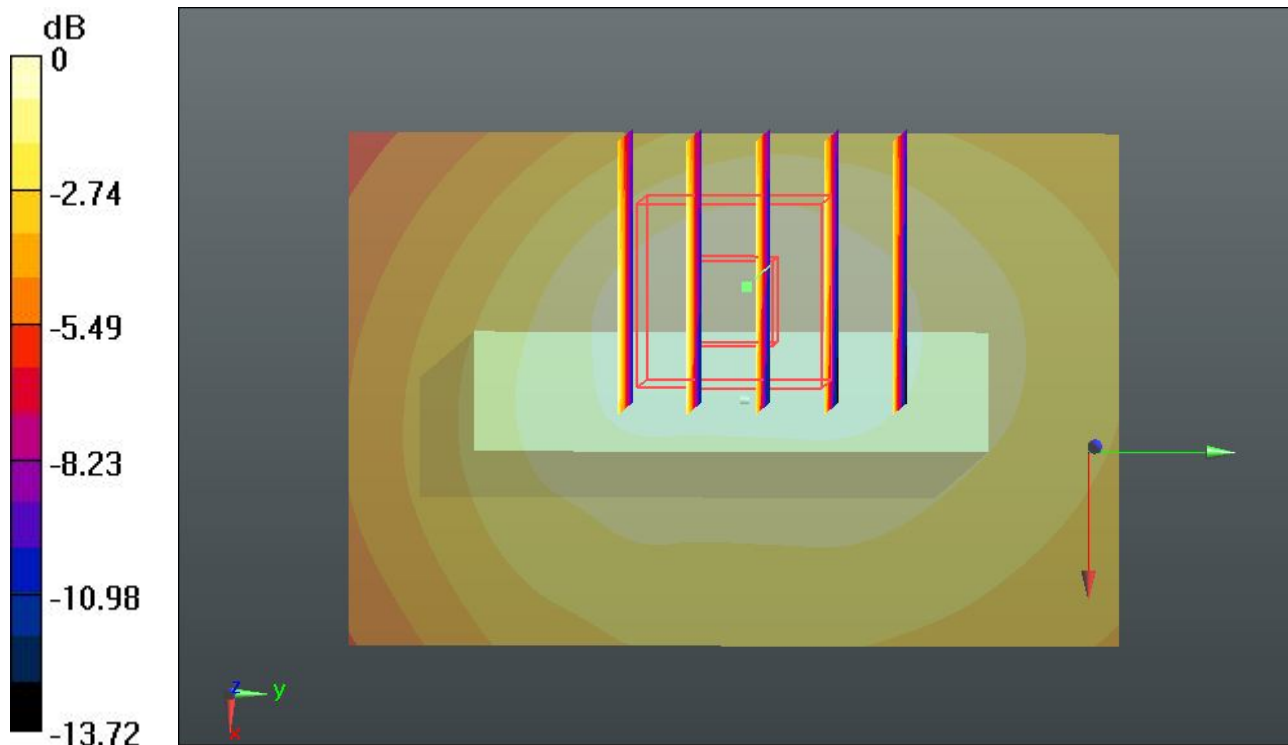

$0 \text{ dB} = 0.0574 \text{ mW/g} = -24.82 \text{ dB mW/g}$

58 WCDMA V_RMC 12.2K_Back_1cm_Ch4182_Headset

DUT: 251703

Communication System: UMTS; Frequency: 836.4 MHz; Duty Cycle: 1:1

Medium: MSL_835_120806 Medium parameters used: $f = 836.4$ MHz; $\sigma = 0.978$ mho/m; $\epsilon_r =$

54.378; $\rho = 1000$ kg/m³

Ambient Temperature : 23.7 °C ; Liquid Temperature : 21.4 °C

DASY5 Configuration:

- Probe: ES3DV3 - SN3270; ConvF(6.16, 6.16, 6.16); Calibrated: 12.09.2011;
- Sensor-Surface: 4mm (Mechanical Surface Detection)
- Electronics: DAE4 Sn1303; Calibrated: 10.11.2011
- Phantom: SAM1; Type: QD000P40CD; Serial: TP:1670
- Measurement SW: DASY52, Version 52.8 (1); SEMCAD X Version 14.6.5 (6469)

Ch4182/Area Scan (61x91x1): Measurement grid: dx=15mm, dy=15mm

Maximum value of SAR (interpolated) = 0.528 mW/g

Ch4182/Zoom Scan (5x5x7)/Cube 1: Measurement grid: dx=8mm, dy=8mm, dz=5mm

Reference Value = 19.810 V/m; Power Drift = -0.02 dB

Peak SAR (extrapolated) = 0.667 mW/g

SAR(1 g) = 0.494 mW/g; SAR(10 g) = 0.356 mW/g

Maximum value of SAR (measured) = 0.519 mW/g

Ch4182/Zoom Scan (5x5x7)/Cube 0: Measurement grid: dx=8mm, dy=8mm, dz=5mm

Reference Value = 19.810 V/m; Power Drift = -0.02 dB

Peak SAR (extrapolated) = 0.703 mW/g

SAR(1 g) = 0.468 mW/g; SAR(10 g) = 0.329 mW/g

Maximum value of SAR (measured) = 0.506 mW/g

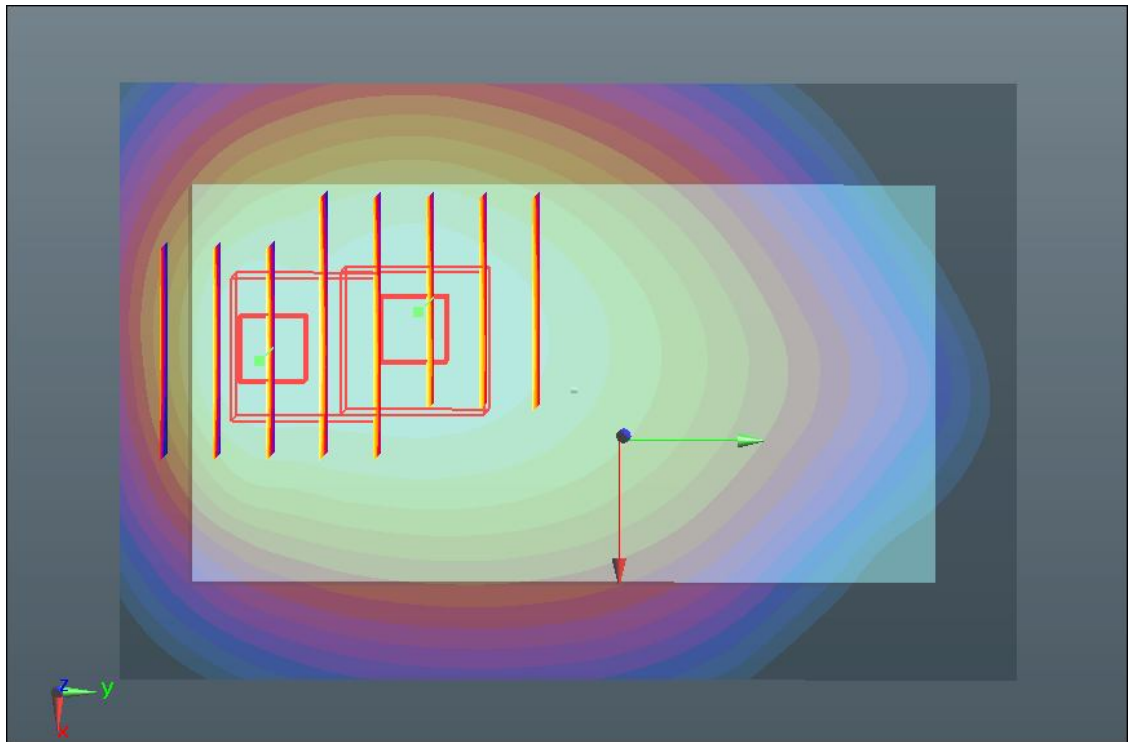
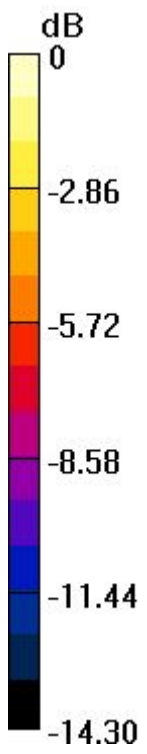

0 dB = 0.506 mW/g = -5.92 dB mW/g

31 WCDMA II_RMC 12.2K_Front_1cm_Ch9538

DUT: 251703

Communication System: UMTS; Frequency: 1907.6 MHz; Duty Cycle: 1:1

Medium: MSL_1900_120806 Medium parameters used: $f = 1908 \text{ MHz}$; $\sigma = 1.527 \text{ mho/m}$; $\epsilon_r =$

53.556 ; $\rho = 1000 \text{ kg/m}^3$

Ambient Temperature : $23.5 \text{ }^\circ\text{C}$; Liquid Temperature : $21.5 \text{ }^\circ\text{C}$

DASY5 Configuration:

- Probe: ES3DV3 - SN3270; ConvF(4.64, 4.64, 4.64); Calibrated: 12.09.2011;
- Sensor-Surface: 4mm (Mechanical Surface Detection)
- Electronics: DAE4 Sn1303; Calibrated: 10.11.2011
- Phantom: SAM2; Type: QD000P40CD; Serial: TP:1671
- Measurement SW: DASY52, Version 52.8 (1); SEMCAD X Version 14.6.5 (6469)

Ch9538/Area Scan (61x91x1): Measurement grid: $dx=15\text{mm}$, $dy=15\text{mm}$

Maximum value of SAR (interpolated) = 0.662 mW/g

Ch9538/Zoom Scan (5x5x7)/Cube 0: Measurement grid: $dx=8\text{mm}$, $dy=8\text{mm}$, $dz=5\text{mm}$

Reference Value = 12.443 V/m ; Power Drift = -0.06 dB

Peak SAR (extrapolated) = 0.959 mW/g

SAR(1 g) = 0.582 mW/g ; SAR(10 g) = 0.354 mW/g

Maximum value of SAR (measured) = 0.628 mW/g

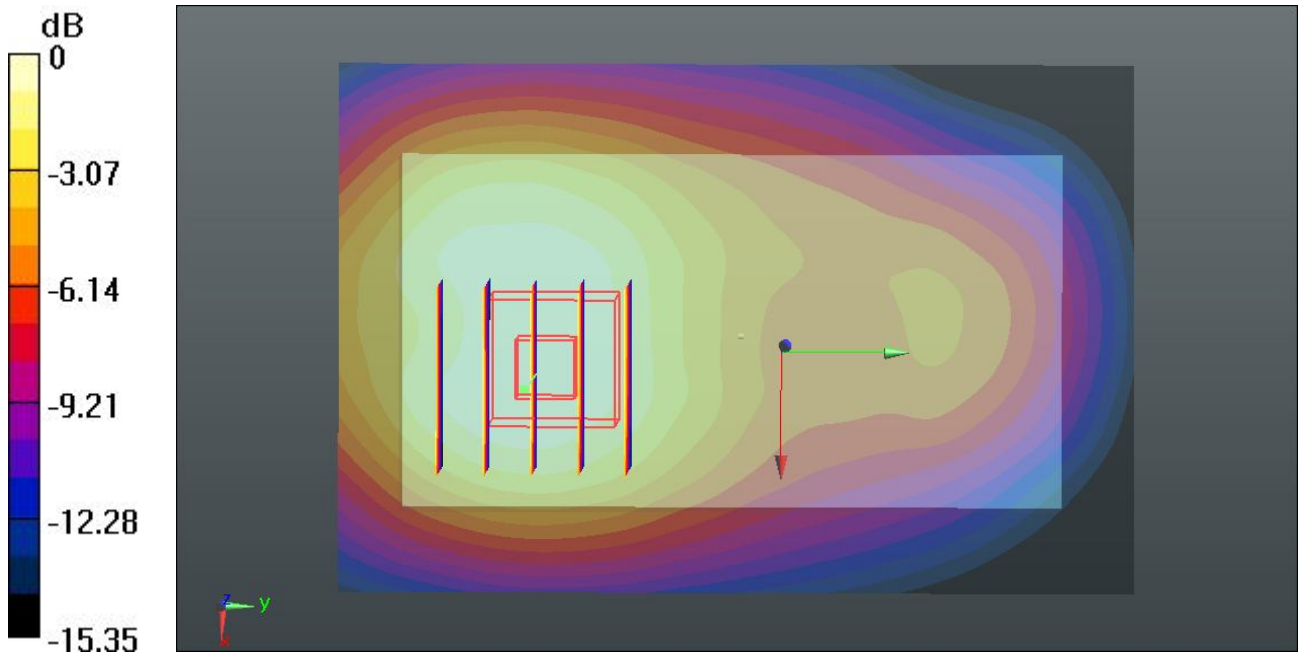

$0 \text{ dB} = 0.628 \text{ mW/g} = -4.04 \text{ dB mW/g}$

32 WCDMA II_RMC 12.2K_Back_1cm_Ch9538

DUT: 251703

Communication System: UMTS; Frequency: 1907.6 MHz; Duty Cycle: 1:1

Medium: MSL_1900_120806 Medium parameters used: $f = 1908 \text{ MHz}$; $\sigma = 1.527 \text{ mho/m}$; $\epsilon_r =$

53.556 ; $\rho = 1000 \text{ kg/m}^3$

Ambient Temperature : $23.5 \text{ }^\circ\text{C}$; Liquid Temperature : $21.5 \text{ }^\circ\text{C}$

DASY5 Configuration:

- Probe: ES3DV3 - SN3270; ConvF(4.64, 4.64, 4.64); Calibrated: 12.09.2011;
- Sensor-Surface: 4mm (Mechanical Surface Detection)
- Electronics: DAE4 Sn1303; Calibrated: 10.11.2011
- Phantom: SAM2; Type: QD000P40CD; Serial: TP:1671
- Measurement SW: DASY52, Version 52.8 (1); SEMCAD X Version 14.6.5 (6469)

Ch9538/Area Scan (61x91x1): Measurement grid: $dx=15\text{mm}$, $dy=15\text{mm}$

Maximum value of SAR (interpolated) = 0.721 mW/g

Ch9538/Zoom Scan (5x5x7)/Cube 0: Measurement grid: $dx=8\text{mm}$, $dy=8\text{mm}$, $dz=5\text{mm}$

Reference Value = 13.546 V/m ; Power Drift = -0.02 dB

Peak SAR (extrapolated) = 1.129 mW/g

SAR(1 g) = 0.665 mW/g ; SAR(10 g) = 0.399 mW/g

Maximum value of SAR (measured) = 0.709 mW/g

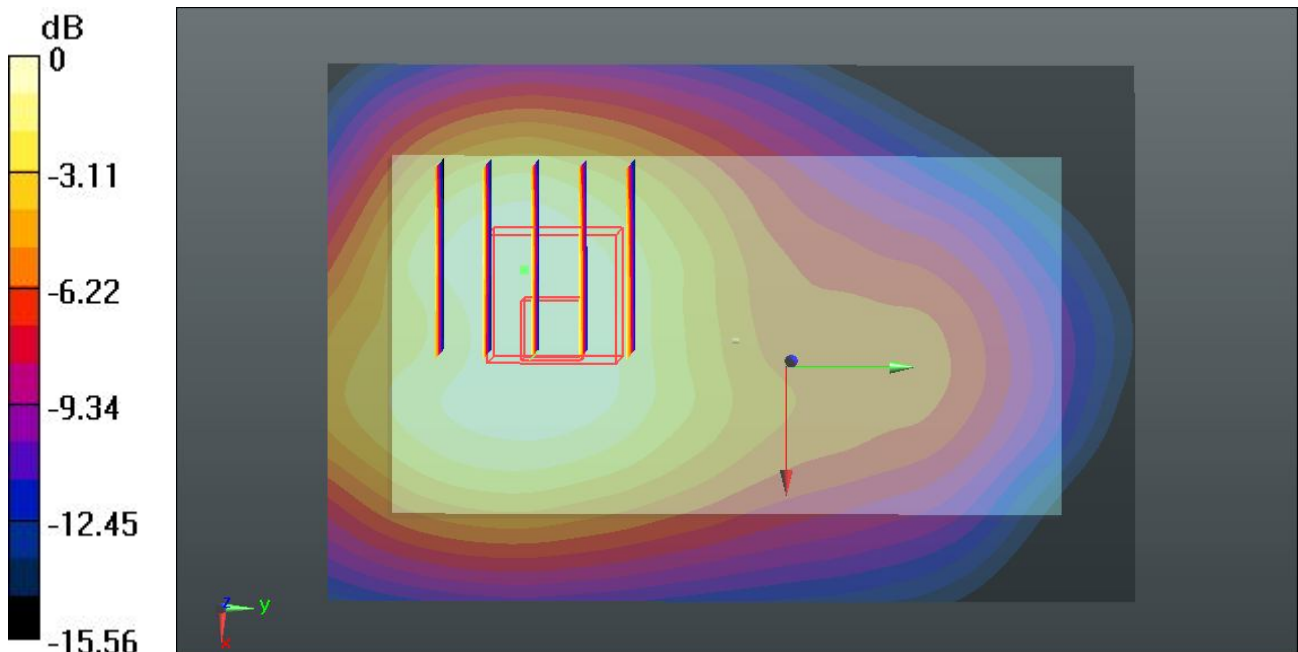

$0 \text{ dB} = 0.709 \text{ mW/g} = -2.99 \text{ dB mW/g}$

32 WCDMA II_RMC 12.2K_Back_1cm_Ch9538_2D

DUT: 251703

Communication System: UMTS; Frequency: 1907.6 MHz; Duty Cycle: 1:1

Medium: MSL_1900_120806 Medium parameters used: $f = 1908 \text{ MHz}$; $\sigma = 1.527 \text{ mho/m}$; $\epsilon_r = 53.556$; $\rho = 1000 \text{ kg/m}^3$

Ambient Temperature : $23.5 \text{ }^\circ\text{C}$; Liquid Temperature : $21.5 \text{ }^\circ\text{C}$

DASY5 Configuration:

- Probe: ES3DV3 - SN3270; ConvF(4.64, 4.64, 4.64); Calibrated: 12.09.2011;
- Sensor-Surface: 4mm (Mechanical Surface Detection)
- Electronics: DAE4 Sn1303; Calibrated: 10.11.2011
- Phantom: SAM2; Type: QD000P40CD; Serial: TP:1671
- Measurement SW: DASY52, Version 52.8 (1); SEMCAD X Version 14.6.5 (6469)

Ch9538/Area Scan (61x91x1): Measurement grid: $dx=15\text{mm}$, $dy=15\text{mm}$

Maximum value of SAR (interpolated) = 0.721 mW/g

Ch9538/Zoom Scan (5x5x7)/Cube 0: Measurement grid: $dx=8\text{mm}$, $dy=8\text{mm}$, $dz=5\text{mm}$

Reference Value = 13.546 V/m ; Power Drift = -0.02 dB

Peak SAR (extrapolated) = 1.129 mW/g

SAR(1 g) = 0.665 mW/g ; SAR(10 g) = 0.399 mW/g

Maximum value of SAR (measured) = 0.709 mW/g

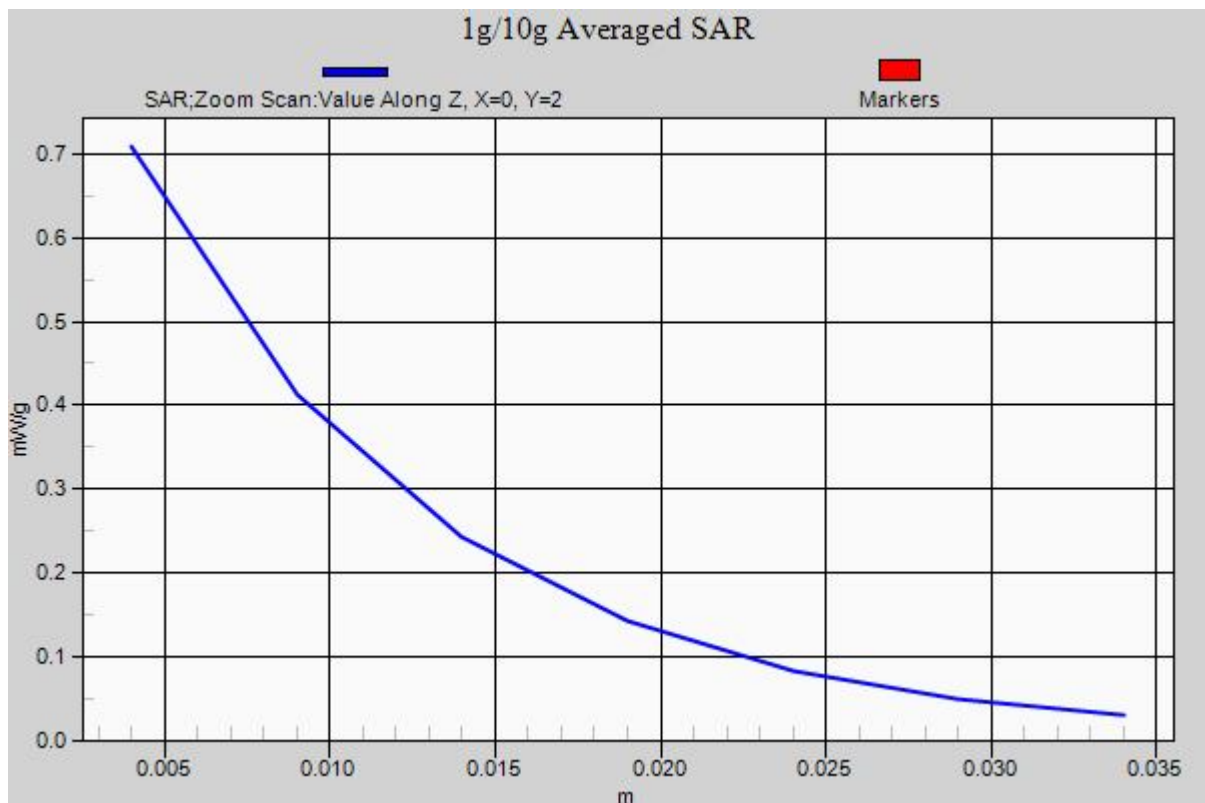

33 WCDMA II_RMC 12.2K_Left Side_1cm_Ch9538

DUT: 251703

Communication System: UMTS; Frequency: 1907.6 MHz; Duty Cycle: 1:1

Medium: MSL_1900_120806 Medium parameters used: $f = 1908 \text{ MHz}$; $\sigma = 1.527 \text{ mho/m}$; $\epsilon_r =$

53.556 ; $\rho = 1000 \text{ kg/m}^3$

Ambient Temperature : $23.5 \text{ }^\circ\text{C}$; Liquid Temperature : $21.5 \text{ }^\circ\text{C}$

DASY5 Configuration:

- Probe: ES3DV3 - SN3270; ConvF(4.64, 4.64, 4.64); Calibrated: 12.09.2011;
- Sensor-Surface: 4mm (Mechanical Surface Detection)
- Electronics: DAE4 Sn1303; Calibrated: 10.11.2011
- Phantom: SAM2; Type: QD000P40CD; Serial: TP:1671
- Measurement SW: DASY52, Version 52.8 (1); SEMCAD X Version 14.6.5 (6469)

Ch9538/Area Scan (41x91x1): Measurement grid: $dx=15\text{mm}$, $dy=15\text{mm}$

Maximum value of SAR (interpolated) = 0.191 mW/g

Ch9538/Zoom Scan (5x5x7)/Cube 0: Measurement grid: $dx=8\text{mm}$, $dy=8\text{mm}$, $dz=5\text{mm}$

Reference Value = 9.825 V/m ; Power Drift = 0.07 dB

Peak SAR (extrapolated) = 0.286 mW/g

SAR(1 g) = 0.178 mW/g ; SAR(10 g) = 0.108 mW/g

Maximum value of SAR (measured) = 0.194 mW/g

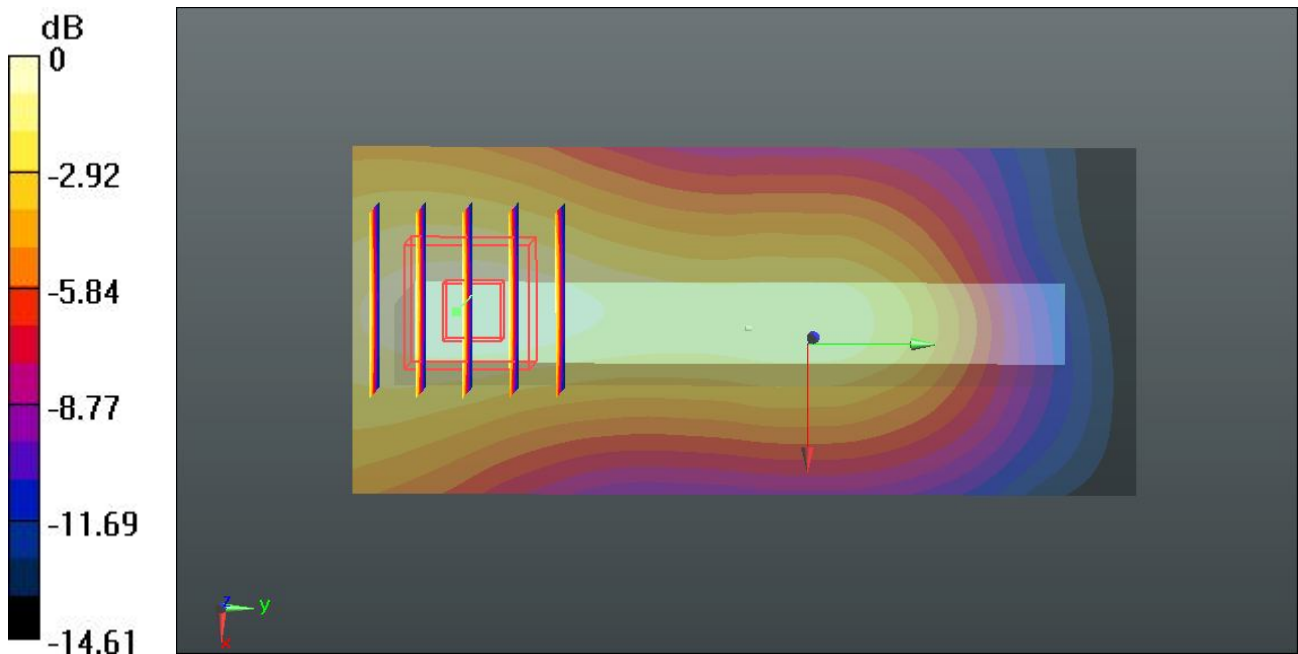

$0 \text{ dB} = 0.194 \text{ mW/g} = -14.24 \text{ dB mW/g}$

34 WCDMA II_RMC 12.2K_Right Side_1cm_Ch9538

DUT: 251703

Communication System: UMTS; Frequency: 1907.6 MHz; Duty Cycle: 1:1

Medium: MSL_1900_120806 Medium parameters used: $f = 1908 \text{ MHz}$; $\sigma = 1.527 \text{ mho/m}$; $\epsilon_r =$

53.556 ; $\rho = 1000 \text{ kg/m}^3$

Ambient Temperature : $23.5 \text{ }^\circ\text{C}$; Liquid Temperature : $21.5 \text{ }^\circ\text{C}$

DASY5 Configuration:

- Probe: ES3DV3 - SN3270; ConvF(4.64, 4.64, 4.64); Calibrated: 12.09.2011;
- Sensor-Surface: 4mm (Mechanical Surface Detection)
- Electronics: DAE4 Sn1303; Calibrated: 10.11.2011
- Phantom: SAM2; Type: QD000P40CD; Serial: TP:1671
- Measurement SW: DASY52, Version 52.8 (1); SEMCAD X Version 14.6.5 (6469)

Ch9538/Area Scan (41x91x1): Measurement grid: $dx=15\text{mm}$, $dy=15\text{mm}$

Maximum value of SAR (interpolated) = 0.173 mW/g

Ch9538/Zoom Scan (5x5x7)/Cube 0: Measurement grid: $dx=8\text{mm}$, $dy=8\text{mm}$, $dz=5\text{mm}$

Reference Value = 10.772 V/m ; Power Drift = -0.05 dB

Peak SAR (extrapolated) = 0.254 mW/g

SAR(1 g) = 0.157 mW/g ; SAR(10 g) = 0.095 mW/g

Maximum value of SAR (measured) = 0.170 mW/g

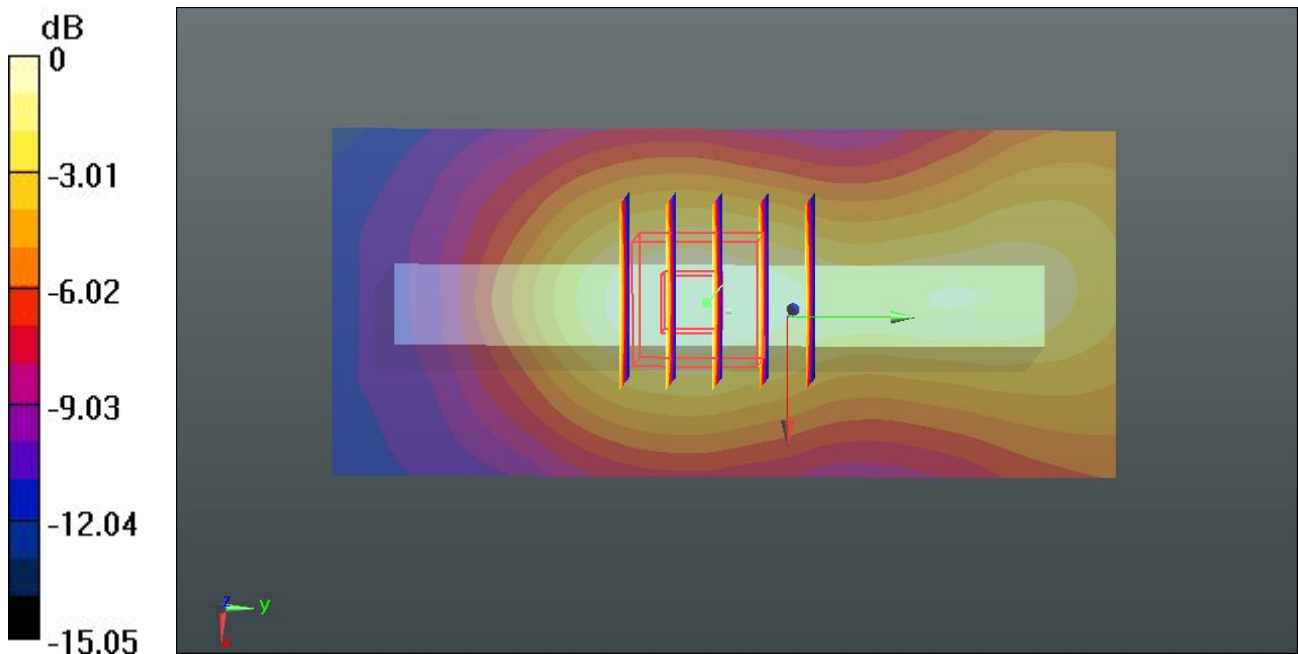

$0 \text{ dB} = 0.170 \text{ mW/g} = -15.39 \text{ dB mW/g}$

35 WCDMA II_RMC 12.2K_Bottom Side_1cm_Ch9538

DUT: 251703

Communication System: UMTS; Frequency: 1907.6 MHz; Duty Cycle: 1:1

Medium: MSL_1900_120806 Medium parameters used: $f = 1908 \text{ MHz}$; $\sigma = 1.527 \text{ mho/m}$; $\epsilon_r =$

53.556 ; $\rho = 1000 \text{ kg/m}^3$

Ambient Temperature : $23.5 \text{ }^\circ\text{C}$; Liquid Temperature : $21.5 \text{ }^\circ\text{C}$

DASY5 Configuration:

- Probe: ES3DV3 - SN3270; ConvF(4.64, 4.64, 4.64); Calibrated: 12.09.2011;
- Sensor-Surface: 4mm (Mechanical Surface Detection)
- Electronics: DAE4 Sn1303; Calibrated: 10.11.2011
- Phantom: SAM2; Type: QD000P40CD; Serial: TP:1671
- Measurement SW: DASY52, Version 52.8 (1); SEMCAD X Version 14.6.5 (6469)

Ch9538/Area Scan (41x61x1): Measurement grid: $dx=15\text{mm}$, $dy=15\text{mm}$

Maximum value of SAR (interpolated) = 0.539 mW/g

Ch9538/Zoom Scan (5x5x7)/Cube 0: Measurement grid: $dx=8\text{mm}$, $dy=8\text{mm}$, $dz=5\text{mm}$

Reference Value = 11.866 V/m ; Power Drift = -0.09 dB

Peak SAR (extrapolated) = 0.794 mW/g

SAR(1 g) = 0.479 mW/g ; SAR(10 g) = 0.263 mW/g

Maximum value of SAR (measured) = 0.542 mW/g

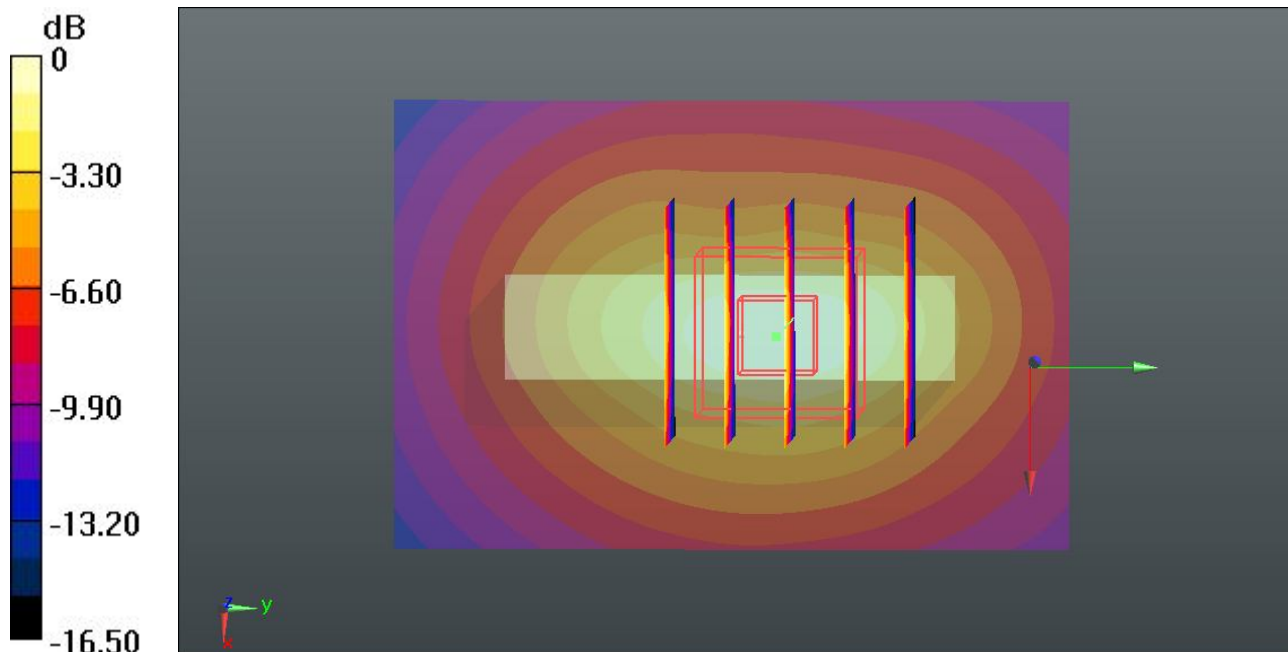

$0 \text{ dB} = 0.542 \text{ mW/g} = -5.32 \text{ dB mW/g}$

36 WCDMA II_RMC 12.2K_Back_1cm_Ch9538_Headset

DUT: 251703

Communication System: UMTS; Frequency: 1907.6 MHz; Duty Cycle: 1:1

Medium: MSL_1900_120806 Medium parameters used: $f = 1908 \text{ MHz}$; $\sigma = 1.527 \text{ mho/m}$; $\epsilon_r =$

53.556 ; $\rho = 1000 \text{ kg/m}^3$

Ambient Temperature : $23.5 \text{ }^\circ\text{C}$; Liquid Temperature : $21.5 \text{ }^\circ\text{C}$

DASY5 Configuration:

- Probe: ES3DV3 - SN3270; ConvF(4.64, 4.64, 4.64); Calibrated: 12.09.2011;
- Sensor-Surface: 4mm (Mechanical Surface Detection)
- Electronics: DAE4 Sn1303; Calibrated: 10.11.2011
- Phantom: SAM2; Type: QD000P40CD; Serial: TP:1671
- Measurement SW: DASY52, Version 52.8 (1); SEMCAD X Version 14.6.5 (6469)

Ch9538/Area Scan (61x91x1): Measurement grid: $dx=15\text{mm}$, $dy=15\text{mm}$

Maximum value of SAR (interpolated) = 0.677 mW/g

Ch9538/Zoom Scan (5x5x7)/Cube 0: Measurement grid: $dx=8\text{mm}$, $dy=8\text{mm}$, $dz=5\text{mm}$

Reference Value = 13.016 V/m ; Power Drift = -0.01 dB

Peak SAR (extrapolated) = 1.065 mW/g

SAR(1 g) = 0.620 mW/g ; SAR(10 g) = 0.374 mW/g

Maximum value of SAR (measured) = 0.655 mW/g

Ch9538/Zoom Scan (5x5x7)/Cube 1: Measurement grid: $dx=8\text{mm}$, $dy=8\text{mm}$, $dz=5\text{mm}$

Reference Value = 13.016 V/m ; Power Drift = -0.01 dB

Peak SAR (extrapolated) = 1.032 mW/g

SAR(1 g) = 0.618 mW/g ; SAR(10 g) = 0.370 mW/g

Maximum value of SAR (measured) = 0.660 mW/g

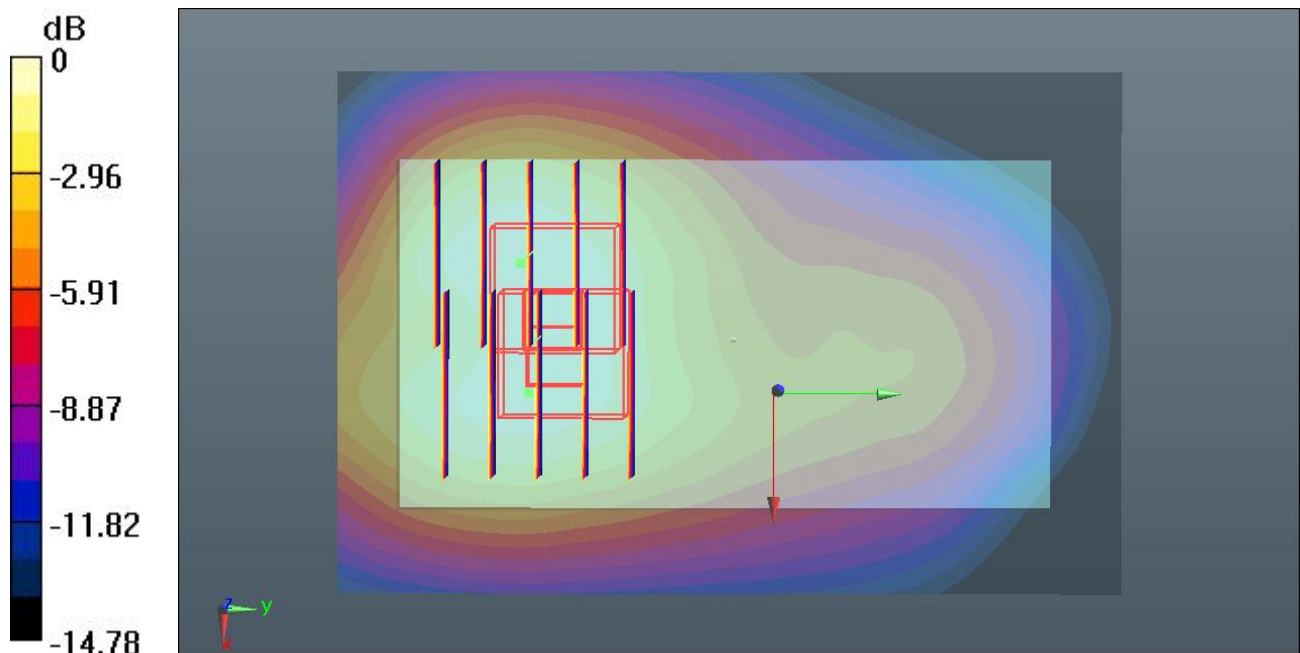

0 dB = 0.660 mW/g = -3.61 dB mW/g

59 802.11b_Front_1cm_Ch1

DUT: 251703

Communication System: WIFI; Frequency: 2412 MHz; Duty Cycle: 1:1

Medium: MSL_2450_120807 Medium parameters used: $f = 2412 \text{ MHz}$; $\sigma = 1.883 \text{ mho/m}$; $\epsilon_r =$

53.971 ; $\rho = 1000 \text{ kg/m}^3$

Ambient Temperature : $23.5 \text{ }^\circ\text{C}$; Liquid Temperature : $21.6 \text{ }^\circ\text{C}$

DASY5 Configuration:

- Probe: ES3DV3 - SN3270; ConvF(4.28, 4.28, 4.28); Calibrated: 12.09.2011;
- Sensor-Surface: 4mm (Mechanical Surface Detection)
- Electronics: DAE4 Sn1303; Calibrated: 10.11.2011
- Phantom: SAM2; Type: QD000P40CD; Serial: TP:1671
- Measurement SW: DASY52, Version 52.8 (1); SEMCAD X Version 14.6.5 (6469)

Ch1/Area Scan (61x91x1): Measurement grid: $dx=15\text{mm}$, $dy=15\text{mm}$

Maximum value of SAR (interpolated) = 0.0312 mW/g

Ch1/Zoom Scan (5x5x7)/Cube 0: Measurement grid: $dx=8\text{mm}$, $dy=8\text{mm}$, $dz=5\text{mm}$

Reference Value = 2.533 V/m ; Power Drift = 0.04 dB

Peak SAR (extrapolated) = 0.049 mW/g

SAR(1 g) = 0.028 mW/g ; SAR(10 g) = 0.016 mW/g

Maximum value of SAR (measured) = 0.0292 mW/g

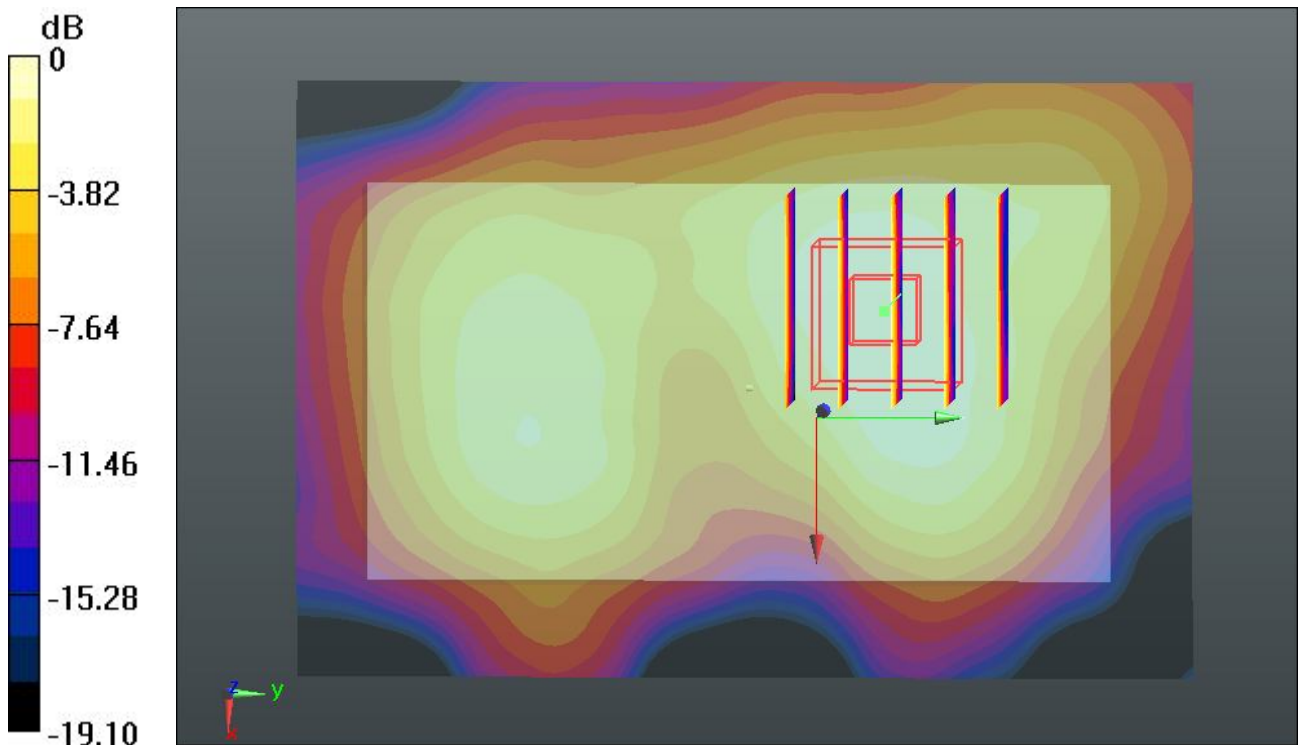

$0 \text{ dB} = 0.0292 \text{ mW/g} = -30.69 \text{ dB mW/g}$

60 802.11b_Back_1cm_Ch1

DUT: 251703

Communication System: WIFI; Frequency: 2412 MHz; Duty Cycle: 1:1

Medium: MSL_2450_120807 Medium parameters used: $f = 2412 \text{ MHz}$; $\sigma = 1.883 \text{ mho/m}$; $\epsilon_r =$

53.971 ; $\rho = 1000 \text{ kg/m}^3$

Ambient Temperature : $23.5 \text{ }^\circ\text{C}$; Liquid Temperature : $21.6 \text{ }^\circ\text{C}$

DASY5 Configuration:

- Probe: ES3DV3 - SN3270; ConvF(4.28, 4.28, 4.28); Calibrated: 12.09.2011;
- Sensor-Surface: 4mm (Mechanical Surface Detection)
- Electronics: DAE4 Sn1303; Calibrated: 10.11.2011
- Phantom: SAM2; Type: QD000P40CD; Serial: TP:1671
- Measurement SW: DASY52, Version 52.8 (1); SEMCAD X Version 14.6.5 (6469)

Ch1/Area Scan (61x91x1): Measurement grid: $dx=15\text{mm}$, $dy=15\text{mm}$

Maximum value of SAR (interpolated) = 0.0550 mW/g

Ch1/Zoom Scan (5x5x7)/Cube 0: Measurement grid: $dx=8\text{mm}$, $dy=8\text{mm}$, $dz=5\text{mm}$

Reference Value = 3.639 V/m ; Power Drift = 0.13 dB

Peak SAR (extrapolated) = 0.096 mW/g

SAR(1 g) = 0.052 mW/g ; SAR(10 g) = 0.029 mW/g

Maximum value of SAR (measured) = 0.0557 mW/g

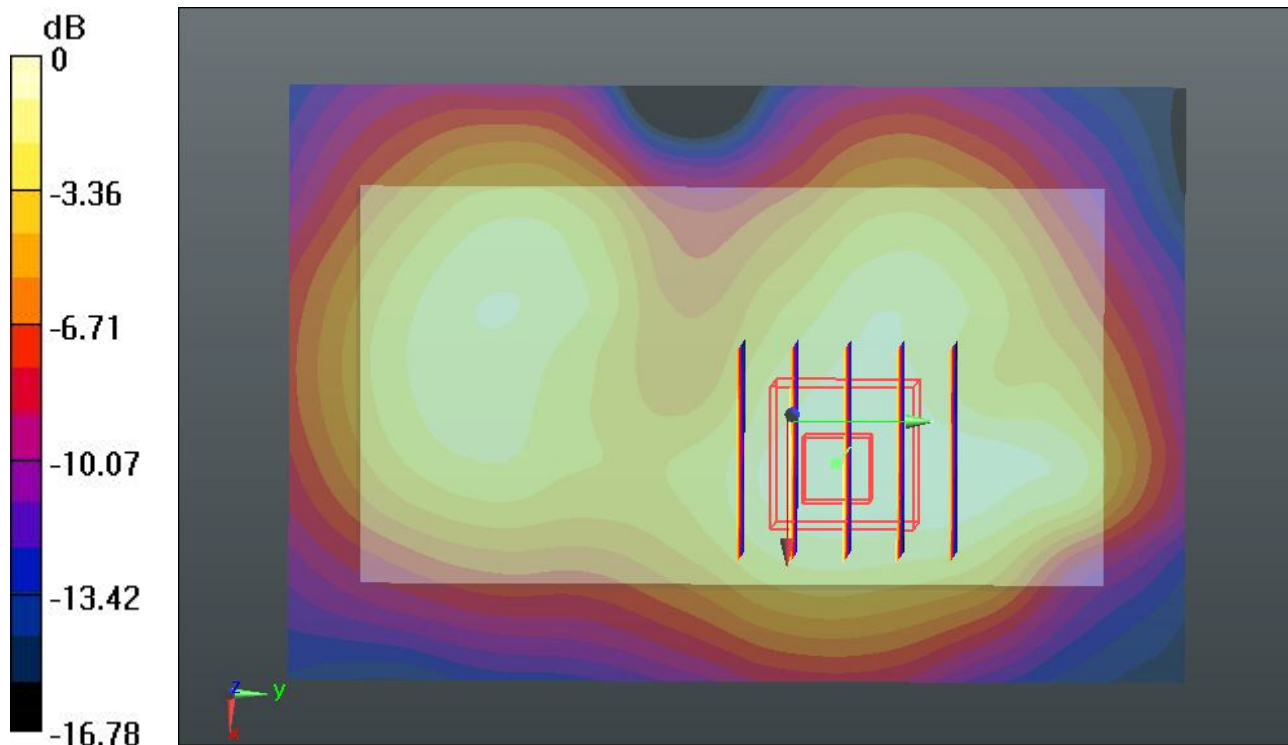

$0 \text{ dB} = 0.0557 \text{ mW/g} = -25.08 \text{ dB mW/g}$

60 802.11b_Back_1cm_Ch1_2D

DUT: 251703

Communication System: WIFI; Frequency: 2412 MHz; Duty Cycle: 1:1

Medium: MSL_2450_120807 Medium parameters used: $f = 2412 \text{ MHz}$; $\sigma = 1.883 \text{ mho/m}$; $\epsilon_r =$

53.971 ; $\rho = 1000 \text{ kg/m}^3$

Ambient Temperature : $23.5 \text{ }^\circ\text{C}$; Liquid Temperature : $21.6 \text{ }^\circ\text{C}$

DASY5 Configuration:

- Probe: ES3DV3 - SN3270; ConvF(4.28, 4.28, 4.28); Calibrated: 12.09.2011;
- Sensor-Surface: 4mm (Mechanical Surface Detection)
- Electronics: DAE4 Sn1303; Calibrated: 10.11.2011
- Phantom: SAM2; Type: QD000P40CD; Serial: TP:1671
- Measurement SW: DASY52, Version 52.8 (1); SEMCAD X Version 14.6.5 (6469)

Ch1/Area Scan (61x91x1): Measurement grid: $dx=15\text{mm}$, $dy=15\text{mm}$

Maximum value of SAR (interpolated) = 0.0550 mW/g

Ch1/Zoom Scan (5x5x7)/Cube 0: Measurement grid: $dx=8\text{mm}$, $dy=8\text{mm}$, $dz=5\text{mm}$

Reference Value = 3.639 V/m ; Power Drift = 0.13 dB

Peak SAR (extrapolated) = 0.096 mW/g

SAR(1 g) = 0.052 mW/g ; SAR(10 g) = 0.029 mW/g

Maximum value of SAR (measured) = 0.0557 mW/g

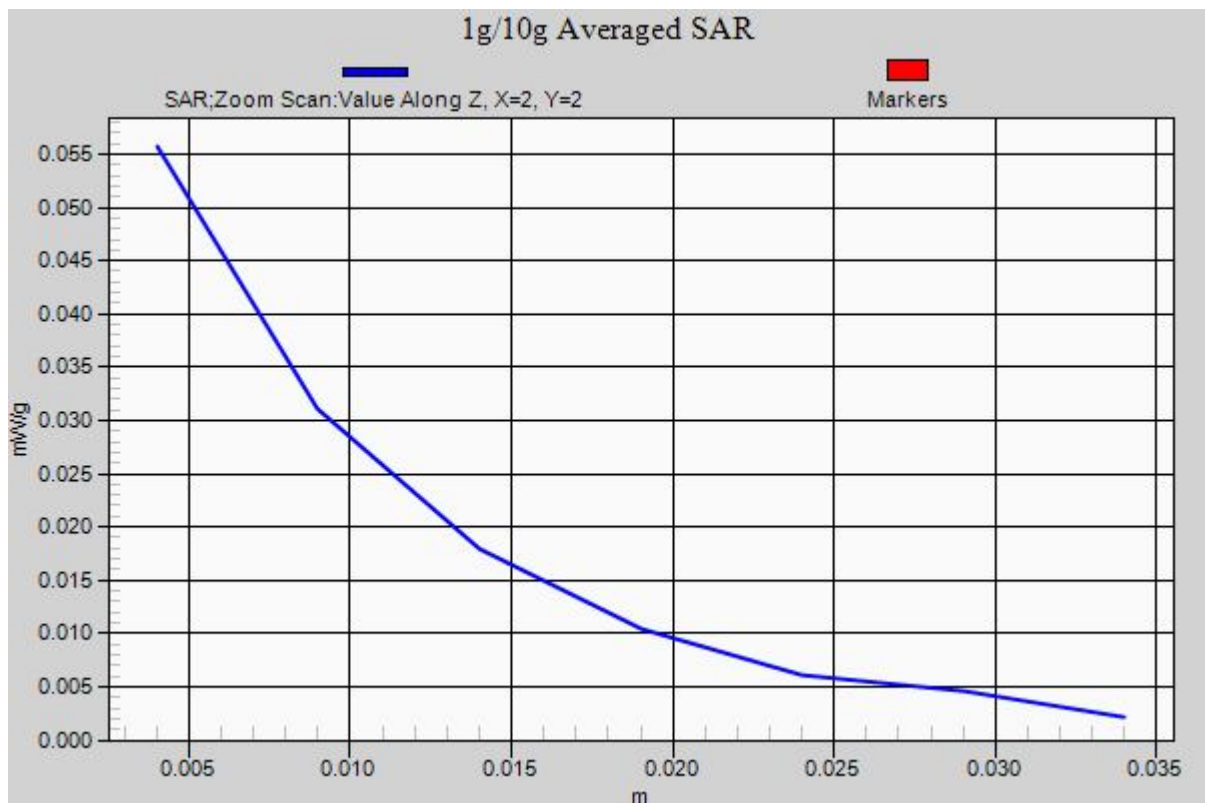

61 802.11b_Left Side_1cm_Ch1

DUT: 251703

Communication System: WIFI; Frequency: 2412 MHz; Duty Cycle: 1:1

Medium: MSL_2450_120807 Medium parameters used: $f = 2412 \text{ MHz}$; $\sigma = 1.883 \text{ mho/m}$; $\epsilon_r = 53.971$; $\rho = 1000 \text{ kg/m}^3$

Ambient Temperature : $23.5 \text{ }^\circ\text{C}$; Liquid Temperature : $21.6 \text{ }^\circ\text{C}$

DASY5 Configuration:

- Probe: ES3DV3 - SN3270; ConvF(4.28, 4.28, 4.28); Calibrated: 12.09.2011;
- Sensor-Surface: 4mm (Mechanical Surface Detection)
- Electronics: DAE4 Sn1303; Calibrated: 10.11.2011
- Phantom: SAM2; Type: QD000P40CD; Serial: TP:1671
- Measurement SW: DASY52, Version 52.8 (1); SEMCAD X Version 14.6.5 (6469)

Ch1/Area Scan (41x91x1): Measurement grid: $dx=15\text{mm}$, $dy=15\text{mm}$

Maximum value of SAR (interpolated) = 0.0379 mW/g

Ch1/Zoom Scan (5x5x7)/Cube 0: Measurement grid: $dx=8\text{mm}$, $dy=8\text{mm}$, $dz=5\text{mm}$

Reference Value = 3.668 V/m ; Power Drift = 0.14 dB

Peak SAR (extrapolated) = 0.070 mW/g

SAR(1 g) = 0.034 mW/g ; SAR(10 g) = 0.018 mW/g

Maximum value of SAR (measured) = 0.0372 mW/g

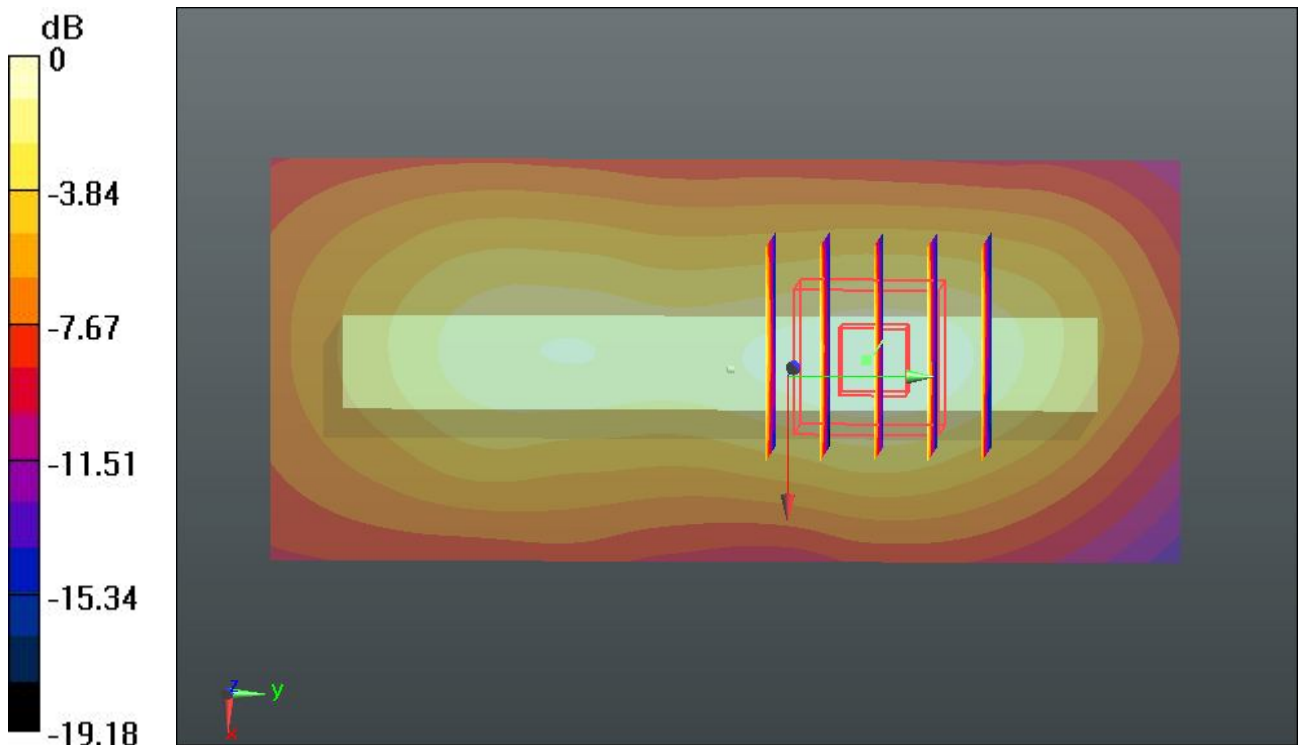

0 dB = $0.0372 \text{ mW/g} = -28.59 \text{ dB mW/g}$

62 802.11b_Top Side_1cm_Ch1

DUT: 251703

Communication System: WIFI; Frequency: 2412 MHz; Duty Cycle: 1:1

Medium: MSL_2450_120807 Medium parameters used: $f = 2412 \text{ MHz}$; $\sigma = 1.883 \text{ mho/m}$; $\epsilon_r =$

53.971 ; $\rho = 1000 \text{ kg/m}^3$

Ambient Temperature : $23.5 \text{ }^\circ\text{C}$; Liquid Temperature : $21.6 \text{ }^\circ\text{C}$

DASY5 Configuration:

- Probe: ES3DV3 - SN3270; ConvF(4.28, 4.28, 4.28); Calibrated: 12.09.2011;
- Sensor-Surface: 4mm (Mechanical Surface Detection)
- Electronics: DAE4 Sn1303; Calibrated: 10.11.2011
- Phantom: SAM2; Type: QD000P40CD; Serial: TP:1671
- Measurement SW: DASY52, Version 52.8 (1); SEMCAD X Version 14.6.5 (6469)

Ch1/Area Scan (41x61x1): Measurement grid: $dx=15\text{mm}$, $dy=15\text{mm}$

Maximum value of SAR (interpolated) = 0.0262 mW/g

Ch1/Zoom Scan (5x5x7)/Cube 0: Measurement grid: $dx=8\text{mm}$, $dy=8\text{mm}$, $dz=5\text{mm}$

Reference Value = 1.592 V/m ; Power Drift = -0.03 dB

Peak SAR (extrapolated) = 0.047 mW/g

SAR(1 g) = 0.023 mW/g ; SAR(10 g) = 0.011 mW/g

Maximum value of SAR (measured) = 0.0268 mW/g

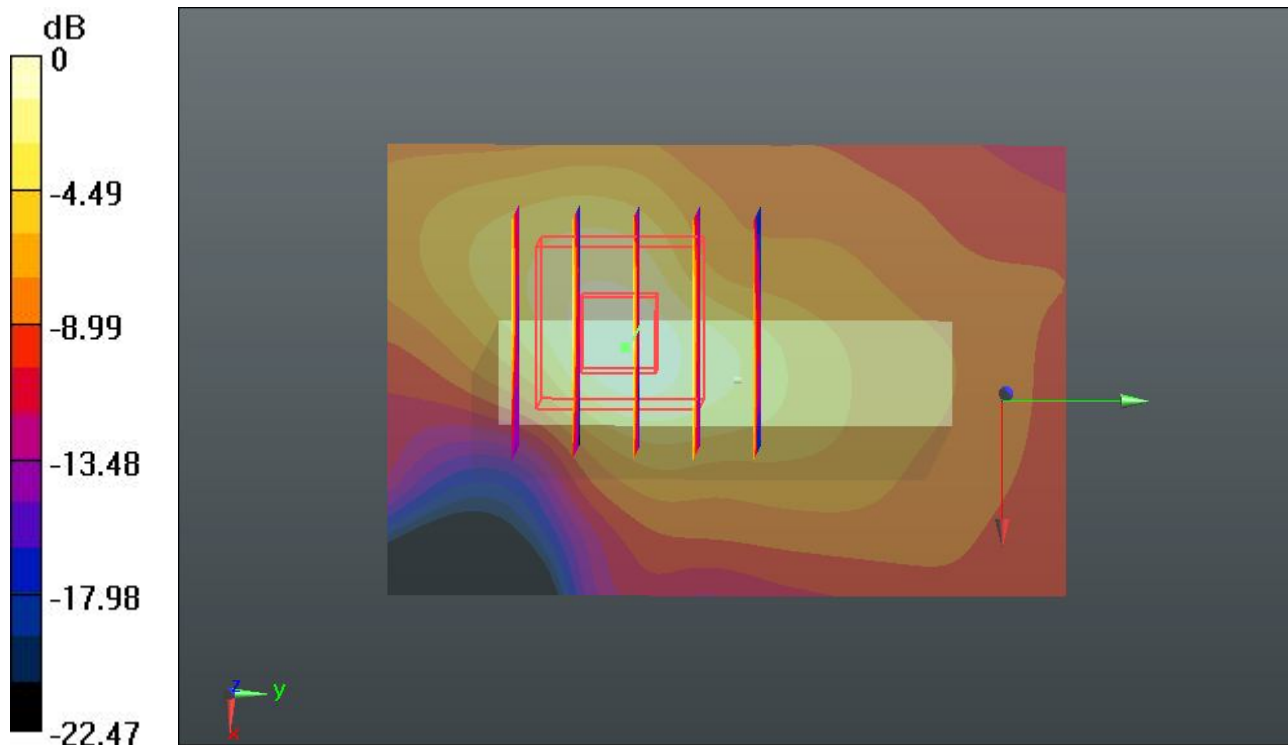

$0 \text{ dB} = 0.0268 \text{ mW/g} = -31.44 \text{ dB mW/g}$

63 802.11b_Back_1cm_Ch1_Headset

DUT: 251703

Communication System: WIFI; Frequency: 2412 MHz; Duty Cycle: 1:1

Medium: MSL_2450_120807 Medium parameters used: $f = 2412 \text{ MHz}$; $\sigma = 1.883 \text{ mho/m}$; $\epsilon_r =$

53.971 ; $\rho = 1000 \text{ kg/m}^3$

Ambient Temperature : $23.5 \text{ }^\circ\text{C}$; Liquid Temperature : $21.6 \text{ }^\circ\text{C}$

DASY5 Configuration:

- Probe: ES3DV3 - SN3270; ConvF(4.28, 4.28, 4.28); Calibrated: 12.09.2011;
- Sensor-Surface: 4mm (Mechanical Surface Detection)
- Electronics: DAE4 Sn1303; Calibrated: 10.11.2011
- Phantom: SAM2; Type: QD000P40CD; Serial: TP:1671
- Measurement SW: DASY52, Version 52.8 (1); SEMCAD X Version 14.6.5 (6469)

Ch1/Area Scan (61x91x1): Measurement grid: $dx=15\text{mm}$, $dy=15\text{mm}$

Maximum value of SAR (interpolated) = 0.0442 mW/g

Ch1/Zoom Scan (5x5x7)/Cube 0: Measurement grid: $dx=8\text{mm}$, $dy=8\text{mm}$, $dz=5\text{mm}$

Reference Value = 3.178 V/m ; Power Drift = -0.03 dB

Peak SAR (extrapolated) = 0.080 mW/g

SAR(1 g) = 0.043 mW/g ; SAR(10 g) = 0.024 mW/g

Maximum value of SAR (measured) = 0.0454 mW/g

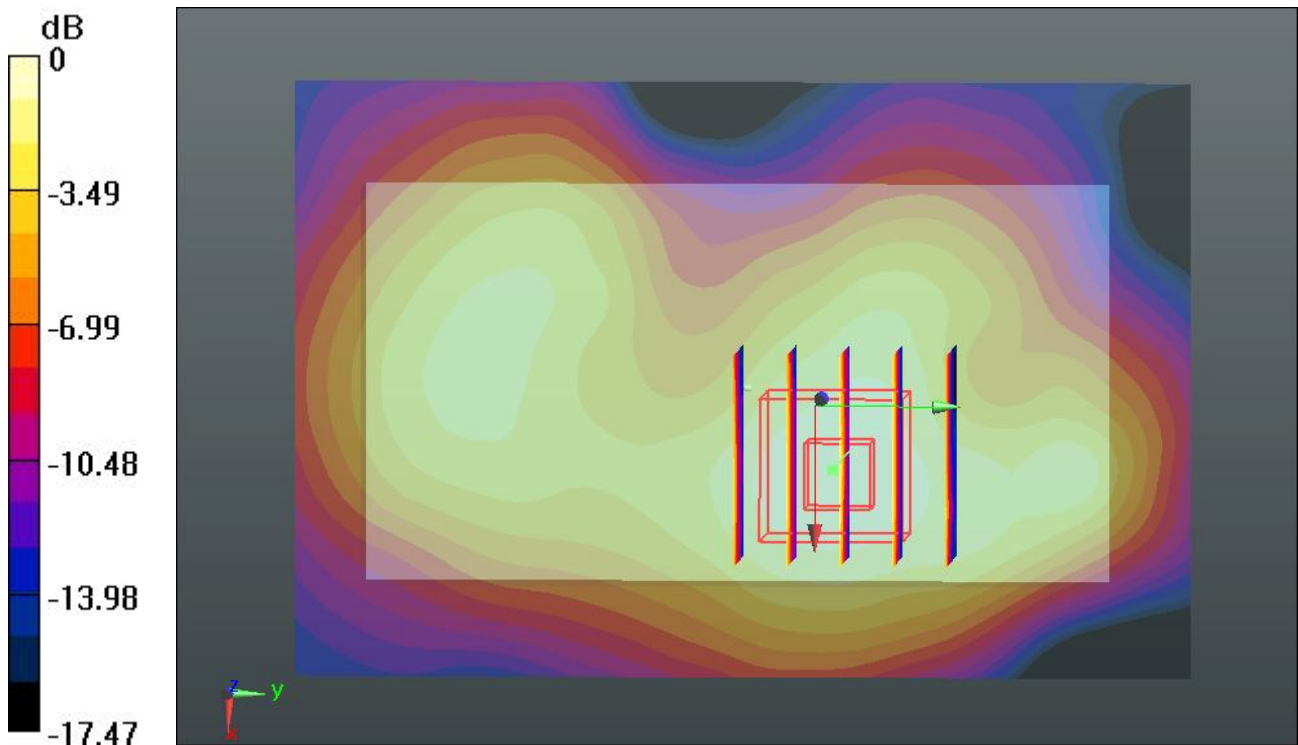

$0 \text{ dB} = 0.0454 \text{ mW/g} = -26.86 \text{ dB mW/g}$