



FCC RF Test Report

APPLICANT : Brightstar Corporation
EQUIPMENT : Smart Phone
BRAND NAME : Avvio
MODEL NAME : Avvio 774S, Avvio 774
FCC ID : WVBA774X
STANDARD : FCC 47 CFR Part 2, 22(H), 24(E)
CLASSIFICATION : PCS Licensed Transmitter Held to Ear (PCE)

The product was received on Jun. 26, 2015 and testing was completed on Jul. 28, 2015. We, SPORTON INTERNATIONAL (SHENZHEN) INC., would like to declare that the tested sample has been evaluated in accordance with the test procedures given in ANSI / TIA / EIA-603-C-2004 and has been in compliance with the applicable technical standards.

The test results in this report apply exclusively to the tested model / sample. Without written approval of SPORTON INTERNATIONAL (SHENZHEN) INC., the test report shall not be reproduced except in full.

Reviewed by: Joseph Lin / Supervisor

Approved by: Jones Tsai / Manager



SPORTON INTERNATIONAL (SHENZHEN) INC.

1F & 2F, Building A, Morning Business Center, No. 4003 ShiGu Rd., Xili Town,
Nanshan District, Shenzhen, Guangdong, P. R. China



TABLE OF CONTENTS

1 GENERAL DESCRIPTION 5

1.1 Applicant..... 5

1.2 Manufacturer 5

1.3 Product Feature of Equipment Under Test 5

1.4 Product Specification subjective to this standard..... 6

1.5 Modification of EUT 6

1.6 Maximum ERP/EIRP Power, Frequency Tolerance, and Emission Designator 7

1.7 Testing Location 8

1.8 Applicable Standards 8

2 TEST CONFIGURATION OF EQUIPMENT UNDER TEST 9

2.1 Test Mode..... 9

2.2 Connection Diagram of Test System 12

2.3 Support Unit used in test configuration 12

2.4 Measurement Results Explanation Example 13

3 TEST RESULT 14

3.1 Conducted Output Power Measurement..... 14

3.2 Peak-to-Average Ratio 16

3.3 Effective Radiated Power and Effective Isotropic Radiated Power Measurement 22

3.4 99% Occupied Bandwidth and 26dB Bandwidth Measurement..... 26

3.5 Band Edge Measurement..... 40

3.6 Conducted Spurious Emission Measurement..... 45

3.7 Field Strength of Spurious Radiation Measurement 50

3.8 Frequency Stability Measurement..... 56

4 LIST OF MEASURING EQUIPMENT 61

5 UNCERTAINTY OF EVALUATION 62

APPENDIX A. SETUP PHOTOGRAPHS



REVISION HISTORY

REPORT NO.	VERSION	DESCRIPTION	ISSUED DATE
FG562602	Rev. 01	Initial issue of report	Aug. 04, 2015



SUMMARY OF TEST RESULT

Report Section	FCC Rule	Description	Limit	Result	Remark
3.1	§2.1046	Conducted Output Power	N/A	PASS	-
3.2	§24.232(d)	Peak-to-Average Ratio	<13 dB	PASS	-
3.3	§22.913(a)(2)	Effective Radiated Power	< 7 Watts	PASS	-
	§24.232(c)	Equivalent Isotropic Radiated Power	< 2 Watts	PASS	-
3.4	§2.1049	Occupied Bandwidth	N/A	PASS	-
3.5	§2.1051 §22.917(a) §24.238(a)	Band Edge Measurement	< 43+10log ₁₀ (P[Watts])	PASS	-
3.6	§2.1051 §22.917(a) §24.238(a)	Conducted Spurious Emission	< 43+10log ₁₀ (P[Watts])	PASS	-
3.7	§2.1053 §22.917(a) §24.238(a)	Field Strength of Spurious Radiation	< 43+10log ₁₀ (P[Watts])	PASS	Under limit 28.86 dB at 3346.000 MHz
3.8	§2.1055 §22.355	Frequency Stability for Temperature & Voltage	< 2.5 ppm for Part 22 Within Authorized Band	PASS	-
	§2.1055 §24.235				



1 General Description

1.1 Applicant

Brightstar Corporation

9725 NW 117th Ave., Miami, Florida, FL 33178, United States

1.2 Manufacturer

Lakia Networks Co., Ltd.

2F, Unit A, Technology Service Building, Software Garden 1, Xiamen, Fujian, China

1.3 Product Feature of Equipment Under Test

Product Feature	
Equipment	Smart Phone
Brand Name	Avvio
Model Name	Avvio 774S, Avvio 774
FCC ID	WVBA774X
EUT supports Radios application	GSM/GPRS/EGPRS(Downlink Only)/ WCDMA/HSPA/HSPA+(Downlink Only)/ WLAN 2.4GHz 802.11b/g/n HT20/HT40 Bluetooth v3.0 + EDR/Bluetooth v4.0 LE
IMEI Code	Conducted: 356597028994924/356597028994932 Radiation: 356597028994965/356597028994973 ERP/EIRP: 356597028994965/356597028994973
HW Version	V1.1
SW Version	Avvio774S.W25.V0.0.6 Avvio774.W25.V0.0.3
EUT Stage	Identical Prototype

Remark:

1. The above EUT's information was declared by manufacturer. Please refer to the specifications or user's manual for more detailed description.
2. The difference of the two samples (Model Name: Avvio 774S, Avvio 774): Avvio 774 is single SIM card, Avvio 774S is dual SIM card. We only choose dual SIM sample to perform full tests.

1.4 Product Specification subjective to this standard

Product Specification subjective to this standard	
Tx Frequency	GSM850: 824.2 MHz ~ 848.8 MHz GSM1900: 1850.2 MHz ~ 1909.8MHz WCDMA Band V: 826.4 MHz ~ 846.6 MHz WCDMA Band II: 1852.4 MHz ~ 1907.6 MHz
Rx Frequency	GSM850: 869.2 MHz ~ 893.8 MHz GSM1900: 1930.2 MHz ~ 1989.8 MHz WCDMA Band V: 871.4 MHz ~ 891.6 MHz WCDMA Band II: 1932.4 MHz ~ 1987.6 MHz
Maximum Output Power to Antenna	GSM850 : 32.09 dBm GSM1900 : 28.64 dBm WCDMA Band V : 21.75 dBm WCDMA Band II : 21.16 dBm
Antenna Type	PCB Antenna
Type of Modulation	GSM: GMSK GPRS: GMSK EDGE: GMSK / 8PSK(Downlink Only) WCDMA: QPSK (Uplink) HSDPA: QPSK (Uplink) HSUPA: QPSK (Uplink) HSPA+: 16QAM (Downlink Only)

1.5 Modification of EUT

No modifications are made to the EUT during all test items.



1.6 Maximum ERP/EIRP Power, Frequency Tolerance, and Emission Designator

FCC Rule	System	Type of Modulation	Maximum ERP/EIRP (W)	Frequency Tolerance (ppm)	Emission Designator
Part 22	GSM850 GSM	GMSK	0.1837	0.0191 ppm	248KGXW
Part 22	WCDMA Band V RMC 12.2Kbps	QPSK	0.0235	0.0072 ppm	4M16F9W
Part 24	GSM1900 GSM	GMSK	0.3899	0.0064 ppm	246KGXW
Part 24	WCDMA Band II RMC 12.2Kbps	QPSK	0.0678	0.0021 ppm	4M17F9W

1.7 Testing Location

Test Site	SPORTON INTERNATIONAL (SHENZHEN) INC.	
Test Site Location	1F & 2F, Building A, Morning Business Center, No. 4003 ShiGu Rd., Xili Town, Nanshan District, Shenzhen, Guangdong, P. R. China TEL: +86-755-8637-9589 FAX: +86-755-8637-9595	
Test Site No.	Sporton Site No.	
	TH01-SZ	

Test Site	SPORTON INTERNATIONAL (SHENZHEN) INC.	
Test Site Location	No. 3 Building, the third floor of south, Shahe River west, Fengzeyuan warehouse, Nanshan District, Shenzhen, Guangdong, P. R. China TEL: +86-755- 3320-2398	
Test Site No.	Sporton Site No.	FCC Registration No.
	03CH01-SZ	831040

1.8 Applicable Standards

According to the specifications of the manufacturer, the EUT must comply with the requirements of the following standards:

- ♦ FCC 47 CFR Part 2, 22(H), 24(E)
- ♦ ANSI / TIA / EIA-603-C-2004
- ♦ FCC KDB 971168 D01 Power Meas. License Digital Systems v02r02

Remark:

1. All test items were verified and recorded according to the standards and without any deviation during the test.
2. This EUT has also been tested and complied with the requirements of FCC Part 15, Subpart B, recorded in a separate test report.



2 Test Configuration of Equipment Under Test

2.1 Test Mode

Antenna port conducted and radiated test items were performed according to KDB 971168 D01 Power Meas. License Digital Systems v02r02 with maximum output power.

Radiated measurements were performed with rotating EUT in different three orthogonal test planes to find the maximum emission.

Radiated emissions were investigated as following frequency range:

1. 30 MHz to 10th harmonic for GSM850 and WCDMA Band V.
2. 30 MHz to 10th harmonic for GSM1900 and WCDMA Band II.

All modes and data rates and positions were investigated.

Test modes are chosen to be reported as the worst case configuration below:

Test Modes		
Band	Radiated TCs	Conducted TCs
GSM 850	■ GSM Link	■ GSM Link
GSM 1900	■ GSM Link	■ GSM Link
WCDMA Band V	■ RMC 12.2Kbps Link	■ RMC 12.2Kbps Link
WCDMA Band II	■ RMC 12.2Kbps Link	■ RMC 12.2Kbps Link



Conducted Power Measurement Results:

SIM1 Card:

Conducted Power (*Unit: dBm)						
Band	GSM850			GSM1900		
Channel	128	189	251	512	661	810
Frequency	824.2	836.4	848.8	1850.2	1880.0	1909.8
GSM	31.92	32.09	31.92	28.64	28.57	28.54
GPRS class 8	31.91	32.07	31.89	28.63	28.53	28.52
GPRS class 10	31.22	31.38	31.17	28.52	28.51	28.38
GPRS class 11	29.86	30.03	29.82	27.77	27.73	27.68
GPRS class 12	29.18	29.36	29.17	27.07	27.00	26.98

Conducted Power (*Unit: dBm)						
Band	WCDMA Band V			WCDMA Band II		
Channel	4132	4182	4233	9262	9400	9538
Frequency	826.4	836.4	846.6	1852.4	1880.0	1907.6
AMR 12.2K	21.74	21.30	21.62	21.14	20.76	20.58
RMC 12.2K	21.75	21.32	21.63	21.16	20.78	20.59
HSDPA Subtest-1	20.53	20.15	20.38	19.75	19.40	19.06
HSDPA Subtest-2	20.53	20.14	20.38	19.75	19.38	19.07
HSDPA Subtest-3	20.10	19.74	19.98	19.29	18.94	18.61
HSDPA Subtest-4	20.09	19.69	19.94	19.28	18.91	18.57
HSUPA Subtest-1	18.58	18.17	18.44	17.84	17.46	17.16
HSUPA Subtest-2	18.60	18.19	18.45	17.84	17.45	17.16
HSUPA Subtest-3	19.56	19.17	19.43	18.80	18.46	18.11
HSUPA Subtest-4	18.05	17.65	17.86	17.27	16.90	16.63
HSUPA Subtest-5	20.53	20.22	20.40	19.82	19.43	19.12



SIM2 Card:

Conducted Power (*Unit: dBm)						
Band	GSM850			GSM1900		
Channel	128	189	251	512	661	810
Frequency	824.2	836.4	848.8	1850.2	1880.0	1909.8
GSM	31.72	31.86	31.77	28.46	28.32	28.27
GPRS class 8	31.70	31.85	31.75	28.45	28.30	28.26
GPRS class 10	31.00	31.20	31.07	28.35	28.22	28.14
GPRS class 11	29.66	29.83	29.72	27.59	27.50	27.47
GPRS class 12	28.95	29.16	29.04	26.82	26.78	26.77

Conducted Power (*Unit: dBm)						
Band	WCDMA Band V			WCDMA Band II		
Channel	4132	4182	4233	9262	9400	9538
Frequency	826.4	836.4	846.6	1852.4	1880.0	1907.6
AMR 12.2K	21.71	21.12	21.61	21.11	20.74	20.51
RMC 12.2K	21.73	21.14	21.62	21.12	20.76	20.53
HSDPA Subtest-1	20.49	20.14	20.35	19.71	19.36	19.02
HSDPA Subtest-2	20.52	20.13	20.36	19.73	19.34	19.05
HSDPA Subtest-3	20.08	19.67	19.94	19.24	18.92	18.59
HSDPA Subtest-4	20.05	19.68	19.90	19.24	18.87	18.55
HSUPA Subtest-1	18.54	18.15	18.43	17.82	17.45	17.14
HSUPA Subtest-2	18.56	18.18	18.42	17.82	17.42	17.10
HSUPA Subtest-3	19.60	19.16	19.41	18.78	18.43	18.09
HSUPA Subtest-4	18.03	17.62	17.84	17.25	16.90	16.61
HSUPA Subtest-5	20.50	20.20	20.30	19.80	19.40	19.10

2.2 Connection Diagram of Test System

For 22H:

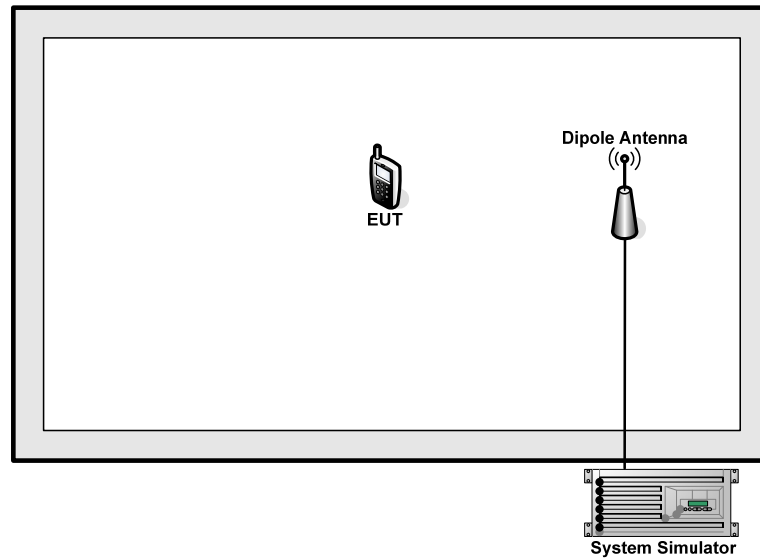

For 24E:

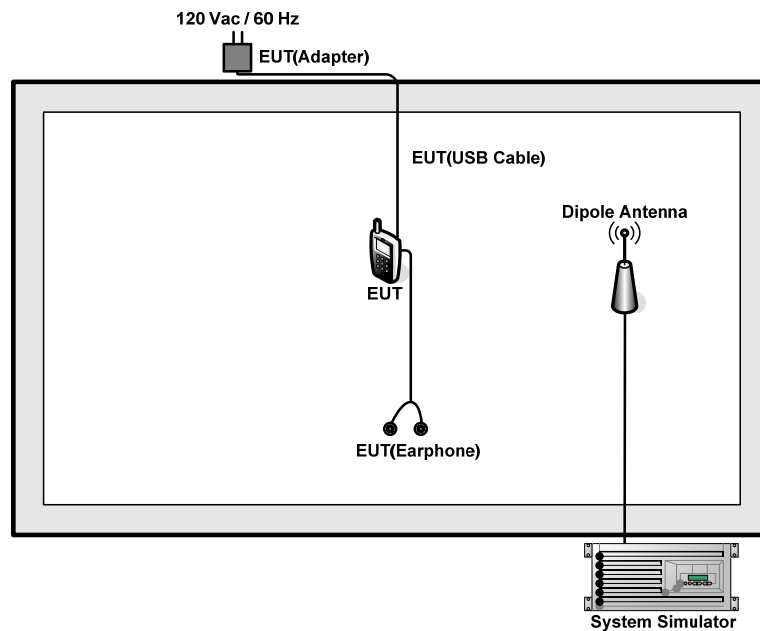

2.3 Support Unit used in test configuration

Item	Equipment	Trade Name	Model No.	FCC ID	Data Cable	Power Cord
1.	System Simulator	R&S	CMU 200	N/A	N/A	Unshielded, 1.8 m
2.	DC Power Supply	GW INSTRON	GPS-3030D	N/A	N/A	Unshielded, 1.8 m



2.4 Measurement Results Explanation Example

For all conducted test items:

The offset level is set in the spectrum analyzer to compensate the RF cable loss and attenuator factor between RF conducted output port and spectrum analyzer. With the offset compensation, the spectrum analyzer reading level will be exactly the RF output level.

The spectrum analyzer offset is derived from RF cable loss and attenuator factor.

Offset = RF cable loss + attenuator factor.

The following shows an offset computation example with RF cable loss 4.5 dB and a 10dB attenuator.

Example :

$$\begin{aligned} \text{Offset(dB)} &= \text{RF cable loss(dB)} + \text{attenuator factor(dB)}. \\ &= 4.5 + 10 = 14.5 \text{ (dB)} \end{aligned}$$

3 Test Result

3.1 Conducted Output Power Measurement

3.1.1 Description of the Conducted Output Power Measurement

A system simulator was used to establish communication with the EUT. Its parameters were set to enforce EUT transmitting at the maximum power. The measured power in the radio frequency on the transmitter output terminals shall be reported.

3.1.2 Measuring Instruments

The measuring equipment is listed in the section 4 of this test report.

3.1.3 Test Procedures

1. The transmitter output port was connected to the system simulator.
2. Set EUT at maximum power through system simulator.
3. Select lowest, middle, and highest channels for each band and different modulation.
4. Measure the maximum burst average power for GSM and maximum average power for other modulation signal.

3.1.4 Test Setup

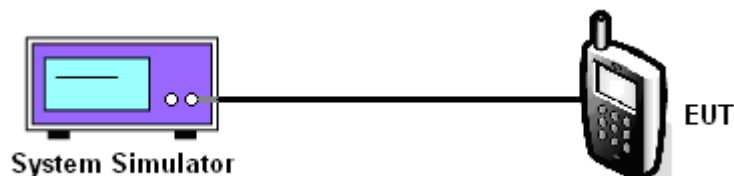

3.1.5 Test Result of Conducted Output Power

Cellular Band						
Modes	GSM850 (GSM)			WCDMA Band V (RMC 12.2Kbps)		
Channel	128 (Low)	189 (Mid)	251 (High)	4132 (Low)	4182 (Mid)	4233 (High)
Frequency (MHz)	824.2	836.4	848.8	826.4	836.4	846.6
Conducted Power (dBm)	31.92	32.09	31.92	21.75	21.32	21.63

PCS Band						
Modes	GSM1900 (GSM)			WCDMA Band II (RMC 12.2Kbps)		
Channel	512 (Low)	661 (Mid)	810 (High)	9262 (Low)	9400 (Mid)	9538 (High)
Frequency (MHz)	1850.2	1880	1909.8	1852.4	1880	1907.6
Conducted Power (dBm)	28.64	28.57	28.54	21.16	20.78	20.59

Note: maximum burst average power for GSM, and maximum average power for WCDMA.

3.2 Peak-to-Average Ratio

3.2.1 Description of the PAR Measurement

The peak-to-average ratio (PAR) of the transmission may not exceed 13 dB.

3.2.2 Measuring Instruments

The measuring equipment is listed in the section 4 of this test report.

3.2.3 Test Procedures

1. The testing follows FCC KDB 971168 v02r02 Section 5.7.1.
2. The EUT was connected to the spectrum analyzer and system simulator via a power divider.
3. For GSM/EGPRS operating modes:
 - a. Set EUT in maximum power output.
 - b. Set the RBW = 1MHz, VBW = 3MHz, Peak detector on spectrum analyzer for first trace.
 - c. Set the RBW = 1MHz, VBW = 3MHz, RMS detector on spectrum analyzer for second trace.
 - d. The wanted burst signal is triggered by spectrum analyzer, and measured respectively the peak level and Mean level without burst-off time, after system simulator has synchronized with the spectrum analyzer.
4. For UMTS operating modes:
 - a. Set the CCDF (Complementary Cumulative Distribution Function) option on the spectrum analyzer.
 - b. The highest RF powers were measured and recorded the maximum PAPR level associated with a probability of 0.1 %.
5. Record the deviation as Peak to Average Ratio.

3.2.4 Test Setup

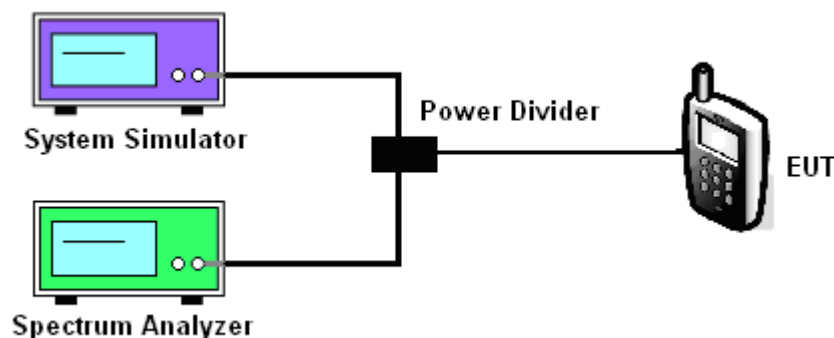



3.2.5 Test Result of Peak-to-Average Ratio

PCS Band						
Modes	GSM1900 (GSM)			WCDMA Band II (RMC 12.2Kbps)		
Channel	512 (Low)	661 (Mid)	810 (High)	9262 (Low)	9400 (Mid)	9538 (High)
Frequency (MHz)	1850.2	1880	1909.8	1852.4	1880	1907.6
Peak-to-Average Ratio (dB)	0.28	0.28	0.27	3.04	3.12	3.08



3.2.6 Test Result (Plots) of Peak-to-Average Ratio

Band :	GSM 1900	Test Mode :	GSM Link (GMSK)
--------	----------	-------------	-----------------

Peak-to-Average Ratio on Channel 512 (1850.2 MHz)

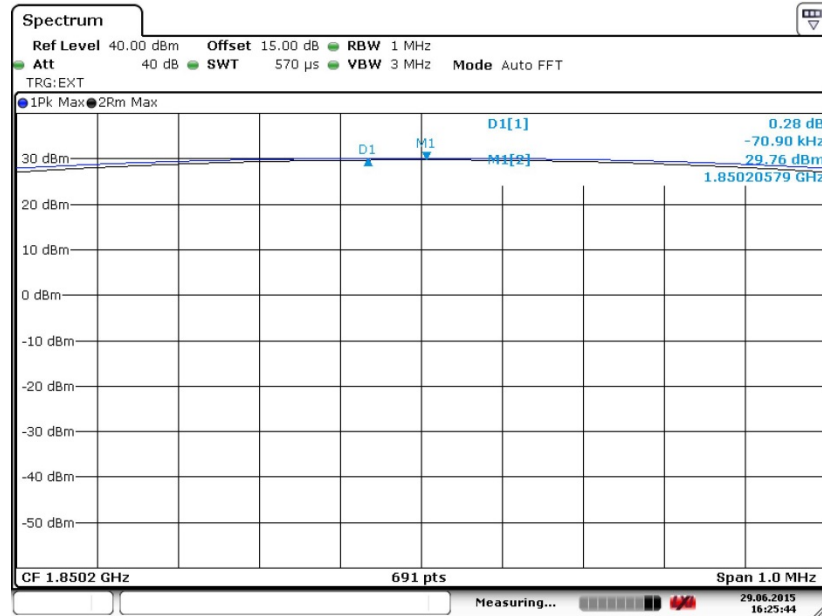

Date: 29.JUN.2015 16:25:44

Peak-to-Average Ratio on Channel 661 (1880.0 MHz)

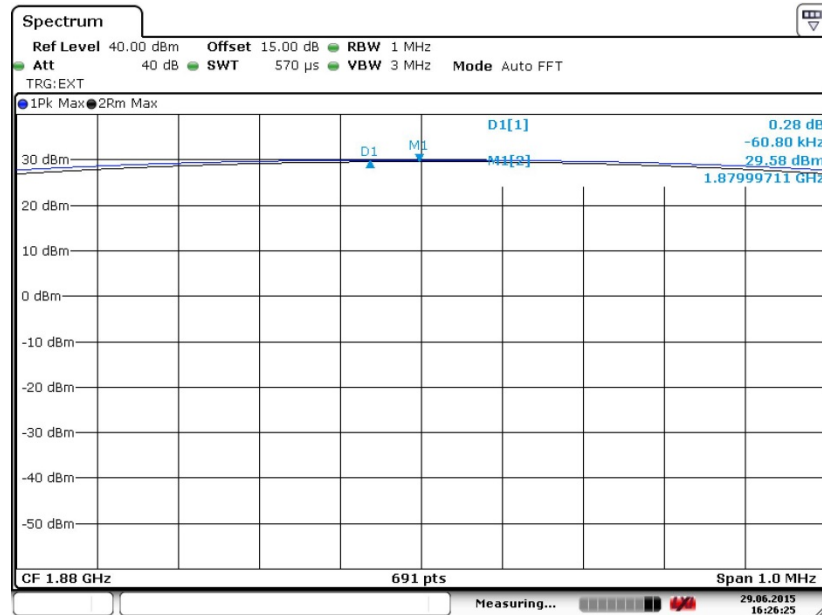

Date: 29.JUN.2015 16:26:25



Peak-to-Average Ratio on Channel 810 (1909.8 MHz)

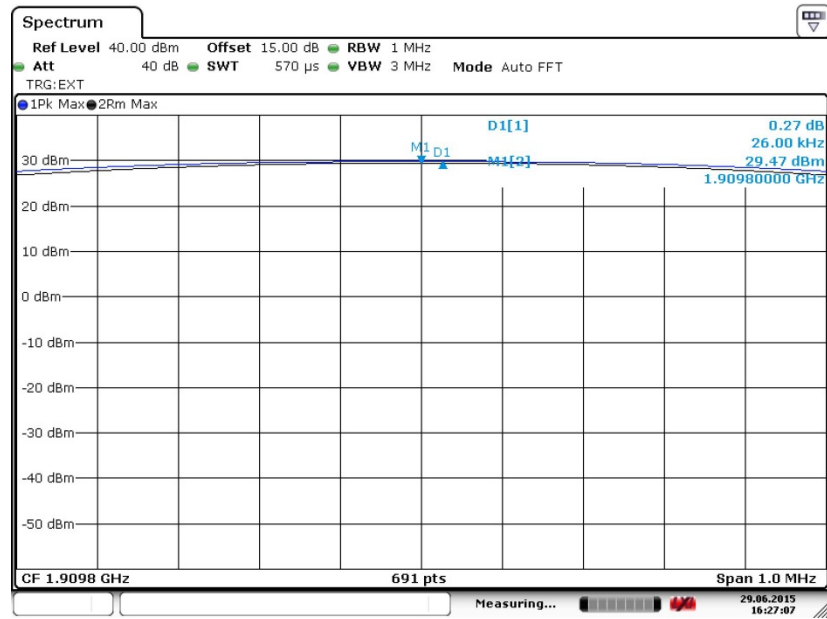

Date: 29.JUN.2015 16:27:07



Band :	WCDMA Band II	Test Mode :	RMC 12.2Kbps Link (QPSK)
---------------	---------------	--------------------	--------------------------

Peak-to-Average Ratio on Channel 9262 (1852.4 MHz)

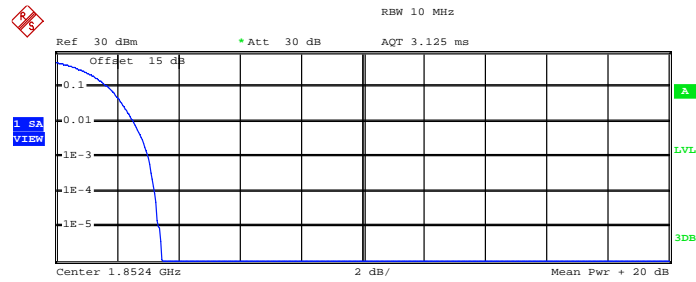

Complementary Cumulative Distribution Function (100000 samples)

Trace 1
 Mean 22.28 dBm
 Peak 25.74 dBm
 Crest 3.46 dB

10 % 1.72 dB
 1 % 2.56 dB
 .1 % 3.04 dB
 .01 % 3.24 dB

Date: 30.JUN.2015 23:51:52

Peak-to-Average Ratio on Channel 9400 (1880.0 MHz)

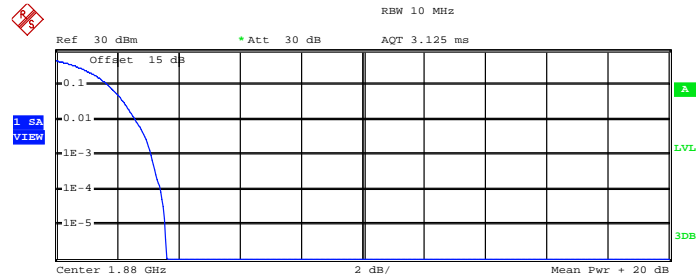

Complementary Cumulative Distribution Function (100000 samples)

Trace 1
 Mean 21.99 dBm
 Peak 25.60 dBm
 Crest 3.61 dB

10 % 1.72 dB
 1 % 2.60 dB
 .1 % 3.12 dB
 .01 % 3.44 dB

Date: 30.JUN.2015 23:52:14



Peak-to-Average Ratio on Channel 9538 (1907.6 MHz)

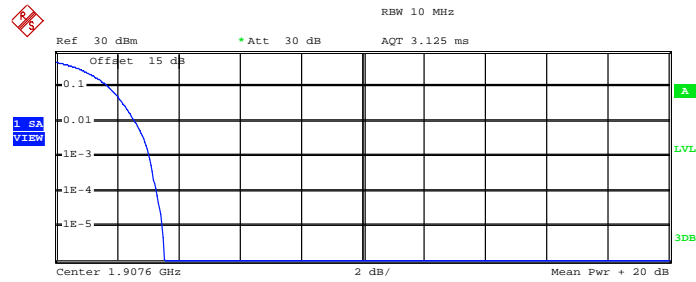

Complementary Cumulative Distribution Function (100000 samples)

Trace 1

Mean	21.56 dBm
Peak	25.10 dBm
Crest	3.55 dB
10 %	1.72 dB
1 %	2.60 dB
.1 %	3.08 dB
.01 %	3.28 dB

Date: 30.JUN.2015 23:52:45



3.3 Effective Radiated Power and Effective Isotropic Radiated Power Measurement

3.3.1 Description of the ERP/EIRP Measurement

The substitution method, in ANSI / TIA / EIA-603-C-2004, was used for ERP/EIRP measurement, and the spectrum analyzer configuration follows KDB 971168 D01 Power Meas. License Digital Systems v02r02. The ERP of mobile transmitters must not exceed 7 Watts and the EIRP of mobile transmitters are limited to 2 Watts.

3.3.2 Measuring Instruments

The measuring equipment is listed in the section 4 of this test report.

3.3.3 Test Procedures

1. The testing follows FCC KDB 971168 v02r02 Section 5.2.1. (for CDMA/WCDMA), Section 5.2.2.2 (for GSM/GPRS/EDGE) and ANSI / TIA-603-C-2004 Section 2.2.17.
2. The EUT was placed on a non-conductive rotating platform 0.8 meters high in a semi-anechoic chamber. The radiated emission at the fundamental frequency was measured at 3 m with a test antenna and a spectrum analyzer with RMS detector per section 5. of KDB 971168 D01.
3. During the measurement, the system simulator parameters were set to force the EUT transmitting at maximum output power. The maximum emission was recorded from analyzer power level (LVL) from the 360 degrees rotation of the turntable and the test antenna raised and lowered over a range from 1 to 4 meters in both horizontally and vertically polarized orientations.
4. Effective Isotropic Radiated Power (EIRP) was measured by substitution method according to TIA/EIA-603-C. The EUT was replaced by the substitution antenna at same location, and then a known power from S.G. was applied into the dipole antenna through a Tx cable, and then recorded the maximum Analyzer reading through raised and lowered the test antenna. The correction factor (in dB) = S.G. - Tx Cable loss + Substitution antenna gain - Analyzer reading. Then the EUT's EIRP was calculated with the correction factor, $EIRP = LVL + \text{Correction factor}$ and $ERP = EIRP - 2.15$. Take the record of the output power at substitution antenna.



	GSM/GPRS/EDGE	WCDMA/HSPA
SPAN	500kHz	10MHz
RBW	10kHz	100kHz
VBW	30kHz	300kHz
Detector	RMS	RMS
Trace	Average	Average
Average Type	Power	Power
Sweep Count	100	100

3.3.4 Test Result of ERP

GSM850 (GSM) Radiated Power ERP					
Channel	Frequency (MHz)	Horizontal		Vertical	
		ERP(dBm)	ERP(W)	ERP(dBm)	ERP(W)
Lowest	824.20	22.49	0.1774	12.84	0.0192
Middle	836.40	22.64	0.1837	13.20	0.0209
Highest	848.80	22.40	0.1738	13.76	0.0238
Limit	ERP < 7W	Result		PASS	

WCDMA Band V (RMC 12.2Kbps) Radiated Power ERP					
Channel	Frequency (MHz)	Horizontal		Vertical	
		ERP(dBm)	ERP(W)	ERP(dBm)	ERP(W)
Lowest	826.40	13.71	0.0235	4.20	0.0026
Middle	836.40	12.01	0.0159	2.82	0.0019
Highest	846.60	13.25	0.0211	4.55	0.0029
Limit	ERP < 7W	Result		PASS	



3.3.5 Test Result of EIRP

GSM1900 (GSM) Radiated Power EIRP					
Channel	Frequency (MHz)	Horizontal		Vertical	
		EIRP(dBm)	EIRP(W)	EIRP(dBm)	EIRP(W)
Lowest	1850.20	25.40	0.3467	25.91	0.3899
Middle	1880.00	24.94	0.3119	25.41	0.3475
Highest	1909.80	24.60	0.2884	24.72	0.2965
Limit	EIRP < 2W	Result		PASS	

WCDMA Band II (RMC 12.2Kbps) Radiated Power EIRP					
Channel	Frequency (MHz)	Horizontal		Vertical	
		EIRP(dBm)	EIRP(W)	EIRP(dBm)	EIRP(W)
Lowest	1852.40	17.12	0.0515	17.80	0.0603
Middle	1880.00	17.78	0.0600	18.31	0.0678
Highest	1907.60	17.82	0.0605	17.95	0.0624
Limit	EIRP < 2W	Result		PASS	

3.4 99% Occupied Bandwidth and 26dB Bandwidth Measurement

3.4.1 Description of 99% Occupied Bandwidth and 26dB Bandwidth Measurement

The 99% occupied bandwidth is the width of a frequency band such that, below the lower and above the upper frequency limits, the mean powers emitted are each equal to a specified percentage 0.5% of the total mean transmitted power.

The emission bandwidth is defined as the width of the signal between two points, located at the 2 sides of the carrier frequency, outside of which all emissions are attenuated at least 26 dB below the transmitter power.

3.4.2 Measuring Instruments

The measuring equipment is listed in the section 4 of this test report.

3.4.3 Test Procedures

1. The testing follows FCC KDB 971168 v02r02 Section 4.2.
2. The EUT was connected to the spectrum analyzer and system simulator via a power divider.
3. The RF output of the EUT was connected to the spectrum analyzer by RF cable and attenuator. The path loss was compensated to the results for each measurement.
4. The 99% occupied bandwidth were measured, set RBW= 1% of span, VBW= 3*RBW, peak detector, trace maximum hold.
5. The 26dB bandwidth were measured, set RBW= 1% of EBW, VBW= 3*RBW, peak detector, trace maximum hold.

3.4.4 Test Setup

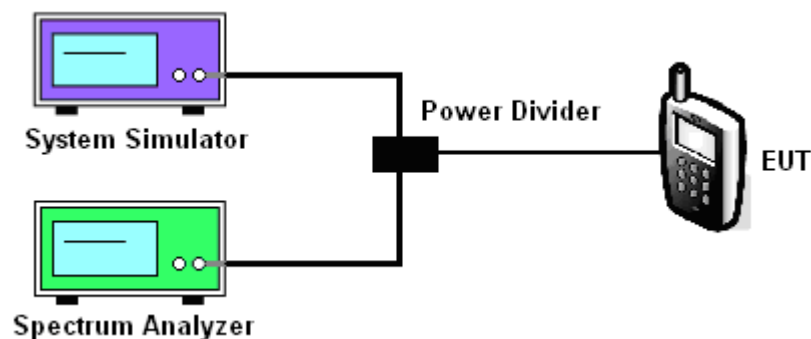



3.4.5 Test Result of Occupied Bandwidth and 26dB Bandwidth

Cellular Band			
Modes	GSM850 (GSM)		
Channel	128 (Low)	189 (Mid)	251 (High)
Frequency (MHz)	824.2	836.4	848.8
99% OBW (kHz)	246.00	245.00	248.00
26dB BW (kHz)	305.00	300.00	295.00

PCS Band			
Modes	GSM1900 (GSM)		
Channel	512 (Low)	661 (Mid)	810 (High)
Frequency (MHz)	1850.2	1880	1909.8
99% OBW (kHz)	245.00	246.00	246.00
26dB BW (kHz)	306.00	302.00	289.00

Cellular Band			
Modes	WCDMA Band V (RMC 12.2Kbps)		
Channel	4132 (Low)	4182 (Mid)	4233 (High)
Frequency (MHz)	826.4	836.4	846.6
99% OBW (MHz)	4.16	4.16	4.16
26dB BW (MHz)	4.67	4.67	4.68

PCS Band			
Modes	WCDMA Band II (RMC 12.2Kbps)		
Channel	9262 (Low)	9400 (Mid)	9538 (High)
Frequency (MHz)	1852.4	1880	1907.6
99% OBW (MHz)	4.16	4.17	4.17
26dB BW (MHz)	4.68	4.69	4.67



3.4.6 Test Result (Plots) of Occupied Bandwidth and 26dB Bandwidth

Band :	GSM 850	Test Mode :	GSM Link (GMSK)
--------	---------	-------------	-----------------

99% Occupied Bandwidth Plot on Channel 128 (824.2 MHz)

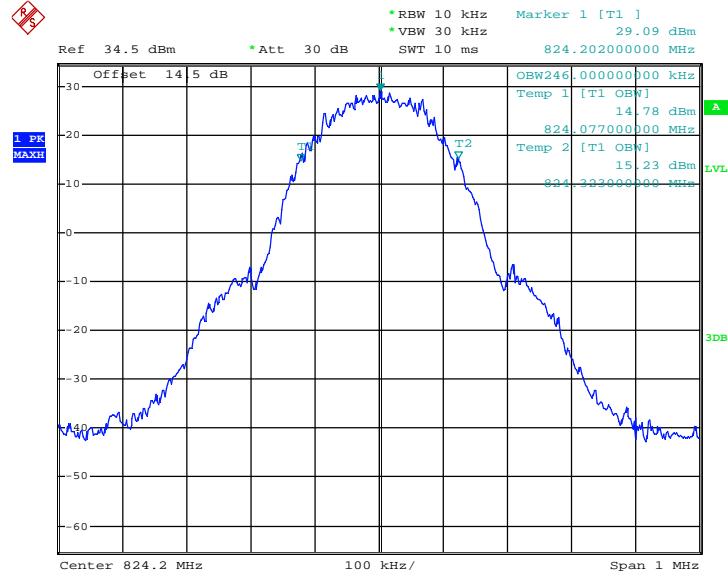

Date: 30.JUN.2015 22:37:04

26dB Bandwidth Plot on Channel 128 (824.2 MHz)

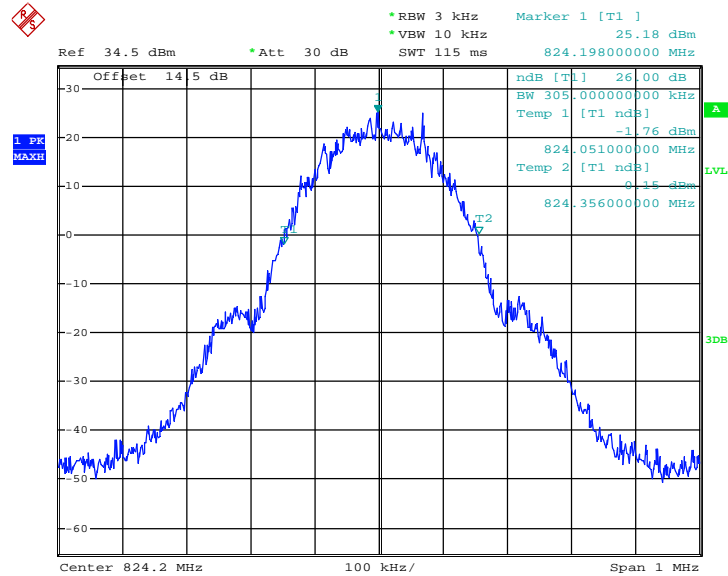

Date: 30.JUN.2015 22:35:00



99% Occupied Bandwidth Plot on Channel 189 (836.4 MHz)

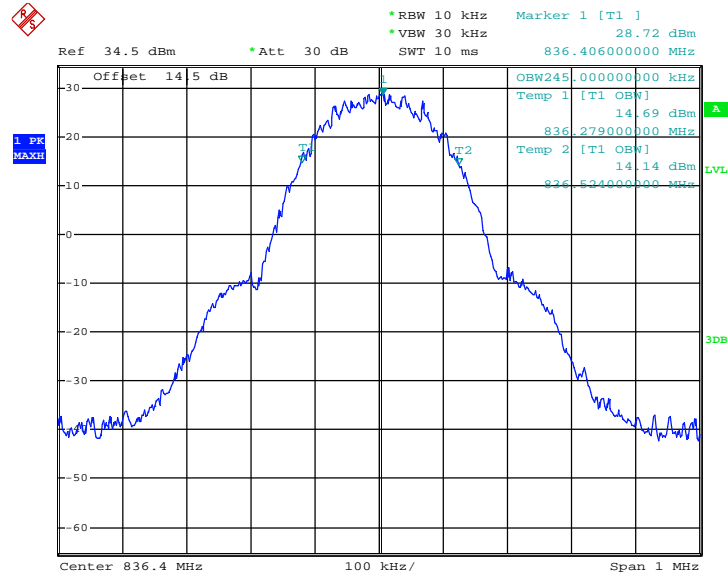

Date: 30.JUN.2015 22:37:39

26dB Bandwidth Plot on Channel 189 (836.4 MHz)

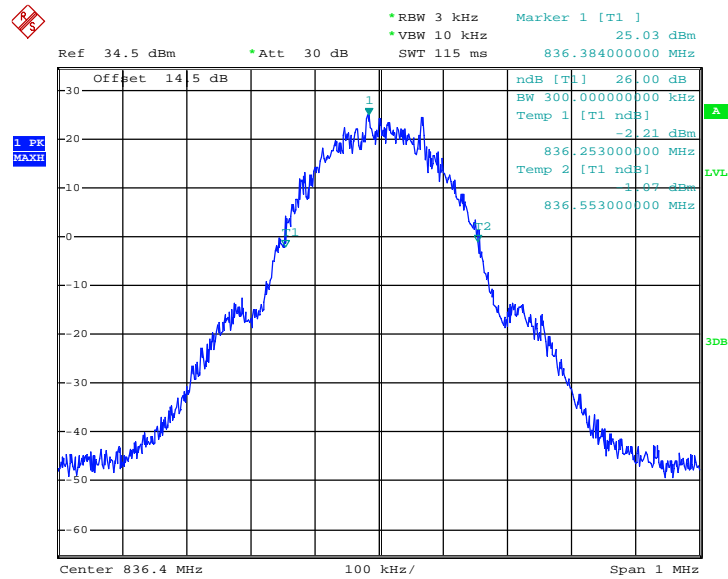

Date: 30.JUN.2015 22:35:43



99% Occupied Bandwidth Plot on Channel 251 (848.8 MHz)

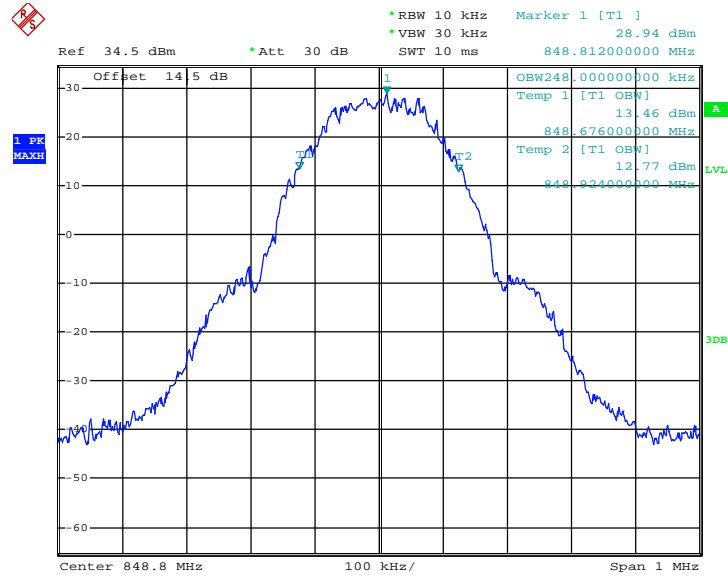

Date: 30.JUN.2015 22:38:13

26dB Bandwidth Plot on Channel 251 (848.8 MHz)

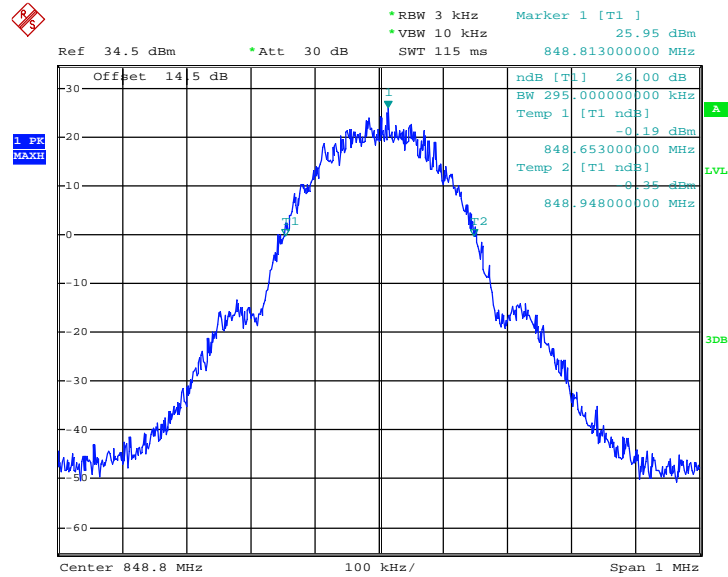

Date: 30.JUN.2015 22:36:16



Band :	GSM 1900	Test Mode :	GSM Link (GMSK)
--------	----------	-------------	-----------------

99% Occupied Bandwidth Plot on Channel 512 (1850.2 MHz)

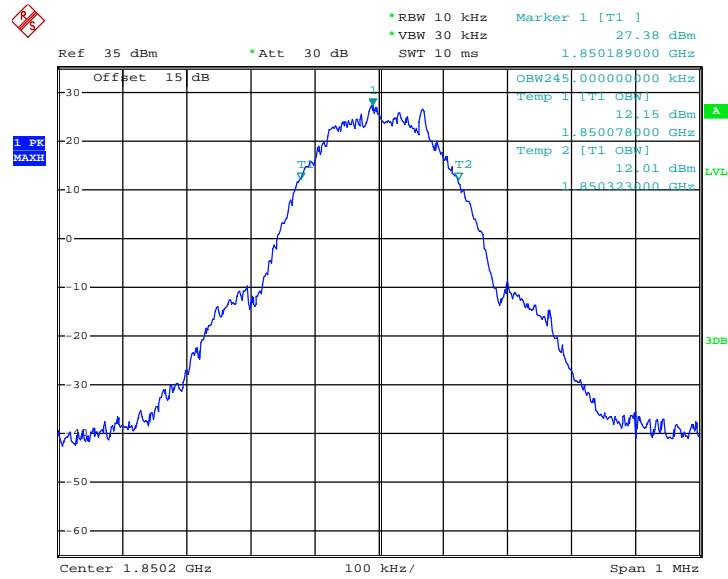

Date: 30.JUN.2015 23:04:24

26dB Bandwidth Plot on Channel 512 (1850.2 MHz)

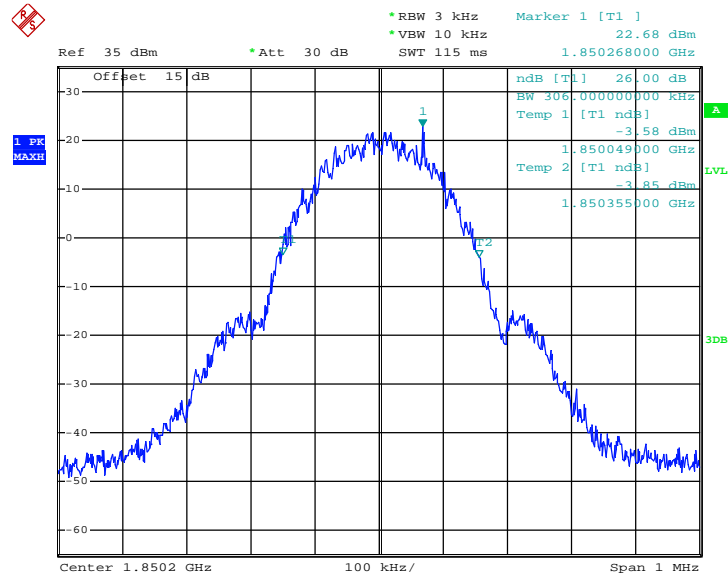

Date: 30.JUN.2015 23:01:37



99% Occupied Bandwidth Plot on Channel 661 (1880.0 MHz)

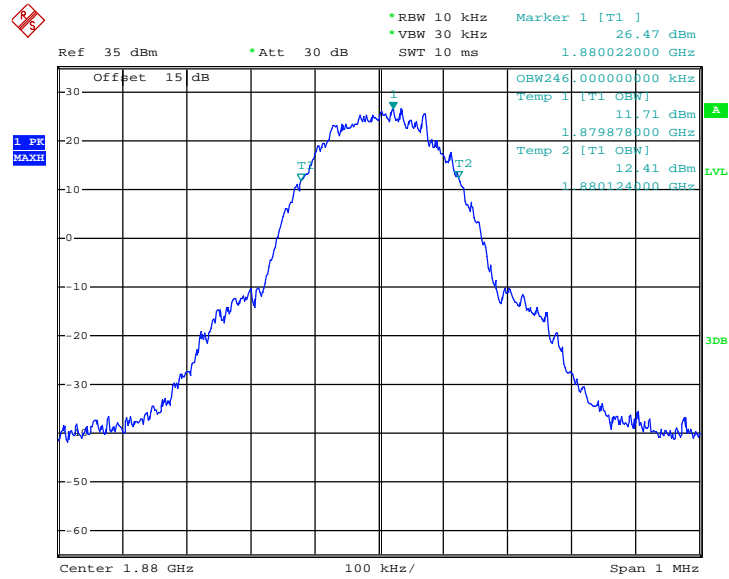

Date: 30.JUN.2015 23:05:42

26dB Bandwidth Plot on Channel 661 (1880.0 MHz)

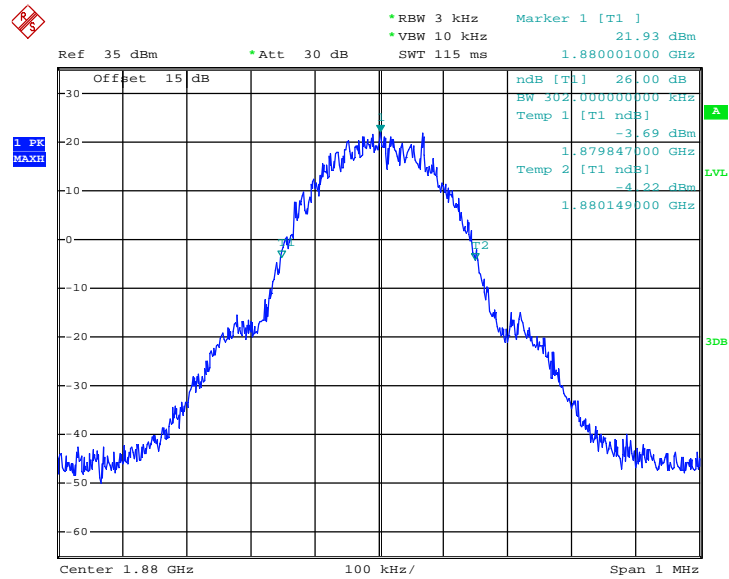

Date: 30.JUN.2015 23:02:17



99% Occupied Bandwidth Plot on Channel 810 (1909.8 MHz)

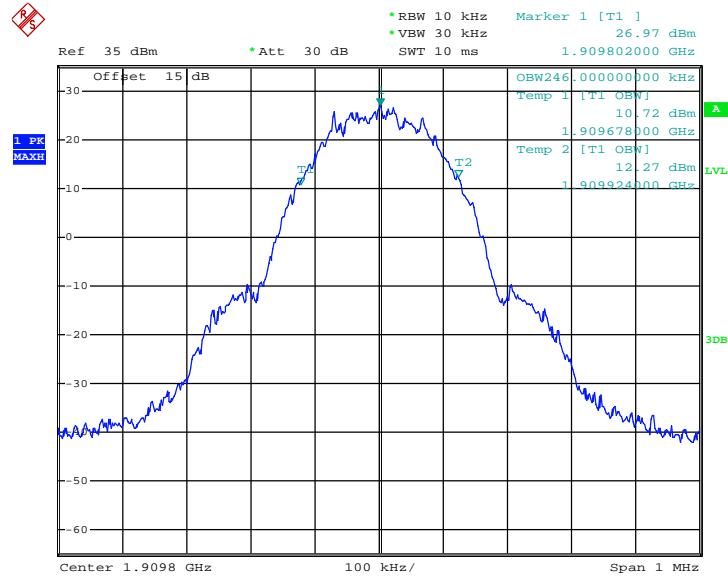

Date: 30.JUN.2015 23:06:19

26dB Bandwidth Plot on Channel 810 (1909.8 MHz)

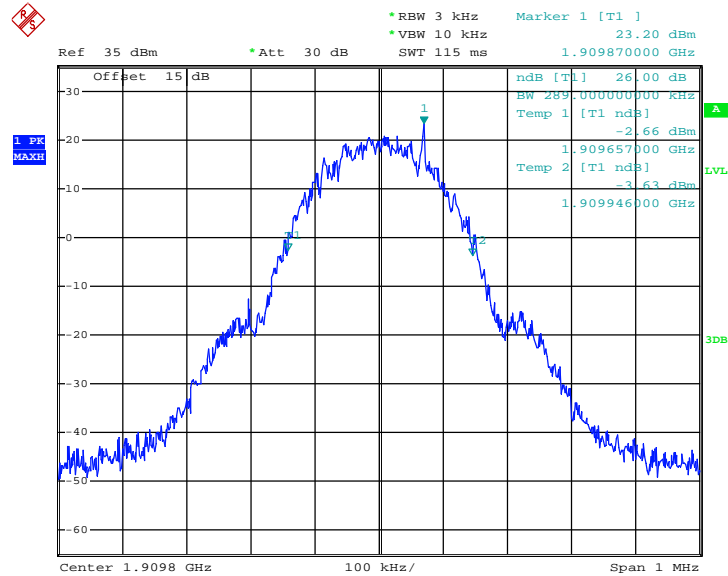

Date: 30.JUN.2015 23:08:53



Band :	WCDMA Band V	Test Mode :	RMC 12.2Kbps Link (QPSK)
--------	--------------	-------------	--------------------------

99% Occupied Bandwidth Plot on Channel 4132 (826.4 MHz)

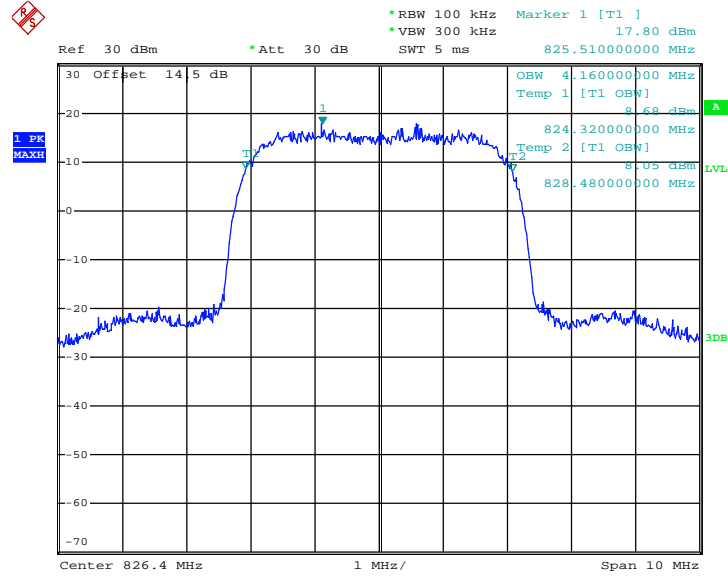

Date: 30.JUN.2015 23:57:57

26dB Bandwidth Plot on Channel 4132 (826.4 MHz)

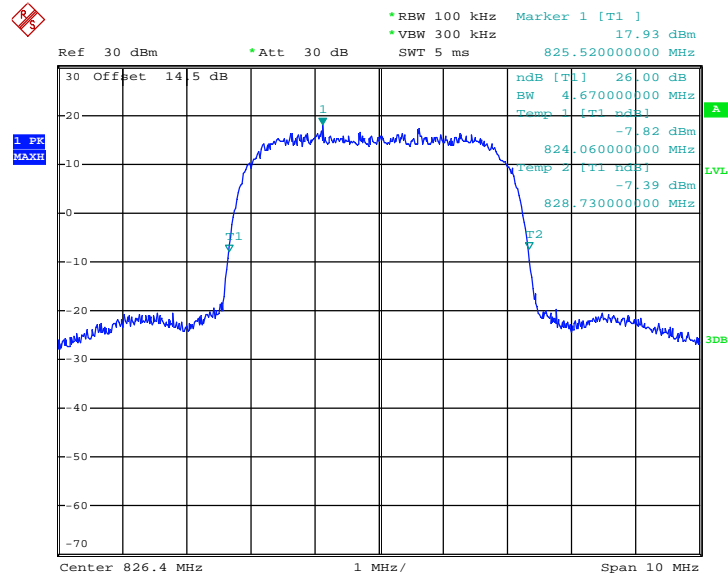

Date: 30.JUN.2015 23:55:33



99% Occupied Bandwidth Plot on Channel 4182 (836.4 MHz)

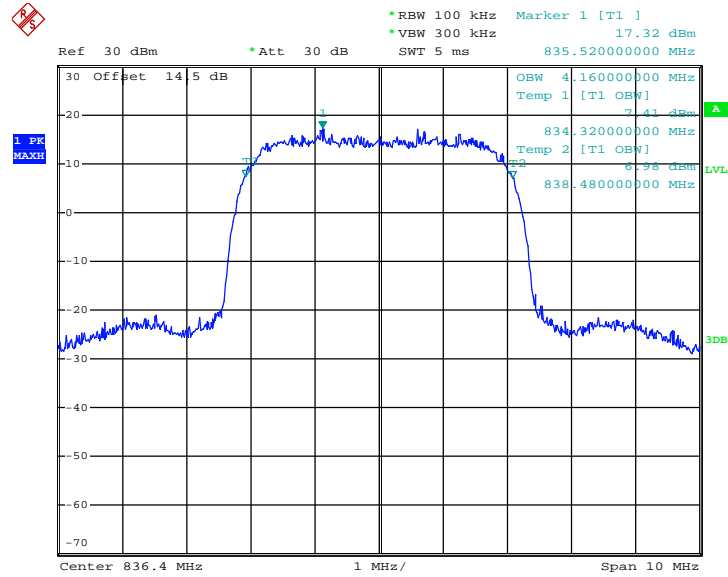

Date: 30.JUN.2015 23:58:29

26dB Bandwidth Plot on Channel 4182 (836.4 MHz)

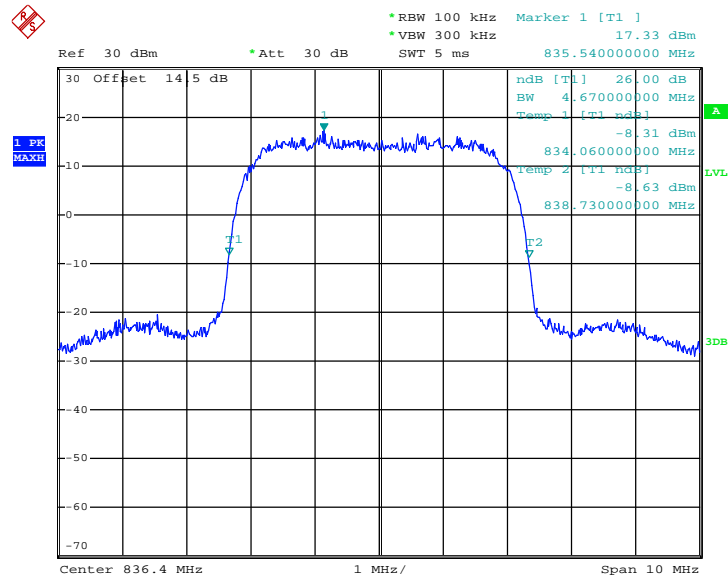

Date: 30.JUN.2015 23:56:13



99% Occupied Bandwidth Plot on Channel 4233 (846.6 MHz)

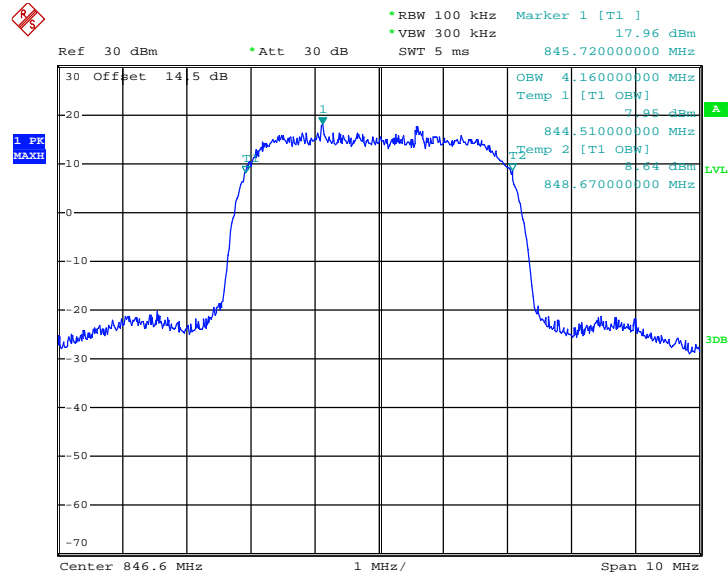

Date: 30.JUN.2015 23:59:13

26dB Bandwidth Plot on Channel 4233 (846.6 MHz)

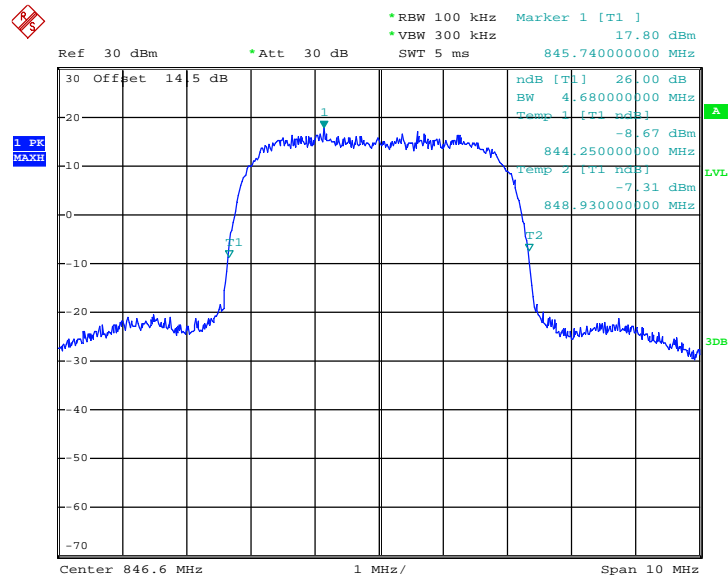

Date: 30.JUN.2015 23:56:52



Band :	WCDMA Band II	Test Mode :	RMC 12.2Kbps Link (QPSK)
--------	---------------	-------------	--------------------------

99% Occupied Bandwidth Plot on Channel 9262 (1852.4 MHz)

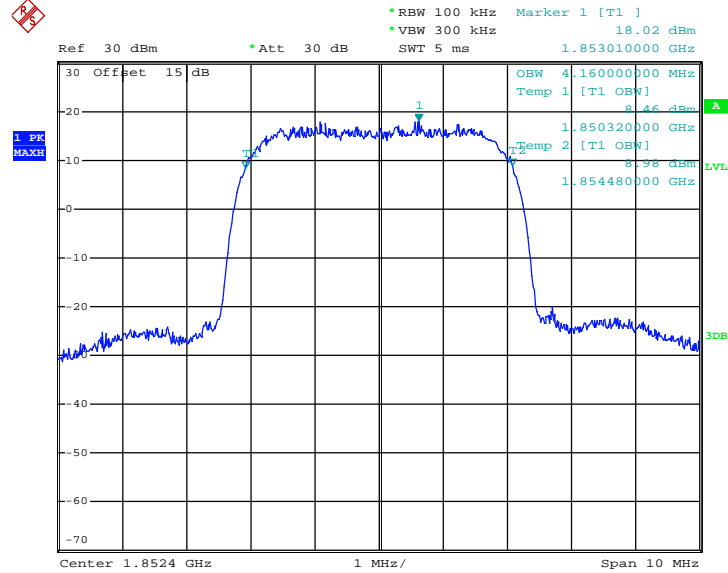

Date: 30.JUN.2015 23:38:48

26dB Bandwidth Plot on Channel 9262 (1852.4 MHz)

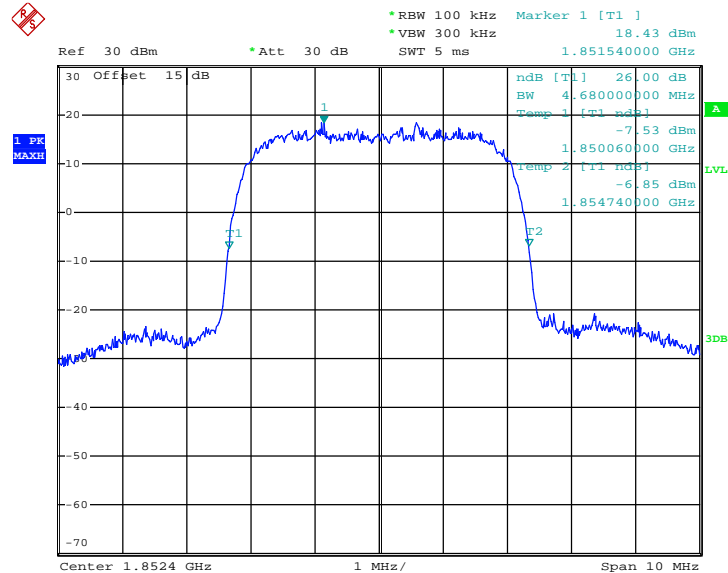

Date: 30.JUN.2015 23:28:59



99% Occupied Bandwidth Plot on Channel 9400 (1880.0 MHz)

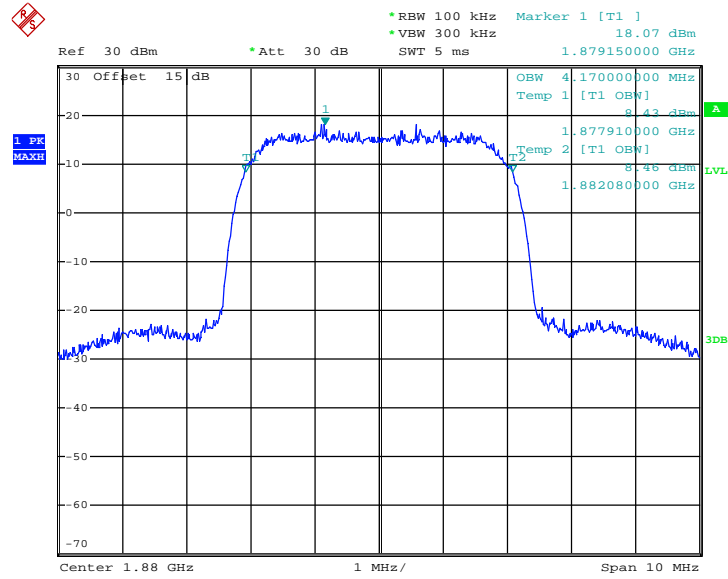

Date: 30.JUN.2015 23:40:27

26dB Bandwidth Plot on Channel 9400 (1880.0 MHz)

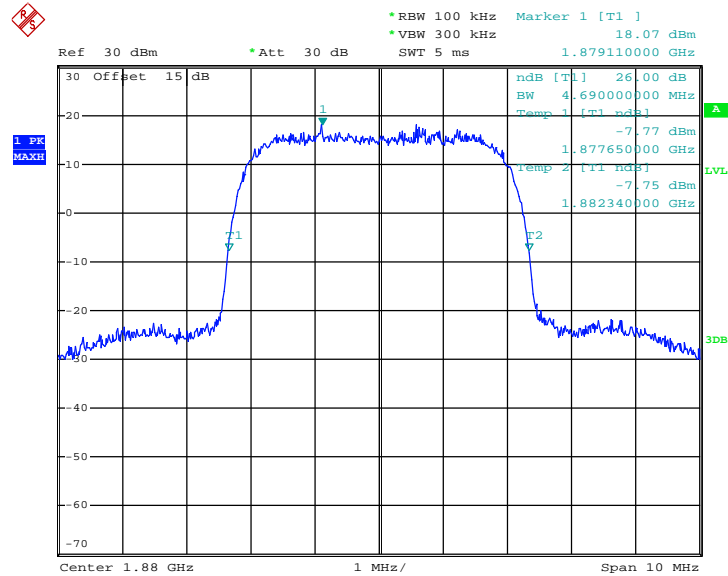

Date: 30.JUN.2015 23:29:35



99% Occupied Bandwidth Plot on Channel 9538 (1907.6 MHz)

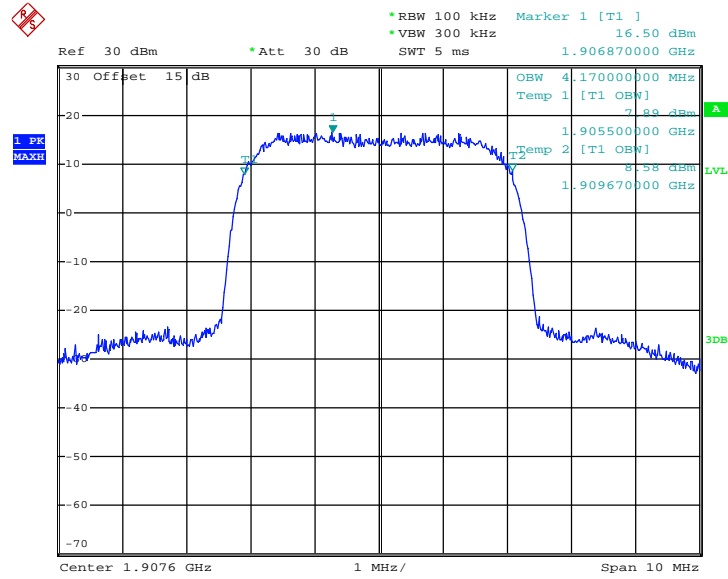

Date: 30.JUN.2015 23:41:10

26dB Bandwidth Plot on Channel 9538 (1907.6 MHz)

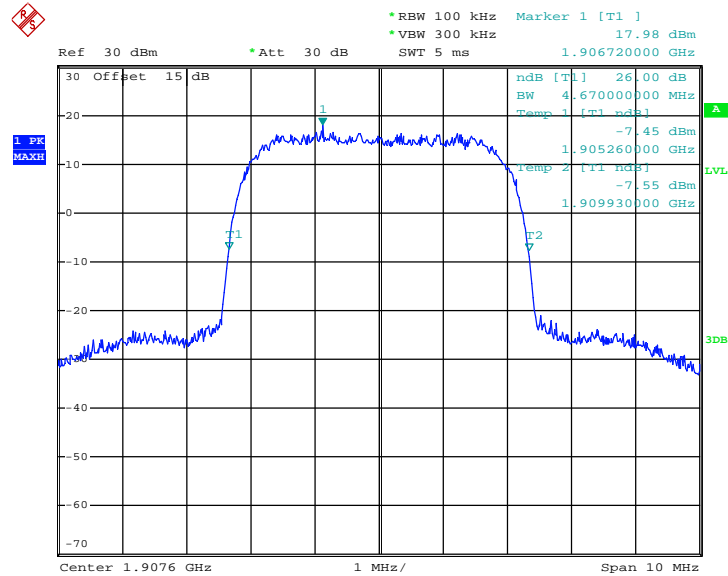

Date: 30.JUN.2015 23:30:35

3.5 Band Edge Measurement

3.5.1 Description of Band Edge Measurement

The power of any emission outside of the authorized operating frequency ranges must be lower than the transmitter power (P) by a factor of at least $43 + 10 \log (P)$ dB.

3.5.2 Measuring Instruments

The measuring equipment is listed in the section 4 of this test report.

3.5.3 Test Procedures

1. The testing follows FCC KDB 971168 v02r02 Section 6.0.
2. The EUT was connected to the spectrum analyzer and system simulator via a power divider.
3. The RF output of EUT was connected to the spectrum analyzer by an RF cable and attenuator. The path loss was compensated to the results for each measurement.
4. The band edges of low and high channels for the highest RF powers were measured.
5. The RF fundamental frequency should be excluded against the limit line in the operating frequency band.
6. The limit line is derived from $43 + 10\log(P)$ dB below the transmitter power P(Watts)
 $= P(W) - [43 + 10\log(P)] \text{ (dB)}$
 $= [30 + 10\log(P)] \text{ (dBm)} - [43 + 10\log(P)] \text{ (dB)}$
 $= -13\text{dBm}.$

3.5.4 Test Setup

<Conducted Band Edge >

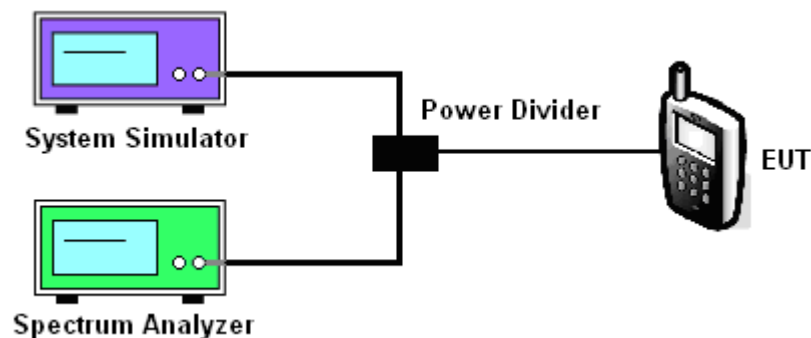



3.5.5 Test Result (Plots) of Conducted Band Edge

Band :	GSM850	Test Mode :	GSM Link (GMSK)
--------	--------	-------------	-----------------

Lower Band Edge Plot on Channel 128 (824.2 MHz)

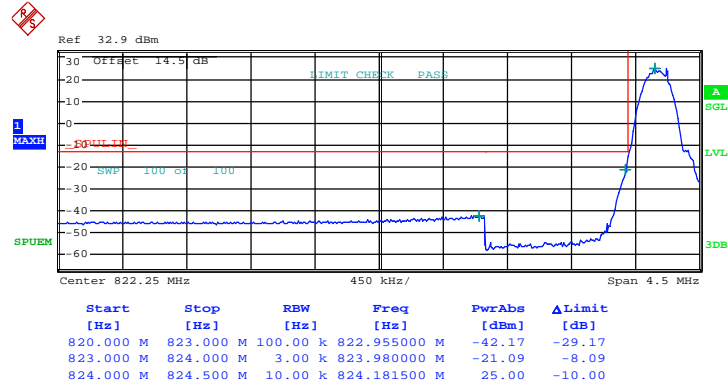

Date: 30.JUN.2015 22:42:32

Higher Band Edge Plot on Channel 251 (848.8 MHz)

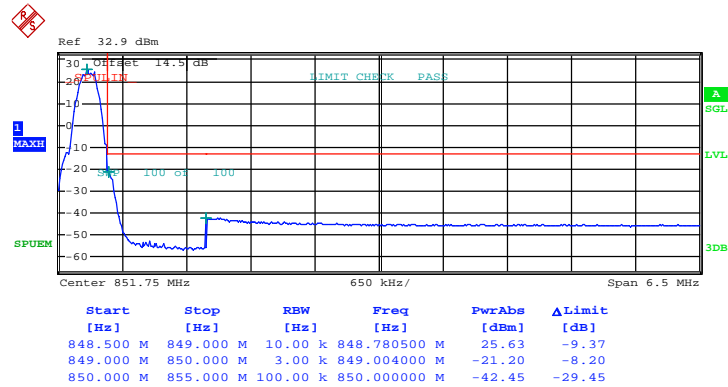

Date: 30.JUN.2015 22:47:11



Band :	GSM1900	Test Mode :	GSM Link (GMSK)
--------	---------	-------------	-----------------

Lower Band Edge Plot on Channel 512 (1850.2 MHz)

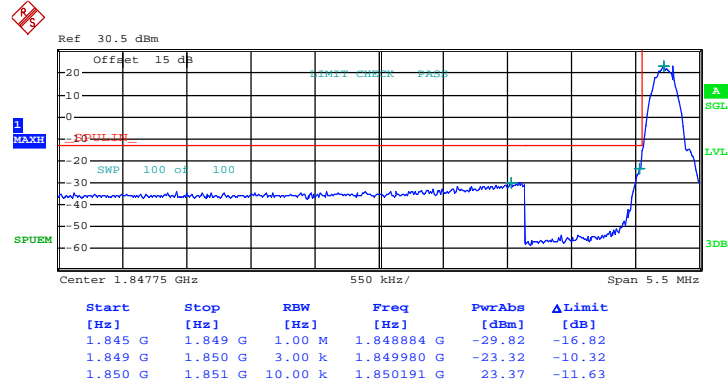

Date: 30.JUN.2015 23:13:18

Higher Band Edge Plot on Channel 810 (1909.8 MHz)

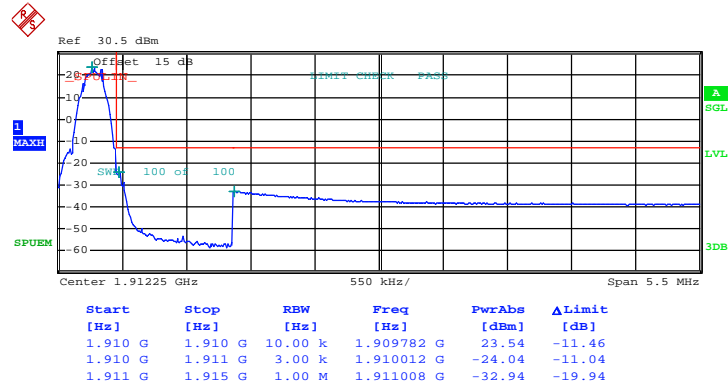

Date: 30.JUN.2015 23:18:05



Band :	WCDMA Band V	Test Mode :	RMC 12.2Kbps Link (QPSK)
--------	--------------	-------------	--------------------------

Lower Band Edge Plot on Channel 4132 (826.4 MHz)

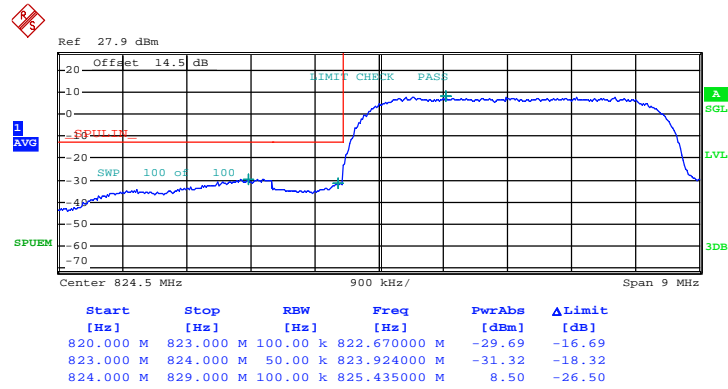

Date: 1.JUL.2015 00:04:22

Higher Band Edge Plot on Channel 4233 (846.6 MHz)

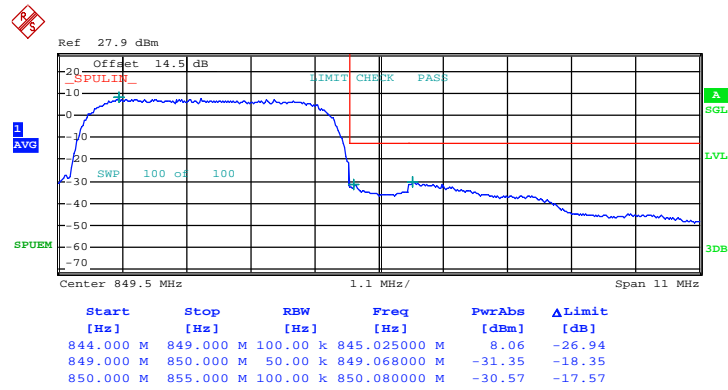

Date: 1.JUL.2015 00:09:49



Band :	WCDMA Band II	Test Mode :	RMC 12.2Kbps Link (QPSK)
--------	---------------	-------------	--------------------------

Lower Band Edge Plot on Channel 9262 (1852.4 MHz)

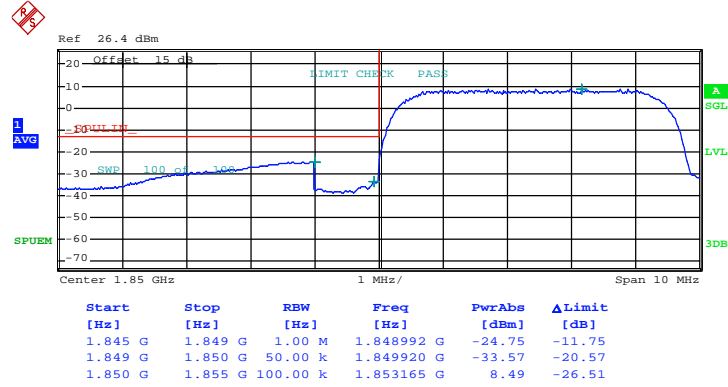

Date: 30.JUN.2015 23:47:30

Higher Band Edge Plot on Channel 9538 (1907.6 MHz)

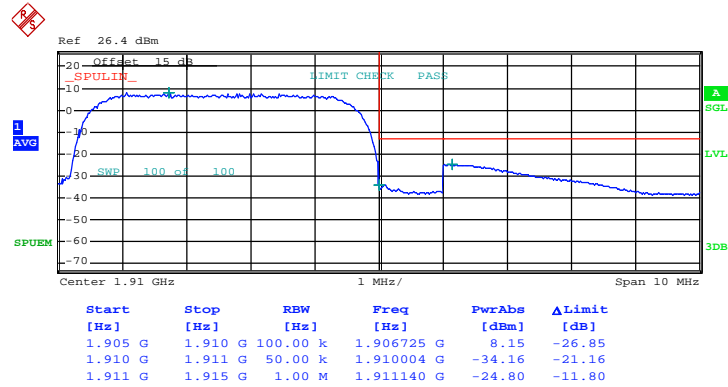

Date: 30.JUN.2015 23:51:31

3.6 Conducted Spurious Emission Measurement

3.6.1 Description of Conducted Spurious Emission Measurement

The power of any emission outside of the authorized operating frequency ranges must be lower than the transmitter power (P) by a factor of at least $43 + 10 \log (P)$ dB.

It is measured by means of a calibrated spectrum analyzer and scanned from 30 MHz up to a frequency including its 10th harmonic.

3.6.2 Measuring Instruments

The measuring equipment is listed in the section 4 of this test report.

3.6.3 Test Procedures

1. The testing follows FCC KDB 971168 v02r02 Section 6.0.
2. The EUT was connected to the spectrum analyzer and system simulator via a power divider.
3. The RF output of EUT was connected to the spectrum analyzer by an RF cable and attenuator. The path loss was compensated to the results for each measurement.
4. The middle channel for the highest RF power within the transmitting frequency was measured.
5. The conducted spurious emission for the whole frequency range was taken.
6. The RF fundamental frequency should be excluded against the limit line in the operating frequency band.
7. The limit line is derived from $43 + 10\log(P)$ dB below the transmitter power P(Watts)
 $= P(W) - [43 + 10\log(P)]$ (dB)
 $= [30 + 10\log(P)]$ (dBm) - $[43 + 10\log(P)]$ (dB)
 $= -13\text{dBm}$.

3.6.4 Test Setup

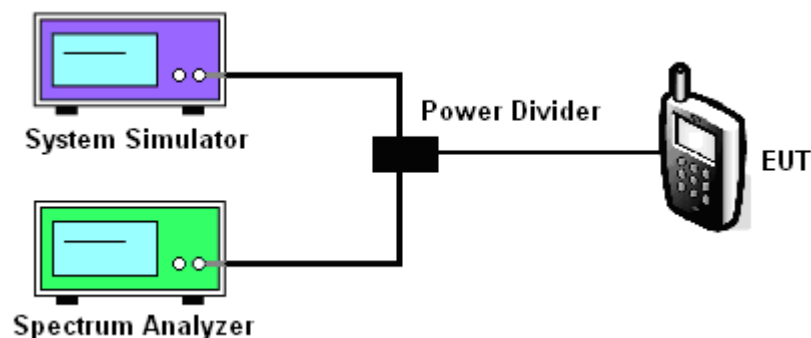



3.6.5 Test Result (Plots) of Conducted Spurious Emission

Band :	GSM850	Channel :	CH189
Test Mode :	GSM Link (GMSK)	Frequency :	836.4 MHz

Conducted Spurious Emission Plot between 30MHz ~ 9GHz

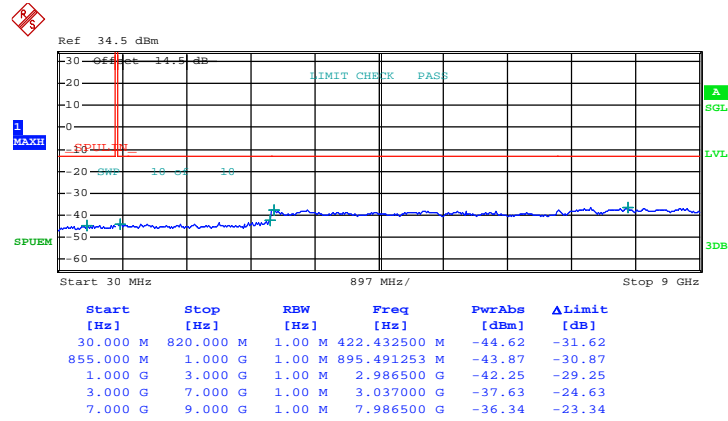

Date: 30.JUN.2015 22:49:47



Band :	GSM1900	Channel :	CH661
Test Mode :	GSM Link (GMSK)	Frequency :	1880.0 MHz

Conducted Spurious Emission Plot between 30MHz ~ 19.1GHz

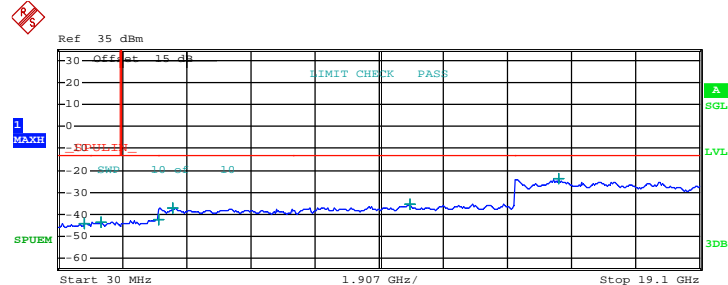

Start [Hz]	Stop [Hz]	RBW [Hz]	Freq [Hz]	PwrAbs [dBm]	ΔLimit [dB]
30.000 M	1.000 G	1.00 M	791.692500 M	-44.01	-31.01
1.000 G	1.845 G	1.00 M	1.279695 G	-43.46	-30.46
1.915 G	3.000 G	1.00 M	2.997288 G	-42.46	-29.46
3.000 G	7.000 G	1.00 M	3.441000 G	-37.13	-24.13
7.000 G	13.600 G	1.00 M	10.471600 G	-35.48	-22.48
13.600 G	19.100 G	1.00 M	14.913813 G	-23.67	-10.67

Date: 30.JUN.2015 23:19:44



Band :	WCDMA Band V	Channel :	CH4182
Test Mode :	RMC 12.2Kbps Link (QPSK)	Frequency :	836.4 MHz

Conducted Spurious Emission Plot between 30MHz ~ 9GHz

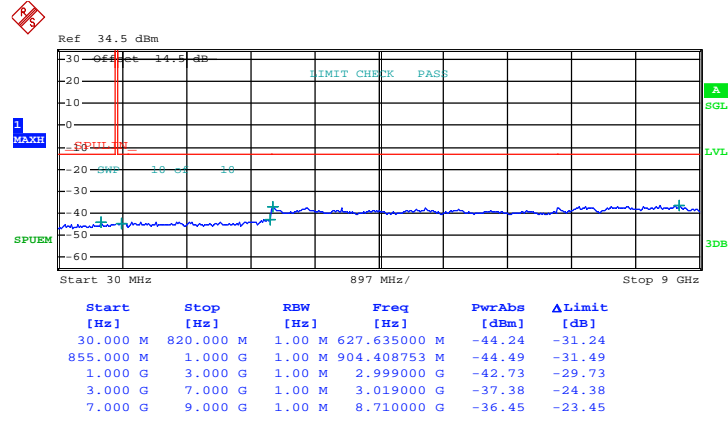

Date: 1.JUL.2015 00:11:53



Band :	WCDMA Band II	Channel :	CH9400
Test Mode :	RMC 12.2Kbps Link (QPSK)	Frequency :	1880.0 MHz

Conducted Spurious Emission Plot between 30MHz ~ 19.1GHz

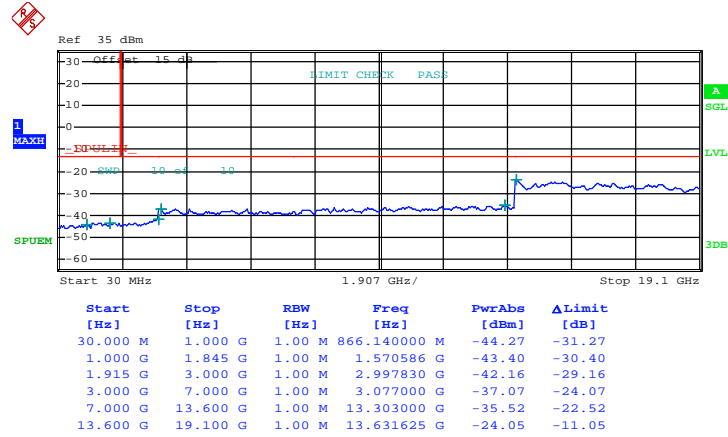

Date: 30.JUN.2015 23:26:55



3.7 Field Strength of Spurious Radiation Measurement

3.7.1 Description of Field Strength of Spurious Radiated Measurement

The power of any emission outside of the authorized operating frequency ranges must be attenuated below the transmitter power (P) by a factor of at least $43 + 10 \log (P)$ dB. The spectrum is scanned from 30 MHz up to a frequency including its 10th harmonic.

3.7.2 Measuring Instruments

The measuring equipment is listed in the section 4 of this test report.

3.7.3 Test Procedures

1. The testing follows FCC KDB 971168 v02r02 Section 5.8 and ANSI / TIA-603-C-2004 Section 2.2.12.
2. The EUT was placed on a rotatable wooden table 0.8 meters above the ground.
3. The EUT was set 3 meters from the receiving antenna, which was mounted on the antenna tower.
4. The table was rotated 360 degrees to determine the position of the highest spurious emission.
5. The height of the receiving antenna is varied between one meter and four meters to search for the maximum spurious emission for both horizontal and vertical polarizations.
6. Make the measurement with the spectrum analyzer's RBW = 1MHz, VBW = 3MHz, taking record of maximum spurious emission.
7. A horn antenna was substituted in place of the EUT and was driven by a signal generator.
8. Tune the output power of signal generator to the same emission level with EUT maximum spurious emission.
9. Taking the record of output power at antenna port.
10. Repeat step 7 to step 8 for another polarization.
11. $EIRP (dBm) = S.G. Power - Tx Cable Loss + Tx Antenna Gain$
12. $ERP (dBm) = EIRP - 2.15$
13. The RF fundamental frequency should be excluded against the limit line in the operating frequency band.
14. The limit line is derived from $43 + 10\log(P)$ dB below the transmitter power P(Watts)
= $P(W) - [43 + 10\log(P)] (dB)$
= $[30 + 10\log(P)] (dBm) - [43 + 10\log(P)] (dB)$
= -13dBm.

3.7.4 Test Setup

For radiated emissions from 30MHz to 1GHz

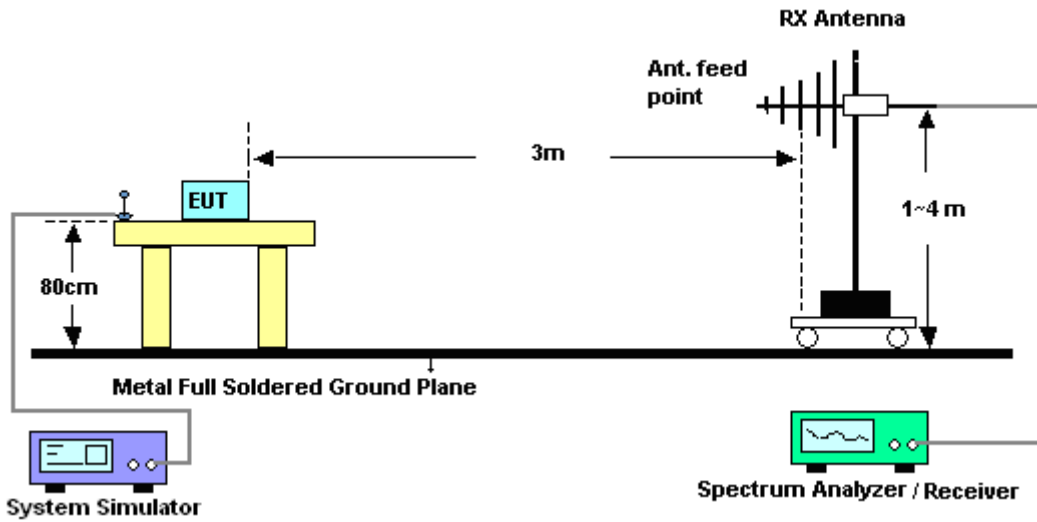

For radiated emissions above 1GHz

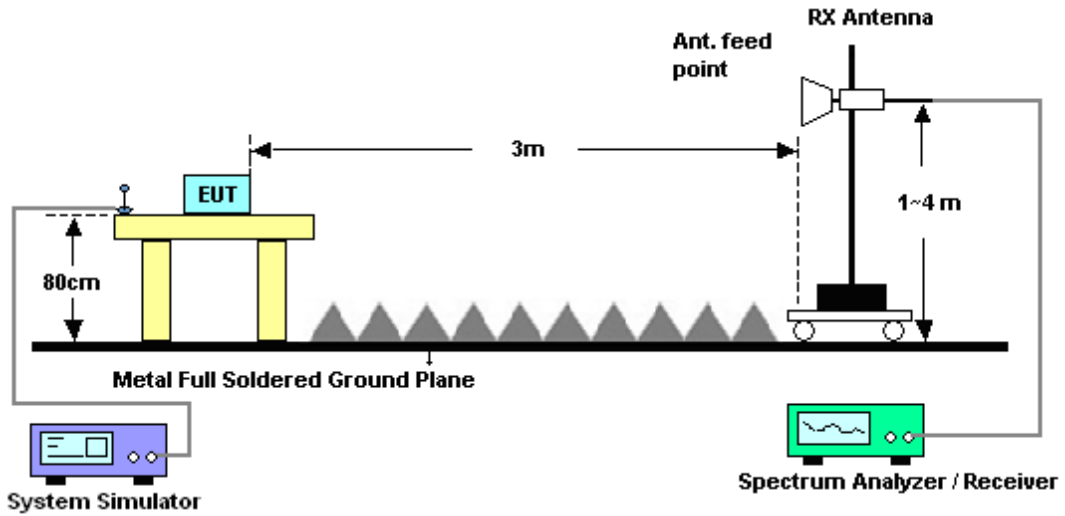



3.7.5 Test Result of Field Strength of Spurious Radiated

Band :	GSM850				Temperature :	23~25°C			
Test Mode :	GSM Link (GMSK)				Relative Humidity :	48~52%			
Test Engineer :	Brank You				Polarization :	Horizontal			
Remark :	Spurious emissions within 30-1000MHz were found more than 20dB below limit line.								
Frequency (MHz)	ERP (dBm)	Limit (dBm)	Over Limit (dB)	SPA Reading (dBm)	S.G. Power (dBm)	TX Cable loss (dB)	TX Antenna Gain (dBi)	Polarization (H/V)	Result
1672	-47.27	-13	-34.27	-50.10	-53.96	0.56	9.40	H	Pass
2510	-48.59	-13	-35.59	-53.50	-56.29	0.75	10.60	H	Pass
3346	-43.44	-13	-30.44	-54.03	-53.04	0.85	12.60	H	Pass
4182	-43.45	-13	-30.45	-54.43	-53.01	0.89	12.60	H	Pass

Band :	GSM850				Temperature :	23~25°C			
Test Mode :	GSM Link (GMSK)				Relative Humidity :	48~52%			
Test Engineer :	Brank You				Polarization :	Vertical			
Remark :	Spurious emissions within 30-1000MHz were found more than 20dB below limit line.								
Frequency (MHz)	ERP (dBm)	Limit (dBm)	Over Limit (dB)	SPA Reading (dBm)	S.G. Power (dBm)	TX Cable loss (dB)	TX Antenna Gain (dBi)	Polarization (H/V)	Result
1672	-42.06	-13	-29.06	-47.47	-48.75	0.56	9.40	V	Pass
2510	-52.82	-13	-39.82	-57.29	-60.52	0.75	10.60	V	Pass
3346	-41.86	-13	-28.86	-51.33	-51.46	0.85	12.60	V	Pass
4182	-46.28	-13	-33.28	-56.57	-55.84	0.89	12.60	V	Pass



Band :	GSM1900		Temperature :	23~25°C					
Test Mode :	GSM Link (GMSK)		Relative Humidity :	48~52%					
Test Engineer :	Brank You		Polarization :	Horizontal					
Remark :	Spurious emissions within 30-1000MHz were found more than 20dB below limit line.								
Frequency (MHz)	EIRP (dBm)	Limit (dBm)	Over Limit (dB)	SPA Reading (dBm)	S.G. Power (dBm)	TX Cable loss (dB)	TX Antenna Gain (dBi)	Polarization (H/V)	Result
3760	-44.30	-13	-31.30	-55.55	-56.03	0.87	12.60	H	Pass
5640	-51.55	-13	-38.55	-67.43	-63.58	1.07	13.10	H	Pass
7520	-49.51	-13	-36.51	-67.83	-59.12	1.69	11.30	H	Pass

Band :	GSM1900		Temperature :	23~25°C					
Test Mode :	GSM Link (GMSK)		Relative Humidity :	48~52%					
Test Engineer :	Brank You		Polarization :	Vertical					
Remark :	Spurious emissions within 30-1000MHz were found more than 20dB below limit line.								
Frequency (MHz)	EIRP (dBm)	Limit (dBm)	Over Limit (dB)	SPA Reading (dBm)	S.G. Power (dBm)	TX Cable loss (dB)	TX Antenna Gain (dBi)	Polarization (H/V)	Result
3760	-45.36	-13	-32.36	-57.83	-57.09	0.87	12.6	V	Pass
5640	-49.90	-13	-36.90	-66.22	-61.93	1.07	13.1	V	Pass
7520	-49.35	-13	-36.35	-67.57	-58.96	1.69	11.3	V	Pass



Band :	WCDMA Band V	Temperature :	23~25°C						
Test Mode :	RMC 12.2Kbps Link (QPSK)	Relative Humidity :	48~52%						
Test Engineer :	Brank You	Polarization :	Horizontal						
Remark :	Spurious emissions within 30-1000MHz were found more than 20dB below limit line.								
Frequency (MHz)	ERP (dBm)	Limit (dBm)	Over Limit (dB)	SPA Reading (dBm)	S.G. Power (dBm)	TX Cable loss (dB)	TX Antenna Gain (dBi)	Polarization (H/V)	Result
1672	-61.29	-13	-48.29	-62.90	-67.98	0.56	9.40	H	Pass
2510	-60.68	-13	-47.68	-64.58	-68.38	0.75	10.60	H	Pass
3346	-56.65	-13	-43.65	-65.95	-66.25	0.85	12.60	H	Pass
4182	-56.51	-13	-43.51	-67.33	-66.07	0.89	12.60	H	Pass

Band :	WCDMA Band V	Temperature :	23~25°C						
Test Mode :	RMC 12.2Kbps Link (QPSK)	Relative Humidity :	48~52%						
Test Engineer :	Brank You	Polarization :	Vertical						
Remark :	Spurious emissions within 30-1000MHz were found more than 20dB below limit line.								
Frequency (MHz)	ERP (dBm)	Limit (dBm)	Over Limit (dB)	SPA Reading (dBm)	S.G. Power (dBm)	TX Cable loss (dB)	TX Antenna Gain (dBi)	Polarization (H/V)	Result
1672	-59.73	-13	-46.73	-62.18	-66.42	0.56	9.40	V	Pass
2510	-60.11	-13	-47.11	-64.49	-67.81	0.75	10.60	V	Pass
3346	-58.82	-13	-45.82	-65.68	-68.42	0.85	12.60	V	Pass
4182	-56.56	-13	-43.56	-66.85	-66.12	0.89	12.60	V	Pass



Band :	WCDMA Band II	Temperature :	23~25°C						
Test Mode :	RMC 12.2Kbps Link (QPSK)	Relative Humidity :	48~52%						
Test Engineer :	Brank You	Polarization :	Horizontal						
Remark :	Spurious emissions within 30-1000MHz were found more than 20dB below limit line.								
Frequency (MHz)	EIRP (dBm)	Limit (dBm)	Over Limit (dB)	SPA Reading (dBm)	S.G. Power (dBm)	TX Cable loss (dB)	TX Antenna Gain (dBi)	Polarization (H/V)	Result
3760	-51.70	-13	-38.70	-62.95	-63.43	0.87	12.60	H	Pass
5640	-52.32	-13	-39.32	-68.20	-64.35	1.07	13.10	H	Pass
7520	-49.59	-13	-36.59	-67.91	-59.20	1.69	11.30	H	Pass

Band :	WCDMA Band II	Temperature :	23~25°C						
Test Mode :	RMC 12.2Kbps Link (QPSK)	Relative Humidity :	48~52%						
Test Engineer :	Brank You	Polarization :	Vertical						
Remark :	Spurious emissions within 30-1000MHz were found more than 20dB below limit line.								
Frequency (MHz)	EIRP (dBm)	Limit (dBm)	Over Limit (dB)	SPA Reading (dBm)	S.G. Power (dBm)	TX Cable loss (dB)	TX Antenna Gain (dBi)	Polarization (H/V)	Result
3760	-51.35	-13	-38.35	-63.82	-63.08	0.87	12.6	V	Pass
5640	-51.73	-13	-38.73	-68.05	-63.76	1.07	13.1	V	Pass
7520	-49.57	-13	-36.57	-67.79	-59.18	1.69	11.3	V	Pass

3.8 Frequency Stability Measurement

3.8.1 Description of Frequency Stability Measurement

The frequency stability shall be measured by variation of ambient temperature and variation of primary supply voltage to ensure that the fundamental emission stays within the authorized frequency block. The frequency stability of the transmitter shall be maintained within $\pm 0.00025\%$ ($\pm 2.5\text{ppm}$) of the center frequency.

3.8.2 Measuring Instruments

The measuring equipment is listed in the section 4 of this test report.

3.8.3 Test Procedures for Temperature Variation

1. The testing follows FCC KDB 971168 v02r02 Section 9.0.
2. The EUT was set up in the thermal chamber and connected with the system simulator.
3. With power OFF, the temperature was decreased to -30°C and the EUT was stabilized before testing. Power was applied and the maximum change in frequency was recorded within one minute.
4. With power OFF, the temperature was raised in 10°C steps up to 50°C . The EUT was stabilized at each step for at least half an hour. Power was applied and the maximum frequency change was recorded within one minute.

3.8.4 Test Procedures for Voltage Variation

1. The testing follows FCC KDB 971168 v02r02 Section 9.0.
2. The EUT was placed in a temperature chamber at $25\pm 5^{\circ}\text{C}$ and connected with the system simulator.
3. The power supply voltage to the EUT was varied from BEP to 115% of the nominal value measured at the input to the EUT.
4. The variation in frequency was measured for the worst case.

3.8.5 Test Setup

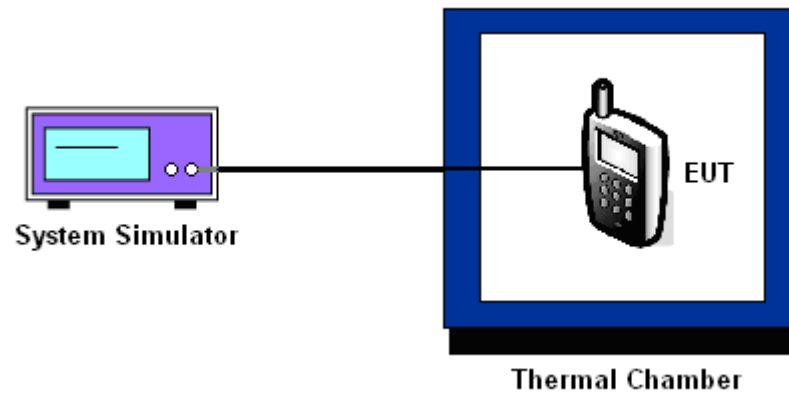



3.8.6 Test Result of Temperature Variation

Band :	GSM 850	Channel :	189
Limit (ppm) :	2.5	Frequency :	836.4 MHz

Temperature (°C)	GSM		Result
	Deviation (ppm)		
50	0.0096		PASS
40	0.0060		
30	0.0024		
20(Ref.)	0.0000		
10	0.0024		
0	0.0060		
-10	0.0096		
-20	0.0143		
-30	0.0191		

Band :	GSM 1900	Channel :	661
Limit (ppm) :	within authorized band	Frequency :	1880.0 MHz

Temperature (°C)	GSM		Result
	Deviation (ppm)		
50	0.0043		PASS
40	0.0032		
30	0.0016		
20(Ref.)	0.0000		
10	0.0011		
0	0.0027		
-10	0.0037		
-20	0.0048		
-30	0.0064		

Note: The frequency fundamental emissions stay within the authorized frequency block based on the frequency deviation measured is small.



Band :	WCDMA Band V	Channel :	4182
Limit (ppm) :	2.5	Frequency :	836.4 MHz

Temperature (°C)	RMC 12.2Kbps		Result
	Deviation (ppm)		
50	0.0024		PASS
40	0.0012		
30	0.0012		
20(Ref.)	0.0000		
10	0.0012		
0	0.0024		
-10	0.0036		
-20	0.0060		
-30	0.0072		

Band :	WCDMA Band II	Channel :	9400
Limit (ppm) :	within authorized band	Frequency :	1880.0 MHz

Temperature (°C)	RMC 12.2Kbps		Result
	Deviation (ppm)		
50	0.0011		PASS
40	0.0005		
30	0.0005		
20(Ref.)	0.0000		
10	0.0005		
0	0.0005		
-10	0.0011		
-20	0.0016		
-30	0.0021		

Note: The frequency fundamental emissions stay within the authorized frequency block based on the frequency deviation measured is small.



3.8.7 Test Result of Voltage Variation

Band & Channel	Mode	Voltage (Volt)	Deviation (ppm)	Limit (ppm)	Result
GSM 850 CH189	GSM	4.2	0.0012	2.5	PASS
		3.8	0.0000		
		BEP	0.0012		
GSM 1900 CH661	GSM	4.2	0.0011	(Note 3.)	
		3.8	0.0000		
		BEP	0.0016		
WCDMA Band V CH4182	RMC 12.2Kbps	4.2	0.0024	2.5	
		3.8	0.0012		
		BEP	0.0000		
WCDMA Band II CH9400	RMC 12.2Kbps	4.2	0.0005	(Note 3.)	
		3.8	0.0000		
		BEP	0.0005		

Note:

1. Normal Voltage = 3.8V.
2. Battery End Point (BEP) = 3.4 V.
3. The frequency fundamental emissions stay within the authorized frequency block based on the frequency deviation measured is small.



4 List of Measuring Equipment

Instrument	Manufacturer	Model No.	Serial No.	Characteristics	Calibration Date	Test Date	Due Date	Remark
Spectrum Analyzer	R&S	FSV40	101078	9kHz~40GHz	May 05, 2015	Jun. 29, 2015~ Jul. 01, 2015	May 04, 2016	Conducted (TH01-SZ)
Spectrum Analyzer	R&S	FSP30	101400	9kHz~30GHz	Jan. 28, 2015	Jun. 29, 2015~ Jul. 01, 2015	Jan. 27, 2016	Conducted (TH01-SZ)
Thermal Chamber	Ten Billion	LP-150U	H2014081803	-40~+150°C	Sep. 16, 2014	Jun. 29, 2015~ Jul. 01, 2015	Sep. 15, 2015	Conducted (TH01-SZ)
EMI Test Receiver&SA	Agilent Technologies	N9038A	MY52260185	20Hz~26.5GHz	May 26, 2015	Jul. 28, 2015	May 25, 2016	Radiation (03CH01-SZ)
Spectrum Analyzer	R&S	FSV40	101041	10kHz~40GHz;Ma x 30dBm	Sep. 25, 2014	Jul. 28, 2015	Sep. 24, 2015	Radiation (03CH01-SZ)
Bilog Antenna	TeseQ	CBL6112D	23188	30MHz~2GHz	Nov. 07, 2014	Jul. 28, 2015	Nov. 06, 2015	Radiation (03CH01-SZ)
Double Ridge Horn Antenna	ETS-Lindgren	3117	00119436	1GHz~18GHz	Oct. 15, 2014	Jul. 28, 2015	Oct. 14, 2015	Radiation (03CH01-SZ)
SHF-EHF Horn	com-power	AH-840	101071	18GHz~40GHz	Sep. 04, 2014	Jul. 28, 2015	Sep. 03, 2015	Radiation (03CH01-SZ)
Amplifier	ADVANTEST	BB525C	E9007003	9kHz~3000MHz / 30 dB	Jan. 28, 2015	Jul. 28, 2015	Jan. 27, 2016	Radiation (03CH01-SZ)
Amplifier	Yiai	AV3860B	04030	2GHz~26.5GHz	May 05, 2015	Jul. 28, 2015	May 04, 2016	Radiation (03CH01-SZ)
Amplifier	Agilent Technologies	83017A	MY39501302	500MHz~26.5GHz	Jan. 28, 2015	Jul. 28, 2015	Jan. 27, 2016	Radiation (03CH01-SZ)
AC Power Source	Chroma	61601	61601000198 5	N/A	NCR	Jul. 28, 2015	NCR	Radiation (03CH01-SZ)
Turn Table	EM	EM1000	N/A	0~360 degree	NCR	Jul. 28, 2015	NCR	Radiation (03CH01-SZ)
Antenna Mast	EM	EM1000	N/A	1 m~4 m	NCR	Jul. 28, 2015	NCR	Radiation (03CH01-SZ)



5 Uncertainty of Evaluation

Uncertainty of Radiated Emission Measurement (30 MHz ~ 1000 MHz)

Measuring Uncertainty for a Level of Confidence of 95% ($U = 2Uc(y)$)	3.9dB
---	-------