



Appendix A. SAR Plots of System Verification

The plots for system verification are shown as follows.

System Check_H835_121024

DUT: Dipole 835 MHz; Type: D835V2; SN: 4d139

Communication System: CW; Frequency: 835 MHz; Duty Cycle: 1:1

Medium: H835_1024 Medium parameters used: $f = 835$ MHz; $\sigma = 0.910$ mho/m; $\epsilon_r = 42.116$; $\rho = 1000$ kg/m³

Ambient Temperature : 21.7 °C; Liquid Temperature : 20.6 °C

DASY5 Configuration:

- Probe: EX3DV4 - SN3873; ConvF(9.13, 9.13, 9.13); Calibrated: 2012/08/06;
- Sensor-Surface: 2mm (Mechanical Surface Detection)
- Electronics: DAE4 Sn1341; Calibrated: 2012/08/07
- Phantom: Right Phantom with CRP v5.0; Type: QD000P40CD; Serial: TP:1722
- Measurement SW: DASY52, Version 52.8 (3); SEMCAD X Version 14.6.7 (6848)

Pin=250mW/Area Scan (61x101x1): Measurement grid: dx=15mm, dy=15mm

Maximum value of SAR (interpolated) = 3.08 W/kg

Pin=250mW/Zoom Scan (5x5x7)/Cube 0: Measurement grid: dx=8mm, dy=8mm, dz=5mm

Reference Value = 59.705 V/m; Power Drift = 0.04 dB

Peak SAR (extrapolated) = 3.66 W/kg

SAR(1 g) = 2.51 W/kg; SAR(10 g) = 1.68 W/kg

Maximum value of SAR (measured) = 3.16 W/kg

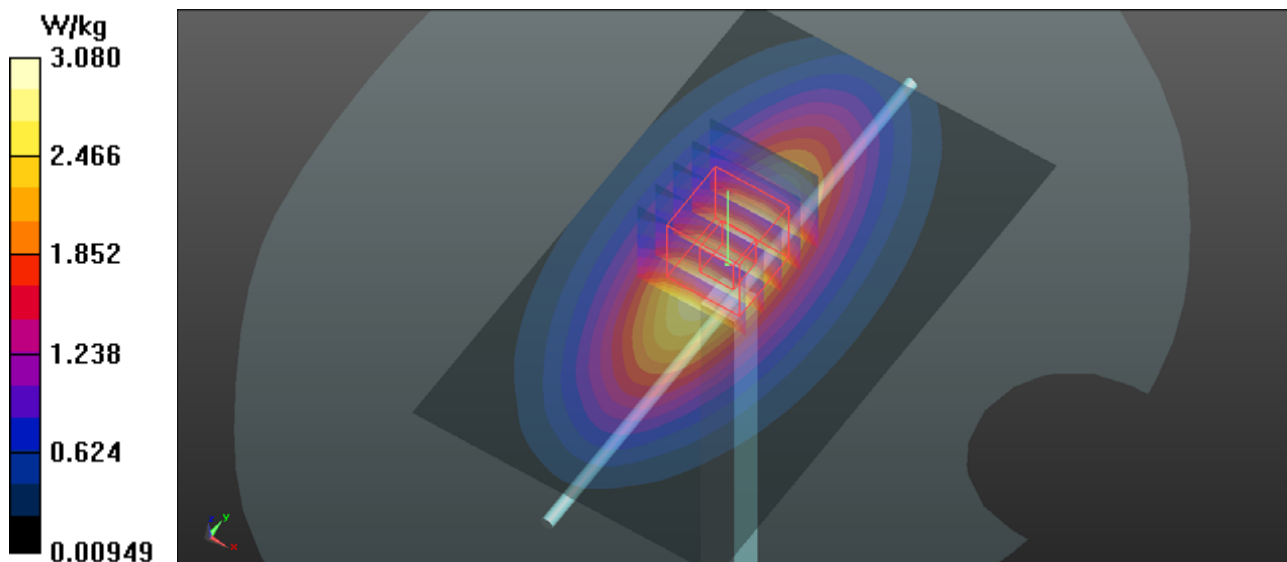

System Check_H835_121106

DUT: Dipole 835 MHz; Type: D835V2; SN: 4d139

Communication System: CW; Frequency: 835 MHz; Duty Cycle: 1:1

Medium: H835_1106 Medium parameters used: $f = 835$ MHz; $\sigma = 0.898$ mho/m; $\epsilon_r = 40.597$; $\rho = 1000$ kg/m³

Ambient Temperature : 22.2 °C ; Liquid Temperature : 21.1 °C

DASY5 Configuration:

- Probe: EX3DV4 - SN3873; ConvF(9.13, 9.13, 9.13); Calibrated: 2012/08/06;
- Sensor-Surface: 2mm (Mechanical Surface Detection)
- Electronics: DAE4 Sn1341; Calibrated: 2012/08/07
- Phantom: Front Phantom with CRP v5.0; Type: QD000P40CD; Serial: TP:1695
- Measurement SW: DASY52, Version 52.8 (3); SEMCAD X Version 14.6.7 (6848)

Pin=250mW/Area Scan (61x101x1): Measurement grid: dx=15mm, dy=15mm

Maximum value of SAR (interpolated) = 3.04 W/kg

Pin=250mW/Zoom Scan (5x5x7)/Cube 0: Measurement grid: dx=8mm, dy=8mm, dz=5mm

Reference Value = 59.705 V/m; Power Drift = 0.03 dB

Peak SAR (extrapolated) = 3.62 W/kg

SAR(1 g) = 2.48 W/kg; SAR(10 g) = 1.66 W/kg

Maximum value of SAR (measured) = 3.11 W/kg

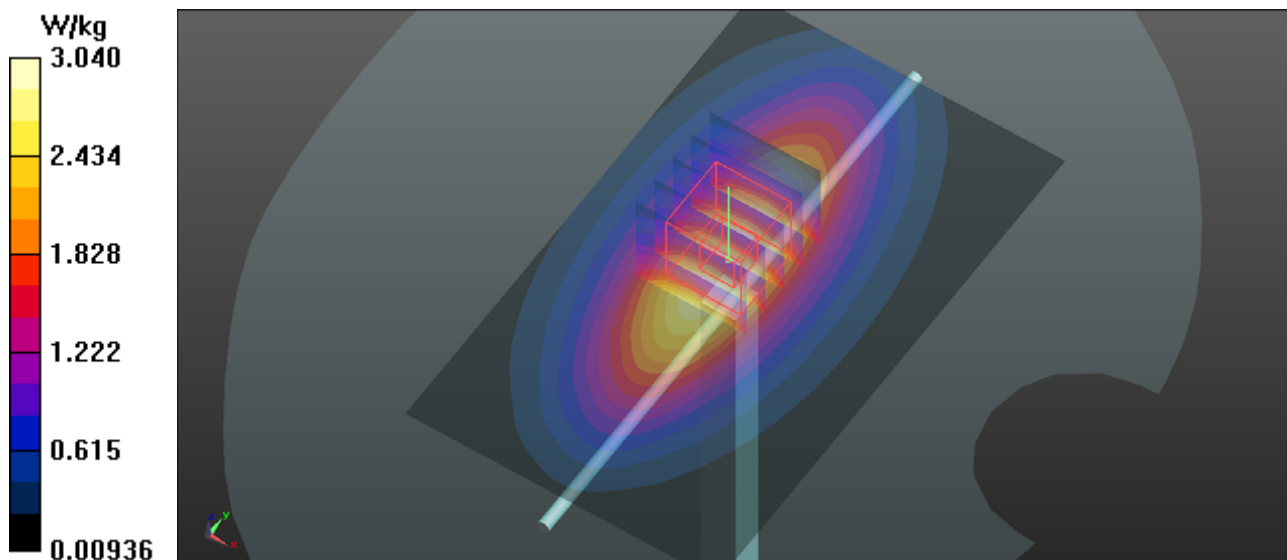

System Check_H1900_121025

DUT: Dipole 1900 MHz; Type: D1900V2; SN: 5d159

Communication System: CW; Frequency: 1900 MHz; Duty Cycle: 1:1

Medium: H1900_1025 Medium parameters used: $f = 1900$ MHz; $\sigma = 1.425$ mho/m; $\epsilon_r = 41.558$; $\rho = 1000$ kg/m³

Ambient Temperature : 21.9°C; Liquid Temperature : 20.9 °C

DASY5 Configuration:

- Probe: EX3DV4 - SN3873; ConvF(7.74, 7.74, 7.74); Calibrated: 2012/08/06;
- Sensor-Surface: 2mm (Mechanical Surface Detection)
- Electronics: DAE4 Sn1341; Calibrated: 2012/08/07
- Phantom: Front Phantom with CRP v5.0; Type: QD000P40CD; Serial: TP:1695
- Measurement SW: DASY52, Version 52.8 (3); SEMCAD X Version 14.6.7 (6848)

Pin=250mW/Area Scan (61x61x1): Measurement grid: dx=15mm, dy=15mm

Maximum value of SAR (interpolated) = 14.1 W/kg

Pin=250mW/Zoom Scan (5x5x7)/Cube 0: Measurement grid: dx=8mm, dy=8mm, dz=5mm

Reference Value = 95.476 V/m; Power Drift = 0.01 dB

Peak SAR (extrapolated) = 17.1 W/kg

SAR(1 g) = 9.66 W/kg; SAR(10 g) = 5.07 W/kg

Maximum value of SAR (measured) = 13.7 W/kg

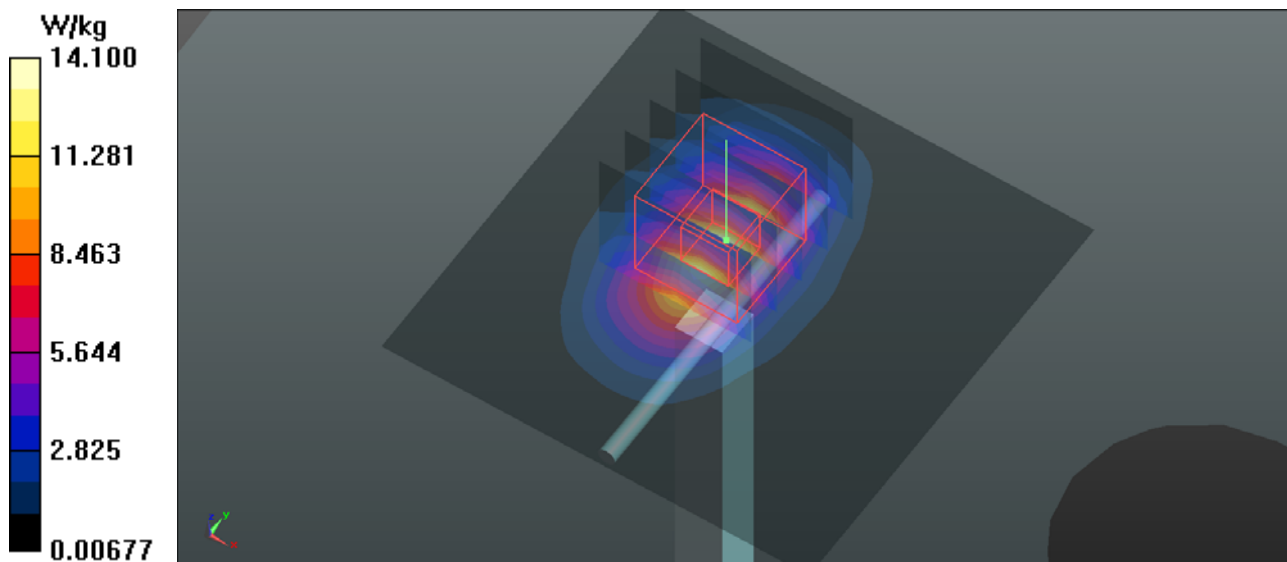

System Check_H2450_121025

DUT: Dipole 2450 MHz; Type: D2450V2; SN: 893

Communication System: CW; Frequency: 2450 MHz; Duty Cycle: 1:1

Medium: H2450_1025 Medium parameters used: $f = 2450$ MHz; $\sigma = 1.85$ mho/m; $\epsilon_r = 40.901$; $\rho = 1000$ kg/m³

Ambient Temperature : 21.8 °C ; Liquid Temperature : 20.9 °C

DASY5 Configuration:

- Probe: EX3DV4 - SN3873; ConvF(6.91, 6.91, 6.91); Calibrated: 2012/08/06;
- Sensor-Surface: 2mm (Mechanical Surface Detection)
- Electronics: DAE4 Sn1341; Calibrated: 2012/08/07
- Phantom: Right Phantom with CRP v5.0; Type: QD000P40CD; Serial: TP:1722
- Measurement SW: DASY52, Version 52.8 (3); SEMCAD X Version 14.6.7 (6848)

Pin=250mW/Area Scan (61x61x1): Measurement grid: dx=15mm, dy=15mm

Maximum value of SAR (interpolated) = 19.9 W/kg

Pin=250mW/Zoom Scan (5x5x7)/Cube 0: Measurement grid: dx=8mm, dy=8mm, dz=5mm

Reference Value = 101.4 V/m; Power Drift = -0.02 dB

Peak SAR (extrapolated) = 26.9 W/kg

SAR(1 g) = 12.8 W/kg; SAR(10 g) = 5.84 W/kg

Maximum value of SAR (measured) = 19.7 W/kg

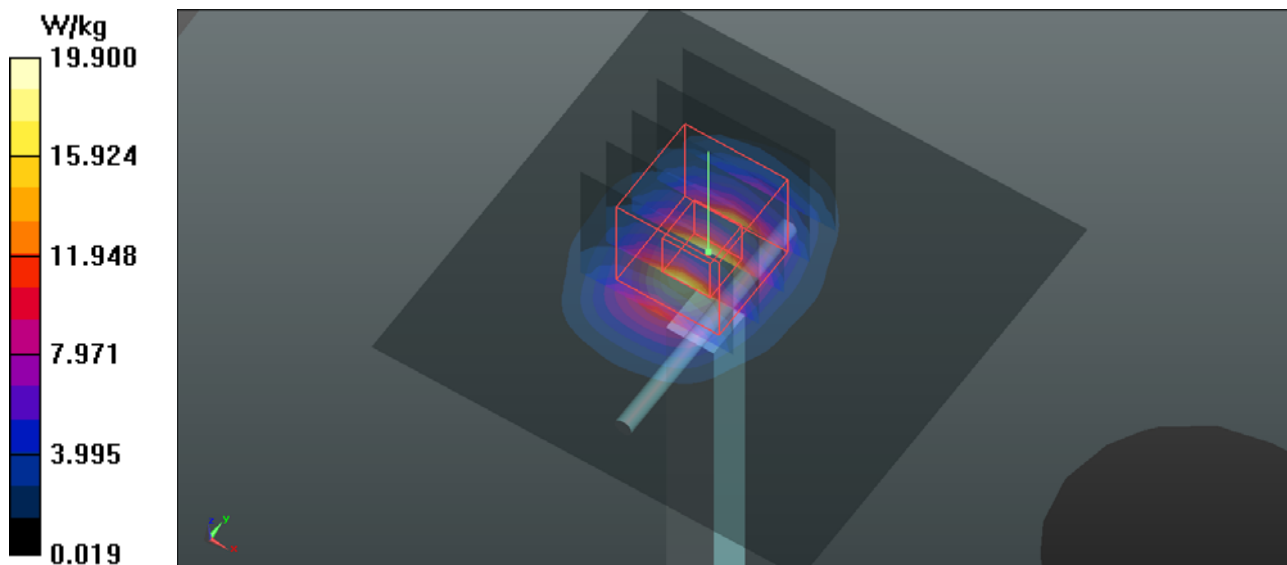

System Check_B835_121027

DUT: Dipole 835 MHz; Type: D835V2; SN: 4d139

Communication System: CW; Frequency: 835 MHz; Duty Cycle: 1:1

Medium: B835_1027 Medium parameters used: $f = 835 \text{ MHz}$; $\sigma = 0.962 \text{ mho/m}$; $\epsilon_r = 53.632$; $\rho = 1000 \text{ kg/m}^3$

Ambient Temperature : 21.9 °C ; Liquid Temperature : 20.8 °C

DASY5 Configuration:

- Probe: EX3DV4 - SN3873; ConvF(9.23, 9.23, 9.23); Calibrated: 2012/08/06;
- Sensor-Surface: 2mm (Mechanical Surface Detection)
- Electronics: DAE4 Sn1341; Calibrated: 2012/08/07
- Phantom: Front Phantom with CRP v5.0; Type: QD000P40CD; Serial: TP:1695
- Measurement SW: DASY52, Version 52.8 (3); SEMCAD X Version 14.6.7 (6848)

Pin=250mW/Area Scan (61x101x1): Measurement grid: dx=15mm, dy=15mm

Maximum value of SAR (interpolated) = 3.00 W/kg

Pin=250mW/Zoom Scan (5x5x7)/Cube 0: Measurement grid: dx=8mm, dy=8mm, dz=5mm

Reference Value = 57.262 V/m; Power Drift = 0.01 dB

Peak SAR (extrapolated) = 3.50 W/kg

SAR(1 g) = 2.43 W/kg; SAR(10 g) = 1.62 W/kg

Maximum value of SAR (measured) = 3.04 W/kg

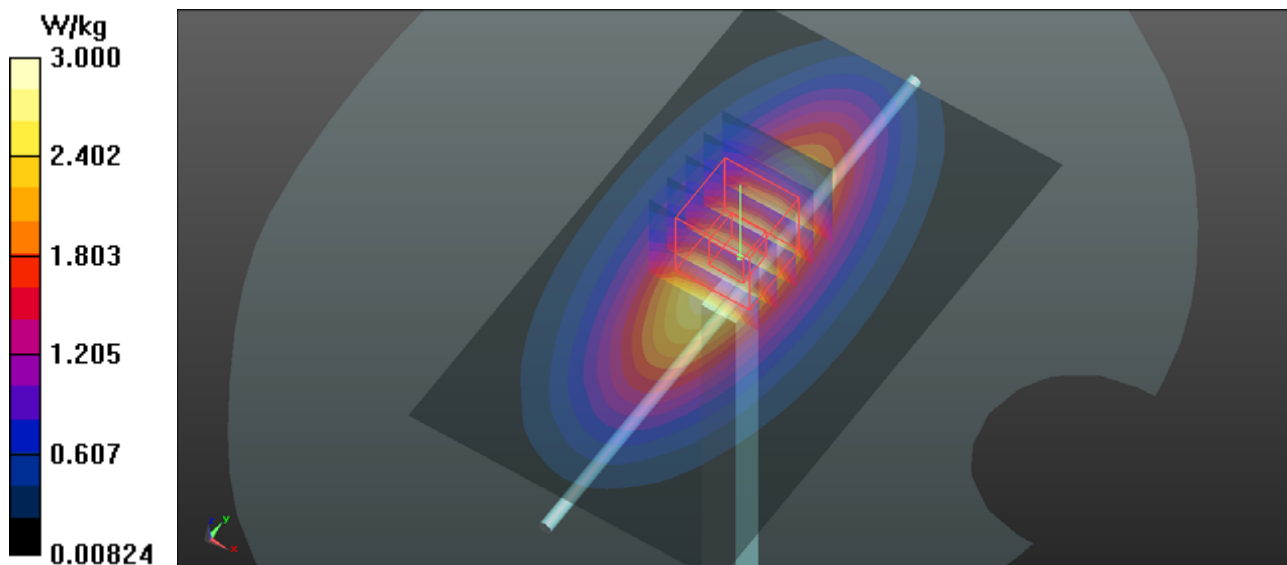

System Check_B835_121106

DUT: Dipole 835 MHz; Type: D835V2; SN: 4d139

Communication System: CW; Frequency: 835 MHz; Duty Cycle: 1:1

Medium: B835_1106 Medium parameters used: $f = 835 \text{ MHz}$; $\sigma = 1.011 \text{ mho/m}$; $\epsilon_r = 53.581$; $\rho = 1000 \text{ kg/m}^3$

Ambient Temperature : 22.1 °C ; Liquid Temperature : 21.1 °C

DASY5 Configuration:

- Probe: EX3DV4 - SN3873; ConvF(9.23, 9.23, 9.23); Calibrated: 2012/08/06;
- Sensor-Surface: 2mm (Mechanical Surface Detection)
- Electronics: DAE4 Sn1341; Calibrated: 2012/08/07
- Phantom: Front Phantom with CRP v5.0; Type: QD000P40CD; Serial: TP:1695
- Measurement SW: DASY52, Version 52.8 (3); SEMCAD X Version 14.6.7 (6848)

Pin=250mW/Area Scan (61x101x1): Measurement grid: dx=15mm, dy=15mm

Maximum value of SAR (interpolated) = 3.15 W/kg

Pin=250mW/Zoom Scan (5x5x7)/Cube 0: Measurement grid: dx=8mm, dy=8mm, dz=5mm

Reference Value = 57.262 V/m; Power Drift = 0.01 dB

Peak SAR (extrapolated) = 3.68 W/kg

SAR(1 g) = 2.56 W/kg; SAR(10 g) = 1.71 W/kg

Maximum value of SAR (measured) = 3.20 W/kg

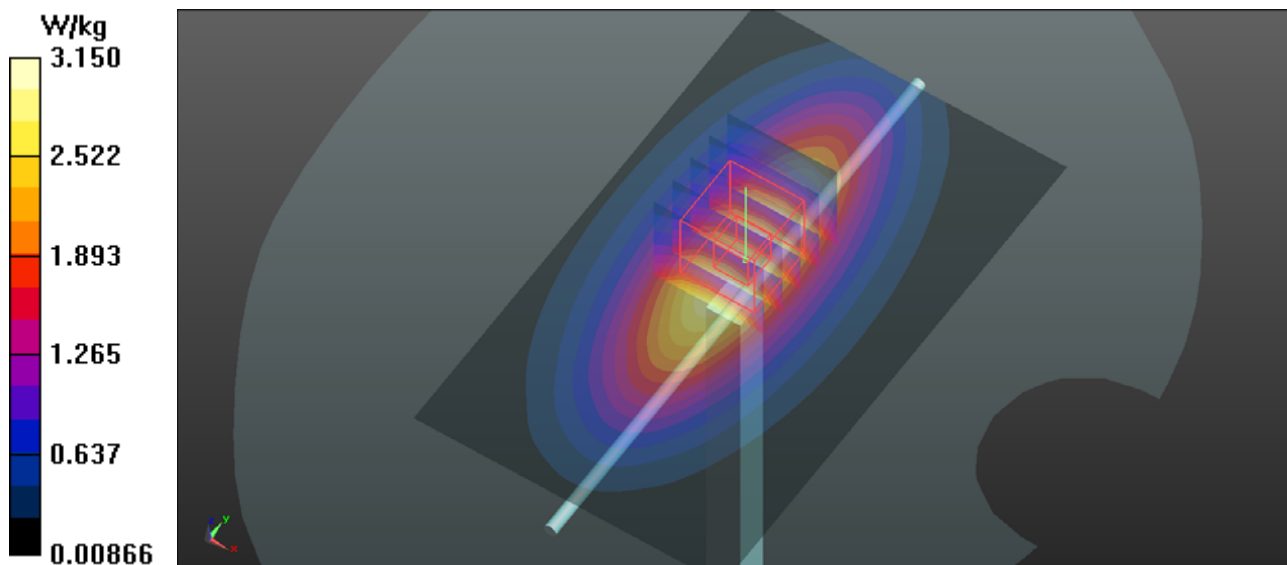

System Check_B1900_121026

DUT: Dipole: 1900MHz Type: D1900V2; SN:5d159

Communication System: CW; Frequency: 1900 MHz; Duty Cycle: 1:1

Medium: B1900_1026 Medium parameters used: $f = 1900$ MHz; $\sigma = 1.505$ mho/m; $\epsilon_r = 53.555$; $\rho = 1000$ kg/m³

Ambient Temperature : 21.6 °C; Liquid Temperature : 20.7 °C

DASY5 Configuration:

- Probe: EX3DV4 - SN3873; ConvF(7.33, 7.33, 7.33); Calibrated: 2012/08/06;
- Sensor-Surface: 2mm (Mechanical Surface Detection)
- Electronics: DAE4 Sn1341; Calibrated: 2012/08/07
- Phantom: Front Phantom with CRP v5.0; Type: QD000P40CD; Serial: TP:1695
- Measurement SW: DASY52, Version 52.8 (3); SEMCAD X Version 14.6.7 (6848)

Pin=250mW/Area Scan (61x61x1): Measurement grid: dx=15mm, dy=15mm

Maximum value of SAR (interpolated) = 14.3 W/kg

Pin=250mW/Zoom Scan (5x5x7)/Cube 0: Measurement grid: dx=8mm, dy=8mm, dz=5mm

Reference Value = 95.957 V/m; Power Drift = -0.01 dB

Peak SAR (extrapolated) = 17.4 W/kg

SAR(1 g) = 10.1 W/kg; SAR(10 g) = 5.35 W/kg

Maximum value of SAR (measured) = 14.1 W/kg

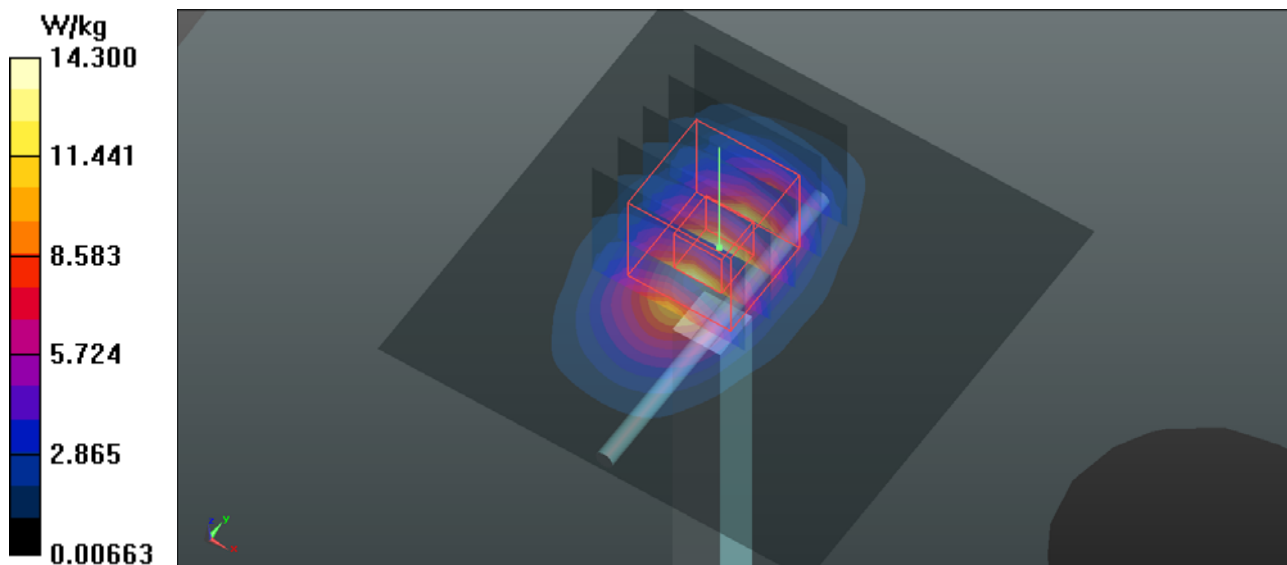

System Check_B2450_121026

DUT: Dipole 2450 MHz; Type:D2450V2; SN: 893

Communication System: CW; Frequency: 2450 MHz;Duty Cycle: 1:1

Medium: B2450_1026 Medium parameters used: $f = 2450$ MHz; $\sigma = 1.910$ mho/m; $\epsilon_r = 51.21$; $\rho = 1000$ kg/m³

Ambient Temperature : 21.8 °C ; Liquid Temperature : 20.8 °C

DASY5 Configuration:

- Probe: EX3DV4 - SN3873; ConvF(6.96, 6.96, 6.96); Calibrated: 2012/08/06;
- Sensor-Surface: 2mm (Mechanical Surface Detection)
- Electronics: DAE4 Sn1341; Calibrated: 2012/08/07
- Phantom: Right Phantom with CRP v5.0; Type: QD000P40CD; Serial: TP:1722
- Measurement SW: DASY52, Version 52.8 (3); SEMCAD X Version 14.6.7 (6848)

Pin=250mW/Area Scan (61x61x1): Measurement grid: dx=15mm, dy=15mm

Maximum value of SAR (interpolated) = 19.8 W/kg

Pin=250mW/Zoom Scan (5x5x7)/Cube 0: Measurement grid: dx=8mm, dy=8mm, dz=5mm

Reference Value = 102.2 V/m; Power Drift = 0.01 dB

Peak SAR (extrapolated) = 27.2 W/kg

SAR(1 g) = 12.9 W/kg; SAR(10 g) = 5.9 W/kg

Maximum value of SAR (measured) = 19.9 W/kg

