



# FCC Test Report

**APPLICANT** : Brightstar Corporation  
**EQUIPMENT** : 3G mobile phone  
**BRAND NAME** : Avvio, PULSARE, WUPA  
**MODEL NAME** : Avvio 750S, Avvio 750, PULSARE 750S,  
PULSARE 750, WUPA 750S, WUPA 750  
**FCC ID** : WVBA750X  
**STANDARD** : FCC 47 CFR FCC Part 15 Subpart B  
**CLASSIFICATION** : Certification

The product was received on Sep. 12, 2014 and testing was completed on Sep. 18, 2014. We, SPORTON INTERNATIONAL (KUNSHAN) INC., would like to declare that the tested sample has been evaluated in accordance with the test procedures given in ANSI C63.4-2003 and has been in compliance with the applicable technical standards.

The test results in this report apply exclusively to the tested model / sample. Without written approval of SPORTON INTERNATIONAL (KUNSHAN) INC., the test report shall not be reproduced except in full.

Reviewed by: Louis Wu / Manager

Approved by: Jones Tsai / Manager



Testing Laboratory  
2627

**SPORTON INTERNATIONAL (KUNSHAN) INC.**  
**No. 3-2, PingXiang Road, Kunshan, Jiangsu Province, P.R.C.**



## TABLE OF CONTENTS

REVISION HISTORY.....	3
SUMMARY OF TEST RESULT .....	4
<b>1. GENERAL DESCRIPTION .....</b>	<b>5</b>
1.1. Applicant.....	5
1.2. Manufacturer .....	5
1.3. Product Feature of Equipment Under Test .....	5
1.4. Product Specification subjective to this standard.....	6
1.5. Modification of EUT.....	7
1.6. Test Location.....	7
1.7. Applicable Standards .....	7
<b>2. TEST CONFIGURATION OF EQUIPMENT UNDER TEST.....</b>	<b>8</b>
2.1. Test Mode .....	8
2.2. Connection Diagram of Test System .....	10
2.3. Support Unit used in test configuration and system.....	11
2.4. EUT Operation Test Setup.....	12
<b>3. TEST RESULT.....</b>	<b>13</b>
3.1. Test of AC Conducted Emission Measurement .....	13
3.2. Test of Radiated Emission Measurement .....	19
<b>4. LIST OF MEASURING EQUIPMENT .....</b>	<b>25</b>
<b>5. UNCERTAINTY OF EVALUATION .....</b>	<b>26</b>
<b>APPENDIX A. SETUP PHOTOGRAPHS</b>	



## REVISION HISTORY

REPORT NO.	VERSION	DESCRIPTION	ISSUED DATE
FC491201	Rev. 01	Initial issue of report	Sep. 28, 2014



### SUMMARY OF TEST RESULT

Report Section	FCC Rule	Description	Limit	Result	Remark
3.1	15.107	AC Conducted Emission	< 15.107 limits	PASS	Under limit 5.96 dB at 0.330 MHz
3.2	15.109	Radiated Emission	< 15.109 limits	PASS	Under limit 10.53 dB at 34.850 MHz



# 1. General Description

## 1.1. Applicant

**Brightstar Corporation**

9725 NW 117th Ave., Miami, Florida, FL 33178, United States

## 1.2. Manufacturer

**Konka Telecommunications Techenology co., LTD.**

Overseas Chinese Town, Nanshan District, Shenzhen, China

## 1.3. Product Feature of Equipment Under Test

Product Feature	
<b>Equipment</b>	3G mobile phone
<b>Brand Name</b>	Avvio, PULSARE, WUPA
<b>Model Name</b>	Avvio 750S, Avvio 750, PULSARE 750S, PULSARE 750, WUPA 750S, WUPA 750
<b>FCC ID</b>	WVBA750X
<b>EUT supports Radios application</b>	GSM/GPRS/EGPRS(Downlink Only)/WCDMA/HSPA/HSPA+(Downlink Only) WLAN 2.4GHz 802.11b/g/n HT20/HT40 Bluetooth v3.0 + EDR/Bluetooth v4.0 LE
<b>HW Version</b>	I119 TMBRf
<b>SW Version</b>	KAAI119_En_0.01.818
<b>EUT Stage</b>	Production Unit

**Remark:**

1. The above EUT's information was declared by manufacturer. Please refer to the specifications or user's manual for more detailed description.
2. There are six types of EUT for this project. The differences between them are summary below:

Sample List	Model name	Brand name	SIM Slots
Sample 1	Avvio 750	Avvio	1
Sample 2	Avvio 750S	Avvio	2
Sample 3	PULSARE 750	PULSARE	1
Sample 4	PULSARE 750S	PULSARE	2
Sample 5	WUPA 750	WUPA	1
Sample 6	WUPA 750S	WUPA	2

These models are identical on hardware except the SIM slots. The different model with different brand is for market purpose.



### 1.4. Product Specification subjective to this standard

Product Specification subjective to this standard	
<b>Tx Frequency</b>	GSM850 : 824.2 MHz ~ 848.8 MHz GSM1900 : 1850.2 MHz ~ 1909.8MHz WCDMA Band V : 826.4 MHz ~ 846.6 MHz WCDMA Band II : 1852.4 MHz ~ 1907.6 MHz 802.11b/g/n: 2412 MHz ~ 2462 MHz Bluetooth: 2402 MHz ~ 2480 MHz
<b>Rx Frequency</b>	GSM850 : 869.2 MHz ~ 893.8 MHz GSM1900 : 1930.2 MHz ~ 1989.8 MHz WCDMA Band V : 871.4 MHz ~ 891.6 MHz WCDMA Band II : 1932.4 MHz ~ 1987.6 MHz 802.11b/g/n: 2412 MHz ~ 2462 MHz Bluetooth: 2402 MHz ~ 2480 MHz GPS : 1.57542 GHz
<b>Antenna Type</b>	WWAN : Fixed Internal Antenna WLAN : PIFA Antenna Bluetooth : PIFA Antenna GPS: PIFA Antenna
<b>Type of Modulation</b>	GSM: GMSK GPRS: GMSK EDGE(MCS 0-4): GMSK /(MCS 5-9): 8PSK(Downlink Only) WCDMA: QPSK (Uplink) HSDPA: QPSK (Uplink) HSUPA: QPSK (Uplink) HSPA+: 16QAM (Downlink Only) 802.11b : DSSS (DBPSK / DQPSK / CCK) 802.11g/n : OFDM (BPSK / QPSK / 16QAM / 64QAM) Bluetooth v4.0 LE : GFSK Bluetooth (1Mbps) : GFSK Bluetooth (2Mbps) : $\pi/4$ -DQPSK Bluetooth (3Mbps) : 8-DPSK GPS : BPSK



### 1.5. Modification of EUT

No modifications are made to the EUT during all test items.

### 1.6. Test Location

<b>Test Site</b>	SPORTON INTERNATIONAL (KUNSHAN) INC.		
<b>Test Site Location</b>	No. 3-2, PingXiang Road, Kunshan, Jiangsu Province, P.R.C. TEL: +86-0512-5790-0158 FAX: +86-0512-5790-0958		
<b>Test Site No.</b>	<b>Sporton Site No.</b>		<b>FCC Registration No.</b>
	CO01-KS	03CH01-KS	149928

### 1.7. Applicable Standards

According to the specifications of the manufacturer, the EUT must comply with the requirements of the following standards:

- ♦ FCC 47 CFR FCC Part 15 Subpart B
- ♦ ANSI C63.4-2003

**Remark:** All test items were verified and recorded according to the standards and without any deviation during the test.



## 2. Test Configuration of Equipment Under Test

### 2.1. Test Mode

The EUT has been associated with peripherals pursuant to ANSI C63.4-2003 and configuration operated in a manner tended to maximize its emission characteristics in a typical application.

Frequency range investigated: conduction (150 kHz to 30 MHz), radiation (30MHz to the 5th harmonic of the highest fundamental frequency or to 40 GHz, whichever is lower).

The following tables are showing the test modes as the worst cases and recorded in this report.

Item	EUT Configuration	Test Condition		
		EMI AC	EMI RE<1G	EMI RE≥1G
1.	Charging Mode (EUT with adapter)	☒	☒	☒
2.	Data application transferred mode (EUT connected with notebook)	☒	☒	☒

**Abbreviations:**

- EMI AC: AC conducted emissions
- EMI RE ≥ 1G: EUT radiated emissions ≥ 1GHz
- EMI RE < 1G: EUT radiated emissions < 1GHz





Test Items	EUT Configure Mode	Function Type
AC Conducted Emission	1/2	<p>Mode 1: GSM850 Idle + Bluetooth Idle + WLAN Idle + USB Cable (Charging from Adapter) + Earphone + Camera + SIM1&lt;Fig.1&gt;</p> <p>Mode 2: GSM1900 Idle + Bluetooth Idle + WLAN Idle + USB Cable (Charging from Adapter) + Earphone + MPEG4 + SIM2&lt;Fig.1&gt;</p> <p>Mode 3: WCDMA Band V Idle + Bluetooth Idle + WLAN Idle + USB Cable (Data Link with Notebook) + Earphone + GPS Rx + SIM1&lt;Fig.2&gt;</p>
Radiated Emissions < 1GHz	1/2	<p>Mode 1: GSM850 Idle + Bluetooth Idle + WLAN Idle + USB Cable (Charging from Adapter) + Earphone + Camera + SIM1&lt;Fig.1&gt;</p> <p>Mode 2: GSM1900 Idle + Bluetooth Idle + WLAN Idle + USB Cable (Charging from Adapter) + Earphone + MPEG4 + SIM2&lt;Fig.1&gt;</p> <p>Mode 3: WCDMA Band V Idle + Bluetooth Idle + WLAN Idle + USB Cable (Data Link with Notebook) + Earphone + GPS Rx + SIM1&lt;Fig.2&gt;</p>
Radiated Emissions ≥ 1GHz	1/2	<p>Mode 1: GSM1900 Idle + Bluetooth Idle + WLAN Idle + USB Cable (Charging from Adapter) + Earphone + MPEG4 + SIM2&lt;Fig.1&gt;</p> <p>Mode 2: WCDMA Band V Idle + Bluetooth Idle + WLAN Idle + USB Cable (Data Link with Notebook) + Earphone + GPS Rx + SIM1&lt;Fig.2&gt;</p>
<p><b>Remark:</b></p> <ol style="list-style-type: none"> <li>The worst case of AC is mode 2; and the USB Link mode of AC is mode 3, only the test data of these modes are reported.</li> <li>The worst case of RE &lt; 1G is mode 2; and the USB Link mode of RE is mode 3, only the test data of these modes are reported.</li> <li>Link with Notebook means data application transferred mode between EUT and Notebook</li> </ol>		

## 2.2. Connection Diagram of Test System

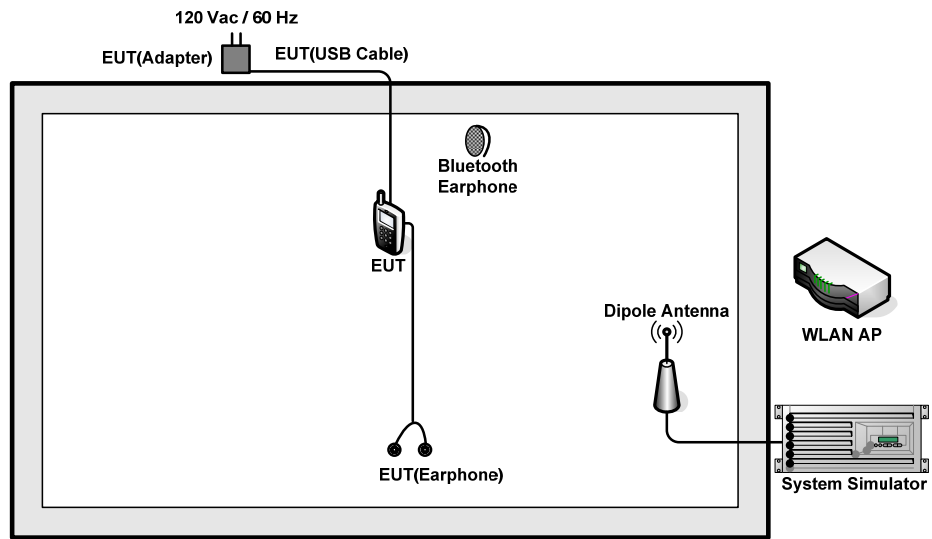

<Fig.1>

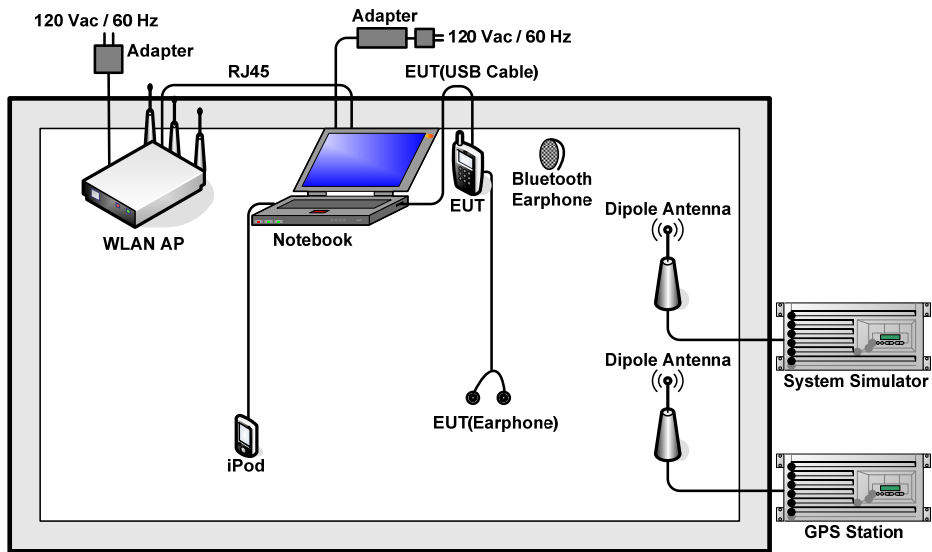

<Fig.2>

### 2.3. Support Unit used in test configuration and system

Item	Equipment	Trade Name	Model Name	FCC ID	Data Cable	Power Cord
1.	System Simulator	R&S	CMU 200	N/A	N/A	Unshielded, 1.8 m
2.	GPS Station	ADIVIC	MP9000	N/A	N/A	Unshielded, 1.8 m
3.	WLAN AP	D-Link	DIR-855	KA2DIR855A2	N/A	Unshielded, 1.8 m
4.	Bluetooth Earphone	Lenovo	LBH505	N/A	N/A	N/A
5.	Bluetooth Earphone	Nokia	BH-102	PYAHS-107W	N/A	N/A
6.	Notebook	Lenovo	G480	N/A	N/A	AC I/P: Unshielded, 1.2 m DC O/P: Shielded, 1.8 m
7.	iPod	Apple	A1199	FCC DoC	Unshielded, 1.2 m	N/A



## **2.4. EUT Operation Test Setup**

The EUT was in GSM or WCDMA idle mode during the testing. The EUT was synchronized to the BCCH, and was in continuous receiving mode by setting system simulator's paging reorganization.

At the same time, the EUT was attached to the Bluetooth earphone or WLAN AP, and the following programs installed in the EUT were programmed during the test.

1. Data application is transferred between notebook and EUT via USB cable.
2. Turn on GPS function to make the EUT receive continuous signals from GPS station.
3. Execute "Video Player" to play MPEG4 files.
4. Turn on camera to capture images.

### 3. Test Result

#### 3.1. Test of AC Conducted Emission Measurement

##### 3.1.1 Limits of AC Conducted Emission

For equipment that is designed to be connected to the public utility (AC) power line, the radio frequency voltage that is conducted back onto the AC power line on any frequency or frequencies within the band 150 kHz to 30 MHz shall not exceed the limits in the following table.

Frequency of emission (MHz)	Conducted limit (dBuV)	
	Quasi-peak	Average
0.15-0.5	66 to 56*	56 to 46*
0.5-5	56	46
5-30	60	50

\*Decreases with the logarithm of the frequency.

##### 3.1.2 Measuring Instruments

The measuring equipment is listed in the section 4 of this test report.

##### 3.1.3 Test Procedure

1. The EUT was placed 0.4 meter from the conducting wall of the shielding room was kept at least 80 centimeters from any other grounded conducting surface.
2. Connect EUT to the power mains through a line impedance stabilization network (LISN).
3. All the support units are connecting to the other LISN.
4. The LISN provides 50 ohm coupling impedance for the measuring instrument.
5. The FCC states that a 50 ohm, 50 microhenry LISN should be used.
6. Both sides of AC line were checked for maximum conducted interference.
7. The frequency range from 150 kHz to 30 MHz was searched.
8. Set the test-receiver system to Peak Detect Function and specified bandwidth (IF Bandwidth = 9kHz) with Maximum Hold Mode. Then measurement is also conducted by Average Detector and Quasi-Peak Detector Function respectively.

### 3.1.4 Test Setup





3.1.5 Test Result of AC Conducted Emission

Test Mode :	Mode 2	Temperature :	22~24°C
Test Engineer :	Eligah Wang	Relative Humidity :	55~58%
Test Voltage :	120Vac / 60Hz	Phase :	Line
Function Type :	GSM1900 Idle + Bluetooth Idle + WLAN Idle + USB Cable (Charging from Adapter) + Earphone + MPEG4 + SIM2		

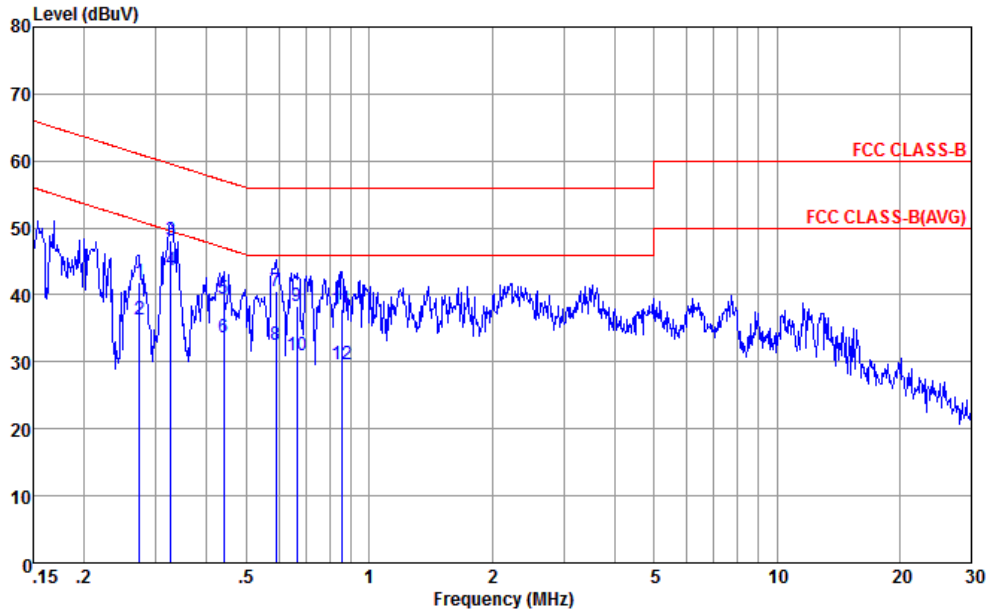

Site : CO01-KS  
 Condition : FCC CLASS-B LISN-L20140306 LINE  
 Project : (FC) 491201  
 mode : Mode 2

	Freq	Level	Over	Limit	Read	LISN	Cable	Remark
	MHz	dBuV	Limit	Line	Level	Factor	Loss	
		dBuV	dB	dBuV	dBuV	dB	dB	
1	0.27	41.86	-19.17	61.03	30.61	0.80	10.45	QP
2	0.27	36.36	-14.67	51.03	25.11	0.80	10.45	Average
3	0.33	48.17	-11.36	59.53	37.29	0.53	10.35	QP
4	0.33	43.57	-5.96	49.53	32.69	0.53	10.35	Average
5	0.44	39.43	-17.64	57.07	28.90	0.26	10.27	QP
6	0.44	33.63	-13.44	47.07	23.10	0.26	10.27	Average
7	0.59	40.54	-15.46	56.00	30.10	0.20	10.24	QP
8	0.59	32.54	-13.46	46.00	22.10	0.20	10.24	Average
9	0.66	38.22	-17.78	56.00	27.80	0.20	10.22	QP
10	0.66	31.02	-14.98	46.00	20.60	0.20	10.22	Average
11	0.86	37.83	-18.17	56.00	27.50	0.14	10.19	QP
12	0.86	29.73	-16.27	46.00	19.40	0.14	10.19	Average



Test Mode :	Mode 2	Temperature :	22~24°C
Test Engineer :	Eligah Wang	Relative Humidity :	55~58%
Test Voltage :	120Vac / 60Hz	Phase :	Neutral
Function Type :	GSM1900 Idle + Bluetooth Idle + WLAN Idle + USB Cable (Charging from Adapter) + Earphone + MPEG4 + SIM2		

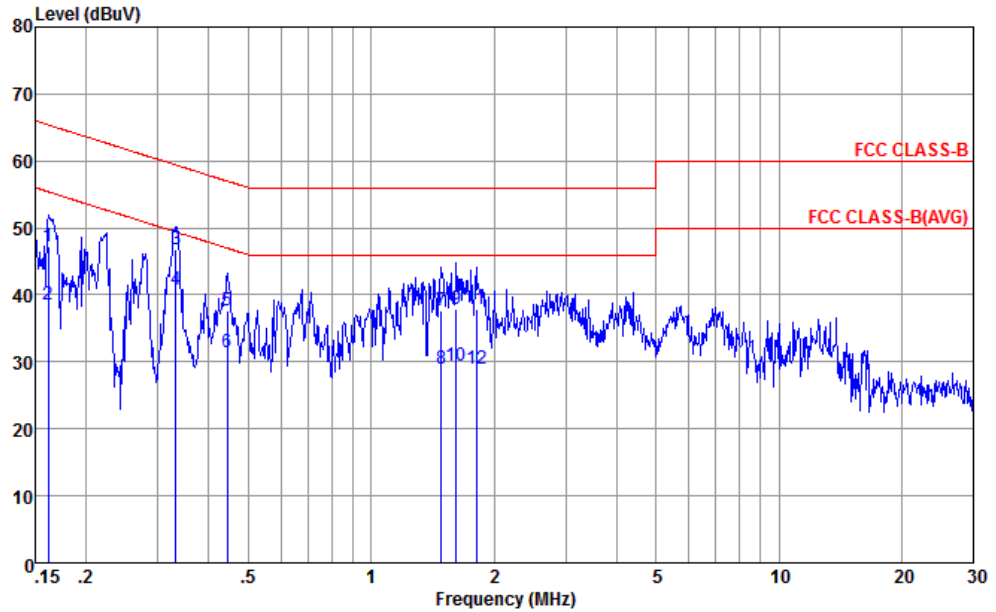

Site : CO01-KS  
 Condition : FCC CLASS-B LISN-N20140306 NEUTRAL  
 Project : (FC) 491201  
 mode : Mode 2

	Freq	Level	Over Limit	Limit Line	Read Level	LISN Factor	Cable Loss	Remark
	MHz	dBuV	dB	dBuV	dBuV	dB	dB	
1	0.16	47.28	-18.10	65.38	34.90	1.71	10.67	QP
2	0.16	38.48	-16.90	55.38	26.10	1.71	10.67	Average
3	0.33	46.80	-12.60	59.40	35.89	0.57	10.34	QP
4	0.33	40.80	-8.60	49.40	29.89	0.57	10.34	Average
5	0.44	37.72	-19.26	56.98	27.10	0.35	10.27	QP
6	0.44	31.42	-15.56	46.98	20.80	0.35	10.27	Average
7	1.49	37.69	-18.41	56.00	27.30	0.10	10.19	QP
8	1.49	28.99	-17.01	46.00	18.70	0.10	10.19	Average
9	1.62	37.89	-18.11	56.00	27.60	0.10	10.19	QP
10	1.62	29.49	-16.51	46.00	19.20	0.10	10.19	Average
11	1.81	37.79	-18.21	56.00	27.50	0.10	10.19	QP
12	1.81	28.99	-17.01	46.00	18.70	0.10	10.19	Average





Test Mode :	Mode 3	Temperature :	22~24°C
Test Engineer :	Eligah Wang	Relative Humidity :	55~58%
Test Voltage :	120Vac / 60Hz	Phase :	Line
Function Type :	WCDMA Band V Idle + Bluetooth Idle + WLAN Idle + USB Cable (Data Link with Notebook) + Earphone + GPS Rx + SIM1		

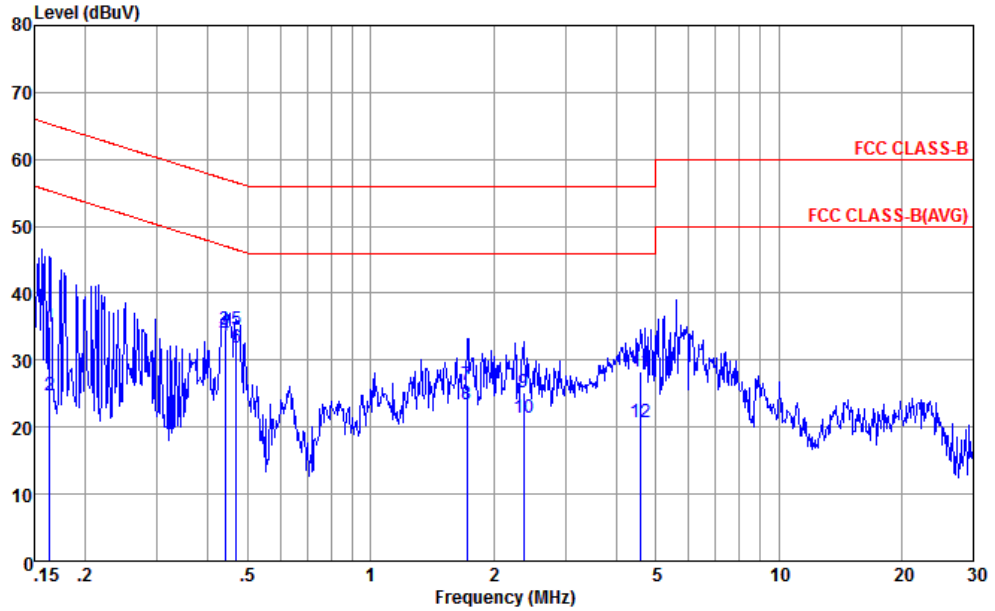

Site : CO01-KS  
 Condition : FCC CLASS-B LISN-L20140306 LINE  
 Project : (FC) 491201  
 mode : Mode 3

	Freq	Level	Over Limit	Limit Line	Read Level	LISN Factor	Cable Loss	Remark
	MHz	dBuV	dB	dBuV	dBuV	dB	dB	
1	0.16	34.98	-30.32	65.30	22.60	1.72	10.66	QP
2	0.16	24.68	-30.62	55.30	12.30	1.72	10.66	Average
3	0.44	34.63	-22.44	57.07	24.10	0.26	10.27	QP
4	0.44	33.63	-13.44	47.07	23.10	0.26	10.27	Average
5	0.47	34.60	-21.94	56.54	24.10	0.23	10.27	QP
6	0.47	31.90	-14.64	46.54	21.40	0.23	10.27	Average
7	1.73	26.39	-29.61	56.00	16.10	0.10	10.19	QP
8	1.73	23.39	-22.61	46.00	13.10	0.10	10.19	Average
9	2.37	25.21	-30.79	56.00	14.90	0.11	10.20	QP
10	2.37	21.41	-24.59	46.00	11.10	0.11	10.20	Average
11	4.60	28.35	-27.65	56.00	17.90	0.20	10.25	QP
12	4.60	20.75	-25.25	46.00	10.30	0.20	10.25	Average



Test Mode :	Mode 3	Temperature :	22~24°C
Test Engineer :	Eligah Wang	Relative Humidity :	55~58%
Test Voltage :	120Vac / 60Hz	Phase :	Neutral
Function Type :	WCDMA Band V Idle + Bluetooth Idle + WLAN Idle + USB Cable (Data Link with Notebook) + Earphone + GPS Rx + SIM1		

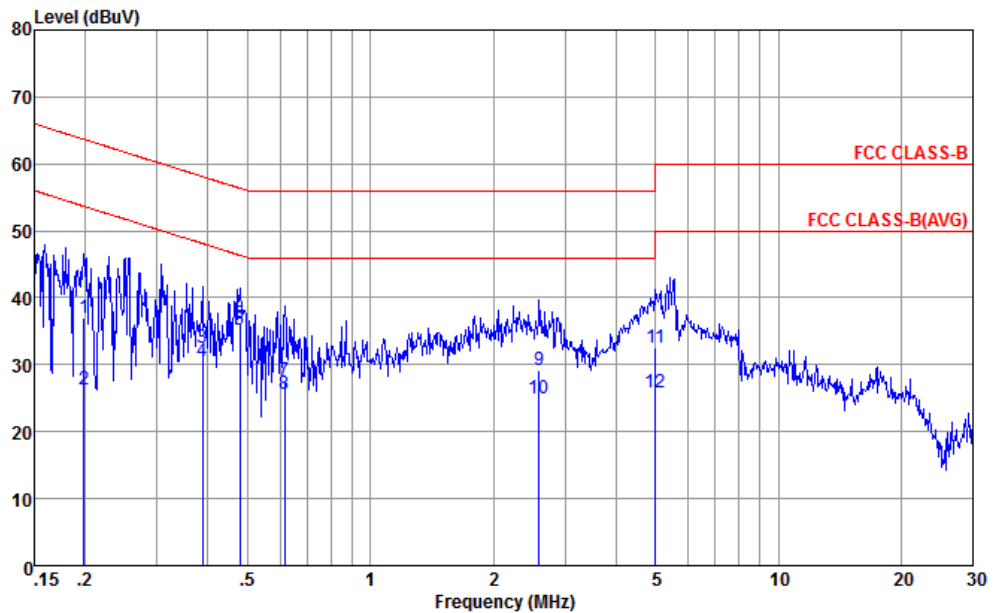

Site : CO01-KS  
 Condition : FCC CLASS-B LISN-N20140306 NEUTRAL  
 Project : (FC) 491201  
 mode : Mode 3

	Freq	Level	Over	Limit	Read	LISN	Cable	Remark
	MHz	dBuV	Limit	Line	Level	Factor	Loss	
			dB	dBuV	dBuV	dB	dB	
1	0.20	36.89	-26.78	63.67	25.30	1.01	10.58	QP
2	0.20	26.39	-27.28	53.67	14.80	1.01	10.58	Average
3	0.39	32.51	-25.61	58.12	21.80	0.42	10.29	QP
4	0.39	30.61	-17.51	48.12	19.90	0.42	10.29	Average
5	0.48	36.18	-20.18	56.36	25.59	0.32	10.27	QP
6	0.48	35.18	-11.18	46.36	24.59	0.32	10.27	Average
7	0.62	27.67	-28.33	56.00	17.20	0.23	10.24	QP
8	0.62	25.57	-20.43	46.00	15.10	0.23	10.24	Average
9	2.59	29.22	-26.78	56.00	18.89	0.12	10.21	QP
10	2.59	24.92	-21.08	46.00	14.59	0.12	10.21	Average
11	5.00	32.46	-27.54	60.00	22.00	0.20	10.26	QP
12	5.00	25.96	-24.04	50.00	15.50	0.20	10.26	Average



### 3.2. Test of Radiated Emission Measurement

#### 3.2.1. Limit of Radiated Emission

The emissions from an unintentional radiator shall not exceed the field strength levels specified in the following table:

Frequency (MHz)	Field Strength (microvolts/meter)	Measurement Distance (meters)
30 – 88	100	3
88 – 216	150	3
216 - 960	200	3
Above 960	500	3

#### 3.2.2. Measuring Instruments

The measuring equipment is listed in the section 4 of this test report.

#### 3.2.3. Test Procedures

1. The EUT was placed on a turntable with 0.8 meter above ground.
2. The EUT was set 3 meters from the interference receiving antenna, which was mounted on the top of a variable height antenna tower.
3. The table was rotated 360 degrees to determine the position of the highest radiation.
4. The antenna height is adjusted between one to four meters above ground to find the maximum value of the field strength for both horizontal polarization and vertical polarization of the antenna.
5. For each suspected emission, the EUT was arranged to its worst case and then tune the antenna tower (from 1 m to 4 m) and turntable (from 0 degree to 360 degrees) to find the maximum reading.
6. Set the test-receiver system to Peak Detect Function and specified bandwidth with Maximum Hold Mode (RBW=120kHz/VBW=300kHz for frequency below 1GHz; RBW=1MHz VBW=3MHz (Peak), RBW=1MHz/VBW=10Hz (Average) for frequency above 1GHz).
7. If the emission level of the EUT in peak mode was 3 dB lower than the limit specified, peak values of EUT will be reported. Otherwise, the emission will be repeated by using the quasi-peak method and reported.
8. Emission level (dBµV/m) = 20 log Emission level (µV/m)
9. Corrected Reading: Antenna Factor + Cable Loss + Read Level - Preamp Factor = Level

### 3.2.4. Test Setup of Radiated Emission

For radiated emissions from 30MHz to 1GHz

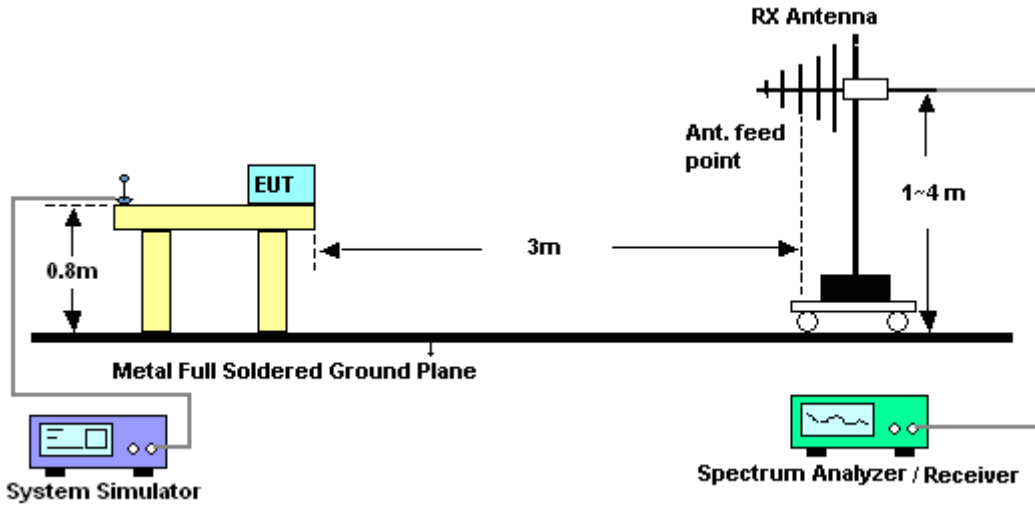

For radiated emissions above 1GHz

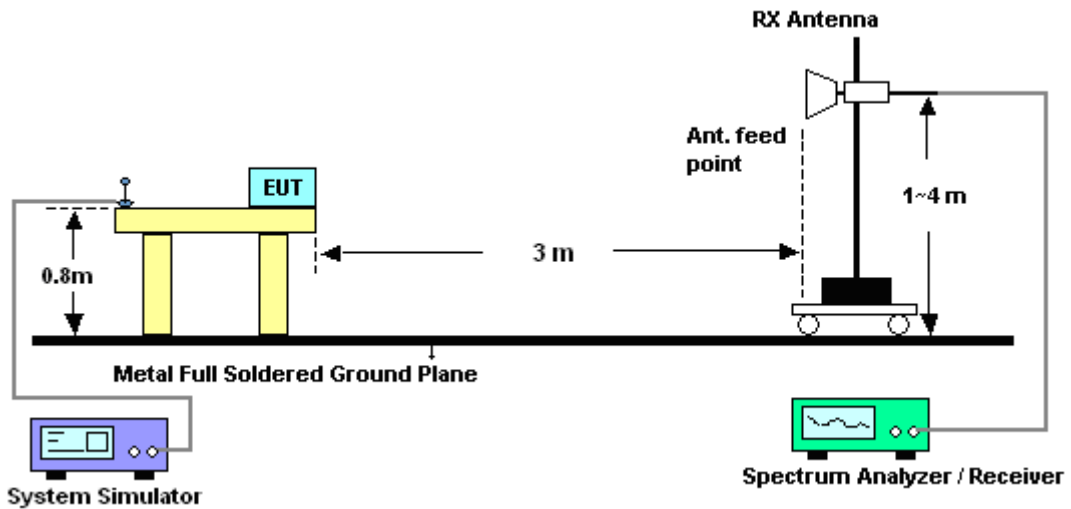



3.2.5. Test Result of Radiated Emission

Test Mode :	Mode 2	Temperature :	22~23°C
Test Engineer :	Star Wei	Relative Humidity :	42~43%
Test Distance :	3m	Polarization :	Horizontal
Function Type :	GSM1900 Idle + Bluetooth Idle + WLAN Idle + USB Cable (Charging from Adapter) + Earphone + MPEG4 + SIM2		

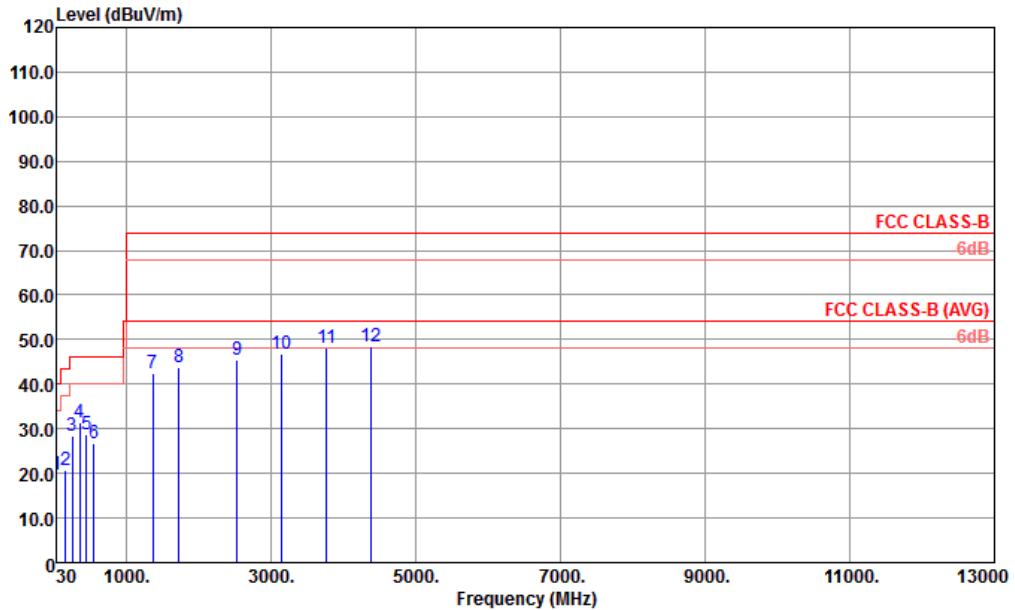

Site : 03CH01-KS  
 Condition : FCC CLASS-B 3m LF\_ANT\_23182 HORIZONTAL  
 Project : (FC) 491201  
 Mode : 2

	Freq	Level	Over	Limit	ReadAntenna	Cable	Preamp	A/Pos	T/Pos	Remark	
	MHz	dBuV/m	dB	dBuV/m	dBuV	dB/m	dB	dB	cm	deg	
1	30.97	19.82	-20.18	40.00	35.62	17.29	0.49	33.58	---	---	Peak
2	163.86	20.59	-22.91	43.50	43.56	9.44	1.17	33.58	---	---	Peak
3	249.22	28.51	-17.49	46.00	48.54	11.96	1.45	33.44	---	---	Peak
4	350.10	31.50	-14.50	46.00	48.66	14.50	1.70	33.36	200	147	Peak
5	450.01	28.63	-17.37	46.00	43.59	16.30	1.95	33.21	---	---	Peak
6	549.92	26.78	-19.22	46.00	39.20	18.50	2.09	33.01	---	---	Peak
7	1364.00	42.52	-31.48	74.00	43.41	29.66	2.74	33.29	---	---	Peak
8	1726.00	43.79	-30.21	74.00	42.29	31.54	3.06	33.10	---	---	Peak
9	2532.00	45.29	-28.71	74.00	41.81	33.12	3.68	33.32	---	---	Peak
10	3150.00	46.72	-27.28	74.00	42.36	33.83	4.16	33.63	---	---	Peak
11	3766.00	48.25	-25.75	74.00	42.55	34.78	4.57	33.65	---	---	Peak
12	4388.00	48.47	-25.53	74.00	42.22	35.07	4.94	33.76	---	---	Peak



Test Mode :	Mode 2	Temperature :	22~23°C
Test Engineer :	Star Wei	Relative Humidity :	42~43%
Test Distance :	3m	Polarization :	Vertical
Function Type :	GSM1900 Idle + Bluetooth Idle + WLAN Idle + USB Cable (Charging from Adapter) + Earphone + MPEG4 + SIM2		

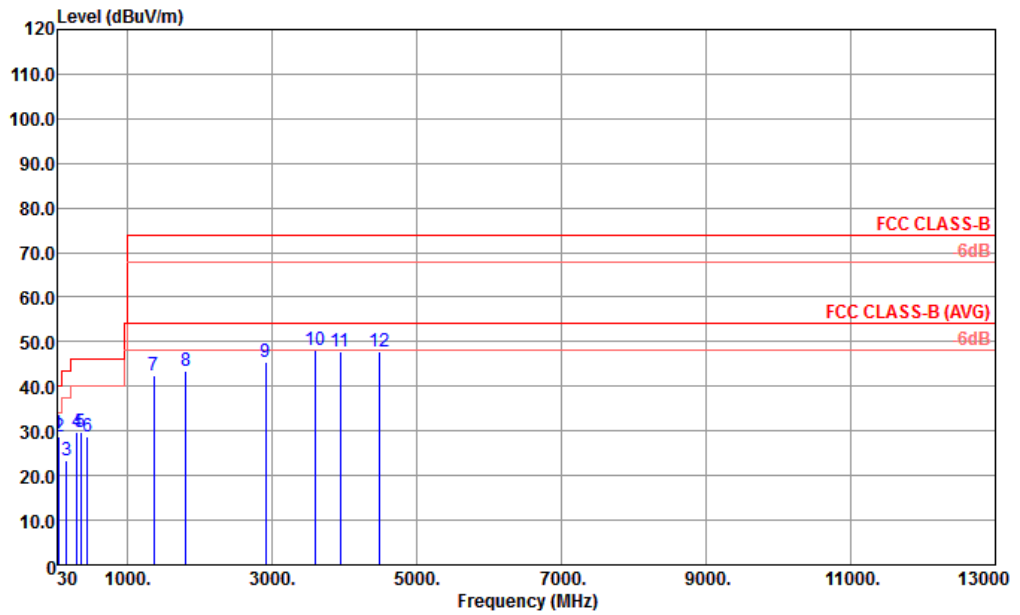

Site : 03CH01-KS  
 Condition : FCC CLASS-B 3m LF\_ANT\_23182 VERTICAL  
 Project : (FC) 491201  
 Mode : 2

	Freq	Level	Over	Limit	ReadAntenna	Cable	Preamp	A/Pos	T/Pos	Remark	
	MHz	dBuV/m	dB	dBuV/m	dBuV	dB/m	dB	dB	cm	deg	
1	34.85	29.47	-10.53	40.00	47.44	15.10	0.54	33.61	100	147	Peak
2	51.34	28.64	-11.36	40.00	54.35	7.21	0.66	33.58	---	---	Peak
3	160.95	23.51	-19.99	43.50	46.37	9.56	1.16	33.58	---	---	Peak
4	299.66	29.66	-16.34	46.00	48.44	13.00	1.60	33.38	---	---	Peak
5	350.10	29.67	-16.33	46.00	46.83	14.50	1.70	33.36	---	---	Peak
6	450.01	28.85	-17.15	46.00	43.81	16.30	1.95	33.21	---	---	Peak
7	1364.00	42.38	-31.62	74.00	43.27	29.66	2.74	33.29	---	---	Peak
8	1804.00	43.46	-30.54	74.00	41.64	31.79	3.13	33.10	---	---	Peak
9	2916.00	45.54	-28.46	74.00	41.47	33.63	4.00	33.56	---	---	Peak
10	3606.00	48.24	-25.76	74.00	42.87	34.54	4.51	33.68	---	---	Peak
11	3938.00	47.95	-26.05	74.00	41.97	34.95	4.64	33.61	---	---	Peak
12	4484.00	47.84	-26.16	74.00	41.54	35.09	5.00	33.79	---	---	Peak



Test Mode :	Mode 3	Temperature :	22~23°C
Test Engineer :	Star Wei	Relative Humidity :	42~43%
Test Distance :	3m	Polarization :	Horizontal
Function Type :	WCDMA Band V Idle + Bluetooth Idle + WLAN Idle + USB Cable (Data Link with Notebook) + Earphone + GPS Rx + SIM1		
Remark :	#7 is system simulator signal which can be ignored.		

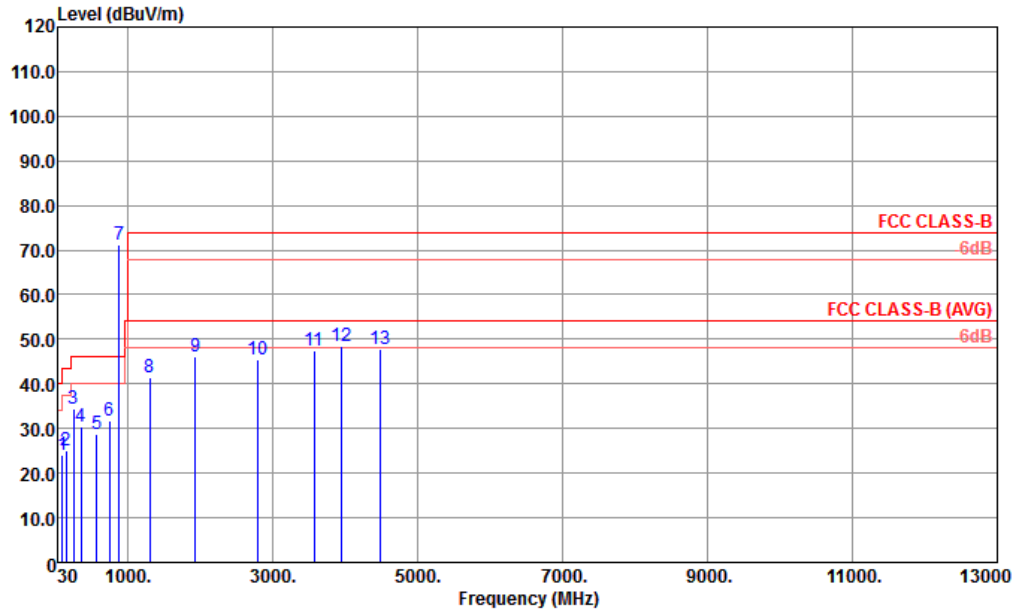

Site : 03CH01-KS  
 Condition : FCC CLASS-B 3m LF\_ANT\_23182 HORIZONTAL  
 Project : (FC) 491201  
 Mode : 3

	Freq	Level	Over Limit	Limit Line	ReadAntenna	Cable	Preamp	A/Pos	T/Pos	Remark	
	MHz	dBuV/m	dB	dBuV/m	dBuV	dB/m	dB	dB	cm	deg	
1	95.96	23.93	-19.57	43.50	46.74	9.91	0.90	33.62	---	---	Peak
2	149.31	25.19	-18.31	43.50	47.69	10.07	1.11	33.58	---	---	Peak
3	249.22	34.58	-11.42	46.00	54.61	11.96	1.45	33.44	100	145	Peak
4	350.10	30.58	-15.42	46.00	47.74	14.50	1.70	33.36	---	---	Peak
5	574.17	28.72	-17.28	46.00	40.96	18.55	2.19	32.98	---	---	Peak
6	749.74	31.71	-14.29	46.00	42.13	19.90	2.46	32.78	---	---	Peak
7 *	881.66	71.11			80.48	20.47	2.68	32.52	---	---	Peak
8	1304.00	41.29	-32.71	74.00	42.52	29.45	2.69	33.37	---	---	Peak
9	1932.00	46.22	-27.78	74.00	43.86	32.21	3.25	33.10	---	---	Peak
10	2798.00	45.49	-28.51	74.00	41.57	33.51	3.90	33.49	---	---	Peak
11	3576.00	47.55	-26.45	74.00	42.23	34.51	4.50	33.69	---	---	Peak
12	3942.00	48.36	-25.64	74.00	42.38	34.95	4.64	33.61	---	---	Peak
13	4492.00	47.86	-26.14	74.00	41.56	35.09	5.00	33.79	---	---	Peak



Test Mode :	Mode 3	Temperature :	22~23°C
Test Engineer :	Star Wei	Relative Humidity :	42~43%
Test Distance :	3m	Polarization :	Vertical
Function Type :	WCDMA Band V Idle + Bluetooth Idle + WLAN Idle + USB Cable (Data Link with Notebook) + Earphone + GPS Rx + SIM1		
Remark :	#7 is system simulator signal which can be ignored.		

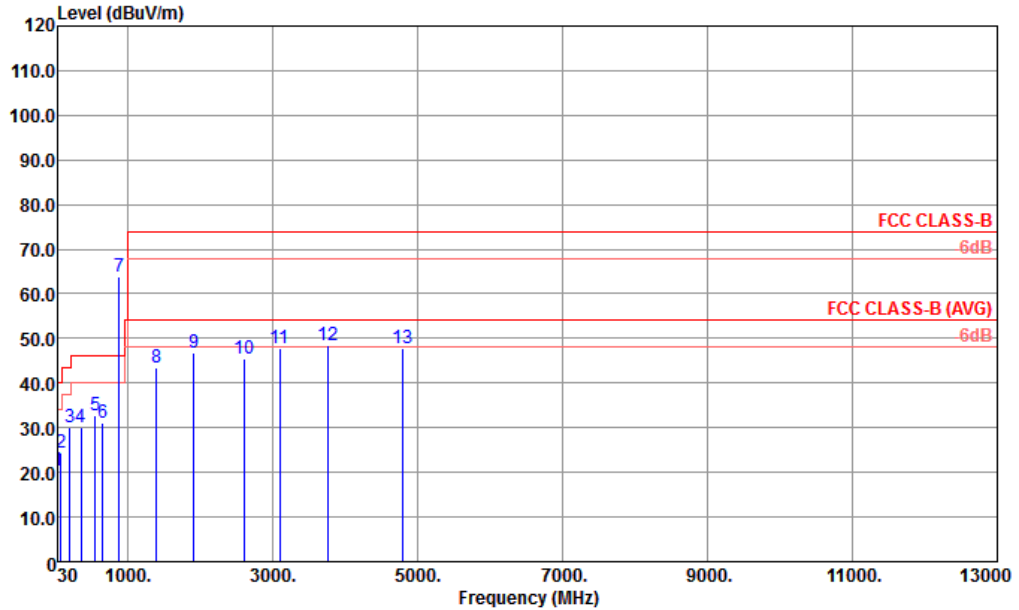

Site : 03CH01-KS  
 Condition : FCC CLASS-B 3m LF\_ANT\_23182 VERTICAL  
 Project : (FC) 491201  
 Mode : 3

	Freq	Level	Over Limit	Limit Line	ReadAntenna	Cable	Preamp	A/Pos	T/Pos	Remark	
	MHz	dBuV/m	dB	dBuV/m	dBuV	dB/m	dB	dB	cm	deg	
1	33.88	20.45	-19.55	40.00	37.96	15.56	0.53	33.60	---	---	Peak
2	72.68	24.47	-15.53	40.00	51.72	5.55	0.79	33.59	---	---	Peak
3	196.84	30.18	-13.32	43.50	53.59	8.86	1.29	33.56	---	---	Peak
4	350.10	30.08	-15.92	46.00	47.24	14.50	1.70	33.36	---	---	Peak
5	549.92	32.83	-13.17	46.00	45.25	18.50	2.09	33.01	100	200	Peak
6	649.83	31.20	-14.80	46.00	42.95	18.90	2.30	32.95	---	---	Peak
7 *	881.66	63.74			73.11	20.47	2.68	32.52	---	---	Peak
8	1400.00	43.37	-30.63	74.00	43.91	29.89	2.78	33.21	---	---	Peak
9	1916.00	46.66	-27.34	74.00	44.35	32.17	3.24	33.10	---	---	Peak
10	2610.00	45.48	-28.52	74.00	41.84	33.26	3.74	33.36	---	---	Peak
11	3098.00	47.65	-26.35	74.00	43.37	33.78	4.11	33.61	---	---	Peak
12	3766.00	48.50	-25.50	74.00	42.80	34.78	4.57	33.65	---	---	Peak
13	4792.00	47.64	-26.36	74.00	41.05	35.17	5.22	33.80	---	---	Peak





## 4. List of Measuring Equipment

Instrument	Manufacturer	Model No.	Serial No.	Characteristics	Calibration Date	Test Date	Due Date	Remark
EMI Test Receiver	R&S	ESCI	100534	9kHz~3GHz	Nov. 05, 2013	Sep. 17, 2014	Nov. 04, 2014	Radiation (03CH01-KS)
Spectrum Analyzer	R&S	FSP30	101399	9kHz~30GHz	May 04, 2014	Sep. 17, 2014	May 03, 2015	Radiation (03CH01-KS)
Bilog Antenna	SCHAFFNER	CBL6112D	23182	25MHz~2GHz	Jan. 08, 2014	Sep. 17, 2014	Jan. 07, 2015	Radiation (03CH01-KS)
Double Ridge Horn Antenna	ETS-Lindgren	3117	75959	1GHz~18GHz	Jan. 08, 2014	Sep. 17, 2014	Jan. 07, 2015	Radiation (03CH01-KS)
Amplifier	com-power	PA-103A	161073	1MHz~1GHz	May 04, 2014	Sep. 17, 2014	May 03, 2015	Radiation (03CH01-KS)
Amplifier	Agilent	8449B	3008A02371	1GHz~26.5GHz	Dec. 10, 2013	Sep. 17, 2014	Dec. 09, 2014	Radiation (03CH01-KS)
AC Power Source	Chroma	61601	F104090004	N/A	NCR	Sep. 17, 2014	NCR	Radiation (03CH01-KS)
Turn Table	MF	MF7802	N/A	0~360 degree	NCR	Sep. 17, 2014	NCR	Radiation (03CH01-KS)
Antenna Mast	MF	MF7802	N/A	1 m~4 m	NCR	Sep. 17, 2014	NCR	Radiation (03CH01-KS)
EMI Receiver	R&S	ESCI7	100768	9kHz~7GHz;	May 04, 2014	Sep. 18, 2014	May 03, 2015	Conduction (CO01-KS)
AC LISN	MessTec	AN3016	060103	9kHz~30MHz	Dec. 10, 2013	Sep. 18, 2014	Dec. 09, 2014	Conduction (CO01-KS)
AC LISN (for auxiliary equipment)	MessTec	AN3016	060105	9kHz~30MHz	Dec. 10, 2013	Sep. 18, 2014	Dec. 09, 2014	Conduction (CO01-KS)
AC Power Source	Chroma	61602	ABP0000008 11	AC 0V~300V, 45Hz~1000Hz	Nov. 12, 2013	Sep. 18, 2014	Nov. 11, 2014	Conduction (CO01-KS)



## 5. Uncertainty of Evaluation

### Uncertainty of Conducted Emission Measurement (150 kHz ~ 30 MHz)

Measuring Uncertainty for a Level of Confidence of 95% ( $U = 2Uc(y)$ )	2.3
-------------------------------------------------------------------------	-----

### Uncertainty of Radiated Emission Measurement (30 MHz ~ 1000 MHz)

Measuring Uncertainty for a Level of Confidence of 95% ( $U = 2Uc(y)$ )	2.5
-------------------------------------------------------------------------	-----