

# FCC Test Report

**APPLICANT** : Brightstar Corporation  
**EQUIPMENT** : Mobile phone  
**BRAND NAME** : Avvio  
**MODEL NAME** : Avvio 710  
**FCC ID** : WVBA710  
**STANDARD** : FCC 47 CFR FCC Part 15 Subpart B  
**CLASSIFICATION** : Certification

The product was received on Mar. 16, 2012 and completely tested on Apr. 12, 2012. We, SPORTON INTERNATIONAL (KUNSHAN) INC., would like to declare that the tested sample has been evaluated in accordance with the procedures given in ANSI C63.4-2003 and shown the compliance with the applicable technical standards.

The test results in this report apply exclusively to the tested model / sample. Without written approval of SPORTON INTERNATIONAL (KUNSHAN) INC., the test report shall not be reproduced except in full.

Reviewed by:



Jones Tsai / Manager



**SPORTON INTERNATIONAL (KUNSHAN) INC.**  
**No. 3-2, PingXiang Road, Kunshan, Jiangsu Province, P.R.C.**



## TABLE OF CONTENTS

**REVISION HISTORY..... 3**

**SUMMARY OF TEST RESULT ..... 4**

**1. GENERAL DESCRIPTION ..... 5**

    1.1. Applicant..... 5

    1.2. Manufacturer ..... 5

    1.3. Feature of Equipment Under Test..... 5

    1.4. Test Site ..... 6

    1.5. Applied Standards ..... 6

    1.6. Ancillary Equipment List..... 7

**2. TEST CONFIGURATION OF EQUIPMENT UNDER TEST ..... 8**

    2.1. Test Mode ..... 8

    2.2. Connection Diagram of Test System ..... 10

    2.3. Test Software ..... 12

**3. TEST RESULT ..... 13**

    3.1. Test of AC Conducted Emission Measurement ..... 13

    3.2. Test of Radiated Emission Measurement ..... 19

**4. LIST OF MEASURING EQUIPMENT ..... 24**

**5. UNCERTAINTY OF EVALUATION ..... 25**

**APPENDIX A. PHOTOGRAPHS OF EUT**

**APPENDIX B. SETUP PHOTOGRAPHS**





### SUMMARY OF TEST RESULT

| Report Section | FCC Rule | Description           | Limit           | Result | Remark   |
|----------------|----------|-----------------------|-----------------|--------|--|
| 3.1            | 15.107   | AC Conducted Emission | < 15.107 limits | PASS   | Under limit 1.17 dB at 0.98 MHz  |
| 3.2            | 15.109   | Radiated Emission     | < 15.109 limits | PASS   | Under limit 2.24 dB at 240.06 MHz for peak<br>Under limit 1.50 dB at 240.06 MHz for Quasi-Peak |

# 1. General Description

## 1.1. Applicant

**Brightstar Corporation**  
 9725 NW 117th Ave., Miami, Florida, United States

## 1.2. Manufacturer

**Konka Telecommunications Techenology co., LTD.**  
 Overseas Chinese Town, Nanshan District, Shenzhen, China

## 1.3. Feature of Equipment Under Test

| Product Feature & Specification |  |
|---------------------------------|--|
| <b>Equipment</b>                | Mobile phone   |
| <b>Brand Name</b>               | Avvio  |
| <b>Model Name</b>               | Avvio 710  |
| <b>FCC ID</b>                   | WVBA710  |
| <b>Tx Frequency Range</b>       | GSM850 : 824 MHz ~ 849 MHz<br>GSM1900 : 1850 MHz ~ 1910 MHz<br>Bluetooth : 2402 MHz ~ 2480 MHz<br>WLAN : 2412 MHz ~ 2462 MHz   |
| <b>Rx Frequency Range</b>       | GSM850 : 869 MHz ~ 894 MHz<br>GSM1900 : 1930 MHz ~ 1990 MHz<br>Bluetooth : 2402 MHz ~ 2480 MHz<br>WLAN : 2412 MHz ~ 2462 MHz   |
| <b>Antenna Type</b>             | WWAN : Fixed Internal Antenna<br>Bluetooth : Dipole Antenna<br>WLAN : Dipole Antenna   |
| <b>HW Version</b>               | V1.0   |
| <b>SW Version</b>               | KAAT519_INA_EN_HI_0_01_603   |
| <b>Type of Modulation</b>       | GSM / GPRS: GMSK<br>Bluetooth (1Mbps) : GFSK<br>Bluetooth EDR (2Mbps) : $\pi/4$ -DQPSK<br>Bluetooth EDR (3Mbps) : 8-DPSK<br>802.11b : DSSS (BPSK / QPSK / CCK)<br>802.11g : OFDM (BPSK / QPSK / 16QAM / 64QAM) |
| <b>EUT Stage</b>                | Production Unit  |

**Remark:** The above EUT's information was declared by manufacturer. Please refer to the specifications or user's manual for more detailed description.

### 1.4. Test Site

|                           |   |  |
|---------------------------|---|--|
| <b>Test Site</b>          | SPORTON INTERNATIONAL (SHENZHEN) INC.   |  |
| <b>Test Site Location</b> | No. 101, Complex Building C, Guanglong Village, Xili Town,<br>Nanshan District, Shenzhen, Guangdong, P.R.C.<br>TEL: +86-755-8637-9589<br>FAX: +86-755-8637-9595 |  |
| <b>Test Site No.</b>      | <b>Sporton Site No. :</b><br>CO01-SZ  |  |

|                           |  |  |
|---------------------------|--|--|
| <b>Test Site</b>          | SPORTON INTERNATIONAL (KUNSHAN) INC.   |  |
| <b>Test Site Location</b> | No. 3-2, PingXiang Road, Kunshan, Jiangsu Province, P.R.C.<br>TEL: +86-0512-5790-0158<br>FAX: +86-0512-5790-0958 |  |
| <b>Test Site No.</b>      | <b>Sporton Site No.</b><br>03CH01-KS   | <b>FCC/IC Registration No.</b><br>149928/4086E-1 |

### 1.5. Applied Standards

According to the specifications of the manufacturer, the EUT must comply with the requirements of the following standards:

- FCC 47 CFR FCC Part 15 Subpart B
- ANSI C63.4-2003

**Remark:** All test items were verified and recorded according to the standards and without any deviation during the test.

## 1.6. Ancillary Equipment List

| Item | Equipment                   | Trade Name | Model Name     | FCC ID      | Data Cable                | Power Cord   |
|------|-----------------------------|------------|----------------|-------------|---------------------------|--|
| 1.   | System Simulator            | R&S        | CMU 200        | N/A         | N/A                       | Unshielded, 1.8 m  |
| 2.   | System Simulator            | Agilent    | E5515C         | N/A         | N/A                       | Unshielded, 1.8 m  |
| 3.   | Signal Generator            | R&S        | SMR40          | N/A         | N/A                       | Unshielded, 1.8 m  |
| 4.   | PSG Analog Signal Generator | Agilent    | E8257D         | N/A         | N/A                       | Unshielded, 1.8 m  |
| 5.   | PC                          | DELL       | DCSM           | FCC DoC     | N/A                       | Unshielded, 1.8 m  |
| 6.   | Monitor                     | DELL       | E1910Hc        | FCC DoC     | Shielded, 1.2 m           | Unshielded, 1.8 m  |
| 7.   | Monitor                     | DELL       | 1707FPt        | FCC DoC     | Shielded, 1.2 m           | Unshielded, 1.8 m  |
| 8.   | (USB)Mouse                  | DELL       | MO56UC         | FCC DoC     | Shielded, 1.8 m           | N/A  |
| 9.   | (USB)Keyboard               | DELL       | SK-8115        | FCC DoC     | Shielded, 1.8 m with Core | N/A  |
| 10.  | Printer                     | HP         | Laser Jet 1018 | FCC DoC     | Shielded, 1.8 m           | N/A  |
| 11.  | iPod                        | Apple      | A1199          | FCC DoC     | Shielded, 1.2 m           | N/A  |
| 12.  | iPod                        | Apple      | MC525 ZP/A     | FCC DoC     | Shielded, 1.0 m           | N/A  |
| 13.  | Bluetooth Earphone          | Nokia      | BH-102         | PYAHS-107W  | N/A                       | N/A  |
| 14.  | Bluetooth Earphone          | Nokia      | BH-108         | N/A         | N/A                       | N/A  |
| 15.  | Earphone                    | Eimuse     | E-500MV        | FCC DoC     | Shielded, 2.2 m           | N/A  |
| 16.  | Router                      | D-Link     | DIR-855        | KA2DIR855A2 | N/A                       | Unshielded, 1.8 m  |
| 17.  | Router                      | Hometek    | NW616          | N/A         | N/A                       | Unshielded, 1.8 m  |
| 18.  | Notebook                    | DELL       | VOSTRO 1440    | FCC DoC     | N/A                       | AC I/P:<br>Unshielded, 1.8 m<br>DC O/P:<br>Shielded, 1.8 m |

## 2. Test Configuration of Equipment Under Test

### 2.1. Test Mode

The EUT has been associated with peripherals pursuant to ANSI C63.4-2003 and configuration operated in a manner tended to maximize its emission characteristics in a typical application.

Frequency range investigated: conduction (150 KHz to 30 MHz), radiation (30MHz to the 5th harmonic of the highest fundamental frequency or to 40 GHz, whichever is lower).

The following tables are showing the test modes as the worst cases and recorded in this report.

| Item | EUT Configuration  | Test Condition |           |           |
|------|--|----------------|-----------|-----------|
|      |  | EMI AC         | EMI RE<1G | EMI RE≥1G |
| 1.   | Charging Mode (EUT with adapter)                           | ☒              | ☒         | Note 1    |
| 2.   | Data application transferred mode (EUT with notebook / PC) | ☒              | ☒         | ☒         |

**Abbreviations:**

- EMI AC: AC conducted emissions
- EMI RE ≥ 1G: EUT radiated emissions ≥ 1GHz
- EMI RE < 1G: EUT radiated emissions < 1GHz

**Note 1:** Testing for this mode is not required or not the worst case.



| Test Items   | EUT Configure Mode | Function Type   |
|--|--------------------|---|
| AC Conducted Emission  | 1/2                | Mode 1: GSM850 Idle + Bluetooth Idle + WLAN Idle + Earphone + Adapter + Camera<br>Mode 2: <b>GSM1900 Idle + Bluetooth Idle + WLAN Idle + Earphone + Adapter + MP3</b><br>Mode 3: GSM850 Idle + Bluetooth Idle + WLAN Idle + Earphone + Adapter + FM Rx<br>Mode 4: <b>GSM1900 Idle + Bluetooth Idle + WLAN Idle + Earphone + USB Cable (Data Link with Notebook)</b> |
| Radiated Emissions < 1GHz  | 1/2                | Mode 1: GSM850 Idle + Bluetooth Idle + WLAN Idle + Earphone + Adapter + Camera<br>Mode 2: GSM1900 Idle + Bluetooth Idle + WLAN Idle + Earphone + Adapter + MP3<br>Mode 3: GSM850 Idle + Bluetooth Idle + WLAN Idle + Earphone + Adapter + FM Rx<br>Mode 4: <b>GSM1900 Idle + Bluetooth Idle + WLAN Idle + Earphone + USB Cable (Data Link with PC)</b>              |
| Radiated Emissions ≥ 1GHz  | 2                  | Mode 1: GSM1900 Idle + Bluetooth Idle + WLAN Idle + Earphone + USB Cable (Data Link with PC)  |
| <b>Remark:</b> <ol style="list-style-type: none"> <li>The worst case of AC is mode 2, the test data of this mode was reported; and mode 4 that for data exchange mode was also reported.</li> <li>The worst case of RE &lt; 1G is mode 4; only the test data of this mode was reported.</li> <li>Link with Notebook / PC means data application transferred mode between EUT and Notebook / PC.</li> </ol> |                    |   |

## 2.2. Connection Diagram of Test System

<EUT with Adapter Mode>

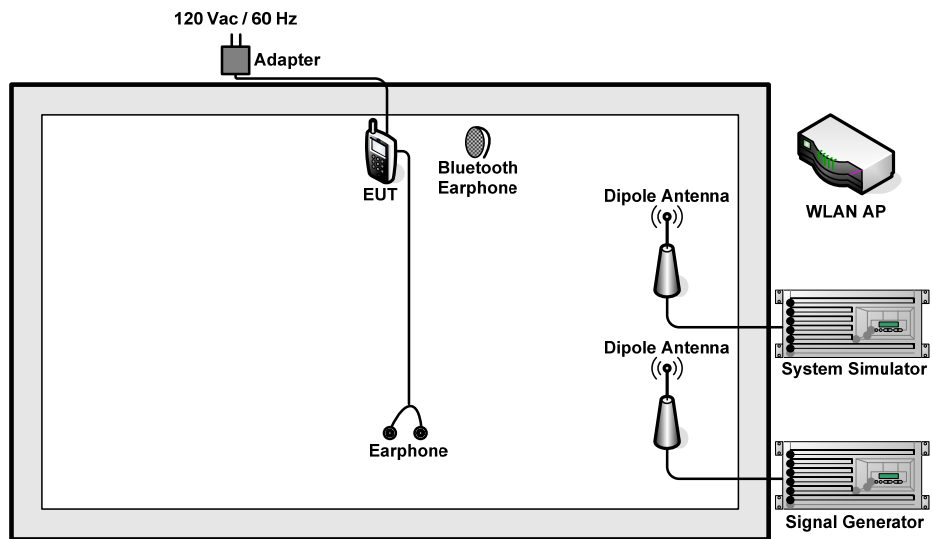
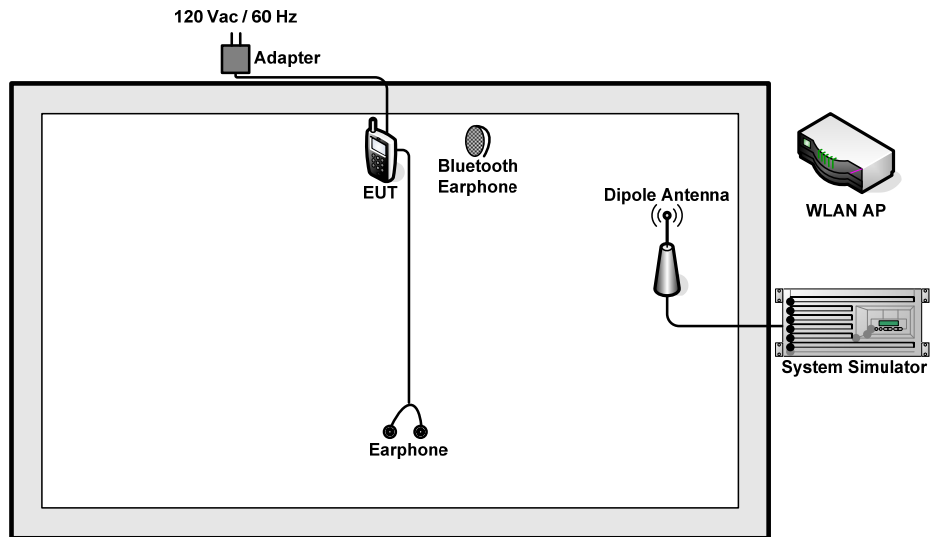

<EUT with USB Cable (Data Link with PC) Mode>

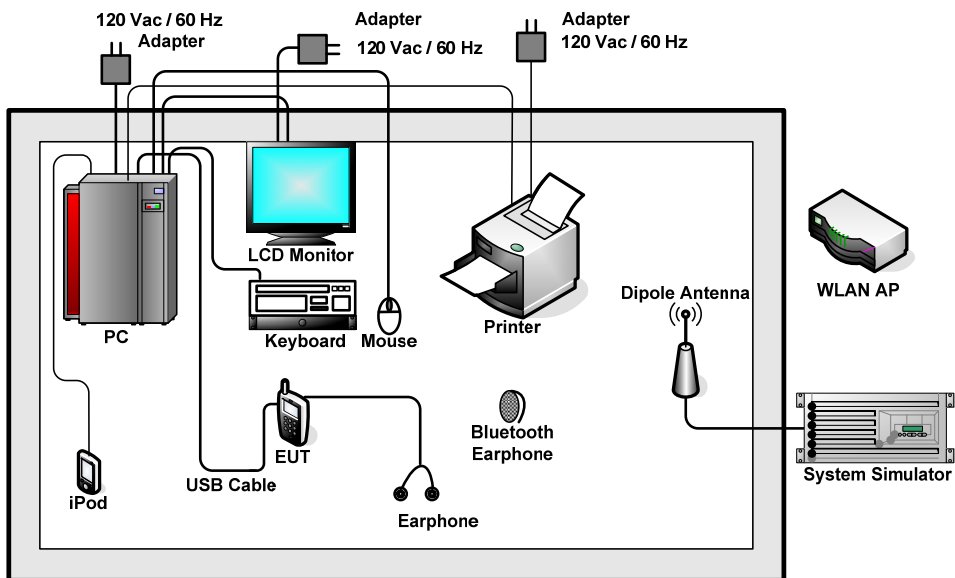

<EUT with USB Cable (Data Link with Notebook) Mode>

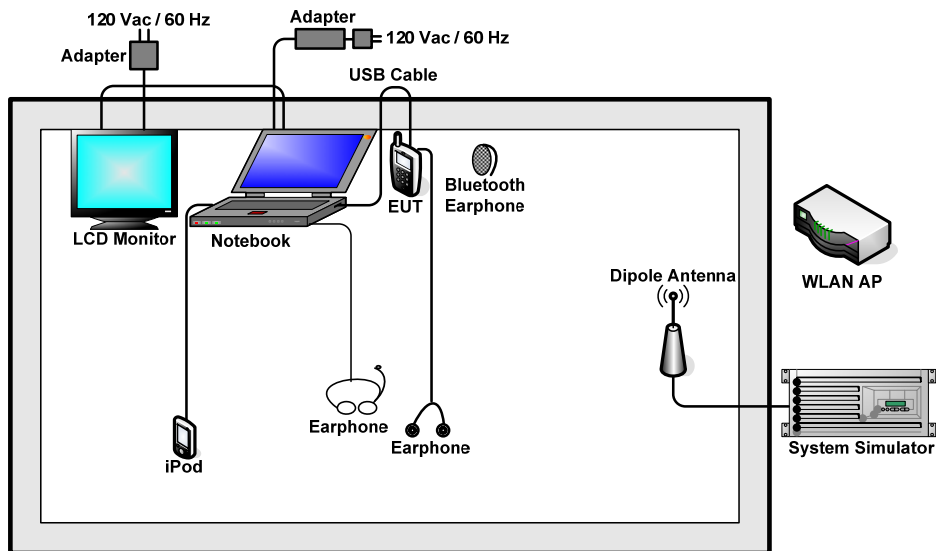

## 2.3. Test Software

The EUT was in GSM idle mode during the testing. The EUT was synchronized to the BCCH, and is in continuous receiving mode by setting system simulator's paging reorganization.

At the same time, the EUT was attached to the Bluetooth earphone or WLAN AP, and the following programs installed in the EUT were programmed during the test.

1. Execute the program, "Winthrax", installed in notebook or PC for active sync files transfer with EUT via USB cable / iPod.
2. Execute "Music Player" to play MP3 file.
3. Turn on camera to capture images.
4. Turn on FM function to make EUT receiving signals continuously from signal generator.
5. Keep EUT transmitting and receiving signals continuously from system simulator.

### 3. Test Result

#### 3.1. Test of AC Conducted Emission Measurement

##### 3.1.1 Limits of AC Conducted Emission

For equipment that is designed to be connected to the public utility (AC) power line, the radio frequency voltage that is conducted back onto the AC power line on any frequency or frequencies within the band 150 KHz to 30 MHz shall not exceed the limits in the following table.

| Frequency of emission<br>(MHz) | Conducted limit (dBuV) |           |
|--------------------------------|------------------------|-----------|
|                                | Quasi-peak             | Average   |
| 0.15-0.5                       | 66 to 56*              | 56 to 46* |
| 0.5-5                          | 56                     | 46        |
| 5-30                           | 60                     | 50        |

\*Decreases with the logarithm of the frequency.

##### 3.1.2 Measuring Instruments

See list of measuring instruments of this test report.

##### 3.1.3 Test Procedure

1. The EUT was placed 0.4 meter from the conducting wall of the shielding room was kept at least 80 centimeters from any other grounded conducting surface.
2. The EUT link with notebook / PC, connect notebook / PC to the power mains through a line impedance stabilization network (LISN).
3. All the support units are connecting to the other LISN.
4. The LISN provides 50 ohm coupling impedance for the measuring instrument.
5. The FCC states that a 50 ohm, 50 microhenry LISN should be used.
6. Both sides of AC line were checked for maximum conducted interference.
7. The frequency range from 150 KHz to 30 MHz was searched.
8. Set the test-receiver system to Peak Detect Function and specified bandwidth with Maximum Hold Mode.

### 3.1.4 Test Setup

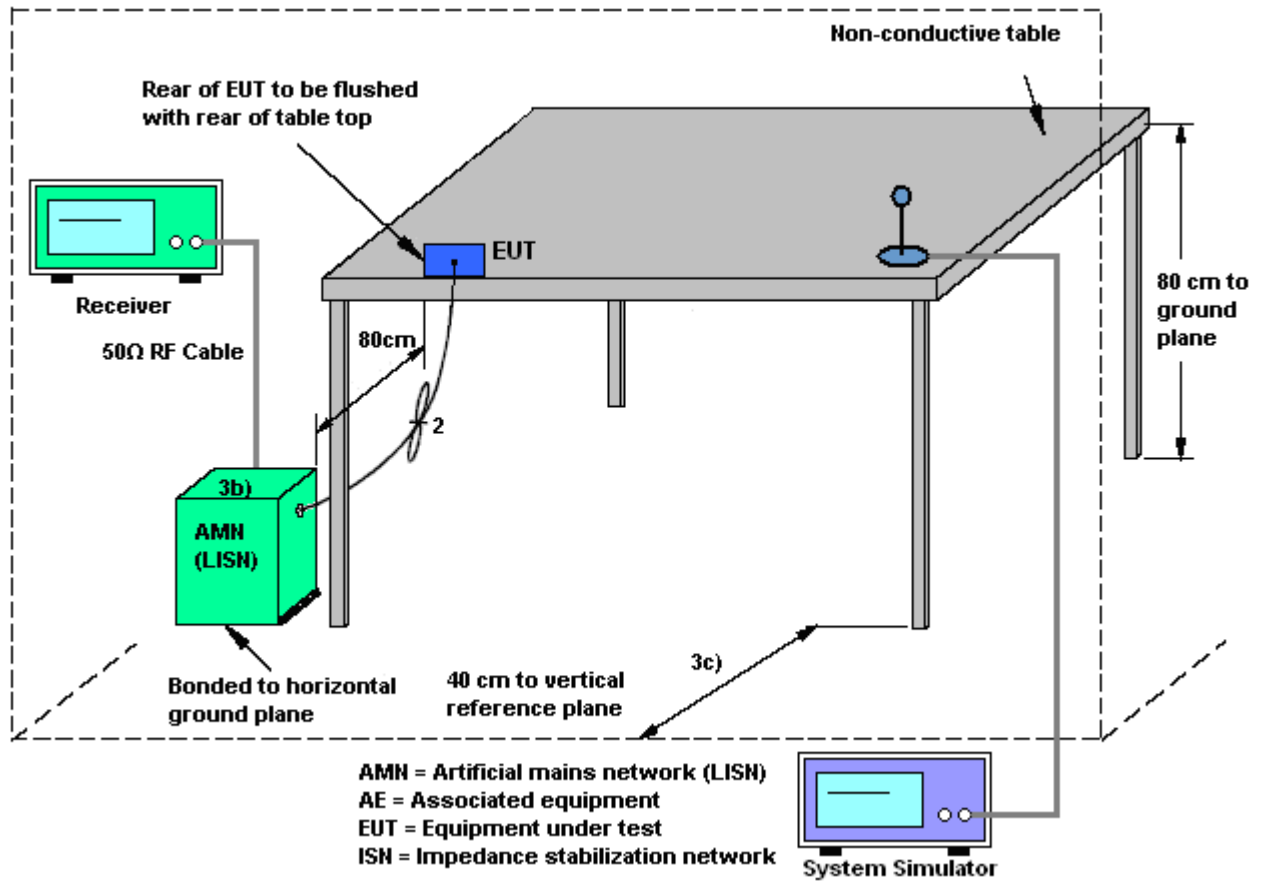



3.1.5 Test Result of AC Conducted Emission

|                 |   |                     |         |
|-----------------|---|---------------------|---------|
| Test Mode :     | Mode 2  | Temperature :       | 22~23°C |
| Test Engineer : | Neaps Wang  | Relative Humidity : | 44~46%  |
| Test Voltage :  | 120Vac / 60Hz   | Phase :             | Line    |
| Function Type : | GSM1900 Idle + Bluetooth Idle + WLAN Idle + Earphone + Adapter + MP3            |                     |         |
| Remark :        | All emissions not reported here are more than 10 dB below the prescribed limit. |                     |         |

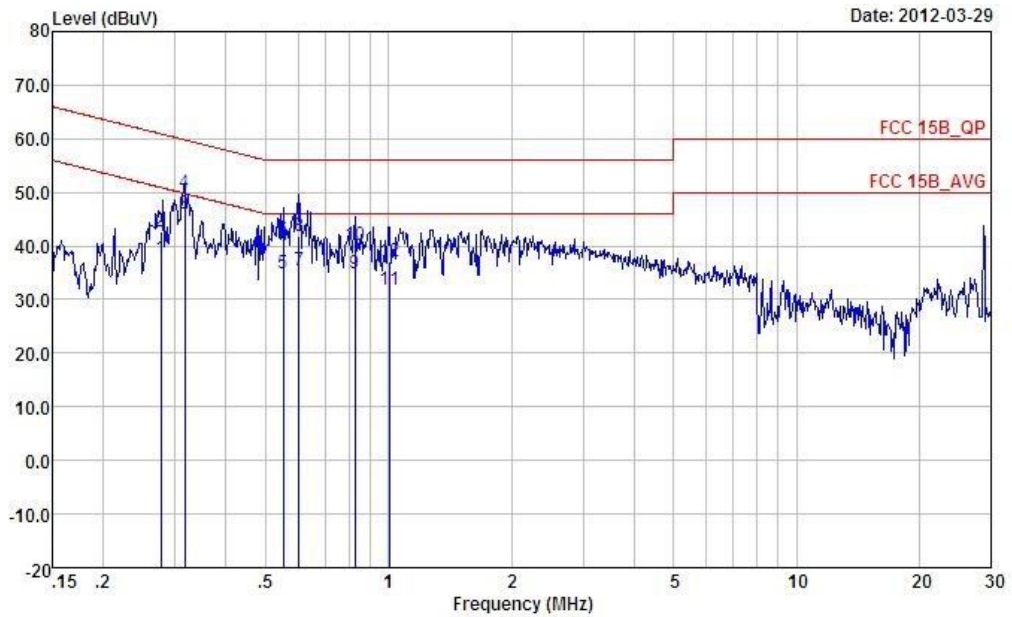

Site : CO01-SZ  
 Condition : FCC 15B\_QP LISN\_L\_2000601 LINE  
 Project : (FC)231611  
 Mode : Mode2

|    | Freq | Level | Over Limit | Limit Line | Read Level | LISN Factor | Cable Loss | Remark  |
|----|------|-------|------------|------------|------------|-------------|------------|---------|
|    | MHz  | dBuV  | dB         | dBuV       | dBuV       | dB          | dB         |         |
| 1  | 0.28 | 37.68 | -13.22     | 50.90      | 27.60      | 0.02        | 10.06      | Average |
| 2  | 0.28 | 42.58 | -18.32     | 60.90      | 32.50      | 0.02        | 10.06      | QP      |
| 3  | 0.32 | 46.09 | -3.71      | 49.80      | 36.00      | 0.02        | 10.07      | Average |
| 4  | 0.32 | 49.89 | -9.91      | 59.80      | 39.80      | 0.02        | 10.07      | QP      |
| 5  | 0.55 | 35.01 | -10.99     | 46.00      | 24.90      | 0.02        | 10.09      | Average |
| 6  | 0.55 | 41.31 | -14.69     | 56.00      | 31.20      | 0.02        | 10.09      | QP      |
| 7  | 0.60 | 35.52 | -10.48     | 46.00      | 25.41      | 0.02        | 10.09      | Average |
| 8  | 0.60 | 41.82 | -14.18     | 56.00      | 31.71      | 0.02        | 10.09      | QP      |
| 9  | 0.83 | 34.83 | -11.17     | 46.00      | 24.70      | 0.02        | 10.11      | Average |
| 10 | 0.83 | 40.23 | -15.77     | 56.00      | 30.10      | 0.02        | 10.11      | QP      |
| 11 | 1.00 | 31.84 | -14.16     | 46.00      | 21.70      | 0.03        | 10.11      | Average |
| 12 | 1.00 | 37.04 | -18.96     | 56.00      | 26.90      | 0.03        | 10.11      | QP      |



|                 |   |                     |         |
|-----------------|---|---------------------|---------|
| Test Mode :     | Mode 2  | Temperature :       | 22~23°C |
| Test Engineer : | Neaps Wang  | Relative Humidity : | 44~46%  |
| Test Voltage :  | 120Vac / 60Hz   | Phase :             | Neutral |
| Function Type : | GSM1900 Idle + Bluetooth Idle + WLAN Idle + Earphone + Adapter + MP3            |                     |         |
| Remark :        | All emissions not reported here are more than 10 dB below the prescribed limit. |                     |         |

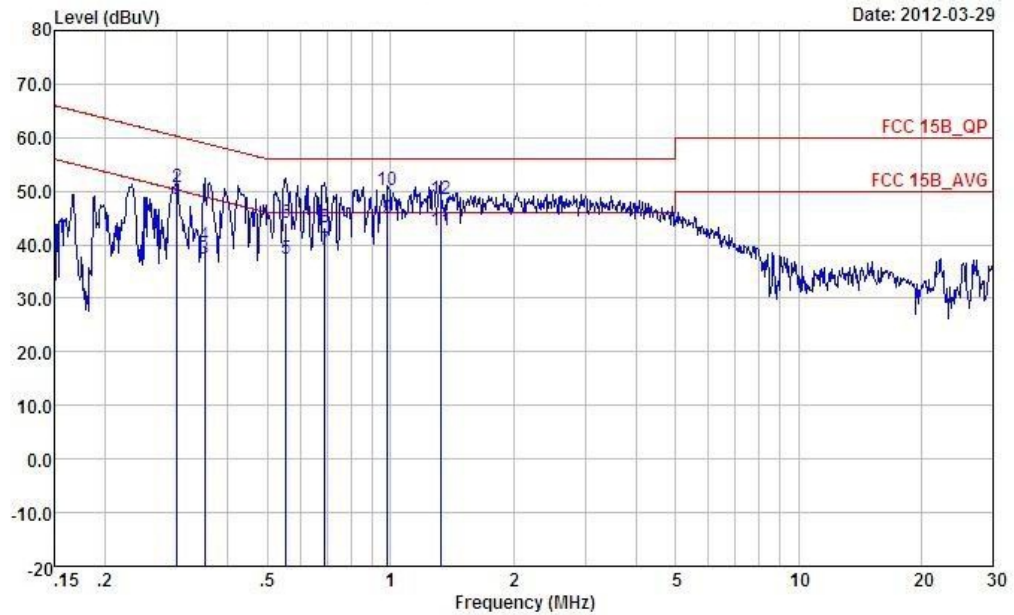

Site : CO01-SZ  
 Condition : FCC 15B\_QP LISN\_N\_2000601 NEUTRAL  
 Project : (FC)231611  
 Mode : Mode2

|    | Freq | Level | Over Limit | Limit Line | Read Level | LISN Factor | Cable Loss | Remark  |
|----|------|-------|------------|------------|------------|-------------|------------|---------|
|    | MHz  | dBuV  | dB         | dBuV       | dBuV       | dB          | dB         |         |
| 1  | 0.30 | 46.78 | -3.46      | 50.24      | 36.70      | 0.02        | 10.06      | Average |
| 2  | 0.30 | 50.68 | -9.56      | 60.24      | 40.60      | 0.02        | 10.06      | QP      |
| 3  | 0.35 | 37.29 | -11.67     | 48.96      | 27.20      | 0.02        | 10.07      | Average |
| 4  | 0.35 | 39.89 | -19.07     | 58.96      | 29.80      | 0.02        | 10.07      | QP      |
| 5  | 0.56 | 37.51 | -8.49      | 46.00      | 27.40      | 0.02        | 10.09      | Average |
| 6  | 0.56 | 44.01 | -11.99     | 56.00      | 33.90      | 0.02        | 10.09      | QP      |
| 7  | 0.69 | 39.02 | -6.98      | 46.00      | 28.90      | 0.02        | 10.10      | Average |
| 8  | 0.69 | 43.22 | -12.78     | 56.00      | 33.10      | 0.02        | 10.10      | QP      |
| 9  | 0.98 | 44.83 | -1.17      | 46.00      | 34.70      | 0.02        | 10.11      | Average |
| 10 | 0.98 | 50.33 | -5.67      | 56.00      | 40.20      | 0.02        | 10.11      | QP      |
| 11 | 1.32 | 42.55 | -3.45      | 46.00      | 32.41      | 0.02        | 10.12      | Average |
| 12 | 1.32 | 48.55 | -7.45      | 56.00      | 38.41      | 0.02        | 10.12      | QP      |





|                 |  |                     |         |
|-----------------|--|---------------------|---------|
| Test Mode :     | Mode 4   | Temperature :       | 22~23°C |
| Test Engineer : | Neaps Wang   | Relative Humidity : | 44~46%  |
| Test Voltage :  | 120Vac / 60Hz  | Phase :             | Line    |
| Function Type : | GSM1900 Idle + Bluetooth Idle + WLAN Idle + Earphone + USB Cable (Data Link with Notebook) |                     |         |
| Remark :        | All emissions not reported here are more than 10 dB below the prescribed limit.            |                     |         |

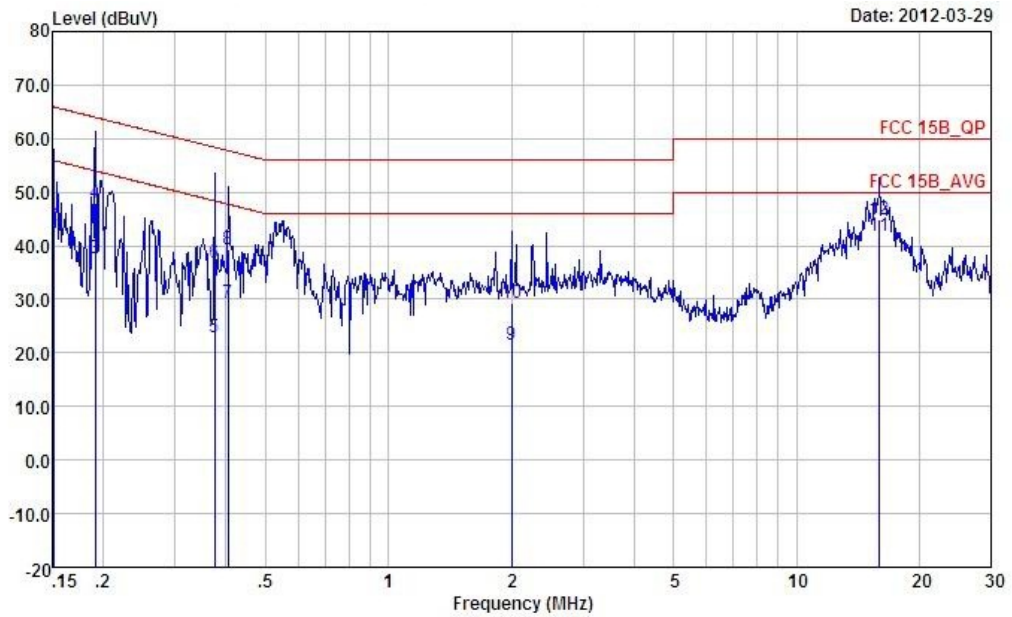

Site : CO01-SZ  
 Condition : FCC 15B\_QP LISN\_L\_2000601 LINE  
 Project : (FC)231611  
 Mode : Mode4

|    | Freq  | Level | Over   | Limit | Read  | LISN   | Cable | Remark  |
|----|-------|-------|--------|-------|-------|--------|-------|---------|
|    | MHz   | dBuV  | Limit  | Line  | Level | Factor | Loss  |         |
|    |       |       | dB     | dBuV  | dBuV  | dB     | dB    |         |
| 1  | 0.15  | 41.78 | -14.18 | 55.96 | 31.70 | 0.03   | 10.05 | Average |
| 2  | 0.15  | 43.78 | -22.18 | 65.96 | 33.70 | 0.03   | 10.05 | QP      |
| 3  | 0.19  | 37.78 | -16.20 | 53.98 | 27.70 | 0.03   | 10.05 | Average |
| 4  | 0.19  | 47.98 | -16.00 | 63.98 | 37.90 | 0.03   | 10.05 | QP      |
| 5  | 0.38  | 22.80 | -25.59 | 48.39 | 12.71 | 0.02   | 10.07 | Average |
| 6  | 0.38  | 36.70 | -21.69 | 58.39 | 26.61 | 0.02   | 10.07 | QP      |
| 7  | 0.40  | 29.30 | -18.47 | 47.77 | 19.20 | 0.02   | 10.08 | Average |
| 8  | 0.40  | 39.40 | -18.37 | 57.77 | 29.30 | 0.02   | 10.08 | QP      |
| 9  | 2.00  | 21.39 | -24.61 | 46.00 | 11.20 | 0.04   | 10.15 | Average |
| 10 | 2.00  | 29.29 | -26.71 | 56.00 | 19.10 | 0.04   | 10.15 | QP      |
| 11 | 15.97 | 41.83 | -8.17  | 50.00 | 31.11 | 0.26   | 10.46 | Average |
| 12 | 15.97 | 44.93 | -15.07 | 60.00 | 34.21 | 0.26   | 10.46 | QP      |



|                 |  |                     |         |
|-----------------|--|---------------------|---------|
| Test Mode :     | Mode 4   | Temperature :       | 22~23°C |
| Test Engineer : | Neaps Wang   | Relative Humidity : | 44~46%  |
| Test Voltage :  | 120Vac / 60Hz  | Phase :             | Neutral |
| Function Type : | GSM1900 Idle + Bluetooth Idle + WLAN Idle + Earphone + USB Cable (Data Link with Notebook) |                     |         |
| Remark :        | All emissions not reported here are more than 10 dB below the prescribed limit.            |                     |         |

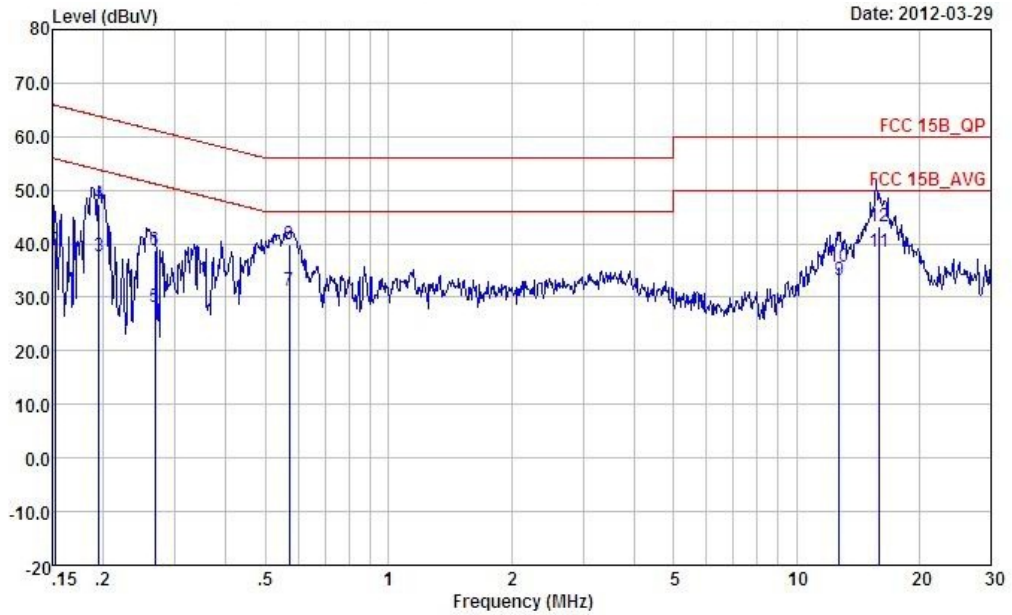

Site : CO01-SZ  
 Condition : FCC 15B\_QP LISN\_N\_2000601 NEUTRAL  
 Project : (FC)231611  
 Mode : Mode4

|    | Freq  | Level | Over Limit | Limit Line | Read Level | LISN Factor | Cable Loss | Remark  |
|----|-------|-------|------------|------------|------------|-------------|------------|---------|
|    | MHz   | dBuV  | dB         | dBuV       | dBuV       | dB          | dB         |         |
| 1  | 0.15  | 37.47 | -18.40     | 55.87      | 27.40      | 0.02        | 10.05      | Average |
| 2  | 0.15  | 38.87 | -27.00     | 65.87      | 28.80      | 0.02        | 10.05      | QP      |
| 3  | 0.20  | 37.77 | -16.03     | 53.80      | 27.69      | 0.02        | 10.06      | Average |
| 4  | 0.20  | 47.47 | -16.33     | 63.80      | 37.39      | 0.02        | 10.06      | QP      |
| 5  | 0.27  | 28.18 | -23.02     | 51.20      | 18.10      | 0.02        | 10.06      | Average |
| 6  | 0.27  | 38.88 | -22.32     | 61.20      | 28.80      | 0.02        | 10.06      | QP      |
| 7  | 0.57  | 31.21 | -14.79     | 46.00      | 21.10      | 0.02        | 10.09      | Average |
| 8  | 0.57  | 39.81 | -16.19     | 56.00      | 29.70      | 0.02        | 10.09      | QP      |
| 9  | 12.72 | 33.08 | -16.92     | 50.00      | 22.40      | 0.32        | 10.36      | Average |
| 10 | 12.72 | 35.78 | -24.22     | 60.00      | 25.10      | 0.32        | 10.36      | QP      |
| 11 | 15.89 | 38.63 | -11.37     | 50.00      | 27.80      | 0.37        | 10.46      | Average |
| 12 | 15.89 | 43.33 | -16.67     | 60.00      | 32.50      | 0.37        | 10.46      | QP      |

## 3.2. Test of Radiated Emission Measurement

### 3.2.1. Limit of Radiated Emission

The emissions from an intentional radiator shall not exceed the field strength levels specified in the following table:

| Frequency (MHz) | Field Strength (microvolts/meter) | Measurement Distance (meters) |
|-----------------|-----------------------------------|-------------------------------|
| 0.009 – 0.490   | 2400/F(KHz)                       | 300                           |
| 0.490 – 1.705   | 24000/F(KHz)                      | 30                            |
| 1.705 – 30.0    | 30                                | 30                            |
| 30 – 88         | 100                               | 3                             |
| 88 – 216        | 150                               | 3                             |
| 216 - 960       | 200                               | 3                             |
| Above 960       | 500                               | 3                             |

### 3.2.2. Measuring Instruments

See list of measuring instruments of this test report.



**3.2.3. Test Procedures**

1. The EUT was placed on a turntable with 0.8 meter above ground.
2. The EUT was set 3 meters from the interference receiving antenna, which was mounted on the top of a variable height antenna tower.
3. The table was rotated 360 degrees to determine the position of the highest radiation.
4. The antenna is a Bi-Log antenna and its height is adjusted between one meter and four meters above ground to find the maximum value of the field strength for both horizontal polarization and vertical polarization of the antenna.
5. For each suspected emission, the EUT was arranged to its worst case and then tune the antenna tower (from 1 m to 4 m) and turntable (from 0 degree to 360 degrees) to find the maximum reading.
6. Set the test-receiver system to Peak Detect Function and specified bandwidth with Maximum Hold Mode.
7. If the emission level of the EUT in peak mode was 3 dB lower than the limit specified, then testing will be stopped and peak values of EUT will be reported, otherwise, the emissions will be repeated one by one using the quasi-peak method and reported
8. Emission level (dBuV/m) = 20 log Emission level (uV/m)
9. Corrected Reading: Antenna Factor + Cable Loss + Read Level - Preamp Factor = Level

### 3.2.4. Test Setup of Radiated Emission

For radiated emissions below 30MHz

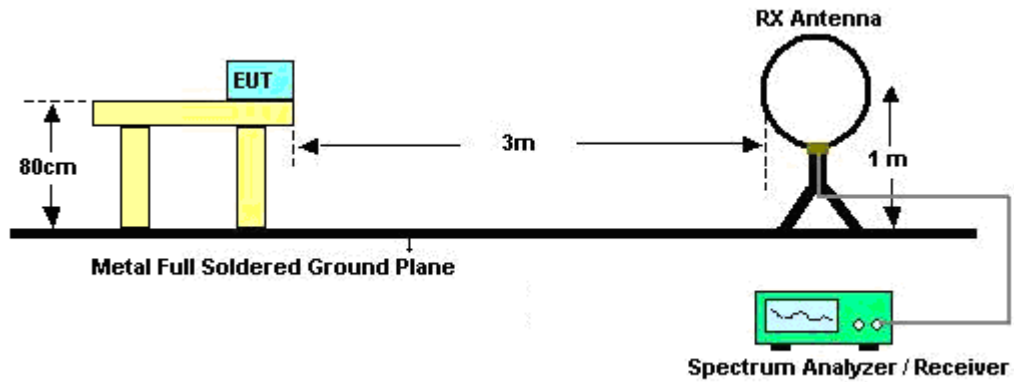

For radiated emissions above 30MHz

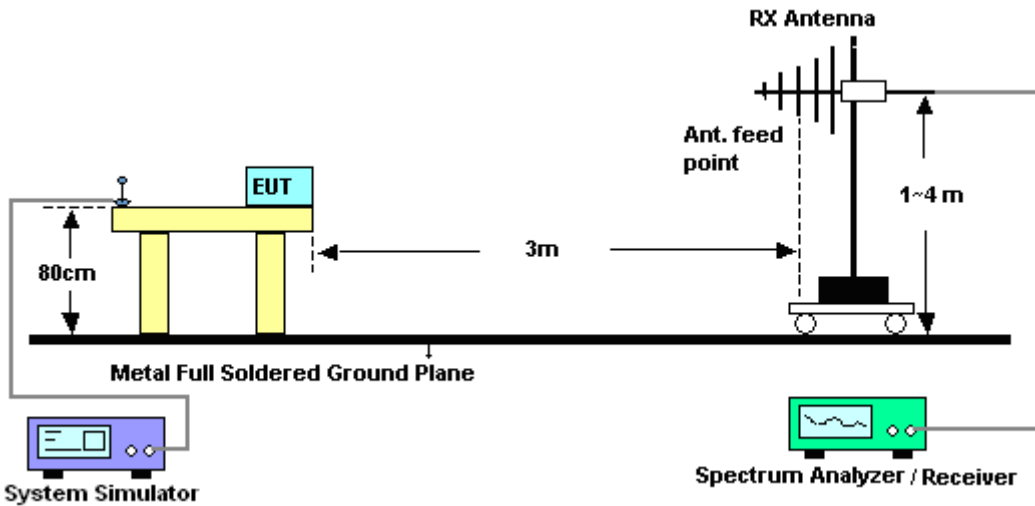

### 3.2.5. Test Results of Radiated Emissions (9 kHz ~ 30 MHz)

The low frequency, which started from 9 KHz to 30MHz, was pre-scanned and the result which was 20dB lower than the limit line per 15.31(o) was not reported.

3.2.6. Test Result of Radiated Emission

|                 |  |                     |            |
|-----------------|--|---------------------|------------|
| Test Mode :     | Mode 4   | Temperature :       | 22~23°C    |
| Test Engineer : | Chenmy Cheng   | Relative Humidity : | 45~47%     |
| Test Distance : | 3m   | Polarization :      | Horizontal |
| Function Type : | GSM1900 Idle + Bluetooth Idle + WLAN Idle + Earphone + USB Cable (Data Link with PC) |                     |            |

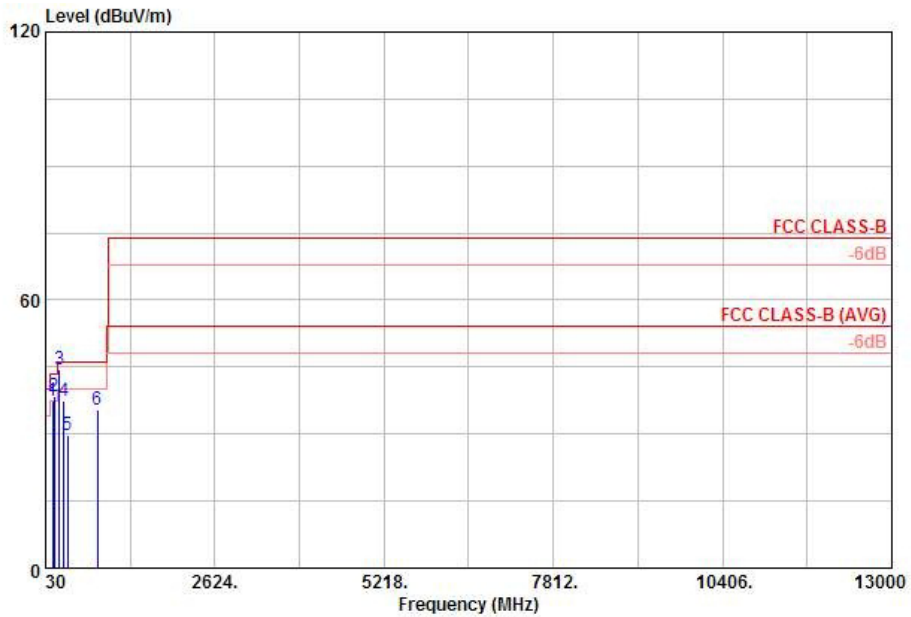

Site : 03CH01-KS  
 Condition: FCC CLASS-B 3m LF\_ANT\_100803 HORIZONTAL  
 Project : (FC) 231611  
 Mode : mode 4

|   | Freq   | Level  | Over   | Limit  | ReadAntenna | Cable | Preamp | Ant   | Table | Remark |
|---|--------|--------|--------|--------|-------------|-------|--------|-------|-------|--------|
|   | MHz    | dBuV/m | dB     | dBuV/m | dBuV        | dB    | dB     | cm    | deg   |        |
| 1 | 143.94 | 37.56  | -5.94  | 43.50  | 56.50       | 10.55 | 0.50   | 29.99 | ---   | Peak   |
| 2 | 165.54 | 38.44  | -5.06  | 43.50  | 58.46       | 9.36  | 0.54   | 29.92 | ---   | Peak   |
| 3 | 240.06 | 44.50  | -1.50  | 46.00  | 62.10       | 11.56 | 0.66   | 29.82 | 100   | 28 QP  |
| 4 | 314.70 | 37.51  | -8.49  | 46.00  | 53.33       | 13.38 | 0.75   | 29.95 | ---   | Peak   |
| 5 | 368.60 | 29.60  | -16.40 | 46.00  | 43.69       | 14.98 | 0.83   | 29.90 | ---   | Peak   |
| 6 | 827.80 | 35.39  | -10.61 | 46.00  | 43.53       | 20.22 | 1.27   | 29.63 | ---   | Peak   |



|                 |  |                     |          |
|-----------------|--|---------------------|----------|
| Test Mode :     | Mode 4   | Temperature :       | 22~23°C  |
| Test Engineer : | Chenmy Cheng   | Relative Humidity : | 45~47%   |
| Test Distance : | 3m   | Polarization :      | Vertical |
| Function Type : | GSM1900 Idle + Bluetooth Idle + WLAN Idle + Earphone + USB Cable (Data Link with PC) |                     |          |

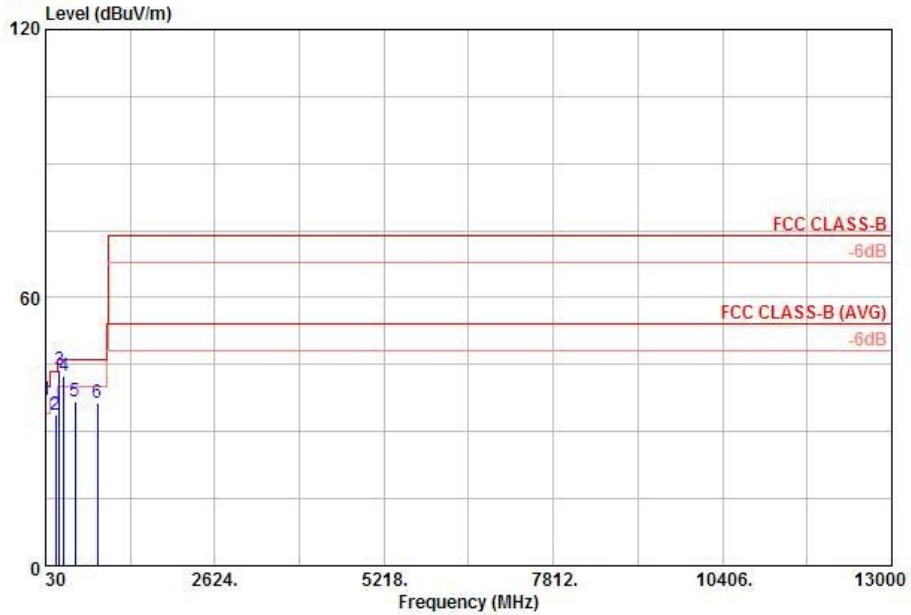

Site : 03CH01-KS  
 Condition: FCC CLASS-B 3m LF\_ANT\_100803 VERTICAL  
 Project : (FC) 231611  
 Mode : mode 4

|     | Freq   | Level  | Over  | Limit  | ReadAntenna | Cable | Preamp | Ant   | Table | Remark   |
|-----|--------|--------|-------|--------|-------------|-------|--------|-------|-------|----------|
|     | MHz    | dBuV/m | dB    | dBuV/m | dBuV        | dB/m  | dB     | cm    | deg   |          |
| 1 ! | 31.89  | 37.14  | -2.86 | 40.00  | 50.44       | 16.55 | 0.24   | 30.09 | ---   | Peak     |
| 2   | 186.33 | 33.88  | -9.62 | 43.50  | 54.77       | 8.46  | 0.57   | 29.92 | ---   | Peak     |
| 3 ! | 240.06 | 43.76  | -2.24 | 46.00  | 61.36       | 11.56 | 0.66   | 29.82 | 100   | 182 Peak |
| 4 ! | 314.00 | 42.48  | -3.52 | 46.00  | 58.33       | 13.36 | 0.74   | 29.95 | ---   | Peak     |
| 5   | 479.90 | 36.93  | -9.07 | 46.00  | 48.87       | 16.87 | 0.94   | 29.75 | ---   | Peak     |
| 6   | 827.80 | 36.29  | -9.71 | 46.00  | 44.43       | 20.22 | 1.27   | 29.63 | ---   | Peak     |

## 4. List of Measuring Equipment

| Instrument                         | Manufacturer     | Model No.        | Serial No.          | Characteristics        | Calibration Date | Test Date     | Due Date      | Remark                   |
|------------------------------------|------------------|------------------|---------------------|------------------------|------------------|---------------|---------------|--------------------------|
| AC LISN                            | ETS-LINDGR<br>EN | 3816/2SH         | 00103912            | 0.1MHz~108MHz          | Feb. 27, 2012    | Mar. 29, 2012 | Feb. 26, 2013 | Conduction<br>(CO01-SZ)  |
| AC LISN                            | ETS-LINDGR<br>EN | 3816/2SH         | 00103892            | 0.1MHz~108MHz          | Feb. 27, 2012    | Mar. 29, 2012 | Feb. 26, 2013 | Conduction<br>(CO01-SZ)  |
| ESCIO TEST<br>Receiver             | R&S              | 1142.8007.<br>03 | 100724              | 9K-3GHz                | Mar. 07, 2012    | Mar. 29, 2012 | Mar. 06, 2013 | Conduction<br>(CO01-SZ)  |
| AC Power<br>Source                 | Chroma           | 61602            | 61602000089<br>1N/A | N/A                    | Oct. 12, 2011    | Mar. 29, 2012 | Oct. 11, 2012 | Conduction<br>(CO01-SZ)  |
| AC LISN                            | SCHWARZBE<br>CK  | NNLK 8121        | 8121370             | 10KHz-30MHz            | Jun. 13, 2011    | Mar. 29, 2012 | Jun. 12, 2012 | Conduction<br>(CO01-SZ)  |
| System<br>Simulator                | Agilent          | E5515C           | MY50264168          | GSM/WCDMA<br>/CDMA2000 | Sep. 04, 2011    | Mar. 29, 2012 | Sep. 03, 2012 | Conduction<br>(CO01-SZ)  |
| PSG Analog<br>Singnal<br>Generator | Agilent          | E8257D           | MY48050405          | 250KHZ-50GHZ           | Sep. 04, 2011    | Mar. 29, 2012 | Sep. 03, 2012 | Conduction<br>(CO01-SZ)  |
| EMI Test<br>Receiver               | R&S              | ESCI             | 100534              | 9kHz~3GHz              | Nov. 09, 2011    | Apr. 12, 2012 | Nov. 08, 2012 | Radiation<br>(03CH01-KS) |
| Spectrum<br>Analyzer               | R&S              | FSP40            | 100319              | 9kHz~40GHz             | Dec. 30, 2011    | Apr. 12, 2012 | Dec. 29, 2012 | Radiation<br>(03CH01-KS) |
| Bilog Antenna                      | SCHAFFNER        | CBL6112D         | 23182               | 25MHz~2GHz             | Dec. 08, 2011    | Apr. 12, 2012 | Dec. 07, 2012 | Radiation<br>(03CH01-KS) |
| Loop Antenna                       | R&S              | HFH2-Z2          | 860004/00           | 9 kHz~30 MHz           | Jul. 28, 2011    | Apr. 12, 2012 | Jul. 27, 2012 | Radiation<br>(03CH01-KS) |
| Double Ridge<br>Horn Antenna       | EMCO             | 3117             | 00075959            | 1GHz~18GHz             | Jan. 06, 2012    | Apr. 12, 2012 | Jan. 05, 2013 | Radiation<br>(03CH01-KS) |
| Amplifier                          | Wireless         | FPA-6592G        | 060007              | 30MHz~2GHz             | Dec. 30, 2011    | Apr. 12, 2012 | Dec. 29, 2012 | Radiation<br>(03CH01-KS) |
| Amplifier                          | Agilent          | 8449B            | 3008A02370          | 1GHz~26.5GHz           | Dec. 30, 2011    | Apr. 12, 2012 | Dec. 29, 2012 | Radiation<br>(03CH01-KS) |
| Signal<br>Generator                | R&S              | SMR40            | 100455              | 10GHz~40GHz            | Dec. 30, 2011    | Apr. 12, 2012 | Dec. 29, 2012 | Radiation<br>(03CH01-KS) |
| System<br>Simulator                | R&S              | CMU200           | 837587/066          | 2G Full-Band           | Dec. 30, 2011    | Apr. 12, 2012 | Dec. 29, 2012 | Radiation<br>(03CH01-KS) |



## 5. Uncertainty of Evaluation

### Uncertainty of Conducted Emission Measurement (150 KHz ~ 30 MHz)

| Contribution  | Uncertainty of $X_i$ |                          | $u(X_i)$ |
|---|----------------------|--------------------------|----------|
|   | dB                   | Probability Distribution |          |
| Receiver Reading  | 0.10                 | Normal (k=2)             | 0.05     |
| Cable Loss  | 0.10                 | Normal (k=2)             | 0.05     |
| AMN Insertion Loss  | 2.50                 | Rectangular              | 0.63     |
| Receiver Specification  | 1.50                 | Rectangular              | 0.43     |
| Site Imperfection   | 1.39                 | Rectangular              | 0.80     |
| Mismatch  | +0.34 / -0.35        | U-Shape                  | 0.24     |
| <b>Combined Standard Uncertainty <math>Uc(y)</math></b>                                 | <b>1.13</b>          |                          |          |
| <b>Measuring Uncertainty for a Level of Confidence of 95% (<math>U = 2Uc(y)</math>)</b> | <b>2.26</b>          |                          |          |

### Uncertainty of Radiated Emission Measurement (30 MHz ~ 1000 MHz)

| Contribution  | Uncertainty of $X_i$ |                          | $u(X_i)$ |
|---|----------------------|--------------------------|----------|
|   | dB                   | Probability Distribution |          |
| Receiver Reading  | 0.41                 | Normal (k=2)             | 0.21     |
| Antenna Factor Calibration  | 0.83                 | Normal (k=2)             | 0.42     |
| Cable Loss Calibration  | 0.25                 | Normal (k=2)             | 0.13     |
| Pre-Amplifier Gain Calibration  | 0.27                 | Normal (k=2)             | 0.14     |
| RCV/SPA Specification   | 2.50                 | Rectangular              | 0.72     |
| Antenna Factor Interpolation for Frequency  | 1.00                 | Rectangular              | 0.29     |
| Site Imperfection   | 1.43                 | Rectangular              | 0.83     |
| Mismatch  | +0.39 / -0.41        | U-Shape                  | 0.28     |
| <b>Combined Standard Uncertainty <math>Uc(y)</math></b>                                 | <b>1.27</b>          |                          |          |
| <b>Measuring Uncertainty for a Level of Confidence of 95% (<math>U = 2Uc(y)</math>)</b> | <b>2.54</b>          |                          |          |

**Uncertainty of Radiated Emission Measurement (1 GHz ~ 40 GHz)**

| Contribution   | Uncertainty of $X_i$ |                          | $u(X_i)$ | $C_i$ | $C_i * u(X_i)$ |
|--|----------------------|--------------------------|----------|-------|----------------|
|  | dB                   | Probability Distribution |          |       |                |
| Receiver Reading   | ±0.10                | Normal (k=2)             | 0.10     | 1     | 0.10           |
| Antenna Factor Calibration   | ±1.70                | Normal (k=2)             | 0.85     | 1     | 0.85           |
| Cable Loss Calibration   | ±0.50                | Normal (k=2)             | 0.25     | 1     | 0.25           |
| Receiver Correction  | ±2.00                | Rectangular              | 1.15     | 1     | 1.15           |
| Antenna Factor Directional   | ±1.50                | Rectangular              | 0.87     | 1     | 0.87           |
| Site Imperfection  | ±2.80                | Triangular               | 1.14     | 1     | 1.14           |
| Mismatch<br>Receiver VSWR $\Gamma_1 = 0.197$<br>Antenna VSWR $\Gamma_2 = 0.194$<br>Uncertainty = $20\text{Log}(1-\Gamma_1*\Gamma_2)$ | +0.34 / -0.35        | U-Shape                  | 0.244    | 1     | 0.244          |
| <b>Combined Standard Uncertainty<br/><math>U_c(y)</math></b>   | <b>2.36</b>          |                          |          |       |                |
| <b>Measuring Uncertainty for a<br/>Level of Confidence of 95%<br/>(<math>U = 2U_c(y)</math>)</b>                                     | <b>4.72</b>          |                          |          |       |                |



## **Appendix A. Photographs of EUT**

Please refer to Sporton report number EP231611 as below.