

# FCC Test Report

**APPLICANT** : Brightstar Corporation  
**EQUIPMENT** : mobile phone  
**BRAND NAME** : Avvio  
**MODEL NAME** : Avvio 515S  
**FCC ID** : WVBA515S  
**STANDARD** : FCC 47 CFR FCC Part 15 Subpart B  
**CLASSIFICATION** : Certification

The product was received on Mar. 07, 2012 and completely tested on Mar. 21, 2012. We, SPORTON INTERNATIONAL (KUNSHAN) INC., would like to declare that the tested sample has been evaluated in accordance with the procedures given in ANSI C63.4-2003 and shown the compliance with the applicable technical standards.

The test results in this report apply exclusively to the tested model / sample. Without written approval of SPORTON INTERNATIONAL (KUNSHAN) INC., the test report shall not be reproduced except in full.

Reviewed by:



Jones Tsai / Manager



**SPORTON INTERNATIONAL (KUNSHAN) INC.**  
**No. 3-2, PingXiang Road, Kunshan, Jiangsu Province, P.R.C.**



## TABLE OF CONTENTS

REVISION HISTORY..... 3

SUMMARY OF TEST RESULT ..... 4

1. GENERAL DESCRIPTION ..... 5

    1.1. Applicant..... 5

    1.2. Manufacturer ..... 5

    1.3. Feature of Equipment Under Test..... 5

    1.4. Test Site ..... 6

    1.5. Applied Standards ..... 6

    1.6. Ancillary Equipment List..... 6

2. TEST CONFIGURATION OF EQUIPMENT UNDER TEST ..... 6

    2.1. Test Mode ..... 7

    2.2. Connection Diagram of Test System ..... 9

    2.3. Test Software ..... 10

3. TEST RESULT ..... 11

    3.1. Test of AC Conducted Emission Measurement ..... 11

    3.2. Test of Radiated Emission Measurement ..... 15

4. LIST OF MEASURING EQUIPMENT ..... 20

5. UNCERTAINTY OF EVALUATION ..... 21

APPENDIX A. PHOTOGRAPHS OF EUT

APPENDIX B. SETUP PHOTOGRAPHS





### SUMMARY OF TEST RESULT

Report Section	FCC Rule	Description	Limit	Result	Remark
3.1	15.107	AC Conducted Emission	< 15.107 limits	PASS	Under limit 13.00 dB at 1.59 MHz
3.2	15.109	Radiated Emission	< 15.109 limits	PASS	Under limit 4.23 dB at 711.60 MHz for peak Under limit 6.83 dB at 59.97 MHz for Quasi-Peak



## 1. General Description

### 1.1. Applicant

**Brightstar Corporation**  
9725 NW 117th Ave., Miami, Florida, United States

### 1.2. Manufacturer

**Skycom Telecommunications Co Limited**  
Room 604, East Block, Shengtang Building, Futian District, Shenzhen, China

### 1.3. Feature of Equipment Under Test

Product Feature & Specification	
Equipment	mobile phone
Brand Name	Avvio
Model Name	Avvio 515S
FCC ID	WVBA515S
Tx Frequency Range	GSM850 : 824 MHz ~ 849 MHz GSM1900 : 1850 MHz ~ 1910 MHz Bluetooth : 2400 MHz ~ 2483.5 MHz
Rx Frequency Range	GSM850 : 869 MHz ~ 894 MHz GSM1900 : 1930 MHz ~ 1990 MHz Bluetooth : 2400 MHz ~ 2483.5 MHz
Antenna Type	WWAN: Fixed Internal Antenna Bluetooth: Dipole Antenna
HW Version	X321 V0.2
SW Version	X321_7D_BT_FM_NMI60X_6432_LCD220X176_TC_ WQCIF_AVVIO515S_V07_120305
Type of Modulation	GSM / GPRS : GMSK Bluetooth (1Mbps) : GFSK Bluetooth EDR (2Mbps) : $\pi/4$ -DQPSK Bluetooth EDR (3Mbps) : 8-DPSK
EUT Stage	Identical Prototype

**Remark:** The above EUT's information was declared by manufacturer. Please refer to the specifications or user's manual for more detailed description.

## 1.4. Test Site

<b>Test Site</b>	SPORTON INTERNATIONAL (KUNSHAN) INC.		
<b>Test Site Location</b>	No. 3-2, PingXiang Road, Kunshan, Jiangsu Province, P.R.C. TEL: +86-0512-5790-0158 FAX: +86-0512-5790-0958		
<b>Test Site No.</b>	<b>Sporton Site No.</b>		<b>FCC/IC Registration No.</b>
	CO01-KS	03CH01-KS	149928/4086E-1

## 1.5. Applied Standards

According to the specifications of the manufacturer, the EUT must comply with the requirements of the following standards:

- FCC 47 CFR FCC Part 15 Subpart B
- ANSI C63.4-2003

**Remark:** All test items were verified and recorded according to the standards and without any deviation during the test.

## 1.6. Ancillary Equipment List

Item	Equipment	Trade Name	Model Name	FCC ID	Data Cable	Power Cord
1.	System Simulator	R&S	CMU 200	N/A	N/A	Unshielded, 1.8 m
2.	Signal Generator	R&S	CMU 200	N/A	N/A	Unshielded, 1.8 m
3.	PC	R&S	MT380	FCC DoC	N/A	Unshielded, 1.8 m
4.	PC	DELL	MT320	FCC DoC	N/A	Unshielded, 1.8 m
5.	Monitor	DELL	E1910Hc	FCC DoC	Shielded, 1.2 m	Unshielded, 1.8 m
6.	Printer	HP	Laser Jet 1018	FCC DoC	Shielded, 1.8 m	Unshielded, 1.8 m
7.	Bluetooth Earphone	Nokia	BH-102	PYAHS-107W	N/A	N/A
8.	Bluetooth Earphone	Nokia	BH-106	QTLBH-106	N/A	N/A
9.	(USB) Keyboard	DELL	L100	FCC DoC	Shielded, 1.8 m with Core	N/A
10.	(USB) Keyboard	DELL	SK-8115	FCC DoC	Shielded, 1.8 m with Core	N/A
11.	(USB) Mouse	DELL	MO56UC	FCC DoC	Shielded, 1.8 m	N/A
12.	(USB) Mouse	DELL	N231	FCC DoC	Shielded, 1.8 m	N/A
13.	iPod	Apple	A1199	FCC DoC	Shielded, 1.2 m	N/A

## 2. Test Configuration of Equipment Under Test

### 2.1. Test Mode

The EUT has been associated with peripherals pursuant to ANSI C63.4-2003 and configuration operated in a manner tended to maximize its emission characteristics in a typical application.

Frequency range investigated: conduction (150 KHz to 30 MHz), radiation (30MHz to the 5th harmonic of the highest fundamental frequency or to 40 GHz, whichever is lower).

The following tables are showing the test modes as the worst cases and recorded in this report.

Item	EUT Configuration	Test Condition		
		EMI AC	EMI RE<1G	EMI RE≥1G
1.	Operating Mode (EUT with earphone)	Note 1	<input checked="" type="checkbox"/>	Note 1
2.	Charging Mode (EUT with adapter)	<input checked="" type="checkbox"/>	<input checked="" type="checkbox"/>	Note 1
3.	Data application transferred mode (EUT with PC)	<input checked="" type="checkbox"/>	<input checked="" type="checkbox"/>	<input checked="" type="checkbox"/>

**Abbreviations:**

- EMI AC: AC conducted emissions
- EMI RE ≥ 1G: EUT radiated emissions ≥ 1GHz
- EMI RE < 1G: EUT radiated emissions < 1GHz

**Note 1:** Testing for this mode is not required or not the worst case.

Test Items	EUT Configure Mode	Function Type
AC Conducted Emission	2/3	Mode 1: GSM 850 Idle + Bluetooth Idle + Adapter + Camera Mode 2: GSM 1900 Idle + Bluetooth Idle + Adapter + MP3 Mode 3: <b>GSM 1900 Idle + Bluetooth Idle + USB Cable (Data Link with PC)</b>
Radiated Emissions < 1GHz	1/2/3	Mode 1: GSM 850 Idle + Bluetooth Idle + Adapter + Camera Mode 2: GSM 1900 Idle + Bluetooth Idle + Adapter + MP3 Mode 3: GSM 850 Idle + Bluetooth Idle + Earphone + FM Rx Mode 4: <b>GSM 1900 Idle + Bluetooth Idle + USB Cable (Data Link with PC)</b>
Radiated Emissions ≥ 1GHz	3	Mode 1: GSM 1900 Idle + Bluetooth Idle + USB Cable (Data Link with PC)
<b>Remark:</b> <ol style="list-style-type: none"> <li>The worst case of AC is mode 3; only the test data of this mode was reported.</li> <li>The worst case of RE &lt; 1G is mode 4; only the test data of this mode was reported.</li> <li>Data Link with PC means data application transferred mode between EUT and PC.</li> </ol>		



## 2.2. Connection Diagram of Test System

### <EUT with Adapter Mode>

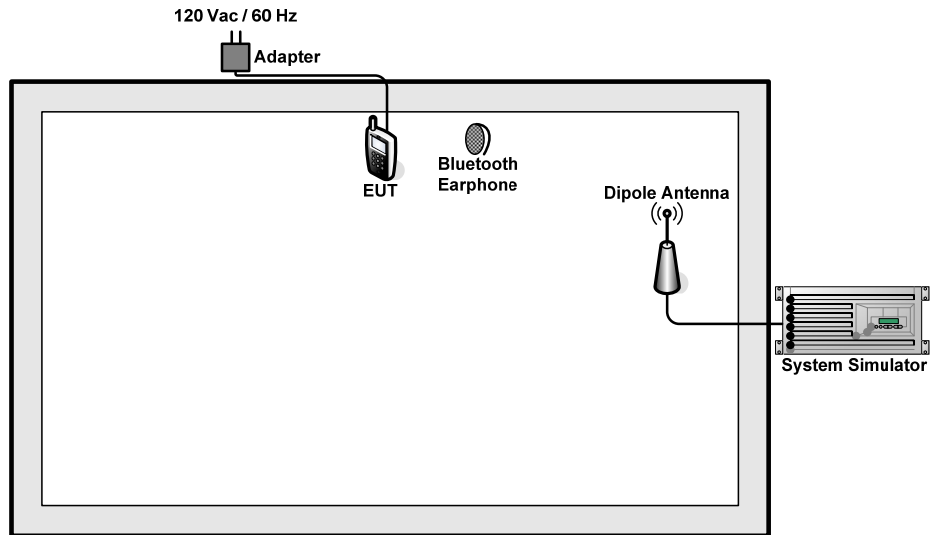

### <EUT with Earphone Mode>

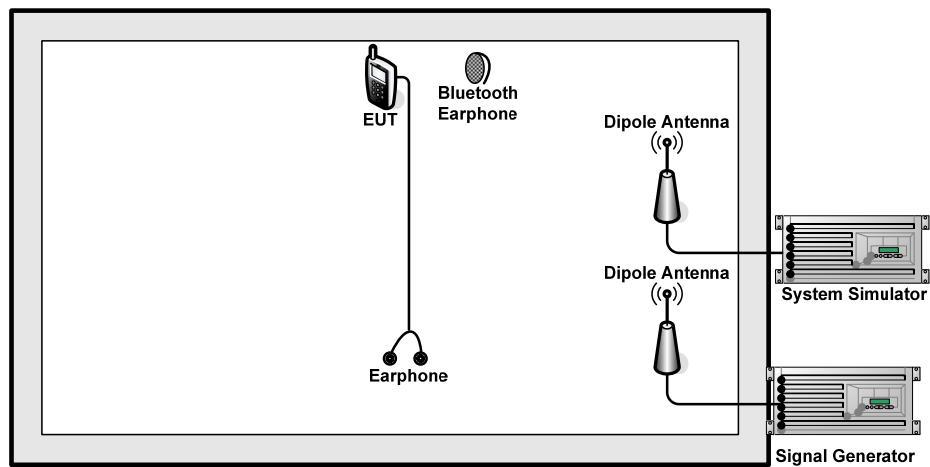

<EUT with USB Cable (Data Link with PC) Mode>

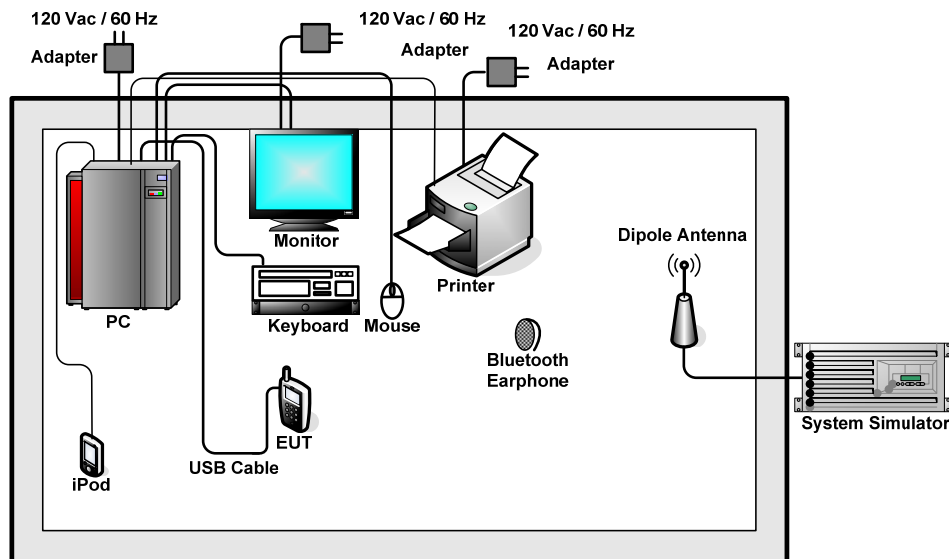

## 2.3. Test Software

The EUT was in GSM idle mode during the testing. The EUT was synchronized to the BCCH, and is in continuous receiving mode by setting system simulator's paging reorganization.

At the same time, the EUT was attached to the Bluetooth earphone, and the following programs installed in the EUT were programmed during the test.

1. Execute the program, "Winthrax", installed in PC for active sync files transfer with EUT via USB cable / iPod.
2. Execute "Music Player" to play MP3 file.
3. Turn on camera to capture images.
4. Turn on FM function to keep EUT receiving signals continuously in FM Rx mode.
5. Keep the EUT transmitting and receiving signals continuously from system simulator.

### 3. Test Result

#### 3.1. Test of AC Conducted Emission Measurement

##### 3.1.1 Limits of AC Conducted Emission

For equipment that is designed to be connected to the public utility (AC) power line, the radio frequency voltage that is conducted back onto the AC power line on any frequency or frequencies within the band 150 KHz to 30 MHz shall not exceed the limits in the following table.

Frequency of emission (MHz)	Conducted limit (dBuV)	
	Quasi-peak	Average
0.15-0.5	66 to 56*	56 to 46*
0.5-5	56	46
5-30	60	50

\*Decreases with the logarithm of the frequency.

##### 3.1.2 Measuring Instruments

See list of measuring instruments of this test report.

##### 3.1.3 Test Procedure

1. The EUT was placed 0.4 meter from the conducting wall of the shielding room was kept at least 80 centimeters from any other grounded conducting surface.
2. The EUT link with PC, connect PC to the power mains through a line impedance stabilization network (LISN).
3. All the support units are connecting to the other LISN.
4. The LISN provides 50 ohm coupling impedance for the measuring instrument.
5. The FCC states that a 50 ohm, 50 microhenry LISN should be used.
6. Both sides of AC line were checked for maximum conducted interference.
7. The frequency range from 150 KHz to 30 MHz was searched.
8. Set the test-receiver system to Peak Detect Function and specified bandwidth with Maximum Hold Mode.

### 3.1.4 Test Setup

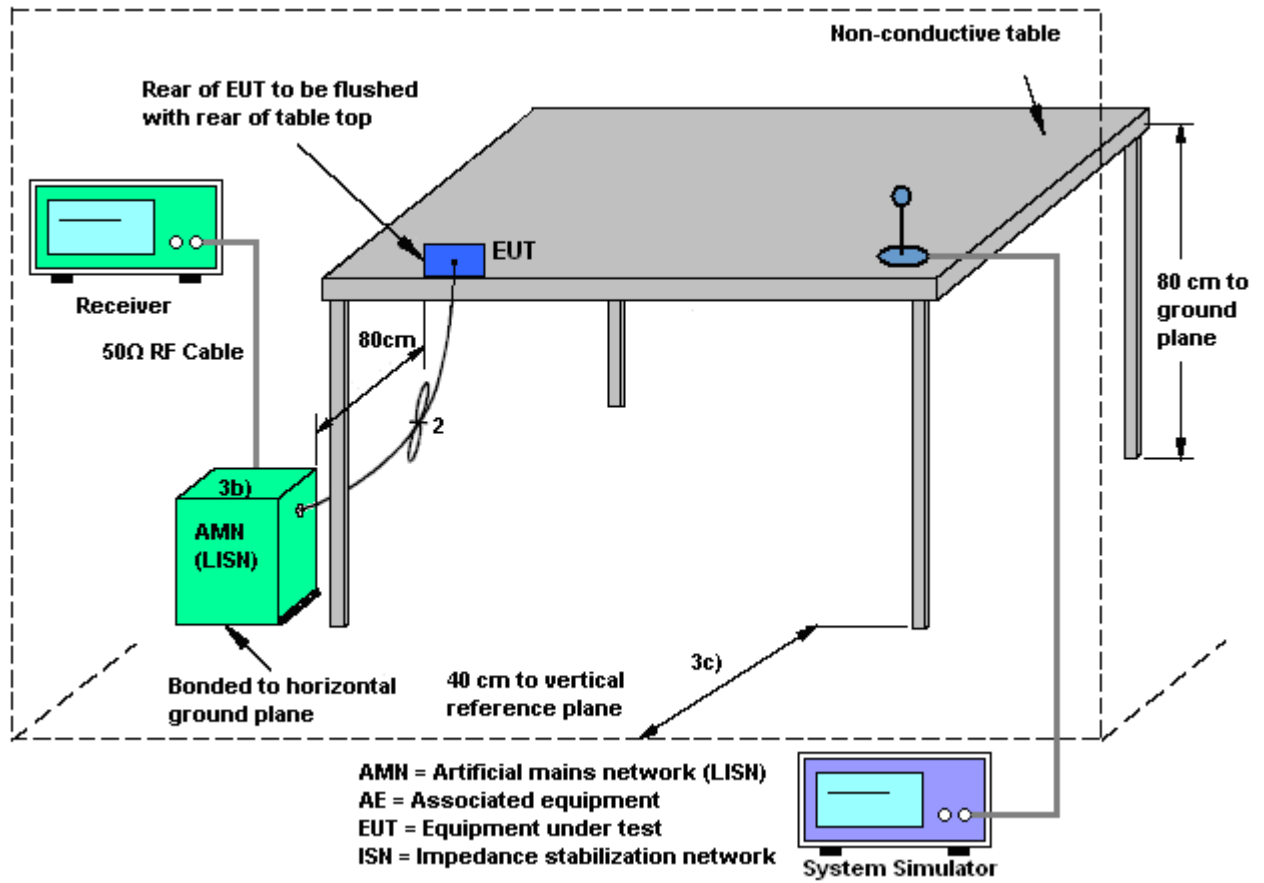

3.1.5 Test Result of AC Conducted Emission

Test Mode :	Mode 3	Temperature :	19~20°C
Test Engineer :	Tom Wang	Relative Humidity :	39~40%
Test Voltage :	120Vac / 60Hz	Phase :	Line
Function Type :	GSM 1900 Idle + Bluetooth Idle + USB Cable (Data Link with PC)		
Remark :	All emissions not reported here are more than 10 dB below the prescribed limit.		

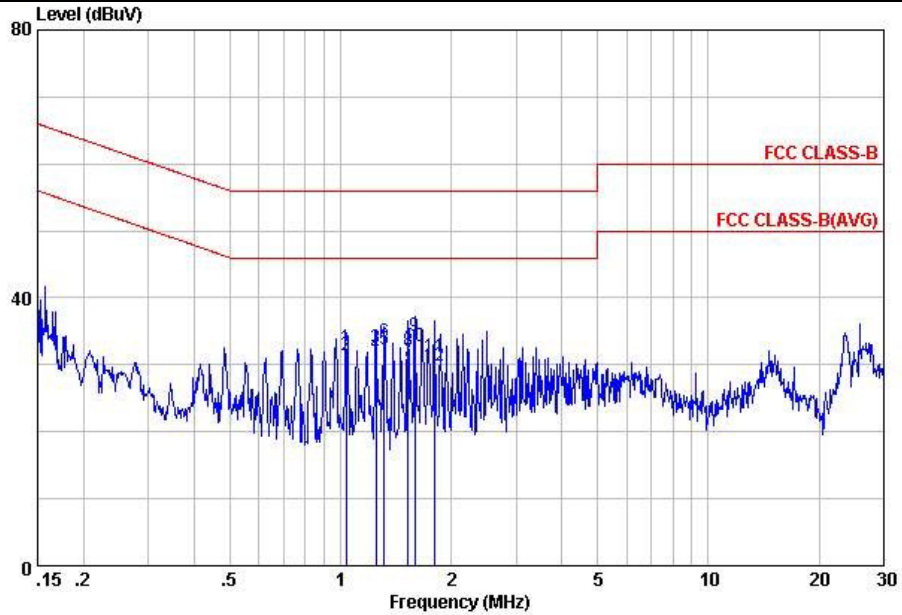

Site : C001-KS  
 Condition: FCC CLASS-B LISN-100807 LINE  
 Project : (FC) 192301-01  
 mode : Mode 3  
 IMEI : IMEI:354748043212048

	Freq	Level	Over Limit	Limit Line	Read Level	LISN Factor	Cable Loss	Remark
	MHz	dBuV	dB	dBuV	dBuV	dB	dB	
1	1.04	32.47	-23.53	56.00	22.30	-0.10	10.27	QP
2	1.04	31.47	-14.53	46.00	21.30	-0.10	10.27	Average
3	1.25	32.58	-23.42	56.00	22.40	-0.10	10.28	QP
4	1.25	31.58	-14.42	46.00	21.40	-0.10	10.28	Average
5	1.32	32.38	-13.62	46.00	22.19	-0.10	10.29	Average
6	1.32	33.38	-22.62	56.00	23.19	-0.10	10.29	QP
7	1.53	30.50	-15.50	46.00	20.31	-0.11	10.30	Average
8	1.53	32.00	-24.00	56.00	21.81	-0.11	10.30	QP
9	1.59	34.30	-21.70	56.00	24.10	-0.11	10.31	QP
10	1.59	32.70	-13.30	46.00	22.50	-0.11	10.31	Average
11	1.80	31.21	-24.79	56.00	21.00	-0.11	10.32	QP
12	1.80	29.91	-16.09	46.00	19.70	-0.11	10.32	Average



Test Mode :	Mode 3	Temperature :	19~20°C
Test Engineer :	Tom Wang	Relative Humidity :	39~40%
Test Voltage :	120Vac / 60Hz	Phase :	Neutral
Function Type :	GSM 1900 Idle + Bluetooth Idle + USB Cable (Data Link with PC)		
Remark :	All emissions not reported here are more than 10 dB below the prescribed limit.		

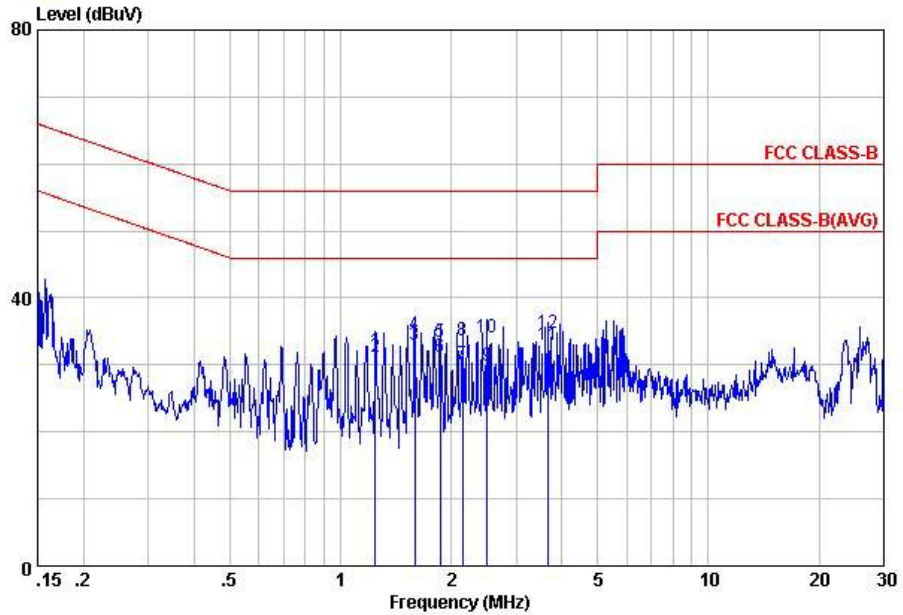

Site : C001-KS  
 Condition: FCC CLASS-B LISN-100807 NEUTRAL  
 Project : (FC) 192301-01  
 mode : Mode 3  
 IMEI : IMEI:354748043212048

	Freq	Level	Over	Limit	Read	LISN	Cable	Remark
	MHz	dBuV	dB	dBuV	dBuV	dB	dB	
1	1.24	32.09	-23.91	56.00	21.90	-0.09	10.28	QP
2	1.24	31.19	-14.81	46.00	21.00	-0.09	10.28	Average
3	1.59	33.00	-13.00	46.00	22.79	-0.10	10.31	Average
4	1.59	34.50	-21.50	56.00	24.29	-0.10	10.31	QP
5	1.87	33.41	-22.59	56.00	23.20	-0.11	10.32	QP
6	1.87	31.21	-14.79	46.00	21.00	-0.11	10.32	Average
7	2.14	30.03	-15.97	46.00	19.80	-0.11	10.34	Average
8	2.14	33.73	-22.27	56.00	23.50	-0.11	10.34	QP
9	2.50	29.84	-16.16	46.00	19.60	-0.11	10.35	Average
10	2.50	34.04	-21.96	56.00	23.80	-0.11	10.35	QP
11	3.68	32.96	-13.04	46.00	22.70	-0.12	10.38	Average
12	3.68	34.66	-21.34	56.00	24.40	-0.12	10.38	QP

## 3.2. Test of Radiated Emission Measurement

### 3.2.1. Limit of Radiated Emission

The emissions from an intentional radiator shall not exceed the field strength levels specified in the following table:

Frequency (MHz)	Field Strength (microvolts/meter)	Measurement Distance (meters)
0.009 – 0.490	2400/F(KHz)	300
0.490 – 1.705	24000/F(KHz)	30
1.705 – 30.0	30	30
30 – 88	100	3
88 – 216	150	3
216 - 960	200	3
Above 960	500	3

### 3.2.2. Measuring Instruments

See list of measuring instruments of this test report.



### **3.2.3. Test Procedures**

1. The EUT was placed on a turntable with 0.8 meter above ground.
2. The EUT was set 3 meters from the interference receiving antenna, which was mounted on the top of a variable height antenna tower.
3. The table was rotated 360 degrees to determine the position of the highest radiation.
4. The antenna is a Bi-Log antenna and its height is adjusted between one meter and four meters above ground to find the maximum value of the field strength for both horizontal polarization and vertical polarization of the antenna.
5. For each suspected emission, the EUT was arranged to its worst case and then tune the antenna tower (from 1 m to 4 m) and turntable (from 0 degree to 360 degrees) to find the maximum reading.
6. Set the test-receiver system to Peak Detect Function and specified bandwidth with Maximum Hold Mode.
7. If the emission level of the EUT in peak mode was 3 dB lower than the limit specified, then testing will be stopped and peak values of EUT will be reported, otherwise, the emissions will be repeated one by one using the quasi-peak method and reported
8. Emission level (dBuV/m) = 20 log Emission level (uV/m)
9. Corrected Reading: Antenna Factor + Cable Loss + Read Level - Preamp Factor = Level



### 3.2.4. Test Setup of Radiated Emission

For radiated emissions below 30MHz

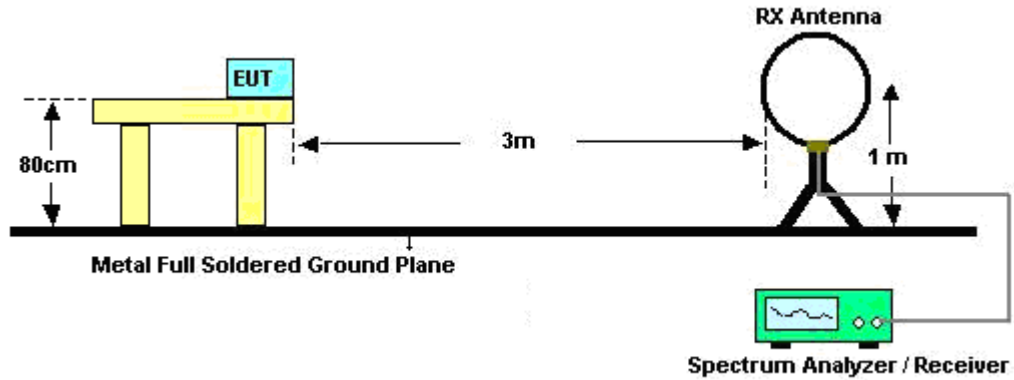

For radiated emissions above 30MHz

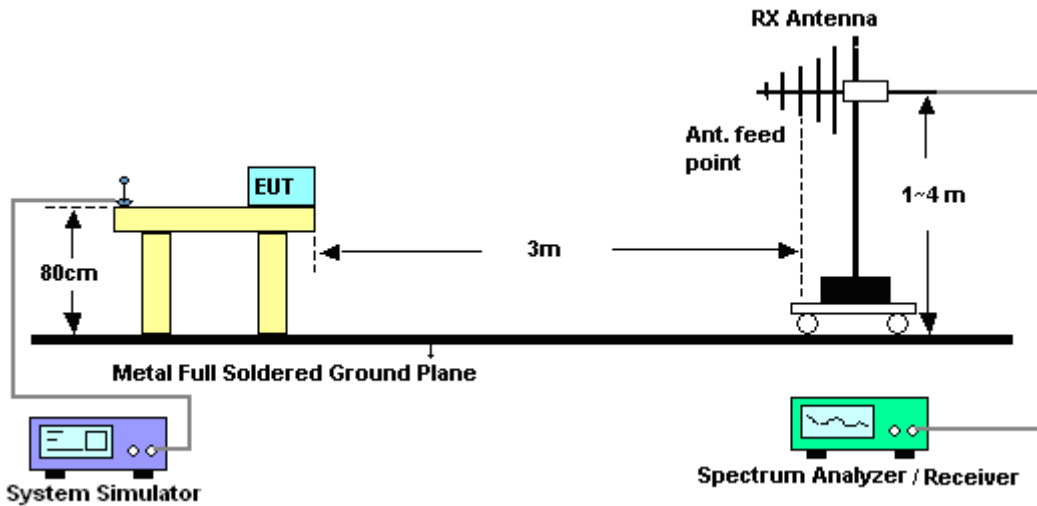

### 3.2.5. Test Results of Radiated Emissions (9 kHz ~ 30 MHz)

The low frequency, which started from 9 KHz to 30MHz, was pre-scanned and the result which was 20dB lower than the limit line per 15.31(o) was not reported.

3.2.6. Test Result of Radiated Emission

Test Mode :	Mode 4	Temperature :	20~21°C
Test Engineer :	Jack Li	Relative Humidity :	42~43%
Test Distance :	3m	Polarization :	Horizontal
Function Type :	GSM 1900 Idle + Bluetooth Idle + USB Cable (Data Link with PC)		

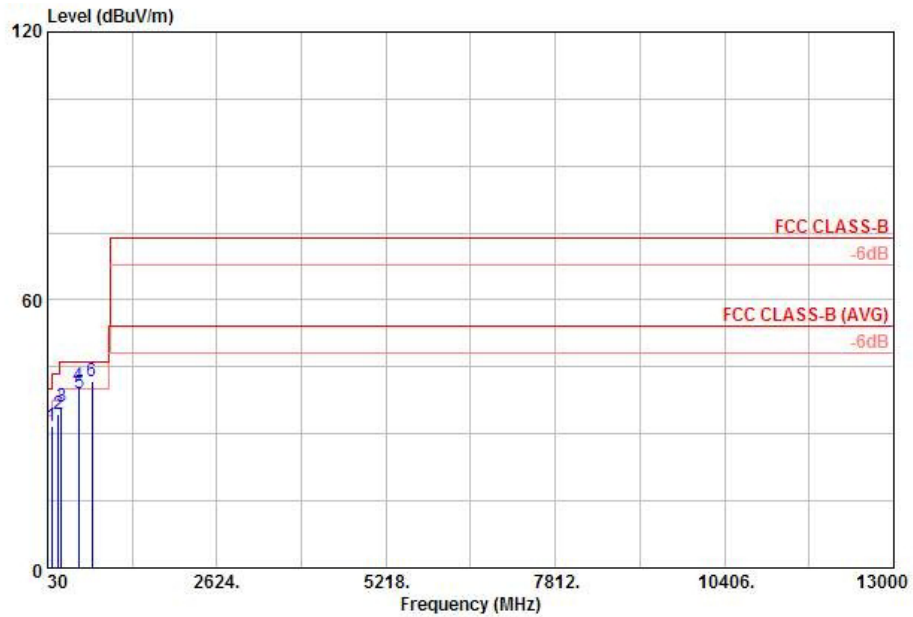

Site : 03CH01-KS  
 Condition: FCC CLASS-B 3m LF\_ANT\_100803 HORIZONTAL  
 Project : (FC) 192301-01  
 Mode : mode 4

	Freq	Level	Over	Limit	ReadAntenna	Cable	Preamp	Ant	Table	Remark	
	MHz	dBuV/m	dB	dBuV/m	dBuV	dB/m	dB	dB	cm	deg	
1	95.88	31.88	-11.62	43.50	51.54	9.91	0.40	29.97	---	---	Peak
2	192.00	34.29	-9.21	43.50	55.08	8.59	0.58	29.96	---	---	Peak
3	240.06	36.19	-9.81	46.00	53.79	11.56	0.66	29.82	---	---	Peak
4 !	503.70	40.71	-5.29	46.00	52.22	17.26	0.96	29.73	---	---	Peak
5	515.60	39.00	-7.00	46.00	50.20	17.55	0.97	29.72	---	---	Peak
6 !	711.60	41.77	-4.23	46.00	50.91	19.41	1.14	29.69	200	0	Peak



Test Mode :	Mode 4	Temperature :	20~21°C
Test Engineer :	Jack Li	Relative Humidity :	42~43%
Test Distance :	3m	Polarization :	Vertical
Function Type :	GSM 1900 Idle + Bluetooth Idle + USB Cable (Data Link with PC)		

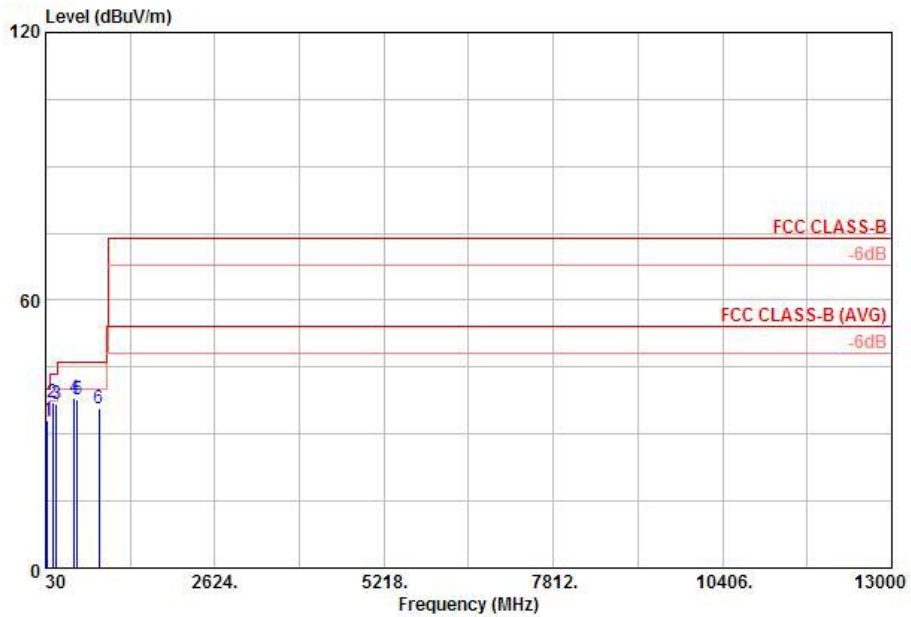

Site : 03CH01-KS  
 Condition: FCC CLASS-B 3m LF\_ANT\_100803 VERTICAL  
 Project : (FC) 192301-01  
 Mode : mode 4

	Freq	Level	Over	Limit	ReadAntenna	Cable	Preamp	Ant	Table	
	MHz	dBuV/m	Limit	Line	Level	Loss	Factor	Pos	Pos	Remark
			dB	dBuV/m	dBuV	dB/m	dB	dB	cm	deg
1	59.97	33.17	-6.83	40.00	57.70	5.30	0.31	30.14	198	0 QP
2	143.94	37.02	-6.48	43.50	55.96	10.55	0.50	29.99	---	Peak
3	192.00	36.81	-6.69	43.50	57.60	8.59	0.58	29.96	---	Peak
4	474.30	38.05	-7.95	46.00	50.16	16.72	0.93	29.76	---	Peak
5	515.60	37.86	-8.14	46.00	49.06	17.55	0.97	29.72	---	Peak
6	850.20	35.67	-10.33	46.00	43.54	20.51	1.28	29.66	---	Peak

## 4. List of Measuring Equipment

Instrument	Manufacturer	Model No.	Serial No.	Characteristics	Calibration Date	Test Date	Due Date	Remark
EMI Receiver	R&S	ESCI7	100768	9kHz~7GHz	Jun. 02, 2011	Mar. 15, 2012	Jun. 01, 2012	Conduction (CO01-KS)
LISN	MessTec	AN3016	60103	9kHz~30MHz	Dec. 30, 2011	Mar. 15, 2012	Dec. 29, 2012	Conduction (CO01-KS)
LISN	MessTec	AN3016	60105	9kHz~30MHz	Dec. 30, 2011	Mar. 15, 2012	Dec. 29, 2012	Conduction (CO01-KS)
AC Power Source	Chroma	61602	ABP0000008 11	N/A	Nov. 16, 2011	Mar. 15, 2012	Nov. 15, 2012	Conduction (CO01-KS)
System Simulator	R&S	CMU200	837587/066	2G Full-Band	Dec. 30, 2011	Mar. 15, 2012	Dec. 29, 2012	Conduction (CO01-KS)
EMI Test Receiver	R&S	ESCI	100534	9kHz~3GHz	Nov. 09, 2011	Mar. 21, 2012	Nov. 08, 2012	Radiation (03CH01-KS)
Spectrum Analyzer	R&S	FSP40	100319	9kHz~40GHz	Dec. 30, 2011	Mar. 21, 2012	Dec. 29, 2012	Radiation (03CH01-KS)
Bilog Antenna	SCHAFFNER	CBL6112D	23182	25MHz~2GHz	Dec. 08, 2011	Mar. 21, 2012	Dec. 07, 2012	Radiation (03CH01-KS)
Loop Antenna	R&S	HFH2-Z2	860004/00	9 kHz~30 MHz	Jul. 28, 2011	Mar. 21, 2012	Jul. 27, 2012	Radiation (03CH01-KS)
Double Ridge Horn Antenna	EMCO	3117	00075959	1GHz~18GHz	Jan. 06, 2012	Mar. 21, 2012	Jan. 05, 2013	Radiation (03CH01-KS)
Amplifier	Wireless	FPA-6592G	060007	30MHz~2GHz	Dec. 30, 2011	Mar. 21, 2012	Dec. 29, 2012	Radiation (03CH01-KS)
Amplifier	Agilent	8449B	3008A02370	1GHz~26.5GHz	Dec. 30, 2011	Mar. 21, 2012	Dec. 29, 2012	Radiation (03CH01-KS)
Active Horn Antenna	com-power	AHA-118	701023	1GHz~18GHz	Nov. 07, 2011	Mar. 21, 2012	Nov. 06, 2012	Radiation (03CH01-KS)
Signal Generator	R&S	SMR40	100455	10GHz~40GHz	Dec. 30, 2011	Mar. 21, 2012	Dec. 29, 2012	Radiation (03CH01-KS)
SHE-EHF Horn	Schwarzbeck	BBHA9170	BBHA170249	15GHz~40GHz	Oct. 11, 2011	Mar. 21, 2012	Oct. 10, 2012	Radiation (03CH01-KS)
System Simulator	R&S	CMU200	837587/066	2G Full-Band	Dec. 30, 2011	Mar. 21, 2012	Dec. 29, 2012	Radiation (03CH01-KS)

## 5. Uncertainty of Evaluation

### Uncertainty of Conducted Emission Measurement (150 KHz ~ 30 MHz)

Contribution	Uncertainty of $X_i$		$u(X_i)$
	dB	Probability Distribution	
Receiver Reading	0.10	Normal (k=2)	0.05
Cable Loss	0.10	Normal (k=2)	0.05
AMN Insertion Loss	2.50	Rectangular	0.63
Receiver Specification	1.50	Rectangular	0.43
Site Imperfection	1.39	Rectangular	0.80
Mismatch	+0.34 / -0.35	U-Shape	0.24
<b>Combined Standard Uncertainty <math>U_c(y)</math></b>	<b>1.13</b>		
<b>Measuring Uncertainty for a Level of Confidence of 95% (<math>U = 2U_c(y)</math>)</b>	<b>2.26</b>		

### Uncertainty of Radiated Emission Measurement (30 MHz ~ 1000 MHz)

Contribution	Uncertainty of $X_i$		$u(X_i)$
	dB	Probability Distribution	
Receiver Reading	0.41	Normal (k=2)	0.21
Antenna Factor Calibration	0.83	Normal (k=2)	0.42
Cable Loss Calibration	0.25	Normal (k=2)	0.13
Pre-Amplifier Gain Calibration	0.27	Normal (k=2)	0.14
RCV/SPA Specification	2.50	Rectangular	0.72
Antenna Factor Interpolation for Frequency	1.00	Rectangular	0.29
Site Imperfection	1.43	Rectangular	0.83
Mismatch	+0.39 / -0.41	U-Shape	0.28
<b>Combined Standard Uncertainty <math>U_c(y)</math></b>	<b>1.27</b>		
<b>Measuring Uncertainty for a Level of Confidence of 95% (<math>U = 2U_c(y)</math>)</b>	<b>2.54</b>		

**Uncertainty of Radiated Emission Measurement (1 GHz ~ 40 GHz)**

Contribution	Uncertainty of $X_i$		$u(X_i)$	$C_i$	$C_i * u(X_i)$
	dB	Probability Distribution			
Receiver Reading	$\pm 0.10$	Normal (k=2)	0.10	1	0.10
Antenna Factor Calibration	$\pm 1.70$	Normal (k=2)	0.85	1	0.85
Cable Loss Calibration	$\pm 0.50$	Normal (k=2)	0.25	1	0.25
Receiver Correction	$\pm 2.00$	Rectangular	1.15	1	1.15
Antenna Factor Directional	$\pm 1.50$	Rectangular	0.87	1	0.87
Site Imperfection	$\pm 2.80$	Triangular	1.14	1	1.14
Mismatch Receiver VSWR $\Gamma_1 = 0.197$ Antenna VSWR $\Gamma_2 = 0.194$ Uncertainty = $20\text{Log}(1-\Gamma_1*\Gamma_2)$	+0.34 / -0.35	U-Shape	0.244	1	0.244
<b>Combined Standard Uncertainty <math>U_c(y)</math></b>	<b>2.36</b>				
<b>Measuring Uncertainty for a Level of Confidence of 95% (<math>U = 2U_c(y)</math>)</b>	<b>4.72</b>				



## **Appendix A. Photographs of EUT**

Please refer to Sporton report number EP192301-01 as below.