

FCC Test Report

APPLICANT : Brightstar Corporation
EQUIPMENT : Mobile phone
BRAND NAME : Avvio
MODEL NAME : AVVIO 399S
FCC ID : WVBA399S
STANDARD : FCC 47 CFR FCC Part 15 Subpart B
CLASSIFICATION : Certification

The product was received on Feb. 17, 2012 and completely tested on Mar. 14, 2012. We, SPORTON INTERNATIONAL (KUNSHAN) INC., would like to declare that the tested sample has been evaluated in accordance with the procedures given in ANSI C63.4-2003 and shown the compliance with the applicable technical standards.

The test results in this report apply exclusively to the tested model / sample. Without written approval of SPORTON INTERNATIONAL (KUNSHAN) INC., the test report shall not be reproduced except in full.

Reviewed by:



Jones Tsai / Manager



SPORTON INTERNATIONAL (KUNSHAN) INC.
No. 3-2, PingXiang Road, Kunshan, Jiangsu Province, P.R.C.



TABLE OF CONTENTS

REVISION HISTORY..... 3

SUMMARY OF TEST RESULT 4

1. GENERAL DESCRIPTION 5

 1.1. Applicant..... 5

 1.2. Manufacturer 5

 1.3. Feature of Equipment Under Test..... 5

 1.4. Test Site 6

 1.5. Applied Standards 6

 1.6. Ancillary Equipment List..... 7

2. TEST CONFIGURATION OF EQUIPMENT UNDER TEST 7

 2.1. Test Mode 8

 2.2. Connection Diagram of Test System 10

 2.3. Test Software 12

3. TEST RESULT 13

 3.1. Test of AC Conducted Emission Measurement 13

 3.2. Test of Radiated Emission Measurement 17

4. LIST OF MEASURING EQUIPMENT 22

5. UNCERTAINTY OF EVALUATION 23

APPENDIX A. PHOTOGRAPHS OF EUT

APPENDIX B. SETUP PHOTOGRAPHS



SUMMARY OF TEST RESULT

Report Section	FCC Rule	Description	Limit	Result	Remark
3.1	15.107	AC Conducted Emission	< 15.107 limits	PASS	Under limit 10.05 dB at 0.19 MHz
3.2	15.109	Radiated Emission	< 15.109 limits	PASS	Under limit 3.20 dB at 371.40 MHz for peak Under limit 1.52 dB at 30.00 MHz for Quasi-Peak

1. General Description

1.1. Applicant

Brightstar Corporation
 9725 NW 117th Ave., Miami, Florida, United States

1.2. Manufacturer

Lenovo Mobile Internet and Digital Home
 East 5/F, Lenovo Research & Development Centre, Gaoxinnanyi Road, Hi-Tech Industrial Park, Shenzhen, Guangdong, China

1.3. Feature of Equipment Under Test

Product Feature & Specification	
Equipment	Mobile phone
Brand Name	Avvio
Model Name	AVVIO 399S
FCC ID	WVBA399S
Tx Frequency Range	GSM850 : 824 MHz ~ 849 MHz GSM1900 : 1850 MHz ~ 1910 MHz Bluetooth : 2400 MHz ~ 2483.5 MHz
Rx Frequency Range	GSM850 : 869 MHz ~ 894 MHz GSM1900 : 1930 MHz ~ 1990 MHz Bluetooth : 2400 MHz ~ 2483.5 MHz
Antenna Type	WWAN : Fixed Internal Antenna Bluetooth : Dipole Antenna
HW Version	PCB version 1.2
SW Version	T22A_LX_S12_BRAZIL_EP_V0_0_21(20120220).
Type of Modulation	GSM/ GPRS: GMSK Bluetooth (1Mbps) : GFSK Bluetooth EDR (2Mbps) : $\pi/4$ -DQPSK Bluetooth EDR (3Mbps) : 8-DPSK
EUT Stage	Production Unit

Remark: The above EUT's information was declared by manufacturer. Please refer to the specifications or user's manual for more detailed description.

1.4. Test Site

Test Site	SPORTON INTERNATIONAL (SHENZHEN) INC.	
Test Site Location	No. 101, Complex Building C, Guanglong Village, Xili Town, Nanshan District, Shenzhen, Guangdong, P.R.C. TEL: +86-755-8637-9589 FAX: +86-755-8637-9595	
Test Site No.	Sporton Site No. : CO01-SZ	

Test Site	SPORTON INTERNATIONAL (KUNSHAN) INC.	
Test Site Location	No. 3-2, PingXiang Road, Kunshan, Jiangsu Province, P.R.C. TEL: +86-0512-5790-0158 FAX: +86-0512-5790-0958	
Test Site No.	Sporton Site No.	FCC/IC Registration No.
	03CH01-KS	149928/4086E-1

1.5. Applied Standards

According to the specifications of the manufacturer, the EUT must comply with the requirements of the following standards:

- FCC 47 CFR FCC Part 15 Subpart B
- ANSI C63.4-2003

Remark: All test items were verified and recorded according to the standards and without any deviation during the test.

1.6. Ancillary Equipment List

Item	Equipment	Trade Name	Model Name	FCC ID	Data Cable	Power Cord
1.	System Simulator	R&S	CMU 200	N/A	N/A	Unshielded, 1.8 m
2.	System Simulator	Agilent	E5515C	N/A	N/A	Unshielded, 1.8 m
3.	Singal Generator	R&S	CMU 200	N/A	N/A	Unshielded, 1.8 m
4.	PC	DELL	MT380	FCC DoC	N/A	Unshielded, 1.8 m
5.	Monitor	DELL	E1910Hc	FCC DoC	Shielded, 1.2 m	Unshielded, 1.8 m
6.	Monitor	DELL	1707FPt	FCC DoC	Shielded, 1.2 m	Unshielded, 1.8 m
7.	Printer	HP	Laser Jet 1018	FCC DoC	Shielded, 1.8 m	Unshielded, 1.8 m
8.	(USB) Keyboard	DELL	SK-8115	FCC DoC	Shielded, 1.8 m	N/A
9.	(USB) Mouse	DELL	N231	FCC DoC	Shielded, 1.8 m	N/A
10.	iPod	Apple	A1199	FCC DoC	Shielded, 1.2 m	N/A
11.	iPod	Apple	MC525 ZP/A	FCC DoC	Shielded, 1.0 m	N/A
12.	Bluetooth Earphone	Nokia	BH-102	PYAHS-107W	N/A	N/A
13.	Bluetooth Earphone	Nokia	BH-108	N/A	N/A	N/A
14.	Earphone	Eimuse	E-500MV	FCC DoC	Shielded, 2.2 m	N/A
15.	Notebook	DELL	VOSTRO 1440	QDS-BRCM1051	N/A	AC I/P: Unshielded, 1.8 m DC O/P: Shielded, 1.8 m

2. Test Configuration of Equipment Under Test

2.1. Test Mode

The EUT has been associated with peripherals pursuant to ANSI C63.4-2003 and configuration operated in a manner tended to maximize its emission characteristics in a typical application.

Frequency range investigated: conduction (150 KHz to 30 MHz), radiation (30MHz to the 5th harmonic of the highest fundamental frequency or to 40 GHz, whichever is lower).

The following tables are showing the test modes as the worst cases and recorded in this report.

Item	EUT Configuration	Test Condition		
		EMI AC	EMI RE<1G	EMI RE≥1G
1.	Operating Mode (EUT with earphone)	Note 1	☒	Note 1
2.	Charging Mode (EUT with adapter)	☒	☒	Note 1
3.	Data application transferred mode (EUT with Notebook/PC)	☒	☒	☒

Abbreviations:

- EMI AC: AC conducted emissions
- EMI RE ≥ 1G: EUT radiated emissions ≥ 1GHz
- EMI RE < 1G: EUT radiated emissions < 1GHz

Note 1: Testing for this mode is not required or not the worst case.

Test Items	EUT Configure Mode	Function Type
AC Conducted Emission	2/3	Mode 1: GSM 850 Idle + Bluetooth Idle + Adapter + Camera Mode 2: GSM 1900 Idle + Bluetooth Idle + Adapter + MP3 Mode 3: GSM 1900 Idle + Bluetooth Idle + USB Cable (Data Link with Notebook)
Radiated Emissions < 1GHz	1/2/3	Mode 1: GSM 850 Idle + Bluetooth Idle + Adapter + Camera Mode 2: GSM 1900 Idle + Bluetooth Idle + Adapter + MP3 Mode 3: GSM 850 Idle + Bluetooth Idle + Earphone + FM Rx Mode 4: GSM 1900 Idle + Bluetooth Idle + USB Cable (Data Link with PC)
Radiated Emissions ≥ 1GHz	3	Mode 1: GSM 1900 Idle + Bluetooth Idle + USB Cable (Data Link with PC)
<p>Remark:</p> <ol style="list-style-type: none"> 1. The worst case of AC is mode 3; only the test data of this mode was reported. 2. The worst case of RE < 1G is mode 4; only the test data of this mode was reported. 3. Link with Notebook/PC means data application transferred mode between EUT and Notebook. 		

2.2. Connection Diagram of Test System

<EUT with Adapter Mode>

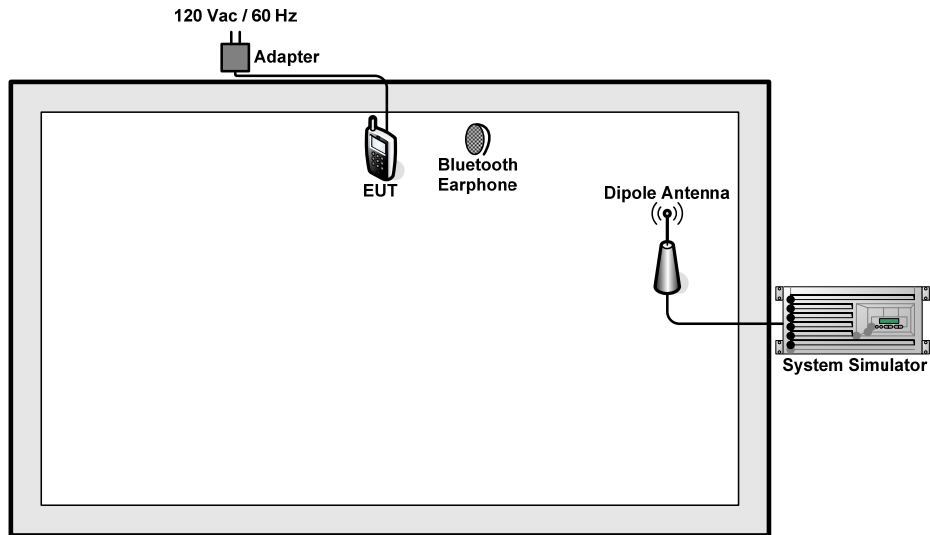

<EUT with Earphone Mode>

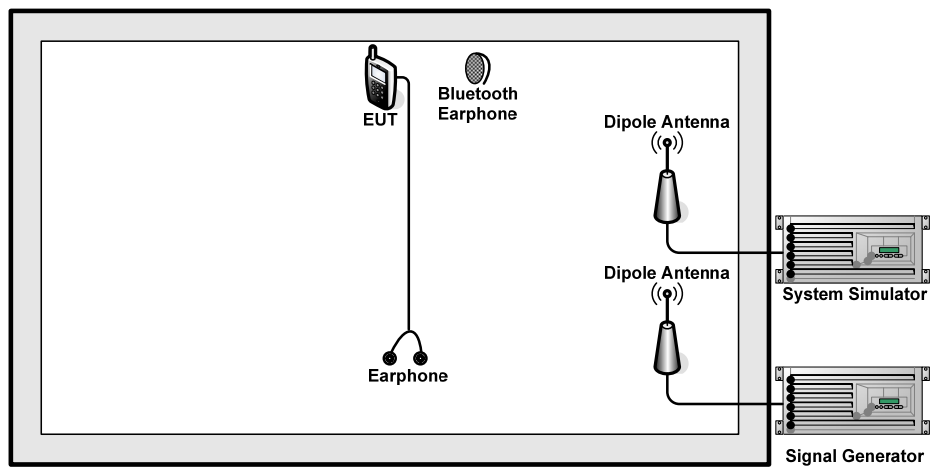

< EUT with USB Cable (Data Link with PC) Mode >

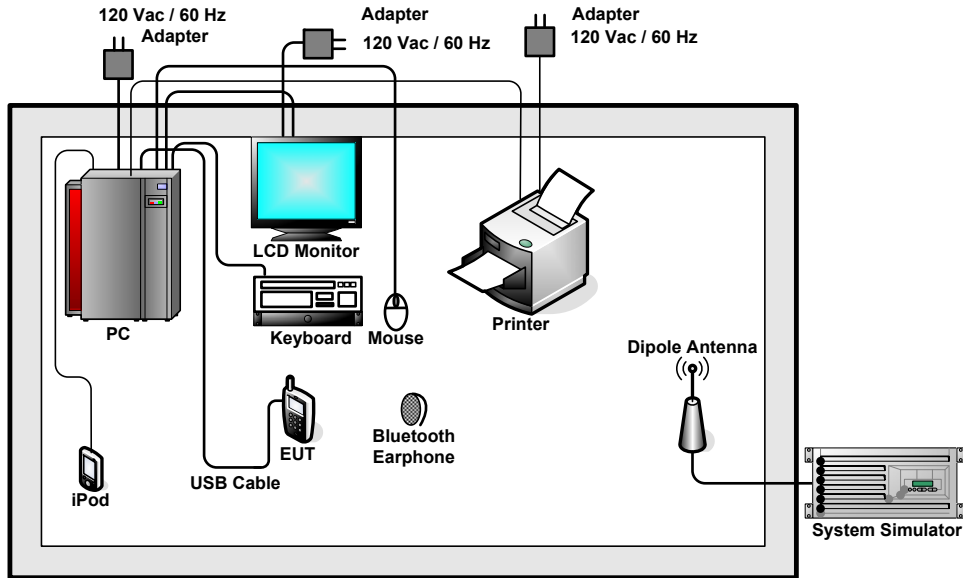

<EUT with USB Cable (Data Link with Notebook) Mode>

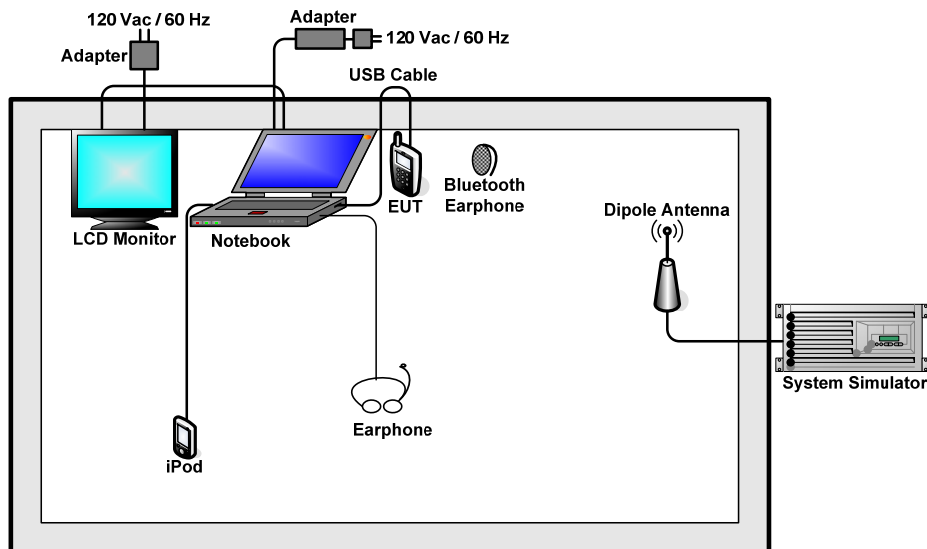



2.3. Test Software

The EUT was in GSM idle mode during the testing. The EUT was synchronized to the BCCH, and is in continuous receiving mode by setting system simulator's paging reorganization.

At the same time, the EUT was attached to the Bluetooth earphone, and the following programs installed in the EUT were programmed during the test.

1. Execute the program, "Winthrax", installed in notebook or PC for active sync files transfer with EUT via USB cable / iPod.
2. Execute "Music Player" to play MP3 file.
3. Turn on camera to capture images.
4. Turn on FM function to make the EUT receive signals from signal generator continuously.
5. Keep the EUT transmitting and receiving signals continuously from system simulator.

3. Test Result

3.1. Test of AC Conducted Emission Measurement

3.1.1 Limits of AC Conducted Emission

For equipment that is designed to be connected to the public utility (AC) power line, the radio frequency voltage that is conducted back onto the AC power line on any frequency or frequencies within the band 150 KHz to 30 MHz shall not exceed the limits in the following table.

Frequency of emission (MHz)	Conducted limit (dBuV)	
	Quasi-peak	Average
0.15-0.5	66 to 56*	56 to 46*
0.5-5	56	46
5-30	60	50

*Decreases with the logarithm of the frequency.

3.1.2 Measuring Instruments

See list of measuring instruments of this test report.

3.1.3 Test Procedure

1. The EUT was placed 0.4 meter from the conducting wall of the shielding room was kept at least 80 centimeters from any other grounded conducting surface.
2. The EUT link with PC/notebook, connect PC/notebook to the power mains through a line impedance stabilization network (LISN).
3. All the support units are connecting to the other LISN.
4. The LISN provides 50 ohm coupling impedance for the measuring instrument.
5. The FCC states that a 50 ohm, 50 microhenry LISN should be used.
6. Both sides of AC line were checked for maximum conducted interference.
7. The frequency range from 150 KHz to 30 MHz was searched.
8. Set the test-receiver system to Peak Detect Function and specified bandwidth with Maximum Hold Mode.

3.1.4 Test Setup

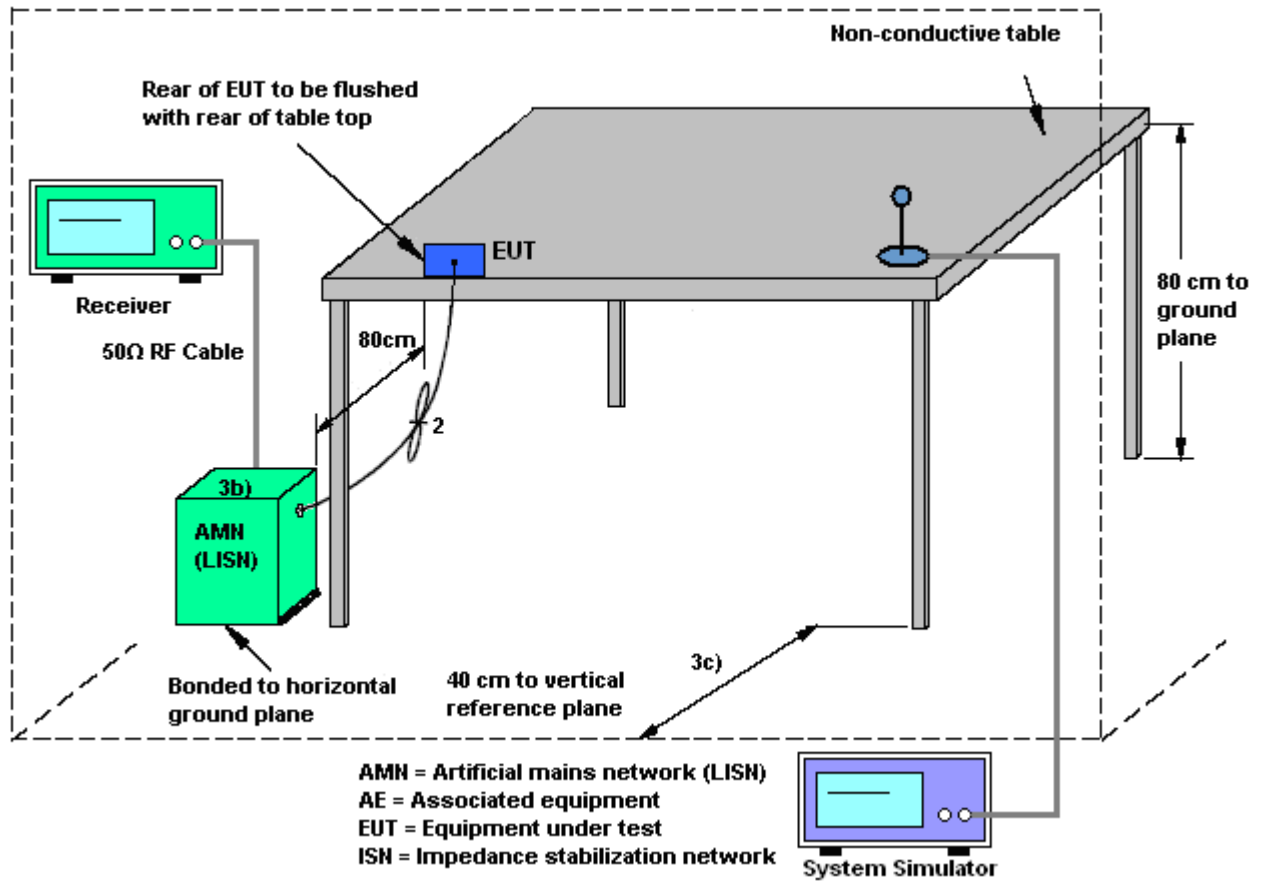



3.1.5 Test Result of AC Conducted Emission

Test Mode :	Mode 3	Temperature :	22~23°C
Test Engineer :	Jacky Jia	Relative Humidity :	44~46%
Test Voltage :	120Vac / 60Hz	Phase :	Line
Function Type :	GSM 1900 Idle + Bluetooth Idle + USB Cable (Data Link with Notebook)		
Remark :	All emissions not reported here are more than 10 dB below the prescribed limit.		

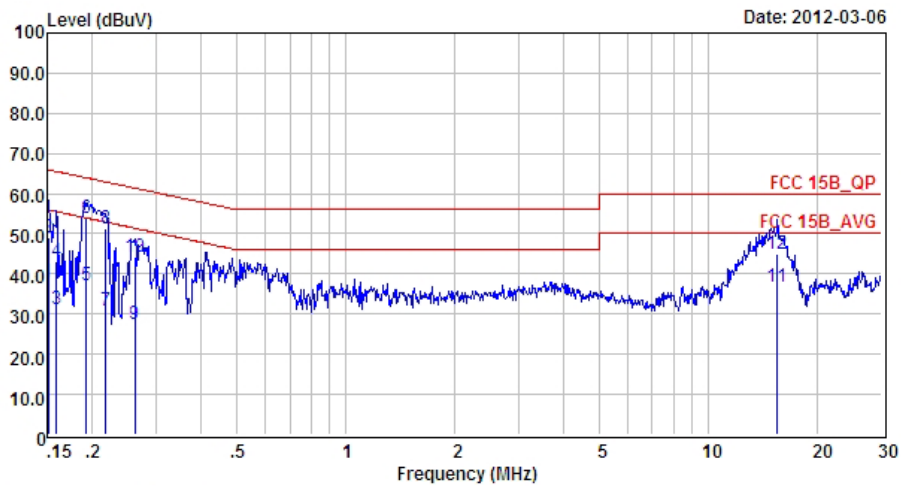

Site : CO01-SZ
 Condition: FCC 15B_QP LISN_L_2000601 LINE
 Project : (FD)221703
 Mode : Mode3

	Freq	Level	Over	Limit	Read	LISN	Cable	
	MHz	dBuV	Limit	Line	Level	Factor	Loss	Remark
			dB	dBuV	dBuV	dB	dB	
1	0.15	37.98	-17.98	55.96	27.90	0.03	10.05	Average
2	0.15	48.98	-16.98	65.96	38.90	0.03	10.05	QP
3	0.16	31.08	-24.44	55.52	21.00	0.03	10.05	Average
4	0.16	43.18	-22.34	65.52	33.10	0.03	10.05	QP
5	0.19	37.28	-16.65	53.93	27.20	0.03	10.05	Average
6	0.19	53.88	-10.05	63.93	43.80	0.03	10.05	QP
7	0.22	30.88	-22.04	52.92	20.80	0.02	10.06	Average
8	0.22	51.38	-11.54	62.92	41.30	0.02	10.06	QP
9	0.26	27.49	-23.89	51.38	17.41	0.02	10.06	Average
10	0.26	44.29	-17.09	61.38	34.21	0.02	10.06	QP
11	15.47	36.80	-13.20	50.00	26.10	0.25	10.45	Average
12	15.47	44.90	-15.10	60.00	34.20	0.25	10.45	QP



Test Mode :	Mode 3	Temperature :	22~23°C
Test Engineer :	Jacky Jia	Relative Humidity :	44~46%
Test Voltage :	120Vac / 60Hz	Phase :	Neutral
Function Type :	GSM 1900 Idle + Bluetooth Idle + USB Cable (Data Link with Notebook)		
Remark :	All emissions not reported here are more than 10 dB below the prescribed limit.		

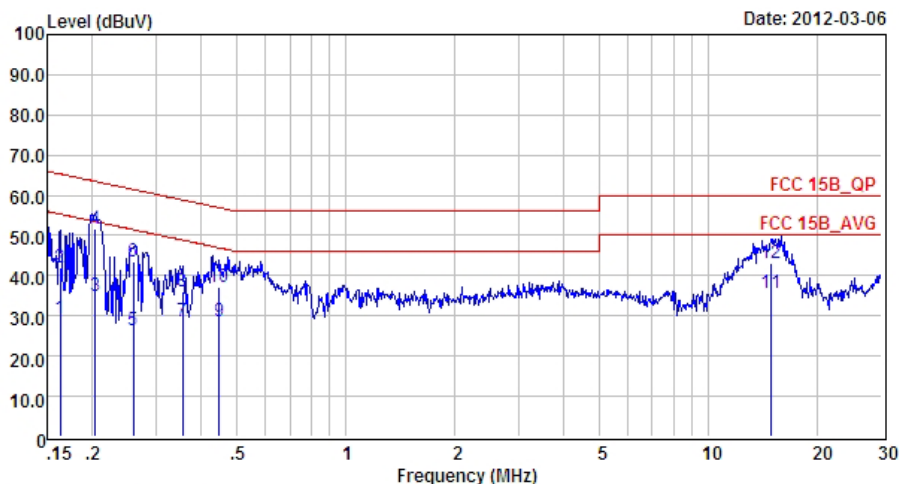

Site : CO01-SZ
 Condition: FCC 15B_QP LISN_N_2000601 NEUTRAL
 Project : (FD)221703
 Mode : Mode3

	Freq	Level	Over	Limit	Read	LISN	Cable	
	MHz	dBuV	Limit	Line	Level	Factor	Loss	Remark
			dB	dBuV	dBuV	dB	dB	
1	0.16	29.37	-25.93	55.30	19.30	0.02	10.05	Average
2	0.16	41.87	-23.43	65.30	31.80	0.02	10.05	QP
3	0.20	34.87	-18.58	53.45	24.79	0.02	10.06	Average
4	0.20	51.67	-11.78	63.45	41.59	0.02	10.06	QP
5	0.26	26.28	-25.19	51.47	16.20	0.02	10.06	Average
6	0.26	43.48	-17.99	61.47	33.40	0.02	10.06	QP
7	0.35	28.69	-20.18	48.87	18.60	0.02	10.07	Average
8	0.35	35.89	-22.98	58.87	25.80	0.02	10.07	QP
9	0.45	28.70	-18.23	46.93	18.60	0.02	10.08	Average
10	0.45	37.20	-19.73	56.93	27.10	0.02	10.08	QP
11	14.91	35.57	-14.43	50.00	24.80	0.34	10.43	Average
12	14.91	42.97	-17.03	60.00	32.20	0.34	10.43	QP

3.2. Test of Radiated Emission Measurement

3.2.1. Limit of Radiated Emission

The emissions from an intentional radiator shall not exceed the field strength levels specified in the following table:

Frequency (MHz)	Field Strength (microvolts/meter)	Measurement Distance (meters)
0.009 – 0.490	2400/F(KHz)	300
0.490 – 1.705	24000/F(KHz)	30
1.705 – 30.0	30	30
30 – 88	100	3
88 – 216	150	3
216 - 960	200	3
Above 960	500	3

3.2.2. Measuring Instruments

See list of measuring instruments of this test report.



3.2.3. Test Procedures

1. The EUT was placed on a turntable with 0.8 meter above ground.
2. The EUT was set 3 meters from the interference receiving antenna, which was mounted on the top of a variable height antenna tower.
3. The table was rotated 360 degrees to determine the position of the highest radiation.
4. The antenna is a Bi-Log antenna and its height is adjusted between one meter and four meters above ground to find the maximum value of the field strength for both horizontal polarization and vertical polarization of the antenna.
5. For each suspected emission, the EUT was arranged to its worst case and then tune the antenna tower (from 1 m to 4 m) and turntable (from 0 degree to 360 degrees) to find the maximum reading.
6. Set the test-receiver system to Peak Detect Function and specified bandwidth with Maximum Hold Mode.
7. If the emission level of the EUT in peak mode was 3 dB lower than the limit specified, then testing will be stopped and peak values of EUT will be reported, otherwise, the emissions will be repeated one by one using the quasi-peak method and reported
8. Emission level (dBuV/m) = 20 log Emission level (uV/m)
9. Corrected Reading: Antenna Factor + Cable Loss + Read Level - Preamp Factor = Level

3.2.4. Test Setup of Radiated Emission

For radiated emissions below 30MHz

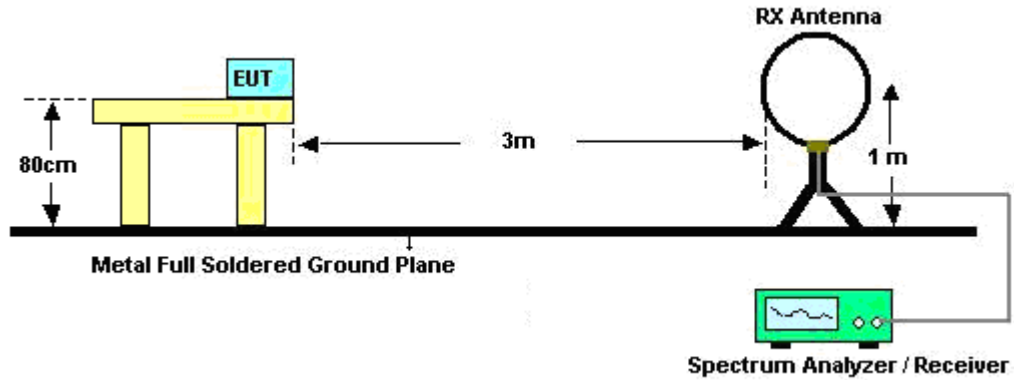

For radiated emissions above 30MHz

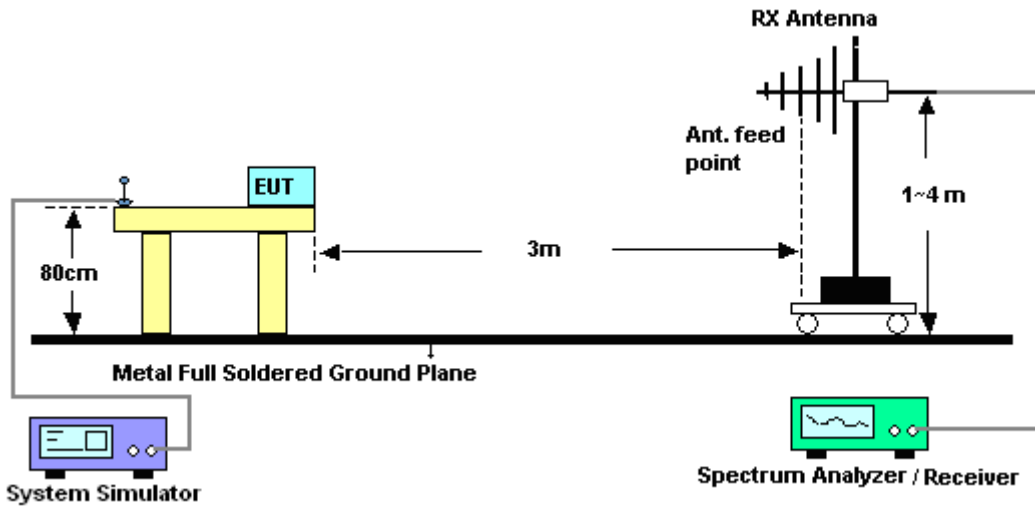

3.2.5. Test Results of Radiated Emissions (9 kHz ~ 30 MHz)

The low frequency, which started from 9 KHz to 30MHz, was pre-scanned and the result which was 20dB lower than the limit line per 15.31(o) was not reported.



3.2.6. Test Result of Radiated Emission

Test Mode :	Mode 4	Temperature :	21~22°C
Test Engineer :	Steven Hao	Relative Humidity :	41~42%
Test Distance :	3m	Polarization :	Horizontal
Function Type :	GSM 1900 Idle + Bluetooth Idle + USB Cable (Data Link with PC)		

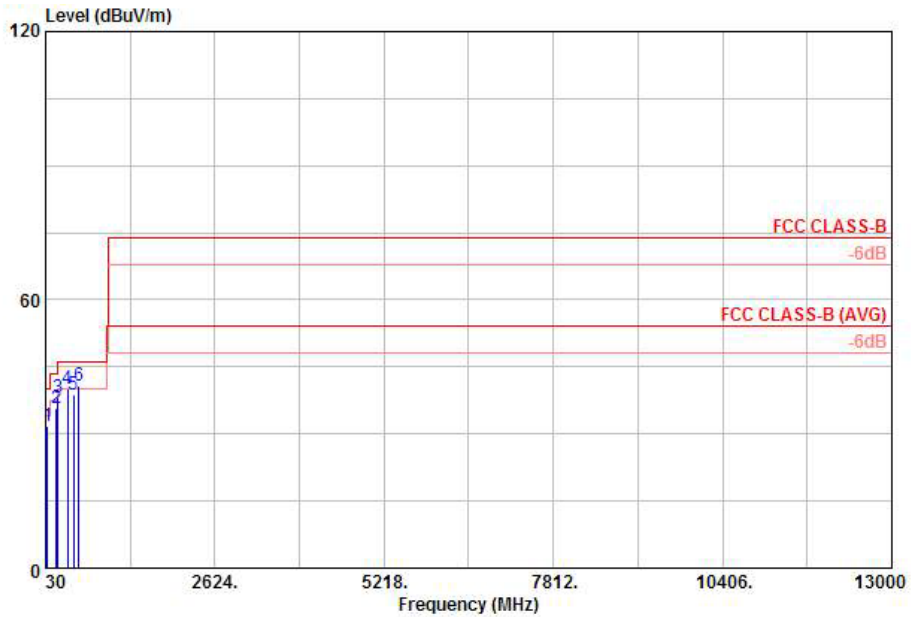

Site : 03CH01-KS
 Condition: FCC CLASS-B 3m LF_ANT_100803 HORIZONTAL
 Project : (FD) 221703
 Mode : mode 4

	Freq	Level	Over Limit	Limit Line	ReadAntenna Level	Antenna Factor	Cable Loss	Preamp Factor	Ant Pos	Table Pos	Remark
	MHz	dBuV/m	dB	dBuV/m	dBuV	dB/m	dB	dB	cm	deg	
1	57.81	31.76	-8.24	40.00	56.01	5.59	0.30	30.14	---	---	Peak
2	192.00	35.81	-7.69	43.50	56.60	8.59	0.58	29.96	---	---	Peak
3	216.03	38.11	-7.89	46.00	57.66	9.83	0.61	29.99	---	---	Peak
4 !	371.40	40.06	-5.94	46.00	54.04	15.09	0.83	29.90	---	---	Peak
5	456.10	38.86	-7.14	46.00	51.35	16.38	0.91	29.78	---	---	Peak
6 !	540.10	40.82	-5.18	46.00	51.21	18.31	0.99	29.69	100	119	Peak



Test Mode :	Mode 4	Temperature :	21~22°C
Test Engineer :	Steven Hao	Relative Humidity :	41~42%
Test Distance :	3m	Polarization :	Vertical
Function Type :	GSM 1900 Idle + Bluetooth Idle + USB Cable (Data Link with PC)		

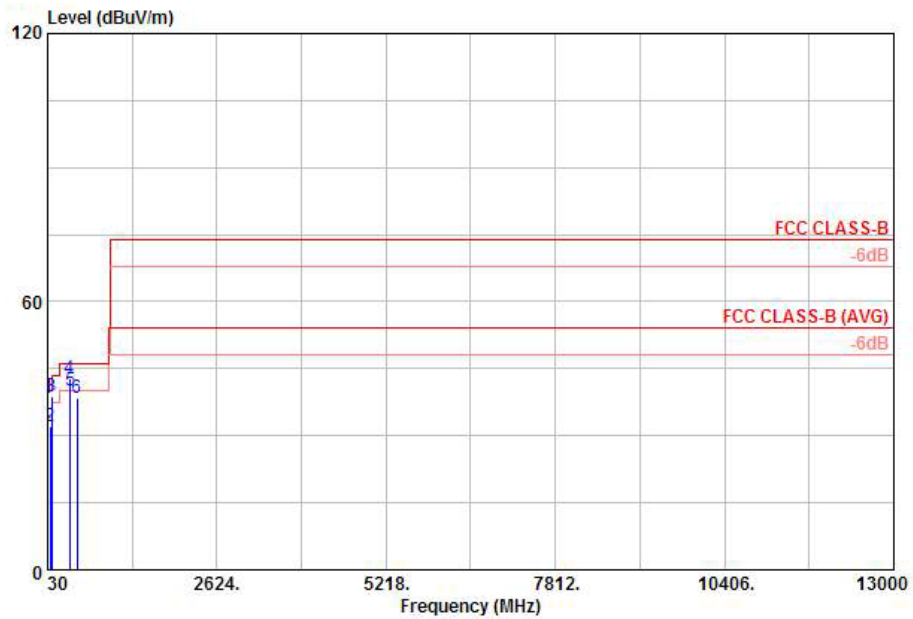

Site : 03CH01-KS
 Condition: FCC CLASS-B 3m LF_ANT_100803 VERTICAL
 Project : (FD) 221703
 Mode : mode 4

	Freq	Level	Over	Limit	ReadAntenna	Cable	Preamp	Ant	Table	Remark
	MHz	dBuV/m	dB	dBuV/m	dBuV	dB/m	dB	dB	cm	deg
1 !	30.00	38.48	-1.52	40.00	50.30	18.00	0.26	30.08	100	0 QP
2	66.72	32.16	-7.84	40.00	56.68	5.25	0.33	30.10	100	122 QP
3 !	89.94	38.94	-4.56	43.50	59.64	8.90	0.39	29.99	---	--- Peak
4 !	371.40	42.80	-3.20	46.00	56.78	15.09	0.83	29.90	---	--- Peak
5 !	384.00	40.12	-5.88	46.00	53.56	15.59	0.83	29.86	---	--- Peak
6	486.20	38.57	-7.43	46.00	50.37	16.99	0.95	29.74	---	--- Peak

4. List of Measuring Equipment

Instrument	Manufacturer	Model No.	Serial No.	Characteristics	Calibration Date	Test Date	Due Date	Remark
AC LISN	ETS-LINDGR EN	3816/2SH	00103912	0.1MHz~108M Hz	Feb. 27, 2012	Mar. 06, 2012	Feb. 26, 2013	Conduction (CO01-SZ)
AC LISN	ETS-LINDGR EN	3816/2SH	00103892	0.1MHz~108M Hz	Feb. 27, 2012	Mar. 06, 2012	Feb. 26, 2013	Conduction (CO01-SZ)
ESCIO TEST Receiver	R&S	1142.8007. 03	100724	9K-3GHz	Mar. 08, 2011	Mar. 06, 2012	Mar. 07, 2012	Conduction (CO01-SZ)
AVR	Throma	61602	616020000891	N/A	Oct. 12, 2011	Mar. 06, 2012	Oct. 11, 2012	Conduction (CO01-SZ)
AC LISN	SCHWARZBE CK	NNLK 8121	8121370	10KHz-30MHz	Jun. 13, 2011	Mar. 06, 2012	Jun. 12, 2012	Conduction (CO01-SZ)
System Simulator	Agilent	E5515C	MY50264168	GSM/WCDMA /CDMA2000	Mar. 14, 2011	Mar. 06, 2012	Mar. 13, 2012	Conduction (CO01-SZ)
EMI Test Receiver	R&S	ESCI	100534	9kHz~3GHz	Nov. 09, 2011	Mar. 14, 2012	Nov. 08, 2012	Radiation (03CH01-KS)
Spectrum Analyzer	R&S	FSP40	100319	9kHz~40GHz	Dec. 30, 2011	Mar. 14, 2012	Dec. 29, 2012	Radiation (03CH01-KS)
Bilog Antenna	SCHAFFNER	CBL6112D	23182	25MHz~2GHz	Dec. 08, 2011	Mar. 14, 2012	Dec. 07, 2012	Radiation (03CH01-KS)
Loop Antenna	R&S	HFH2-Z2	860004/00	9 kHz~30 MHz	Jul. 28, 2011	Mar. 14, 2012	Jul. 27, 2012	Radiation (03CH01-KS)
Double Ridge Horn Antenna	EMCO	3117	00075959	1GHz~18GHz	Jan. 06, 2012	Mar. 14, 2012	Jan. 05, 2013	Radiation (03CH01-KS)
Amplifier	Wireless	FPA-6592G	060007	30MHz~2GHz	Dec. 30, 2011	Mar. 14, 2012	Dec. 29, 2012	Radiation (03CH01-KS)
Amplifier	Agilent	8449B	3008A02370	1GHz~26.5GH z	Dec. 30, 2011	Mar. 14, 2012	Dec. 29, 2012	Radiation (03CH01-KS)
Active Horn Antenna	com-power	AHA-118	701023	1GHz~18GHz	Nov. 07, 2011	Mar. 14, 2012	Nov. 06, 2012	Radiation (03CH01-KS)
Signal Generator	R&S	SMR40	100455	10GHz~40GH z	Dec. 30, 2011	Mar. 14, 2012	Dec. 29, 2012	Radiation (03CH01-KS)
SHE-EHF Horn	Schwarzbeck	BBHA9170	BBHA170249	15GHz~40GH z	Oct. 11, 2011	Mar. 14, 2012	Oct. 10, 2012	Radiation (03CH01-KS)
System Simulator	R&S	CMU200	837587/066	2G Full-Band	Dec. 30, 2011	Mar. 14, 2012	Dec. 29, 2012	Radiation (03CH01-KS)

5. Uncertainty of Evaluation

Uncertainty of Conducted Emission Measurement (150 KHz ~ 30 MHz)

Contribution	Uncertainty of X_i		$u(X_i)$
	dB	Probability Distribution	
Receiver Reading	0.10	Normal (k=2)	0.05
Cable Loss	0.10	Normal (k=2)	0.05
AMN Insertion Loss	2.50	Rectangular	0.63
Receiver Specification	1.50	Rectangular	0.43
Site Imperfection	1.39	Rectangular	0.80
Mismatch	+0.34 / -0.35	U-Shape	0.24
Combined Standard Uncertainty $U_c(y)$	1.13		
Measuring Uncertainty for a Level of Confidence of 95% ($U = 2U_c(y)$)	2.26		

Uncertainty of Radiated Emission Measurement (30 MHz ~ 1000 MHz)

Contribution	Uncertainty of X_i		$u(X_i)$
	dB	Probability Distribution	
Receiver Reading	0.41	Normal (k=2)	0.21
Antenna Factor Calibration	0.83	Normal (k=2)	0.42
Cable Loss Calibration	0.25	Normal (k=2)	0.13
Pre-Amplifier Gain Calibration	0.27	Normal (k=2)	0.14
RCV/SPA Specification	2.50	Rectangular	0.72
Antenna Factor Interpolation for Frequency	1.00	Rectangular	0.29
Site Imperfection	1.43	Rectangular	0.83
Mismatch	+0.39 / -0.41	U-Shape	0.28
Combined Standard Uncertainty $U_c(y)$	1.27		
Measuring Uncertainty for a Level of Confidence of 95% ($U = 2U_c(y)$)	2.54		

Uncertainty of Radiated Emission Measurement (1 GHz ~ 40 GHz)

Contribution	Uncertainty of X_i		$u(X_i)$	C_i	$C_i * u(X_i)$
	dB	Probability Distribution			
Receiver Reading	± 0.10	Normal (k=2)	0.10	1	0.10
Antenna Factor Calibration	± 1.70	Normal (k=2)	0.85	1	0.85
Cable Loss Calibration	± 0.50	Normal (k=2)	0.25	1	0.25
Receiver Correction	± 2.00	Rectangular	1.15	1	1.15
Antenna Factor Directional	± 1.50	Rectangular	0.87	1	0.87
Site Imperfection	± 2.80	Triangular	1.14	1	1.14
Mismatch Receiver VSWR $\Gamma_1 = 0.197$ Antenna VSWR $\Gamma_2 = 0.194$ Uncertainty = $20\text{Log}(1-\Gamma_1*\Gamma_2)$	+0.34 / -0.35	U-Shape	0.244	1	0.244
Combined Standard Uncertainty $U_c(y)$	2.36				
Measuring Uncertainty for a Level of Confidence of 95% ($U = 2U_c(y)$)	4.72				



Appendix A. Photographs of EUT

Please refer to Sporton report number EP221703 as below.