



Test report No. : 31JE0290-SH-01-A
Page : 1 of 86
Issued date : July 26, 2011
FCC ID : WV2611849144431A
Revised date : September 5, 2011

RADIO TEST REPORT

Test Report No. : 31JE0290-SH-01-A

Applicant : **Panasonic Mobile Communications Co.,Ltd.**
Type of Equipment : **RRH4x40-PCS KS24829L11**
Model No. : **849144431**
Test regulation : **FCC Part 24: 2008**
FCC ID : **WV2611849144431A**
Test Result : **Complied**

1. This test report shall not be reproduced in full or partial, without the written approval of UL Japan, Inc.
2. The results in this report apply only to the sample tested.
3. This sample tested is in compliance with the limits of the above regulation.
4. The test results in this test report are traceable to the national or international standards.
5. This test report must not be used by the customer to claim product certification, approval, or endorsement by any agency of the Federal Government.
6. The opinions and the interpretations to the result of the description in this report are outside scopes where UL Japan has been accredited.

Date of test: June 17 to 27, 2011

Tested by: 
Kenichi Adachi
Engineer of WiSE Japan, UL
Verification Service

Approved by : 
Go Ishiwata
Manager of WiSE Japan, UL
Verification Service

UL Japan, Inc.

Shonan EMC Lab.

1-22-3 Megumigaoka, Hiratsuka-shi, Kanagawa-ken, 259-1220 JAPAN

Telephone : +81 463 50 6400

Facsimile : +81 463 50 6401

CONTENTS	PAGE
SECTION 1: Customer information	3
SECTION 2: Equipment under test (E.U.T.).....	3
SECTION 3: Test specification, procedures & results	4
SECTION 4: Operation of E.U.T. during testing	7
SECTION 5: Peak Output Power, Spurious emission and Band-Edge (Conducted/Radiated).....	9
SECTION 6: Bandwidth (Conducted)	10
SECTION 7: Frequency Stability (Conducted)	10
 Contents of APPENDIXES	 11

UL Japan, Inc.

Shonan EMC Lab.

1-22-3 Megumigaoka, Hiratsuka-shi, Kanagawa-ken, 259-1220 JAPAN

Telephone : +81 463 50 6400

Facsimile : +81 463 50 6401

SECTION 1: Customer information

Company Name : Panasonic Mobile Communications Co.,Ltd.
Brand Name : Panasonic
Address : 600 Saedo-cho, Tsuduki-ku, Yokohama-shi, Kanagawa-ken, 224-8539, Japan
Telephone Number : +81-50-3686-6079
Facsimile Number : +81-45-938-2456
Contact Person : Nakajo Tomohiko

SECTION 2: Equipment under test (E.U.T.)

2.1 Identification of E.U.T.

Type of Equipment : RRH4x40-PCS KS24829L11
Model Number : 849144431
Serial Number : LBALLU-M51121D159A, LBALLU-M51121D159B
Rating : DC -48V (typical), DC -37 V to -57V
Country of Mass-production : Japan
Condition of EUT : Production prototype
(Not for Sale: This sample is equivalent to mass-produced items.)
Receipt Date of Sample : June 15, 2011
Modification of EUT : The test lab did not make the modification to the EUT supplied from the customer to have it pass the tests.

2.2 Product Description

Model No.: 849144431 (referred to as the EUT in this report) is RRH4x40-PCS KS24829L11.
(PCS: Personal Communications Service, RRH: Remote Radio Head)

<Radio part>

Equipment type : Transceiver
Frequency of operation : Transmitting (Downlink): 1930.700MHz to 1994.300MHz
Receiving (Uplink): 1810.700MHz to 1914.300MHz
Radio part clock frequency : 61.44MHz
Bandwidth : CDMA: 1.25MHz
LTE: 1.4MHz, 3MHz, 5MHz, 10MHz, 15MHz, 20MHz
Type of modulation : LTE: 64QAM, 16QAM, QPSK
CDMA: QPSK, HPSK, BPSK,
RF Output Power : 40W (Average) at 1 port (at antenna terminal port)
RF Output Power Limit : (1640W/MHz (E.I.R.P., HAAT < 300m))
46.15dBm/MHz (= 41.19W/MHz) for antenna gain 16dBi
(= 62.15dBm/MHz (=1640W/MHz) – 16dBi)
Antenna type : N/A
Antenna connector type : N type
Antenna gain : (16dBi max)
ITU code : G1W / G7W / D1W / D7W
Operating Voltage (Radio part) : DC -48V
Operation temperature range : -40 deg.C. to +55 deg.C.

UL Japan, Inc. Shonan EMC Lab.

1-22-3 Megumigaoka, Hiratsuka-shi, Kanagawa-ken, 259-1220 JAPAN
Telephone : +81 463 50 6400
Facsimile : +81 463 50 6401

SECTION 3: Test specification, procedures & results

3.1 Test Specification

Test Specification : FCC Part 24 2008, final revised on May 2, 2008 with Amendment(s)
published in 73 FR 24183 on May 2, 2008 (Effective date: June 2, 2008)

Title : FCC 47CFR Part 24
Personal Communications Services

3.2 Procedures and results

Item	Test Method	FCC Regulations	Remarks	Deviation	Worst margin	Results
Peak Output Power	FCC Part2 Section 2.1046(a)	Section 24.232(a)(2)	Conducted	N/A	-	Complied
Emission Bandwidth, 99% Occupied Bandwidth	FCC Part2 Section 2.1049(h)	Section 24.238	Conducted	N/A	-	Complied
Band-Edge	FCC Part2 Section 2.1051 FCC Part24 Section 24.238(b)	Section 24.238(a),(b)	Conducted	N/A	-	Complied
Spurious Emission (Conducted)	FCC Part2 Section 2.1051	Section 24.238(a)	Conducted	N/A	-	Complied
Spurious Emission (Radiated)	FCC Part2 Section 2.1053	Section 24.238(a)	Radiated	N/A	[CDMA, (Mid ch)] 1.8dB, 15700.000MHz, Horizontal	Complied
Frequency Stability (Temperature Variation)	FCC Part2 Section 2.1055(a) (1) and (b)	Section 24.235	Conducted	N/A	-	Complied
Frequency Stability (Voltage Variation)	FCC Part2 Section 2.1055(d)(1) and (2)	Section 24.235	Conducted	N/A	-	Complied
Peak-to-Average Ratio	-	Section 24.232(d)	Conducted	N/A	-	Complied

Note: UL Japan, Inc.'s EMI Work Procedures No. 13-EM-W0420

*These tests were also referred to TIA-603-C "Land Mobile FM or PM Communications Equipment Measurement and Performance Standards."

UL Japan, Inc.

Shonan EMC Lab.

1-22-3 Megumigaoka, Hiratsuka-shi, Kanagawa-ken, 259-1220 JAPAN

Telephone : +81 463 50 6400

Facsimile : +81 463 50 6401

3.3 Addition to standard

	Item	Test Method	Regulations	Remarks	Deviation	Worst margin	Results
1	99% Occupied Band Width	RSS-Gen 4.6.1	RSS-Gen 4.6.1	Conducted	N/A	N/A	N/A

Other than above, no addition, exclusion nor deviation has been made from the standard.

3.4 Confirmation

UL Japan, Inc. hereby confirms that E.U.T., in the configuration tested, complies with the specifications FCC Part 24.

3.5 Uncertainty

The following uncertainties have been calculated to provide a confidence level of 95% using a coverage factor k=2.

Item	Frequency range	No.1 SAC ^{*1} (±)	No.2 SAC(±)	No.3 SAC (±)
Radiated emission (Substitution measurement;3m) (EUT height 0.8m)	30MHz-300MHz	4.8 dB	4.8 dB	4.8 dB
	300MHz-1GHz	3.8 dB	3.8 dB	3.8 dB
	1GHz-13GHz	5.8 dB	5.8 dB	5.8 dB
Radiated emission (Substitution measurement;1m) (EUT height 0.8m)	13GHz-18GHz	6.4 dB	6.4 dB	6.4 dB
	18GHz-26.5GHz	5.7 dB	5.7 dB	5.7 dB
	26.5GHz-40GHz	5.2 dB	5.2 dB	5.2 dB

*1: SAC=Semi-Anechoic Chamber

Radiated emission test(3m)

The data listed in this report meets the limits unless the uncertainty is taken into consideration.

Power Measurement uncertainty below 1GHz for this test was: (±) 0.8dB

Power Measurement uncertainty above 1GHz for this test was: (±) 0.8dB

Frequency (Normal condition) Measurement uncertainty for this test was: (±) 1.3 x 10⁻⁶.

Frequency (Extreme condition) Measurement uncertainty for this test was: (±) 1.3 x 10⁻⁶.

Conducted emissions, Power Density Measurement (below 1GHz) uncertainty for this test was: (±) 1.1dB

Conducted emissions, Power Density Measurement (1G-3GHz) uncertainty for this test was: (±) 1.2dB

Conducted emissions, Power Density Measurement (3G-18GHz) uncertainty for this test was: (±) 2.9dB

Conducted emissions Measurement (18G-26.5GHz) uncertainty for this test was: (±) 4.1dB

Frequency Measurement uncertainty for this test was: (±) 2.1%

Bandwidth Measurement uncertainty for this test was: (±) 5.4%

UL Japan, Inc. Shonan EMC Lab.

1-22-3 Megumigaoka, Hiratsuka-shi, Kanagawa-ken, 259-1220 JAPAN

Telephone : +81 463 50 6400

Facsimile : +81 463 50 6401

3.6 Test Location

UL Japan, Inc. Shonan EMC Lab.
1-22-3, Megumigaoka, Hiratsuka-shi, Kanagawa-ken 259-1220 JAPAN
Telephone number : +81 463 50 6400
Facsimile number : +81 463 50 6401
JAB Accreditation No. : RTL02610

No.1/ No.2/ No.3 anechoic chamber has been fully described in a report submitted to FCC office, and accepted on April 17, 2009 (Registration No.: 697847).

IC Registration No. : 2973D-1 (No1 Semi-Anechoic Chamber)
2973D-2 (No2 Semi-Anechoic Chamber)
2973D-3 (No3 Semi-Anechoic Chamber)

Test room	Width x Depth x Height (m)	Test room	Width x Depth x Height (m)
No.1 Semi-Anechoic Chamber	20.6 x 11.3 x 7.65 Maximum measurement distance: 10m	No.1 Shielded room	6.8 x 4.1 x 2.7
No.2 Semi-Anechoic Chamber	20.6 x 11.3 x 7.65 Maximum measurement distance: 10m	No.2 Shielded room	6.8 x 4.1 x 2.7
No.3 Semi-Anechoic Chamber	12.7 x 7.7 x 5.35 Maximum measurement distance: 5m	No.3 Shielded room	6.3 x 4.7 x 2.7
No.4 Semi-Anechoic Chamber	8.1 x 5.1 x 3.55	No.4 Shielded room	4.4 x 4.7 x 2.7
		No.5 Shielded room	7.8 x 6.4 x 2.7
		No.6 Shielded room	7.8 x 6.4 x 2.7

3.7 Test set up, Data of EMI, and Test instruments

Refer to APPENDIX.

UL Japan, Inc. Shonan EMC Lab.

1-22-3 Megumigaoka, Hiratsuka-shi, Kanagawa-ken, 259-1220 JAPAN
Telephone : +81 463 50 6400
Facsimile : +81 463 50 6401

SECTION 4: Operation of E.U.T. during testing

4.1 Operating Modes

The mode is used :

for Radiated emission tests:

- (1) CDMA (Low ch):
CDMA mode, worst mode: 1 carrier, worst antenna port: TX1, transmitting 1930.70MHz,
- (2) CDMA (Mid ch):
CDMA mode, worst mode: 1 carrier, worst antenna port: TX1, transmitting 1962.50MHz,
- (3) CDMA (High ch):
CDMA mode, worst mode: 1 carrier, worst antenna port: TX1, transmitting 1994.30MHz,
- (4) LTE (Low ch):
LTE mode, worst mode: 1 carrier, 1.4MHz band, antenna port: ALL, transmitting 1930.70MHz,
- (5) LTE (Mid ch):
LTE mode, worst mode: 1 carrier, 1.4MHz band, antenna port: ALL, transmitting 1962.50MHz,
- (6) LTE (High ch):
LTE mode, worst mode: 1 carrier, 1.4MHz band, antenna port: ALL, transmitting 1994.30MHz,

for bandedge and spurious emission (conducted) tests:

- (1) CDMA, worst mode: 1 carrier, worst antenna port: TX1, transmitting 1930.70MHz,
- (2) CDMA, worst mode: 1 carrier, worst antenna port: TX1, transmitting 1962.50MHz,
- (3) CDMA, worst mode: 1 carrier, worst antenna port: TX1, transmitting 1994.30MHz,
- (4) LTE, worst mode: 1 carrier, 1.4MHz band, worst antenna port: TX2, transmitting 1930.70MHz,
- (5) LTE, worst mode: 1 carrier, 1.4MHz band, worst antenna port: TX2, transmitting 1962.50MHz,
- (6) LTE, worst mode: 1 carrier, 1.4MHz band, worst antenna port: TX2, transmitting 1994.30MHz,

* These mode were worst mode and had decided by pre-check tests (Peak Output Power and Bandwidth tests).
The bandedge measurement of LTE mode were done only with 1 carrier, because 1 carrier and 2 carrier were compared and 1 carrier of both output power and bandwidth were worse,

for frequency stability tests:

- (1) Tx CW: None modulation, transmitting 1930.70MHz,
- (2) Tx CW: None modulation, transmitting 1962.50MHz,
- (3) Tx CW: None modulation, transmitting 1994.30MHz,

* Justification: The system was configured in typical fashion (as a customer would normally use it) for testing.

Used test programs:

BBU-sim Contriller Version 5.1 (Rev.1266) (exluse/comisis Inc.),
Message definition Version ISSUE 3.11 (exluse/comisis Inc.),
EUT's firmware V02.00.01 (used only when change of frequency range)

(Reference: EUT's mode)

EUT's antenna port: TX1, TX2, TX3, TX4

CDMA transmitting mode							
1 carrier out	2 carrier out	3 carrier out	4 carrier out	5 carrier out	6 carrier out	7 carrier out	8 carrier out

LTE transmitting mode						
1 carrier out	1.4MHz band	3MHz band	5MHz band	10MHz band	15MHz band	20MHz band
2 carrier out	1.4MHz band	3MHz band	5MHz band	10MHz band	-	-

UL Japan, Inc. Shonan EMC Lab.

1-22-3 Megumigaoka, Hiratsuka-shi, Kanagawa-ken, 259-1220 JAPAN
Telephone : +81 463 50 6400
Facsimile : +81 463 50 6401

4.2 Configuration and peripherals

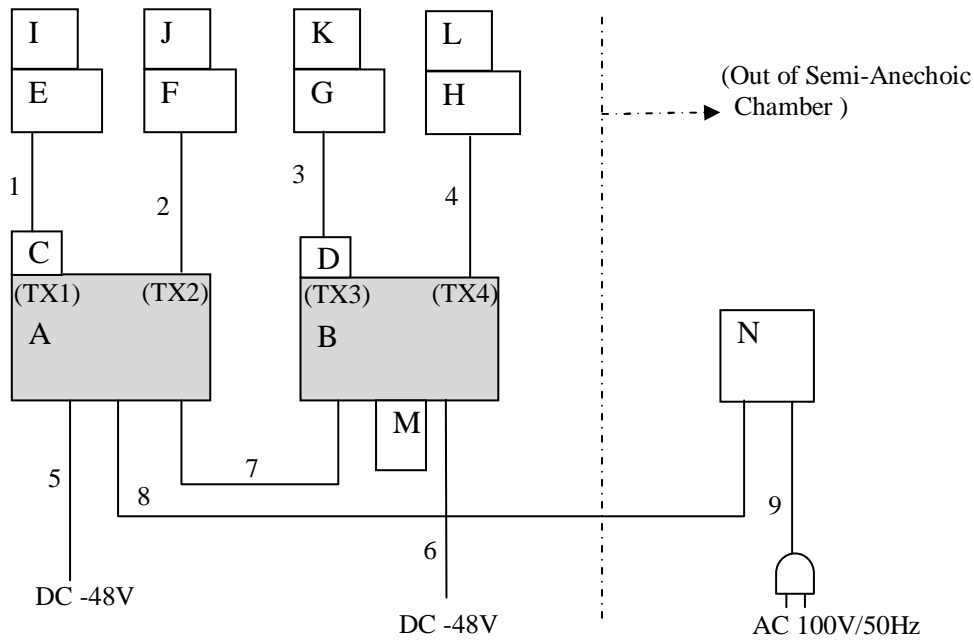

* Cabling and setup were taken into consideration and test data was taken under worst case conditions.

Description of EUT and Support equipment

No.	Item	Model number	Serial number	Manufacturer	Remarks	FCC ID
A	RRH4x40-PCS KS24829L11	849144431	LBALLU- M51121D159A	Panasonic Mobile Communications	EUT (1st)	WV26118491 44431A
B	RRH4x40-PCS KS24829L11	849144431	LBALLU- M51121D159B	Panasonic Mobile Communications	EUT (2nd)	WV26118491 44431A
C	DC cutter	8532-NI-HV	-	INMET	-	-
D	DC cutter	8532-NI-HV	-	INMET	-	-
E	Attenuator	16-0636 N	101235-001	Diconex	(40dB, 250W)	-
F	Attenuator	16-0636 N	101235-006	Diconex	(40dB, 250W)	-
G	Attenuator	16-0636 N	101235-007	Diconex	(40dB, 250W)	-
H	Attenuator	16-0636 N	101235-008	Diconex	(40dB, 250W)	-
I	Terminator	7G07	-	Mpd	(50ohm)	-
J	Terminator	7G07	-	Mpd	(50ohm)	-
K	Terminator	7G07	-	Mpd	(50ohm)	-
L	Terminator	7G07	-	Mpd	(50ohm)	-
M	ALM cap	-	-	-	for 2nd EUT	-
N	BBU-simulator	BBU-SIM2	888009	-	-	-

List of cables used

No.	Cable name	Length (m)	Shield		Remark
			Cable	Connector	
1	Antenna	2.0	Shielded	Shielded	-
2	Antenna	2.0	Shielded	Shielded	-
3	Antenna	2.0	Shielded	Shielded	-
4	Antenna	2.0	Shielded	Shielded	-
5	DC	3.6	Unshielded	Unshielded	-
6	DC	3.6	Unshielded	Unshielded	-
7	Optical cable	5.0	-	-	Optical cable
8	Optical cable	10.0	-	-	Optical cable
9	AC	2.0	Unshielded	Unshielded	-

UL Japan, Inc. Shonan EMC Lab.

1-22-3 Megumigaoka, Hiratsuka-shi, Kanagawa-ken, 259-1220 JAPAN
Telephone : +81 463 50 6400
Facsimile : +81 463 50 6401

SECTION 5: Peak Output Power, Spurious emission and Band-Edge

(Conducted/Radiated)

[Conducted]

Test Procedure

The peak output power (conducted) was measured with a spectrum analyzer or a power meter, and an attenuator was connected with the antenna port.

The Spurious emission and Band-Edge (conducted) was measured with a spectrum analyzer, and an attenuator was connected with the antenna port.

* In the frequency range below 30MHz, RBW was narrowed to separate the noise contents.

Then, wide-band noise near the limit was checked separately, however the noise was not detected as shown in the chart. (9kHz-150kHz:RBW=200Hz, 150kHz-30MHz:RBW=10kHz)

Test data : **APPENDIX 2**
Test result : **Pass**

[Radiated]

Test Procedure

- 1) EUT was placed on a urethane platform of nominal size, 0.5m by 1.0m, raised 80cm above the conducting ground plane. Test was made with the antenna positioned in both the horizontal and vertical planes of polarization.
The Radiated Electric Field Strength intensity has been measured in a semi anechoic chamber with a ground plane and at a distance of 3m.
The measuring antenna height was varied between 1 to 4m and EUT was rotated a full revolution in order to obtain the maximum value of the electric field intensity.

- 2) Exchanged the EUT to the Substitution Antenna, the measurement was set for the same height as the EUT. The frequency below 1GHz of the Substitution Antenna was used as the Half wave dipole Antenna, which is harmonized with the measured frequency in 1).
The frequency above 1GHz of the Substitution Antenna was used with Horn Antenna.
The Substitution Antenna was connected with the Signal Generator, and the polarized electromagnetic radiation of the Substitution Antenna was matched with the one of the measuring Antenna, which was set with the Signal Generator to the measured frequency in 1). Then, we set with the Output power (CW) of the Signal Generator where the measuring electromagnetic field is equal to the measured value in 1).
The measuring antenna height varied between 1 and 4m to obtain the maximum receiving level.
Its Output power of Signal Generator was recorded.

- 3) Effective radiated power was calculated by subtracting the cable loss and the attenuator loss connected between the Signal Generator and the Substitution Antenna from the Output power of the Signal Generator recorded in 2).
For the usage of the Antenna (Horn Antenna) except for the Half wave dipole Antenna (2.15dBi) for the Substitution Antenna, the Equivalent isotropic radiated power was calculated by compensating the finite difference in the Antenna gain of the isotropic Antenna (Antenna gain: 0dBi), and Substitution Antenna.

- The EUT was tested in the direction normally used.

Test data : **APPENDIX 2**
Test result : **Pass**

UL Japan, Inc. **Shonan EMC Lab.**

1-22-3 Megumigaoka, Hiratsuka-shi, Kanagawa-ken, 259-1220 JAPAN
Telephone : +81 463 50 6400
Facsimile : +81 463 50 6401

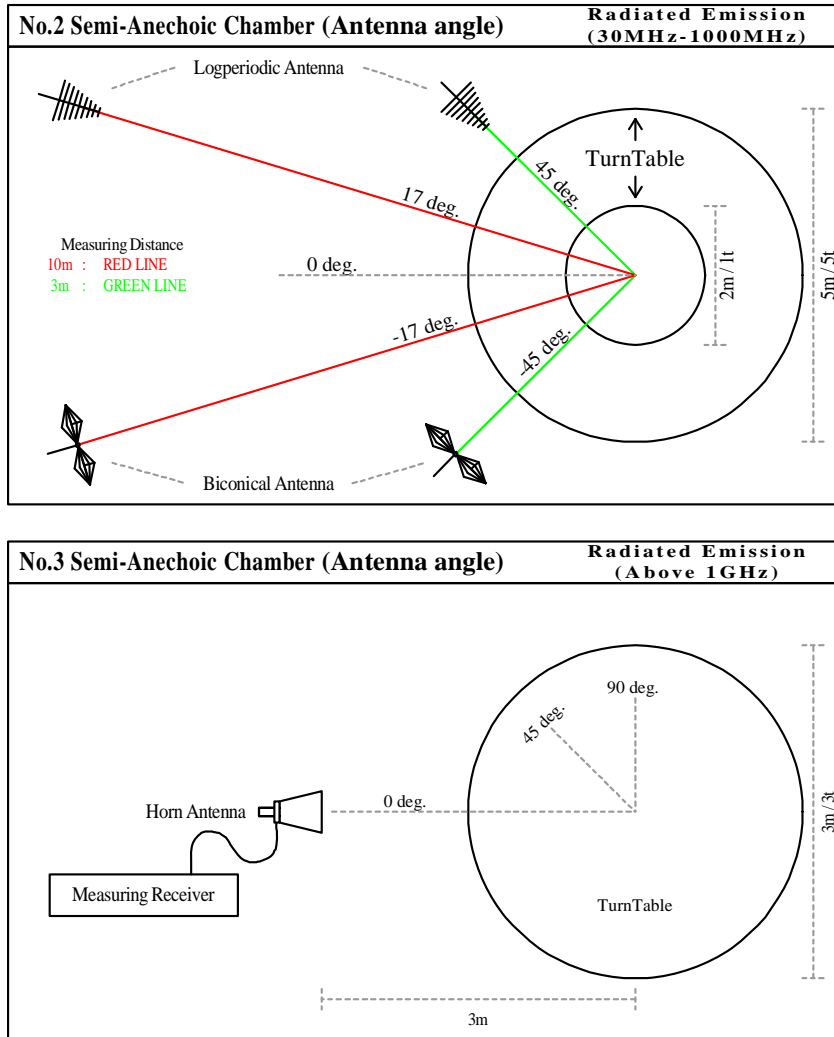

Figure 1

SECTION 6: Bandwidth (Conducted)

Test Procedure

The Emission Bandwidth, 99% Occupied Bandwidth was measured with a spectrum analyzer, and an attenuator was connected with the antenna port.

Test data : APPENDIX 2
Test result : Pass

SECTION 7: Frequency Stability (Conducted)

Test Procedure

The Frequency Stability was measured with a frequency counter.

Test data : APPENDIX 2
Test result : Pass

UL Japan, Inc.
Shonan EMC Lab.

1-22-3 Megumigaoka, Hiratsuka-shi, Kanagawa-ken, 259-1220 JAPAN
Telephone : +81 463 50 6400
Facsimile : +81 463 50 6401

Contents of APPENDIXES

APPENDIX 1: Photographs of test setup

Radiated emission	Page 12
Antenna terminal tests	Page 13

APPENDIX 2: Data of EMI test

Peak output power (include PAR).....	Page 14 - 20
Bandwidth	Page 21 - 44
Spurious emission (Antenna port conducted, include bandedge).....	Page 45 - 61
Radiated emission	Page 62 - 83
Frequency stability.....	Page 84

APPENDIX 3: Test instruments

Test instruments.....	Page 85 - 86
-----------------------	--------------

UL Japan, Inc.

Shonan EMC Lab.

1-22-3 Megumigaoka, Hiratsuka-shi, Kanagawa-ken, 259-1220 JAPAN

Telephone : +81 463 50 6400

Facsimile : +81 463 50 6401