



MET Laboratories, Inc. *Safety Certification - EMI - Telecom Environmental Simulation*

914 WEST PATAPSCO AVENUE • BALTIMORE, MARYLAND 21230-3432 • PHONE (410) 354-3300 • FAX (410) 354-3313

33439 WESTERN AVENUE • UNION CITY, CALIFORNIA 94587 • PHONE (510) 489-6300 • FAX (510) 489-6372

3162 BELICK STREET • SANTA CLARA, CA 95054 • PHONE (408) 748-3585 • FAX (510) 489-6372

13301 MCCALLEN PASS • AUSTIN, TEXAS 78753 • PHONE (512) 287-2500 • FAX (512) 287-2513

December 29, 2016

Viavi Solutions
20250 Century Blvd.
Germantown, MD 20874

Dear Jaryk Kuzel,

Enclosed is the EMC Wireless test report for compliance testing of the Viavi Solutions, TB/MTS-5800-100G, with Expansion Module as tested to the requirements of Title 47 of the CFR, Ch. 1 (10-1-06 ed.), FCC Part 15 Subpart C and RSS-247, Issue 1, May 2015 for Intentional Radiators.

Thank you for using the services of MET Laboratories, Inc. If you have any questions regarding these results or if MET can be of further service to you, please feel free to contact me.

Sincerely yours,
MET LABORATORIES, INC.

Amy Graziano
Documentation Department

Reference: (\\Viavi Solutions\EMC92235-FCC247)

Certificates and reports shall not be reproduced except in full, without the written permission of MET Laboratories, Inc.

Electromagnetic Compatibility Criteria Test Report

for the

**Viavi Solutions
TB/MTS-5800-100G, with Expansion Module**

Tested under
the FCC Certification Rules
contained in
15.247 Subpart C & RSS-247, Issue 1, May 2015
for Intentional Radiators

MET Report: EMC92235-FCC247

December 29, 2016

Prepared For:

**Viavi Solutions
20250 Century Blvd.
Germantown, MD 20874**

Prepared By:
MET Laboratories, Inc.
914 West Patapsco Avenue
Baltimore, MD 21230

**Electromagnetic Compatibility Criteria
Test Report**

for the

**Viavi Solutions
TB/MTS-5800-100G, with Expansion Module**

Tested under
the FCC Certification Rules
contained in
15.247 Subpart C & RSS-247, Issue 1, May 2015
for Intentional Radiators



Jun Qi, Project Engineer
Electromagnetic Compatibility Lab



Amy Graziano
Documentation Department

Engineering Statement: The measurements shown in this report were made in accordance with the procedures indicated, and the emissions from this equipment were found to be within the limits applicable. I assume full responsibility for the accuracy and completeness of these measurements, and for the qualifications of all persons taking them. It is further stated that upon the basis of the measurements made, the equipment tested is capable of operation in accordance with the requirements of the FCC Rules Parts 15B, 15.247 and Industry Canada RSS-247, Issue 1, May 2015 under normal use and maintenance.



Asad Bajwa,
Director, Electromagnetic Compatibility Lab

Report Status Sheet

Revision	Report Date	Reason for Revision
∅	December 29, 2016	Initial Issue.

Table of Contents

I.	Executive Summary	1
	A. Purpose of Test	2
	B. Executive Summary	2
II.	Equipment Configuration	3
	A. Overview.....	4
	B. References.....	5
	C. Test Site	5
	D. Description of Test Sample.....	6
	E. Equipment Configuration.....	8
	F. Support Equipment	8
	G. Ports and Cabling Information.....	9
	H. Mode of Operation.....	10
	I. Method of Monitoring EUT Operation	12
	J. Modifications	13
	a) Modifications to EUT.....	13
	b) Modifications to Test Standard.....	13
	K. Disposition of EUT	13
III.	Electromagnetic Compatibility Criteria for Intentional Radiators.....	14
	§ 15.207(a) Conducted Emissions Limits.....	15
IV.	Test Equipment	19
V.	Certification & User’s Manual Information	21
	A. Certification Information	22
	B. Label and User’s Manual Information	26
VI.	ICES-003 Procedural & Labeling Requirements.....	28

List of Tables

Table 1. Executive Summary of EMC Part 15.247 Compliance Testing	2
Table 2. EUT Summary Table.....	4
Table 3. References	5
Table 4. Equipment Configuration	8
Table 5. Support Equipment.....	8
Table 6. Ports and Cabling Information	9
Table 7. Conducted Limits for Intentional Radiators from FCC Part 15 § 15.207(a)	15
Table 8. Conducted Emissions, 15.207(a), Phase Line, Test Results	16
Table 9. Conducted Emissions, 15.207(a), Neutral Line, Test Results	17
Table 10. Test Equipment List	20

List of Plots

Plot 1. Conducted Emissions, 15.207(a), Phase Line	16
Plot 2. Conducted Emissions, 15.207(a), Neutral Line	17

List of Figures

Figure 1. Block Diagram of Test Configuration.....	7
--	---

List of Photographs

Photograph 1. Viavi Solutions TB/MTS-5800-100G, with Expansion Module.....	6
Photograph 2. Conducted Emissions, 15.207(a), Test Setup.....	18

List of Terms and Abbreviations

AC	Alternating Current
ACF	Antenna Correction Factor
Cal	Calibration
<i>d</i>	Measurement Distance
dB	Decibels
dB μ A	Decibels above one microamp
dB μ V	Decibels above one microvolt
dB μ A/m	Decibels above one microamp per meter
dB μ V/m	Decibels above one microvolt per meter
DC	Direct Current
E	Electric Field
DSL	Digital Subscriber Line
ESD	Electrostatic Discharge
EUT	Equipment Under Test
<i>f</i>	Frequency
FCC	Federal Communications Commission
GRP	Ground Reference Plane
H	Magnetic Field
HCP	Horizontal Coupling Plane
Hz	Hertz
IEC	International Electrotechnical Commission
kHz	kilohertz
kPa	kilopascal
kV	kilovolt
LISN	Line Impedance Stabilization Network
MHz	Megahertz
μ H	microhenry
μ	microfarad
μ s	microseconds
NEBS	Network Equipment-Building System
PRF	Pulse Repetition Frequency
RF	Radio Frequency
RMS	Root-Mean-Square
TWT	Traveling Wave Tube
V/m	Volts per meter
VCP	Vertical Coupling Plane

I. Executive Summary

A. Purpose of Test

An EMC evaluation was performed to determine compliance of the Viavi Solutions TB/MTS-5800-100G, with Expansion Module, with the requirements of Part 15, §15.247. All references are to the most current version of Title 47 of the Code of Federal Regulations in effect. In accordance with §2.1033, the following data is presented in support of the Certification of the TB/MTS-5800-100G, with Expansion Module. Viavi Solutions should retain a copy of this document which should be kept on file for at least two years after the manufacturing of the TB/MTS-5800-100G, with Expansion Module, has been **permanently** discontinued.

B. Executive Summary

The following tests were conducted on a sample of the equipment for the purpose of demonstrating compliance with Part 15, §15.247, in accordance with Viavi Solutions, purchase order number 294119230. All tests were conducted using measurement procedure ANSI C63.4-2003.

FCC Reference 47 CFR Part 15.247:2005	IC Reference RSS-247 Issue 1: 2015; RSS-GEN Issue 3: 2010	Description	Compliance
Title 47 of the CFR, Part 15 §15.207(a)	RSS-GEN (7.2.4)	Conducted Emission Limits	Compliant

Table 1. Executive Summary of EMC Part 15.247 Compliance Testing

II. Equipment Configuration

A. Overview

MET Laboratories, Inc. was contracted by Viavi Solutions to perform testing on the TB/MTS-5800-100G, with Expansion Module, under Viavi Solutions' purchase order number 294119230.

This document describes the test setups, test methods, required test equipment, and the test limit criteria used to perform compliance testing of the Viavi Solutions, TB/MTS-5800-100G, with Expansion Module.

The results obtained relate only to the item(s) tested.

Model(s) Tested:	TB/MTS-5800-100G, with Expansion Module	
Model(s) Covered:	TB/MTS-5800-100G, with Expansion Module	
EUT Specifications:	Primary Power: 100-240VAC	
	FCC ID: WUW-5800CTWB IC: 9613A-5800CTWB	
	Type of Modulations:	GFSK, $\pi/4$ -DQPSK, 8DPSK (Bluetooth 2.1+EDR) CCK, OFDM (WiFi 802.11 b/g/n)
	Equipment Code:	DSS and DTS
	Peak RF Output Power:	2.4GHz WIFI: 12.3 dBm @ 2412MHz
	EUT Frequency Ranges:	2402 – 2480 MHz and 2412 – 2462 MHz
Analysis:	The results obtained relate only to the item(s) tested.	
Environmental Test Conditions:	Temperature: 15-35° C	
	Relative Humidity: 30-60%	
	Barometric Pressure: 860-1060 mbar	
Evaluated by:	Jun Qi	
Report Date(s):	December 29, 2016	

Table 2. EUT Summary Table

B. References

CFR 47, Part 15, Subpart C	Federal Communication Commission, Code of Federal Regulations, Title 47, Part 15: General Rules and Regulations, Allocation, Assignment, and Use of Radio Frequencies
CFR 47, Part 15, Subpart B	Electromagnetic Compatibility: Criteria for Radio Frequency Devices
RSS-247, Issue 1, May 2015	Digital Transmission Systems (DTSS), Frequency Hopping Systems (FHSs) and Licence-Exempt Local Area Network (LE-LAN) Devices
RSS-GEN, Issue 3, Dec. 2010	General Requirements and Information for the Certification of Radio Apparatus
ANSI C63.4:2003	Methods and Measurements of Radio-Noise Emissions from Low-Voltage Electrical And Electronic Equipment in the Range of 9 kHz to 40 GHz
ISO/IEC 17025:2005	General Requirements for the Competence of Testing and Calibration Laboratories
ANSI C63.10-2009	American National Standard for Testing Unlicensed Wireless Devices

Table 3. References

C. Test Site

All testing was performed at MET Laboratories, Inc., 3162 Belick St., Santa Clara, CA. All equipment used in making physical determinations is accurate and bears recent traceability to the National Institute of Standards and Technology.

Radiated Emissions measurements were performed in a 10 meter semi-anechoic chamber (equivalent to an Open Area Test Site). In accordance with §2.948(a)(3), a complete site description is contained at MET Laboratories.

D. Description of Test Sample

The Viavi Solutions TB/MTS-5800-100G, with Expansion Module, Equipment Under Test (EUT), is a multi-rate handheld network tester used to evaluate telecommunications circuits. These circuits include but are not limited to Ethernet (10Mbps – 100Gbps), SONET/SDH (STS1, OC3 - OC192), OTN (up to 111.8Gbps), Fibre Channel (1Gig – 16Gig), and PDH (DS1, DS3, STM1, E1, E3, E4).

All interfaces are isolated from the outside plant. Power is supplied by an external AC/DC converter or by the internal battery. GPS synchronized timing is provided by an optionally-attached C5TEM-R module.

The unit is intended to be used by telecommunications network provisioning and maintenance technicians located in network operations centers, central offices, and customer premises (not residential).



Photograph 1. Viavi Solutions TB/MTS-5800-100G, with Expansion Module

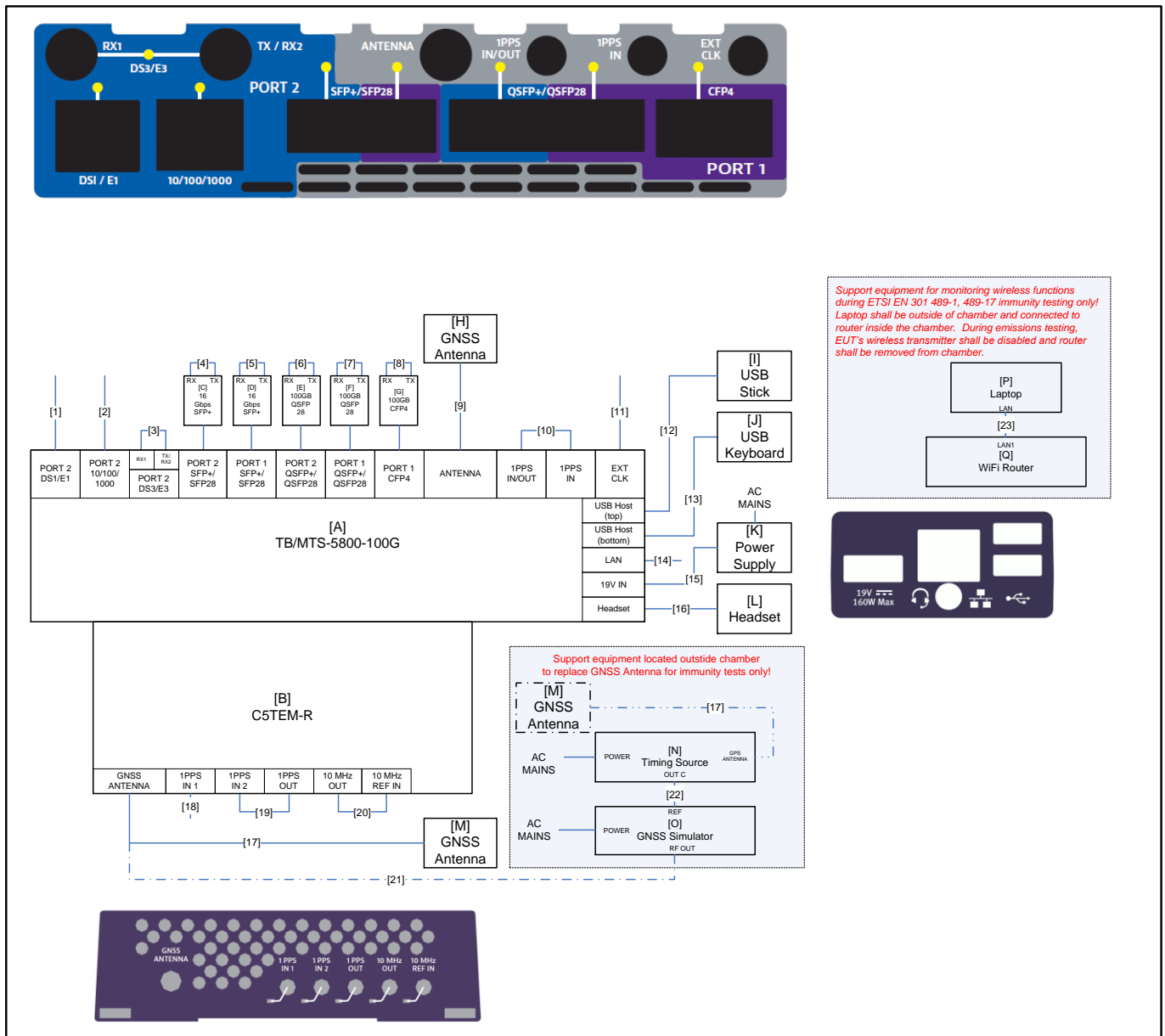

Figure 1. Block Diagram of Test Configuration

E. Equipment Configuration

The EUT was set up as outlined in Figure 1, Block Diagram of Test Setup. All cards, racks, etc., incorporated as part of the EUT is included in the following list.

Ref. ID	Slot #	Name / Description	Model Number	Part Number	Serial Number	Rev. #
A	NA	TB/MTS-5800-100G	TB/MTS-5800-100G	22114160	--	--
B	Expansion	C5TEM-R	C5TEM-R	22108483	--	--
C	Port2 SFP+/ SFP28	16Gbps SFP+	--	--	--	--
D	Port1 SFP+/ SFP28	16Gbps SFP+	--	--	--	--
E	Port2 QSFP+/ QSFP28	100Gbps QSFP28	--	--	--	--
F	Port1 QSFP+/ QSFP28	100Gbps QSFP28	--	--	--	--
G	Port1 CFP4	100Gbps CFP4	--	--	--	--
H	NA	USB Stick (4GB)	--	--	--	--
I	NA	GNSS Antenna	--	--	--	--
J	NA	USB Keyboard	Grandtec FLX-500U	82-018172	NA	NA
K	NA	Power Supply	--	--	--	--
L	NA	Headset	Plantronics M110	10-017673	NA	001
M	NA	GNSS Antenna	--	--	--	--

Table 4. Equipment Configuration

F. Support Equipment

Support equipment necessary for the operation and testing of the EUT is included in the following list.

Ref. ID	Name / Description	Manufacturer	Model Number
N	Timing Source	--	--
O	GNSS Simulator	--	--
P	Laptop	--	--
Q	WiFi Router	--	--

Table 5. Support Equipment

G. Ports and Cabling Information

Ref. ID	Port name on EUT	Cable Description or reason for no cable	Qty	Length as tested (m)	Max Length (m)	Shielded? (Y/N)	Termination Box ID & Port Name
Base Unit							
1	[A] PORT 2 DS1/E1	--	--	--	--	--	--
2	[A] PORT 2 10/100/1000	CAT5/5e/6,UTP	1	7.6	100m	N	[A] PORT 2 10/100/1000 loopback
3	[A] PORT 2 DS3/E3 TX/RX2	--	--	--	--	Y	[A] PORT 2 DS3/E3 RX1
4	[C] TX	optical	1	N/A	N/A	N	[C] RX
5	[D] TX	optical	1	N/A	N/A	N	[D] RX
6	[E] TX	optical	1	N/A	N/A	N	[E] RX
7	[F] TX	optical	1	N/A	N/A	N	[F] RX
8	[G] TX	optical	1	N/A	N/A	N	[G] RX
9	[A] Antenna	Antenna integrated cable: 50Ω coaxial, RG-174/U,SMA	2	3m	3m	Y	[H] GNSS Antenna
10	[A] 1PPS IN/OUT	50Ω coaxial, RG-174/U,SMB	1	3m	7.5m	Y	[A] 1PPS IN
11	[A] EXT CLK	50Ω coaxial, RG-174/U,SMB	1	3m	7.5m	Y	unterminated
12	[A] USB Host (top)	USB A/B,STP	1	0	2m	Y	[E]
13	[A] USB Host (bottom)	USB A/B,STP	1	1.2	2m	Y	[F]
14	[A] LAN	CAT5/5e/6,STP	1	7.6	100m	N	unterminated
15	[A] 19V IN	AC/DC adapter, UL1185	1	1.1	1.1m (to adapter)	Y	[G]
16	[A] Headset	headset	1	1.2	1.2m (to headset)	Y	[H]
17	[B] GNSS Antenna	Antenna integrated cable: 50Ω coaxial, RG-174/U,SMA	2	3m	3m	Y	[M] GNSS Antenna or [N] GPS ANTENNA
18	[B] 1PPS IN1	50Ω coaxial, RG-174/U,SMB	1	3m	7.5m	Y	unterminated
19	[B] 1PPS OUT	50Ω coaxial, RG-174/U,SMB	1	3m	7.5m	Y	[B] 1PPS IN2
20	[B] 10MHz OUT	50Ω coaxial, RG-174/U,SMB	1	3m	7.5m	Y	[B] 10MHz REF IN
21	[O] RF OUT	50Ω coaxial, RG-174/U,SMA	1	--	--	Y	[B] GNSS ANTENNA
22	[N] OUT C	50Ω coaxial, RG-58/U, BNC	1	--	--	--	[O] REF
23	[P] LAN	CAT5/5e/6,UTP	1	--	--	--	[Q] LAN1

Table 6. Ports and Cabling Information

H. Mode of Operation

The UUT will thus be running three simultaneous applications as denoted by the three separate tabs near the top of the display:

For emissions tests:

- “OTU4 111.8G Layer 2 Traffic Term” test application running on Port 1 (CFP4)
- “OTU4 111.8G Bulk BERT Term” test application running on Port 2 (QSFP)

For immunity tests:

- “10Gig Ethernet Layer 2 Traffic Term” test application running on Port 1 (SFP)
- “10Gig Ethernet Layer 2 Traffic Term” test application running on Port 2 (SFP)

For all tests:

- “Timing Module” timing application running on the attached C5TEM-R Expansion Module

For the purposes of simulating the EUT’s normal function of testing telecommunication circuits, the transmitted signals are looped back to the receivers using appropriate external, optical and/or electrical loopback cables.

The EUT and support equipment generally will remember their settings and will be delivered such that the correct tests are automatically started upon power-up. If verification is desired or problems are encountered during testing and it becomes apparent that the tests are not running properly:

To start the test on Port 1 (P1):

1. Select the appropriate test.

For emissions tests, select:

Select Test → OTN → OTU4 111.8G → Layer 2 Traffic → P1 Terminate.

For immunity tests, select:

Select Test → Ethernet → 10GigE LAN → Layer 2 Traffic → P1 Terminate.

2. With the Port 1 (P1) application tab selected:

For emissions tests only:

Select “CFP4” as the connector on the *Laser* tab.

Click the flashing *Laser Off* button on the *Laser* tab to turn the laser on.

Click the flashing *Start BERT Pattern* button on the *Actions* tab to start test traffic.

Clear any initial errors listed in the *Summary* window by pressing the *Restart* button.

To start the test on Port 2 (P2):

1. Select the appropriate test.

For emissions tests, select:

Select Test → Add Test → OTN → OTU4 111.8G → Layer 2 Traffic → P2 Terminate.

For immunity tests, select:

Select Test → Add Test → Ethernet → 10GigE LAN → Layer 2 Traffic → P2 Terminate.

2. With the Port 2 (P2) application tab selected:

Click the flashing *Laser Off* button on the *Laser* tab to turn the laser on.

For the emissions test only:

Click the flashing *Start BERT Pattern* button on the *Actions* tab to start test traffic.

Clear any initial errors listed in the *Summary* window by pressing the *Restart* button.

To start the Timing Module application:

The Timing Module application tab is presented automatically if the module is present when booted.

With the Timing Module tab selected, press *Setup* to select the correct proper configuration:

GPS → GNSS System = GPS

GPS → Antenna Type = Active

GPS → Antenna Power = 5 Volts (for emissions tests, with GPS antenna connected),

0 Volts (for immunity tests, with GPS simulator connected)

Location → Timing Mode = Survey

Location → Survey Mode = Typical

Oscillator/Timing → Sync Source = Internal GNSS

On the main results screen, if it is still off and flashing (note: the unit can be configured to turn it on automatically at power-up), click the *Rubidium Osc. On* button on the *Timing Module* tab to turn the oscillator on. For emissions tests (with GPS simulator disconnected), wait until Status = *Wait for 1PPS*. For immunity tests, wait until Status = *Coarse Tune, Intermediate Tune, or Fine Tune*. Note: The preceding *Warm Up, Wait for 1PPS* and *Initialization* states may take several minutes.

Clear any initial errors listed in the *Summary* window (if present) by pressing the *Restart* button. Note: The screen will stay red for emissions tests (with GPS simulator disconnected).

GPS simulator and external timing reference setup (for Immunity testing only):

To be configured by Viavi during witnessed testing.

To disable the EUT's wireless transmitters during EN 61326-1 emissions testing:

Select *System* → *Network* → *WiFi* to access the network configuration settings screen.

Uncheck the *Enable wireless adapter* checkbox.

Press *System* → *Bluetooth* to access the Bluetooth configuration settings screen.

Uncheck the *Enable Bluetooth* checkbox.

To enable the EUT's wireless transmitter during ETSI EN 301 489-1, 489-17 emissions and immunity testing:

Select *System* → *Network* → *WiFi* to access the network configuration settings screen.

Check the *Enable wireless adapter* checkbox.

Press *System* → *Bluetooth* to access the Bluetooth configuration settings screen.

Check the *Enable Bluetooth* checkbox.

I. Method of Monitoring EUT Operation

For test applications running on Port 1 and Port 2:

Each running test has its own full-screen test view that can be accessed by selecting the application tab for that particular test near the top of the screen. In full-screen mode, it is necessary to switch back and forth between the tabs in order to monitor each running test.

1. In normal error-free operation, the tab for the associated test is GREEN and, when selected:
 - the circular *Signal Present* indicator is GREEN
 - the circular *OTL Frame Sync* and/or *Sync Acquired* indicator is GREEN
 - the circular *OTL Lanes Aligned* indicator is GREEN
 - the circular *OTL Marker Lock* indicator is GREEN
 - the circular *Pattern Sync* or *L1 Pattern Sync* indicator is GREEN
 - the oval *Summary* indicator is GREEN
 - the text in both *Summary* results category windows states "ALL SUMMARY RESULTS OK"
 - the text below the test tabs states "RUNNING" and test minutes and seconds are incrementing
2. In Continuously Errored / Broken state you would see one or more of the following:
 - one or more circular indicators is not continuously GREEN
 - the text in either *Summary* results category windows is not GREEN, does not state "ALL SUMMARY RESULTS OK" and instead continuously displays one or more errors that do not have "HISTORY" in the error name and if the errors includes a count, is continuously incrementing.

For timing application running on the attached C5TEM Expansion Module:

1. In normal error-free operation, the tab for the associated test is either GREEN or YELLOW and, when selected:
 - the circular *GPS Time* indicator is GREEN
 - the circular *Antenna Fault* indicator is GRAY
 - the circular *Ref PPS Not Present* indicator is GRAY
 - the circular *PPS Freq Invalid* indicator is GRAY
 - Under result windows pull-down menus *GPS* → *Time*:
 - GPS Time Valid* = *Yes*
 - *GPS Time* seconds is incrementing
 - Under result windows pull-down menus *Oscillator* → *Status* or *Summary* → *Status*:
 - Oscillator Mode* = *Coarse Tune, Intermediate Tune, or Fine Tune*
 - LED adjacent to 1 PPS OUT connector is ON (blinking)

2. In Continuously Errored / Broken state you would see one or more of the following:
- the circular *GPS Time* indicator is RED
 - the circular *Antenna Fault* indicator is RED
 - the circular *Ref PPS Not Present* indicator is RED
 - the circular *PPS Freq Invalid* indicator is RED
 - Under either of the Port1 or Port 2 result windows:
 - the circular *ToD Sync* indicator is RED
 - the circular *IPPS Sync* indicator is RED
 - Under result windows pull-down menus *GPS* → *Time*:
 - *GPS Time Valid = No*
 - *GPS Time* seconds is not incrementing
 - Under result windows pull-down menus *Oscillator* → *Status* or *Summary* → *Status*:
 - Oscillator Mode* = stuck in any other state than *Coarse Tune*, *Intermediate Tune*, or *Fine Tune* for more than 20 min.
 - LED adjacent to 1 PPS OUT connector is ON (solid) or OFF

Note regarding immunity testing pass/fail criteria:

RED indicators alone do not necessarily constitute a failure per performance criteria B. For example, the *Summary* results box turns and remains RED after the first error is encountered, even if normal operation subsequently resumes. Also, if any of the square indicators turn RED, or an error is displayed that includes “HISTORY” in the error name, it means that at least one historical error of that type was registered. Provided that none of the conditions noted for Continuously Errored / Broken state are true, these historical-only errors are considered transient and signify that the equipment has resumed operating normally without user intervention. Proof that the EUT is still performing its function as a network tester can be had by manually inserting bit errors on the *Errors* tab. Errors can be cleared by selecting *Restart*.

J. Modifications

a) **Modifications to EUT**

No modifications were made to the EUT.

b) **Modifications to Test Standard**

No modifications were made to the test standard.

K. Disposition of EUT

The test sample including all support equipment submitted to the Electro-Magnetic Compatibility Lab for testing was returned to Viavi Solutions upon completion of testing.

III. Electromagnetic Compatibility Criteria for Intentional Radiators

Electromagnetic Compatibility Criteria for Intentional Radiators

§ 15.207(a) Conducted Emissions Limits

Test Requirement(s): § 15.207 (a): For an intentional radiator that is designed to be connected to the public utility (AC) power line, the radio frequency voltage that is conducted back onto the AC power line on any frequency or frequencies, within the band 150 kHz to 30MHz, shall not exceed the limits in the following table, as measured using a 50 μ H/50 Σ line impedance stabilization network (LISN). Compliance with the provisions of this paragraph shall be based on the measurement of the radio frequency voltage between each power line and ground at the power terminal. The lower limit applies at the boundary between the frequency ranges.

Frequency range (MHz)	§ 15.207(a), Conducted Limit (dB μ V)	
	Quasi-Peak	Average
* 0.15- 0.45	66 - 56	56 - 46
0.45 - 0.5	56	46
0.5 - 30	60	50

Table 7. Conducted Limits for Intentional Radiators from FCC Part 15 § 15.207(a)

Test Procedure: The EUT was placed on a 0.8 m-high wooden table inside a screen room. The EUT was situated such that the back of the EUT was 0.4 m from one wall of the vertical ground plane, and the remaining sides of the EUT were no closer than 0.8 m from any other conductive surface. The EUT was powered from a 50 Ω /50 μ H Line Impedance Stabilization Network (LISN). The EMC receiver scanned the frequency range from 150 kHz to 30 MHz. Conducted Emissions measurements were made in accordance with *ANSI C63.4-2003 "Methods and Measurements of Radio-Noise Emissions from Low-Voltage Electrical and Electronic Equipment in the Range of 9kHz to 40 GHz"*. The measurements were performed over the frequency range of 0.15 MHz to 30 MHz using a 50 Ω /50 μ H LISN as the input transducer to an EMC/field intensity meter. For the purpose of this testing, the transmitter was turned on. Scans were performed with the transmitter on.

Test Results: The EUT was compliant with this requirement. Measured emissions were below applicable limits.

Test Engineer(s): Jun Qi

Test Date(s): 12/22/2016

15.207(a) Conducted Emissions Test Results

Line	Freq (MHz)	QP Amplitude	QP Limit	Delta	Pass	Average Amplitude	Average Limit	Delta
Line	0.152045	52.18	65.888	-13.708	Pass	32.24	55.888	-23.648
Line	0.44039	45.81	57.079	-11.269	Pass	25.83	47.079	-21.249
Line	0.659205	43.74	56	-12.26	Pass	27.89	46	-18.11
Line	1.54878	39.08	56	-16.92	Pass	23.86	46	-22.14
Line	8.131635	43.12	60	-16.88	Pass	28.49	50	-21.51
Line	6.826925	36.11	60	-23.89	Pass	25.21	50	-24.79

Table 8. Conducted Emissions, 15.207(a), Phase Line, Test Results

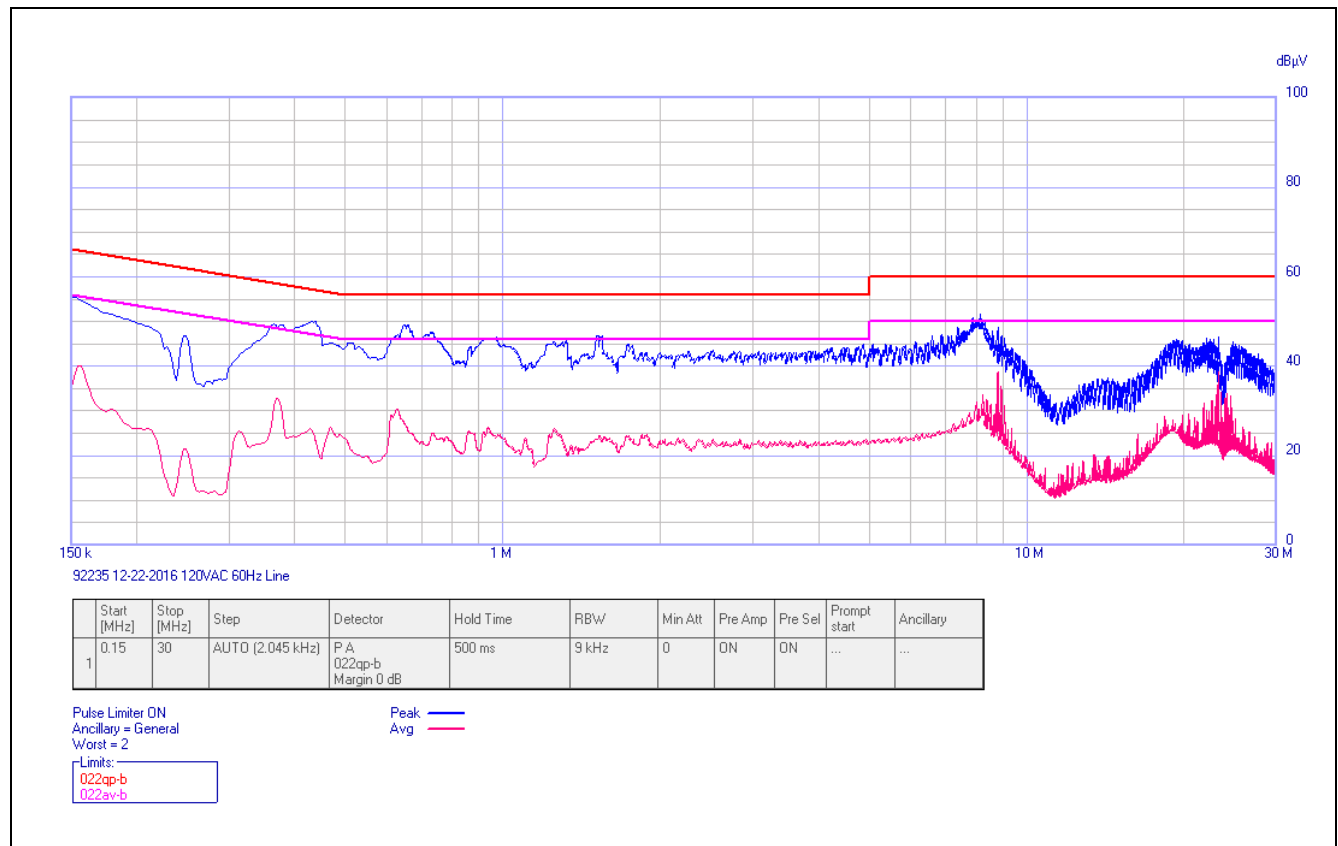

Plot 1. Conducted Emissions, 15.207(a), Phase Line

15.207(a) Conducted Emissions Test Results

Line	Freq (MHz)	QP Amplitude	QP Limit	Delta	Pass	Average Amplitude	Average Limit	Delta
Neutral	0.152045	42.12	65.888	-23.768	Pass	21.4	55.888	-34.488
Neutral	0.450615	44.47	56.888	-12.418	Pass	25.29	46.888	-21.598
Neutral	0.679655	41.86	56	-14.14	Pass	28.01	46	-17.99
Neutral	8.13368	44.07	60	-15.93	Pass	30.25	50	-19.75
Neutral	18.9824	35.41	60	-24.59	Pass	25.71	50	-24.29
Neutral	23.20329	31.16	60	-28.84	Pass	26.06	50	-23.94

Table 9. Conducted Emissions, 15.207(a), Neutral Line, Test Results

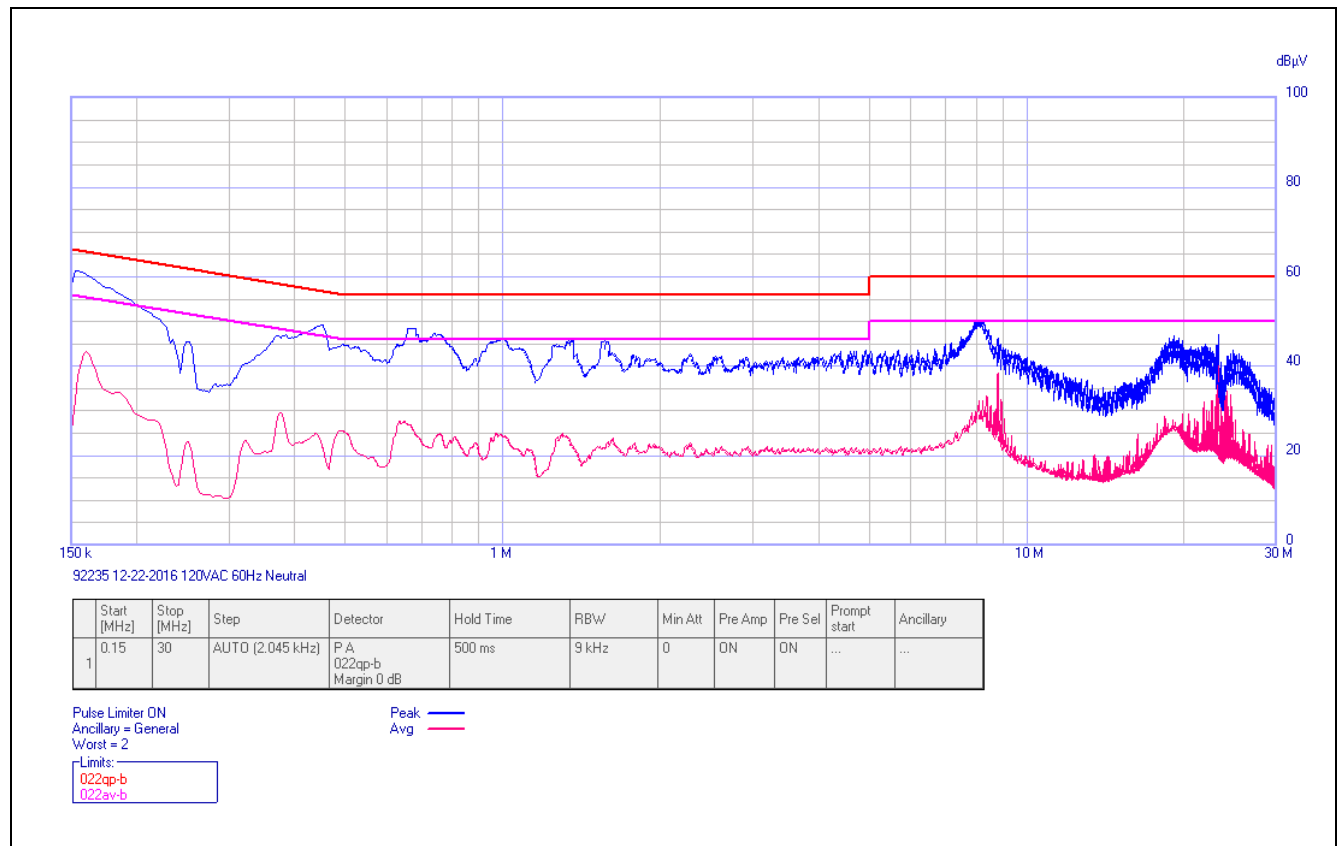

Plot 2. Conducted Emissions, 15.207(a), Neutral Line

15.207(a) Conducted Emissions Test Setup Photo

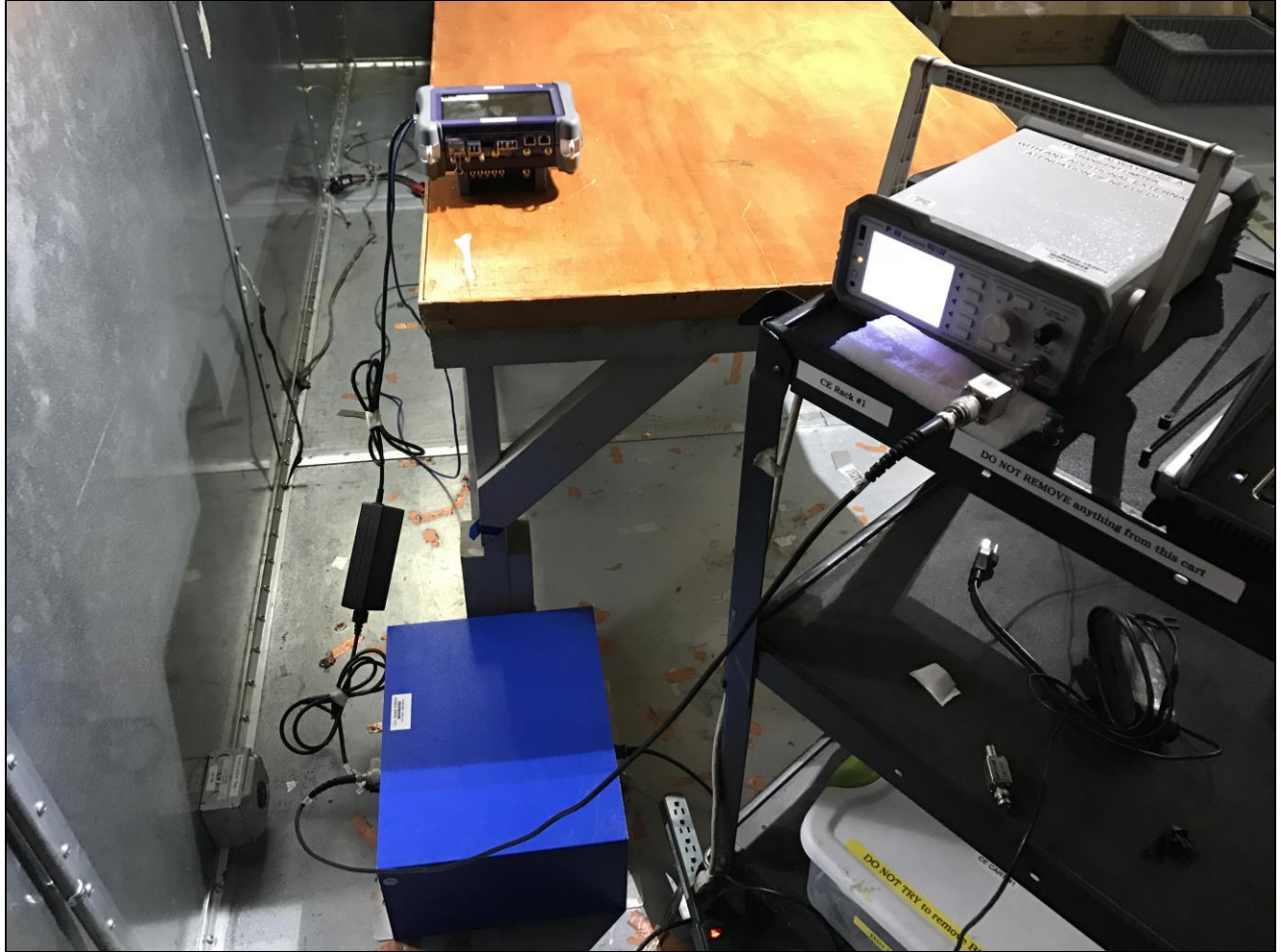

Photograph 2. Conducted Emissions, 15.207(a), Test Setup

IV. Test Equipment

Test Equipment

Calibrated test equipment utilized during testing was maintained in a current state of calibration per the requirements of ISO/IEC 17025:2005.

MET Asset #	Equipment	Manufacturer	Model	Last Cal Date	Cal Due Date
1S3809	EMI RECEIVER	NARDA SAFETY TEST SOLUTIONS	PMM 9010F	2/1/2016	2/1/2017
1S3913	SPIKEGUARD	FCC	FCC-450B-2.4-N	SEE NOTE	
1U0337	LISN	COM-POWER	LI-215A	5/31/2016	5/31/2017

Table 10. Test Equipment List

Note: Functionally tested equipment is verified using calibrated instrumentation at the time of testing.

V. Certification & User's Manual Information

Certification & User's Manual Information

A. Certification Information

The following is extracted from Title 47 of the Code of Federal Regulations, Part 2, Subpart I — Marketing of Radio frequency devices:

§ 2.801 Radio-frequency device defined.

As used in this part, a radio-frequency device is any device which in its operation is capable of Emitting radio-frequency energy by radiation, conduction, or other means. Radio- frequency devices include, but are not limited to:

- (a) The various types of radio communication transmitting devices described throughout this chapter.
- (b) *The incidental, unintentional and intentional radiators defined in Part 15 of this chapter.*
- (c) The industrial, scientific, and medical equipment described in Part 18 of this chapter.
- (d) Any part or component thereof which in use emits radio-frequency energy by radiation, conduction, or other means.

§ 2.803 Marketing of radio frequency devices prior to equipment authorization.

- (a) Except as provided elsewhere in this chapter, no person shall sell or lease, or offer for sale or lease (including advertising for sale or lease), or import, ship or distribute for the purpose of selling or leasing or offering for sale or lease, any radio frequency device unless:
 - (1) In the case of a device subject to certification, such device has been authorized by the Commission in accordance with the rules in this chapter and is properly identified and labeled as required by §2.925 and other relevant sections in this chapter; or
 - (2) In the case of a device that is not required to have a grant of equipment authorization issued by the Commission, but which must comply with the specified technical standards prior to use, such device also complies with all applicable administrative (including verification of the equipment or authorization under a Declaration of Conformity, where required), technical, labeling and identification requirements specified in this chapter.
- (d) Notwithstanding the provisions of paragraph (a) of this section, the offer for sale solely to business, commercial, industrial, scientific or medical users (but not an offer for sale to other parties or to end users located in a residential environment) of a radio frequency device that is in the conceptual, developmental, design or pre-production stage is permitted prior to equipment authorization or, for devices not subject to the equipment authorization requirements, prior to a determination of compliance with the applicable technical requirements *provided* that the prospective buyer is advised in writing at the time of the offer for sale that the equipment is subject to the FCC rules and that the equipment will comply with the appropriate rules before delivery to the buyer or to centers of distribution.

- (e)(1) Notwithstanding the provisions of paragraph (a) of this section, prior to equipment authorization or determination of compliance with the applicable technical requirements any radio frequency device may be operated, but not marketed, for the following purposes and under the following conditions:
- (i) *Compliance testing*;
 - (ii) Demonstrations at a trade show provided the notice contained in paragraph (c) of this section is displayed in a conspicuous location on, or immediately adjacent to, the device;
 - (iii) Demonstrations at an exhibition conducted at a business, commercial, industrial, scientific or medical location, but excluding locations in a residential environment, provided the notice contained in paragraphs (c) or (d) of this section, as appropriate, is displayed in a conspicuous location on, or immediately adjacent to, the device;
 - (iv) Evaluation of product performance and determination of customer acceptability, provided such operation takes place at the manufacturer's facilities during developmental, design or pre-production states; or
 - (v) Evaluation of product performance and determination of customer acceptability where customer acceptability of a radio frequency device cannot be determined at the manufacturer's facilities because of size or unique capability of the device, provided the device is operated at a business, commercial, industrial, scientific or medical user's site, but not at a residential site, during the development, design or pre-production stages.
- (e)(2) For the purpose of paragraphs (e)(1)(iv) and (e)(1)(v) of this section, the term *manufacturer's facilities* includes the facilities of the party responsible for compliance with the regulations and the manufacturer's premises, as well as the facilities of other entities working under the authorization of the responsible party in connection with the development and manufacture, but not the marketing, of the equipment.
- (f) For radio frequency devices subject to verification and sold solely to business, commercial, industrial, scientific and medical users (excluding products sold to other parties or for operation in a residential environment), parties responsible for verification of the devices shall have the option of ensuring compliance with the applicable technical specifications of this chapter at each end user's location after installation, provided that the purchase or lease agreement includes a proviso that such a determination of compliance be made and is the responsibility of the party responsible for verification of the equipment.

Certification & User's Manual Information

The following is extracted from Title 47 of the Code of Federal Regulations, Part 2, Subpart J — Equipment Authorization Procedures:

§ 2.901 Basis and Purpose

- (a) In order to carry out its responsibilities under the Communications Act and the various treaties and international regulations, and in order to promote efficient use of the radio spectrum, the Commission has developed technical standards for radio frequency equipment and parts or components thereof. The technical standards applicable to individual types of equipment are found in that part of the rules governing the service wherein the equipment is to be operated.¹ *In addition to the technical standards provided, the rules governing the service may require that such equipment be verified by the manufacturer or importer, be authorized under a Declaration of Conformity, or receive an equipment authorization from the Commission by one of the following procedures: certification or registration.*
- (b) The following sections describe the verification procedure, the procedure for a Declaration of Conformity, and the procedures to be followed in obtaining certification from the Commission and the conditions attendant to such a grant.

§ 2.907 Certification.

- (a) Certification is an equipment authorization issued by the Commission, based on representation and test data submitted by the applicant.
- (b) Certification attaches to all units subsequently marketed by the grantee which are identical (see Section 2.908) to the sample tested except for permissive changes or other variations authorized by the Commission pursuant to Section 2.1043.

¹ In this case, the equipment is subject to the rules of Part 15. More specifically, the equipment falls under Subpart B (of Part 15), which deals with unintentional radiators.

Certification & User's Manual Information

§ 2.948 Description of measurement facilities.

- (a) Each party making measurements of equipment that is subject to an equipment authorization under Part 15 or Part 18 of this chapter, regardless of whether the measurements are filed with the Commission or kept on file by the party responsible for compliance of equipment marketed within the U.S. or its possessions, shall compile a description of the measurement facilities employed.
- (1) If the measured equipment is subject to the verification procedure, the description of the measurement facilities shall be retained by the party responsible for verification of the equipment.
- (i) *If the equipment is verified through measurements performed by an independent laboratory, it is acceptable for the party responsible for verification of the equipment to rely upon the description of the measurement facilities retained by or placed on file with the Commission by that laboratory. In this situation, the party responsible for the verification of the equipment is not required to retain a duplicate copy of the description of the measurement facilities.*
- (ii) If the equipment is verified based on measurements performed at the installation site of the equipment, no specific site calibration data is required. It is acceptable to retain the description of the measurement facilities at the site at which the measurements were performed.
- (2) If the equipment is to be authorized by the Commission under the certification procedure, the description of the measurement facilities shall be filed with the Commission's Laboratory in Columbia, Maryland. The data describing the measurement facilities need only be filed once but must be updated as changes are made to the measurement facilities or as otherwise described in this section. At least every three years, the organization responsible for filing the data with the Commission shall certify that the data on file is current.

Certification & User's Manual Information

1. Label and User's Manual Information

The following is extracted from Title 47 of the Code of Federal Regulations, Part 15, Subpart A — General:

§ 15.19 Labeling requirements.

(a) *In addition to the requirements in Part 2 of this chapter, a device subject to certification or verification shall be labeled as follows:*

- (1) Receivers associated with the operation of a licensed radio service, e.g., FM broadcast under Part 73 of this chapter, land mobile operation under Part 90, etc., shall bear the following statement in a conspicuous location on the device:

This device complies with Part 15 of the FCC Rules. Operation is subject to the condition that this device does not cause harmful interference.

- (2) A stand-alone cable input selector switch, shall bear the following statement in a conspicuous location on the device:

This device is verified to comply with Part 15 of the FCC Rules for use with cable television service.

- (3) All other devices shall bear the following statement in a conspicuous location on the device:

This device complies with Part 15 of the FCC Rules. Operation is subject to the following two conditions: (1) This device may not cause harmful interference, and (2) this device must accept any interference received, including interference that may cause undesired operation.

- (4) Where a device is constructed in two or more sections connected by wires and marketed together, the statement specified under paragraph (a) of this section is required to be affixed only to the main control unit.

- (5) When the device is so small or for such use that it is not practicable to place the statement specified under paragraph (a) of this section on it, the information required by this paragraph shall be placed in a prominent location in the instruction manual or pamphlet supplied to the user or, alternatively, shall be placed on the container in which the device is marketed. However, the FCC identifier or the unique identifier, as appropriate, must be displayed on the device.

§ 15.21 Information to user.

The user's manual or instruction manual for an intentional or unintentional radiator shall caution the user that changes or modifications not expressly approved by the party responsible for compliance could void the user's authority to operate the equipment.

Verification & User's Manual Information

The following is extracted from Title 47 of the Code of Federal Regulations, Part 15, Subpart B — Unintentional Radiators:

§ 15.105 Information to the user.

- (a) For a Class A digital device or peripheral, the instructions furnished the user shall include the following or similar statement, placed in a prominent location in the text of the manual:

Note: This equipment has been tested and found to comply with the limits for a Class A digital device, pursuant to Part 15 of the FCC Rules. These limits are designed to provide reasonable protection against harmful interference when the equipment is operated in a commercial environment. This equipment generates, uses, and can radiate radio frequency energy and, if not installed and used in accordance with the instruction manual, may cause harmful interference to radio communications. Operation of this equipment in a residential area is likely to cause harmful interference in which case the user will be required to correct the interference at own expense.

- (b) For a Class B digital device or peripheral, the instructions furnished the user shall include the following or similar statement, placed in a prominent location in the text of the manual:

Note: This equipment has been tested and found to comply with the limits for a Class B digital device, pursuant to Part 15 of the FCC Rules. These limits are designed to provide reasonable protection against harmful interference when the equipment is operated in a residential environment. This equipment generates, uses, and can radiate radio frequency energy and, if not installed and used in accordance with the instruction manual, may cause harmful interference to radio communications. However, there is no guarantee that interference will not occur in a particular installation. If this equipment does cause harmful interference to radio or television reception, which can be determined by turning the equipment off and on, the user is encouraged to try to correct the interference by one or more of the following measures:

- Reorient or relocate the receiving antenna.
- Increase the separation between the equipment and receiver.
- Connect the equipment into an outlet on a circuit different from that to which the receiver is connected.
- Consult the dealer or an experienced radio/TV technician for help.

ICES-003 Procedural & Labeling Requirements

From the Industry Canada Electromagnetic Compatibility Advisory Bulletin entitled, "Implementation and Interpretation of the Interference-Causing Equipment Standard for Digital Apparatus, ICES-003" (EMCAB-3, Issue 2, July 1995):

"At present, CISPR 22: 2002 and ICES technical requirements are essentially equivalent. Therefore, if you have CISPR 22: 2002 approval by meeting CISPR Publication 22, the only additional requirements are: to attach a note to the report of the test results for compliance, indicating that these results are deemed satisfactory evidence of compliance with ICES-003 of the Canadian Interference-Causing Equipment Regulations; to maintain these records on file for the requisite five year period; and to provide the device with a notice of compliance in accordance with ICES-003."

Procedural Requirements:

According to Industry Canada's Interference Causing Equipment Standard for Digital Apparatus ICES-003 Issue 5 August 2012:

- Section 6.1: A record of the measurements and results, showing the date that the measurements were completed, shall be retained by the manufacturer or importer for a period of at least five years from the date shown in the record and made available for examination on the request of the Minister.
- Section 6.2: A written notice indicating compliance must accompany each unit of digital apparatus to the end user. The notice shall be in the form of a label that is affixed to the apparatus. Where because of insufficient space or other constraints it is not feasible to affix a label to the apparatus, the notice may be in the form of a statement in the users' manual.

Labeling Requirements:

The suggested text for the notice, in English and in French, is provided below, from the Annex of ICES-003:

This Class [²] digital apparatus complies with Canadian ICES-003.

Cet appareil numérique de la classe [¹] est conforme à la norme NMB-003 du Canada.

² Insert either A or B but not both as appropriate for the equipment requirements.

End of Report