

# Video Light APP Module

## JDY-25M Bluetooth Module Manual

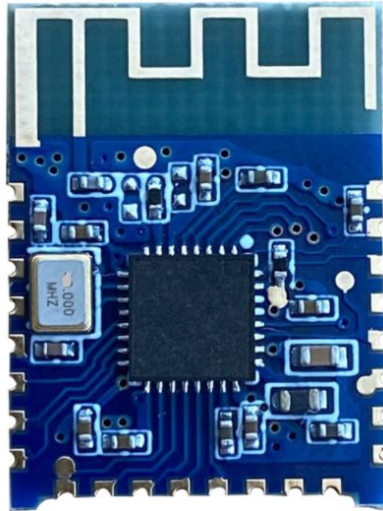

## JDY-25M **Super BLE** Bluetooth Module

---

### Version

<b>Versi on</b>	<b>Date</b>	<b>Description</b>
V1.72	20200725	Release version

## I . Product introduction

JDY-25M super Bluetooth function supports master-slave transparent transmission, iBeacon, BLE probe, iBeacon detection, and MESH network. The maximum number of MESH network supports 65280 device network. Multi-hop wireless anti-collision technology is adopted. The network communication speed supports 50ms to send 16 byte data. The single module supports routing node and terminal node. The routing node supports data relay (low power consumption is not supported). The terminal node supports low power consumption (automatic sleep after key wake-up and data sending), JDY-25M network generally only needs to be configured with network NETID and short address, and the module will automatically network. When the network module communicates with APP, it is equivalent to transparent transmission, which greatly convenient for users to develop APP compatible with old products APP.

## II . Product characteristics

- 1: Support data transparent transmission with mobile phone (IOS, Android) APP (working current about 1mA)
- 2: Support module and module master slave high speed transparent transmission
- 3: Support iBeacon function (ultra-low power consumption)
- 4: Support iBeacon probe function
- 5: Support BLE Bluetooth probe function
- 6: Multi-connected slave mode is supported. Multi-connected slave can connect with multiple mobile phones and transparent transmission at the same time.
- 7: Support Bluetooth MESH network (Network serial port data communication, output IO control, input key control)
- 8: MESH network data sending supports response and no response communication
- 9: Network remote control
- 10: Multi-connected master-slave mixed connection (the master is connected to the slave at the same time, and the slave is connected to the mobile phone at the same time, and work at the same time)

## III. Product application scope

- 1: Bluetooth network LED (one-to-many, many-to-one, mobile phone or remote controller control, many-to-many control)
- 2: Bluetooth network serial port communication application (one-to-many, many-to-one, mobile phone or remote controller control, many-to-many control)
- 3: Network panel switch, 86 switch (ultra-low power consumption)
- 4: Network smart home application (switch, relay, curtain) control
- 5: Network sensor application
- 6: WIFI network gateway application
- 7: Zigbee network application
- 8: Mobile network control application
- 9: Key label

**IV. Technical specifications:**

Type		Specification parameter
Working voltage		1.9 – 3.6V
Working temperature		-40 - 85°C
Maximum transmitting power		+4dbm
Communication distance		80m
Bluetooth version		BLE5.0
Antenna		PCB antenna
Antenna gain		-0.58dbi
Receiving sensitivity		-96dbm
SMT welding temperature		<260°C
Communication interface		UART
Module size		27mm * 12.88 * 1.6
<b>Communication speed between slave and APP</b>		<b>8k(byte/s)</b>
<b>MESH communication speed</b>		<b>50ms send 16byte</b>
Average current	Wake up (transparent transmission) current in non MESH mode	About 1mA
	Light sleep of slave with broadcast in non MESH mode	Within 200uA (related to broadcasting interval)
	Wake up communication current in MESH mode	About 4mA
	Sleep current in MESH mode	3uA
	Deep Sleep Mode	3uA

**V. Factory default configuration:**

No.	Function	Parameter	AT instructions
1	Baud rate	9600	AT+BAUD4
2	Module short address	Last 2 bytes of MAC address	
3	Network ID	1189	AT+NETID1189
4	K1 target short address	FFFF	AT+KEY1,FFFF,1,1
5	K2 target short address	FFFF	AT+KEY2,FFFF,2,1
6	K3 target short address	FFFF	AT+KEY3,FFFF,3,1
7	K4 target short address	FFFF	AT+KEY4,FFFF,4,1
8	K5 target short address	FFFF	AT+KEY5,FFFF,5,1
9	APP connection password switch	OFF	AT+TYPE0
10	APP connection password	123456	AT+PIN123456
11	Broadcast name	JDY-25M	AT+NAMEJDY-25M

## JDY-25M **Super BLE** Bluetooth Module

---

12	Router node	0	AT+MCLSS0
13	Transmitting power	4	AT+POWR4
14	OUTPUT and INPUT unrelated	0	AT+SUBTYPE0
15	Learn mode off	0	AT+LEARN0

Special instruction: V1.5 default that factory setting of K1 to K5 is not 0, so the customer is misled that all key values are the same.

Example: If it needs K1 to control the OUTPUT1 level of all devices in the network, use the default parameters.

If it needs K1 to control only the OUTPUT1 level of 0008 target address, it is required to set K1 target short address to 0008, complete instruction (AT+KEY1,0008,1,1)

Of course, K1 may not only control IO of the target device OUTPUT1

Example: K1 control target 0008 device OUTPUT2 level, complete instruction (AT+KEY1,0008,2,1)

If you need to synchronize the OUTPUT of the current device with the target device level of the KEY button, you need to open this command: AT+SUBTYPE1

When the SUBTYPE is set to 1, the OUTPUT pin of the current device will be synchronized with the remote device level controlled by the KEY button,

For example, when KEY1 is pressed, its own OUTPUT1 will also output the level, and the remote device OUTPUT pin will also output the level. KEY2, KEY3, KEY4 and KEY5 will also be synchronized with its own OUTPUT2, OUTPUT3, OUTPUT4 and OUTPUT5.

The default value of SUBTYPE is 0. The function is that the OUTPUT pin level is not associated with the output level of the target device of the current KEY. Both OUTPUT and KEY are independent functions. KEY can control the target device and OUTPUT can also be controlled by the remote device. Both are completely independent.

Two JDY-25M devices, one as a **Learner** and the other as a **Code sender**

The following is the function description of KEY and OUTPUT pin learning. In the learn mode, the parameters configured by AT+KEY instruction are invalid. Only by learning or AT+LEAVAL can the parameters configured by KEY button be valid.

1. Learn mode requires sending AT+LEARN1 instruction to open
2. It needs to associate OUTPUT with KEY, and send AT+SUBTYPE1 to open

After the above configuration, the KEY button and the OUTPUT pin of the remote device can be freely configured through learning.

### **Method 1: AT instruction configuration**

Example 1: Remote 0008 device KEY1 controls the OUTPUT1 and OUTPUT2 levels of the current device at the same time

Current device sends instruction: AT+LEAVAL1,1,0008  
AT+LEAVAL2,1,0008

Example 2: Remote 0008 device KEY2 controls the current device's OUTPUT5 level

Current device sends instruction: AT+LEAVAL5,2,0008

## JDY-25M **Super BLE** Bluetooth Module

---

### Method 2: Key Learning

1. Enter **Learner** mode: Double-click the PWRC pin, and the STAT light will flash slowly, and the LED light of the ALED pin will be off to indicate that it has entered the **Learner**. In the learning state, if the OUTPUT pin does not learn the key value, it will flash once a second. When the code sent by the **Code sender** is received, it will be always on, indicating that the key value has been learned. When the KEY1-KEY5 pin of **Learner** is not pressed in the learning state, it means that the learned key value of **Learner** OUTPUT1 to OUTPUT5 corresponds to the KEY1 to KEY5 of **Code sender**, that is to say, **Learner** OUTPUT1 can only be controlled by the KEY1 of **Code sender**, and of course, it also supports free learning.

Free learning method:

Example 1: The binding method of OUTPUT1 of **Learner** to KEY5 of **Code sender**:

Double-click the PWRC pin of **Learner** to enter the learn mode, and then press the KEY1 pin of **Learner** to enter the learning state of **Learner** OUTPUT1, so that **Learner** OUTPUT1 can freely learn the key values of **Code sender** KEY1 to KEY5. Press **Code sender** KEY5, and **Learner** OUTPUT1 will learn the KEY5 value of **Code sender**, so that **Code sender** KEY5 will be able to control the OUTPUT1 pin level of **Learner**.

2. Enter **Code sender** mode: Click PWRC pin, and the LED light of STAT pin off, and the LED light of ALED pin flashes slowly, indicating that it has entered **Code sender**. Then press KEY1-KEY5, and **Learner** will learn the key value sent by **Code sender**.

Quit **Learner** mode: Double-click the PWRC pin, and the ALED light will flash quickly (once a second). Only after quitting the learn mode can the learned parameters work normally.

3. Quit **Code sender** mode: Click the PWRC pin, and the ALED pin flashes quickly( once a second). The KEY1-KEY5 will take effect only after quitting the **Code sender** mode.

### In particular, the mode can be distinguished by LED flashing:

**Learner**: The LED light of the STAT pin flashes slowly, and the LED light of the LEED pin is off, indicating that it enters the **Learner** mode. In the **Learner** mode, the OUTPUT pin flashes, indicating that the pin is in the learning state, and if it light constantly means the code has been learned.

**Code sender**: The LED light of STAT pin is off, and the ALED pin flashes slowly, indicating that it has entered the **Code sender** mode. In the **Code sender** mode, press the INPUT button, and the corresponding OUTPUT will be high level.

**Normal work**: LED of ALED pin flashes quickly(once a second), if there is a central machine, the STAT pin is on constantly, indicating normal work.

Key learning is generally used in the case of no APP or serial port configuration. If there is APP or serial port configuration, it is easier to use.

## VI. Module pin definition

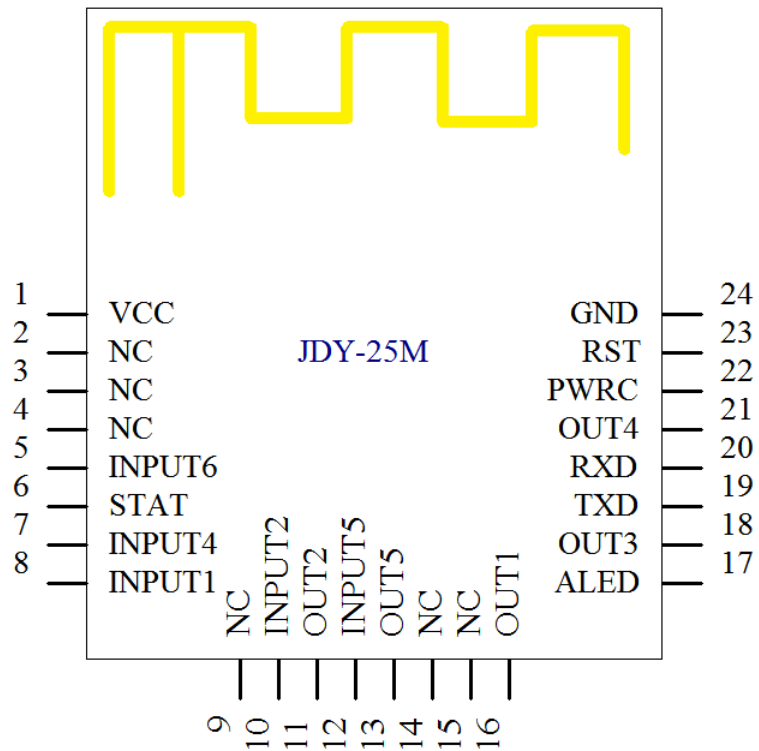

Note: The general transport transmission application only needs to connect 4 pins of VCC, GND, RXD and TXD.

## VII. Pin function description

Pin	Definition	Function	Description
1	TXD	Serial port	Serial output, the level is TTL level
2	RXD	Serial port	Serial input, the level is TTL level
3	NULL	Null	-
4	NULL	Null	-
5	KEY5	Input 5	In mesh mode, press the key to control the IO level of the specified device
6	KEY4	Input 4	In mesh mode, press the key to control the IO level of the specified device
7	KEY3	Input 3	In mesh mode, press the key to control the IO level of the specified device
8	KEY2	Input 2	In mesh mode, press the key to control the IO level of the specified device
9	NULL	Null	-
10	KEY1	Input 1	In mesh mode, press the key to control the IO level of the specified device
11	RESET	Reset	Low level reset, high level working (high level if suspended)
12	VCC	Power Supply	Supply (1.8-3.6V)
13	GND	GND	Power ground
14	PWRC	Sleep wake pin	Support PWRC pin wake-up in deep sleep state, and AT instruction sending is supported when the connection status is pulled down
15	ALED	Broadcast LED indication	In non mesh mode (flash if not connected, light on after connection)
16	STAT	Connection status	In non mesh mode, low level if not connected, high level after connection In mesh mode (output high level if connect to network successfully, if not, output low level)
17	OUTPUT5	Output 5	Default low level, support serial instruction control and input KEY pin control in network state
18	NULL	Null	-
19	NULL	Null	-
20	NULL	Null	-
21	NULL	Null	-
22	OUTPUT1	Output 1	Default low level, support serial instruction control and input KEY pin control in network state
23	OUTPUT2	Output 2	Default low level, support serial instruction control and input KEY pin control in network state
24	OUTPUT3	Output 3	Default low level, support serial instruction control and input KEY pin control in network state



## JDY-25M **Super BLE** Bluetooth Module

---

25	OUTPUT4	Output 4	Default low level, support serial instruction control and input KEY pin control in network state
----	---------	----------	--

### VIII. Serial port AT instruction set

AT instruction sent by JDY-25M module serial port must add \r\n

No.	Instruction	Function	Default
1	AT	Test instruction	-
2	AT+RESET	Reset	-
3	AT+VERSION	Firmware version	-
4	AT+LADDR	Read MAC address	-
5	AT+NAME	Broadcast name read and write	JDY-25M
6	AT+PIN	Connection password setting	123456
7	AT+TYPE	Whether to open password connection mode	0
8	AT+BAUD	Baud rate	115200
9	AT+DISC	Disconnect	-
10	AT+STAT	Read connection status	0
11	AT+STARTEN	Power on sleep setting	1
12	AT+ADVINT	Broadcast interval	1
13	AT+POWR	Transmitting power	3
14	AT+ROLE	Working mode setting	0
15	AT+SLEEP	Sleep instruction	-
16	AT+DEFAULT	Restore factory configuration	-
17	AT+INQ	Master search slave broadcast	-
18	AT+STOP	Stop broadcasting	-
19	AT+CONN	Connect scan list ID number	-
20	AT+CONA	Instruction MAC address connection	-
21	AT+BAND	Bind slave MAC address	-

## JDY-25M **Super BLE** Bluetooth Module

22	AT+CLRBAND	Clear binding	-
23	AT+SRBAND	Connect the strongest signal slave nearby	-
24	AT+MESH	MESH sends data	-
25	AT+KEY	Key parameter configuration	-
26	AT+NETID	Network ID number configuration	1189
27	AT+MADDR	Network short address	Last two digits of MAC address
28	AT+MCLSS	Type of network device	0 (Router)
29	AT+FRIEND	Add private friend MAC address	000000000000
30	AT+CLRFRIEND	Clear friend	
31	AT+FRTYPE	Friend type	0
32	AT+IBUUID	UUID configuration of iBeacon	
33	AT+MAJOR	MAJOR configuration of iBeacon	000A
34	AT+MINOR	MINOR configuration of iBeacon	0007
35	AT+IBSING	SING configuration of iBeacon	
36	AT+ENLOG	Serial port output status switch	1 (On)
37	AT+DATA	Data instructions sent by slave multiple connections	
38	AT+CUIO	Serial port setting current module output IO level	
39	AT+TGIO	Master controls the output IO level of slave when the master	

## JDY-25M **Super BLE** Bluetooth Module

		communicates	
40	AT+FUNC	Master sets slave wireless parameters	
41	AT+SUBTYPE	Subtype (routing mode is valid)	0
42	AT+LEARN	Learn switch	0
43	AT+LEAVAL	Output IO learn parameters	0,0,0000
44	AT+DEVCLSS	For one key connection of the master to the strongest signal slave nearby	0
45	AT+KLABEL	Add label address (10 Tags supported)	0,0,000000000000
46	AT+KLTIME	Set label overtime time	3s
47	AT+KLRSSI	Set label sensitivity (For receiving range setting)	99

### 1、Test instruction

Instruction	Response	Parameter
AT	+OK	NULL

### 2、Reset

Instruction	Response	Parameter
AT+RESET	+OK	NULL

### 3、Query - software version number

Instruction	Response	Parameter
AT+VERSION	+VERSION=JDY-25M-V1.72	NULL

### 4、Query - Bluetooth MAC address

Instruction	Response	Parameter
-------------	----------	-----------

## JDY-25M **Super BLE** Bluetooth Module

AT+LADDR	+LADDR=<Param>	Param: MAC address hex character string
----------	----------------	---

### 5、Set/query - BLE broadcast name

Instruction	Response	Parameter
AT+NAME<Param>	+OK	Param: BLE broadcast name Max: 18 byte
AT+NAME	+NAME=<Param>	Default broadcast name: JDY-25M

### 6、Set/query - BLE Bluetooth pairing password

Instruction	Response	Parameter
AT+PIN<Param>	+OK	Param: 4 bit password
AT+PIN	+PIN=<Param>	Default PIN: 123456

### 7、Set/query - BLE Bluetooth password connection mode

Instruction	Response	Parameter
AT+TYPE<Param>	+OK	Param(0-2) 0: No password for connection 1: Password connection and not binding 2: Password connection and binding Default: 0
AT+TYPE	+TYPE=<Param>	

Instruction: Not bind the password connection. The function is to input the password every time the mobile phone is connected to the module.

Bind password connection. The function is that you only need to enter the password once when connecting to the mobile phone, and the password is no longer needed for later connection

**Special instruction: When master slave transparent transmission, if the slave is configured with a password connection, the master also needs to be configured with the same password to connect, otherwise the master will not be able to connect to the slave.**

### 8、Set/query - Baud rate

Instruction	Response	Parameter
AT+BAUD<Param>	+OK	Param:(2 to 8) 2: 2400 3: 4800 4: 9600
AT+BAUD	+BAUD=<Param>	5: 19200 6: 38400 7: 57600 8: 115200 Default: 8

### 9、Disconnect

Instruction	Response	Parameter
AT+DISC	+OK	NULL

Instruction: In the connection state, send the AT+DISC instruction to disconnect the Bluetooth connection by pulling down the PWRC pin.

### 10、Query - connection status

Instruction	Response	Parameter
AT+STAT	+STAT=<Param>	Param(0-3) 0: Unconnected 1: Connected 2: Networked 3: Connected and networked

Note: MESH status is valid only when there is a central machine in the network. **In particular, when there is a large number of networks, users are not recommended to open the central machine to cause network load.**

## JDY-25M **Super BLE** Bluetooth Module

### 11、Set/query - Power on sleep or wake-up

Instruction	Response	Parameter
AT+STARTEN<Param>	+OK	Param: (0-1) 1: Power on wake-up, sleep can be controlled through AT+SLEEP
AT+STARTEN	+STARTEN:<Param>	0: Power on sleep, connect wake-up, disconnect sleep Default: 1

Instruction: The power on sleep instruction can only be set in slave mode, other modes are invalid.

### 12、Set/query - Broadcast interval

Instruction	Response	Parameter
AT+ADVINT<Param>	+OK	Param: (0-9) 1: 100ms 2: 200ms 3: 300ms 4: 500ms 5: 700ms 6: 1000ms 7: 1500ms 8: 3000ms 9: 6000ms Default: 1
AT+ADVINT	+ADVINT:<Param>	

### 13、Set/query - Transmitting power

Instruction	Response	Parameter
AT+POWR<Param>	+OK	Param: (0-8) 0: -15dbm 1: -0dbm 2: 2dbm 3: 3dbm 4: 4dbm Default: 4
AT+POWR	+POWR=<Param>	

### 14、Set/query - Module working mode

Instruction	Response	Parameter
AT+ROLE<Param>	OK	Param: (0-8) 0: Transparent transmission of slave (APP, Wechat, applet) 1: Master transparent transmission mode 2: BLE broadcast probe module
AT+ROLE	+ROLE=<Param>	

## JDY-25M **Super BLE** Bluetooth Module

		3: iBeacon mode 4: iBeacon probe mode 5: MESH network mode 6: Multi-connected slave mode (supports 4 master connections) 7: Multi-connected master-slave (the master supports to connect 4 slaves at the same time, and the slave supports to connect 4 masters) 8: Key label detection mode (when the bound label approaches, IO of JDY-25M will act) Default: 5
--	--	---

**IBEACON probe mode output data format is as follows:**

54 58 44 ea d8 f1 b5 a2 52 fd a5 06 93 a4 e2 4f b1 af cf c6 eb 07 64 78 25 00 0a 00 07 0d 0a  
 TX MAC RSSI iBeacon UUID Major Minor  
 End

### 15、Set/query - Sleep instruction

Instruction	Response	Parameter
AT+SLEEP<Param>	+SLEEP:OK	Param: (1-2)
AT+SLEEP		1: Light sleep ( <b>with broadcast</b> ) 2: Deep sleep ( <b>without broadcast</b> )

Instruction: Only AT+SLEEP2 instruction is supported in MESH mode, and AT+SLEEP or AT+SLEEP1 instruction is supported in other modes.

### 16、Set - Restore factory configuration (Restore to factory default configuration parameters)

Instruction	Response	Parameter
AT+DEFAULT	+OK	NULL

### 17、Set - Master scan

Instruction	Response	Parameter
AT+INQ<Param>	OK	Param: (1-2)
AT+INQ	OK	0: Search stops after 2 seconds 1: Search stops after 4 seconds 2: Search stops after 6 seconds 3: Search stops after 8 seconds 4: Search stops after 16 seconds Default: 0 second

Example: +DEV:1=1893D711AB87,-82,JDY-08 MAC, RSSI and device name are returned when the master scans the slave

## JDY-25M **Super BLE** Bluetooth Module

---

### 18、Set - Stop scanning

Instruction	Response	Parameter
AT+STOP	OK	NULL

If the user needs MCU to control the scan stop, it is generally recommended to set the search device to 4 and the instruction is AT+INQ4 when scanning the device, so that the MCU can send the instruction to stop the scan within this time, of course, it will automatically stop when the time is up.

### 19、Search list connection

Instruction	Response	Parameter
AT+CONN <Param>	OK	Param: (0-7)
AT+CONN	+CONN=<Param>	

Example: AT+CONN1

### 20、Specify MAC address connection

Instruction	Response	Parameter
AT+CONA	+CONN=<Param>	Param: (MAC hex character string)

Example: AT+CONA112233445566

### 21、Set/query - Master binds MAC address

Instruction	Response	Parameter
AT+BAND<Param>	OK	Param: (MAC hex character string)
AT+BAND	+BAND=<Param>	

Example: AT+BAND112233445566

### 22、Set - Master unbind

Instruction	Response	Parameter
AT+CLRBAND	OK	NULL

### 23、Set - Master search the strongest signal slave nearby and bind and connect automatically

Instruction	Response	Parameter
AT+SRBAND	OK	NULL

### 24、Set - MESH sends data

Instruction	Response	Parameter
AT+MESH<Param>	OK	Param: (hex data)

Example: **41 54 2b 4d 45 53 48** 00 ff ff 11 22 33 0d 0a

Instruction: The red part (**41 54 2b 4d 45 53 48**) is hexadecimal data of AT+MESH. The example function is to send broadcast data to all devices in the target network. The broadcast data content is: 11 22 33



## JDY-25M **Super BLE** Bluetooth Module

As there are too many functions of MESH network, it will not be described in detail in this document. Please refer to the document of *Instructions for use of mesh. PDF*.

### 25、Set/query - Key input pin function

Instruction	Response	Parameter
AT+KEY<Param1>, <Param2>, <Param3>, <Param4>	OK	Param1: Indicates input IO number (1-5) Param2: Target address(0000 to ffff) Param3: Target output IO number (1-5)
AT+KEY<Param1>	+KEY=<Param1>, <Param2>, <Param3>, <Param4>	Param4: Whether the target device prints output (0-1) from the serial port at the same time after receiving the instruction, 0 means no serial port output, 1 means simultaneous serial port output

### 26、Set/query - MESH network ID number

Instruction	Response	Parameter
AT+NETID<Param1>	OK	Param1: (0000 to FFFF)
AT+NETID	+NETID=<Param1>	

**Instruction:** The ID number of the network within the same network must be the same, otherwise the network cannot be established.

### 27、Set/query - MESH short address

Instruction	Response	Parameter
AT+MADDR<Param1>	OK	Param1: (0001 to FFFF)
AT+MADDR	+MADDR=<Param1>	

**Instruction:** The function of the short address in the network is the unique ID number of each device. The same short address cannot appear in the same network. The short address is configured by AT instruction, and it can also be automatically assigned. To automatically assign the address, you need to turn on the central machine, and automatically assign the ID to the device that enters the network for the first time through the central machine. It is generally recommended that the user configure the short address by AT instruction himself.

### 28、Set/query - Mesh network device type

Instruction	Response	Parameter
AT+MCLSS<Param1>	OK	Param1: (0-1) 0: Router (supports relaying) 1: Terminal device (without relay function)
AT+MCLSS	+MCLSS=<Param1>	

**Instruction:** Router supports data relay, not low power consumption

## JDY-25M **Super BLE** Bluetooth Module

The terminal settings should be applied to low-power consumption network device. The default is power on sleep. Data will be sent after key wake-up and sleep will be immediately after sending.

### 29、 Add / query - MESH friend MAC address

Response	Parameter
OK	Param1: (MAC address hex byte string)
+FRIEND=<Param1>	Default: 000000000000

### 30、 Clear -MESH friend MAC address

Instruction	Response	Parameter
AT+CLRFRIEND	OK	

### 31、 Set/query - MESH friend type

Instruction	Response	Parameter
AT+FRTYPE<Param1>	OK	Param1: (0 or 1)
AT+FRTYPE	+FRTYPE=<Param1>	0: Private friend 1: Open friend Default: 0

Instruction: For private friend type, data can only be sent to the MAC address of the friend set by AT+RIEND. If the MAC address is different from that of at + friend, data cannot be sent. Open friend type, you can specify all friends around to send data one-to-one.

For the use of friend relation, please refer to the use instruction of MESH for details.

### 32、 Set/query - iBeacon UUID

Instruction	Response	Parameter
AT+IBUUID<Param>	OK	Param: Hex UUID
AT+IBUUID	+IBUUID=<Param>	Default: FDA50693A4E24FB1AFCFC6EB076 47825

Example: 41 54 2B 49 42 55 55 49 44 FD A5 06 93 A4 E2 4F B1 AF CF C6 EB 07 64 78 25 0D 0A

AT+IBUUID FDA50693A4E24FB1AFCFC6EB07647825 end mark

### 33、 Set/query - iBeacon Major

Instruction	Response	Parameter
AT+MAJOR<Param>	OK	Param: (0000-FFFF)
AT+MAJOR	+ MAJOR=<Param>	Default: 000A

If Major value is 10008, AT instruction is: AT+MAJOR2718 2718 is 10008 hex data

### 34、 Set/query - iBeacon Minor

Instruction	Response	Parameter
-------------	----------	-----------

## JDY-25M **Super BLE** Bluetooth Module

AT+MINOR<Param>	OK	Param: (0000-FFFF)
AT+MINOR	+MINOR=<Param>	Default: 0007

If Minor value is 10180, AT instruction is: AT+MINOR27C4      27C4 is 10180 hex data

### 35、Set/query - iBeacon IBSING

Instruction	Response	Parameter
AT+IBSING<Param>	OK	Param: (00-FF)
AT+IBSING	+IBSING =<Param>	Default: 40

This parameter is applied to the check value of iBeacon signal at 1 meter.

### 36、Serial port status output enable set/query

Instruction	Response	Parameter
AT+ENLOG<Param>	+OK	Param: 1 or 0
AT+ENLOG	+ENLOG=<Param>	1: Open serial port status output 0: Close serial port status output Default: 1

### 37、Data instruction sent by multi-connected slave

Instruction	Response	Parameter
AT+DATA<Param1><Param2> >	+OK	Param1: Indicates the master ID number, values (1 to 4) Param2: Indicates the data sent
	+DATA=<Param>	

In the multi-connected status, when JDY-25M is connected by more than one master, data can be sent to the specified master through this instruction.

Example: Such as sending AABBCCDDEEFF data to master 1

**AT+DATA1AABBCCDDEEFF**

### 38、Set/query - Output IO level of current module

Instruction	Response	Parameter
AT+CUIO<PA>,<PB>,<PB>	+OK	PA: Output IO number (1 to 5)

## JDY-25M **Super BLE** Bluetooth Module

AT+CUIO	+CUIO=<P1>,<P2>,<P3>,<P4>,<P5> ,	PB: Indicates output level P1: Indicates OUTPUT1 level P2: Indicates OUTPUT2 level P3: Indicates OUTPUT3 level P4: Indicates OUTPUT4 level P5: Indicates OUTPUT5 level
---------	-------------------------------------	---

Note: This instruction only controls the IO level of the current module through the serial port.

### 39、Master setting/query - Remote slave output IO level

Instruction	Response	Parameter
AT+TGIO<PA>,<PB>,<P1>,<P2>,<P3>,<P4>,<P5>	+OK	PA: Output IO number (1 to 5) PB: Indicates output level P1: Indicates OUTPUT1 level P2: Indicates OUTPUT2 level P3: Indicates OUTPUT3 level P4: Indicates OUTPUT4 level P5: Indicates OUTPUT5 level
AT+TGIO	+TGIO=<P1>,<P2>,<P3>,<P4>,<P5> ,	PB: Indicates output level P1: Indicates OUTPUT1 level P2: Indicates OUTPUT2 level P3: Indicates OUTPUT3 level P4: Indicates OUTPUT4 level P5: Indicates OUTPUT5 level

Note: This instruction is the master controls the slave level after the master-slave connection.

### 40、Master setting/query - Remote slave wireless parameters

Instruction	Response	Parameter
AT+FUNC<Param>	+OK	Param: Please refer to page 18 for wireless setting instruction table: <b>APP configures current device instruction table</b>

Note: Only when the master is connected to the slave can the instruction be sent effectively.

### 41、Set/query - Subtype parameters

Instruction	Response	Parameter
AT+SUBTYPE<Param>	+OK	Param: 1 or 0 1: KEY and OUTPUT associated 0: KEY and OUTPUT not associated

## JDY-25M **Super BLE** Bluetooth Module

AT+SUBTYPE	+SUBTYPE=<Para m>	Default: 0
------------	----------------------	------------

Note: After the SUBTYPE is set to 1, the level of the remote device controlled by the INPUT key will change as the level of its OUTPUT pin.

For example, INPUT1 controls the remote device INPUT1 level to high level, and its own INPUT1 pin will also become high level.

### 42、Set/query - Learn switch enable

Instruction	Response	Parameter
AT+LEARN<Param>	+OK	Param: 1 or 0
AT+LEARN	+LEARN=<Para m>	1: Button and output pin learn mode on 0: Button and output pin learn mode off Default: 0

Note: When LEARN is set to 1, it means the parameters of INPUT pin set by AT+KEY are completely invalid. The parameters of key sending and receiving will be acquired by AT+LEAVAL or key learning.

For key learning configuration, please refer to the document *Switch panel instructions. PDF*.

### 43、Set/query - Learn parameter

Instruction	Response	Parameter
AT+LEAVAL <P1>,<P2>,<P3>	+OK	P1: OUTPUT pin number of current device
AT+LEAVAL	+LEAVAL= <P1>,<P2>,<P3>	P2: Code sender INPUT pin number P3: Code sender short address (0001-FF00) Default: 0,0,0000

When LEARN mode is on, AT+LEAVAL instruction configures parameters.

Example 1: Remote 0008 device KEY1 simultaneously controls the current device's OUTPUT1 and OUTPUT2 levels

Current device sends instruction: AT+LEAVAL1,1,0008 send AT+LEAVAL2,1,154A

Example 2: Remote 0008 device KEY2 controls the current device's OUTPUT5 level

Current device sends instruction: AT+LEAVAL5,2,0008

### 44、Set/query - Turn on one key binding to connect the strongest signal slave

Instruction	Response	Parameter
-------------	----------	-----------

## JDY-25M **Super BLE** Bluetooth Module

AT+DEVCLSS<Param>	+OK	Param: 00 or ff F1: indicates that one key binding function is turned on (In ROLE1 mode, support pressing PWRC pin to bind and
AT+DEVCLSS	+DEVCLSS=<Param>	connect to the strongest signal slave nearby)
>	m>	Default: 0

Example: In ROLE1 mode, press PWRC pin to automatically bind the strongest signal slave nearby and send AT+DEVCLSSF1

### 45、Set/query - Key label address addition

Instruction	Response	Parameter
AT+KLABEL<Param1>,<Param2>,<Param3>	+OK	Param1: label number (Value 0-9) Param2: action IO number (Value 1-5)
AT+KLABEL<Param1>>	+KLABEL=<Param1>,<Param2>,<Param3>	Param3: label MAC address (12 character string) Default: 0,0,000000000000

In ROLE8 key label detection mode, add bracelet or label,

For example, the MAC address of the bracelet is 112233445566. When the bracelet is close to JDY-25M, let OUT2 act. The instructions are as follows.

AT+KLABEL1,2,112233445566

We add another key label. The MAC address of the key label is 888888999999. When the key label is close to JDY-25M, make OUT5 act, the instruction is: AT+KLABEL2,5,888888999999

### 46、Set/query - Overtime action time of opening a key label

Instruction	Response	Parameter
AT+KLTIME<Param>,<Param>m>	+OK	Param1: label number (Value 0-9) Param2: overtime time (Value 0-9)
AT+KLTIME<Param>	+KLTIME=<Param>,<Param>	Param2 default: 3

In ROLE8 key label detection mode, bracelet and key labels have been added,

Example: Set the overtime time of the bracelet to 9 seconds. (After the bracelet is close to JDY-25M, OUT2 always outputs high level. When the bracelet leave the JDY-25M range, OUT2 reverts to low level in 9 seconds. If the bracelet enters the JDY-25M range again within the 9 seconds, OUT2 outputs high level again.)

Instruction: AT+KLTIME1, 9

## JDY-25M **Super BLE** Bluetooth Module

---

### 47、Set/query - Sensitivity of opening a key label

Instruction	Response	Parameter
AT+KLRSSI<Param>,<Param>  >	+OK	Param1: label number (Value 0-9) Param2: sensitivity (Value 00-99)
AT+KLRSSI<Param>	+KLRSSI=<Param>,<  Param>	Param2 default: 99

In ROLE8 key label detection mode, bracelet and key labels have been added,

Example: Set the receiving range of the bracelet to a relatively close distance. Only when the bracelet is in this range can the OUT pin of JDY-25M act.

Instruction: AT+KLRSSI30

The above parameter setting is 30. Of course, the value of KLRSSI can be set anyone from 00 to 99. Users can set it according to their own requirements.

### IX. APP terminal instruction

#### UUID list

Service UUID: FFE0	(Service UUID)
Service UUID: FFE1	(Used for transparent transmission)
Service UUID: FFE2	(Used for transparent transmission)
Service UUID: FFE3	(MESH data receiving and sending, MESH instruction receiving and sending, APP control IO, parameter configuration)

APP command instructions (Not mesh mode)

**1)APP transparent transmission** (Use characteristic UUID: FFE1)

0XFFE1 is APP transparent transmission characteristic UUID (**Applied to IOS, Android or Wechat applet communication**)

2) APP sends data or instruction to MESH (Use characteristic **FFE3**)

Data format **HEAD(2byte)** + **CMD(1byte)** + **MADDR(2byte)** + data(1-16byte)

Example 1: APP broadcasts data to all devices:31323334353637383930

Instruction 1: **F10100FFFF**31323334353637383930

Example 2: APP sends 1122334455 data to 0008 device serial port

Instruction 2: **F101000008**1122334455

Example 3: APP sets OUT1 pin of all modules to high level

Instruction 3: **F10110FFFF**AAB1E70101

Example 4: APP sets OUT1 pin of 0008 module to low level

Instruction 4: **F101100008**AAB1E70100

Example 5: APP reads all OUT pin levels of 0008 module

Instruction 5: **F101310008**F0B100

Example 6: APP reads all INPUT pin levels of module 0008

Instruction 6: **F101310008**F1B101

Example 7: APP reads all INPUT pin levels of 0008 module

Instruction 7: **F101310008**F1B101

Note: The above are just some examples of APP sending data to MESH, including setting NETID, setting MADDR, communicating with friend node, setting friend type, setting route or terminal node, etc.lease refer to **MESH user manual. PDF**. The MESH communication format of APP is the same as that of AT instruction of serial port, except the data head.



## JDY-25M **Super BLE** Bluetooth Module

3) **APP configures current device instruction table** ( Use characteristic UUID : 0XFFE3)

This instruction is only used for the current APP connected device parameter configuration.

<b>Instru ction</b>	<b>Data</b>	<b>Function description</b>
F202	NETID	APP sets the network NETID, with the length of 2 bytes
F303	MADDR	APP sets short address, MADDR length is 2 bytes
F404	MCLSS	APP sets network type, MCLSS length is 1 byte, 0 represents router, 1 represents terminal device
F505	ROLE	APP sets the working mode, and the length of ROLE is 1 byte, 0: Indicates slave transparent transmission 1: Indicates master transparent transmission 2: BLE broadcast probe mode 3: iBeacon mode 4: iBeacon probe mode 5: MESH network mode 6 : Multi-connected and multi machine mode ( Support simultaneous connection transparent transmission of 4 masters) 7 : Multi-connected master slave mode ( Support master to connect 4 slaves) 8: Key label detection mode
F606	x1x2x3x3x5	APP sets key parameters x1: Indicates key number, range (1 to 5) x2x3: Indicates the target address of key, range (0000-ffff) x4: Indicates the target output pin number, range (1 to 5) x5: Indicates whether the target receive data and the serial port output at the same time, range (0-1)
F707	SUBTYPE	SUBTYPE=1 in MESH mode indicates that OUT and target are synchronized SUBTYPE=0 in MESH mode indicates that OUT and target are not synchronized
F808	LEARN	LEARN=1 in MESH mode indicates open learning function 0 indicates close learning function
F909	x1x2x3x4	x1 indicates the OUTPUT pin number of the current device x2 indicates code sender INPUT pin number x3x4 indicates the short address of the code sender (0001-FF00)
FA01	DEVCLSS	DEVCLSS=F1 indicates open the function of one key bind and connect to the strongest signal slave DEVCLSS =0 indicates close
		x1: Label number ( Value 0x00-0x09)

## JDY-25M **Super BLE** Bluetooth Module

FA02	x1x2mac	x2: Action IO number (Value 0x01-0x05) Mac: Label MAC address (Value 0x000000000000-0xfffffffffff)
FA03	x1x2	x1: Label number (Value 0x00-0x09) x2: Overtime time (Value 0x00-0x09)
FA04	x1x2	x1: Label number (Value 0x00-0x09) x2: Sensitivity (Value 0x00-0x99)
B101	UUID	UUID of iBeacon, length 16 bytes
B202	MAJOR	MAJOR of iBeacon, length 2 bytes
B303	MINOR	MINOR of iBeacon, length 2 bytes
B404	SING	Signal verification value of iBeacon at 1m, length 1byte
A1E1	F101	APP sends this instruction to restart the module, fixed instruction (A1E1F101)
A2E2	NAME	NAME is broadcast name, the maximum length of NAME is 18 bytes
A3E3	PIN	PIN connection password, PIN length is 6 bytes
A4E4	TYPE	TYPE matching method, length is 1byte 0: No password for connection 1: Password connection and not binding 2: Password connection and binding
A5E5	BAUD	BAUD is baud rate, length is 1byte 2: 2400 3: 4800 4: 9600 5: 19200 6: 38400 7: 57600 8: 115200
A6E6	01	APP disconnect instruction, fixed instruction (A6E601)
A7E7	STARTEN	STARTEN Whether it is power on sleep, the length is 1 byte 1 : Power on wake-up, sleep can be controlled by sleep instruction 0: Power on sleep, connect wake-up, disconnect sleep
A8E8	ADVINT	ADVINT is broadcast interval, the length is 1 byte 1: 100mS 2: 200mS 3: 300mS 4: 500mS 5: 700mS 6: 100mS 7: 1500mS 8: 3000mS 9: 6000mS

## JDY-25M **Super BLE** Bluetooth Module

A9E9	POWER	POWER is transmitting power, the length is 1 byte 0: -20db 1: 0db 2: 2db 3: 3db 4: 4db
AAEA	DEFAULT	Restore factory configuration
C101	NULL	Read module software version number
C102	NULL	Read broadcast name value, length (1 to 18) bytes
C103	NULL	Read password value, length 6 bytes
C104	NULL	Read password type value, length 1 byte
C105	NULL	Read baud rate value, length 1 byte
C106	NULL	Read power on sleep value, length 1 byte
C107	ADVSTAT	
C108	NULL	APP reads transmitting power
C109	NULL	APP reads ROLE working mode
C201	NULL	Read the UUID of iBeacon, length 16 bytes
C202	NULL	Read the MAJOR of iBeacon, length 2 bytes
C203	NULL	Read the MINOR of iBeacon, length 2 bytes
C204	NULL	Read the SING of iBeacon, length 1 byte
C301	NULL	Read MESH network NETID, length 2 bytes
C302	NULL	Read MESH network MADDR, length 2 bytes
C303	NULL	Read MESH network type MCLSS, length 1 byte
C304	NULL	APP reads key 1 parameter
C305	NULL	APP reads key 2 parameter
C306	NULL	APP reads key 3 parameter
C307	NULL	APP reads key 4 parameter
C308	NULL	APP reads key 5 parameter
C309	NULL	Read SUBTYPE parameter
C30A	NULL	Read LEARN parameter
C30B	NULL	Read learner OUTPUT1 LEARN parameter
C30C	NULL	Read learner OUTPUT2 LEARN parameter
C30D	NULL	Read learner OUTPUT3 LEARN parameter
C30E	NULL	Read learner OUTPUT4 LEARN parameter
C30F	NULL	Read learner OUTPUT5 LEARN parameter
C310	NULL	Read DEVCLSS parameter
C311	x1	Read LABEL parameter

## JDY-25M **Super BLE** Bluetooth Module

		x1: Label number (Value 0x00-0x09)
C312	x1	Read KLTIME parameter x1: Label number (Value 0x00-0x09)
C313	x1	Read KLRSSI parameter x1: Label number (Value 0x00-0x09)

### X. Wiring diagram of JDY-25M module application

#### 10.1 Wiring diagram of data transparent transmission between JDY-25M and mobile phone (IOS, Android) APP and applet

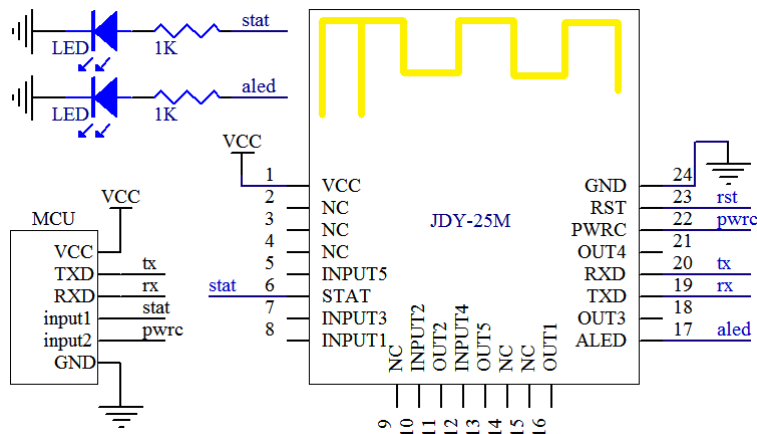

Note: Only 4 wires (VCC, GND, RXD, TXD) need to be connected for general transparent transmission. MCU can judge the working state (connection, disconnection) of Bluetooth through serial port state. If Bluetooth output status (connection, disconnection) is not required, it can be determined by Bluetooth status pin or by pulling down PWRC pin (send AT+STAT).

#### 10.2 JDY-25M non MESH master-slave transparent transmission wiring diagram

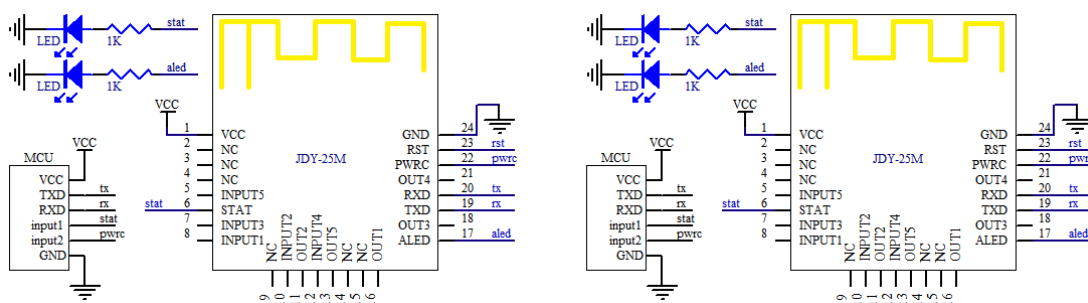

The master-slave communication speed rate supports continuous data transmission at all baud rates (under 115200 baud rate, the data can be transmitted without delay and can be continuously transmitted and received)

Master instruction: **AT+ROLE1**

**AT+RESET**

Search slave instruction: **AT+INQ**

After the slave is searched, use **AT+CONA** to connect the MAC address of the searched slave.

## JDY-25M **Super BLE** Bluetooth Module

### 10.3 Wiring diagram of output pin level of APP control module in JDY-25M non network mode

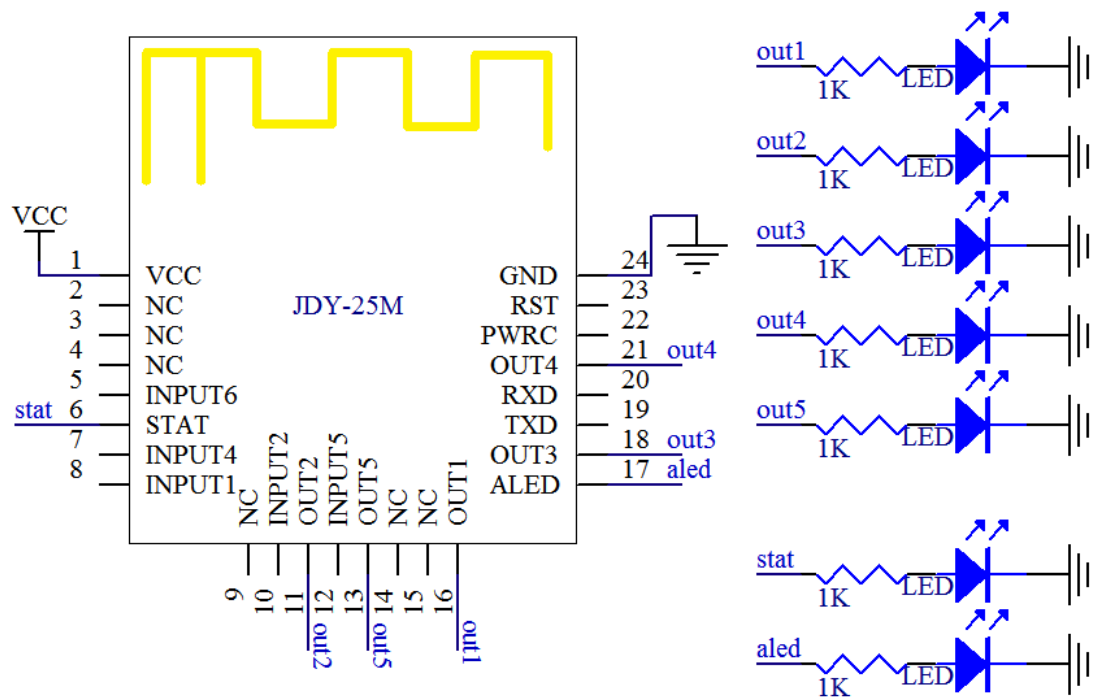

In the AT+ROLE0, AT+ROLE3, AT+ROLE6, AT+ROLE7 modes, it support APP to directly control OUTPUT pin level

APP selects the FFE2 characteristic and sends instructions as follows

Function	APP instruction (Characteristic FFE2)	Description
Control OUTPUT1 pin high level	E7F101	
Control OUTPUT1 pin low level	E7F100	
Control OUTPUT2 pin high level	E7F201	
Control OUTPUT2 pin low level	E7F200	
Control OUTPUT3 pin high level	E7F301	
Control OUTPUT3 pin low level	E7F300	
Control OUTPUT4 pin high level	E7F401	
Control OUTPUT4 pin low level	E7F400	
Control OUTPUT5 pin high level	E7F501	
Control OUTPUT5 pin low level	E7F500	
APP reads 5 output pin level	E7FAFF	Return E7FAFF <b>00000000</b> 5 colors mean 5 output IO levels

In the non network module, APP can not only directly control the OUTPUT pin level, but also support transparent transmission.

### 10.4 JDY-25M network IO control wiring diagram

# JDY-25M Super BLE Bluetooth Module

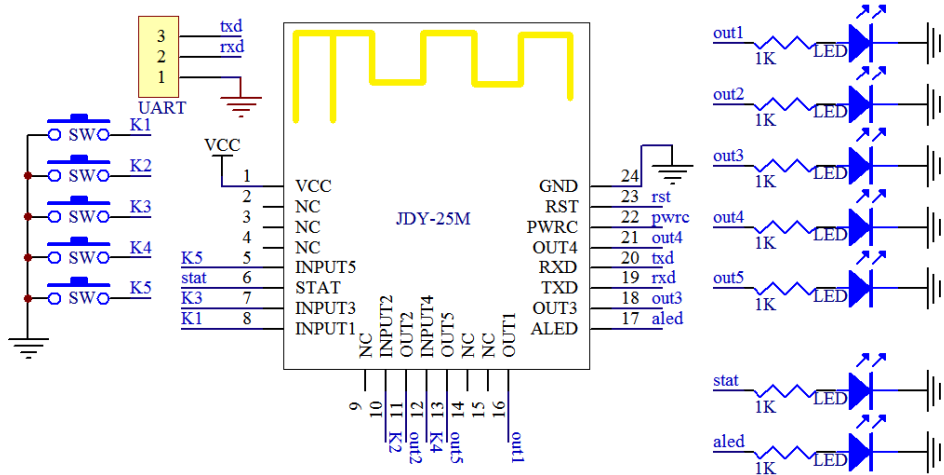

This circuit is mainly used for routing nodes. The key supports to control the IO or serial port output key information of all nodes (routing, terminal) in the network.

Network IO control instructions are as follows:

AT+ROLE5

AT+RESET

After configuration, IO control can be carried out. By default, the short address of INPUT1 to INPUT5 is FFFF. Press the INPUT pin SW key by default to output IO to control the corresponding OUTPUT of all devices in the network. If you do not need to control the OUTPUT pin of all devices, you can configure it with the following instructions.

Example 1: The INPUT5 key with the local machine address of 0005 needs to control the OUTPUT5 pin level of 0008 device

0005 local machine instruction as follows: AT+KEY5,0008,5,0

Example 2: The INPUT1 key with the local machine address of 0005 needs to control the OUTPUT3 pin level of 0008 device

0005 local machine instruction as follows: AT+KEY1,0008,3,0

Note that this mode is non learning mode key switch and output IO control. AT+LEARN0 and AT+SUBTYPE0 are both set to 0, and the module factory default is 0.

## 10.5 Serial port communication wiring diagram between MCU and MCU in JDY-25M

# JDY-25M **Super BLE** Bluetooth Module

## network

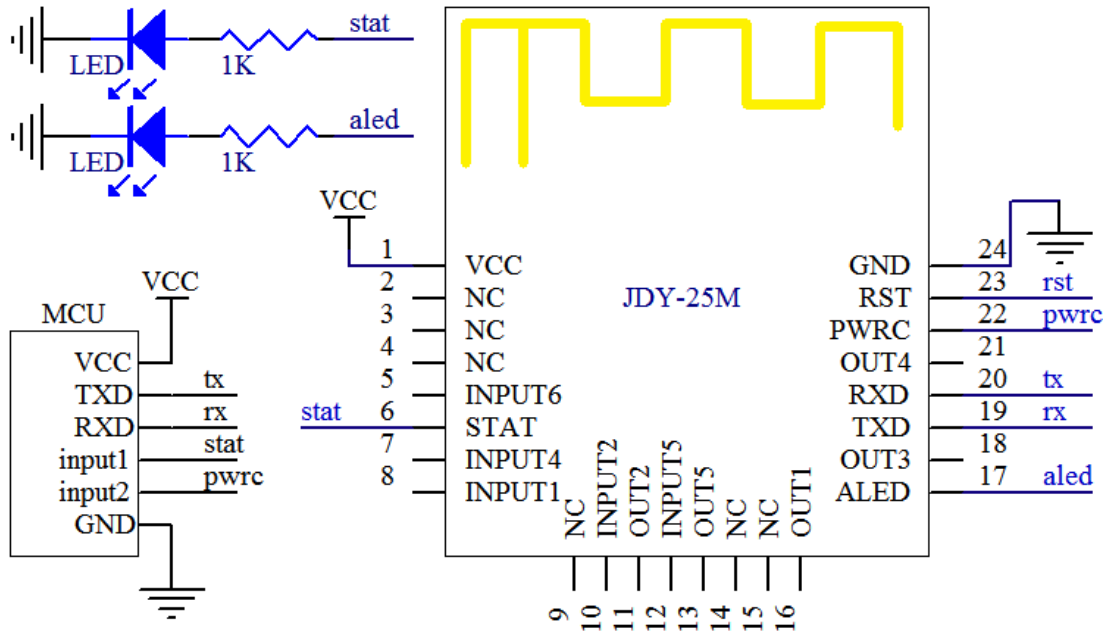

In this wiring, the user MCU can realize wireless serial port communication between multiple MCU, and can also control the output IO level of all nodes, and read the input IO level status (input1 to input5).

Example 1: Serial port of local 0005 device sends 112233445566 hex data to the serial port of target 0008 device

Instruction: 41 54 2b 4d 45 53 48 00 00 08 31 32 33 0d 0a

Example 2: Serial port of local 0005 device serial port sends 112233445566 hex data to all device serial ports in the network

Instruction: 41 54 2b 4d 45 53 48 00 ff ff 31 32 33 0d 0a

Example 3: Serial port of local 0005 device reads 5 OUTPUT pin levels of target 0008 device

Instruction: 41 54 2b 4d 45 53 48 31 00 08 f0 b1 00 0d 0a

Return: F0 00 07 00 08 00 00 00 00 00

Example 4: Serial port of local 0005 device reads 5 INPUT pin levels of target 0008 device

Instruction: 41 54 2b 4d 45 53 48 00 00 08 f1 b1 01 0d 0a

Return: F0 01 07 00 08 01 01 01 01 01

Example 5: Serial port of local 0005 device controls the OUTPUT1 pin of the target 0008 device as high level

Instruction: 41 54 2b 4d 45 53 48 10 00 08 aa b1 e7 01 01 0d 0a

Example 6: Serial port of local 0005 device controls the OUTPUT pin of the target 0008 device as high level

Instruction: 41 54 2b 4d 45 53 48 10 00 08 ab b1 e7 ff 1f 0d 0a

## 10.6 JDY-25M network remote control node wiring diagram

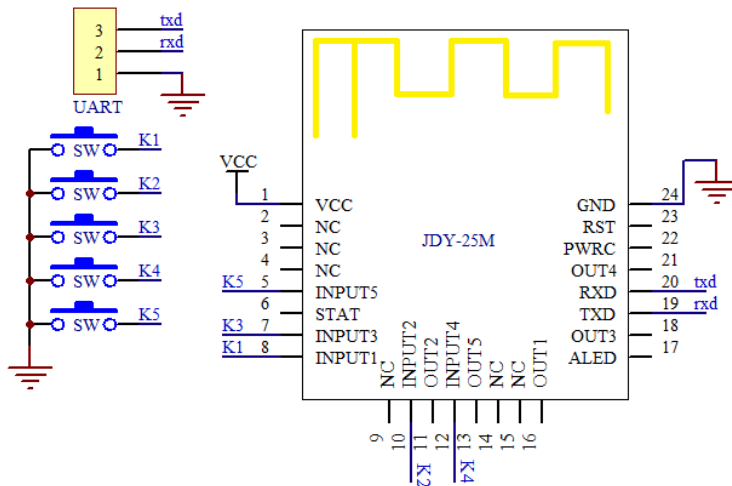

This node is generally used for panel switch and remote controller. The terminal node is generally powered on sleep. Press the key to send data, and release the key to continue deep sleep immediately.

### Configure remote control node instruction

1. Configure to MESH mode: **AT+ROLE5**
2. Configured as a low-power consumption node: **AT+MCLSS1**
3. Restart to take effect: **AT+RESET**

## 10.7 Application wiring diagram of network switch panel

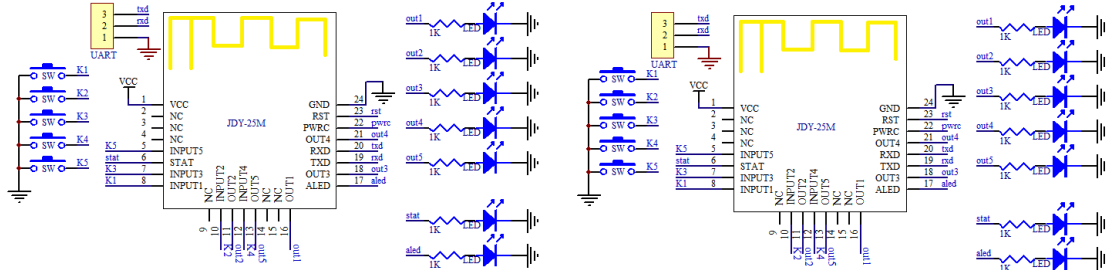

Before the installation of the switch panel, it is necessary to configure the module network, and open the parameters such as **AT+SUBTYPE1** and **AT+LEARN1** to factory setting, and learn during installation. The above circuit diagram is the application circuit diagram of the switch panel. The above two devices support hundreds or thousands of circuit devices in the practical application.

Example: We control the level of LED2 and LED5 of B switch panel by SW1 of A switch panel. At this time, LED2 and LED5 of B switch panel need to learn the key of SW1.

Step 1: Make A switch panel enter the code sender mode, click the PWRC pin on A switch panel, and the LED light on a switch panel flashes slowly, indicating that the code sender mode has entered.

Step 2: Make B switch panel enter the learner mode, double-click the PWRC pin of the B switch panel, the ALED of the B switch panel is off, and the STAT pin flashes slowly, indicating that the learner mode has been entered. First, learn LED2 (press SW2 of B switch panel), at this time, LED2 light flashes (once a second), then press SW1 of A switch panel code sender, LED2 of B



## JDY-25M **Super BLE** Bluetooth Module

switch panel learns the value sent by SW1 of A switch panel, and LED2 of B switch panel will be on, which indicates that LED2 has learned successfully. Second, press SW5 of B switch panel, at this time, LED5 of B switch panel flashes, which indicates that LED5 learning begins. Then press SW1 of switch panel A, LED5 of switch panel will be on, which indicates that learning has been successful.

Step 3: A switch panel quit code sender mode, click PWRC pin, and LED of ALED pin flashes (once in 1 second), indicating that the code sender mode has quit and normal working mode has been entered.

Step 4: B switch panel quit learner mode, double-click PWRC pin, and LED of ALED pin flashes (once in 1 second), indicating that the learner mode has quit and normal working mode has been entered.

Step 5: At this time, SW1 of A switch panel can control the level of LED2 and LED5 of B switch panel.

**Clear learning code, press PWRC pin for more than 6 seconds, and all learning codes will be cleared automatically.**

The above is the configuration of the switch panel by learning mode. If using APP or serial port to configure, it will be very simple to use.

If the user configures the above functions through the serial port, only several instructions are needed.

A switch panel address is 0008, B switch panel address is 0009

- 1、 AT+LEARN1
- 2、 AT+SUBTYPE1
- 3、 AT+LEAVAL2,1,0008
- 4、 AT+LEAVAL5,1,0008

### **10.8 Application wiring diagram of one key binding and connect to the strongest signal slave**

# JDY-25M **Super BLE** Bluetooth Module

nearby

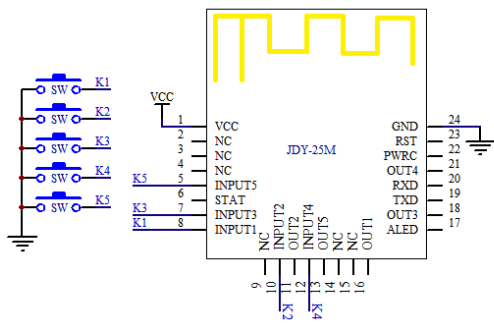

**Bluetooth remote control transmitter**

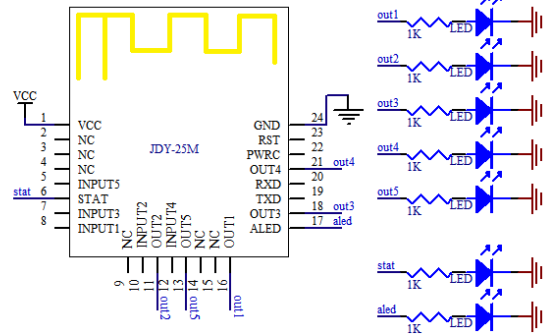

**Bluetooth remote control receiver**

## Bluetooth remote control application instruction mode 1 (LED light level flip)

**Bluetooth transmitter configuration instruction** **Bluetooth receiver configuration instruction**

**AT+ROLE1**

**AT+ROLE0**

**AT+DEVCLSSF1**

**AT+RESET**

**AT+RESET**

After the configuration of instructions through the above **transmitter** and **receiver**, the **transmitter** presses the SW5 button briefly, and the **transmitter** automatically searches for and bind the strongest signal **receiver** nearby. After the automatic connection, the LED of STAT pin is on, indicating that the binding is successful. After the binding is successful, the transmitter presses the SW1, SW2, SW3, SW4, PWRRC pins briefly to control the **receiver** of LED1, LED2, LED3, LED4, LED5. The control mode is **level flip mode**.

## Bluetooth remote control application instruction mode 2 (pulse level)

**Bluetooth transmitter configuration instruction** **Bluetooth receiver configuration instruction**

**AT+ROLE1**

**AT+ROLE0**

**AT+DEVCLSSF2**

**AT+RESET**

**AT+RESET**

After the configuration of instructions through the above **transmitter** and **receiver**, the **transmitter** presses the SW5 button briefly, and the **transmitter** automatically searches for and bind the strongest signal **receiver** nearby. After the automatic connection, the LED of STAT pin is on, indicating that the binding is successful. After the binding is successful, the transmitter presses the SW1, SW2, SW3, SW4, PWRRC pins briefly to control the **receiver** of LED1, LED2, LED3, LED4, LED5. The control mode is **pulse level**.

In the mode of **AT+DEVCLSSF1** or **AT+DEVCLSSF2**, the **transmitter** supports long press of SW5 button for 6 seconds to enter into deep sleep. After sleep, the current will be several uA, and after sleep, it can be waken up by short press of PWRRC pin.

## 10.9 Key label detection application wiring diagram

## JDY-25M **Super BLE** Bluetooth Module

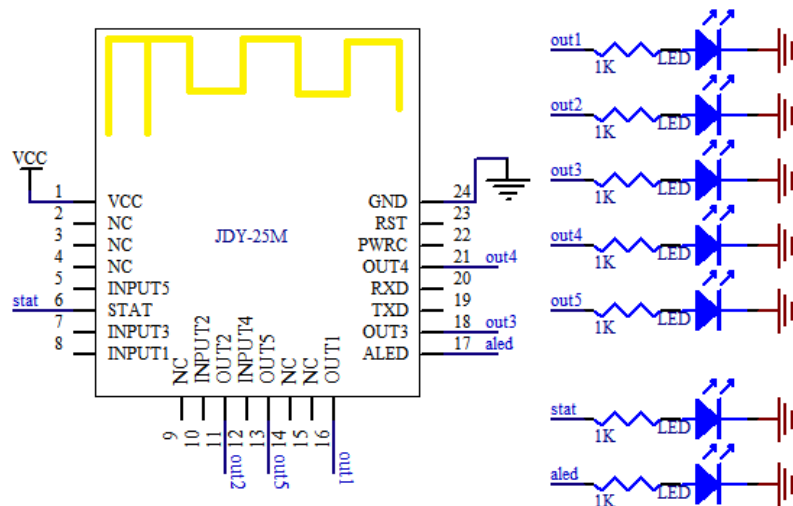

Key label detection is generally used in gate switch, check in, anti-loss and other fields.

When JDY-25M detects the key label or bracelet approaching, OUT outputs pin action.

Example: the MAC of the bracelet is 112233445566. When the bracelet is close, the OUT2 pin action instruction is as follows.

**AT+ROLES**

**AT+KLABEL1,2,112233445566**

**AT+RESET**

**JDY-25M supports binding 10 labels and 5 action OUT pins. The received label address will be output from the serial port. If you need to expand the number of labels, you can set the label address to the same, so that JDY-25M will have no upper limit on the number of labels, and users can also get the label address through MCU added by the serial port and to process MCU.**

## FCC Statement

This device complies with part 15 of the FCC Rules. Operation is subject to the following two conditions: (1) This device may not cause harmful interference, and (2) this device must accept any interference received, including interference that may cause undesired operation.

Any Changes or modifications not expressly approved by the party responsible for compliance could void the user's authority to operate the equipment.

**Note:** This equipment has been tested and found to comply with the limits for a Class B digital device, pursuant to part 15 of the FCC Rules. These limits are designed to provide reasonable protection against harmful interference in a residential installation. This equipment generates uses and can radiate radio frequency energy and, if not installed and used in accordance with the instructions, may cause harmful interference to radio communications. However, there is no guarantee that interference will not occur in a particular installation. If this equipment does

cause harmful interference to radio or television reception, which can be determined by turning the equipment off and on, the user is encouraged to try to correct the interference by one or more of the following measures:

- Reorient or relocate the receiving antenna.
- Increase the separation between the equipment and receiver.
- Connect the equipment into an outlet on a circuit different from that to which the receiver is connected.
- Consult the dealer or an experienced radio/TV technician for help.

The Video Light APP Module is designed to comply with the FCC statement. FCC ID is WUI-PYBLE50. The host system using Video Light APP Module, should have label indicated it contain modular's FCC ID:WUI-PYBLE50 . This radio module must not installed to colocate and operating simultaneously with other radios in host system additional testing and equipment authorization may be required to operating simultaneously with other radio.

The Video Light APP Module Module and its antenna must not be co-located or operating in conjunction with any other transmitter or antenna within a host device.

The modular must be installed in the host that assign by Company name: Winplus Co., Ltd. Product/PMN: Video Light APP Module Model no./HVIN: JDY-25M if other host types used would need further evaluation and possible C2PC if they are not significantly similar to the one tested

Notice to OEM integrator

The end user manual shall include all required regulatory information/warning as show in this manual. The OEM integrator is responsible for testing their end-product for any additional compliance requirements required with this module installed. If the final product contains circuits of other FCC PART 15 Subparts, the final host product still requires Part 15 Subpart B compliance testing with the modular transmitter installed. The intended use is generally not for the general public. It is generally for industry/commercial use. The connector is within the transmitter enclosure and can only be accessed by disassembly of the transmitter that is not normally required, the user has no access to the connector. Installation must be controlled. Installation requires special training.

This device complies with Part 15, Part 15.247 of the FCC Rules.

### **RF warning for portable device:**

The device has been evaluated to meet general RF exposure requirement. The device can be used in portable exposure condition without restriction.