

MODULE OF APP LPBUC

BT57799

Product Specification

1. Introduction

1.1 General Description

BT57799 wireless module is designed base on MT7601 . It is a wifi module which can support far than 100M communication.It operates at 2.412~2.462GHz, 2.422~2.452GHz and supports IEEE802.11b/g/n 1T1R , wireless data rate can reach up to 150Mbps.

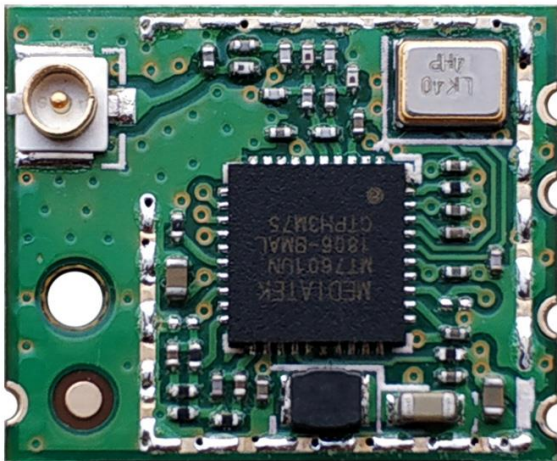

Figure 1 Top View

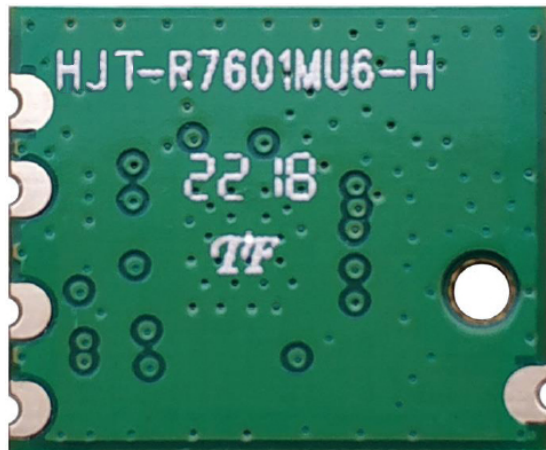

Figure 2 Bottom View

Note: The above pictures are for reference only

1.2 Features

- Operating Frequencies : 2.412~2.462GHz, 2.422~2.452GHz
- Host Interface is USB, complies with USB2.0
- IEEE Standards : IEEE 802.11b/g/n
- Wireless data rate can reach up to 150Mbps

- Connect to the external antenna through the IPEX connector
- Power Supply:3.3V±0.2V

1.3 Applications

- Imaging platforms (printers, digital still cameras, digital picture frames)
- Gaming platforms
- Consumer electronic devices (DTV,DVD players, Blu-ray players.etc.)
- Tablet, notebook, E-book
- Other devices which need to be supported by wireless network

2. Functional Block Diagram

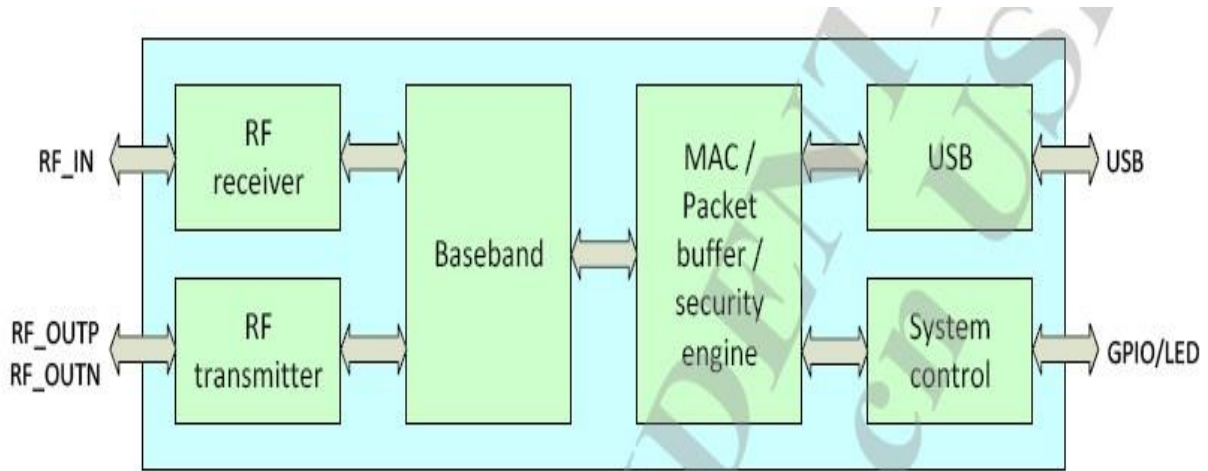

Figure 1 MT7601 block diagram

Figure 3 MT7601UN block diagram

3. Product Technical Specifications

3.1 General Specifications

Item	Description
Product Name	BT57799
Main Chip	MT7601
Host Interface	USB2.0
IEEE Standards	IEEE 802.11b/g/n
Operating Frequencies	2.412GHz~2.462GHz, 2.422GHz~2.452GHz
Modulation	802.11b: CCK, DQPSK, DBPSK 802.11g: 64-QAM,16-QAM, QPSK, BPSK 802.11n: 64-QAM,16-QAM, QPSK, BPSK

Working Mode	Infrastructure, Ad-Hoc
Wireless Data Rate	802.11b: 1, 2, 5.5, 11Mbps 802.11g: 6, 9, 12, 18, 24, 36, 48, 54Mbps 802.11n: MCS0~7, HT20 reach up to 72.2Mbps, HT40 reach up to 150Mbps
Rx Sensitivity	-94dBm (Min)
Antenna Type	Connect to the external antenna through the IpeX connector
Dimension(L*W*H)	15.7x 13x 2.1mm (LxWxH), Tolerance: ± 0.15 mm
Power Supply	3.3V ± 0.2 V
Power Consumption	Standby :100mA@3.3V (Max) TX mode :265mA@3.3V (Max)
Clock Source	40MHz
Working Temperature	-10° C to +50° C
Storage Temperature	-40° C to +70° C

ESD CAUTION: Although this module is designed to be as robust as possible, Electrostatic Discharge (ESD) can damage this module. It must be protected from ESD at all times and handled under the protection of ESD.

3.2 DC Characteristics

Absolute Maximum Ratings

Symbol	Parameters	Maximum rating	Unit
VDD33	3.3V Supply Voltage	3.5	V
VESD	ESD protection (HBM)	2000	V

Recommended Operating range

At room temperature 25 °C				
Symbol	Min.	Typ.	Max.	Unit
VDD33	3.1	3.3	3.5	V

3.3 DC Power Consumption

Vcc=3.3V, Ta = 25 °C, unit: mA				
Supply current	Typ.		Max	
Standby (RF disabled)	95		100	
802.11b	1Mbps		11Mbps	
Supply current	Typ.	Max.	Typ.	Max.

TX mode	255	265	225	238
RX mode	90	95	92	96
802.11g	6Mbps		54Mbps	
Supply current	Typ.	Max.	Typ.	Max.
TX mode	256	264	138	146
RX mode	90	94	95	98
802.11n HT20	7.2Mbps		72.2Mbps	
Supply current	Typ.	Max.	Typ.	Max.
TX mode	255	263	152	155
RX mode	90	94	98	99
802.11n HT40	15Mbps		150Mbps	
Supply current	Typ.	Max.	Typ.	Max.
TX mode	252	262	138	143
RX mode	90	95	98	99

3.4 RF Specifications

TX Constellation Error(EVM)	802.11b: $\leq -20\text{dB}@11\text{Mbps}$ 802.11g/11n-HT20: $\leq -28\text{dB}@54\text{Mbps}$ 802.11n-HT40: $\leq -28\text{dB}@150\text{Mbps}$
Receiver Minimum Input Sensitivity@PER	1Mbps: $\leq -94\text{dBm}@PER<8\%$; 11Mbps: $\leq -88\text{dBm}@PER<8\%$; 6Mbps: $\leq -90\text{dBm}@PER<10\%$; 54Mbps: $\leq -74\text{dBm}@PER<10\%$; 135Mbps: $\leq -70\text{dBm}@PER<10\%$;

4. Pin Assignments

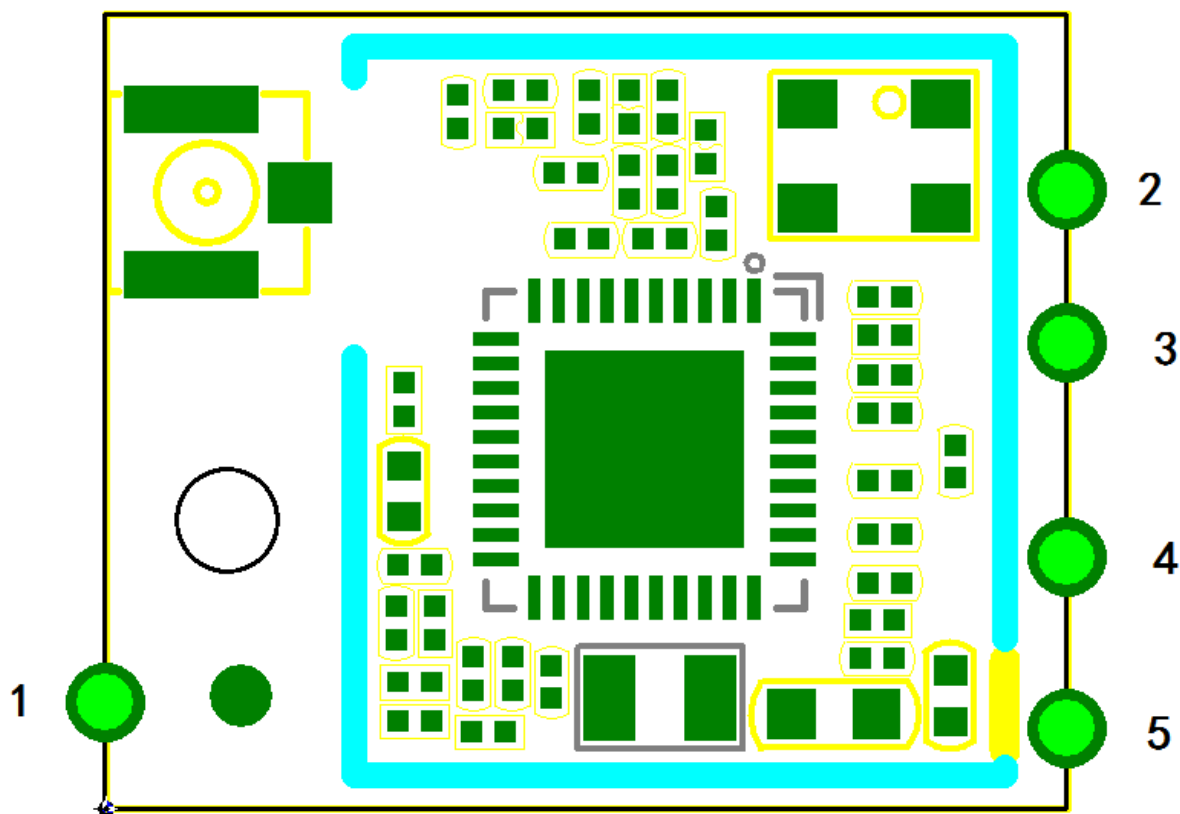

Figure 4 Pin Assignments (Top view)

Pin No:	Pin Name	Type	Description
1	GND	P	Ground
2	GND	P	Ground
3	UDP	I/O	USB Transmitter/Receiver Differential Pair
4	UDM	I/O	USB Transmitter/Receiver Differential Pair
5	VDD33	P	3.3V Power Supply

5. Application Information

5.1 Supported Platform

Operating System	CPU Framework	Driver
XP/WIN7/WIN8/8.1/WIN10	X86 Platform	Enable
Linux (kernel 2.6.24~4.2)	ARM ,MIPSII	Enable

5.2 Typical Application Circuit

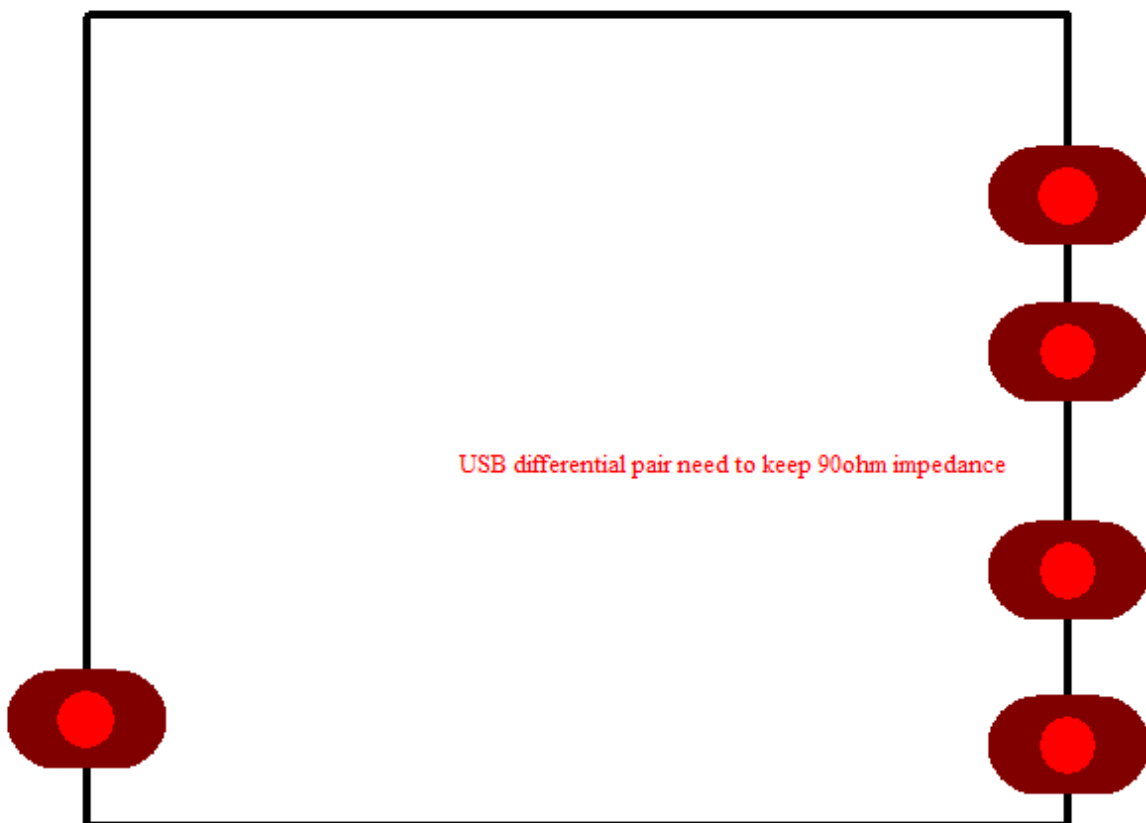

Figure 5 Recommended Layout Pattern

NOTE: USB differential pair need to keep 90ohm impedance.

6. Mechanical Specifications

Module dimension: Typical (L*W * H): 15.7mm*13.0mm*2.1mm Tolerance : +/-0.15mm

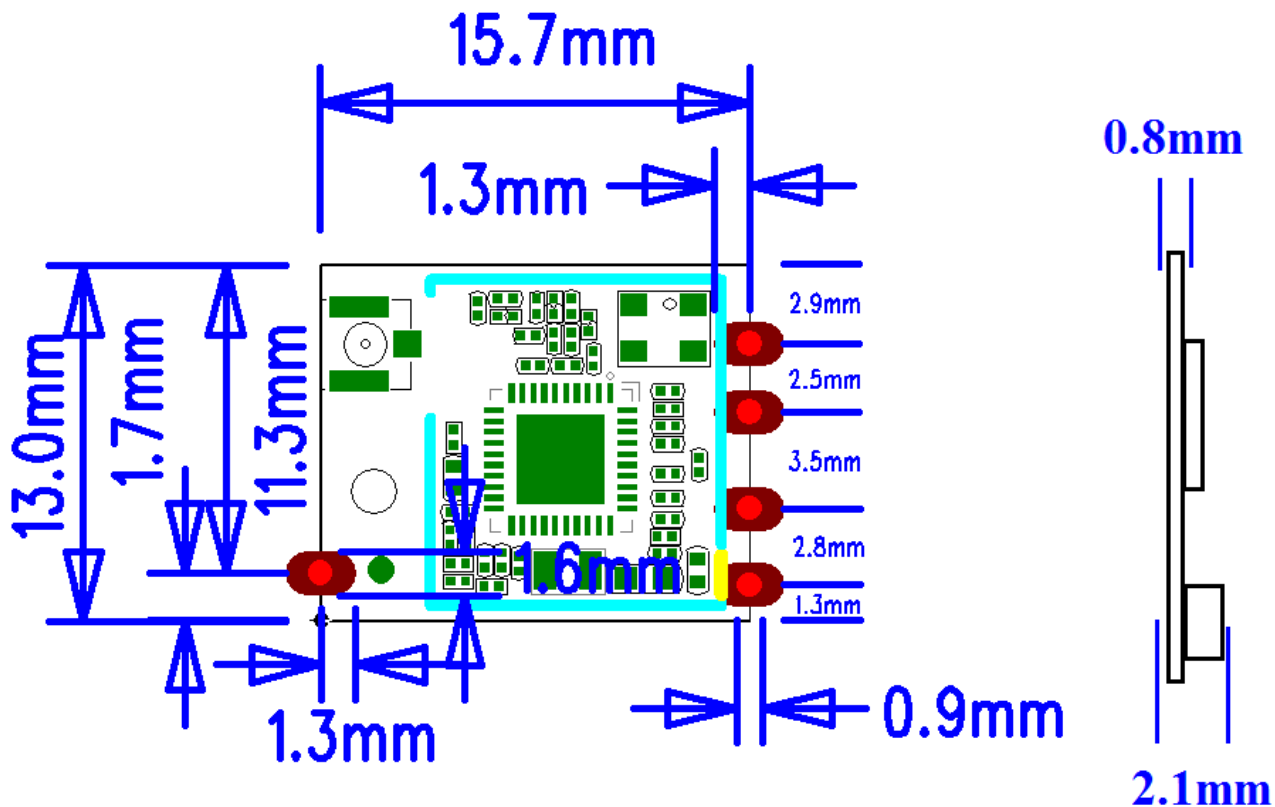

Figure 6 Module dimension

7. Others

7.1 Package Information



Figure 7 Package Information

7.2 Storage Temperature and Humidity

1. Storage Condition: Moisture barrier bag must be stored under 30°C, humidity under 85% RH.

The calculated shelf life for the dry packed product shall be a 12 months from the bag seal date.
Humidity indicator cards must be blue, <30%.

- Products require baking before mounting if humidity indicator cards reads > 30% temp < 30°C, humidity < 70% RH, over 96 hours.
Baking condition: 125°C, 12 hours.
Baking times: 1 time.

7.3 Recommended Reflow Profile

Reflow soldering shall be done according to the solder reflow profile, Typical Solder Reflow Profile is illustrated in Figures 15. The peak temperature is 245°C.

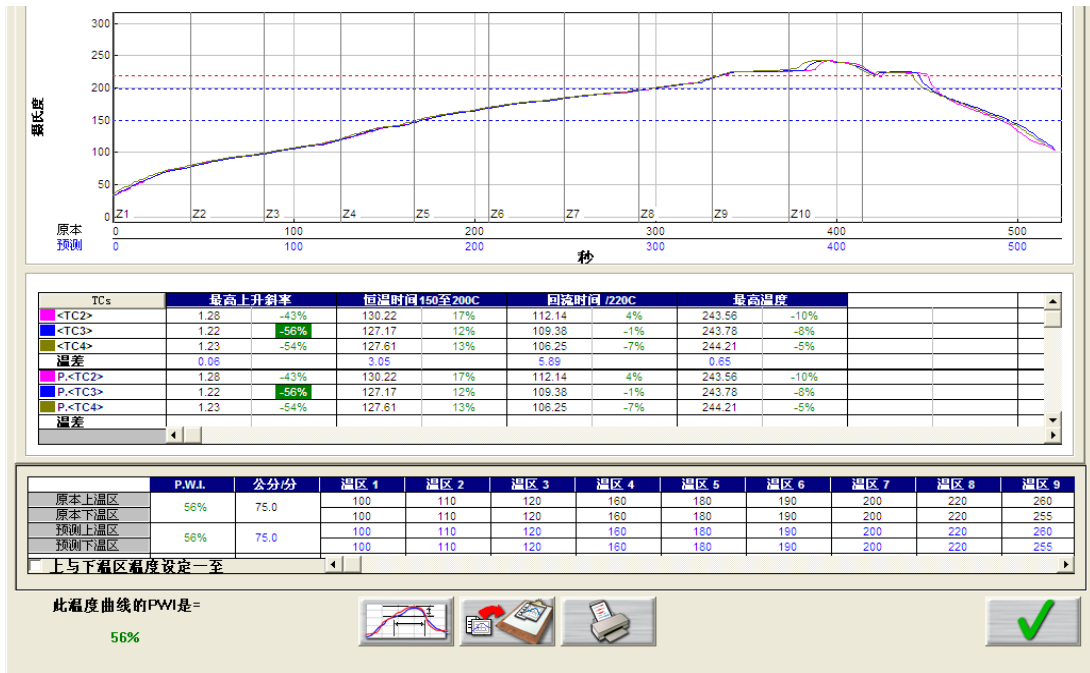

Figure 8 Typical Solder Reflow Profile

FCC Warning:

This device complies with part 15 of the FCC Rules. Operation is subject to the following two conditions: (1) This device may not cause harmful interference, and (2) this device must accept any interference received, including interference that may cause undesired operation.

Note: This equipment has been tested and found to comply with the limits for a Class B digital device, pursuant to part 15 of the FCC Rules. These limits are designed to provide reasonable protection against harmful interference in a residential installation. This equipment generates, uses and can radiate radio frequency energy and, if not installed and used in accordance with the instructions, may cause harmful interference to radio communications. However, there is no guarantee that interference will not occur in a particular installation. If this equipment does cause harmful interference to radio or television reception, which can be determined by turning the equipment off and on, the user is encouraged to try to correct the interference by one or more of the following measures:

- Reorient or relocate the receiving antenna.
- Increase the separation between the equipment and receiver.
- Connect the equipment into an outlet on a circuit different from that to which the receiver is connected.
- Consult the dealer or an experienced radio/TV technician for help.

Note: The Grantee is not responsible for any changes or modifications not expressly approved by the party responsible for compliance. Such modifications could void the user's authority to operate the equipment.

The OEM integrator is still responsible for testing their end-product for any additional compliance requirements required with this module installed.

IMPORTANT NOTE: In the event that these conditions cannot be met (for example co-location with another transmitter), then the FCC authorization is no longer considered valid and the FCC ID can not be used on the final product. In these circumstances, the OEM integrator will be responsible for re-evaluating the end product (including the transmitter) and obtaining a separate FCC authorization.

The OEM integrator has to be aware not to provide information to the end user regarding how to install or remove this RF module in the user's manual of the end product which integrates this module.

The BT57799 module is designed to comply with the FCC statement. FCC ID is WUI-BT57799. The host system using BT57799, should have label indicated it contain modular's FCC ID: WUI-BT57799.

RF warning statement:

The device has been evaluated to meet general RF exposure requirement.

To maintain compliance with FCC's RF exposure guidelines, the distance must be at least 20 cm between the radiator and your body, and fully supported by the operating and installation configurations of transmitter and its antenna(s).

IC Warning:

If the IC identification number is not visible when the module is installed inside another device, then the outside of the device into which the module is installed must also display a label referring to the enclosed module. This exterior label can use wording such as the following:

“Contains Transmitter Module IC: 7297A-BT57799

When the module is installed inside another device, the user manual of this device must contain below warning statements:

This device complies with Industry Canada licence-exempt RSS standard(s). Operation is subject to the following two conditions: (1) this device may not cause interference, and (2) this device must accept any interference, including interference that may cause undesired operation of the device.

Le présent appareil est conforme aux CNR d'Industrie Canada applicables aux appareils radio exempts de licence. L'exploitation est autorisée aux deux conditions suivantes : (1) l'appareil ne doit pas produire de brouillage, et (2) l'utilisateur de l'appareil doit accepter tout brouillage radioélectrique subi, même si le brouillage est susceptible d'en compromettre le fonctionnement.

RF warning statement:

The device has been evaluated to meet general RF exposure requirement. To maintain compliance with RSS-102 — Radio Frequency (RF) Exposure guidelines, this equipment should be installed and operated with a minimum distance of 20cm between the radiator and your body.

le dispositif de a été évalué à répondre général rf exposition exigence.pour maintenir la conformitéavec les directives d'exposition du RSS-102-Radio Fréquence (RF). ce matériel doit être installé etexploité à une distance minimale de 20 cm entre le radiateur et votre corps.