



# FCC Test Report

According to

**47 CFR Part 15 Subpart C**

**Equipment : Bluetooth Speaker**  
**Trade Name : MediaTrend**  
**Model Name : BTS-100i**  
**FCC ID : WUFMTREND**  
**Filing Type : Certification**  
**Applicant : MediaTrend Technology Inc.**  
7F, -4, No. 736, Jhongjheng Road,  
Jhonghe City, Taipei County 235, Taiwan

- Without written approval of SPORTON International Inc., the test report shall not be reproduced except in full.
- **Certificate or Test Report must not be used by the applicant to claim the product in this test report endorsement by NVLAP or any agency of U.S. government.**
- The data shown in this test report were carried out on Jul. 24, 2008 at **Sporton International Inc. LAB.**
- Report No.: FR843009, Report Version: Rev. 02.

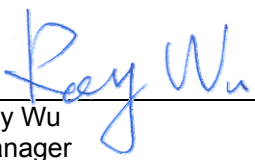
  
\_\_\_\_\_  
Roy Wu  
Manager

***SPORTON International Inc.***

***No. 52, Hwa Ya 1<sup>st</sup> Rd., Hwa Ya Technology Park, Kwei-Shan Hsiang, Tao Yuan Hsien, Taiwan, R.O.C.***

***SPORTON International Inc.***

TEL : 886-3-327-3456

FAX : 886-3-328-4978

Report Version: Rev. 02

## Table of Contents

History of This Test Report .....	ii
<b>1. General Description of Equipment under Test.....</b>	<b>1</b>
1.1. Applicant.....	1
1.2. Manufacturer .....	1
1.3. Basic Description of Accessories.....	1
1.4. Feature of Equipment under Test.....	1
<b>2. Test Configuration of Equipment under Test .....</b>	<b>2</b>
2.1. Test Manner .....	2
2.2. Test Mode .....	2
2.3. Ancillary Equipment List .....	2
2.4. Connection Diagram of Test System .....	3
<b>3. RF Utility .....</b>	<b>4</b>
<b>4. General Information of Test .....</b>	<b>5</b>
4.1. Test Voltage .....	5
4.2. Standard for Methods of Measurement .....	5
4.3. Test Compliance.....	5
4.4. Frequency Range.....	5
4.5. Test Distance.....	5
<b>5. Report of Measurements and Examinations .....</b>	<b>6</b>
5.1 List of Measurements and Examinations.....	6
5.2 Bandwidth of Frequency Band Edges .....	7
5.3 Hopping Channel Separation .....	10
5.4 Number of Hopping Frequency.....	14
5.5 Hopping Channel Bandwidth .....	16
5.6 Dwell Time of Each Frequency within a 30 Seconds Period .....	20
5.7 Peak Output Power Measurement.....	27
5.8 Conducted Emission.....	31
5.9 Radiated Emission Measurement.....	34
5.10 Antenna Requirements.....	48
<b>6 List of Measuring Equipments.....</b>	<b>49</b>
<b>7 Uncertainty Evaluation .....</b>	<b>50</b>
<b>Appendix A. Photographs of EUT</b>	
<b>Appendix B. Setup Photographs</b>	

## History of This Test Report

Report Issue Date: Nov. 19, 2008

Report No.	Description

# 1. General Description of Equipment under Test

## 1.1. Applicant

MediaTrend Technology Inc.

7F, -4, No. 736, Jhongjheng Road, Jhonghe City, Taipei County 235, Taiwan

## 1.2. Manufacturer

MediaTrend Technology Inc.

7F, -4, No. 736, Jhongjheng Road, Jhonghe Citym Taipei County 235, Taiwan

## 1.3. Basic Description of Accessories

AC Adapter	Brand Name	GEORA
	Model Name	GTAW0501000Z
	Power Rating	I/P: 100-240Vac, 50-60Hz, 0.2A; O/P: 5.0Vdc, 1.0A
USB Cable	Signal Line Type	1.4 meter shielded cable with ferrite core

Remark: Above EUT's information was declared by manufacturer. Please refer to the specifications of manufacturer or User's Manual for more detailed features description.

## 1.4. Feature of Equipment under Test

Product Feature & Specification			
DUT Type :	Bluetooth Speaker		
Trade Name :	MediaTrend		
Model Name :	BTS-100i		
FCC ID :	WUFMTREND		
Tx Frequency :	2400 MHz ~ 2483.5 MHz		
Rx Frequency :	2400 MHz ~ 2483.5 MHz		
Number of Channels :	79		
Carrier Frequency of Each Channel :	2402+n*1 MHz; n=0~78		
Channel Spacing :	1 MHz		
Maximum Output Power to Antenna :	4.12 dBm		
Type of Antenna Connector :	N/A		
Antenna Type :	Chip Antenna		
Antenna Gain :	0 dBi		
Type of Modulation :	GFSK		
Function Type :	Transmitter		Transceiver V
DUT Stage :	Production Unit		

## 2. Test Configuration of Equipment under Test

### 2.1. Test Manner

- a. The EUT has been associated with peripherals pursuant to ANSI C63.4-2003 and configuration operated in a manner tended to maximize its emission characteristics in a typical application.
- b. For spurious emission below 1 GHz, only one channel of each application was tested because it is not related to channel selection.
- c. The EUT is programmed to transmit signal continuously for all tests.
- d. Frequency range investigated: conduction 150 KHz to 30 MHz, radiation 30 MHz to 25000 MHz.

### 2.2. Test Mode

Test Item	Test Mode
Radiated Emission / RF Conducted	Mode 1: BT Tx_CH00_2402 MHz Mode 2: BT Tx_CH39_2441 MHz Mode 3: BT Tx_CH78_2480 MHz
Conducted Emission	Mode 1 : BT Link + Adapter + iPod

### 2.3. Ancillary Equipment List

Item	Equipment	Trade Name	Model Name	FCC ID	Data Cable	Power Cord
1.	i-pod	Apple	A1199	DoC	Shielded, 1.2 m	N/A
2.	BT Mobile Phone	Philips	CT9A9R	RXSCT9A9R	N/A	N/A

## 2.4. Connection Diagram of Test System

### <Radiated Emission>

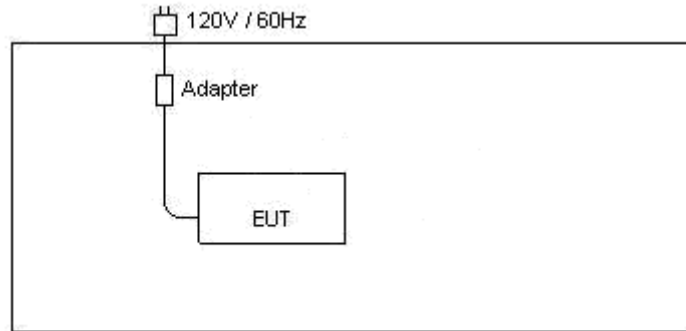

### <Conducted Emission>

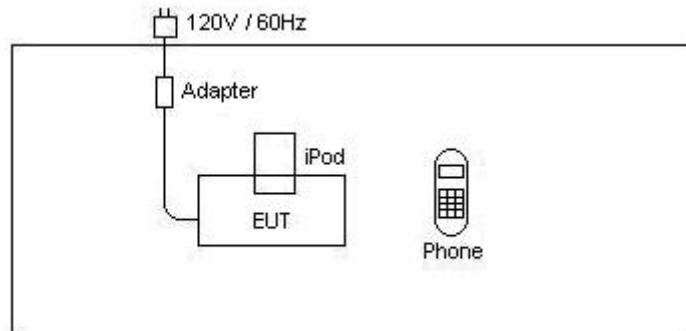

### 3. RF Utility

Programmed RF utility "Bluetest3" installed in EUT provides functions like channel selection and power level for continuous transmitting and receiving signal.

## 4. General Information of Test

Test Site Location : No. 52, Hwa Ya 1<sup>st</sup> Rd., Hwa Ya Technology Park,  
Kwei-Shan Hsiang, Tao Yuan Hsien, Taiwan, R.O.C.  
TEL : 886-3-327-3456  
FAX : 886-3-328-4978

Test Site No : CO04-HY, 03CH06-HY  
FCC Designation No : TW1022

### 4.1. Test Voltage

AC 120V / 60Hz

### 4.2. Standard for Methods of Measurement

ANSI C63.4-2003

### 4.3. Test Compliance

47 CFR Part 15 Subpart C

### 4.4. Frequency Range

- a. Conduction: from 150 KHz to 30 MHz
- b. Radiation: from 30 MHz to 25000MHz

### 4.5. Test Distance

The test distance of radiated emission from antenna to EUT is 3 m.



## 5. Report of Measurements and Examinations

### 5.1 List of Measurements and Examinations

The Emission Mode: Bluetooth

FCC Rule	Description of Test	Result
15.207	Conducted Emission	Pass
15.247(a)(1)(iii)	Hopping Channel Bandwidth	Pass
15.247(a)(1)	Hopping Channel Separation	Pass
15.247(a)(1)(iii)	Number of Hopping Frequency	Pass
15.247(a)(1)(iii)	Dwell Time of Each Frequency	Pass
15.247(b)(1)	Output Power	Pass
15.247(d)	100 KHz Bandwidth of Frequency Band Edges	Pass
15.209(a) 15.247(d)	Radiated Emission	Pass
15.203 15.247(b)(4)	Antenna Requirement	Pass

## 5.2 Bandwidth of Frequency Band Edges

### 5.2.1 Measuring Instruments

As described in chapter 6 of this test report.

### 5.2.2 Test Procedure

1. The transmitter output was connected to the spectrum analyzer via a low lose cable.
2. Set both RBW and VBW of spectrum analyzer to 100 KHz with suitable frequency span for the conducted measurement, and RBW/VBW=1MHz / 1MHz for peak measurement and RBW/VBW=1MHz / 300Hz for average measurement in the radiated measurement.
3. The band edges was measured and recorded.

### 5.2.3 Test Result

- Application Type : Bluetooth
- Temperature : 29~30°C
- Relative Humidity : 42~43%
- Test Engineer : Ken Hsu

Test Result in Bluetooth lower band	:	<b>PASS</b>
Test Result in Bluetooth higher band	:	<b>PASS</b>

5.2.4 Note on Band Edge Emission

CH00 (Horizontal)

Frequency ( MHz )	Level ( dBuV/m )	Over Limit ( dB )	Limit Line ( dBuV/m )	Read Level ( dBuV )	Antenna Factor ( dB )	Cable Loss ( dB )	Preamp Factor ( dB )	Ant Pos ( cm )	Table Pos ( deg )	Remark
2385.81	52.36	-21.64	74.00	52.26	31.86	3.92	35.68	100	0	Peak
2385.81	12.90	-41.10	54.00	12.80	31.86	3.92	35.68	103	356	Average

Remark:

<Delta Marker>

Delta marker at 1% RBW of span = 47.79 dB

Peak band edge at 2385.81 MHz (RBW = VBW = 1MHz) = 100.15 dBuV/m – 47.79 dB = 52.36 dBuV/m

Duty factor = 20 log (Package Transfer Times x Avg Hopping Channel) = 20 log (0.0031 x 3.2) = -39.46

Average band edge = Peak band edge + Duty factor = 52.36 dBuV/m + (-39.46) = 12.90 dBuV/m

CH00 (Vertical)

Frequency ( MHz )	Level ( dBuV/m )	Over Limit ( dB )	Limit Line ( dBuV/m )	Read Level ( dBuV )	Antenna Factor ( dB )	Cable Loss ( dB )	Preamp Factor ( dB )	Ant Pos ( cm )	Table Pos ( deg )	Remark
2385.81	51.45	-22.55	74.00	51.35	31.86	3.92	35.68	100	0	Peak
2385.81	11.99	-42.01	54.00	11.89	31.86	3.92	35.68	117	350	Average

Remark:

<Delta Marker>

Delta marker at 1% RBW of span = 47.79 dB

Peak band edge at 2385.81 MHz (RBW = VBW = 1MHz) = 99.24 dBuV/m – 47.79 dB = 51.45 dBuV/m

Duty factor = 20 log (Package Transfer Times x Avg Hopping Channel) = 20 log (0.0031 x 3.2) = -39.46

Average band edge = Peak band edge + Duty factor = 51.45 dBuV/m + (-39.46) = 11.99 dBuV/m

CH78 (Horizontal)

Frequency ( MHz )	Level ( dBuV/m )	Over Limit ( dB )	Limit Line ( dBuV/m )	Read Level ( dBuV )	Antenna Factor ( dB )	Cable Loss ( dB )	Preamp Factor ( dB )	Ant Pos ( cm )	Table Pos ( deg )	Remark
2483.50	55.16	-18.84	74.00	54.83	31.98	4.05	35.70	100	0	Peak
2483.50	15.70	-38.30	54.00	15.37	31.98	4.05	35.70	149	358	Average

Remark:

<Delta Marker>

Delta marker at 1% RBW of span = 46.31 dB

Peak band edge at 2483.50 MHz (RBW = VBW = 1MHz) = 101.47 dBuV/m – 46.31 dB = 55.16 dBuV/m

Duty factor = 20 log (Package Transfer Times x Avg Hopping Channel) = 20 log (0.0031 x 3.2) = -39.46

Average band edge = Peak band edge + Duty factor = 55.16 dBuV/m + (-39.46) dB = 15.70 dBuV/m

CH78 (Vertical)

Frequency ( MHz )	Level ( dBuV/m )	Over Limit ( dB )	Limit Line ( dBuV/m )	Read Level ( dBuV )	Antenna Factor ( dB )	Cable Loss ( dB )	Preamp Factor ( dB )	Ant Pos ( cm )	Table Pos ( deg )	Remark
2483.50	51.69	-22.31	74.00	51.36	31.98	4.05	35.70	100	0	Peak
2483.50	12.23	-41.77	54.00	11.90	31.98	4.05	35.70	154	330	Average

Remark:

<Delta Marker>

Delta marker at 1% RBW of span = 46.31 dB

Peak band edge at 2483.50 MHz (RBW = VBW = 1MHz) = 98 dBuV/m – 46.31 dB = 51.69 dBuV/m

Duty factor = 20 log (Package Transfer Times x Avg Hopping Channel) = 20 log (0.0031 x 3.2) = -39.46

Average band edge = Peak band edge + Duty factor = 51.69 dBuV/m + (-39.46) dB = 12.23 dBuV/m

### 5.3 Hopping Channel Separation

#### 5.3.1 Measuring Instruments

As described in chapter 6 of this test report.

#### 5.3.2 Test Procedure

- a. The output of EUT was connected to the spectrum analyzer by a low loss cable..
- b. Set RBW of spectrum analyzer to 30 KHz and VBW to 100 KHz.
- c. The Hopping Channel Separation is defined as the channel is separated with the next channel.

#### 5.3.3 Test Setup Layout

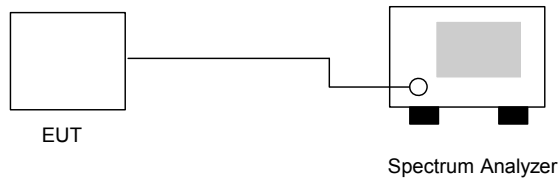

#### 5.3.4 Test Result

- Temperature: 29~30°C
- Relative Humidity: 42~43%
- Test Engineer: Ken Hsu

Channel	Frequency (MHz)	Carrier Frequency Separation ( MHz )	Limits ( MHz )	Plot Ref. No.
00	2402	1.000	0.525	Mode 1
39	2441	1.000	0.523	Mode 2
78	2480	1.000	0.525	Mode 3

Remark: Hopping Channel Separation shall be greater 2/3 of 20dB bandwidth.

5.3.5 Hopping Channel Separation

Mode 1: CH00 (2402MHz)

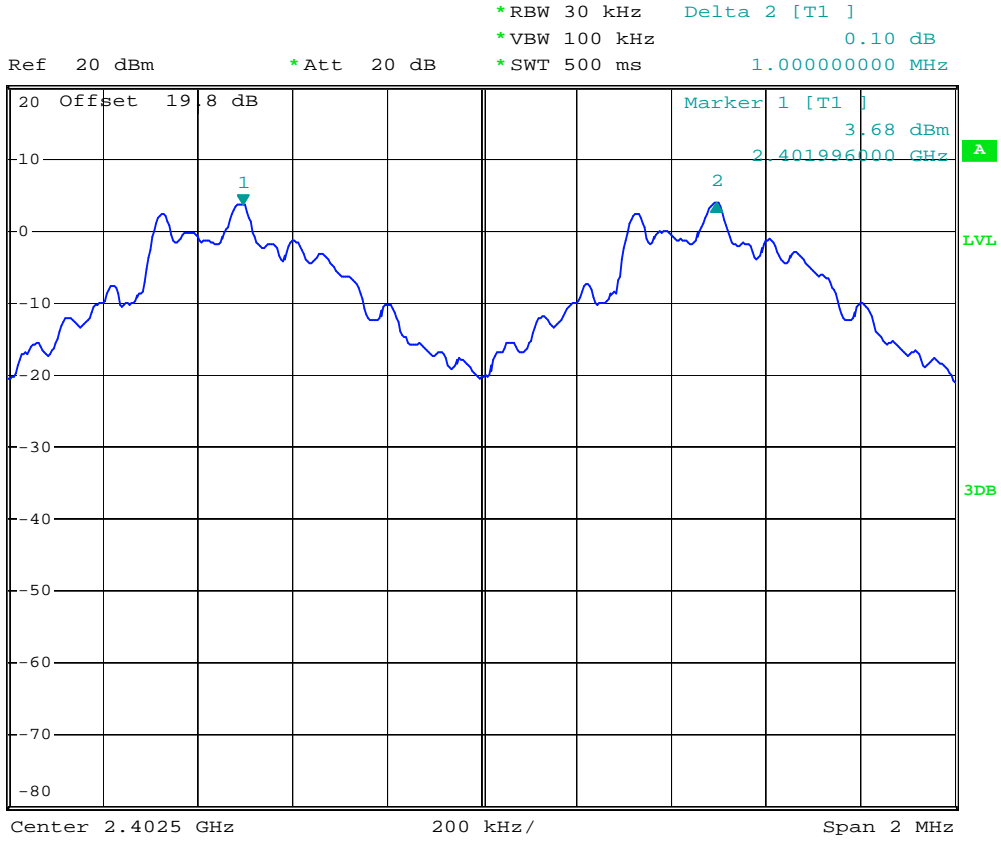

Date: 22.JUL.2008 15:03:00

Mode 2: CH39 (2441MHz)

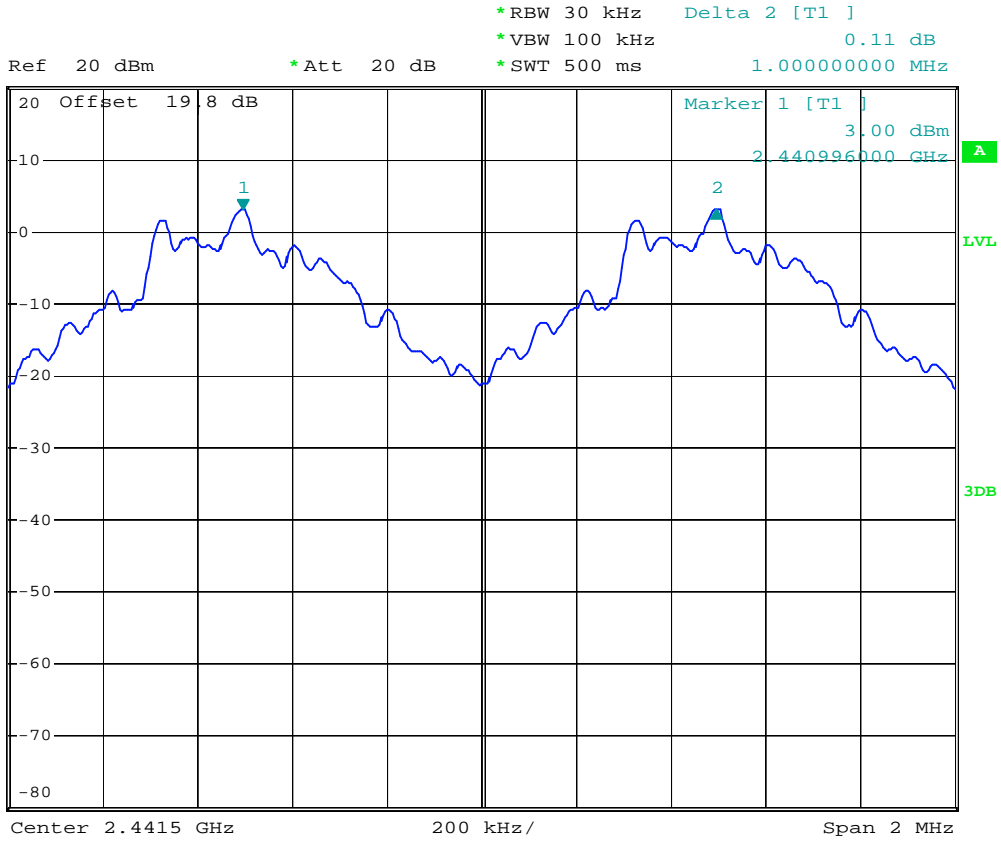

Date: 22.JUL.2008 15:04:17

Mode 3: CH78 (2480MHz)

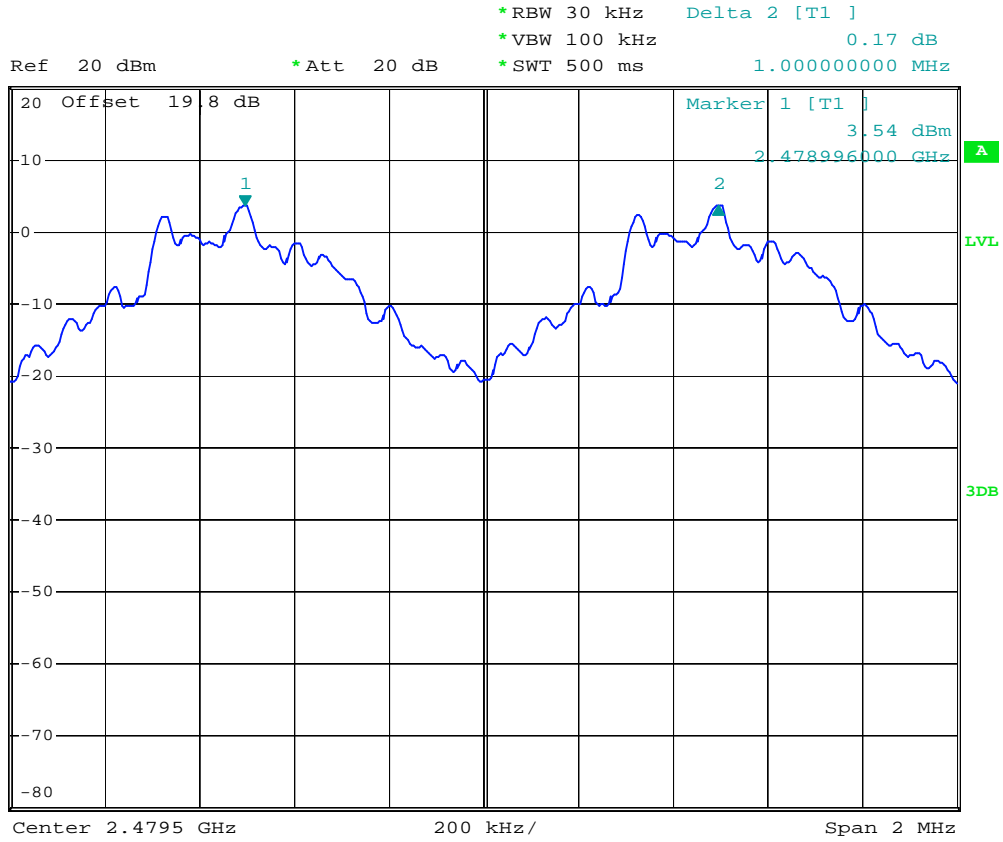

Date: 22.JUL.2008 15:05:15



## 5.4 Number of Hopping Frequency

### 5.4.1 Measuring Instruments

As described in chapter 6 of this test report.

### 5.4.2 Test Procedure

- a. The transmitter output was connected to the spectrum analyzer directly.
- b. Set RBW of spectrum analyzer to 100 KHz and VBW to 100 KHz.
- c. The number of hopping frequency used is defined as the device has the numbers of total channel.

### 5.4.3 Test Setup Layout

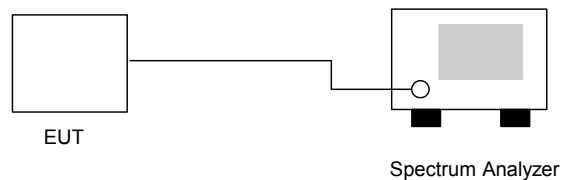

### 5.4.4 Test Result

- Temperature: 29~30°C
- Relative Humidity: 42~43%
- Test Engineer: Ken Hsu

Number of Hopping Frequency (Channel)	Limits (Channel)
79	15

5.4.5 Number of Hopping Frequency



\* RBW 100 kHz  
\* VBW 100 kHz  
\* SWT 500 ms

Ref 20 dBm

\* Att 20 dB

1 PK  
MAXH

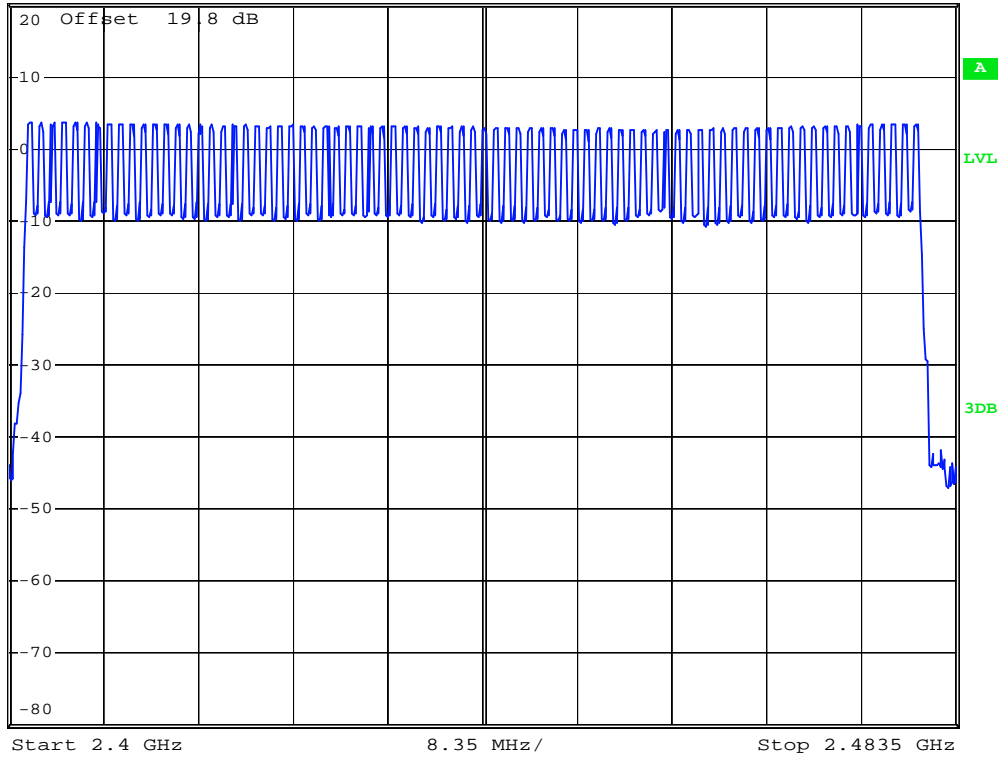

Date: 22.JUL.2008 15:28:13

## 5.5 Hopping Channel Bandwidth

### 5.4.1 Measuring Instruments

As described in chapter 6 of this test report.

### 5.4.2 Test Procedure

- a. The transmitter output was connected to the spectrum analyzer by a low loss cable.
- b. Set RBW of spectrum analyzer to 30 KHz and VBW to 300 KHz.
- c. The Hopping Channel bandwidth is defined as the total spectrum the power of which is higher than peak power minus 20 dB.

### 5.4.3 Test Setup Layout

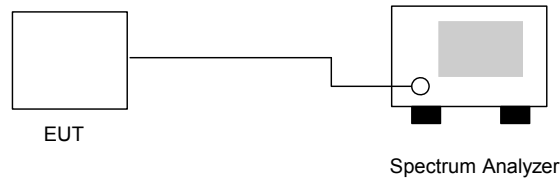

### 5.4.4 Test Result

- Temperature: 29~30°C
- Relative Humidity: 42~43%
- Test Engineer: Ken Hsu

Channel	Frequency (MHz)	Hopping Channel Bandwidth (MHz)	Plot Ref. No.
00	2402	0.788	Mode 1
39	2441	0.784	Mode 2
78	2480	0.788	Mode 3

5.4.5 Hopping Channel Bandwidth

Mode 1: CH00 (2402MHz)

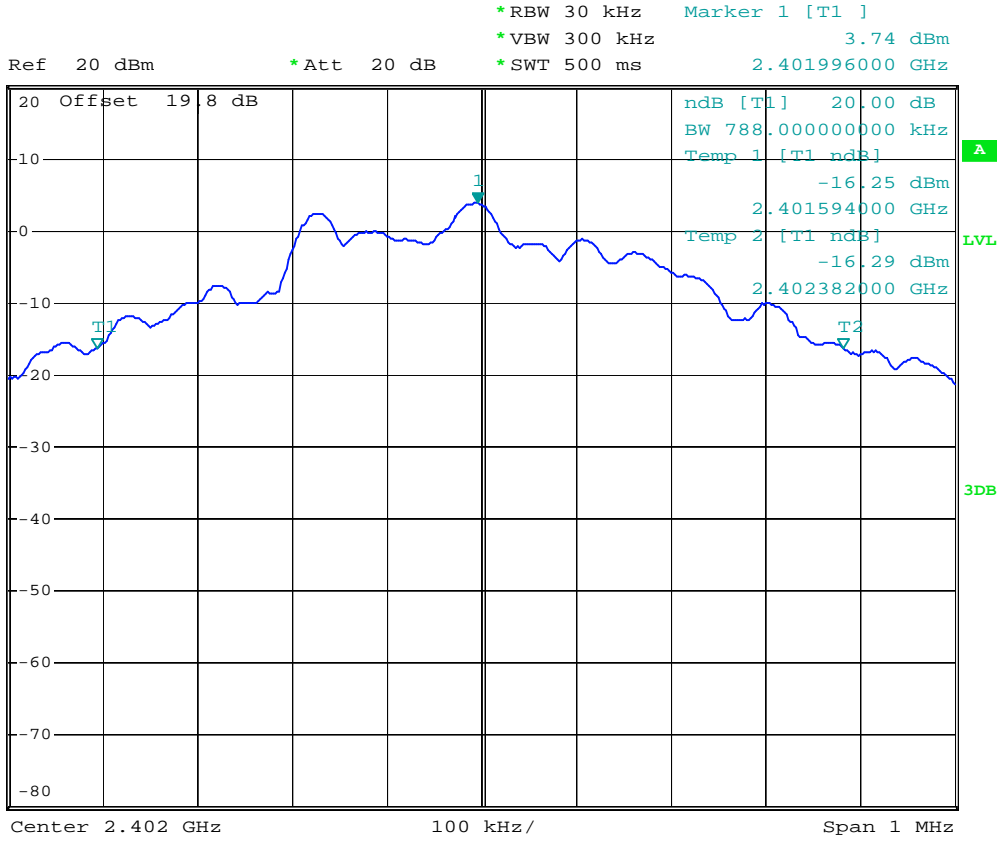

Date: 22.JUL.2008 14:57:00

Mode 2: CH39 (2441MHz)

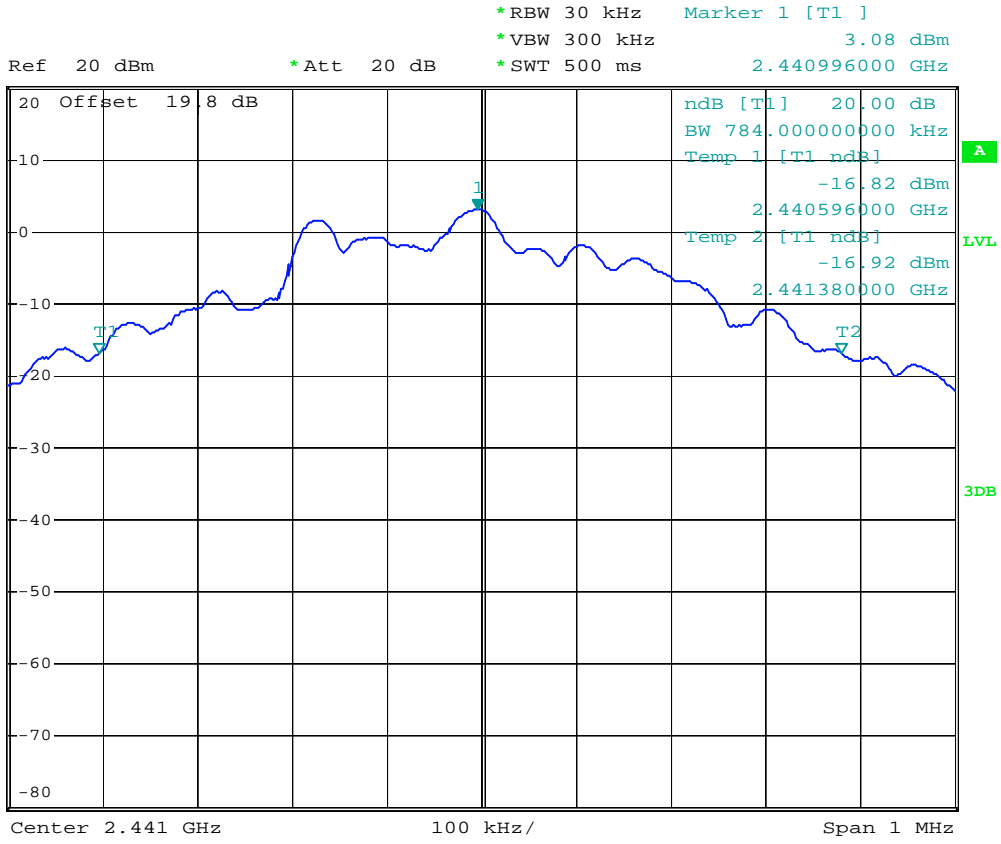

Date: 22.JUL.2008 14:57:24

Mode 3: CH78 (2480MHz)

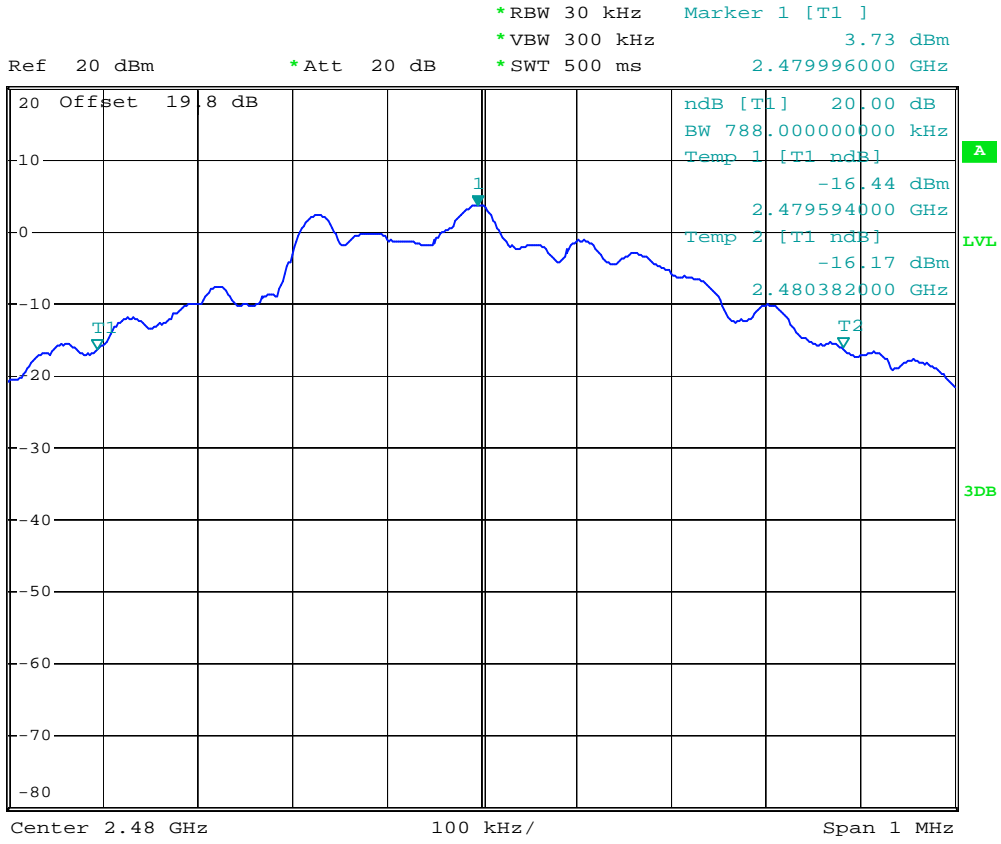

Date: 22.JUL.2008 14:57:43

### 5.6 Dwell Time of Each Frequency within a 30 Seconds Period

#### 5.6.1 Measuring Instruments

As described in chapter 6 of this test report.

#### 5.6.2 Test Procedure

1. The transmitter output was connected to the spectrum analyzer by a low loss cable.
2. Set RBW of spectrum analyzer to 1MHz and VBW to 1MHz.
3. Set the center frequency on any frequency would be measure and set the frequency span to zero span.
4. The calculate =  $79 * 0.4 * (1600/79) * t$  (t = the time duration of one single pulse )

#### 5.6.3 Test Setup Layout

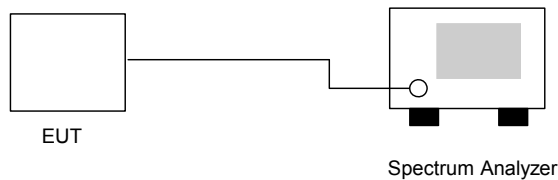

#### 5.6.4 Test Result

- Temperature: 29~30°C
- Relative Humidity: 42~43%
- Test Engineer: Ken Hsu

Package Mode	Average Hopping Channel	Package Transfer Time (us)	Dwell Time (s)	Limit (s)
DH1	10.00	460.00	0.145	0.4
DH3	5.00	1740.00	0.275	0.4
DH5	3.50	3040.00	0.336	0.4

※ Remark:

1. Dwell Time =  $79(\text{channels}) \times 0.4(\text{s}) \times \text{average hopping channel} \times \text{package transfer time}$
2. 79 channels come from the Hopping Channel number.
3. Average Hopping Channel = hops/sweep time
4. t: Package Transfer Time(us)

5.6.5 Dwell Time

DH1 (CH39)

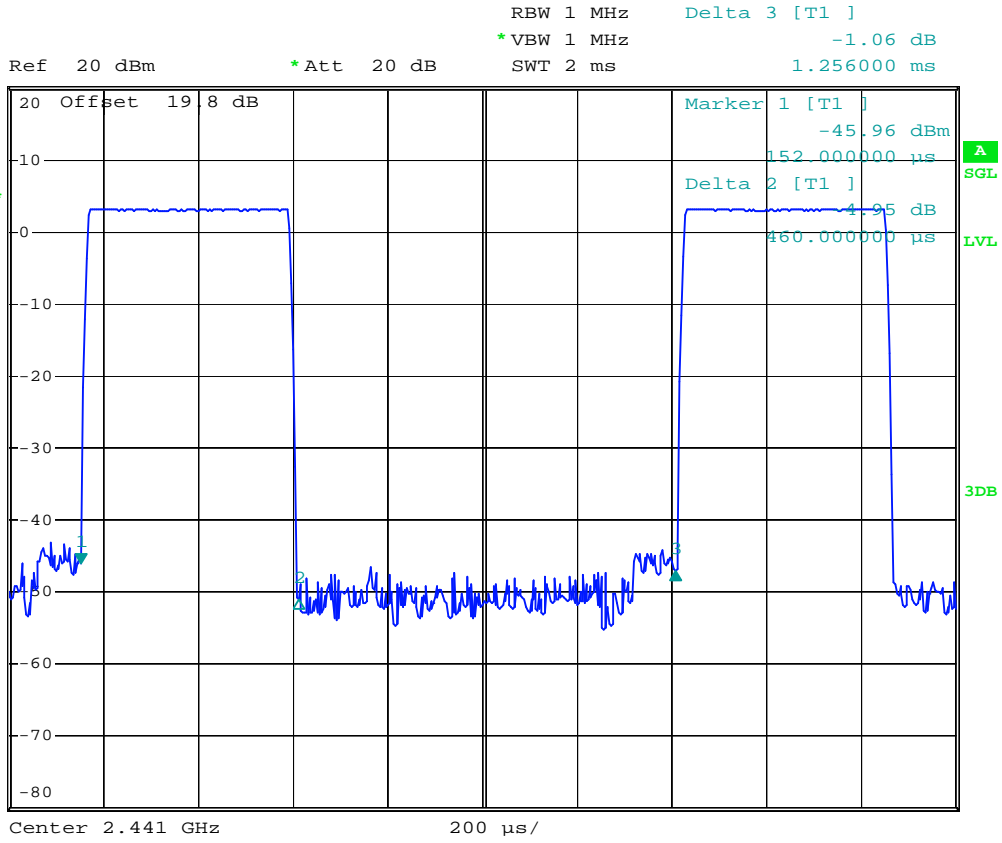

Date: 22.JUL.2008 15:07:59





Ref 20 dBm      \*Att 20 dB      RBW 1 MHz  
 \*VBW 1 MHz      SWT 10 s

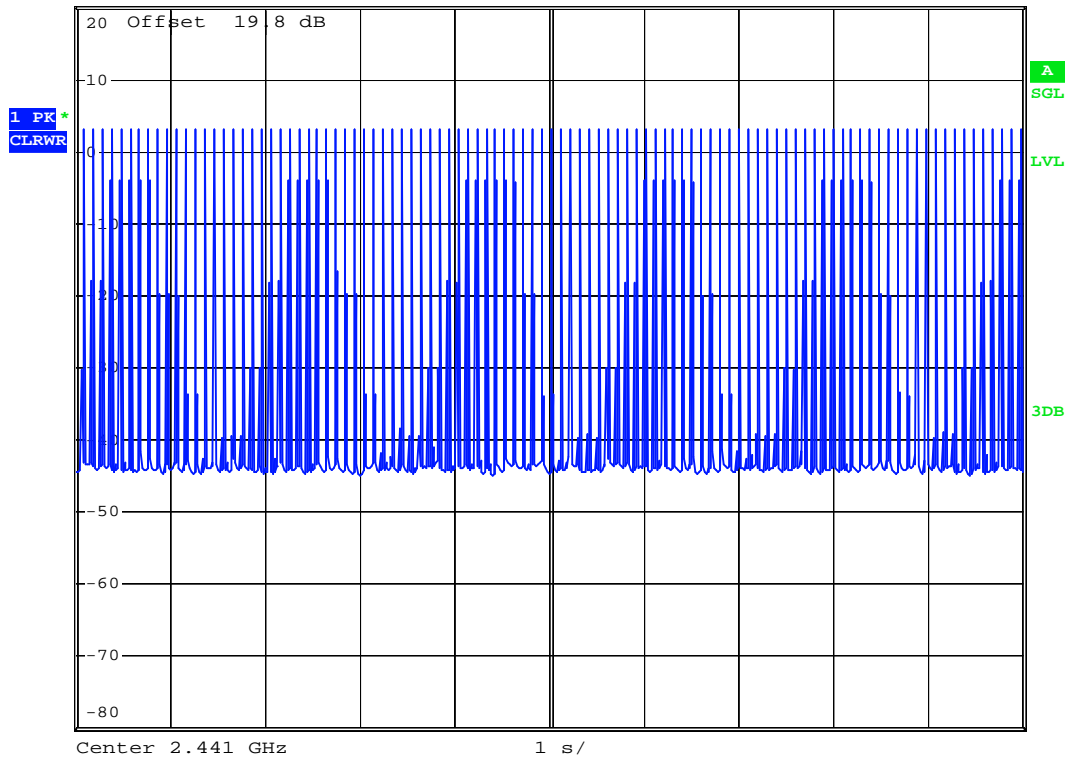

Date: 22.JUL.2008 15:15:13

DH3 (CH39)

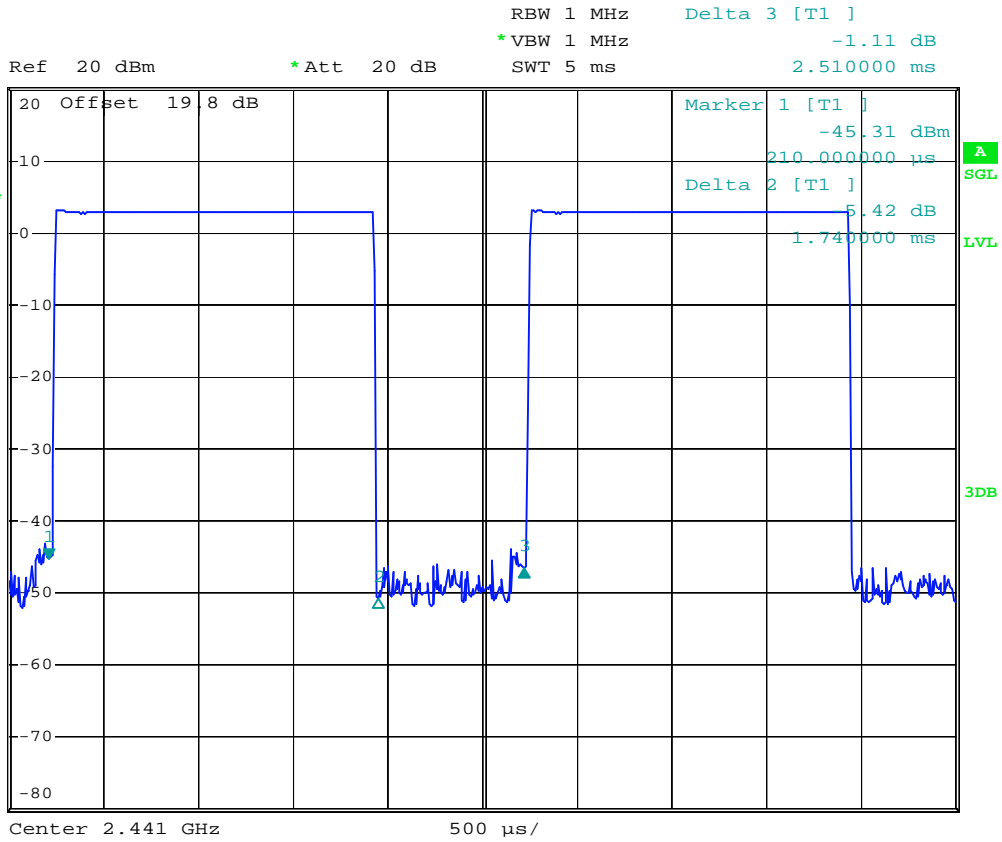

Date: 22.JUL.2008 15:09:12



Ref 20 dBm      \*Att 20 dB      RBW 1 MHz  
 \*VBW 1 MHz  
 SWT 10 s

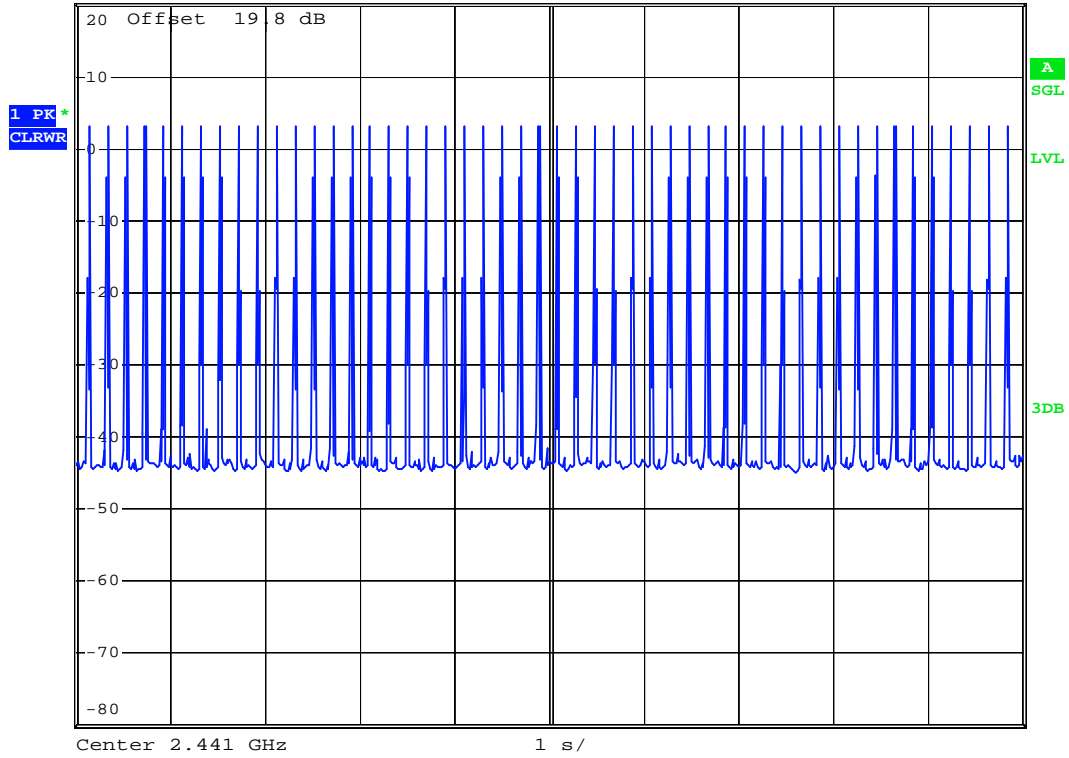

Date: 22.JUL.2008 15:13:28

DH5 (CH39)

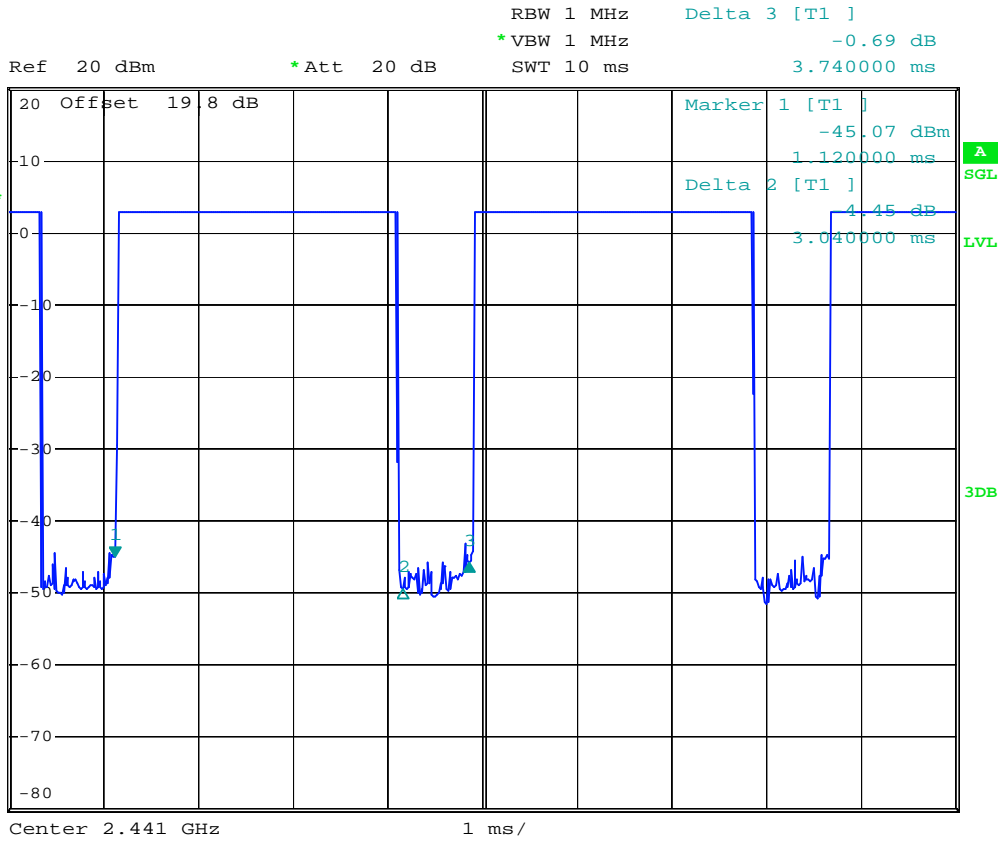

Date: 22.JUL.2008 15:32:17



Ref 20 dBm      \*Att 20 dB      RBW 1 MHz  
 \*VBW 1 MHz  
 SWT 10 s

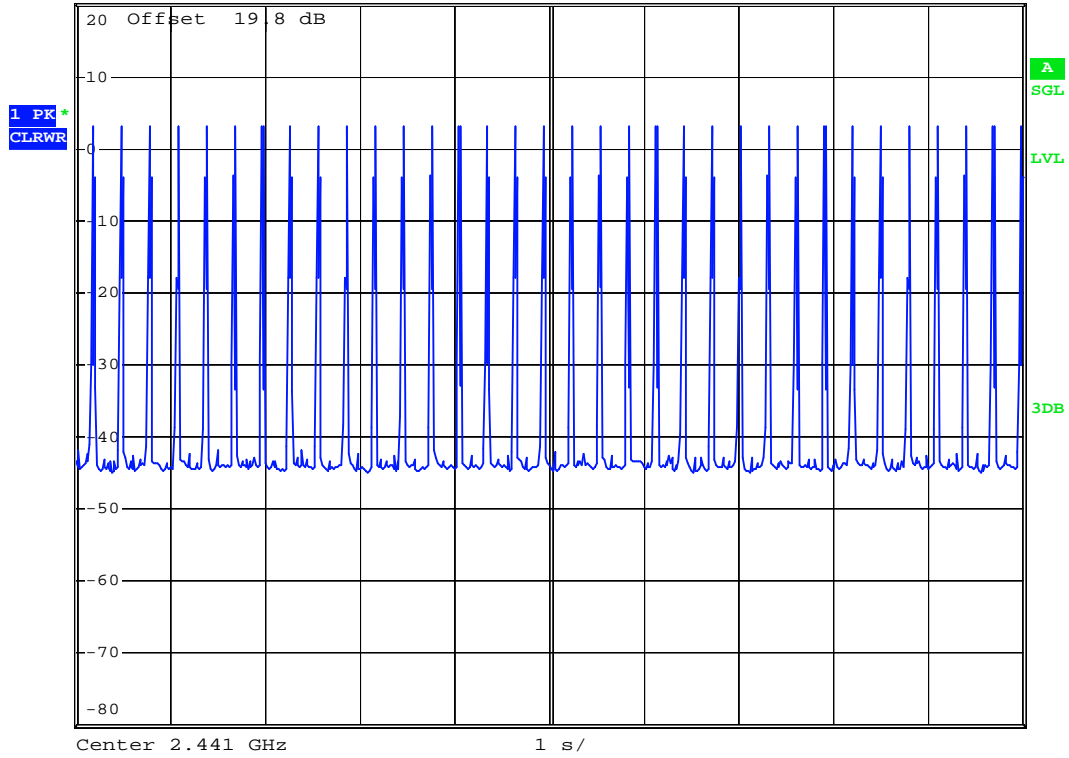

Date: 22.JUL.2008 15:10:53

## 5.7 Peak Output Power Measurement

### 5.7.1 Measuring Instruments

As described in chapter 6 of this test report.

### 5.7.2 Test Procedure

The antenna port (RF output) of the EUT was connected to the input (RF input) of a spectrum analyzer for Bluetooth measurement. RBW and VBW are set to 3MHz. The cable loss has been offset before testing.

### 5.7.3 Test Setup Layout

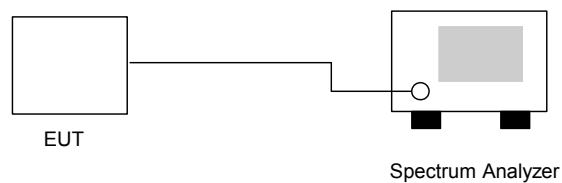

### 5.7.4 Test Result

- Temperature: 29~30°C
- Relative Humidity: 42~43%
- Test Engineer: Ken Hsu

Channel	Frequency (MHz)	Measured Output Power (dBm)	Limits (dBm)
00	2402	4.12	30
39	2441	3.44	30
78	2480	4.01	30

5.7.5 Output Power

Mode 1: CH00 (2402MHz)

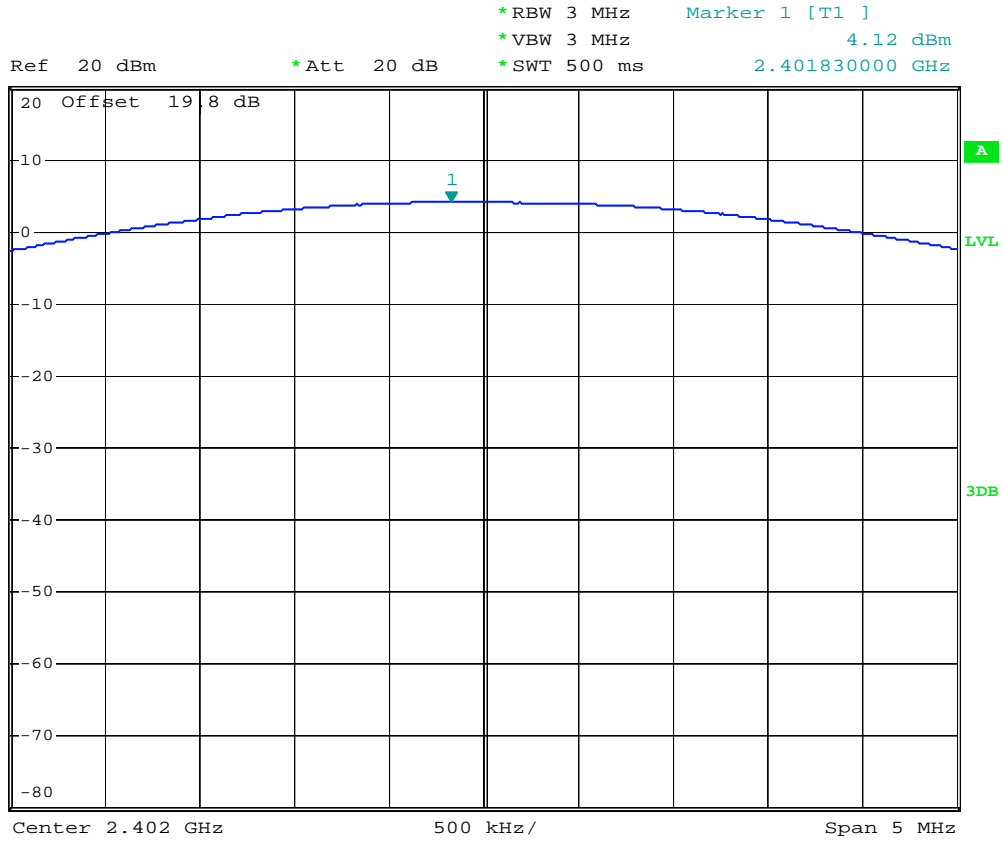

Date: 22.JUL.2008 14:43:27

Mode 2: CH39 (2441MHz)

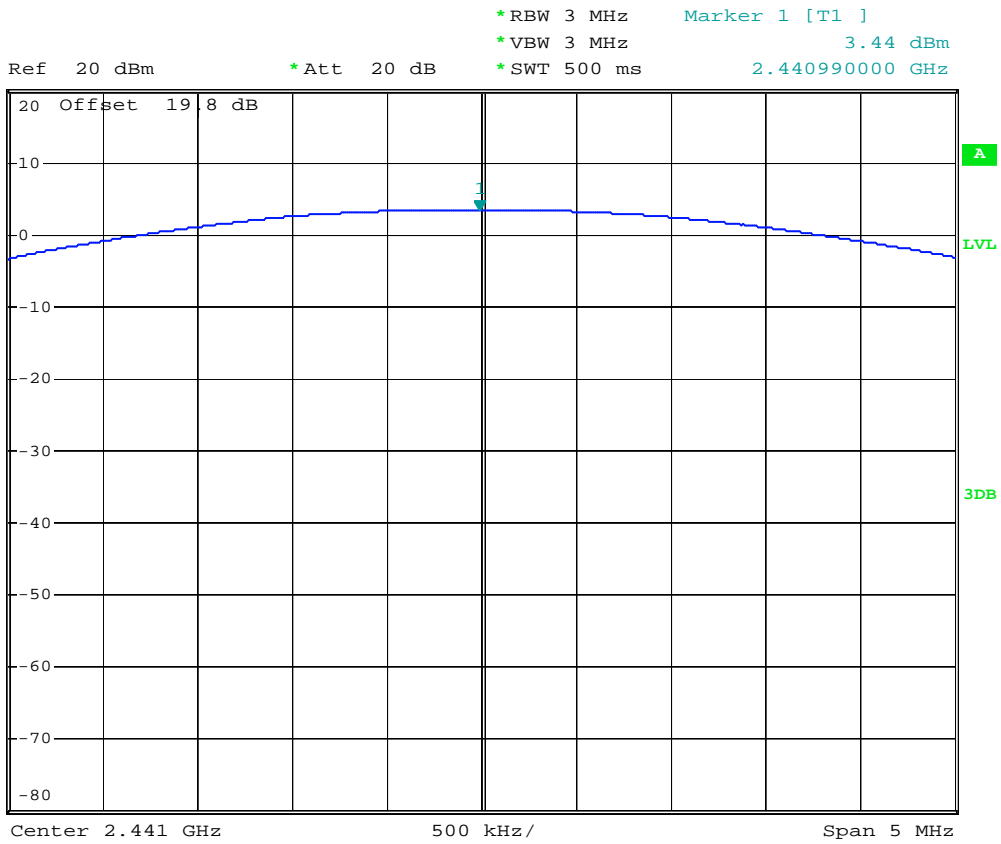

Date: 22.JUL.2008 14:43:48



Mode 3: CH78 (2480MHz)

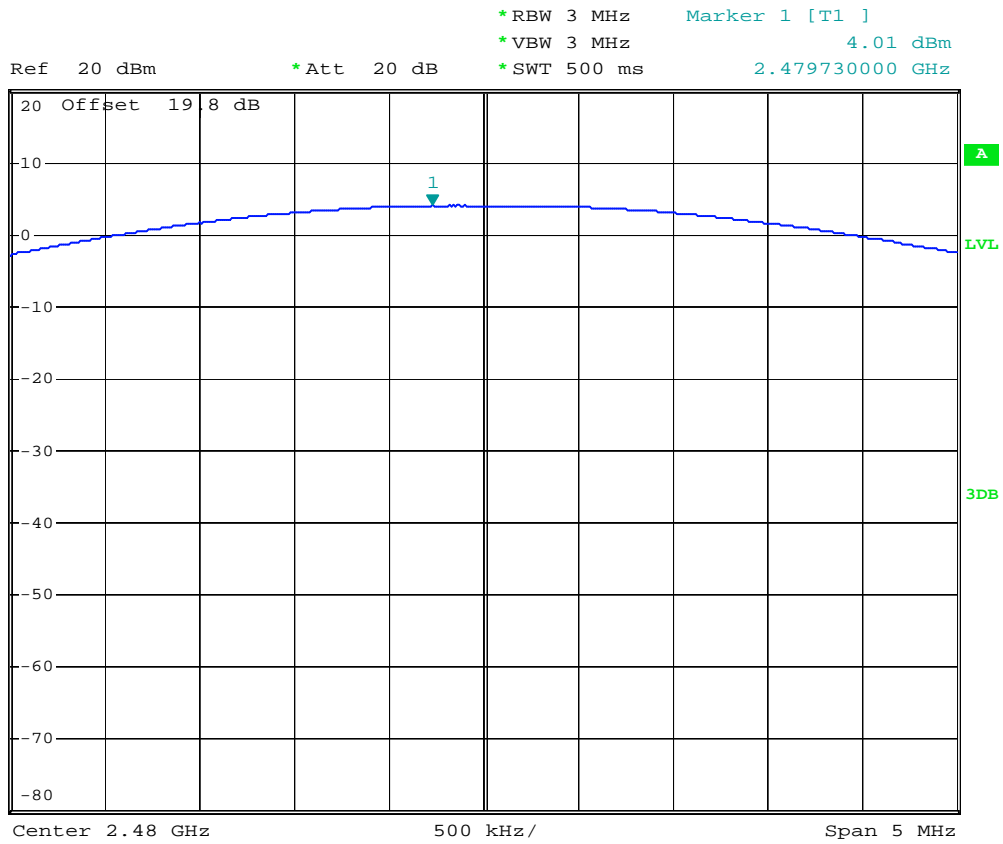

Date: 22.JUL.2008 14:44:03

## **5.8 Conducted Emission**

### **5.8.1 Measuring Instruments**

As described in chapter 6 of this test Report.

### **5.8.2 Test Procedures**

1. The EUT was placed 0.4 meter from the conducting wall of the shielding room was kept at least 80 centimeters from any other grounded conducting surface.
2. Connect EUT to the power port of a line impedance stabilization network (LISN).
3. All the support units are connected to the other LISN.
4. The LISN provides 50 ohm coupling impedance for the measuring instrument.
5. The FCC states that a 50 ohm, 50 microhenry LISN should be used.
6. Both sides of AC line were checked for maximum conducted interference.
7. The frequency range from 150 KHz to 30 MHz was searched.
8. Set the test-receiver system to Peak Detect Function and specified bandwidth with Maximum Hold Mode.

5.8.3 Test Data

- Test Mode : Mode 1
- Temperature : 29~30°C
- Relative Humidity : 42~43%
- Test Engineer : Cona Huang
- Test Condition : Line

**The test that passed at minimum margin was marked by the frame in the following table.**

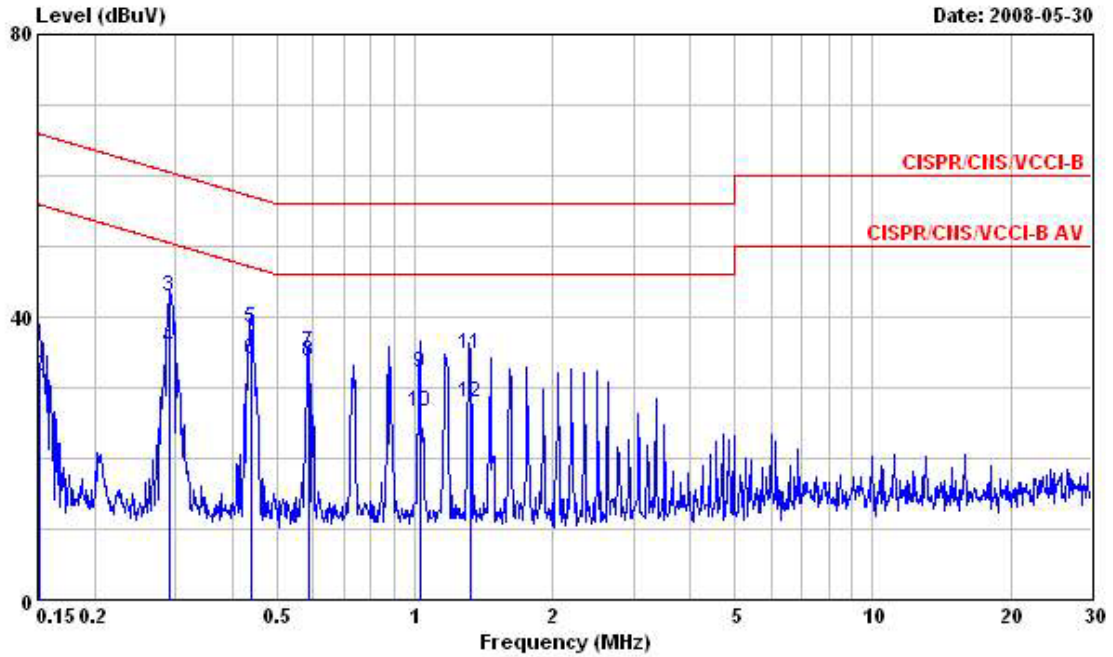

Site : CO04-HY  
 Condition : CISPR/CNS/VCCI-B LISN 2008 0416 99041 LINE  
 EUT : Bluetooth Speaker  
 POWER: 120V/60Hz  
 Model : FR 843009  
 Memo : Model

	Freq	Level	Over	Limit	Read	LISN	Cable	Remark
	MHz	dBuV	Limit	Line	Level	Factor	Loss	
			dB	dBuV	dBuV	dB	dB	
1	0.1515980	33.44	-32.47	65.91	33.32	0.09	0.03	QP
2	0.1515980	31.46	-24.45	55.91	31.34	0.09	0.03	Average
3	0.2924290	43.02	-17.44	60.46	42.88	0.10	0.04	QP
4	0.2924290	35.51	-14.95	50.46	35.37	0.10	0.04	Average
5	0.4397440	38.51	-18.56	57.07	38.35	0.10	0.06	QP
6	@0.4397440	34.01	-13.06	47.07	33.85	0.10	0.06	Average
7	0.5854040	35.07	-20.93	56.00	34.93	0.10	0.04	QP
8	@0.5854040	33.60	-12.40	46.00	33.46	0.10	0.04	Average
9	1.030	32.20	-23.80	56.00	32.07	0.11	0.02	QP
10	1.030	26.61	-19.39	46.00	26.48	0.11	0.02	Average
11	1.320	34.76	-21.24	56.00	34.61	0.12	0.03	QP
12	1.320	28.02	-17.98	46.00	27.87	0.12	0.03	Average

• Test Condition: Neutral

■ The test that passed at minimum margin was marked by the frame in the following table.

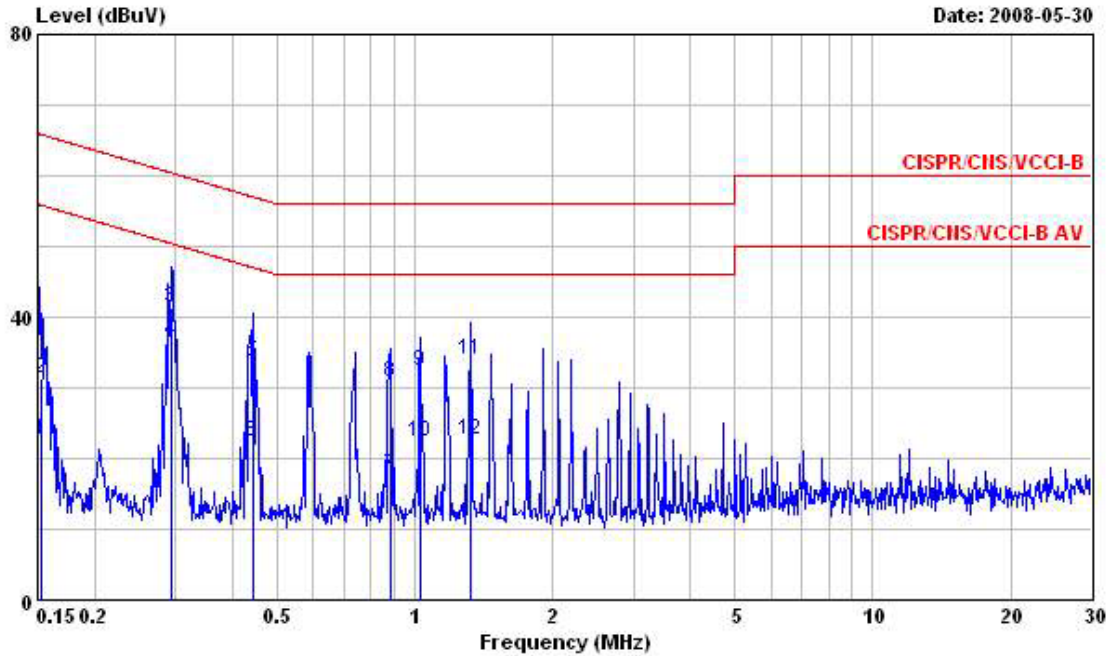

Site : CO04-HY  
 Condition : CISPR/CIS/VCCI-B LISN 2008 0416 99041 NEUTRAL  
 EUT : Bluetooth Speaker  
 POWER: 120V/60Hz  
 Model : FR 843009  
 Memo : Model

	Freq	Level	Over Limit	Limit Line	Read Level	LISN Factor	Cable Loss	Remark
	MHz	dBuV	dB	dBuV	dBuV	dB	dB	
1	0.1532130	22.53	-33.29	55.82	22.41	0.09	0.03	Average
2	0.1532130	31.36	-34.46	65.82	31.24	0.09	0.03	QP
3	0.2939830	41.32	-19.09	60.41	41.19	0.09	0.04	QP
4	0.2939830	36.57	-13.84	50.41	36.44	0.09	0.04	Average
5	0.4444290	33.64	-23.34	56.98	33.49	0.09	0.06	QP
6	0.4444290	22.41	-24.57	46.98	22.26	0.09	0.06	Average
7	0.8849860	17.74	-28.26	46.00	17.60	0.11	0.03	Average
8	0.8849860	30.66	-25.34	56.00	30.52	0.11	0.03	QP
9	1.030	32.33	-23.67	56.00	32.20	0.11	0.02	QP
10	1.030	22.27	-23.73	46.00	22.14	0.11	0.02	Average
11	1.320	33.83	-22.17	56.00	33.69	0.11	0.03	QP
12	1.320	22.70	-23.30	46.00	22.56	0.11	0.03	Average

## **5.9 Radiated Emission Measurement**

### **5.9.1 Measuring Instruments**

As described in chapter 6 of this Report.

### **5.9.2 Test Procedures**

1. The EUT was placed on a rotatable table top 0.8 meter above ground.
2. The EUT was set 3 meters from the interference receiving antenna which was mounted on the top of a variable height antenna tower.
3. The table was rotated 360 degrees to determine the position of the highest radiation.
4. The antenna is a broadband antenna and its height is varied between one meter and four meters above ground to find the maximum value of the field strength for both horizontal polarization and vertical polarization of the antenna.
5. For each suspected emission, the EUT was arranged to its worst case and then tune the antenna tower (from 1 m to 4 m) and turntable (from 0 degree to 360 degrees) to find the maximum reading.
6. Set the test-receiver system to Peak or CISPR quasi-peak Detect Function and specified bandwidth with Maximum Hold Mode.
7. For testing below 1GHz, If the emission level of the EUT in peak mode was 3 dB lower than the limit specified, then testing will be stopped and peak values of EUT will be reported, otherwise, the emissions will be repeated one by one using the quasi-peak method and reported.
8. For testing above 1GHz, the emission level of the EUT in peak mode was 20dB lower than average limit (that means the emission level in average mode also complies with the limit in average mode), then testing will be stopped and peak values of EUT will be reported, otherwise, the emissions will be measured in average mode again and reported.

5.9.3 Typical Test Setup Layout of Radiated Emission

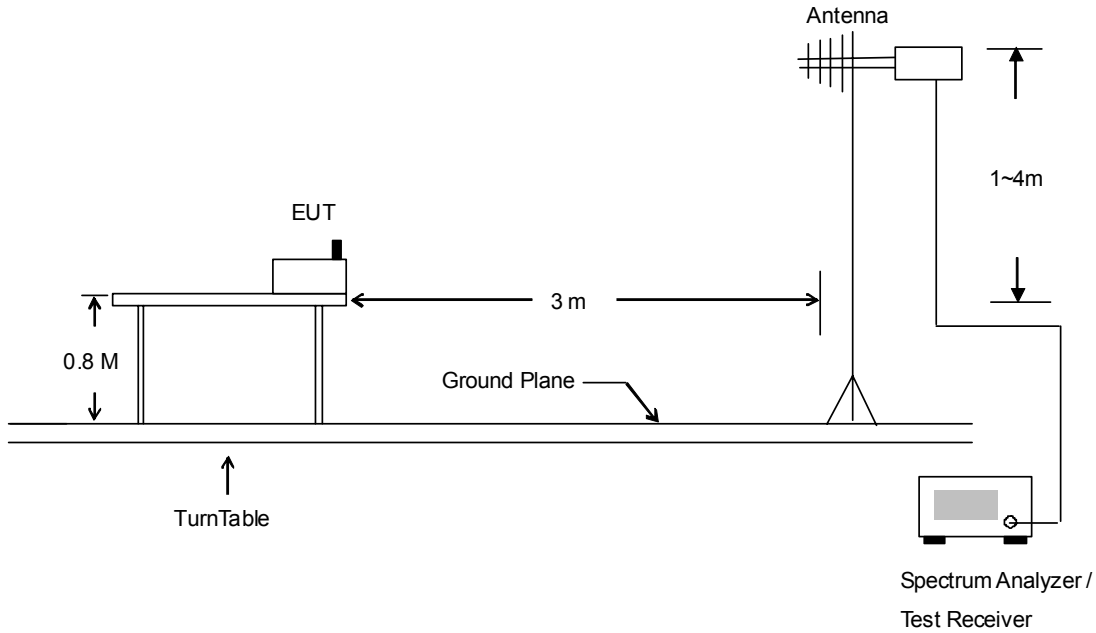

5.9.4 Test Data

- Test Mode : Mode 1
- Temperature : 21~26°C
- Relating Humidity : 49~57%
- Test Engineer : Sun Wang
- Polarization : Horizontal (30MHz-1GHz)

■ The test that passed at minimum margin was marked by the boldface in the following table.

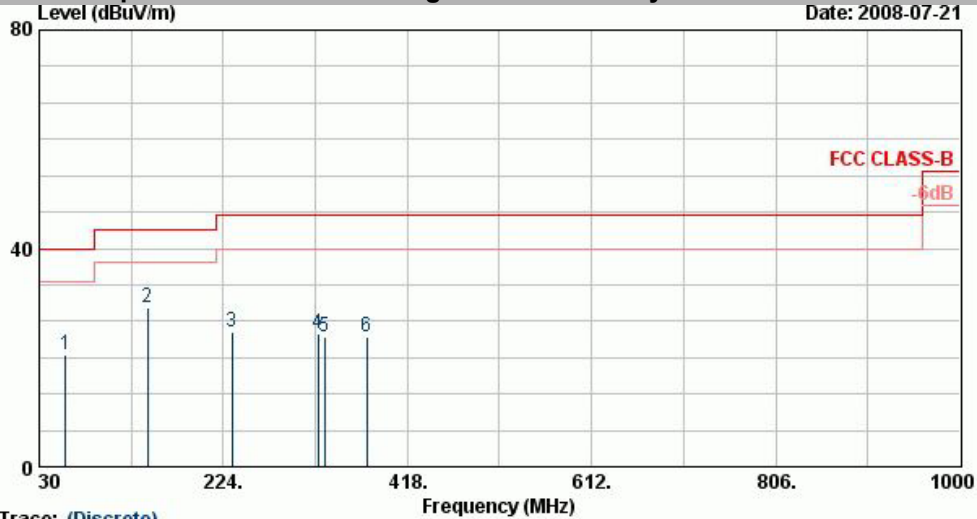

Trace: (Discrete)  
 Site : 03CH06-HY  
 Condition : FCC CLASS-B 3m LF-ANT(951121) HORIZONTAL  
 EUT : Bluetooth Speaker  
 Power : 120Vac/60Hz  
 Model : FR 843009  
 Memo : Mode 1  
 Data Rate : DR5

	Freq	Level	Over Limit	Limit Line	ReadAntenna	Cable	Preamp	Ant	Table	Remark	
	MHz	dBuV/m	dB	dBuV/m	dBuV	dB/m	dB	dB	cm	deg	
1	58.08	20.44	-19.56	40.00	45.12	6.91	0.40	31.99	---	---	Peak
2	144.48	29.24	-14.26	43.50	50.08	10.32	0.55	31.71	100	207	Peak
3	233.04	24.65	-21.35	46.00	44.67	11.24	0.70	31.97	---	---	Peak
4	323.80	24.35	-21.65	46.00	41.65	13.83	0.80	31.93	---	---	Peak
5	330.80	23.72	-22.28	46.00	40.79	14.00	0.80	31.87	---	---	Peak
6	374.90	23.66	-22.34	46.00	39.47	15.14	0.85	31.79	---	---	Peak

• Polarization : Horizontal (1GHz-25GHz)

■ The test that passed at minimum margin was marked by the boldface in the following table.

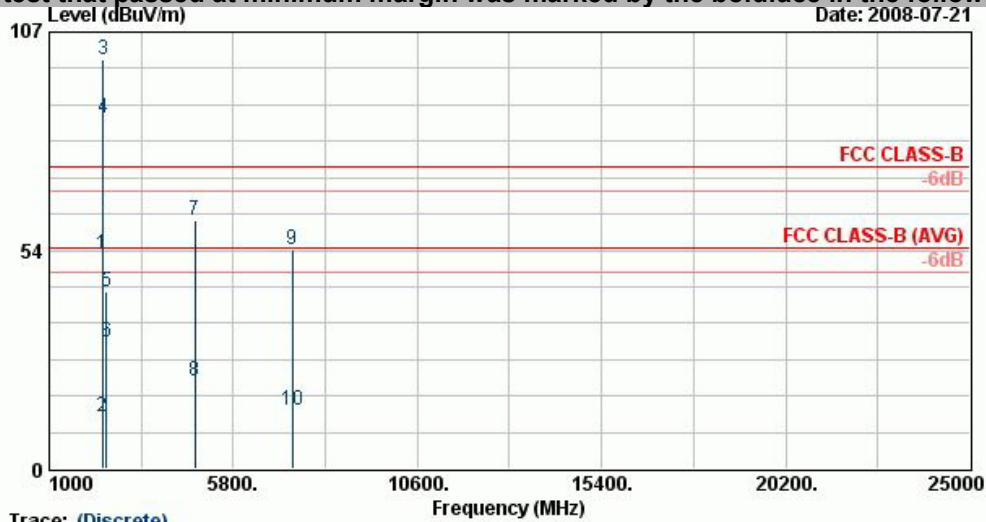

Trace: (Discrete)  
 Site : 03CH06-HY  
 Condition : FCC CLASS-B 3m SHF-EHF HORN HORIZONTAL  
 EUT : Bluetooth Speaker  
 Power : 120Vac/60Hz  
 Model : FR 843009  
 Memo : Mode 1  
 Data Rate : DR5

	Freq	Level	Over	Limit	Read	Antenna	Cable	Preamp	Ant	Table	Remark
	MHz	dBuV/m	Limit	Line	Level	Factor	Loss	Factor	Pos	Pos	
			dB	dBuV/m	dBuV	dB/m	dB	dB	cm	deg	
1	2385.81	52.36	-21.64	74.00	52.26	31.86	3.92	35.68	100	0	Peak
2	2385.81	12.90	-41.10	54.00	12.80	31.86	3.92	35.68	103	356	Average
3 X	2402.00	100.15			100.03	31.88	3.92	35.68	100	0	Peak
4 @	2402.00	85.79			85.69	31.86	3.92	35.68	103	356	Average
5	2484.00	43.44	-30.56	74.00	43.11	31.98	4.05	35.70	100	0	Peak
6	2484.00	30.98	-23.02	54.00	30.65	31.98	4.05	35.70	103	356	Average
7	4806.00	60.76	-13.24	74.00	56.55	34.12	5.77	35.68	100	0	Peak
8	4806.00	21.30	-32.70	54.00	17.09	34.12	5.77	35.68	100	297	Average
9	7341.00	53.59	-20.41	74.00	46.86	35.66	7.21	36.14	100	0	Peak
10	7341.00	14.13	-39.87	54.00	7.40	35.66	7.21	36.14	100	270	Average

Remark: #3 and #4 are Fundamental Signals.



• Polarization : Vertical (30MHz-1GHz)

■ The test that passed at minimum margin was marked by the boldface in the following table.

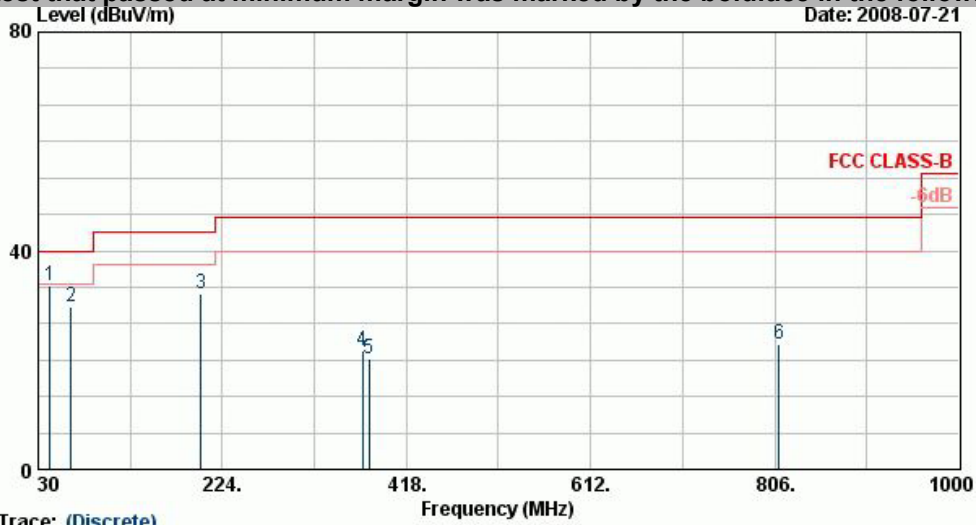

Trace: (Discrete)

Site : 03CH06-HY  
 Condition : FCC CLASS-B 3m LP-ANT(951121) VERTICAL  
 EUT : Bluetooth Speaker  
 Power : 120Vac/60Hz  
 Model : FR 843009  
 Memo : Mode 1  
 Data Rate : DR5

	Freq	Level	Over	Limit	Read	Antenna	Cable	Preamp	Ant	Table	Remark
	MHz	dBuV/m	Limit	Line	Level	Factor	Loss	Factor	Pos	Pos	
			dB	dBuV/m	dBuV	dB/m	dB	dB	cm	deg	
1	42.69	33.70	-6.30	40.00	53.09	12.02	0.30	31.71	100	104	Peak
2	64.83	29.67	-10.33	40.00	54.46	6.76	0.40	31.94	---	---	Peak
3	201.18	32.21	-11.29	43.50	54.37	9.36	0.60	32.12	---	---	Peak
4	371.40	21.58	-24.42	46.00	37.50	15.04	0.81	31.78	---	---	Peak
5	378.40	20.29	-25.71	46.00	35.99	15.22	0.88	31.80	---	---	Peak
6	810.30	22.95	-23.05	46.00	34.08	19.89	1.20	32.22	---	---	Peak

• Polarization : Vertical (1GHz-25GHz)

■ The test that passed at minimum margin was marked by the boldface in the following table.

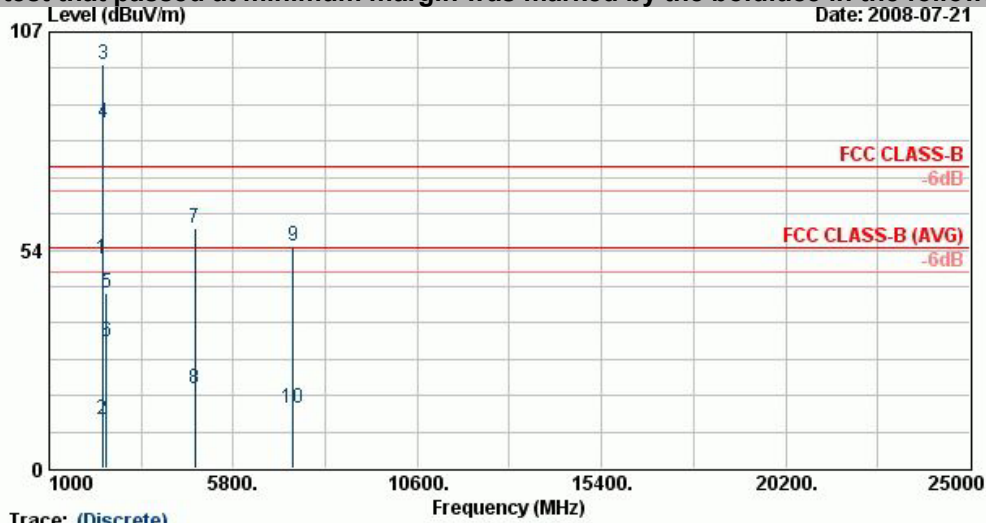

Trace: (Discrete)  
 Site : 03CH06-HY  
 Condition : FCC CLASS-B 3m SHF-EHF HORN VERTICAL  
 EUT : Bluetooth Speaker  
 Power : 120Vac/60Hz  
 Model : FR 843009  
 Memo : Mode 1  
 Data Rate : DR5

	Freq	Level	Over	Limit	Read	Antenna	Cable	Preamp	Ant	Table	Remark
	MHz	dBuV/m	Limit	Line	Level	Factor	Loss	Factor	Pos	Pos	
			dB	dBuV/m	dBuV	dB/m	dB	dB	cm	deg	
1	2385.81	51.45	-22.55	74.00	51.35	31.86	3.92	35.68	100	0	Peak
2	2385.81	11.99	-42.01	54.00	11.89	31.86	3.92	35.68	117	350	Average
3 X	2402.00	99.24			99.12	31.88	3.92	35.68	100	0	Peak
4 @	2402.00	84.79			84.69	31.86	3.92	35.68	117	350	Average
5	2500.00	43.10	-30.90	74.00	42.75	32.00	4.05	35.70	100	0	Peak
6	2500.00	30.98	-23.02	54.00	30.63	32.00	4.05	35.70	117	350	Average
7	4806.00	58.80	-15.20	74.00	54.59	34.12	5.77	35.68	100	0	Peak
8	4806.00	19.34	-34.66	54.00	15.13	34.12	5.77	35.68	100	187	Average
9	7362.00	54.35	-19.65	74.00	47.61	35.66	7.22	36.14	100	0	Peak
10	7362.00	14.89	-39.11	54.00	8.16	35.66	7.22	36.14	100	121	Average

Remark: #3 and #4 are Fundamental Signals.

- Test Mode : Mode 2
- Temperature : 21~26°C
- Relative Humidity : 49~57%
- Test Engineer: Sun Wang
- Polarization : Horizontal (30MHz-1GHz)

■ The test that passed at minimum margin was marked by the boldface in the following table.

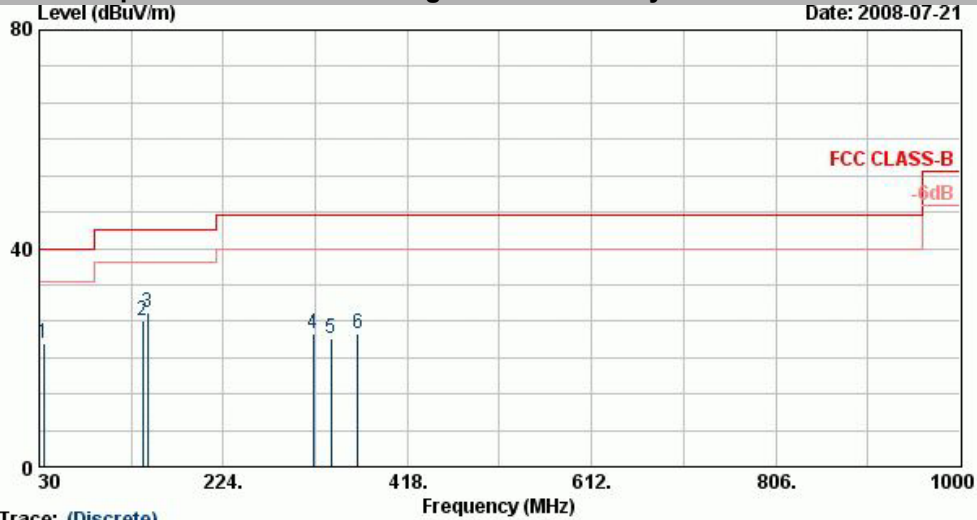

Trace: (Discrete)  
 Site : D3CH06-HY  
 Condition : FCC CLASS-B 3m LF-ANT(951121) HORIZONTAL  
 EUT : Bluetooth Speaker  
 Power : 120Vac/60Hz  
 Model : FR 643009  
 Memo : Mode 2  
 Data Rate : DHS

	Freq	Level	Over Limit	Limit Line	Read Level	Antenna Factor	Cable Loss	Preamp Factor	Ant Pos	Table Pos	Remark
	MHz	dBuV/m	dB	dBuV/m	dBuV	dB/m	dB	dB	cm	deg	
1	34.59	22.71	-17.29	40.00	38.11	16.13	0.30	31.83	---	---	Peak
2	139.08	26.82	-16.68	43.50	47.64	10.41	0.50	31.73	---	---	Peak
3	143.94	28.22	-15.28	43.50	49.09	10.30	0.54	31.71	100	229	Peak
4	318.90	24.41	-21.59	46.00	41.88	13.71	0.80	31.97	---	---	Peak
5	337.80	23.60	-22.40	46.00	40.43	14.18	0.80	31.81	---	---	Peak
6	365.80	24.43	-21.57	46.00	40.54	14.89	0.75	31.75	---	---	Peak

• Polarization : Horizontal (1GHz-25GHz)

■ The test that passed at minimum margin was marked by the boldface in the following table.

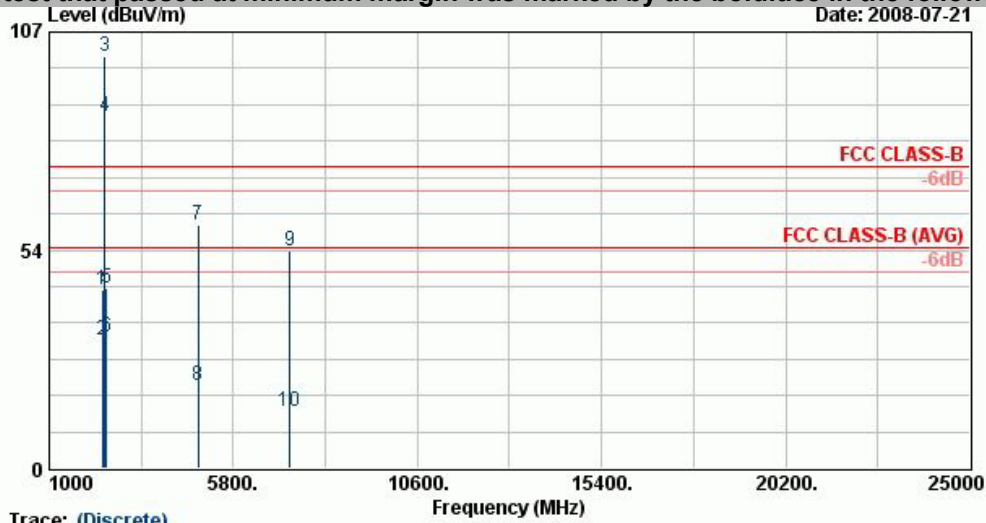

Trace: (Discrete)

Site : 03CH06-HY  
 Condition : FCC CLASS-B 3m SHF-EHF HORN HORIZONTAL  
 EUT : Bluetooth Speaker  
 Power : 120Vac/60Hz  
 Model : FR 843009  
 Memo : Mode 2  
 Data Rate : DH5

	Freq	Level	Over	Limit	Read	Antenna	Cable	Preamp	Ant	Table	Remark
	MHz	dBuV/m	Limit	Line	Level	Factor	Loss	Factor	Pos	Pos	
			dB	dBuV/m	dBuV	dB/m	dB	dB	cm	deg	
1	2388.00	43.67	-30.33	74.00	43.57	31.86	3.92	35.68	100	0	Peak
2	2388.00	31.36	-22.64	54.00	31.26	31.86	3.92	35.68	155	355	Average
3 X	2441.00	101.04			100.81	31.93	3.99	35.69	100	0	Peak
4 @	2441.00	86.36			86.14	31.93	3.99	35.69	155	355	Average
5	2486.00	44.29	-29.71	74.00	43.96	31.98	4.05	35.70	100	0	Peak
6	2486.00	32.11	-21.89	54.00	31.78	31.98	4.05	35.70	155	355	Average
7	4881.00	59.62	-14.38	74.00	55.30	34.15	5.82	35.65	100	0	Peak
8	4881.00	20.16	-33.84	54.00	15.84	34.15	5.82	35.65	100	306	Average
9	7272.00	53.49	-20.51	74.00	46.72	35.69	7.18	36.11	100	0	Peak
10	7272.00	14.03	-39.97	54.00	7.27	35.69	7.18	36.11	100	228	Average

Remark: #3 and #4 are Fundamental Signals.

- Polarization : Vertical (30MHz-1GHz)
- **■ The test that passed at minimum margin was marked by the boldface in the following table.**

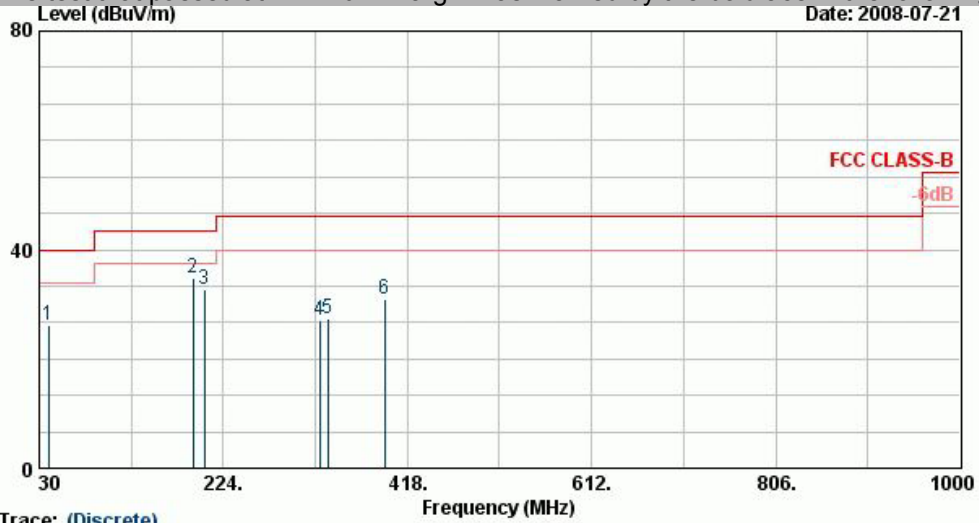

Trace: (Discrete)

Site : D3CH06-HY  
 Condition : FCC CLASS-B 3m LF-ANT(051121) VERTICAL  
 EUT : Bluetooth Speaker  
 Power : 120Vac/60Hz  
 Model : FR 843009  
 Memo : Mode 2  
 Data Rate : DHS

	Freq	Level	Over Limit	Limit Line	Read Level	Antenna Factor	Cable Loss	Preamp Factor	Ant Pos	Table Pos	Remark
	MHz	dBuV/m	dB	dBuV/m	dBuV	dB/m	dB	dB	cm	deg	
1	39.99	26.16	-13.84	40.00	44.04	13.51	0.30	31.69	---	---	Peak
2	191.73	34.67	-8.83	43.50	56.75	9.36	0.60	32.04	100	192	Peak
3	203.88	32.59	-10.91	43.50	54.61	9.53	0.60	32.15	---	---	Peak
4	325.90	27.11	-18.89	46.00	44.35	13.88	0.80	31.91	---	---	Peak
5	334.30	27.26	-18.74	46.00	44.19	14.10	0.80	31.83	---	---	Peak
6	393.80	30.86	-15.14	46.00	46.27	15.61	0.84	31.87	---	---	Peak

• Polarization : Vertical (1GHz-25GHz)

■ The test that passed at minimum margin was marked by the boldface in the following table.

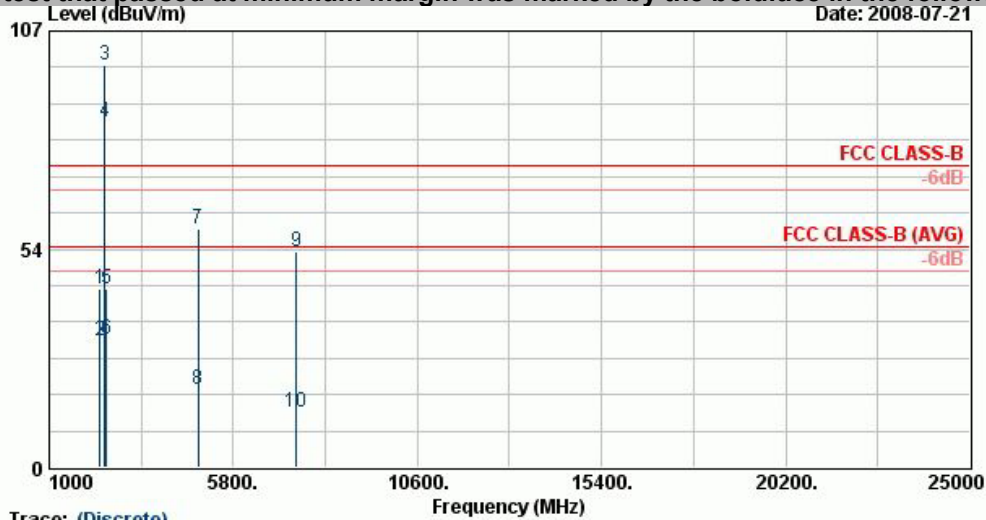

Trace: (Discrete)

Site : 03CH06-HY  
 Condition : FCC CLASS-B 3m SHF-EHF HORN VERTICAL  
 EUT : Bluetooth Speaker  
 Power : 120Vac/60Hz  
 Model : FR 843009  
 Memo : Mode 2  
 Data Rate : DHS

	Freq	Level	Over	Limit	Read	Antenna	Cable	Preamp	Ant	Table	Remark
	MHz	dBuV/m	dB	dBuV/m	dBuV	dB/m	dB	dB	cm	deg	
1	2332.00	43.64	-30.36	74.00	43.69	31.76	3.86	35.67	100	0	Peak
2	2332.00	30.90	-23.10	54.00	30.95	31.76	3.86	35.67	156	328	Average
3 X	2441.00	98.61			98.38	31.93	3.99	35.69	100	0	Peak
4 @	2441.00	84.61			84.39	31.93	3.99	35.69	156	328	Average
5	2500.00	43.81	-30.19	74.00	43.46	32.00	4.05	35.70	100	0	Peak
6	2500.00	31.24	-22.76	54.00	30.89	32.00	4.05	35.70	156	328	Average
7	4881.00	58.40	-15.60	74.00	54.08	34.15	5.82	35.65	100	0	Peak
8	4881.00	18.94	-35.06	54.00	14.62	34.15	5.82	35.65	100	154	Average
9	7437.00	52.83	-21.17	74.00	46.14	35.62	7.24	36.17	100	0	Peak
10	7437.00	13.37	-40.63	54.00	6.68	35.62	7.24	36.17	100	191	Average

Remark: #3 and #4 are Fundamental Signals.

- Test Mode : Mode 3
- Temperature : 21~26°C
- Relative Humidity : 49~57%
- Test Engineer: Sun Wang
- Polarization : Horizontal (30MHz-1GHz)

■ The test that passed at minimum margin was marked by the boldface in the following table.

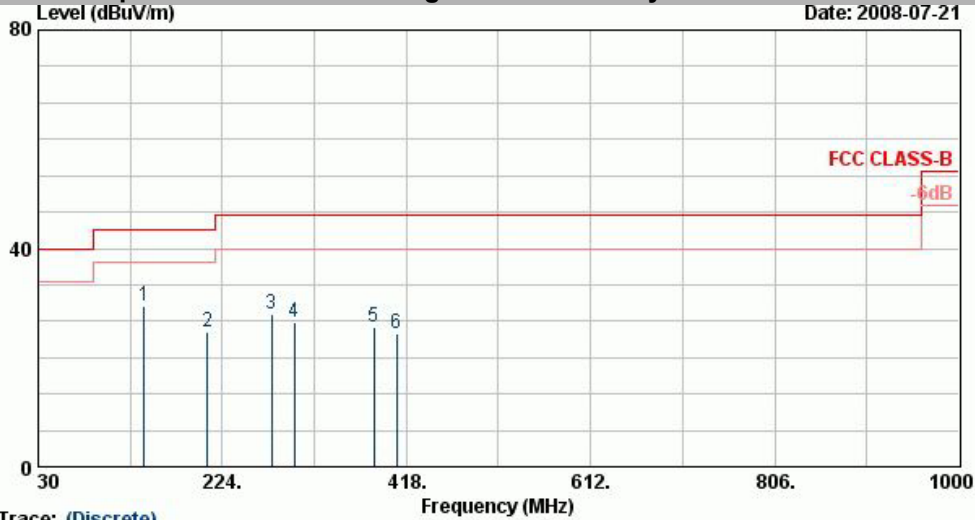

Site : D3CH06-HY  
 Condition : FCC CLASS-B 3m LF-ANT(951121) HORIZONTAL  
 EUT : Bluetooth Speaker  
 Power : 120Vac/60Hz  
 Model : FR 643009  
 Memo : Mode 3  
 Data Rate : DHS

Trace: (Discrete)

	Freq	Level	Over Limit	Limit Line	Read Level	Antenna Factor	Cable Loss	Preamp Factor	Ant Pos	Table Pos	Remark
	MHz	dBuV/m	dB	dBuV/m	dBuV	dB/m	dB	dB	cm	deg	
1	141.78	29.57	-13.93	43.50	50.49	10.28	0.52	31.72	1000	107	Peak
2	207.93	24.67	-18.83	43.50	46.51	9.76	0.60	32.19	---	---	Peak
3	276.24	27.92	-18.08	46.00	46.44	12.77	0.70	31.98	---	---	Peak
4	300.00	26.39	-19.61	46.00	44.63	13.21	0.70	32.15	---	---	Peak
5	383.30	25.52	-20.48	46.00	41.14	15.34	0.87	31.82	---	---	Peak
6	407.80	24.24	-21.76	46.00	39.36	15.89	0.90	31.91	---	---	Peak

• Polarization : Horizontal (1GHz-25GHz)

■ The test that passed at minimum margin was marked by the boldface in the following table.

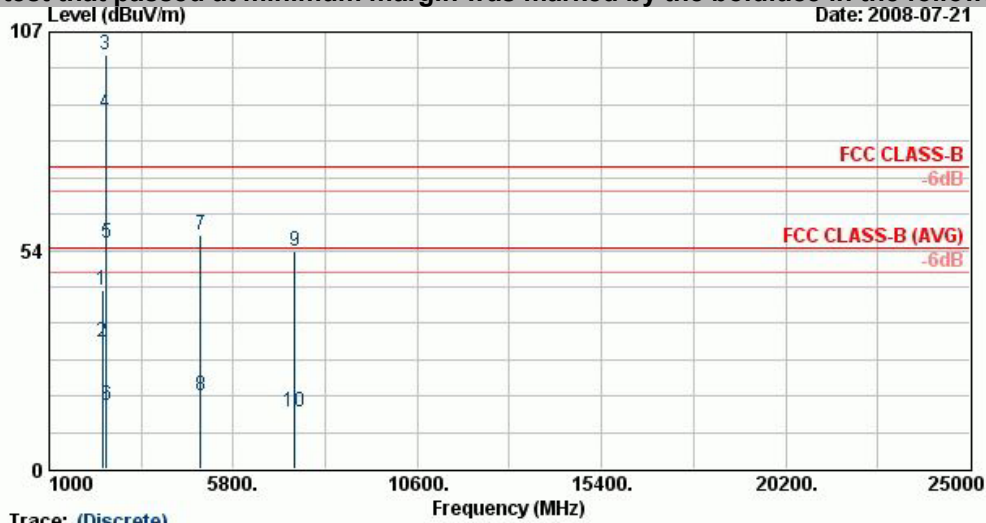

Trace: (Discrete)  
 Site : 03CH06-HY  
 Condition : FCC CLASS-B 3m SHF-EHF HORN HORIZONTAL  
 EUT : Bluetooth Speaker  
 Power : 120Vac/60Hz  
 Model : FR 843009  
 Memo : Mode 3  
 Data Rate : DR5

	Freq	Level	Over	Limit	Read	Antenna	Cable	Preamp	Ant	Table	Remark
	MHz	dBuV/m	Limit	Line	Level	Factor	Loss	Factor	Pos	Pos	
			dB	dBuV/m	dBuV	dB/m	dB	dB	cm	deg	
1	2390.00	43.87	-30.13	74.00	43.77	31.86	3.92	35.68	100	0	Peak
2	2390.00	31.17	-22.83	54.00	31.07	31.86	3.92	35.68	149	358	Average
3 X	2480.00	101.47			101.14	31.98	4.05	35.70	100	0	Peak
4 @	2480.00	87.11			86.78	31.98	4.05	35.70	149	358	Average
5	2483.50	55.16	-18.84	74.00	54.83	31.98	4.05	35.70	100	0	Peak
6	2483.50	15.70	-38.30	54.00	15.37	31.98	4.05	35.70	149	358	Average
7	4956.00	57.41	-16.59	74.00	52.98	34.19	5.87	35.62	100	0	Peak
8	4956.00	17.95	-36.05	54.00	13.52	34.19	5.87	35.62	100	314	Average
9	7401.00	53.22	-20.78	74.00	46.51	35.63	7.24	36.16	100	0	Peak
10	7401.00	13.76	-40.24	54.00	7.05	35.63	7.24	36.16	100	245	Average

Remark: #3 and #4 are Fundamental Signals.



• Polarization : Vertical (30MHz-1GHz)

■ The test that passed at minimum margin was marked by the boldface in the following table.

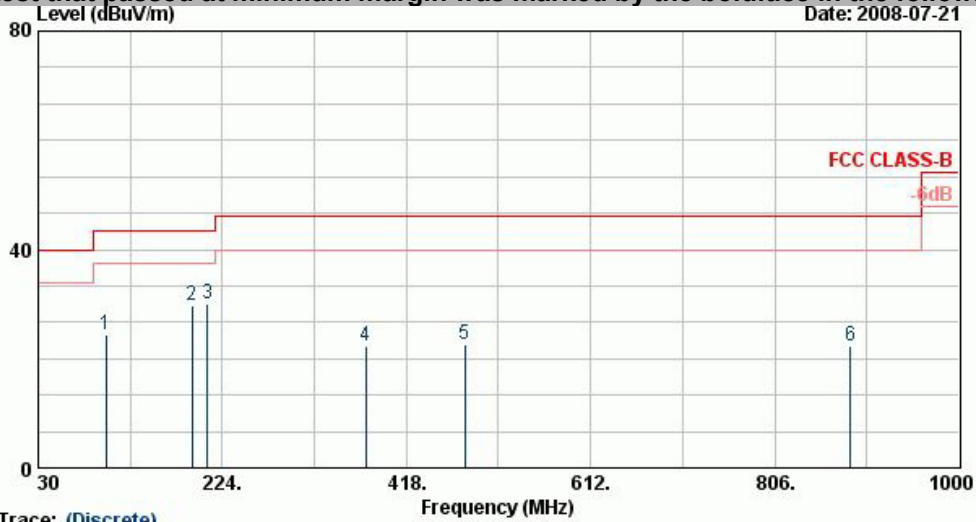

Trace: (Discrete)

Site : 03CH06-HY  
 Condition : FCC CLASS-B 3m LF-ANT(951121) VERTICAL  
 EUT : Bluetooth Speaker  
 Power : 120Vac/60Hz  
 Model : FR 843009  
 Memo : Mode 3  
 Data Rate : DHS

	Freq	Level	Over Limit	Limit Line	ReadAntenna	Cable	Preamp	Ant	Table	Remark
	MHz	dBuV/m	dB	dBuV/m	dBuV	dB	dB	cm	deg	
1	101.28	24.35	-19.15	43.50	44.81	11.07	0.50	32.02	---	Peak
2	191.73	29.74	-13.76	43.50	51.82	9.36	0.60	32.04	---	Peak
<b>3</b>	<b>207.93</b>	<b>30.04</b>	<b>-13.46</b>	<b>43.50</b>	<b>51.88</b>	<b>9.76</b>	<b>0.60</b>	<b>32.19</b>	<b>100</b>	<b>171</b> Peak
4	374.90	22.44	-23.56	46.00	38.24	15.14	0.85	31.79	---	Peak
5	479.90	22.67	-23.33	46.00	36.64	17.09	1.00	32.06	---	Peak
6	885.90	22.16	-23.84	46.00	32.31	20.43	1.30	31.88	---	Peak

• Polarization : Vertical (1GHz-25GHz)

■ The test that passed at minimum margin was marked by the boldface in the following table.

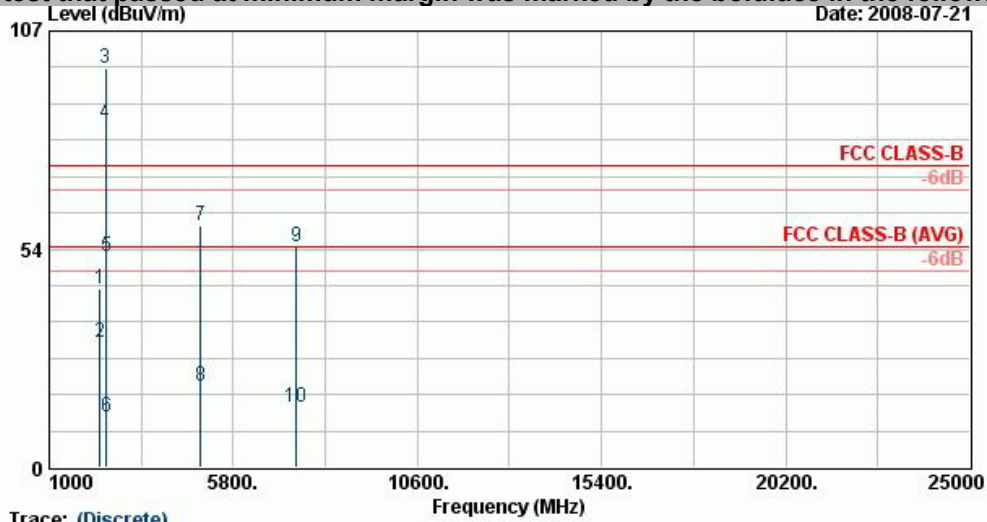

Trace: (Discrete)

Site : D3CH06-HY  
 Condition : FCC CLASS-B 3m SHF-EHF HORN VERTICAL  
 EUT : Bluetooth Speaker  
 Power : 120Vac/60Hz  
 Model : FR 843009  
 Memo : Mode 3  
 Data Rate : DHS

	Freq	Level	Over	Limit	Read	Antenna	Cable	Preamp	Ant	Table	Remark
	MHz	dBuV/m	Limit	Line	Level	Factor	Loss	Factor	Pos	Pos	
			dB	dBuV/m	dBuV	dB/m	dB	dB	cm	deg	
1	2318.00	43.58	-30.42	74.00	43.66	31.76	3.82	35.67	100	0	Peak
2	2318.00	30.83	-23.17	54.00	30.91	31.76	3.82	35.67	154	330	Average
3 X	2480.00	98.00			97.67	31.98	4.05	35.70	100	0	Peak
4 @	2480.00	84.21			83.88	31.98	4.05	35.70	154	330	Average
5	2483.50	51.69	-22.31	74.00	51.36	31.98	4.05	35.70	100	0	Peak
6	2483.50	12.23	-41.77	54.00	11.90	31.98	4.05	35.70	154	330	Average
7	4956.00	59.26	-14.74	74.00	54.83	34.19	5.87	35.62	100	0	Peak
8	4956.00	19.80	-34.20	54.00	15.37	34.19	5.87	35.62	100	218	Average
9	7437.00	54.11	-19.89	74.00	47.42	35.62	7.24	36.17	100	0	Peak
10	7437.00	14.65	-39.35	54.00	7.96	35.62	7.24	36.17	100	124	Average

Remark: #3 and #4 are Fundamental Signals.

## 5.10 Antenna Requirements

### 5.10.1 Standard Applicable

For intentional device, according to FCC 47 CFR Section 15.203, an intentional radiator shall be designed to ensure that no other antenna except assembled by the responsible party shall be used with the device.

And according to FCC 47 CFR Section 15.247 (b), if directional gain of transmitting antennas is greater than 6dBi, the power shall be reduced by the same level in dB comparing to gain minus 6dBi.

### 5.10.2 Antenna Connected Construction

The antenna used in this product is Chip Antenna for Bluetooth without connector and it is considered to meet antenna requirement of FCC.

### 5.10.3 Antenna Gain

The antenna gain of EUT is less than 6dBi. Therefore, it is not necessary to reduce maximum peak output power limit.

## 6 List of Measuring Equipments

Instrument	Manufacturer	Model No.	Serial No.	Characteristics	Calibration Date	Due Date	Remark
EMC Receiver	R&S	ESCS 30	100359	9kHz – 2.75GHz	Mar. 03, 2008	Mar. 02, 2009	Conduction (CO04-HY)
LISN	MessTec	NNB-2/16Z	99079	9kHz – 30MHz	Mar. 31, 2008	Mar. 29, 2009	Conduction (CO04-HY)
LISN (Support Unit)	EMCO	3810/2NM	9703-1839	9kHz – 30MHz	Mar. 22, 2008	Mar. 21, 2009	Conduction (CO04-HY)
RF Cable-CON	UTIFLEX	3102-26886-4	CB049	9kHz – 30MHz	Apr. 20, 2008	Apr. 19, 2009	Conduction (CO04-HY)
ISN	SCHAFFNER	ISN T400	21653	9kHz –30MHz	Mar. 27, 2008	Mar. 26, 2009	Conduction (CO04-HY)
Spectrum Analyzer	Agilent	E4408B	MY44211030	9KHz~26.5GHz	Oct. 24, 2008	Oct. 23, 2009	Radiation (03CH06-HY)
Spectrum Analyzer	R&S	FSP40	100057	9KHz~40GHz	Oct. 16, 2008	Oct. 15, 2009	Radiation (03CH06-HY)
EMI Test Receiver	R&S	ESVS10	834468/003	20MHz~1000MHz	Apr. 24, 2008	Apr. 23, 2009	Radiation (03CH06-HY)
Bilog Antenna	SCHAFFNER	CBL6112B	2885	30MHz -2GHz	Nov. 12, 2008	Nov. 11, 2009	Radiation (03CH06-HY)
Double Ridge Horn Antenna	EMCO	3117	00066583	1G~18GHz	Aug. 18, 2008	Aug. 17, 2009	Radiation (03CH06-HY)
Double Ridge Horn Antenna	Training Research	AF-0801	95119	8G~18G	Oct. 28, 2008	Oct. 27, 2009	Radiation (03CH06-HY)
SHF-EHF Horn	SCHWARZBECK	BBHA 9170	9170-251	14G~40GHz	Oct. 16, 2008	Oct. 15, 2009	Radiation (03CH06-HY)
Pre Amplifier	Agilent	8449B	3008A01917	1G - 26.5GHz	Nov. 11, 2008	Nov. 10, 2009	Radiation (03CH06-HY)
Pre Amplifier	Agilent	310N	186713	9KHz~1GHz	Apr. 21, 2008	Apr. 20, 2009	Radiation (03CH06-HY)

## 7 Uncertainty Evaluation

### Uncertainty of Conducted Emission Measurement (150 KHz ~ 30 MHz)

Contribution	Uncertainty of $x_i$		$u(x_i)$
	dB	Probability Distribution	
Receiver reading	0.10	Normal(k=2)	0.05
Cable loss	0.10	Normal(k=2)	0.05
AMN insertion loss	2.50	Rectangular	0.63
Receiver Spec	1.50	Rectangular	0.43
Site imperfection	1.39	Rectangular	0.80
Mismatch	+0.34/-0.35	U-shape	0.24
<b>Combined standard uncertainty Uc(y)</b>	<b>1.13</b>		
<b>Measuring uncertainty for a level of confidence of 95% U=2Uc(y)</b>	<b>2.26</b>		

### Uncertainty of Radiated Emission Measurement (30 MHz ~ 1000 MHz)

Contribution	Uncertainty of $x_i$		$u(x_i)$
	dB	Probability Distribution	
Receiver reading	0.11	Normal(k=2)	0.06
Antenna factor calibration	0.91	Normal(k=2)	0.46
Cable loss calibration	0.12	Normal(k=2)	0.06
Pre Amplifier Gain calibration	0.15	Normal(k=2)	0.08
RCV/SPA specification	2.50	Rectangular	0.72
Antenna Factor Interpolation for Frequency	1.00	Rectangular	0.29
Site imperfection	1.52	Rectangular	0.88
Mismatch	+0.45/-0.48	U-shaped	0.33
<b>Combined standard uncertainty Uc(y)</b>	<b>1.30</b>		
<b>Measuring uncertainty for a level of confidence of 95% U=2Uc(y)</b>	<b>2.60</b>		

**Uncertainty of Radiated Emission Measurement (1 GHz ~ 40 GHz)**

Contribution	Uncertainty of $x_i$		$u(x_i)$	$C_i$	$C_i * u(x_i)$
	dB	Probability Distribution			
Receiver reading	±0.10	Normal(k=1)	0.10	1	0.10
Antenna factor calibration	±1.70	Normal(k=2)	0.85	1	0.85
Cable loss calibration	±0.50	Normal(k=2)	0.25	1	0.25
Receiver Correction	±2.00	Rectangular	1.15	1	1.15
Antenna Factor Directional	±1.50	Rectangular	0.87	1	0.87
Site imperfection	±2.80	Triangular	1.14	1	1.14
Mismatch Receiver VSWR $\Gamma_1 = 0.197$ Antenna VSWR $\Gamma_2 = 0.194$ Uncertainty = $20 \log(1 - \Gamma_1 * \Gamma_2)$	+0.34/-0.35	U-shaped	0.244	1	0.244
<b>Combined standard uncertainty <math>U_c(y)</math></b>	<b>2.36</b>				
<b>Measuring uncertainty for a level of confidence of 95% <math>U = 2U_c(y)</math></b>	<b>4.72</b>				

The measured result is :  $y$  dBuV  $\pm$   $U$  dB  
for a level of confidence of approximately 95% , (  $k = 2$  )



## Appendix A. Photographs of EUT

Please refer to Sporton report number EP843009 as below.