

77 GHz CRN Radar Sensor

User Manual

Product Model: 77V13CRN

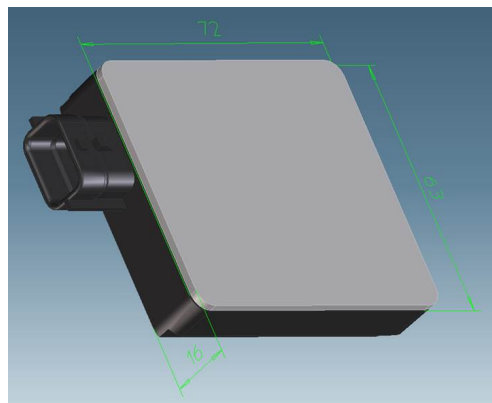

Veoneer US, Inc.

26360 American Drive
Southfield, Michigan 48034 USA
Phone: +1 248 223 0600
Fax: +1 248 223 8833

Table of Contents

1	<u>ABBREVIATIONS</u>	3
1.1	LIST OF TERMINOLOGY AND ACRONYMS	3
2	<u>PRODUCT OVERVIEW</u>	3
2.1	PRODUCT DESCRIPTION	3
2.2	PRODUCT APPLICATION EXAMPLES	3
3	<u>TYPICAL INSTALLATION</u>	4
4	<u>HARDWARE DESCRIPTION</u>	4
5	<u>SENSOR VARIANTS</u>	5
5.1	GENERIC SPECIFICATIONS	5
6	<u>SENSOR FEATURES</u>	6
7	<u>CONFORMANCE STATEMENTS</u>	6
7.1	USA	6
7.2	CANADA	7
7.3	EUROPE	7
8	<u>REVISION HISTORY</u>	7

Table of Figures

FIGURE 1: TYPICAL INSTALLATION POSITIONS	4
FIGURE 2: GENERIC SENSOR	4

1 Abbreviations

1.1 List of Terminology and Acronyms

BSM	Blind Spot Monitoring
BSW	Blind Spot Warning
PCB	Printed Circuit Board
CAN	Controller Area Network
CAN FD	Controller Area Network Flexible Data-rate
ECU	Electronic Control Unit (CAN bus Master located in the automobile)
GHz	Giga-Hertz (10 ⁹)
HP	Host Processor
LCA	Lane Change Assist
PCB	Printed Circuit Board
PWM	Pulse Width Modulation
RADAR	RAdio Detection And Ranging
RCTA	Rear Cross Traffic Alert
RF	Radio Frequency (or Microwave)
LED	Light Emitting Diode
CTA/B	Collision Traffic Alert/Break
EIRP	Equivalent Isotropically Radiated Power
ADAS	Advanced Driver Assistance Systems

2 Product Overview

2.1 Product Description

The products described here are part of a family of radars offered by Veoneer. They are intended for automotive use, operating in the 76-77 GHz band.

The radars are integrated into a vehicle to enhance vehicle safety systems. They can be integrated as a standalone sensor or sensors, or as part of more complex system that also may include cameras, lidar, and other type of sensors to provide features like Blind Spot Warning (BSW), Lane Change Assist (LCA), Collision Traffic Alert/Break (CTA/B) and other Autonomous Driving functions.

2.2 Product Application Examples

The product can be used, but is not limited to the following applications:

- Autonomous drive systems
- Automatic braking systems
- Lane change warning
- Adaptive cruise control
- Collision prevention systems
- Automatic lane change systems
- Pedestrian and Bicycle collision prevention
- Etc.

3 Typical Installation

The radar is typically installed in the positions of the vehicle depicted in Figure 1 often mounted behind a bumper or emblem.

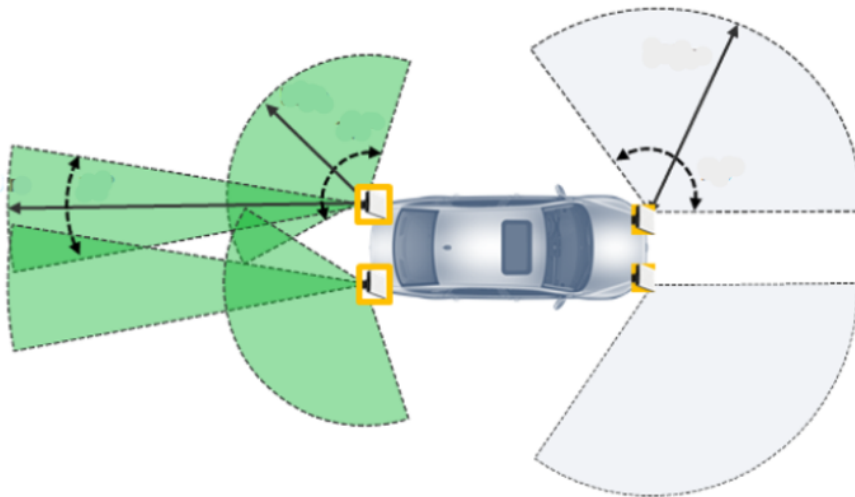

Figure 1: Typical Installation Positions

4 Hardware Description

The radar assembly consists of 1 PCB board, with the antennas, all the RF components, the analog to digital converters, the main processor, as well as components for communications with the vehicle and power management. The PCB is contained in a sealed housing.

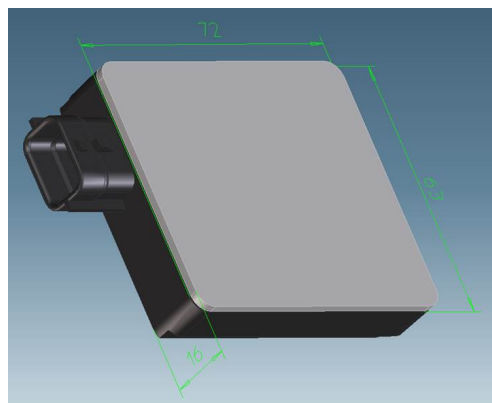

Figure 2: Generic Sensor

5 Sensor Variants

5.1 Generic Specifications

Sensor Specifications & Functions	Value	Unit
Operating Conditions		
Frequency Band	76-77	GHz
Power Dissipation	5.5	W
Vehicle Network Interface	CAN/CAN-FD	
Operating Temperature	-40 to +85	C
Input Operating Voltage	8 – 16	V
Operating Life	15 years	
Waveform Parameters		
Cycle Time	50	ms
Bandwidth	925	MHz
Center Frequency	76.5	GHz
Physical Parameters		
Size	72x63x16	mm
Weight	<120	g
Vehicle Physical Interface	2x4 Yazaki or 1x8 USCAR connector	

Variants of the 77V13CRN:

681083100B
 681284500B
 681284400B
 680907900A

6 Sensor Features

- **Blind Spot Monitoring (BSM)** - The BSM algorithm detects and reports "Objects of Interest" on either side of the vehicle, within a specified "blind spot" zone. The feature generates a signal based on which a LED display is driven. The LED is usually placed in the outside view mirror to alert the driver to the presence of objects of interest within the defined zone. The sensor can also output a signal on the CAN if necessary.
- **Lane Change Warning/Assist (LCW/A)** - The LCW/A algorithm detects and reports to the driver that a highway licensable vehicle is rapidly approaching the host vehicle in one of the adjacent lanes. The feature generates a signal which is used to drive a visual display placed in the outside view mirror and/or request a chime or vibrating seat cushion, to alert the driver to the approach of objects of interest within the defined LCA zone. The signal can also be used by the ADAS system to engage/dis-engage lane change.

Rear Cross Traffic Alert/Break (RCTA/B) - The RCTA/B algorithm detects and reports "Objects of Interest" behind the host vehicle, within a specified RCTA/B coverage zone when going backward. The feature generates a signal which is used to drive a visual display to alert the driver of the presence of objects of interest that may cause a collision with the host vehicle within the defined RCTA zone. The signal can also be used to control the break.

7 Conformance Statements

7.1 Note

This equipment should be operated at a minimum distance of 20 cm from the user.

This equipment complies with FCC and IC radiation exposure limits set forth for an uncontrolled environment.

This equipment should be installed and operated with minimum distance of 20 cm between the radiator and your body.

This transmitter must not be co-located or operating in conjunction with any other antenna or transmitter.

Cet équipement est conforme aux limites d'exposition aux rayonnements IC établies pour un environnement non contrôlé.

Cet équipement doit être installé et utilisé avec un minimum de 20 cm de distance entre la source de rayonnement et votre corps.

Ce transmetteur ne doit pas être placé au même endroit ou utilisé simultanément avec un autre transmetteur ou antenne.

7.2 USA

This device complies with Part 15 of the FCC Rules. Operation is subject to the following two conditions: (1) this device may not cause harmful interference, and (2) this device must accept any interference received, including interference that may cause undesired operation. CAUTION TO USERS Changes or modifications not expressly approved by the party responsible for compliance could void the user's authority to operate the equipment.

Additionally, it should be mentioned, that the integrator is advised to have this statement in their user manual as well.

7.3 Canada

This device contains license-exempt transmitter(s)/receiver(s) that comply with Innovation, Science and Economic Development Canada’s license-exempt RSS(s). Operation is subject to the following two conditions: (1) This device may not cause interference. (2) This device must accept any interference, including interference that may cause undesired operation of the device.

L’émetteur/récepteur exempt de licence contenu dans le présent appareil est conforme aux CNR d’Innovation, Sciences et Développement économique Canada applicables aux appareils radio exempts de licence. L’exploitation est autorisée aux deux conditions suivantes : 1) L’appareil ne doit pas produire de brouillage; 2) L’appareil doit accepter tout brouillage radioélectrique subi, même si le brouillage est susceptible d’en compromettre le fonctionnement.

7.4 Europe

Hereby, Veoneer US, Inc declares that the radio equipment type 77V13CRN is in compliance with Directive 2014/53/EU.

Operational frequency band: 76 – 77GHz

Maximum radio-frequency output power: < 55 dBm peak eirp

The full text of the EU declaration of conformity is available at the following internet address:
<https://www.veoneer.com/en/regulatory>

8 Revision History

The revision number in table below is the PLM revision and version number. The Description/Comment is the same description that is found in PLM in check comment.

Revision	Date	Author(s)	Description/comment
000 v1	2020-05-27	Shobana R	Draft
000 v2	2020-06-15	Shobana R	Updated based on review comments