

Partial Test Report

Test report no.: 24040060-40452-1

Date of issue: 2024-06-25

Test result: The test item - **passed** - and complies with below listed standards.

Applicant

Magna Electronics, LLC

Manufacturer

Magna Electronics, LLC

Test Item

77V12FLR

RF-Spectrum Testing according to:

FCC 47 CFR Part 95
Personal radio services,
Subpart M - The 76-81 GHz Band Radar Service

Tested by
(name, function, signature)

Sebastian Janoschka
Head of Dept RF



signature

Approved by
(name, function, signature)

Karsten Gerald
Lab manager RF



signature

Applicant and Test item details	
Applicant	Magna Electronics, LLC 26360 American Drive MI 48034, Southfield, USA
Manufacturer	Magna Electronics, LLC 26360 American Drive MI 48034, Southfield, USA
Test item description	77 GHz FL Radar Sensor
Model/Type reference	77V12FLR
Standard specific information	
FCC ID	WU877V12FLR
Technology	Radar Sensor
Frequency	76 GHz to 77 GHz
Antenna	integrated patch antenna
Power supply	8.0 to 17.0 V DC
Temperature range	-40 °C to +85 °C

Disclaimer and Notes

The content of this report relates to the mentioned test sample(s) only.
IBL-Lab GmbH does not take samples. The samples used for testing are provided by the applicant.
Without a written permit of IBL-Lab GmbH, this test report shall not be reproduced, except in full.

The last valid version is available at [TAMSys®](#).

Signatures are done electronically, if signer does not match stated signer, it is signed per order.
Information supplied by the applicant can affect the validity of results. The data is marked accordingly.

Copyright ©: All rights reserved by IBL-Lab GmbH

Within this test report, a point / comma is used as a decimal separator.
If otherwise, a detailed note is added adjected to its use.

Decision rule:

Decision rule based on simple acceptance without guard bands, binary statement, based on mutually agreed uncertainty tolerances with expansion factor k=2.

1 TABLE OF CONTENTS

1	TABLE OF CONTENTS	3
2	GENERAL INFORMATION	4
2.1	Administrative details	4
2.2	Possible test case verdicts	5
2.3	Observations	5
2.4	Opinions and interpretations	5
2.5	Revision History	5
2.6	Further documents	5
3	ENVIRONMENTAL & TEST CONDITIONS	6
3.1	Environmental conditions	6
3.2	Normal and extreme test conditions	6
4	TEST STANDARDS AND REFERENCES	6
5	EQUIPMENT UNDER TEST (EUT)	7
5.1	Product description	7
5.2	Description of test item	7
5.3	Technical data of test item	7
5.4	Additional information	7
6	SUMMARY OF TEST RESULTS	8
7	TEST RESULTS	9
7.1	RF power output (§2.1046 & §95.3367)	9
7.2	Occupied bandwidth (§2.1049)	12
7.3	Field strength of spurious radiation (§2.1053 & §95.3379)	13
8	Test Setup Description	18
8.1	Semi Anechoic Chamber with Ground Plane	19
8.2	Fully Anechoic Chamber	21
8.3	Radiated measurements > 18 GHz	22
8.4	Radiated measurements > 50 GHz	22
8.5	Frequency error	24
9	Measurement procedures	25
9.1	Radiated spurious emissions from 9 kHz to 30 MHz	25
9.2	Radiated spurious emissions from 30 MHz to 1 GHz	26
9.3	Radiated spurious emissions from 1 GHz to 18 GHz	27
9.4	Radiated spurious emissions above 18 GHz	28
10	MEASUREMENT UNCERTAINTIES	29
Annex 1	EUT Photographs, external	30
Annex 2	EUT Photographs, internal	33
Annex 3	Test Setup Photographs	37

2 GENERAL INFORMATION

2.1 Administrative details

Testing laboratory	IBL-Lab GmbH Heinrich-Hertz-Allee 7 66386 St. Ingbert / Germany Fon: +49 6894 38938-0 Fax: +49 6894 38938-99 URL: https://ib-lenhardt.com/ E-Mail: info@ib-lenhardt.com
Accreditation / Designation	<p>The testing laboratory is accredited by Deutsche Akkreditierungsstelle GmbH (DAkKS) in compliance with DIN EN ISO/IEC 17025:2018.</p> <p>Scope of testing and registration number:</p> <ul style="list-style-type: none"> • Attachment to the accreditation certificate D-PL-21375-01-00 <ul style="list-style-type: none"> ○ Electronics ○ Electromagnetic Compatibility ○ Radio ○ Electromagnetic Compatibility and Telecommunication (FCC requirements) ○ Telecommunication (TC) and Electromagnetic Compatibility (EMC) for Canadian Standards ○ Automotive EMC <p>Website DAkKS: https://www.dakks.de/ The Deutsche Akkreditierungsstelle GmbH (DAkKS) is also a signatory to the ILAC Mutual Recognition Arrangement.</p> <ul style="list-style-type: none"> • Designations <ul style="list-style-type: none"> ○ FCC Testing Laboratory Designation Number DE0024 ○ ISED ISED Company Number 27156 Testing Laboratory CAB Identifier DE0020 ○ Krafftahrt-Bundesamt KBA-P 00120-23
Testing laboratory	IBL-Lab GmbH Heinrich-Hertz-Allee 7 66386 St. Ingbert / Germany Fon: +49 6894 38938-0 Fax: +49 6894 38938-99 URL: https://ib-lenhardt.com/ E-Mail: info@ib-lenhardt.com
Date of receipt of test samples	2024-05-02
Start – End of tests	2024-05-02 – 2024-05-03

2.2 Possible test case verdicts

Test sample meets the requirements	P (PASS)
Test sample does not meet the requirements	F (FAIL)
Test case does not apply to the test sample	N/A (Not applicable)
Test case not performed	N/P (Not performed)

2.3 Observations

No additional observations other than the reported observations within this test report have been made.

2.4 Opinions and interpretations

No appropriate opinions or interpretations according ISO/IEC 17025:2017 clause 7.8.7 are within this test report.

2.5 Revision History

-0 Initial Version

-1 Revision: operational frequency band corrected

This test report 24040060-40452-1 replaces the previous test report 24040060-40452-0.

<Ende Revisionsbeschreibungen>

2.6 Further documents

List of further applicable documents belonging to the present test report:

– no additional documents –

3 ENVIRONMENTAL & TEST CONDITIONS

3.1 Environmental conditions

Temperature	20°C ± 5°C
Relative humidity	25-75% r.H.
Barometric Pressure	860-1060 mbar
Power supply	230 V AC ± 5%

3.2 Normal and extreme test conditions

	minimum	normal	maximum
Temperature	-40 °C	+23 °C	+85 °C
Relative humidity	-/-	45 % r.h.	-/-
Power supply	8 V DC	13.4 V DC	17 V DC

4 TEST STANDARDS AND REFERENCES

Test standard (accredited)	Description
FCC 47 CFR Part 95	Personal radio services, Subpart M - The 76-81 GHz Band Radar Service

Reference	Description
ANSI C63.4-2014	American National Standard for Methods of Measurement of Radio-Noise Emissions from Low-Voltage Electrical and Electronic Equipment in the Range of 9 kHz to 40 GHz
ANSI C63.10-2013	American National Standard of Procedures for Compliance Testing of Unlicensed Wireless Devices
ANSI C63.26-2015	American National Standard for Compliance Testing of Transmitters Used in Licensed Radio Services
KDB 653005 D01, V01, R02	Equipment Authorization Guidance for 76-81 GHz Radar Devices

5 EQUIPMENT UNDER TEST (EUT)

5.1 Product description

77 GHz FL Radar Sensor

5.2 Description of test item

Model name*	77V12FLR
Serial number*	00007
PCB identifier*	PCBA DSP - 682826200A PCBA RF - 680352700C
Hardware status*	AE1/V216
Software status*	R255_31_14D28_1

*: as declared by applicant

5.3 Technical data of test item

Operational frequency band*	76 GHz to 77 GHz
Type of radio transmission*	modulated carrier
Modulation type*	FMCW
Number of channels*	1
Channel bandwidth*	< 1 GHz
Channel spacing*	N/A
Receiver category*	N/A
Receiver bandwidth*	N/A
Duty cycle*	~38 %
Antenna*	integrated patch antenna
Power supply*	8.0 to 17.0 V DC
Temperature range*	-40 °C to +85 °C

*: as declared by applicant

5.4 Additional information

Model differences	none
Additional application considerations to test a component or sub-assembly	none
Ancillaries tested with	none

6 SUMMARY OF TEST RESULTS

Test specification

FCC 47 CFR Part 95 Subpart M

Clause	Requirement / Test case	Test Conditions	Result / Remark	Verdict
§2.1046 §95.3367 (a) (b)	RF power output	Nominal		P
§2.1047	Modulation characteristics	Nominal		N/P
§2.1049	Occupied bandwidth	Nominal		N/P
§2.1051	Spurious emissions at antenna terminals	Nominal	see note	N/P
§2.1053 §95.3379 (a)(1) §95.3379 (a)(2) §95.3379 (a)(3)	Field strength of spurious radiation	Nominal		P
§2.1055 §95.3379 (b)	Frequency stability	Nominal Extreme		N/P

Notes

FCC's Millimeter Wave Test Procedures:

I. A radiated method of measurements in order to demonstrate compliance with the various regulatory requirements has been chosen in consideration of test equipment availability and the limitations of many external harmonic mixers. A conducted method of measurement could be employed if EUT and mixer waveguides both are accessible and of the same type (WG number) and if waveguide sections and transitions can be found. Another potential problem is that the peak power output may exceed the +20 dBm input power limit of many commercially available mixers. For these reasons a radiated method is preferred.

Comments and observations

– none –

7 TEST RESULTS

7.1 RF power output (§2.1046 & §95.3367)

Description

§2.1046 Measurements required: RF power output.

(a) For transmitters other than single sideband, independent sideband and controlled carrier radiotelephone, power output shall be measured at the RF output terminals when the transmitter is adjusted in accordance with the tune-up procedure to give the values of current and voltage on the circuit elements specified in §2.1033(c)(8). The electrical characteristics of the radio frequency load attached to the output terminals when this test is made shall be stated.

Limits

The fundamental radiated emission limits within the 76-81 GHz band are expressed in terms of Equivalent Isotropically Radiated Power (EIRP) and are as follows:

- (a) The maximum power (EIRP) within the 76-81 GHz band shall not exceed 50 dBm based on measurements employing a power averaging detector with a 1 MHz Resolution Bandwidth (RBW).
- (b) The maximum peak power (EIRP) within the 76-81 GHz band shall not exceed 55 dBm based on measurements employing a peak detector with a 1 MHz RBW.

Test procedure

Mean Power

Method with spectrum analyser

A spectrum analyser with the following settings is used as measuring receiver in the test set-up:

- Start frequency: lower than the lower edge of the operating frequency range.
- Stop frequency: higher than the upper edge of the operating frequency range.
- Resolution bandwidth: 1 MHz.
- Video bandwidth: 3 MHz.
- Detector mode: RMS.
- Display mode: clear write.
- Averaging time: larger than one EUT cycle time.
- Sweep time: averaging time × number of sweep points.

Channel Power function needs to be used to calculate the average power. Boundaries for the calculation needs to be defined. This is typically the operating frequency range.

Method with power meter

The power meter shall be connected to the measurement antenna. The frequency correction factor shall be taken into account. The power meter shall be a true RMS power meter. The measurement time shall be equal or longer than the EUT cycle time.

Test procedure

Peak Power

Method with a spectrum analyser

A spectrum analyser with the following settings is used as measuring receiver in the test set-up:

- Start frequency: lower than the lower edge of the operating frequency range.
- Stop frequency: higher than the upper edge of the operating frequency range.
- Resolution bandwidth: 1 MHz.
- Video bandwidth: 3 MHz.
- Detector mode: Peak detector.
- Display mode: Maxhold.
- Averaging time: larger than one EUT cycle time.
- Sweep time: averaging time × number of sweep points.

The peak power to be considered is the maximum value recorded.

Test setup: 8.3			
Test results:			
EUT mode	Test distance	Radiated Mean Power (EIRP) [dBm]	Radiated Peak Power (EIRP) [dBm]
Normal operating	1.5 m	22.27	30.13

Plot no. 1: Mean Power EIRP, RMS detector / Channel Power

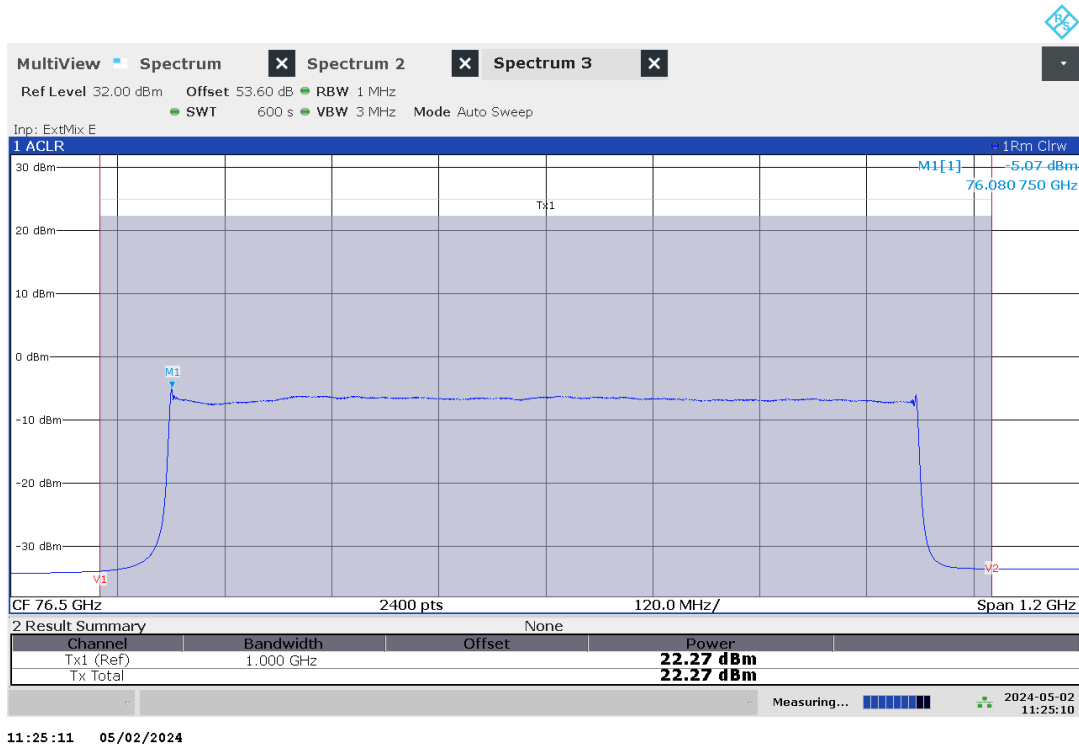

Plot no. 2: Peak Power EIRP, Peak detector



Plot no. 3: Peak Power EIRP, Peak detector, 10 MHz RBW due to pulse desensitisation.



7.2 Occupied bandwidth (§2.1049)

Description

§2.1049 Measurements required: Occupied bandwidth.

The occupied bandwidth, that is the frequency bandwidth such that, below its lower and above its upper frequency limits, the mean powers radiated are each equal to 0.5 percent of the total mean power radiated by a given emission shall be measured.

Limits

The radar device's occupied bandwidth (i.e. 99% emission bandwidth) shall be contained in the 76-81GHz frequency band.

Test procedure

ANSI C63.10, 6.9.3

The occupied bandwidth is the frequency bandwidth such that, below its lower and above its upper frequency limits, the mean powers are each equal to 0.5% of the total mean power of the given emission.

The following procedure shall be used for measuring 99% power bandwidth:

- a) The instrument center frequency is set to the nominal EUT channel center frequency. The frequency span for the spectrum analyzer shall be between 1.5 times and 5.0 times the OBW.
- b) The nominal IF filter bandwidth (3 dB RBW) shall be in the range of 1% to 5% of the OBW, and VBW shall be approximately three times the RBW, unless otherwise specified by the applicable requirement.
- c) Set the reference level of the instrument as required, keeping the signal from exceeding the maximum input mixer level for linear operation. In general, the peak of the spectral envelope shall be more than $[10 \log(\text{OBW}/\text{RBW})]$ below the reference level. Specific guidance is given in 4.1.5.2.
- d) Step a) through step c) might require iteration to adjust within the specified range.
- e) Video averaging is not permitted. Where practical, a sample detection and single sweep mode shall be used. Otherwise, peak detection and max hold mode (until the trace stabilizes) shall be used.
- f) Use the 99% power bandwidth function of the instrument (if available) and report the measured bandwidth.
- g) If the instrument does not have a 99% power bandwidth function, then the trace data points are recovered and directly summed in linear power terms. The recovered amplitude data points, beginning at the lowest frequency, are placed in a running sum until 0.5% of the total is reached; that frequency is recorded as the lower frequency. The process is repeated until 99.5% of the total is reached; that frequency is recorded as the upper frequency. The 99% power bandwidth is the difference between these two frequencies.
- h) The occupied bandwidth shall be reported by providing plot(s) of the measuring instrument display; the plot axes and the scale units per division shall be clearly labeled. Tabular data may be reported in addition to the plot(s).

Note

Measurements with the peak detector are also suitable to demonstrate compliance of an EUT, as long as the required resolution bandwidth is used, because peak detection will yield amplitudes equal to or greater than amplitudes measured with RMS detector. The measurement data from a spectrum analyser peak detector will represent the worst-case results (see ANSI C63.10).

Test setup: 8.3, 8.4

Test results under normal test conditions:

EUT mode	Test conditions	f_L [GHz]	f_H [GHz]	99% OBW [MHz]
Normal operating	20 °C / V_{nom}	76.074	76.920	846*

*only informative

7.3 Field strength of spurious radiation (§2.1053 & §95.3379)

Description

§2.1053 Measurements required: Field strength of spurious radiation.

(a) Measurements shall be made to detect spurious emissions that may be radiated directly from the cabinet, control circuits, power leads, or intermediate circuit elements under normal conditions of installation and operation. Curves or equivalent data shall be supplied showing the magnitude of each harmonic and other spurious emission. For this test, single sideband, independent sideband, and controlled carrier transmitters shall be modulated under the conditions specified in paragraph (c) of §2.1049, as appropriate. For equipment operating on frequencies below 890 MHz, an open field test is normally required, with the measuring instrument antenna located in the far-field at all test frequencies. In the event it is either impractical or impossible to make open field measurements (e.g. a broadcast transmitter installed in a building) measurements will be accepted of the equipment as installed. Such measurements must be accompanied by a description of the site where the measurements were made showing the location of any possible source of reflections which might distort the field strength measurements. Information submitted shall include the relative radiated power of each spurious emission with reference to the rated power output of the transmitter, assuming all emissions are radiated from halfwave dipole antennas.

Limits

§95.3379 76-81 GHz Band Radar Service unwanted emissions limits.

(a) The power density of any emissions outside the 76-81 GHz band shall consist solely of spurious emissions and shall not exceed the following:

(1) Radiated emissions below 40 GHz shall not exceed the field strength as shown in the following emissions table.

Frequency [MHz]	Field Strength [$\mu\text{V}/\text{m}$] / [dB $\mu\text{V}/\text{m}$]	Measurement distance [m]
0.009 – 0.490	2400/F[kHz]	300
0.490 – 1.705	24000/F[kHz]	30
1.705 – 30.0	30.0 / 29.5	30
30 – 88	100 / 40.0	3
88 – 216	150 / 43.5	3
216 – 960	200 / 46.0	3
960 – 40 000	500 / 54.0	3

(2) The power density of radiated emissions outside the 76-81 GHz band above 40.0 GHz shall not exceed the following, based on measurements employing an average detector with a 1 MHz RBW:

Frequency [GHz]	Power Density / EIRP	Measurement distance [m]
40 – 200	600 pW/cm ² → -1.7 dBm	3
200 – 243	1000 pW/cm ² → +0.5 dBm	3

Note

Measurements with the peak detector are also suitable to demonstrate compliance of an EUT, as long as the required resolution bandwidth is used, because peak detection will yield amplitudes equal to or greater than amplitudes measured with RMS detector. The measurement data from a spectrum analyser peak detector will represent the worst-case results (see ANSI C63.10).

Calculation of the far field distance (Rayleigh distance):

The aperture dimensions of these horn antennas shall be small enough so that the measurement distance in meters is equal to or greater than the Rayleigh distance (i.e. $R_m = 2D^2 / \lambda$), where D is the largest linear dimension (i.e. width or height) of the antenna aperture in m and λ is the free-space wavelength in meters at the frequency of measurement.

Antenna type	Frequency range [GHz]	D [m]	Highest frequency in use [GHz]	Far field distance R_m [m]
20240-20	18.0 – 26.5	0.0520	26.5	0.478
22240-20	26.5 – 40.0	0.0342	40	0.312
23240-20	33.0 – 50.0	0.0280	50	0.261
24240-20	40.0 – 60.0	0.0230	60	0.212
25240-20	50.0 – 75.0	0.0185	75	0.171
26240-20	60.0 – 90.0	0.0150	90	0.135
27240-20	75.0 – 110	0.0124	110	0.113
28240-20	90.0 – 140	0.0100	140	0.093
29240-20	110 – 170	0.0085	170	0.082
30240-20	140 – 220	0.0068	220	0.068

Used test distances

Up to 18 GHz: 3.00 m
 18 – 60 GHz: 1.00 m

Test setup: 8.1 – 8.4 (in case of field strength measurements below 40 GHz: test distance correction factor of 20dB/decade is already considered in the plots / test result table)

Test results:

Channel / Mode	Frequency [GHz]	Detector	Test distance [m]	Level [dBm]	Limit [dBm]	Margin [dB]
----------------	-----------------	----------	-------------------	-------------	-------------	-------------

No critical emissions found. For further details see plots.

Plot no. 4: radiated emissions 9 kHz – 30 MHz, loop antenna

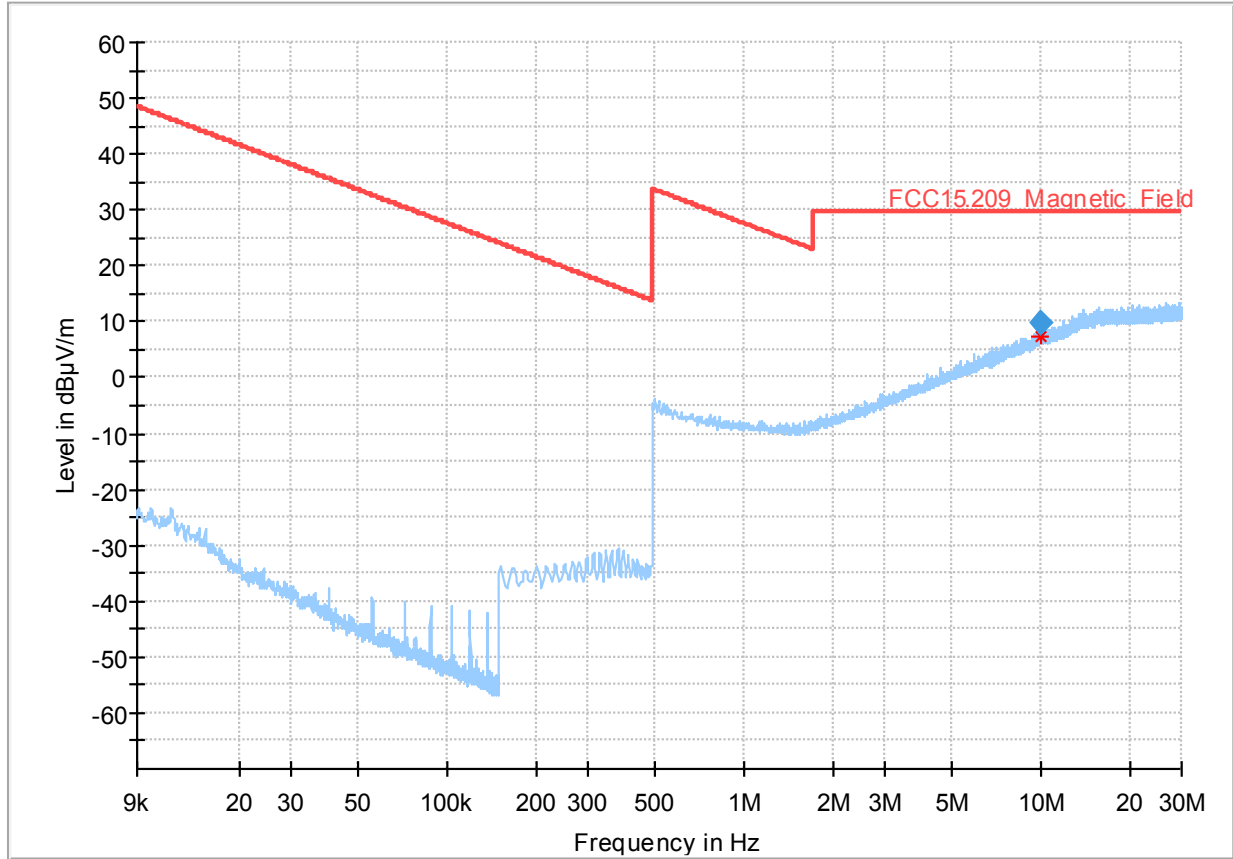

— Preview Result 1-PK+ * Critical_Freqs PK+
— FCC15.209_Magnetic_Field ◆ Final_Result QPK

Final Result

Frequency (MHz)	QuasiPeak (dBµV/m)	Limit (dBµV/m)	Margin (dB)	Meas. Time (ms)	Bandwidth (kHz)	Pol	Azimuth (deg)	Corr. (dB/m)
9.991500	9.90	29.54	19.64	100.0	9.000	V	38.0	-3.4

(continuation of the "Final_Result" table from column 15 ...)

Frequency (MHz)	Comment
9.991500	15:51:57 - 02.05.2024

Plot no. 5: radiated emissions 30 MHz – 1 GHz, polarization vertical / horizontal

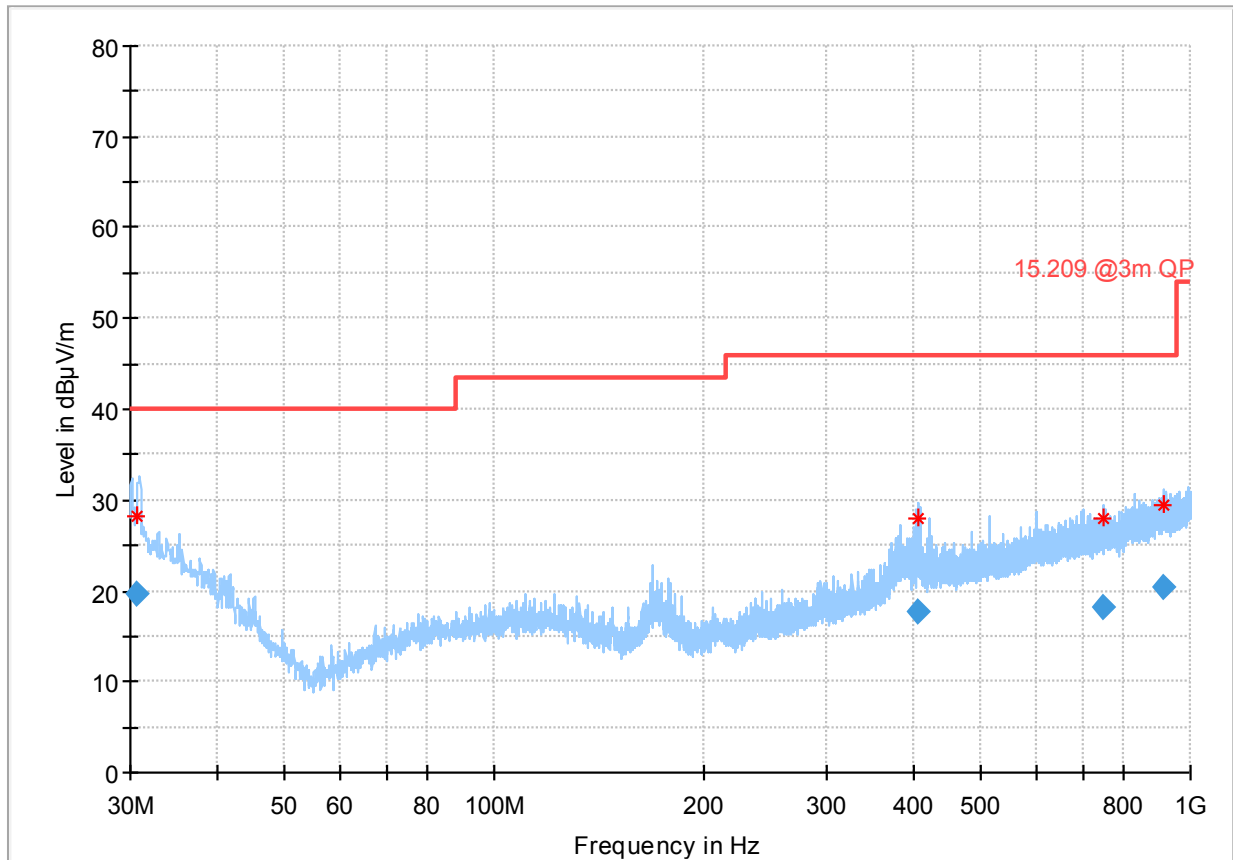

◆ Preview Result 1-PK+
◆ Final_Result QPK
 * Critical_Freqs PK+
× MaxPeak-PK+ (Single)
 — 15.209 @3m QP
+ QuasiPeak-QPK (Single)

Final_Result

Frequency (MHz)	QuasiPeak (dBµV/m)	Limit (dBµV/m)	Margin (dB)	Meas. Time (ms)	Bandwidth (kHz)	Height (cm)	Pol	Azimuth (deg)
747.668500	18.15	46.00	27.85	100.0	120.000	121.0	H	196.0
914.150500	20.37	46.00	25.63	100.0	120.000	350.0	H	95.0
30.621500	19.65	40.00	20.35	100.0	120.000	119.0	V	16.0
406.933000	17.79	46.00	28.21	100.0	120.000	119.0	V	111.0

(continuation of the "Final_Result" table from column 15 ...)

Frequency (MHz)	Elevation (deg)	Corr. (dB/m)	Comment
747.668500	0.0	21.4	15:33:00 - 02.05.2024
914.150500	0.0	23.4	15:35:11 - 02.05.2024
30.621500	0.0	20.1	15:37:27 - 02.05.2024
406.933000	0.0	16.1	15:39:30 - 02.05.2024

Plot no. 6: radiated emissions 1 GHz – 18 GHz, polarization vertical / horizontal

Spectrum Overview

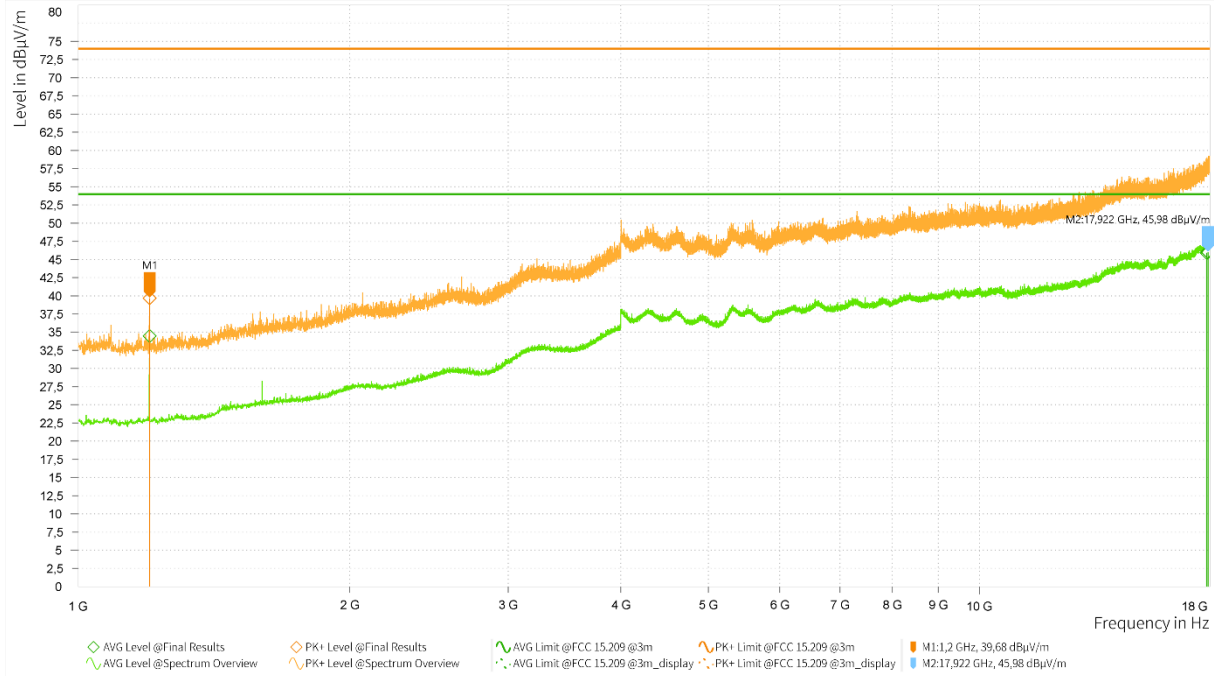

EMI Final Results (1/2)

Rg	Frequency [MHz]	PK+ Level [dBµV/m]	PK+ Limit [dBµV/m]	PK+ Margin [dB]	AVG Level [dBµV/m]	AVG Limit [dBµV/m]	AVG Margin [dB]	Correction [dB]	Polarization	Elevation [deg]	Azimuth [deg]	Antenna Height [m]
1	1.200,210	39,68	74,00	34,32	34,48	54,00	19,52	24,82	H	-15	30,1	1,50
1	17.846,895				45,92	54,00	8,08	44,06	H	60	162,2	1,50
1	17.922,030				45,98	54,00	8,02	44,27	H	30,1	368,4	1,50

EMI Final Results (2/2)

Rg	Frequency [MHz]	Meas. BW [kHz]	Time of Meas.	Source	Attachments	Comment
1	1.200,210	1.000,000	13:15:40	Critical Points		
1	17.846,895	1.000,000	12:27:35	Critical Points		
1	17.922,030	1.000,000	12:28:55	Critical Points		

8 Test Setup Description

Typically, the calibrations of the test apparatus are commissioned to and performed by an accredited calibration laboratory. The calibration intervals are determined in accordance with the DIN EN ISO/IEC 17025. In addition to the external calibrations, the laboratory executes comparison measurements with other calibrated test systems or effective verifications. Cyclically chamber inspections and range calibrations are performed. Where possible resp. necessary, RF generating and signaling equipment as well as measuring receivers and analyzers are connected to an external high-precision 10 MHz reference (GPS-based frequency standard).

In order to simplify the identification of the equipment used at some special tests, some items of test equipment and ancillaries can be provided with an identifier or number in the equipment list below (Lab/Item).

8.1 Semi Anechoic Chamber with Ground Plane

Radiated measurements are performed in vertical and horizontal plane in the frequency range 30 MHz to 1 GHz in a Semi Anechoic Chamber with a metallic ground plane. The EUT is positioned on a non-conductive test table with a height of 0.80 m above the metallic ground plane that covers the whole chamber. The receiving antennas conform to specification ANSI C63.10-2013, American National Standard for Testing Unlicensed Wireless Devices. These antennas can be moved over the height range between 1.0 m and 4.5 m in order to search for maximum field strength emitted from the EUT. The measurement distances between EUT and receiving antennas are indicated in the test setups for the various frequency ranges. For each measurement, the EUT is rotated in all three axes until the maximum field strength is received. The wanted and unwanted emissions are received by a spectrum analyzer where the detector modes and resolution bandwidths over various frequency ranges are set according to requirement ANSI C63.

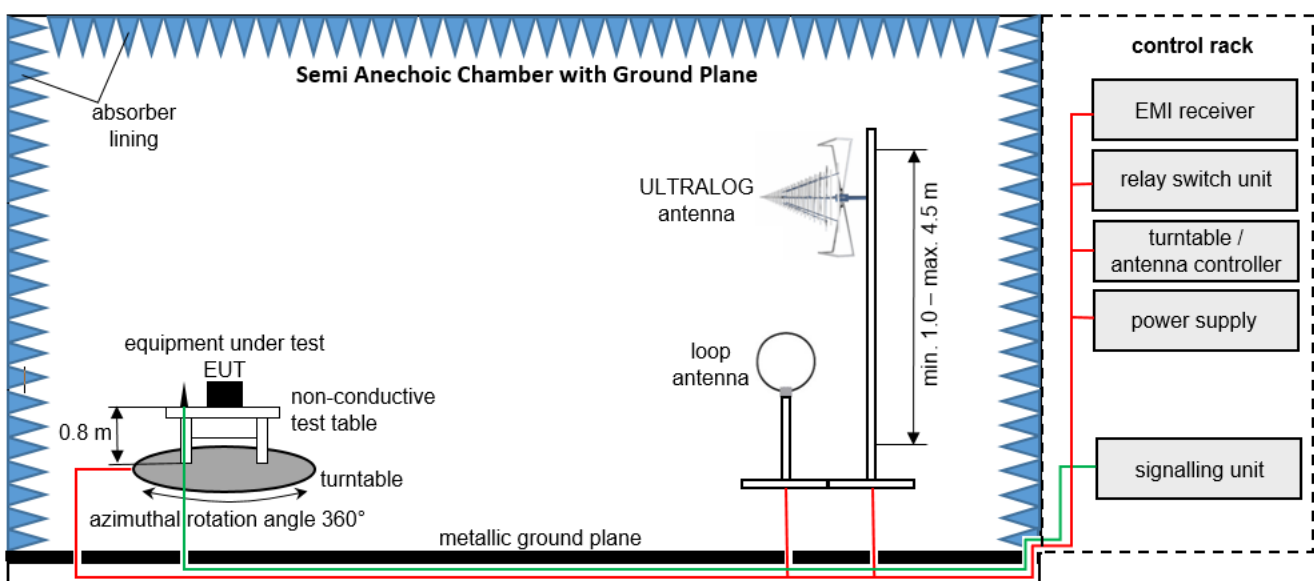

Measurement distance: ULTRALOG antenna 5 meter; loop antenna 5 meter / 3 meter / 1 meter
 EMC32 software version: 11.00.00

$$FS = UR + CL + AF$$

(FS-field strength; UR-voltage at the receiver; CL-loss of the cable; AF-antenna factor)

Example calculation:

$$FS \text{ [dB}\mu\text{V/m]} = 12.35 \text{ [dB}\mu\text{V/m]} + 1.90 \text{ [dB]} + 16.80 \text{ [dB/m]} = 31.05 \text{ [dB}\mu\text{V/m]} \text{ (35.69 } \mu\text{V/m)}$$

List of test equipment used:

No.	Equipment	Manufacturer	Type	Serial No.	IBL No.	Kind of Calibration	Calibration
1	Power Supply	Rohde & Schwarz	IN 600	101554	LAB000824	NR	–
2	Antenna	Rohde & Schwarz	HL562E	102173	LAB000673	C	2022-10-17 → 36M → 2025-10-17
3	Power Supply	Chroma	61602		LAB000507	NR	–
4	Power Supply	Elektro-Automatik GmbH & Co. KG	EA-PSI 9080-40 T	2000230001	LAB000313	NR	–
5	Test table	Innco systems GmbH	PT1208-080-RH	-	LAB000306	NR	–
6	Antenna Mast	Berlebach	Tripod HFH2-Z8 & -Z9	101762	LAB000292	NR	–
7	Compressed Air	Implotex	1-850-30	-	LAB000256	NR	–
8	EMI Test Receiver	Rohde & Schwarz	ESW26	101481	LAB000236	C	2023-07-04 → 12M → 2024-07-04
9	Semi/Fully Anechoic Chamber	Albatross Projects GmbH	Babylon 5 (SAC 5)	20168.PRB	LAB000235	CM	2022-01-31 → 36M → 2025-01-31
10	Measurement Software	Rohde & Schwarz	EMC32 V11.20		LAB000226	NR	–
11	Turntable	matur GmbH	TT2.0-2t	TT2.0-2t/921	LAB000225	NR	–
12	Antenna Mast	matur GmbH	CAM4.0-P	CAM4.0-P/316	LAB000224	NR	–
13	Controller	matur GmbH	FCU 3.0	10082	LAB000222	NR	–
14	Power Supply	Elektro-Automatik GmbH & Co. KG	EA-PS 2042-10 B	2878350292	LAB000191	NR	–
15	Open Switch and Control Platform	Rohde & Schwarz	OSP220 Base Unit 2HU	101748	LAB000149	NR	–
16	Antenna	Rohde & Schwarz	HFH2-Z2E	100954	LAB000108	C	2023-05-05 → 36M → 2026-05-05

8.2 Fully Anechoic Chamber

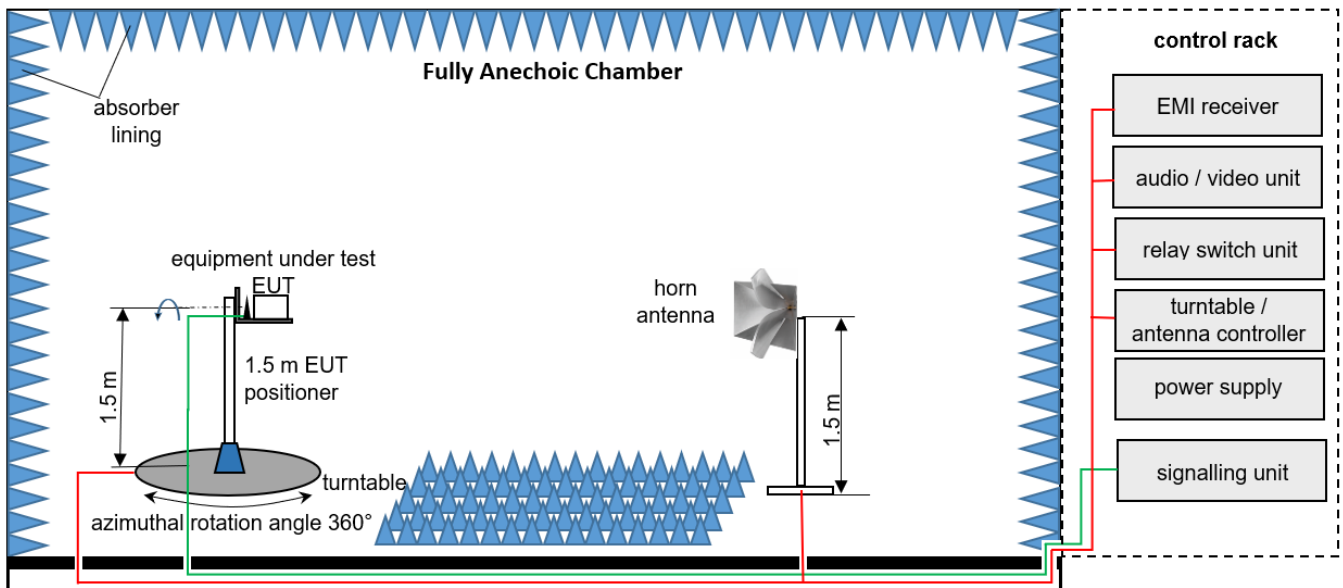

Measurement distance: tri-log antenna and horn antenna 3 meter; loop antenna 3 meter / 1 meter
EMC32 software version: 11.00.00

$$FS = UR + CA + AF$$

(FS-field strength; UR-voltage at the receiver; CA-loss of the signal path; AF-antenna factor)

Example calculation:

$$FS [dB\mu V/m] = 40.0 [dB\mu V/m] + (-35.8) [dB] + 32.9 [dB/m] = 37.1 [dB\mu V/m] (71.61 \mu V/m)$$

List of test equipment used:

No.	Equipment	Manufacturer	Type	Serial No.	IBL No.	Kind of Calibration	Calibration
1	Power Supply	Rohde & Schwarz	IN 600	101554	LAB000824	NR	-
2	Power Supply	Chroma	61602		LAB000507	NR	-
3	Power Supply	Elektro-Automatik GmbH & Co. KG	EA-PSI 9080-40 T	2000230001	LAB000313	NR	-
4	Antenna Mast	Berlebach	Tripod HFH2-Z8 & -Z9	101762	LAB000292	NR	-
5	Positioner	matur GmbH	TD 1.5-10KG		LAB000258	NR	-
6	Compressed Air	Implotex	1-850-30	-	LAB000256	NR	-
7	EMI Test Receiver	Rohde & Schwarz	ESW26	101481	LAB000236	C	2023-07-04 → 12M → 2024-07-04
8	Semi/Fully Anechoic Chamber	Albatross Projects GmbH	Babylon 5 (SAC 5)	20168.PRB	LAB000235	CM	2022-01-31 → 36M → 2025-01-31
9	Measurement Software	Rohde & Schwarz	EMC32 V11.20		LAB000226	NR	-
10	Turntable	matur GmbH	TT2.0-2t	TT2.0-2t/921	LAB000225	NR	-
11	Antenna Mast	matur GmbH	BAM4.5-P	BAM4.5-P/272	LAB000223	NR	-
12	Controller	matur GmbH	FCU 3.0	10082	LAB000222	NR	-
13	Power Supply	Elektro-Automatik GmbH & Co. KG	EA-PS 2042-10 B	2878350292	LAB000191	NR	-
14	Pre-Amplifier	Schwarzbeck Mess-Elektronik OHG	BBV 9718 C	84	LAB000169	CM	2022-05-31 → 36M → 2025-05-31
15	Antenna	Rohde & Schwarz	HF907	102899	LAB000151	C	2023-05-15 → 36M → 2026-05-15
16	Open Switch and Control Platform	Rohde & Schwarz	OSP220 Base Unit 2HU	101748	LAB000149	NR	-

8.3 Radiated measurements > 18 GHz

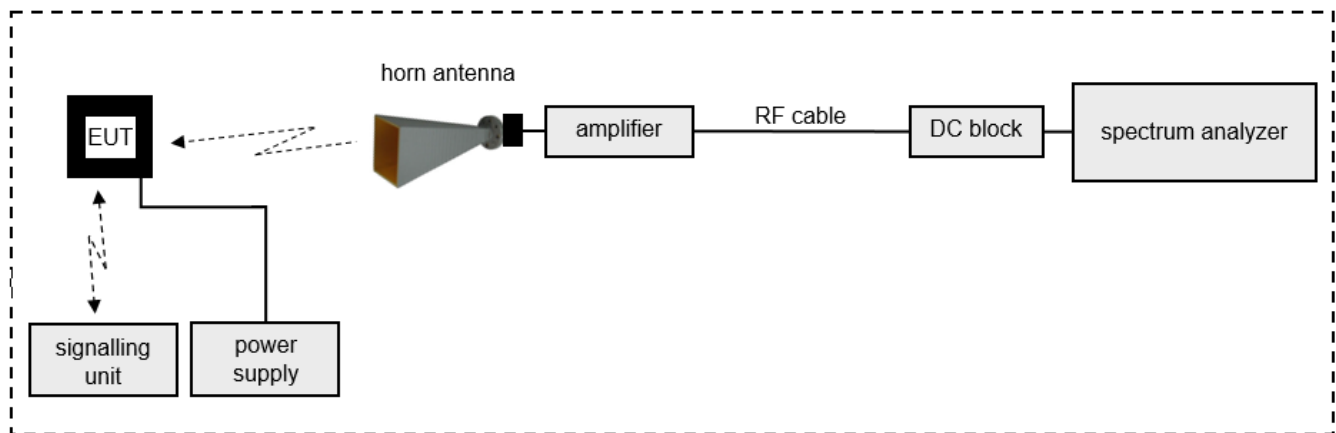

8.4 Radiated measurements > 50 GHz

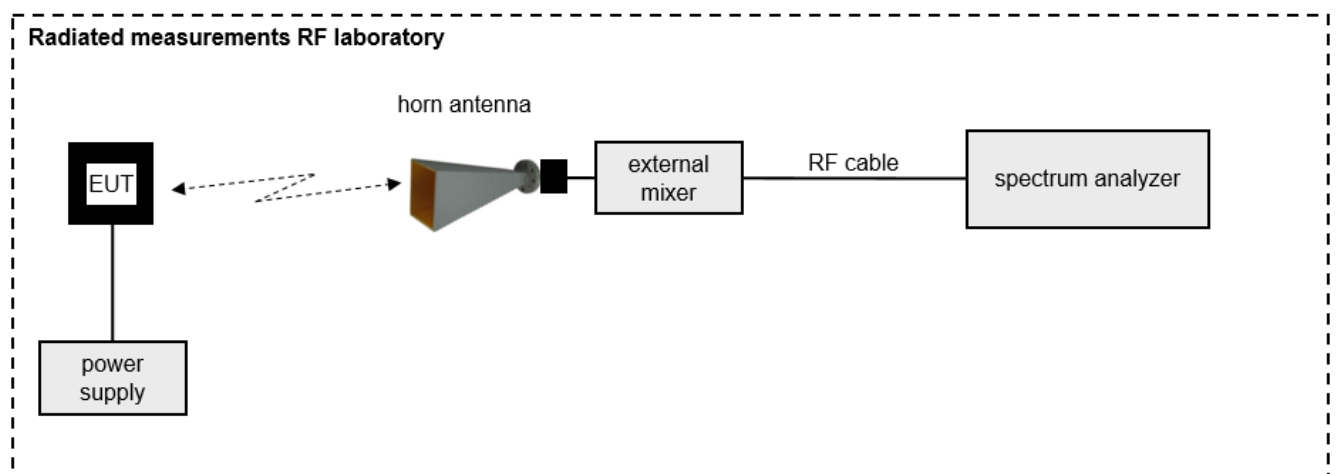

$$FS = UR + CA + AF$$

(FS-field strength; UR-voltage at the receiver; CA-loss signal path & distance correction; AF-antenna factor)

Example calculation:

$$FS [dB\mu V/m] = 40.0 [dB\mu V/m] + (-60.1) [dB] + 36.74 [dB/m] = 16.64 [dB\mu V/m] (6.79 \mu V/m)$$

$$OP = AV + D - G + CA$$

(OP-radiated output power; AV-analyzer value; D-free field attenuation of measurement distance; G-antenna gain+amplifier gain; CA-loss signal path)

Example calculation:

$$OP [dBm] = -59.0 [dBm] + 44.0 [dB] - 20.0 [dBi] + 5.0 [dB] = -30 [dBm] (1 \mu W)$$

Note: conversion loss of mixer is already included in analyzer value.

List of test equipment used:

No.	Equipment	Manufacturer	Type	Serial No.	IBL No.	Kind of Calibration	Calibration
1	Antenna	Flann Microwave Ltd	24240-20 (40.0-60.0 GHz)	275176	LAB000376	CM	2023-08-24 → 12M → 2024-08-24
2	Harmonic Mixer	Rohde & Schwarz	FS-Z60	101350	LAB000375	C	2024-04-11 → 12M → 2025-04-11
3	Absorber	Telemeter Electronic	EPP 12	-	LAB000327	NR	-
4	Test table	innco systems GmbH	PT0707-RH light	-	LAB000303	NR	-
5	Power Supply	Elektro-Automatik GmbH & Co. KG	EA-PS 2042-10 B	2878350255	LAB000189	NR	-
6	WG-Coax-Adapter	Flann Microwave Ltd	23373-TF30 UG383/U	273384	LAB000184	CM	2023-08-24 → 12M → 2024-08-24
7	WG-Coax-Adapter	Flann Microwave Ltd	22093-TF30 UG599/U	273263	LAB000183	CM	2023-08-24 → 12M → 2024-08-24
8	WG-Coax-Adapter	Flann Microwave Ltd	20093-TF30 UBR220	273373	LAB000180	CM	2023-08-24 → 12M → 2024-08-24
9	Antenna	Flann Microwave Ltd	26240-20 (60.0-90.0 GHz)	273417	LAB000135	CM	2023-08-24 → 12M → 2024-08-24
10	Oszilloscope	Rohde & Schwarz	RTE1204	300113	LAB000175	C	2023-05-19 → 12M → 2024-05-19
11	Coaxial Cable	Huber & Suhner	SF1011/1.0m	503989/1	LAB000163	CM	2023-07-17 → 12M → 2024-07-17
12	Coaxial Cable	Rosenberger	LU7-022-1000	34	LAB000154	CM	2023-07-17 → 12M → 2024-07-17
13	Coaxial Cable	Rosenberger	LU7-022-1000	33	LAB000153	CM	2023-07-17 → 12M → 2024-07-17
14	Harmonic Mixer	Rohde & Schwarz	FS-Z90	102020	LAB000113	C	2024-04-06 → 12M → 2025-04-06

8.5 Frequency error

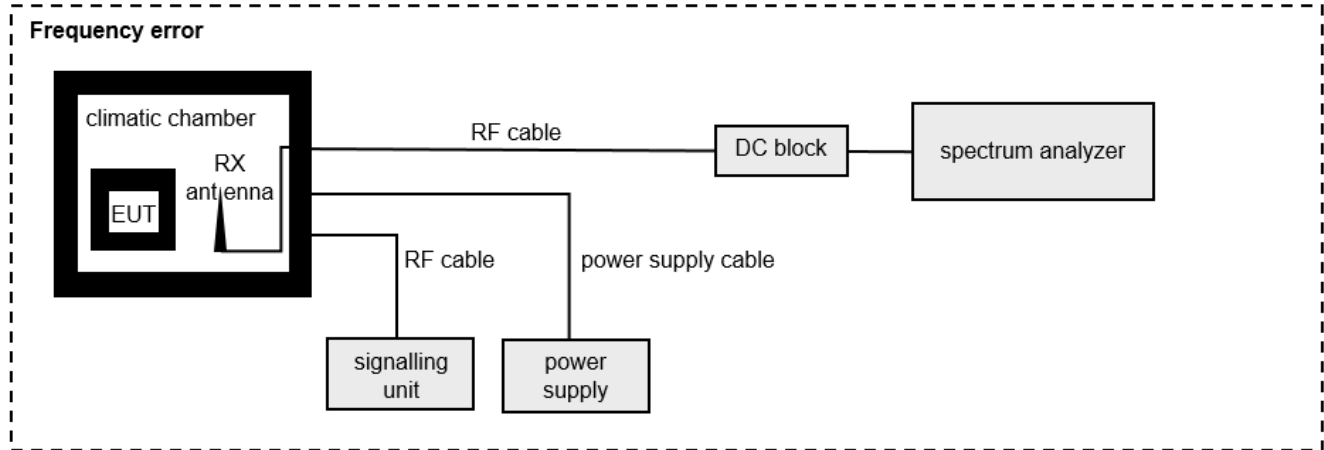

List of test equipment used:

No.	Equipment	Manufacturer	Type	Serial No.	IBL No.	Kind of Calibration	Calibration
1	Power Supply	Elektro-Automatik GmbH & Co. KG	EA-PS 2042-10 B	2878350255	LAB000189	NE	–
2	Coaxial Cable	Rosenberger	LU7-022-1000	34	LAB000154	NE	–
3	Coaxial Cable	Rosenberger	LU7-022-1000	33	LAB000153	NE	–
4	Antenna	Flann Microwave Ltd	26240-20 (60.0-90.0 GHz)	273417	LAB000135	CM	2023-08-24 → 12M → 2024-08-24
5	Harmonic Mixer	Rohde & Schwarz	FS-Z90	102020	LAB000113	C	2024-04-06 → 12M → 2025-04-06
6	Spectrum Analyser	Rohde & Schwarz	FSW50	101450	LAB000111	C	2023-07-26 → 12M → 2024-07-26
7	Climatic Chamber	CTS GmbH	T-65/50	204002	LAB000110	CM	2023-05-11 → 12M → 2024-05-11
8	Antenna Mast	Schwarzbeck Mess-Elektronik OHG	AM 9104	99	LAB000109	NE	–

9 Measurement procedures

9.1 Radiated spurious emissions from 9 kHz to 30 MHz

Test setup

- The EUT is set up according to its intended use, as described in the user manual or as defined by the manufacturer.
- In case of floor standing equipment, it is placed in the middle of the turn table.
In case of tabletop equipment it is placed on a non-conductive table with a height of 80 cm.
- Additional equipment, cables, ... necessary for testing, are positioned like under normal operation.
- Interface cables, e.g. power supply, network, ... are connected to the connection box in the turn table.
- EUT is powered on and set into operation.

Pre-scan

- Turntable performs an azimuthal rotation from 0° to 315° in 45° steps.
- For each turntable step the EMI-receiver/spectrum analyser performs a positive-peak/max-hold sweep (=worst-case). Data is transferred to EMI-software and recorded. EMI-software will show the maximum level of all single sweeps as the final result for the pre-scan.

Final measurement

- Significant emissions found during the pre-scan will be maximized by the EMI-software by rotating the turntable from 0° to 360°.
- Loop antenna is rotated with special 3D adapter set to find maximum level of emissions.
- Plot of the pre-scan with frequencies of identified emissions including levels, correction factors, turn table position and settings of measuring equipment is recorded.

Distance correction (extrapolation)

- When performing measurements on test distances other than defined in the rules, the results shall be extrapolated to the specified distance by conservatively presuming that the field strength decays at 40 dB/decade of distance in the region closer than λ in m divided by 2π (i.e., $\lambda/2\pi$), and at 20 dB/decade of distance beyond that, using the measurement of a single point at the radial angle that produces the maximum emission.

This correction is already included in the limit line of corresponding measurement plots.

Detailed requirements can be found in e.g. ANSI C63.4 / C63.10

9.2 Radiated spurious emissions from 30 MHz to 1 GHz

Test setup

- The EUT is set up according to its intended use, as described in the user manual or as defined by the manufacturer.
- In case of floor standing equipment, it is placed in the middle of the turn table.
In case of tabletop equipment it is placed on a non-conductive table with a height of 80 cm.
- Additional equipment, cables, ... necessary for testing, are positioned like under normal operation.
- Interface cables, e.g. power supply, network, ... are connected to the connection box in the turn table.
- EUT is powered on and set into operation.

Pre-scan

- Turntable performs an azimuthal rotation from 0° to 360° continuously.
- Antenna polarisation is changed (H-V / V-H) and antenna height is changed from 1 meter to 4 meters.
- For each turntable step / antenna polarisation / antenna height the EMI-receiver/spectrum analyser performs a positive-peak/max-hold sweep (=worst-case). Data is transferred to EMI-software and recorded. EMI-software will show the maximum level of all single sweeps as the final result for the pre-scan.

Final measurement

- Significant emissions found during the pre-scan will be maximized by the EMI-software based on evaluated data during the pre-scan by rotating the turntable and changing antenna height and polarisation.
- Final measurement will be performed with measuring equipment settings as defined in the applicable test standards (e.g. ANSI C6.4).
- Plot of the pre-scan with frequencies of identified emissions including levels, correction factors, turn table position, antenna polarisation and settings of measuring equipment is recorded.

Distance correction (extrapolation)

- When performing measurements on test distances other than defined in the rules, the results shall be extrapolated to the specified distance by conservatively presuming that the field strength decays at 20 dB/decade of distance beyond the region λ in m divided by 2π (i.e., $\lambda/2\pi$), using the measurement of a single point at the radial angle that produces the maximum emission.
This correction is already included in the corresponding measurement plots.

Detailed requirements can be found in e.g. ANSI C63.4 / C63.10

9.3 Radiated spurious emissions from 1 GHz to 18 GHz

Test setup

- The EUT is set up according to its intended use, as described in the user manual or as defined by the manufacturer.
- In case of floor standing equipment, it is placed in the middle of the turn table.
In case of tabletop equipment it is placed on a non-conductive table with a height of 80 cm.
- Additional equipment, cables, ... necessary for testing, are positioned like under normal operation.
- Interface cables, e.g. power supply, network, ... are connected to the connection box in the turn table.
- EUT is powered on and set into operation.

Pre-scan

- Turntable performs an azimuthal rotation from 0° to 360 continuously.
- Antenna polarisation is changed (H-V / V-H) and antenna height is changed from 1 meter to 4 meters.
- For each turntable step / antenna polarisation / antenna height the EMI-receiver/spectrum analyser performs a positive-peak/max-hold sweep (=worst-case). Data is transferred to EMI-software and recorded. EMI-software will show the maximum level of all single sweeps as the final result for the pre-scan.

Final measurement

- Significant emissions found during the pre-scan will be maximized by the EMI-software based on evaluated data during the pre-scan by rotating the turntable and changing antenna height and polarisation.
- Final measurement will be performed with measuring equipment settings as defined in the applicable test standards (e.g. ANSI C6.4).
- Plot of the pre-scan with frequencies of identified emissions including levels, correction factors, turn table position, antenna polarisation and settings of measuring equipment is recorded.

Distance correction (extrapolation)

- When performing measurements on test distances other than defined in the rules, the results shall be extrapolated to the specified distance by conservatively presuming that the field strength decays at 20 dB/decade of distance beyond the region λ in m divided by 2π (i.e., $\lambda/2\pi$), using the measurement of a single point at the radial angle that produces the maximum emission.
This correction is already included in the corresponding measurement plots.

Detailed requirements can be found in e.g. ANSI C63.4 / C63.10

9.4 Radiated spurious emissions above 18 GHz

Test setup

- The EUT is set up according to its intended use, as described in the user manual or as defined by the manufacturer.
- Additional equipment, cables, ... necessary for testing, are positioned like under normal operation.
- EUT is powered on and set into operation.
- Test distance depends on EUT size and test antenna size (farfield conditions shall be met).

Pre-scan

- The test antenna is handheld and moved carefully over the EUT to cover the EUT's whole sphere and for different polarizations of the antenna.

Final measurement

- Significant emissions found during the pre-scan will be maximized, i.e. position and antenna orientation causing the highest emissions with Peak and RMS detector
- Final measurement will be performed with measuring equipment settings as defined in the applicable test standards (e.g. ANSI C63.4 / C63.10).
- Final plot showing measurement data, levels, frequency, measuring time, bandwidth, correction factor, margin to the limit and limit is recorded.

Note

- In case of measurements with external harmonic mixers (e.g. above 50 GHz) special care is taken to avoid possible overloading of the external mixer's input.
- As external harmonic mixers may generate false images, care is taken to ensure that any emission measured by the spectrum analyzer is indeed radiated from the EUT and not internally generated by the external harmonic mixer. Signal identification feature of spectrum analyzer is used to eliminate/reduce images of the external harmonic mixer.

Distance correction (extrapolation)

- When performing measurements on test distances other than defined in the rules, the results shall be extrapolated to the specified distance by conservatively presuming that the field strength decays at 20 dB/decade of distance beyond the region λ in m divided by 2π (i.e., $\lambda/2\pi$), using the measurement of a single point at the radial angle that produces the maximum emission.
This correction is already included in the corresponding measurement plots.

Detailed requirements can be found in e.g. ANSI C63.4 / C63.10

10 MEASUREMENT UNCERTAINTIES

Radio frequency	$\leq \pm 10$ ppm
Radiated emission	$\leq \pm 6$ dB
Temperature	$\leq \pm 1$ °C
Humidity	$\leq \pm 5$ %
DC and low frequency voltages	$\leq \pm 3$ %

The indicated expanded measurement uncertainty corresponds to the standard measurement uncertainty for the measurement results multiplied by the coverage factor $k = 2$. It was determined in accordance with EA-4/01 m:2013. The true value is located in the corresponding interval with a probability of 95 %.