

77 GHz FLR Radar Sensor
User Manual
Product Model: 77V12FLR

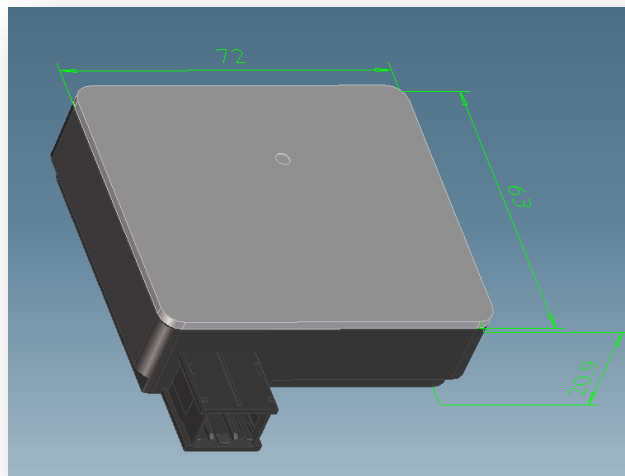

Veoneer US, Inc.
26360 American Drive
Southfield, Michigan 48034 USA
Phone: +1 248 223 0600
Fax: +1 248 223 8833

Table of Contents

1	<u>PRODUCT OVERVIEW</u>	3
1.1	PRODUCT DESCRIPTION	3
1.2	PRODUCT APPLICATION EXAMPLES	3
1.3	RADIO FREQUENCY EXPOSURE INFORMATION	3
2	<u>TYPICAL INSTALLATION</u>	4
3	<u>HARDWARE DESCRIPTION</u>	4
4	<u>SENSOR VARIANTS</u>	6
4.1	GENERIC SPECIFICATIONS	6
4.2	77 GHZ FLR RADAR SENSOR (77V12FLR)	6
5	<u>CONFORMANCE STATEMENTS</u>	7
5.1	USA	7
5.2	CANADA	7
6	<u>REVISION HISTORY</u>	7

Table of Figures

FIGURE 1 TYPICAL VEHICLE INSTALLATION.....	4
FIGURE 2 GENERIC SENSOR.....	4
FIGURE 3 SENSOR EXPLODED VIEW.....	4
FIGURE 4 TYPICAL FLR INSTALLATION.....	5

1 Product Overview

1.1 Product Description

The products described here are part of a family of radars offered by Veoneer. They are intended for automotive use, operating in the 76-77 GHz band.

The radars are integrated into a vehicle to enhance vehicle safety systems. They can be integrated as a standalone sensor or sensors, or as part of more complex system that also may include cameras, lidar, and other type of sensors to provide features like Automatic Cruise Control, Automatic Emergency Break, Free Space Detections and other Autonomous Driving functions.

1.2 Product Application Examples

The product can be used, but is not limited to the following applications:

- Autonomous drive systems
- Automatic braking systems
- Lane change warning
- Adaptive cruise control
- Collision prevention systems
- Automatic lane change systems
- Pedestrian and Bicycle collision prevention
- Etc.

1.3 Radio Frequency Exposure Information

This equipment should be operated at a minimum distance of 20 cm from the user.

NOTE: This equipment complies with FCC and IC radiation exposure limits set forth for an uncontrolled environment. This equipment should be installed and operated with minimum distance of 20 cm between the radiator and your body. This transmitter must not be co-located or operating in conjunction with any other antenna or transmitter.

Cet équipement est conforme aux limites d'exposition aux rayonnements IC établies pour un environnement non contrôlé. Cet équipement doit être installé et utilisé avec un minimum de 20 cm de distance entre la source de rayonnement et votre corps. Ce transmetteur ne doit pas être placé au même endroit ou utilisé simultanément avec un autre transmetteur ou antenne.

2 Typical Installation

The radar is typically installed in the positions of the vehicle depicted in Figure 1 often mounted behind a bumper or emblem.

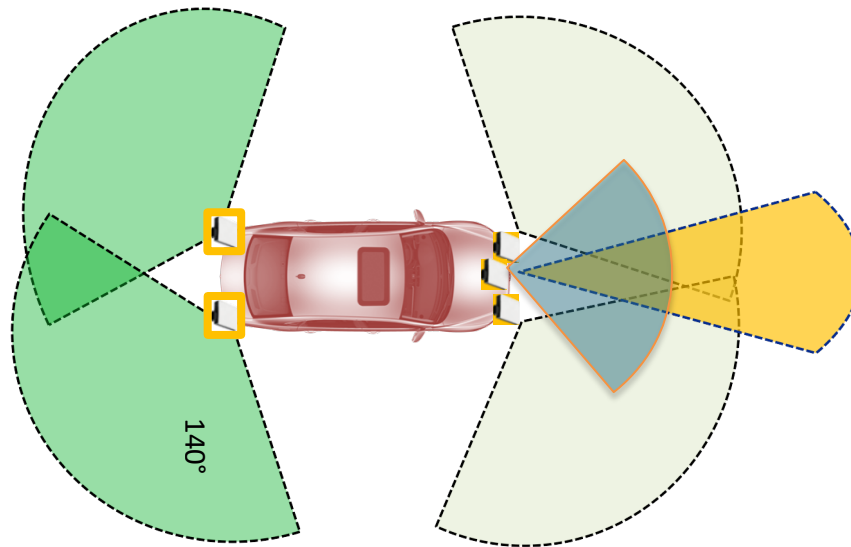

Figure 1: Typical Installation Positions

3 Hardware Description

The radar assembly consists of 2 PCB boards, one containing all the RF components, antennas and analog to digital converters and the other containing all that is necessary for signal processing and communications with the vehicle and power.

The boards are assembled into a plastic housing that is laser welded together. The sensor has no serviceable parts and can't be opened without permanent damage.

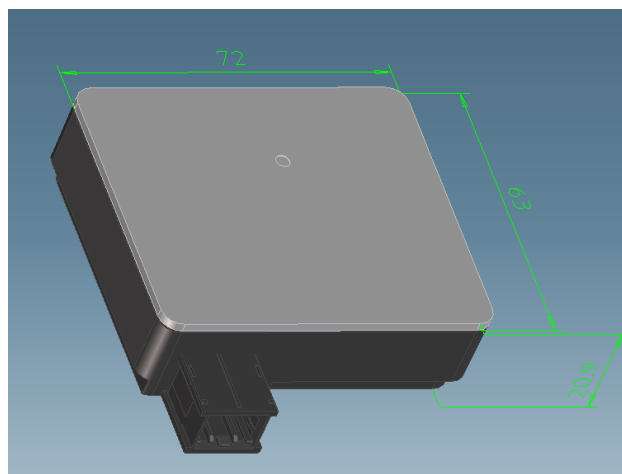

Figure 2: Generic Sensor

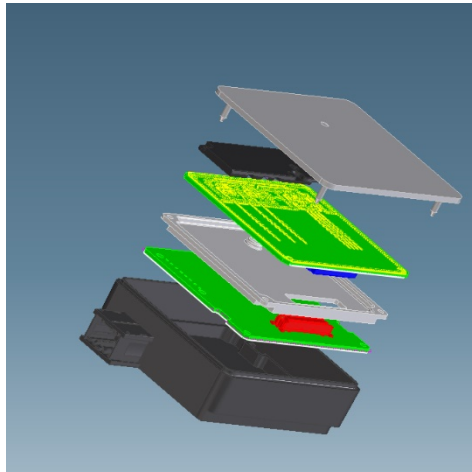

Figure 3: Sensor Exploded View

4 Sensor Variants

4.1 Generic Specifications

Sensor Specifications & Functions	Value	Unit
Frequency Band	76-77	GHz
Size	72x63x19	mm
Power Dissipation	5.5	W
Weight	<150	g
Vehicle Interface	CAN/CAN-FD	
Cycle Time	40/50	ms
IP Class	IPX9K	
Vehicle Physical Interface	Standard is 8 pin USCAR / Yazaki / Delphi	
Operating Temperature	-40 to 85	C
Input Operating Voltage	8 – 17	V

NOTE: It is recommended that the vehicle be equipped with an external safeguard to protect against an overcurrent or overload event. In-vehicle installation to include a cable/fuse assembly rated at 4 Amps, servicing no more than two sensors per assembly.

4.2 77 GHz FLR Radar Sensor (77V12FLR)

This variant of the sensor is intended for front looking radar applications. The Front Looking Radar (FLR) is installed typically behind the emblem/Logo of the car or behind the front bumper as shown in Figure 1.

To support various features, the sensor simultaneously provides two coverage configurations: a short range with wide field of view (FOV) coverage and a mid-range with narrower FOV coverage. The mid-range provides a range long enough to support the Legal Speed ACC function. Elevation discrimination is provided as well (*not depicted*).

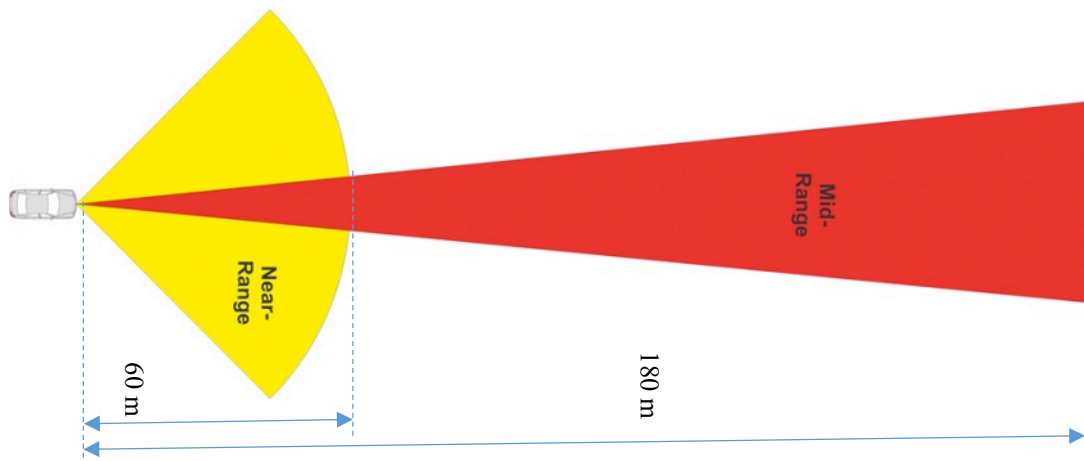

Figure 4: Typical FLR Vehicle Installation

Range	180m
FOV	+/-70 degrees
Center Frequency	76.5GHz
Bandwidth	840 MHz
Tx_on/off	60us/30us
Duty Cycle	38%

5 Conformance Statements

5.1 USA

This device complies with Part 15 of the FCC Rules. Operation is subject to the following two conditions: (1) this device may not cause harmful interference, and (2) this device must accept any interference received, including interference that may cause undesired operation. CAUTION TO USERS Changes or modifications not expressly approved by the party responsible for compliance could void the user's authority to operate the equipment.

Additionally, it should be mentioned, that the integrator is advised to have this statement in their user manual as well.

5.2 Canada

This device contains license-exempt transmitter(s)/receiver(s) that comply with Innovation, Science and Economic Development Canada's license-exempt RSS(s). Operation is subject to the following two conditions: (1) This device may not cause interference. (2) This device must accept any interference, including interference that may cause undesired operation of the device.

L'émetteur/récepteur exempt de licence contenu dans le présent appareil est conforme aux CNR d'Innovation, Sciences et Développement économique Canada applicables aux appareils radio exempts de licence. L'exploitation est autorisée aux deux conditions suivantes : 1) L'appareil ne doit pas produire de brouillage; 2) L'appareil doit accepter tout brouillage radioélectrique subi, même si le brouillage est susceptible d'en compromettre le fonctionnement.

6 Revision History

The revision number in table below is the PLM revision and version number. The Description/Comment is the same description that is found in PLM in check comment.

Revision	Date	Author(s)	Description/comment
000 v1	2018-07-22	E Martony	Draft
001 v1	2019-01-25	C O'Neill	Initial Release
001 v2	2019-03-15	C O'Neill	Add Note & Conformity Statements
001 v3	2019-05-24	C O'Neill	Updated Power Dissipation value
001 v4	2019-05-28	C O'Neill	Removed Power Consumption value