

FCC Test Report

Report No.: RF150417C34A-1

FCC ID: WT8OM5PAC

Test Model: OM5P-AC

Received Date: Dec. 18, 2015

Test Date: Jan. 12 ~ Jan. 23, 2016

Issued Date: Jan. 25, 2016

Applicant: Open Mesh, Inc.

Address: 5 Centerpointe Drive, Suite 400, Lake Oswego, Oregon, USA 97035

Issued By: Bureau Veritas Consumer Products Services (H.K.) Ltd., Taoyuan Branch

Lab Address: No. 47-2, 14th Ling, Chia Pau Vil., Lin Kou Dist., New Taipei City, Taiwan, R.O.C.

Test Location: No.19, Hwa Ya 2nd Rd., Wen Hwa Vil., Kwei Shan Dist., Taoyuan City 33383, TAIWAN (R.O.C.)



This report is for your exclusive use. Any copying or replication of this report to or for any other person or entity, or use of our name or trademark, is permitted only with our prior written permission. This report sets forth our findings solely with respect to the test samples identified herein. The results set forth in this report are not indicative or representative of the quality or characteristics of the lot from which a test sample was taken or any similar or identical product unless specifically and expressly noted. Our report includes all of the tests requested by you and the results thereof based upon the information that you provided to us. You have 60 days from date of issuance of this report to notify us of any material error or omission caused by our negligence, provided, however, that such notice shall be in writing and shall specifically address the issue you wish to raise. A failure to raise such issue within the prescribed time shall constitute your unqualified acceptance of the completeness of this report, the tests conducted and the correctness of the report contents. Unless specific mention, the uncertainty of measurement has been explicitly taken into account to declare the compliance or non-compliance to the specification. The report must not be used by the client to claim product certification, approval, or endorsement by TAF or any government agencies.

Table of Contents

Release Control Record	4
1 Certificate of Conformity	5
2 Summary of Test Results	6
2.1 Measurement Uncertainty.....	6
2.2 Modification Record.....	6
3 General Information	7
3.1 General Description of EUT.....	7
3.2 Description of Test Modes.....	9
3.2.1 Test Mode Applicability and Tested Channel Detail.....	10
3.3 Duty Cycle of Test Signal.....	12
3.4 Description of Support Units.....	13
3.4.1 Configuration of System under Test.....	14
3.5 General Description of Applied Standards.....	15
4 Test Types and Results	16
4.1 Radiated Emission and Bandedge Measurement.....	16
4.1.1 Limits of Radiated Emission and Bandedge Measurement.....	16
4.1.2 Test Instruments.....	17
4.1.3 Test Procedures.....	18
4.1.4 Deviation from Test Standard.....	18
4.1.5 Test Set Up.....	19
4.1.6 EUT Operating Conditions.....	19
4.1.7 Test Results.....	20
4.2 Conducted Emission Measurement.....	50
4.2.1 Limits of Conducted Emission Measurement.....	50
4.2.2 Test Instruments.....	50
4.2.3 Test Procedures.....	51
4.2.4 Deviation from Test Standard.....	51
4.2.5 Test Setup.....	51
4.2.6 EUT Operating Conditions.....	51
4.2.7 Test Results.....	52
4.3 Transmit Power Measurement.....	56
4.3.1 Limits of Transmit Power Measurement.....	56
4.3.2 Test Setup.....	56
4.3.3 Test Instruments.....	56
4.3.4 Test Procedure.....	57
4.3.5 Deviation from Test Standard.....	57
4.3.6 EUT Operating Conditions.....	57
4.3.7 Test Result.....	58
4.4 Peak Power Spectral Density Measurement.....	65
4.4.1 Limits of Peak Power Spectral Density Measurement.....	65
4.4.2 Test Setup.....	65
4.4.3 Test Instruments.....	65
4.4.4 Test Procedures.....	65
4.4.5 Deviation from Test Standard.....	66
4.4.6 EUT Operating Conditions.....	66
4.4.7 Test Results.....	67
4.5 Frequency Stability.....	73
4.5.1 Limits of Frequency Stability Measurement.....	73
4.5.2 Test Setup.....	73
4.5.3 Test Instruments.....	73
4.5.4 Test Procedure.....	73
4.5.5 Deviation from Test Standard.....	73
4.5.6 EUT Operating Condition.....	73

4.5.7 Test Results	74
4.6 6dB Bandwidth Measurement	75
4.6.1 Limits of 6dB Bandwidth Measurement	75
4.6.2 Test Setup	75
4.6.3 Test Instruments	75
4.6.4 Test Procedure	75
4.6.5 Deviation from Test Standard	75
4.6.6 EUT Operating Condition	75
4.6.7 Test Results	76
5 Pictures of Test Arrangements	78
Appendix – Information on the Testing Laboratories	79

Draft



Release Control Record

Issue No.	Description	Date Issued
RF150417C34A-1	Original release	Jan. 25, 2016

Draft

1 Certificate of Conformity

Product: Wireless Access Point
Brand: Open Mesh
Test Model: OM5P-AC
Sample Status: Engineering Sample
Applicant: Open Mesh, Inc.
Test Date: Jan. 12 ~ Jan. 23, 2016
Standards: 47 CFR FCC Part 15, Subpart E (Section 15.407)
ANSI C63.10:2013

The above equipment has been tested by **Bureau Veritas Consumer Products Services (H.K.) Ltd., Taoyuan Branch**, and found compliance with the requirement of the above standards. The test record, data evaluation & Equipment Under Test (EUT) configurations represented herein are true and accurate accounts of the measurements of the sample's EMC characteristics under the conditions specified in this report.

Prepared by : Celine Chou , **Date:** Jan. 25, 2016
Celine Chou / Specialist

Approved by : Ken Liu , **Date:** Jan. 25, 2016
Ken Liu / Senior Manager

2 Summary of Test Results

47 CFR FCC Part 15, Subpart E (Section 15.407)			
FCC Clause	Test Item	Result	Remarks
15.207 15.407(b)(6)	AC Power Conducted Emissions	Pass	Meet the requirement of limit. Minimum passing margin is -8.80dB at 0.32187MHz.
15.407(b) (1/2/3/4/6)	Radiated Emissions & Band Edge Measurement	Pass	Meet the requirement of limit. Minimum passing margin is -0.1dB at 11650.00MHz.
15.407(a)(1/2 /3)	Max Average Transmit Power	Pass	Meet the requirement of limit.
15.407(a)(1/2 /3)	Peak Power Spectral Density	Pass	Meet the requirement of limit.
15.407(e)	6dB bandwidth	Pass	Meet the requirement of limit. (U-NII-3 Band only)
15.407(g)	Frequency Stability	Pass	Meet the requirement of limit.
15.203	Antenna Requirement	Pass	Antenna connector is i-pex(MHF) not a standard connector.

2.1 Measurement Uncertainty

Where relevant, the following measurement uncertainty levels have been estimated for tests performed on the EUT as specified in CISPR 16-4-2:

Measurement	Frequency	Expanded Uncertainty (k=2) (±)
Conducted Emissions at mains ports0	150kHz ~ 30MHz	2.44 dB
Radiated Emissions up to 1 GHz	30MHz ~ 200MHz	3.86 dB
	200MHz ~1000MHz	3.87 dB
Radiated Emissions above 1 GHz	1GHz ~ 18GHz	2.29 dB
	18GHz ~ 40GHz	2.29 dB

2.2 Modification Record

There were no modifications required for compliance.

3 General Information

3.1 General Description of EUT

Product	Wireless Access Point
Brand	Open Mesh
Test Model	OM5P-AC
Status of EUT	Engineering sample
Power Supply Rating	DC Input 12 ~ 24V 12 ~ 24Vdc from POE 48Vdc from POE
Modulation Type	256QAM, 64QAM, 16QAM, QPSK, BPSK for OFDM
Modulation Technology	OFDM
Transfer Rate	802.11a: 54.0/ 48.0/ 36.0/ 24.0/ 18.0/ 12.0/ 9.0/ 6.0Mbps 802.11n: up to 300.0Mbps 802.11ac: up to 866.7Mbps
Operating Frequency	5180 ~ 5240MHz, 5745 ~ 5825MHz
Number of Channel	5180 ~ 5240MHz: 4 for 802.11a, 802.11n (20MHz), 802.11ac (20MHz) 2 for 802.11n (40MHz), 802.11ac (40MHz) 1 for 802.11ac (80MHz) 5745 ~ 5825MHz: 5 for 802.11a, 802.11n (20MHz), 802.11ac (20MHz) 2 for 802.11n (40MHz), 802.11ac (40MHz) 1 for 802.11ac (80MHz)
Output Power	5180 ~ 5240MHz: 174.641mW 5745 ~ 5825MHz: 160.410mW
Antenna Type	Refer to Note
Antenna Connector	Refer to Note
Accessory Device	N/A
Data Cable Supplied	N/A

Note:

1. This report is prepared for FCC class II permissive change. The difference compared with the original report (BV ADT report no.: RF150417C34-1) are list as below:

- Converting the DTS filing from 15.247 to 15.407 under new rule
- Updating U-NII filing to under new rules
- Changing PCB RF layout (only effect RX only) and thermal pad
- Adding console pin
- Changing appearance of EUT
- Changing capacitance and resistor (for ISN LAN Port)

Therefore the EUT is re-tested in this report.

2. The EUT incorporates a MIMO function. Physically, the EUT provides 2 completed transmitters and 2 receivers.

Modulation Mode	TX Function
802.11a	1TX (Fixed Ant. A)
802.11n (20MHz)	2TX
802.11n (40MHz)	2TX
802.11ac (20MHz)	2TX
802.11ac (40MHz)	2TX
802.11ac (80MHz)	2TX

3. The EUT uses following antennas.

No.	Ant. Type	Connecter Type	Antenna Gain (dBi)
A	PIFA	i-pex(MHF)	2.90
B			3.38

4. In this test report, the EUT consumes power from the following adapter and POE (for support unit only).

Adapter	
Brand	DVE
Model	DSA-12PFA-09 FUS 120100
Input Power	100-240Vac, 50/60Hz, 0.5A
Output Power	12Vdc, 1A
Power Line	1.5m cable without core attached on adapter

POE	
Brand	NA
Model	APOE02-WM
Power Rating	18-24Vdc, 1A

POE's adapter	
Brand	PEC
Model	PA1024-240IB100
Input Power	100-240Vac, 50-60Hz, 0.6A
Output Power	24Vdc, 1A, 24W Max.
Power Line	1.55m cable without core attached on adapter

3.2 Description of Test Modes

For 5180 ~ 5240MHz

4 channels are provided for 802.11a, 802.11n (20MHz), 802.11ac (20MHz):

Channel	Frequency	Channel	Frequency
36	5180 MHz	44	5220 MHz
40	5200 MHz	48	5240 MHz

2 channels are provided for 802.11n (40MHz), 802.11ac (40MHz):

Channel	Frequency	Channel	Frequency
38	5190 MHz	46	5230 MHz

1 channel is provided for 802.11ac (80MHz):

Channel	Frequency
42	5210MHz

For 5745 ~ 5825MHz:

5 channels are provided for 802.11a, 802.11n (20MHz), 802.11ac (20MHz):

Channel	Frequency	Channel	Frequency
149	5745MHz	161	5805MHz
153	5765MHz	165	5825MHz
157	5785MHz		

2 channels are provided for 802.11n (40MHz), 802.11ac (40MHz):

Channel	Frequency	Channel	Frequency
151	5755MHz	159	5795MHz

1 channel is provided for 802.11ac (80MHz):

Channel	Frequency
155	5775MHz

3.2.1 Test Mode Applicability and Tested Channel Detail

EUT CONFIGURE MODE	APPLICABLE TO				DESCRIPTION
	RE \geq 1G	RE $<$ 1G	PLC	APCM	
A	√	√	√	√	Powered by adapter
B	-	√	√	-	Powered by POE

Where **RE \geq 1G**: Radiated Emission above 1GHz & Bandedge Measurement
RE $<$ 1G: Radiated Emission below 1GHz
PLC: Power Line Conducted Emission
APCM: Antenna Port Conducted Measurement

Note:

1. The EUT had been pre-tested on the positioned of each 3 axis. The worst case was found when positioned on **X-plane**.
2. "-" means no effect.

Radiated Emission Test (Above 1GHz):

- Pre-Scan has been conducted to determine the worst-case mode from all possible combinations between available modulations, data rates and antenna ports (if EUT with antenna diversity architecture).
- Following channel(s) was (were) selected for the final test as listed below.

EUT CONFIGURE MODE	MODE	FREQ. BAND (MHz)	AVAILABLE CHANNEL	TESTED CHANNEL	MODULATION TECHNOLOGY	MODULATION TYPE	DATA RATE (Mbps)
A	802.11a	5180-5240	36 to 48	36, 40, 48	OFDM	BPSK	6.0
A	802.11n (20MHz)		36 to 48	36, 40, 48	OFDM	BPSK	7.2
A	802.11n (40MHz)		38 to 46	38, 46	OFDM	BPSK	15.0
A	802.11ac (20MHz)		36 to 48	36, 40, 48	OFDM	BPSK	7.2
A	802.11ac (40MHz)		38 to 46	38, 46	OFDM	BPSK	15.0
A	802.11ac (80MHz)		42	42	OFDM	BPSK	58.5
A	802.11a		5745-5825	149 to 165	149, 157, 165	OFDM	BPSK
A	802.11n (20MHz)	149 to 165		149, 157, 165	OFDM	BPSK	7.2
A	802.11n (40MHz)	151 to 159		151, 159	OFDM	BPSK	15.0
A	802.11ac (20MHz)	149 to 165		149, 157, 165	OFDM	BPSK	7.2
A	802.11ac (40MHz)	151 to 159		151, 159	OFDM	BPSK	15.0
A	802.11ac (80MHz)	155		155	OFDM	BPSK	58.5

Radiated Emission Test (Below 1GHz):

- Pre-Scan has been conducted to determine the worst-case mode from all possible combinations between available modulations, data rates and antenna ports (if EUT with antenna diversity architecture).
- Following channel(s) was (were) selected for the final test as listed below.

EUT CONFIGURE MODE	MODE	FREQ. BAND (MHz)	AVAILABLE CHANNEL	TESTED CHANNEL	MODULATION TECHNOLOGY	MODULATION TYPE	DATA RATE (Mbps)
A, B	802.11a	5180-5240	36 to 48	36	OFDM	BPSK	6.0
		5745-5825	149 to 165				

Power Line Conducted Emission Test:

- Pre-Scan has been conducted to determine the worst-case mode from all possible combinations between available modulations, data rates and antenna ports (if EUT with antenna diversity architecture).
- Following channel(s) was (were) selected for the final test as listed below.

EUT CONFIGURE MODE	MODE	FREQ. BAND (MHz)	AVAILABLE CHANNEL	TESTED CHANNEL	MODULATION TECHNOLOGY	MODULATION TYPE	DATA RATE (Mbps)
A, B	802.11a	5180-5240	36 to 48	36	OFDM	BPSK	6.0
		5745-5825	149 to 165				

Antenna Port Conducted Measurement:

- This item includes all test value of each mode, but only includes spectrum plot of worst value of each mode.
- Pre-Scan has been conducted to determine the worst-case mode from all possible combinations between available modulations, data rates and antenna ports (if EUT with antenna diversity architecture).
- Following channel(s) was (were) selected for the final test as listed below.

EUT CONFIGURE MODE	MODE	FREQ. BAND (MHz)	AVAILABLE CHANNEL	TESTED CHANNEL	MODULATION TECHNOLOGY	MODULATION TYPE	DATA RATE (Mbps)
A	802.11a	5180-5240	36 to 48	36, 40, 48	OFDM	BPSK	6.0
A	802.11n (20MHz)		36 to 48	36, 40, 48	OFDM	BPSK	7.2
A	802.11n (40MHz)		38 to 46	38, 46	OFDM	BPSK	15.0
A	802.11ac (20MHz)		36 to 48	36, 40, 48	OFDM	BPSK	7.2
A	802.11ac (40MHz)		38 to 46	38, 46	OFDM	BPSK	15.0
A	802.11ac (80MHz)		42	42	OFDM	BPSK	58.5
A	802.11a	5745-5825	149 to 165	149, 157, 165	OFDM	BPSK	6.0
A	802.11n (20MHz)		149 to 165	149, 157, 165	OFDM	BPSK	7.2
A	802.11n (40MHz)		151 to 159	151, 159	OFDM	BPSK	15.0
A	802.11ac (20MHz)		149 to 165	149, 157, 165	OFDM	BPSK	7.2
A	802.11ac (40MHz)		151 to 159	151, 159	OFDM	BPSK	15.0
A	802.11ac (80MHz)		155	155	OFDM	BPSK	58.5

Test Condition:

APPLICABLE TO	ENVIRONMENTAL CONDITIONS	INPUT POWER	TESTED BY
RE_≥1G	18deg. C, 70%RH	120Vac, 60Hz	Nick Hsu
RE<1G	20deg. C, 64%RH	120Vac, 60Hz 24Vdc	Jones Chang
PLC	19deg. C, 70%RH	120Vac, 60Hz 24Vdc	Jones Chang
APCM	24deg. C, 64%RH	120Vac, 60Hz	Match Tsui

3.3 Duty Cycle of Test Signal

Duty cycle of test signal is < 98 %, duty factor is required.

802.11a: Duty cycle = 2.688/2.801 = 0.960, Duty factor = $10 \cdot \log(1/0.960) = 0.18$

802.11n (20MHz): Duty cycle = 2.512/2.599 = 0.967, Duty factor = $10 \cdot \log(1/0.967) = 0.15$

802.11n (40MHz): Duty cycle = 1.175/1.325 = 0.887, Duty factor = $10 \cdot \log(1/0.887) = 0.52$

802.11ac (20MHz): Duty cycle = 2.525/2.625 = 0.962, Duty factor = $10 \cdot \log(1/0.962) = 0.17$

802.11ac (40MHz): Duty cycle = 1.162/1.325 = 0.877, Duty factor = $10 \cdot \log(1/0.877) = 0.57$

802.11ac (80MHz): Duty cycle = 0.574/0.699 = 0.821, Duty factor = $10 \cdot \log(1/0.821) = 0.86$



3.4 Description of Support Units

The EUT has been tested as an independent unit together with other necessary accessories or support units. The following support units or accessories were used to form a representative test configuration during the tests.

ID	Product	Brand	Model No.	Serial No.	FCC ID	Remarks
A.	Notebook	DELL	E5410	1HC2XM1	FCC DoC Approved	-
B.	Adapter	DVE	DSA-12PFA-09 FUS 120100	NA	NA	For test mode A only Provided by Manufacturer
C.	POE	NA	APOE02-WM	NA	NA	For test mode B only Provided by Manufacturer
D.	POE's Adapter	PEC	PA1024-240IB100	NA	NA	For test mode B only Provided by Manufacturer
E.	Load	NA	NA	NA	NA	-

Note:

1. All power cords of the above support units are non-shielded (1.8m).
2. Item A acted as communication partners to transfer data.

ID	Descriptions	Qty.	Length (m)	Shielding (Yes/No)	Cores (Qty.)	Remarks
1.	RJ45	1	3	N	0	-
2.	Power	1	1.5	N	0	For test mode A only Attached on adapter
		1	1.55	N	0	For test mode B only Attached on adapter
3.	RJ45	1	1.8	N	0	-
4.	RJ45	1	1.8	N	0	-

3.4.1 Configuration of System under Test

Test Mode A

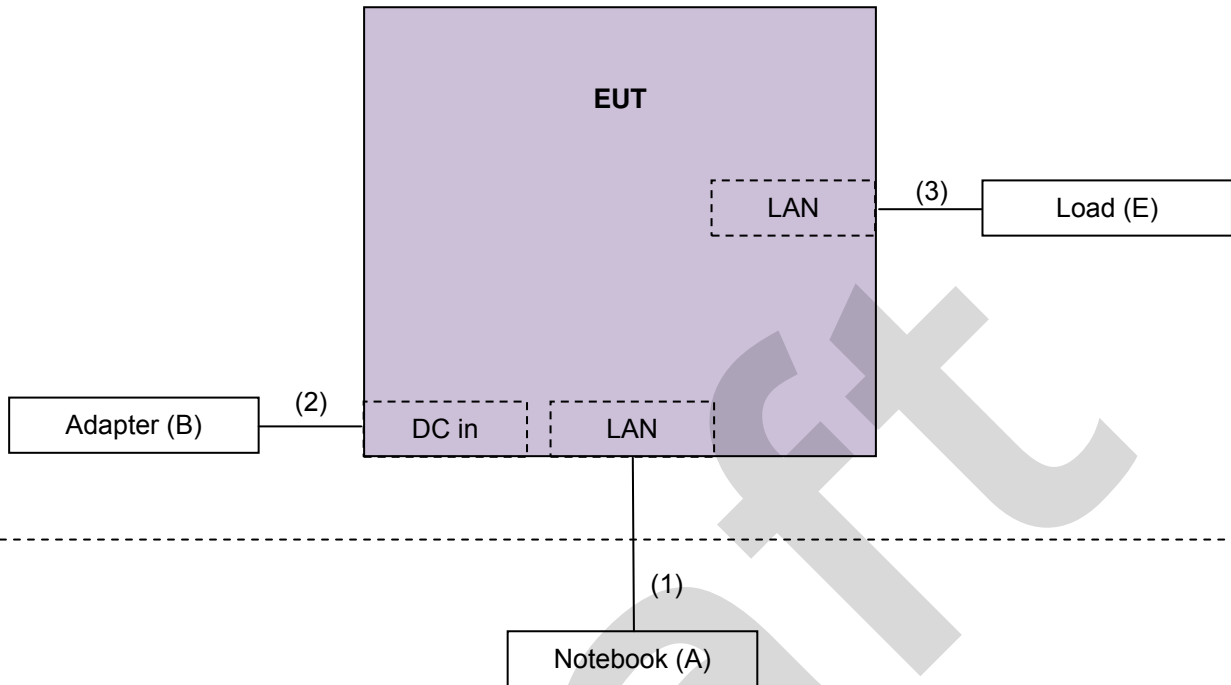

Test Mode B

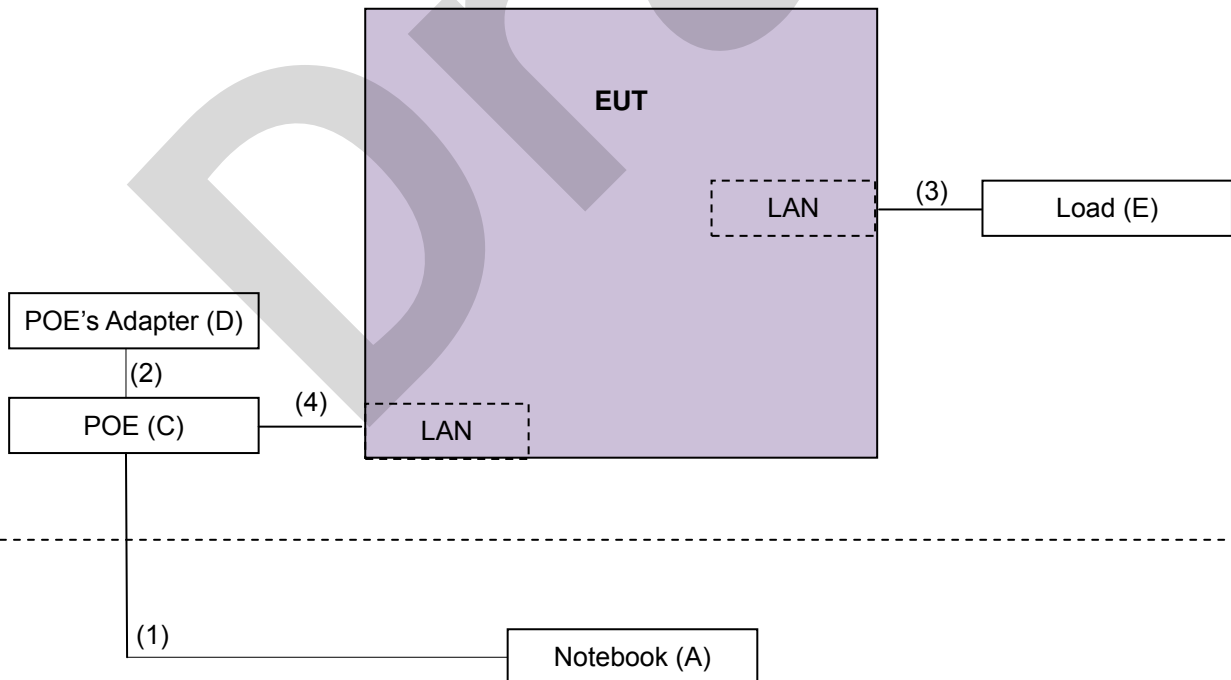

3.5 General Description of Applied Standards

The EUT is a RF Product. According to the specifications of the manufacturer, it must comply with the requirements of the following standards:

FCC Part 15, Subpart E (15.407)

789033 D02 General UNII Test Procedures New Rules v01r01

662911 D01 Multiple Transmitter Output v02r01

ANSI C63.10-2013

All test items have been performed and recorded as per the above standards.

Note: The EUT is also considered as a kind of computer peripheral, because the connection to computer is necessary for typical use. It has been verified to comply with the requirements of FCC Part 15, Subpart B, Class B (DoC). The test report has been issued separately.

Draft

4 Test Types and Results

4.1 Radiated Emission and Bandedge Measurement

4.1.1 Limits of Radiated Emission and Bandedge Measurement

Radiated emissions which fall in the restricted bands must comply with the radiated emission limits specified as below table.

Frequencies (MHz)	Field Strength (microvolts/meter)	Measurement Distance (meters)
0.009 ~ 0.490	2400/F(kHz)	300
0.490 ~ 1.705	24000/F(kHz)	30
1.705 ~ 30.0	30	30
30 ~ 88	100	3
88 ~ 216	150	3
216 ~ 960	200	3
Above 960	500	3

NOTE:

1. The lower limit shall apply at the transition frequencies.
2. Emission level (dBuV/m) = 20 log Emission level (uV/m).
3. For frequencies above 1000MHz, the field strength limits are based on average detector, however, the peak field strength of any emission shall not exceed the maximum permitted average limits, specified above by more than 20dB under any condition of modulation.

LIMITS OF UNWANTED EMISSION OUT OF THE RESTRICTED BANDS

APPLICABLE TO	LIMIT	
789033 D02 General UNII Test Procedures New Rules v01r01	FIELD STRENGTH AT 3m	
	PK:74 (dBuV/m)	AV:54 (dBuV/m)
APPLICABLE TO	EIRP LIMIT	EQUIVALENT FIELD STRENGTH AT 3m
15.407(b)(1)	PK:-27 (dBm/MHz)	PK:68.2(dBuV/m)
15.407(b)(2)		
15.407(b)(3)		
15.407(b)(4)	PK:-27 (dBm/MHz) ^{*1} PK:-17 (dBm/MHz) ^{*2}	PK: 68.2(dBuV/m) ^{*1} PK:78.2 (dBuV/m) ^{*2}

NOTE: ^{*1} beyond 10MHz of the band edge ^{*2} within 10 MHz of band edge

The following formula is used to convert the equipment isotropic radiated power (eirp) to field strength:

$$E = \frac{1000000 \sqrt{30P}}{3} \mu\text{V/m, where P is the eirp (Watts).}$$



A D T

4.1.2 Test Instruments

Description & Manufacturer	Model No.	Serial No.	Cal. Date	Cal. Due
Test Receiver ROHDE & SCHWARZ	ESIB7	100187	Apr. 10, 2015	Apr. 09, 2016
Spectrum Analyzer ROHDE & SCHWARZ	FSP40	100041	Sep. 02, 2015	Sep. 01, 2016
BILOG Antenna SCHWARZBECK	VULB9168	9168-151	Jan. 07, 2016	Jan. 06, 2017
HORN Antenna SCHWARZBECK	9120D	209	Jan. 20, 2015 Jan. 20, 2016	Jan. 19, 2016 Jan. 19, 2017
HORN Antenna SCHWARZBECK	BBHA 9170	BBHA9170241	Jan. 18, 2015 Jan. 18, 2016	Jan. 17, 2016 Jan. 17, 2017
Preamplifier Agilent	8447D	2944A10738	Oct. 18, 2015	Oct. 17, 2016
Preamplifier Agilent	8449B	3008A01964	Aug. 22, 2015	Aug. 21, 2016
RF signal cable HUBER+SUHNER	SUCOFLEX 104	Cable-CH3-03 (214378)	Aug. 22, 2015	Aug. 21, 2016
RF signal cable HUBER+SUHNER	SUCOFLEX 106	Cable-CH3-03 (309224+12738)	Aug. 22, 2015	Aug. 21, 2016
Software BV ADT	ADT_Radiated_ V7.6.15.9.4	NA	NA	NA
Antenna Tower inn-co GmbH	MA 4000	013303	NA	NA
Antenna Tower Controller BV ADT	AT100	AT93021702	NA	NA
Turn Table BV ADT	TT100	TT93021702	NA	NA
Turn Table Controller BV ADT	SC100	SC93021702	NA	NA
26GHz ~ 40GHz Amplifier	EM26400	815221	Oct. 18, 2015	Oct. 17, 2016
High Speed Peak Power Meter	ML2495A	0824011	Jul. 09, 2015	Jul. 08, 2016
Power Sensor	MA2411B	0738171	Jul. 09, 2015	Jul. 08, 2016
WIT Standard Temperature And Humidity Chamber	TH-4S-C	W981030	Jun. 08, 2015	Jun. 07, 2016

- Note: 1. The calibration interval of the above test instruments is 12 months and the calibrations are traceable to NML/ROC and NIST/USA.
2. The test was performed in HwaYa Chamber 3.
3. The horn antenna and preamplifier (model: 8449B) are used only for the measurement of emission frequency above 1GHz if tested.
4. The FCC Site Registration No. is 988962.
5. The IC Site Registration No. is IC 7450F-3.

4.1.3 Test Procedures

- a. The EUT was placed on the top of a rotating table 0.8 meters (for below 1GHz) / 1.5 meters (for above 1GHz) above the ground at 3 meter chamber room for test. The table was rotated 360 degrees to determine the position of the highest radiation.
- b. The EUT was set 3 meters away from the interference-receiving antenna, which was mounted on the top of a variable-height antenna tower.
- c. The height of antenna is varied from one meter to four meters above the ground to determine the maximum value of the field strength. Both horizontal and vertical polarizations of the antenna are set to make the measurement.
- d. For each suspected emission, the EUT was arranged to its worst case and then the antenna was tuned to heights from 1 meter to 4 meters and the rotatable table was turned from 0 degrees to 360 degrees to find the maximum reading.
- e. The test-receiver system was set to quasi-peak detect function and specified bandwidth with maximum hold mode when the test frequency is below 1 GHz.
- f. The test-receiver system was set to peak and average detect function and specified bandwidth with maximum hold mode when the test frequency is above 1 GHz. If the peak reading value also meets average limit, measurement with the average detector is unnecessary.

Note:

1. The resolution bandwidth and video bandwidth of test receiver/spectrum analyzer is 120kHz for Quasi-peak detection (QP) at frequency below 1GHz.
2. The resolution bandwidth of test receiver/spectrum analyzer is 1 MHz and the video bandwidth is 3 MHz for Peak detection (PK) at frequency above 1GHz.
3. The resolution bandwidth of test receiver/spectrum analyzer is 1MHz and the video bandwidth is 3MHz for RMS Average (Duty cycle < 98%) for Average detection (AV) at frequency above 1GHz, then the measurement results was added to a correction factor ($10 \log(1/\text{duty cycle})$).
4. The resolution bandwidth of test receiver/spectrum analyzer is 1MHz and the video bandwidth is 10Hz (Duty cycle $\geq 98\%$) for Average detection (AV) at frequency above 1GHz.
5. All modes of operation were investigated and the worst-case emissions are reported.

4.1.4 Deviation from Test Standard

No deviation.

4.1.5 Test Set Up

<Frequency Range below 1GHz>

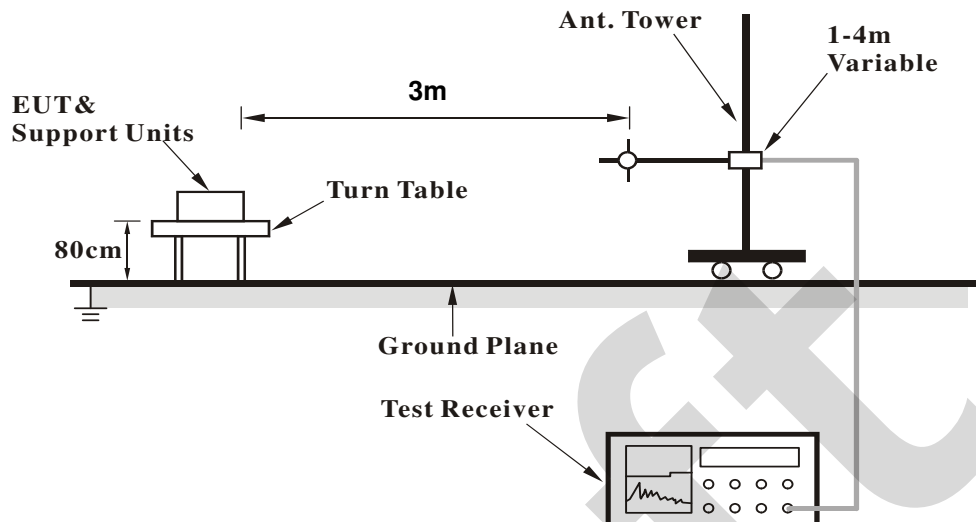

<Frequency Range above 1GHz>

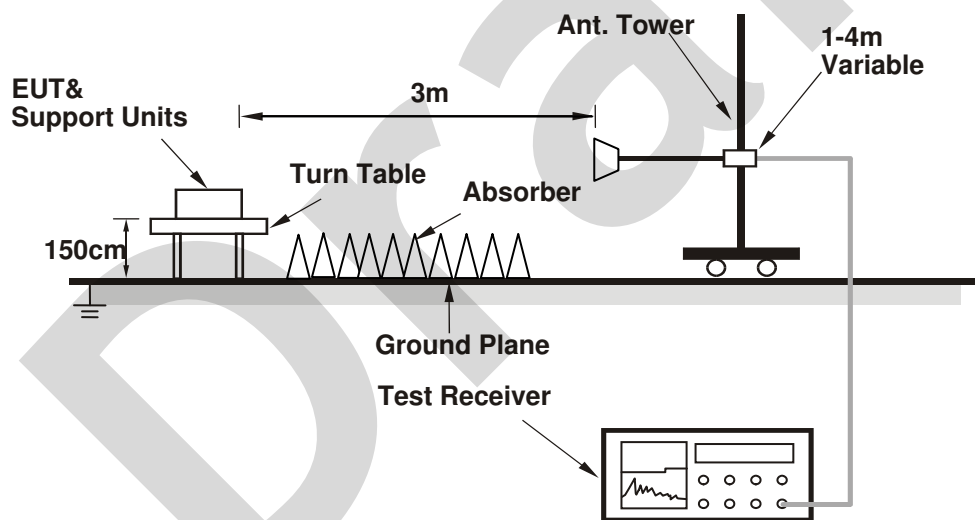

For the actual test configuration, please refer to the attached file (Test Setup Photo)

4.1.6 EUT Operating Conditions

- Placed the EUT on the testing table.
- Prepared a notebook to act as communication partner and placed it outside of testing area.
- The communication partner connected with EUT via a RJ45 cable and ran a test program (provided by manufacturer) to enable EUT under transmission condition continuously at specific channel frequency.
- The communication partner sent data to EUT by command "PING".

4.1.7 Test Results

Above 1GHz Worst-Case Data:

802.11a

CHANNEL	TX Channel 36	DETECTOR	Peak (PK)
FREQUENCY RANGE	1GHz ~ 40GHz	FUNCTION	Average (AV)

ANTENNA POLARITY & TEST DISTANCE: HORIZONTAL AT 3 M

NO.	FREQ. (MHz)	EMISSION LEVEL (dBuV/m)	LIMIT (dBuV/m)	MARGIN (dB)	ANTENNA HEIGHT (m)	TABLE ANGLE (Degree)	RAW VALUE (dBuV)	CORRECTION FACTOR (dB/m)
1	5150.00	65.6 PK	74.0	-8.4	2.44 H	272	59.40	6.20
2	5150.00	48.9 AV	54.0	-5.1	2.44 H	272	42.70	6.20
3	*5180.00	109.3 PK			2.30 H	270	69.80	39.50
4	*5180.00	98.4 AV			2.30 H	270	58.90	39.50
5	#10360.00	64.0 PK	74.0	-10.0	1.00 H	282	47.00	17.00
6	#10360.00	51.4 AV	54.0	-2.6	1.00 H	282	34.40	17.00

ANTENNA POLARITY & TEST DISTANCE: VERTICAL AT 3 M

NO.	FREQ. (MHz)	EMISSION LEVEL (dBuV/m)	LIMIT (dBuV/m)	MARGIN (dB)	ANTENNA HEIGHT (m)	TABLE ANGLE (Degree)	RAW VALUE (dBuV)	CORRECTION FACTOR (dB/m)
1	5150.00	68.6 PK	74.0	-5.4	1.03 V	271	62.40	6.20
2	5150.00	52.3 AV	54.0	-1.7	1.03 V	271	46.10	6.20
3	*5180.00	111.6 PK			1.00 V	265	72.10	39.50
4	*5180.00	101.8 AV			1.00 V	265	62.30	39.50
5	#10360.00	68.6 PK	74.0	-5.4	1.00 V	234	51.60	17.00
6	#10360.00	53.6 AV	54.0	-0.4	1.00 V	234	36.60	17.00

Remarks:

1. Emission Level(dBuV/m) = Raw Value(dBuV) + Correction Factor(dB/m)
2. Correction Factor(dB/m) = Antenna Factor(dB/m) + Cable Factor(dB)
3. The other emission levels were very low against the limit.
4. Margin value = Emission Level – Limit value
5. " * ": Fundamental frequency.
6. " # ": The radiated frequency is out of the restricted band.

CHANNEL	TX Channel 40	DETECTOR FUNCTION	Peak (PK)
FREQUENCY RANGE	1GHz ~ 40GHz		Average (AV)

ANTENNA POLARITY & TEST DISTANCE: HORIZONTAL AT 3 M

NO.	FREQ. (MHz)	EMISSION LEVEL (dBuV/m)	LIMIT (dBuV/m)	MARGIN (dB)	ANTENNA HEIGHT (m)	TABLE ANGLE (Degree)	RAW VALUE (dBuV)	CORRECTION FACTOR (dB/m)
1	*5200.00	108.9 PK			2.52 H	273	69.30	39.60
2	*5200.00	98.6 AV			2.52 H	273	59.00	39.60
3	#10400.00	63.7 PK	74.0	-10.3	1.00 H	249	46.70	17.00
4	#10400.00	50.9 AV	54.0	-3.1	1.00 H	249	33.90	17.00

ANTENNA POLARITY & TEST DISTANCE: VERTICAL AT 3 M

NO.	FREQ. (MHz)	EMISSION LEVEL (dBuV/m)	LIMIT (dBuV/m)	MARGIN (dB)	ANTENNA HEIGHT (m)	TABLE ANGLE (Degree)	RAW VALUE (dBuV)	CORRECTION FACTOR (dB/m)
1	*5200.00	111.6 PK			1.04 V	265	72.00	39.60
2	*5200.00	102.0 AV			1.04 V	265	62.40	39.60
3	#10400.00	67.8 PK	74.0	-6.2	1.01 V	235	50.80	17.00
4	#10400.00	53.7 AV	54.0	-0.3	1.01 V	235	36.70	17.00

Remarks:

1. Emission Level(dBuV/m) = Raw Value(dBuV) + Correction Factor(dB/m)
2. Correction Factor(dB/m) = Antenna Factor(dB/m) + Cable Factor(dB)
3. The other emission levels were very low against the limit.
4. Margin value = Emission Level – Limit value
5. " * ": Fundamental frequency.
6. " # ": The radiated frequency is out of the restricted band.

CHANNEL	TX Channel 48	DETECTOR FUNCTION	Peak (PK)
FREQUENCY RANGE	1GHz ~ 40GHz		Average (AV)

ANTENNA POLARITY & TEST DISTANCE: HORIZONTAL AT 3 M

NO.	FREQ. (MHz)	EMISSION LEVEL (dBuV/m)	LIMIT (dBuV/m)	MARGIN (dB)	ANTENNA HEIGHT (m)	TABLE ANGLE (Degree)	RAW VALUE (dBuV)	CORRECTION FACTOR (dB/m)
1	*5240.00	108.1 PK			2.53 H	267	68.50	39.60
2	*5240.00	98.3 AV			2.53 H	267	58.70	39.60
3	5350.00	46.9 PK	74.0	-27.1	2.27 H	283	40.50	6.40
4	5350.00	44.8 AV	54.0	-9.2	2.27 H	283	38.40	6.40
5	#10480.00	62.8 PK	74.0	-11.2	1.19 H	249	44.80	18.00
6	#10480.00	51.0 AV	54.0	-3.0	1.19 H	249	33.00	18.00

ANTENNA POLARITY & TEST DISTANCE: VERTICAL AT 3 M

NO.	FREQ. (MHz)	EMISSION LEVEL (dBuV/m)	LIMIT (dBuV/m)	MARGIN (dB)	ANTENNA HEIGHT (m)	TABLE ANGLE (Degree)	RAW VALUE (dBuV)	CORRECTION FACTOR (dB/m)
1	*5240.00	111.7 PK			1.00 V	276	72.10	39.60
2	*5240.00	102.1 AV			1.00 V	276	62.50	39.60
3	5350.00	57.3 PK	74.0	-16.7	1.10 V	272	50.90	6.40
4	5350.00	45.0 AV	54.0	-9.0	1.10 V	272	38.60	6.40
5	#10480.00	68.5 PK	74.0	-5.5	1.04 V	234	50.50	18.00
6	#10480.00	53.5 AV	54.0	-0.5	1.04 V	234	35.50	18.00

Remarks:

1. Emission Level(dBuV/m) = Raw Value(dBuV) + Correction Factor(dB/m)
2. Correction Factor(dB/m) = Antenna Factor(dB/m) + Cable Factor(dB)
3. The other emission levels were very low against the limit.
4. Margin value = Emission Level – Limit value
5. " * ": Fundamental frequency.
6. " # ": The radiated frequency is out of the restricted band.

CHANNEL	TX Channel 149	DETECTOR FUNCTION	Peak (PK)
FREQUENCY RANGE	1GHz ~ 40GHz		Average (AV)

ANTENNA POLARITY & TEST DISTANCE: HORIZONTAL AT 3 M

NO.	FREQ. (MHz)	EMISSION LEVEL (dBuV/m)	LIMIT (dBuV/m)	MARGIN (dB)	ANTENNA HEIGHT (m)	TABLE ANGLE (Degree)	RAW VALUE (dBuV)	CORRECTION FACTOR (dB/m)
1	#5714.90	57.9 PK	74.0	-16.1	2.67 H	248	50.70	7.20
2	#5714.90	45.2 AV	54.0	-8.8	2.67 H	248	38.00	7.20
3	#5722.90	73.7 PK	78.2	-4.5	2.73 H	247	66.50	7.20
4	#5725.00	60.5 PK	78.2	-17.7	2.92 H	246	53.30	7.20
5	*5745.00	108.6 PK			2.49 H	248	68.20	40.40
6	*5745.00	98.4 AV			2.49 H	248	58.00	40.40
7	11490.00	61.9 PK	74.0	-12.1	1.11 H	275	43.60	18.30
8	11490.00	49.7 AV	54.0	-4.3	1.11 H	275	31.40	18.30

ANTENNA POLARITY & TEST DISTANCE: VERTICAL AT 3 M

NO.	FREQ. (MHz)	EMISSION LEVEL (dBuV/m)	LIMIT (dBuV/m)	MARGIN (dB)	ANTENNA HEIGHT (m)	TABLE ANGLE (Degree)	RAW VALUE (dBuV)	CORRECTION FACTOR (dB/m)
1	#5714.90	59.2 PK	74.0	-14.8	1.08 V	276	52.00	7.20
2	#5714.90	46.4 AV	54.0	-7.6	1.08 V	276	39.20	7.20
3	#5722.90	77.0 PK	78.2	-1.2	1.01 V	263	69.80	7.20
4	#5725.00	64.0 PK	78.2	-14.2	1.10 V	261	56.80	7.20
5	*5745.00	112.5 PK			1.00 V	270	72.10	40.40
6	*5745.00	101.8 AV			1.00 V	270	61.40	40.40
7	11490.00	65.2 PK	74.0	-8.8	1.12 V	239	46.90	18.30
8	11490.00	53.4 AV	54.0	-0.6	1.12 V	239	35.10	18.30

Remarks:

1. Emission Level(dBuV/m) = Raw Value(dBuV) + Correction Factor(dB/m)
2. Correction Factor(dB/m) = Antenna Factor(dB/m) + Cable Factor(dB)
3. The other emission levels were very low against the limit.
4. Margin value = Emission Level – Limit value
5. " * ": Fundamental frequency.
6. " # ": The radiated frequency is out of the restricted band.

CHANNEL	TX Channel 157	DETECTOR FUNCTION	Peak (PK)
FREQUENCY RANGE	1GHz ~ 40GHz		Average (AV)

ANTENNA POLARITY & TEST DISTANCE: HORIZONTAL AT 3 M

NO.	FREQ. (MHz)	EMISSION LEVEL (dBuV/m)	LIMIT (dBuV/m)	MARGIN (dB)	ANTENNA HEIGHT (m)	TABLE ANGLE (Degree)	RAW VALUE (dBuV)	CORRECTION FACTOR (dB/m)
1	*5785.00	107.6 PK			2.60 H	253	67.10	40.50
2	*5785.00	97.5 AV			2.60 H	253	57.00	40.50
3	11570.00	63.7 PK	74.0	-10.3	1.00 H	269	45.50	18.20
4	11570.00	49.9 AV	54.0	-4.1	1.00 H	269	31.70	18.20

ANTENNA POLARITY & TEST DISTANCE: VERTICAL AT 3 M

NO.	FREQ. (MHz)	EMISSION LEVEL (dBuV/m)	LIMIT (dBuV/m)	MARGIN (dB)	ANTENNA HEIGHT (m)	TABLE ANGLE (Degree)	RAW VALUE (dBuV)	CORRECTION FACTOR (dB/m)
1	*5785.00	111.0 PK			1.00 V	245	70.50	40.50
2	*5785.00	101.4 AV			1.00 V	245	60.90	40.50
3	11570.00	67.2 PK	74.0	-6.8	1.00 V	235	49.00	18.20
4	11570.00	53.8 AV	54.0	-0.2	1.00 V	235	35.60	18.20

Remarks:

1. Emission Level(dBuV/m) = Raw Value(dBuV) + Correction Factor(dB/m)
2. Correction Factor(dB/m) = Antenna Factor(dB/m) + Cable Factor(dB)
3. The other emission levels were very low against the limit.
4. Margin value = Emission Level – Limit value
5. " * " : Fundamental frequency.

CHANNEL	TX Channel 165	DETECTOR FUNCTION	Peak (PK)
FREQUENCY RANGE	1GHz ~ 40GHz		Average (AV)

ANTENNA POLARITY & TEST DISTANCE: HORIZONTAL AT 3 M								
NO.	FREQ. (MHz)	EMISSION LEVEL (dBuV/m)	LIMIT (dBuV/m)	MARGIN (dB)	ANTENNA HEIGHT (m)	TABLE ANGLE (Degree)	RAW VALUE (dBuV)	CORRECTION FACTOR (dB/m)
1	*5825.00	107.3 PK			2.72 H	254	66.80	40.50
2	*5825.00	97.2 AV			2.72 H	254	56.70	40.50
3	#5850.00	50.5 PK	78.2	-27.7	2.68 H	239	43.00	7.50
4	#5852.10	63.2 PK	78.2	-15.0	2.67 H	238	55.60	7.60
5	#5860.10	60.6 PK	74.0	-13.4	2.78 H	244	53.00	7.60
6	#5860.10	46.4 AV	54.0	-7.6	2.78 H	244	38.80	7.60
7	11650.00	62.9 PK	74.0	-11.1	1.16 H	271	44.20	18.70
8	11650.00	50.3 AV	54.0	-3.7	1.16 H	271	31.60	18.70

ANTENNA POLARITY & TEST DISTANCE: VERTICAL AT 3 M								
NO.	FREQ. (MHz)	EMISSION LEVEL (dBuV/m)	LIMIT (dBuV/m)	MARGIN (dB)	ANTENNA HEIGHT (m)	TABLE ANGLE (Degree)	RAW VALUE (dBuV)	CORRECTION FACTOR (dB/m)
1	*5825.00	110.2 PK			1.00 V	242	69.70	40.50
2	*5825.00	100.4 AV			1.00 V	242	59.90	40.50
3	#5850.00	53.0 PK	78.2	-25.2	1.01 V	280	45.50	7.50
4	#5852.10	67.0 PK	78.2	-11.2	1.34 V	270	59.40	7.60
5	#5860.10	63.1 PK	74.0	-10.9	1.20 V	267	55.50	7.60
6	#5860.10	47.6 AV	54.0	-6.4	1.20 V	267	40.00	7.60
7	11650.00	66.5 PK	74.0	-7.5	1.01 V	236	47.80	18.70
8	11650.00	53.9 AV	54.0	-0.1	1.01 V	236	35.20	18.70

Remarks:

1. Emission Level(dBuV/m) = Raw Value(dBuV) + Correction Factor(dB/m)
2. Correction Factor(dB/m) = Antenna Factor(dB/m) + Cable Factor(dB)
3. The other emission levels were very low against the limit.
4. Margin value = Emission Level – Limit value
5. " * ": Fundamental frequency.
6. " # ": The radiated frequency is out of the restricted band.

802.11n (20MHz)

CHANNEL	TX Channel 36	DETECTOR FUNCTION	Peak (PK)
FREQUENCY RANGE	1GHz ~ 40GHz		Average (AV)

ANTENNA POLARITY & TEST DISTANCE: HORIZONTAL AT 3 M

NO.	FREQ. (MHz)	EMISSION LEVEL (dBuV/m)	LIMIT (dBuV/m)	MARGIN (dB)	ANTENNA HEIGHT (m)	TABLE ANGLE (Degree)	RAW VALUE (dBuV)	CORRECTION FACTOR (dB/m)
1	5150.00	68.3 PK	74.0	-5.7	1.08 H	258	62.10	6.20
2	5150.00	52.1 AV	54.0	-1.9	1.08 H	258	45.90	6.20
3	*5180.00	111.8 PK			1.03 H	260	72.30	39.50
4	*5180.00	101.9 AV			1.03 H	260	62.40	39.50
5	#10360.00	65.7 PK	74.0	-8.3	1.04 H	251	48.70	17.00
6	#10360.00	51.1 AV	54.0	-2.9	1.04 H	251	34.10	17.00

ANTENNA POLARITY & TEST DISTANCE: VERTICAL AT 3 M

NO.	FREQ. (MHz)	EMISSION LEVEL (dBuV/m)	LIMIT (dBuV/m)	MARGIN (dB)	ANTENNA HEIGHT (m)	TABLE ANGLE (Degree)	RAW VALUE (dBuV)	CORRECTION FACTOR (dB/m)
1	5150.00	67.6 PK	74.0	-6.4	1.02 V	240	61.40	6.20
2	5150.00	52.4 AV	54.0	-1.6	1.02 V	240	46.20	6.20
3	*5180.00	114.7 PK			1.02 V	257	75.20	39.50
4	*5180.00	103.7 AV			1.02 V	257	64.20	39.50
5	#10360.00	67.6 PK	74.0	-6.4	1.00 V	233	50.60	17.00
6	#10360.00	53.5 AV	54.0	-0.5	1.00 V	233	36.50	17.00

Remarks:

1. Emission Level(dBuV/m) = Raw Value(dBuV) + Correction Factor(dB/m)
2. Correction Factor(dB/m) = Antenna Factor(dB/m) + Cable Factor(dB)
3. The other emission levels were very low against the limit.
4. Margin value = Emission Level – Limit value
5. " * ": Fundamental frequency.
6. " # ": The radiated frequency is out of the restricted band.

CHANNEL	TX Channel 40	DETECTOR FUNCTION	Peak (PK)
FREQUENCY RANGE	1GHz ~ 40GHz		Average (AV)

ANTENNA POLARITY & TEST DISTANCE: HORIZONTAL AT 3 M

NO.	FREQ. (MHz)	EMISSION LEVEL (dBuV/m)	LIMIT (dBuV/m)	MARGIN (dB)	ANTENNA HEIGHT (m)	TABLE ANGLE (Degree)	RAW VALUE (dBuV)	CORRECTION FACTOR (dB/m)
1	*5200.00	110.4 PK			1.00 H	225	70.80	39.60
2	*5200.00	101.0 AV			1.00 H	225	61.40	39.60
3	#10400.00	63.3 PK	74.0	-10.7	2.87 H	248	46.30	17.00
4	#10400.00	50.5 AV	54.0	-3.5	2.87 H	248	33.50	17.00

ANTENNA POLARITY & TEST DISTANCE: VERTICAL AT 3 M

NO.	FREQ. (MHz)	EMISSION LEVEL (dBuV/m)	LIMIT (dBuV/m)	MARGIN (dB)	ANTENNA HEIGHT (m)	TABLE ANGLE (Degree)	RAW VALUE (dBuV)	CORRECTION FACTOR (dB/m)
1	*5200.00	113.3 PK			1.28 V	255	73.70	39.60
2	*5200.00	103.3 AV			1.28 V	255	63.70	39.60
3	#10400.00	67.5 PK	74.0	-6.5	1.00 V	232	50.50	17.00
4	#10400.00	53.4 AV	54.0	-0.6	1.00 V	232	36.40	17.00

Remarks:

1. Emission Level(dBuV/m) = Raw Value(dBuV) + Correction Factor(dB/m)
2. Correction Factor(dB/m) = Antenna Factor(dB/m) + Cable Factor(dB)
3. The other emission levels were very low against the limit.
4. Margin value = Emission Level – Limit value
5. " * ": Fundamental frequency.
6. " # ": The radiated frequency is out of the restricted band.

CHANNEL	TX Channel 48	DETECTOR FUNCTION	Peak (PK)
FREQUENCY RANGE	1GHz ~ 40GHz		Average (AV)

ANTENNA POLARITY & TEST DISTANCE: HORIZONTAL AT 3 M

NO.	FREQ. (MHz)	EMISSION LEVEL (dBuV/m)	LIMIT (dBuV/m)	MARGIN (dB)	ANTENNA HEIGHT (m)	TABLE ANGLE (Degree)	RAW VALUE (dBuV)	CORRECTION FACTOR (dB/m)
1	*5240.00	110.6 PK			1.08 H	259	71.00	39.60
2	*5240.00	100.2 AV			1.08 H	259	60.60	39.60
3	5350.00	57.2 PK	74.0	-16.8	1.17 H	253	50.80	6.40
4	5350.00	44.9 AV	54.0	-9.1	1.17 H	253	38.50	6.40
5	#10480.00	63.1 PK	74.0	-10.9	1.17 H	250	45.10	18.00
6	#10480.00	50.6 AV	54.0	-3.4	1.17 H	250	32.60	18.00

ANTENNA POLARITY & TEST DISTANCE: VERTICAL AT 3 M

NO.	FREQ. (MHz)	EMISSION LEVEL (dBuV/m)	LIMIT (dBuV/m)	MARGIN (dB)	ANTENNA HEIGHT (m)	TABLE ANGLE (Degree)	RAW VALUE (dBuV)	CORRECTION FACTOR (dB/m)
1	*5240.00	113.0 PK			1.12 V	244	73.40	39.60
2	*5240.00	103.0 AV			1.12 V	244	63.40	39.60
3	5350.00	57.7 PK	74.0	-16.3	1.21 V	250	51.30	6.40
4	5350.00	45.1 AV	54.0	-8.9	1.21 V	250	38.70	6.40
5	#10480.00	67.3 PK	74.0	-6.7	1.00 V	234	49.30	18.00
6	#10480.00	53.3 AV	54.0	-0.7	1.00 V	234	35.30	18.00

Remarks:

1. Emission Level(dBuV/m) = Raw Value(dBuV) + Correction Factor(dB/m)
2. Correction Factor(dB/m) = Antenna Factor(dB/m) + Cable Factor(dB)
3. The other emission levels were very low against the limit.
4. Margin value = Emission Level – Limit value
5. " * ": Fundamental frequency.
6. " # ": The radiated frequency is out of the restricted band.

CHANNEL	TX Channel 149	DETECTOR FUNCTION	Peak (PK)
FREQUENCY RANGE	1GHz ~ 40GHz		Average (AV)

ANTENNA POLARITY & TEST DISTANCE: HORIZONTAL AT 3 M								
NO.	FREQ. (MHz)	EMISSION LEVEL (dBuV/m)	LIMIT (dBuV/m)	MARGIN (dB)	ANTENNA HEIGHT (m)	TABLE ANGLE (Degree)	RAW VALUE (dBuV)	CORRECTION FACTOR (dB/m)
1	#5714.90	59.2 PK	74.0	-14.8	1.07 H	199	52.00	7.20
2	#5714.90	46.2 AV	54.0	-7.8	1.07 H	199	39.00	7.20
3	#5722.90	69.2 PK	78.2	-9.0	1.00 H	208	62.00	7.20
4	#5725.00	59.2 PK	78.2	-19.0	1.02 H	212	52.00	7.20
5	*5745.00	110.9 PK			1.00 H	203	70.50	40.40
6	*5745.00	101.4 AV			1.00 H	203	61.00	40.40
7	11490.00	62.5 PK	74.0	-11.5	1.14 H	272	44.20	18.30
8	11490.00	49.7 AV	54.0	-4.3	1.14 H	272	31.40	18.30

ANTENNA POLARITY & TEST DISTANCE: VERTICAL AT 3 M								
NO.	FREQ. (MHz)	EMISSION LEVEL (dBuV/m)	LIMIT (dBuV/m)	MARGIN (dB)	ANTENNA HEIGHT (m)	TABLE ANGLE (Degree)	RAW VALUE (dBuV)	CORRECTION FACTOR (dB/m)
1	#5714.90	62.4 PK	74.0	-11.6	1.09 V	270	55.20	7.20
2	#5714.90	46.7 AV	54.0	-7.3	1.09 V	270	39.50	7.20
3	#5722.90	77.8 PK	78.2	-0.4	1.20 V	261	70.60	7.20
4	#5725.00	64.4 PK	78.2	-13.8	1.11 V	270	57.20	7.20
5	*5745.00	111.8 PK			1.00 V	258	71.40	40.40
6	*5745.00	101.8 AV			1.00 V	258	61.40	40.40
7	11490.00	65.9 PK	74.0	-8.1	1.21 V	237	47.60	18.30
8	11490.00	52.6 AV	54.0	-1.4	1.21 V	237	34.30	18.30

Remarks:

1. Emission Level(dBuV/m) = Raw Value(dBuV) + Correction Factor(dB/m)
2. Correction Factor(dB/m) = Antenna Factor(dB/m) + Cable Factor(dB)
3. The other emission levels were very low against the limit.
4. Margin value = Emission Level – Limit value
5. " * ": Fundamental frequency.
6. " # ": The radiated frequency is out of the restricted band.

CHANNEL	TX Channel 157	DETECTOR FUNCTION	Peak (PK)
FREQUENCY RANGE	1GHz ~ 40GHz		Average (AV)

ANTENNA POLARITY & TEST DISTANCE: HORIZONTAL AT 3 M								
NO.	FREQ. (MHz)	EMISSION LEVEL (dBuV/m)	LIMIT (dBuV/m)	MARGIN (dB)	ANTENNA HEIGHT (m)	TABLE ANGLE (Degree)	RAW VALUE (dBuV)	CORRECTION FACTOR (dB/m)
1	*5785.00	110.2 PK			1.00 H	203	69.70	40.50
2	*5785.00	100.5 AV			1.00 H	203	60.00	40.50
3	11570.00	61.4 PK	74.0	-12.6	1.11 H	271	43.20	18.20
4	11570.00	49.7 AV	54.0	-4.3	1.11 H	271	31.50	18.20
ANTENNA POLARITY & TEST DISTANCE: VERTICAL AT 3 M								
NO.	FREQ. (MHz)	EMISSION LEVEL (dBuV/m)	LIMIT (dBuV/m)	MARGIN (dB)	ANTENNA HEIGHT (m)	TABLE ANGLE (Degree)	RAW VALUE (dBuV)	CORRECTION FACTOR (dB/m)
1	*5785.00	111.7 PK			1.00 V	259	71.20	40.50
2	*5785.00	102.1 AV			1.00 V	259	61.60	40.50
3	11570.00	67.1 PK	74.0	-6.9	1.07 V	233	48.90	18.20
4	11570.00	53.4 AV	54.0	-0.6	1.07 V	233	35.20	18.20

Remarks:

1. Emission Level(dBuV/m) = Raw Value(dBuV) + Correction Factor(dB/m)
2. Correction Factor(dB/m) = Antenna Factor(dB/m) + Cable Factor(dB)
3. The other emission levels were very low against the limit.
4. Margin value = Emission Level – Limit value
5. " * ": Fundamental frequency.
6. " # ": The radiated frequency is out of the restricted band.

CHANNEL	TX Channel 165	DETECTOR FUNCTION	Peak (PK)
FREQUENCY RANGE	1GHz ~ 40GHz		Average (AV)

ANTENNA POLARITY & TEST DISTANCE: HORIZONTAL AT 3 M								
NO.	FREQ. (MHz)	EMISSION LEVEL (dBuV/m)	LIMIT (dBuV/m)	MARGIN (dB)	ANTENNA HEIGHT (m)	TABLE ANGLE (Degree)	RAW VALUE (dBuV)	CORRECTION FACTOR (dB/m)
1	*5825.00	109.4 PK			1.00 H	202	68.90	40.50
2	*5825.00	99.5 AV			1.00 H	202	59.00	40.50
3	#5850.00	49.6 PK	78.2	-28.6	1.12 H	203	42.10	7.50
4	#5852.10	60.9 PK	78.2	-17.3	1.05 H	201	53.30	7.60
5	#5860.10	58.8 PK	74.0	-15.2	1.15 H	199	51.20	7.60
6	#5860.10	46.0 AV	54.0	-8.0	1.15 H	199	38.40	7.60
7	11650.00	63.1 PK	74.0	-10.9	1.05 H	271	44.40	18.70
8	11650.00	49.6 AV	54.0	-4.4	1.05 H	271	30.90	18.70

ANTENNA POLARITY & TEST DISTANCE: VERTICAL AT 3 M								
NO.	FREQ. (MHz)	EMISSION LEVEL (dBuV/m)	LIMIT (dBuV/m)	MARGIN (dB)	ANTENNA HEIGHT (m)	TABLE ANGLE (Degree)	RAW VALUE (dBuV)	CORRECTION FACTOR (dB/m)
1	*5825.00	110.7 PK			1.00 V	258	70.20	40.50
2	*5825.00	100.5 AV			1.00 V	258	60.00	40.50
3	#5850.00	55.0 PK	78.2	-23.2	1.01 V	276	47.50	7.50
4	#5852.10	66.5 PK	78.2	-11.7	1.10 V	276	58.90	7.60
5	#5860.10	60.1 PK	74.0	-13.9	1.04 V	270	52.50	7.60
6	#5860.10	47.0 AV	54.0	-7.0	1.04 V	270	39.40	7.60
7	11650.00	66.3 PK	74.0	-7.7	1.13 V	235	47.60	18.70
8	11650.00	53.5 AV	54.0	-0.5	1.13 V	235	34.80	18.70

Remarks:

1. Emission Level(dBuV/m) = Raw Value(dBuV) + Correction Factor(dB/m)
2. Correction Factor(dB/m) = Antenna Factor(dB/m) + Cable Factor(dB)
3. The other emission levels were very low against the limit.
4. Margin value = Emission Level – Limit value
5. " * ": Fundamental frequency.
6. " # ": The radiated frequency is out of the restricted band.

802.11n (40MHz)

CHANNEL	TX Channel 38	DETECTOR FUNCTION	Peak (PK)
FREQUENCY RANGE	1GHz ~ 40GHz		Average (AV)

ANTENNA POLARITY & TEST DISTANCE: HORIZONTAL AT 3 M

NO.	FREQ. (MHz)	EMISSION LEVEL (dBuV/m)	LIMIT (dBuV/m)	MARGIN (dB)	ANTENNA HEIGHT (m)	TABLE ANGLE (Degree)	RAW VALUE (dBuV)	CORRECTION FACTOR (dB/m)
1	5150.00	62.8 PK	74.0	-11.2	1.14 H	221	56.60	6.20
2	5150.00	49.3 AV	54.0	-4.7	1.14 H	221	43.10	6.20
3	*5190.00	105.6 PK			1.03 H	224	66.10	39.50
4	*5190.00	95.7 AV			1.03 H	224	56.20	39.50
5	#10380.00	58.9 PK	74.0	-15.1	1.24 H	155	41.90	17.00
6	#10380.00	46.4 AV	54.0	-7.6	1.24 H	155	29.40	17.00

ANTENNA POLARITY & TEST DISTANCE: VERTICAL AT 3 M

NO.	FREQ. (MHz)	EMISSION LEVEL (dBuV/m)	LIMIT (dBuV/m)	MARGIN (dB)	ANTENNA HEIGHT (m)	TABLE ANGLE (Degree)	RAW VALUE (dBuV)	CORRECTION FACTOR (dB/m)
1	5150.00	66.5 PK	74.0	-7.5	1.02 V	269	60.30	6.20
2	5150.00	53.6 AV	54.0	-0.4	1.02 V	269	47.40	6.20
3	*5190.00	108.2 PK			1.28 V	258	68.70	39.50
4	*5190.00	98.0 AV			1.28 V	258	58.50	39.50
5	#10380.00	63.5 PK	74.0	-10.5	1.00 V	238	46.50	17.00
6	#10380.00	50.9 AV	54.0	-3.1	1.00 V	238	33.90	17.00

Remarks:

1. Emission Level(dBuV/m) = Raw Value(dBuV) + Correction Factor(dB/m)
2. Correction Factor(dB/m) = Antenna Factor(dB/m) + Cable Factor(dB)
3. The other emission levels were very low against the limit.
4. Margin value = Emission Level – Limit value
5. " * ": Fundamental frequency.
6. " # ": The radiated frequency is out of the restricted band.

CHANNEL	TX Channel 46	DETECTOR FUNCTION	Peak (PK)
FREQUENCY RANGE	1GHz ~ 40GHz		Average (AV)

ANTENNA POLARITY & TEST DISTANCE: HORIZONTAL AT 3 M

NO.	FREQ. (MHz)	EMISSION LEVEL (dBuV/m)	LIMIT (dBuV/m)	MARGIN (dB)	ANTENNA HEIGHT (m)	TABLE ANGLE (Degree)	RAW VALUE (dBuV)	CORRECTION FACTOR (dB/m)
1	5150.00	56.7 PK	74.0	-17.3	1.17 H	261	50.50	6.20
2	5150.00	44.7 AV	54.0	-9.3	1.17 H	261	38.50	6.20
3	*5230.00	108.1 PK			1.00 H	260	68.50	39.60
4	*5230.00	98.8 AV			1.00 H	260	59.20	39.60
5	#10460.00	63.4 PK	74.0	-10.6	1.10 H	251	45.60	17.80
6	#10460.00	51.3 AV	54.0	-2.7	1.10 H	251	33.50	17.80

ANTENNA POLARITY & TEST DISTANCE: VERTICAL AT 3 M

NO.	FREQ. (MHz)	EMISSION LEVEL (dBuV/m)	LIMIT (dBuV/m)	MARGIN (dB)	ANTENNA HEIGHT (m)	TABLE ANGLE (Degree)	RAW VALUE (dBuV)	CORRECTION FACTOR (dB/m)
1	5150.00	58.4 PK	74.0	-15.6	1.21 V	260	52.20	6.20
2	5150.00	46.5 AV	54.0	-7.5	1.21 V	260	40.30	6.20
3	*5230.00	112.6 PK			1.14 V	258	73.00	39.60
4	*5230.00	102.5 AV			1.14 V	258	62.90	39.60
5	#10460.00	68.7 PK	74.0	-5.3	1.00 V	233	50.90	17.80
6	#10460.00	53.8 AV	54.0	-0.2	1.00 V	233	36.00	17.80

Remarks:

1. Emission Level(dBuV/m) = Raw Value(dBuV) + Correction Factor(dB/m)
2. Correction Factor(dB/m) = Antenna Factor(dB/m) + Cable Factor(dB)
3. The other emission levels were very low against the limit.
4. Margin value = Emission Level – Limit value
5. " * ": Fundamental frequency.
6. " # ": The radiated frequency is out of the restricted band.

CHANNEL	TX Channel 151	DETECTOR FUNCTION	Peak (PK)
FREQUENCY RANGE	1GHz ~ 40GHz		Average (AV)

ANTENNA POLARITY & TEST DISTANCE: HORIZONTAL AT 3 M								
NO.	FREQ. (MHz)	EMISSION LEVEL (dBuV/m)	LIMIT (dBuV/m)	MARGIN (dB)	ANTENNA HEIGHT (m)	TABLE ANGLE (Degree)	RAW VALUE (dBuV)	CORRECTION FACTOR (dB/m)
1	#5714.90	61.2 PK	74.0	-12.8	1.00 H	205	54.00	7.20
2	#5714.90	49.0 AV	54.0	-5.0	1.00 H	205	41.80	7.20
3	#5722.90	69.1 PK	78.2	-9.1	1.07 H	204	61.90	7.20
4	#5725.00	55.8 PK	78.2	-22.4	1.21 H	202	48.60	7.20
5	*5755.00	103.7 PK			1.00 H	198	63.20	40.50
6	*5755.00	94.8 AV			1.00 H	198	54.30	40.50
7	11510.00	59.7 PK	74.0	-14.3	1.06 H	209	41.50	18.20
8	11510.00	47.9 AV	54.0	-6.1	1.06 H	209	29.70	18.20

ANTENNA POLARITY & TEST DISTANCE: VERTICAL AT 3 M								
NO.	FREQ. (MHz)	EMISSION LEVEL (dBuV/m)	LIMIT (dBuV/m)	MARGIN (dB)	ANTENNA HEIGHT (m)	TABLE ANGLE (Degree)	RAW VALUE (dBuV)	CORRECTION FACTOR (dB/m)
1	#5714.90	68.0 PK	74.0	-6.0	1.00 V	261	60.80	7.20
2	#5714.90	53.8 AV	54.0	-0.2	1.00 V	261	46.60	7.20
3	#5722.90	73.4 PK	78.2	-4.8	1.00 V	259	66.20	7.20
4	#5725.00	59.5 PK	78.2	-18.7	1.21 V	260	52.30	7.20
5	*5755.00	105.9 PK			1.02 V	256	65.40	40.50
6	*5755.00	96.7 AV			1.02 V	256	56.20	40.50
7	11510.00	60.9 PK	74.0	-13.1	1.34 V	221	42.70	18.20
8	11510.00	49.0 AV	54.0	-5.0	1.34 V	221	30.80	18.20

Remarks:

1. Emission Level(dBuV/m) = Raw Value(dBuV) + Correction Factor(dB/m)
2. Correction Factor(dB/m) = Antenna Factor(dB/m) + Cable Factor(dB)
3. The other emission levels were very low against the limit.
4. Margin value = Emission Level – Limit value
5. " * ": Fundamental frequency.
6. " # ": The radiated frequency is out of the restricted band.

CHANNEL	TX Channel 159	DETECTOR FUNCTION	Peak (PK)
FREQUENCY RANGE	1GHz ~ 40GHz		Average (AV)

ANTENNA POLARITY & TEST DISTANCE: HORIZONTAL AT 3 M

NO.	FREQ. (MHz)	EMISSION LEVEL (dBuV/m)	LIMIT (dBuV/m)	MARGIN (dB)	ANTENNA HEIGHT (m)	TABLE ANGLE (Degree)	RAW VALUE (dBuV)	CORRECTION FACTOR (dB/m)
1	*5795.00	108.7 PK			1.00 H	204	68.20	40.50
2	*5795.00	99.1 AV			1.00 H	204	58.60	40.50
3	#5850.00	48.5 PK	78.2	-29.7	1.00 H	193	41.00	7.50
4	#5852.10	61.2 PK	78.2	-17.0	1.09 H	195	53.60	7.60
5	#5860.10	59.1 PK	74.0	-14.9	1.20 H	214	51.50	7.60
6	#5860.10	46.8 AV	54.0	-7.2	1.20 H	214	39.20	7.60
7	11590.00	61.3 PK	74.0	-12.7	1.18 H	244	43.00	18.30
8	11590.00	50.0 AV	54.0	-4.0	1.18 H	244	31.70	18.30

ANTENNA POLARITY & TEST DISTANCE: VERTICAL AT 3 M

NO.	FREQ. (MHz)	EMISSION LEVEL (dBuV/m)	LIMIT (dBuV/m)	MARGIN (dB)	ANTENNA HEIGHT (m)	TABLE ANGLE (Degree)	RAW VALUE (dBuV)	CORRECTION FACTOR (dB/m)
1	*5795.00	110.3 PK			1.01 V	258	69.80	40.50
2	*5795.00	101.0 AV			1.01 V	258	60.50	40.50
3	#5850.00	53.7 PK	78.2	-24.5	1.00 V	277	46.20	7.50
4	#5852.10	65.7 PK	78.2	-12.5	1.02 V	273	58.10	7.60
5	#5860.10	62.6 PK	74.0	-11.4	1.16 V	278	55.00	7.60
6	#5860.10	49.7 AV	54.0	-4.3	1.16 V	278	42.10	7.60
7	11590.00	66.6 PK	74.0	-7.4	1.11 V	235	48.30	18.30
8	11590.00	53.7 AV	54.0	-0.3	1.11 V	235	35.40	18.30

Remarks:

1. Emission Level(dBuV/m) = Raw Value(dBuV) + Correction Factor(dB/m)
2. Correction Factor(dB/m) = Antenna Factor(dB/m) + Cable Factor(dB)
3. The other emission levels were very low against the limit.
4. Margin value = Emission Level – Limit value
5. " * ": Fundamental frequency.
6. " # ": The radiated frequency is out of the restricted band.

802.11ac (20MHz)

CHANNEL	TX Channel 36	DETECTOR	Peak (PK)
FREQUENCY RANGE	1GHz ~ 40GHz	FUNCTION	Average (AV)

ANTENNA POLARITY & TEST DISTANCE: HORIZONTAL AT 3 M								
NO.	FREQ. (MHz)	EMISSION LEVEL (dBuV/m)	LIMIT (dBuV/m)	MARGIN (dB)	ANTENNA HEIGHT (m)	TABLE ANGLE (Degree)	RAW VALUE (dBuV)	CORRECTION FACTOR (dB/m)
1	5150.00	68.0 PK	74.0	-6.0	1.06 H	252	59.70	8.30
2	5150.00	51.7 AV	54.0	-2.3	1.06 H	252	43.40	8.30
3	*5180.00	110.5 PK			1.06 H	238	68.90	41.60
4	*5180.00	100.3 AV			1.06 H	238	58.70	41.60
5	#10360.00	65.1 PK	74.0	-8.9	1.03 H	264	49.30	15.80
6	#10360.00	50.4 AV	54.0	-3.6	1.03 H	264	34.60	15.80

ANTENNA POLARITY & TEST DISTANCE: VERTICAL AT 3 M								
NO.	FREQ. (MHz)	EMISSION LEVEL (dBuV/m)	LIMIT (dBuV/m)	MARGIN (dB)	ANTENNA HEIGHT (m)	TABLE ANGLE (Degree)	RAW VALUE (dBuV)	CORRECTION FACTOR (dB/m)
1	5150.00	67.3 PK	74.0	-6.7	1.04 V	228	59.00	8.30
2	5150.00	52.0 AV	54.0	-2.0	1.04 V	228	43.70	8.30
3	*5180.00	113.5 PK			1.06 V	237	71.90	41.60
4	*5180.00	102.3 AV			1.06 V	237	60.70	41.60
5	#10360.00	67.2 PK	74.0	-6.8	1.00 V	234	51.40	15.80
6	#10360.00	53.1 AV	54.0	-0.9	1.00 V	234	37.30	15.80

Remarks:

1. Emission Level(dBuV/m) = Raw Value(dBuV) + Correction Factor(dB/m)
2. Correction Factor(dB/m) = Antenna Factor(dB/m) + Cable Factor(dB)
3. The other emission levels were very low against the limit.
4. Margin value = Emission Level – Limit value
5. " * ": Fundamental frequency.
6. " # ": The radiated frequency is out of the restricted band.

CHANNEL	TX Channel 40	DETECTOR FUNCTION	Peak (PK)
FREQUENCY RANGE	1GHz ~ 40GHz		Average (AV)

ANTENNA POLARITY & TEST DISTANCE: HORIZONTAL AT 3 M								
NO.	FREQ. (MHz)	EMISSION LEVEL (dBuV/m)	LIMIT (dBuV/m)	MARGIN (dB)	ANTENNA HEIGHT (m)	TABLE ANGLE (Degree)	RAW VALUE (dBuV)	CORRECTION FACTOR (dB/m)
1	*5200.00	109.1 PK			1.02 H	203	67.30	41.80
2	*5200.00	99.7 AV			1.02 H	203	57.90	41.80
3	#10400.00	63.0 PK	74.0	-11.0	2.55 H	239	47.30	15.70
4	#10400.00	50.1 AV	54.0	-3.9	2.55 H	239	34.40	15.70
ANTENNA POLARITY & TEST DISTANCE: VERTICAL AT 3 M								
NO.	FREQ. (MHz)	EMISSION LEVEL (dBuV/m)	LIMIT (dBuV/m)	MARGIN (dB)	ANTENNA HEIGHT (m)	TABLE ANGLE (Degree)	RAW VALUE (dBuV)	CORRECTION FACTOR (dB/m)
1	*5200.00	112.2 PK			1.31 V	269	70.40	41.80
2	*5200.00	102.0 AV			1.31 V	269	60.20	41.80
3	#10400.00	67.1 PK	74.0	-6.9	1.00 V	241	51.40	15.70
4	#10400.00	53.1 AV	54.0	-0.9	1.00 V	241	37.40	15.70

Remarks:

1. Emission Level(dBuV/m) = Raw Value(dBuV) + Correction Factor(dB/m)
2. Correction Factor(dB/m) = Antenna Factor(dB/m) + Cable Factor(dB)
3. The other emission levels were very low against the limit.
4. Margin value = Emission Level – Limit value
5. " * ": Fundamental frequency.
6. " # ": The radiated frequency is out of the restricted band.

CHANNEL	TX Channel 48	DETECTOR FUNCTION	Peak (PK)
FREQUENCY RANGE	1GHz ~ 40GHz		Average (AV)

ANTENNA POLARITY & TEST DISTANCE: HORIZONTAL AT 3 M								
NO.	FREQ. (MHz)	EMISSION LEVEL (dBuV/m)	LIMIT (dBuV/m)	MARGIN (dB)	ANTENNA HEIGHT (m)	TABLE ANGLE (Degree)	RAW VALUE (dBuV)	CORRECTION FACTOR (dB/m)
1	*5240.00	109.6 PK			1.03 H	229	67.80	41.80
2	*5240.00	99.0 AV			1.03 H	229	57.20	41.80
3	5350.00	57.0 PK	74.0	-17.0	1.13 H	239	48.40	8.60
4	5350.00	44.5 AV	54.0	-9.5	1.13 H	239	35.90	8.60
5	#10480.00	62.9 PK	74.0	-11.1	1.52 H	239	46.30	16.60
6	#10480.00	50.4 AV	54.0	-3.6	1.52 H	239	33.80	16.60
ANTENNA POLARITY & TEST DISTANCE: VERTICAL AT 3 M								
NO.	FREQ. (MHz)	EMISSION LEVEL (dBuV/m)	LIMIT (dBuV/m)	MARGIN (dB)	ANTENNA HEIGHT (m)	TABLE ANGLE (Degree)	RAW VALUE (dBuV)	CORRECTION FACTOR (dB/m)
1	*5240.00	112.0 PK			1.10 V	264	70.20	41.80
2	*5240.00	101.8 AV			1.10 V	264	60.00	41.80
3	5350.00	57.5 PK	74.0	-16.5	1.16 V	238	48.90	8.60
4	5350.00	45.8 AV	54.0	-8.2	1.16 V	238	37.20	8.60
5	#10480.00	67.1 PK	74.0	-6.9	1.01 V	284	50.50	16.60
6	#10480.00	53.0 AV	54.0	-1.0	1.01 V	284	36.40	16.60

Remarks:

1. Emission Level(dBuV/m) = Raw Value(dBuV) + Correction Factor(dB/m)
2. Correction Factor(dB/m) = Antenna Factor(dB/m) + Cable Factor(dB)
3. The other emission levels were very low against the limit.
4. Margin value = Emission Level – Limit value
5. " * ": Fundamental frequency.
6. " # ": The radiated frequency is out of the restricted band.

CHANNEL	TX Channel 149	DETECTOR FUNCTION	Peak (PK)
FREQUENCY RANGE	1GHz ~ 40GHz		Average (AV)

ANTENNA POLARITY & TEST DISTANCE: HORIZONTAL AT 3 M

NO.	FREQ. (MHz)	EMISSION LEVEL (dBuV/m)	LIMIT (dBuV/m)	MARGIN (dB)	ANTENNA HEIGHT (m)	TABLE ANGLE (Degree)	RAW VALUE (dBuV)	CORRECTION FACTOR (dB/m)
1	#5714.90	59.0 PK	74.0	-15.0	1.03 H	185	49.40	9.60
2	#5714.90	45.8 AV	54.0	-8.2	1.03 H	185	36.20	9.60
3	#5722.90	68.7 PK	78.2	-9.5	1.01 H	231	59.10	9.60
4	#5725.00	58.5 PK	78.2	-19.7	1.05 H	186	48.90	9.60
5	*5745.00	110.0 PK			1.00 H	207	67.30	42.70
6	*5745.00	100.2 AV			1.00 H	207	57.50	42.70
7	11490.00	62.4 PK	74.0	-11.6	1.13 H	264	44.30	18.10
8	11490.00	49.5 AV	54.0	-4.5	1.13 H	264	31.40	18.10

ANTENNA POLARITY & TEST DISTANCE: VERTICAL AT 3 M

NO.	FREQ. (MHz)	EMISSION LEVEL (dBuV/m)	LIMIT (dBuV/m)	MARGIN (dB)	ANTENNA HEIGHT (m)	TABLE ANGLE (Degree)	RAW VALUE (dBuV)	CORRECTION FACTOR (dB/m)
1	#5714.90	62.1 PK	74.0	-11.9	1.06 V	235	52.50	9.60
2	#5714.90	46.1 AV	54.0	-7.9	1.06 V	235	36.50	9.60
3	#5722.90	77.5 PK	78.2	-0.7	1.18 V	238	67.90	9.60
4	#5725.00	64.1 PK	78.2	-14.1	1.06 V	253	54.50	9.60
5	*5745.00	110.7 PK			1.00 V	232	68.00	42.70
6	*5745.00	100.4 AV			1.00 V	232	57.70	42.70
7	11490.00	65.6 PK	74.0	-8.4	1.16 V	228	47.50	18.10
8	11490.00	52.1 AV	54.0	-1.9	1.16 V	228	34.00	18.10

Remarks:

1. Emission Level(dBuV/m) = Raw Value(dBuV) + Correction Factor(dB/m)
2. Correction Factor(dB/m) = Antenna Factor(dB/m) + Cable Factor(dB)
3. The other emission levels were very low against the limit.
4. Margin value = Emission Level – Limit value
5. " * ": Fundamental frequency.
6. " # ": The radiated frequency is out of the restricted band.

CHANNEL	TX Channel 157	DETECTOR FUNCTION	Peak (PK)
FREQUENCY RANGE	1GHz ~ 40GHz		Average (AV)

ANTENNA POLARITY & TEST DISTANCE: HORIZONTAL AT 3 M

NO.	FREQ. (MHz)	EMISSION LEVEL (dBuV/m)	LIMIT (dBuV/m)	MARGIN (dB)	ANTENNA HEIGHT (m)	TABLE ANGLE (Degree)	RAW VALUE (dBuV)	CORRECTION FACTOR (dB/m)
1	*5785.00	109.1 PK			1.00 H	198	66.30	42.80
2	*5785.00	99.1 AV			1.00 H	198	56.30	42.80
3	11570.00	64.1 PK	74.0	-9.9	1.05 H	253	45.90	18.20
4	11570.00	49.2 AV	54.0	-4.8	1.05 H	253	31.00	18.20

ANTENNA POLARITY & TEST DISTANCE: VERTICAL AT 3 M

NO.	FREQ. (MHz)	EMISSION LEVEL (dBuV/m)	LIMIT (dBuV/m)	MARGIN (dB)	ANTENNA HEIGHT (m)	TABLE ANGLE (Degree)	RAW VALUE (dBuV)	CORRECTION FACTOR (dB/m)
1	*5785.00	110.6 PK			1.00 V	235	67.80	42.80
2	*5785.00	100.8 AV			1.00 V	235	58.00	42.80
3	11570.00	67.0 PK	74.0	-7.0	1.07 V	241	48.80	18.20
4	11570.00	53.2 AV	54.0	-0.8	1.07 V	241	35.00	18.20

Remarks:

1. Emission Level(dBuV/m) = Raw Value(dBuV) + Correction Factor(dB/m)
2. Correction Factor(dB/m) = Antenna Factor(dB/m) + Cable Factor(dB)
3. The other emission levels were very low against the limit.
4. Margin value = Emission Level – Limit value
5. " * ": Fundamental frequency.
6. " # ": The radiated frequency is out of the restricted band.

CHANNEL	TX Channel 165	DETECTOR FUNCTION	Peak (PK)
FREQUENCY RANGE	1GHz ~ 40GHz		Average (AV)

ANTENNA POLARITY & TEST DISTANCE: HORIZONTAL AT 3 M								
NO.	FREQ. (MHz)	EMISSION LEVEL (dBuV/m)	LIMIT (dBuV/m)	MARGIN (dB)	ANTENNA HEIGHT (m)	TABLE ANGLE (Degree)	RAW VALUE (dBuV)	CORRECTION FACTOR (dB/m)
1	*5825.00	108.3 PK			1.00 H	211	65.40	42.90
2	*5825.00	98.1 AV			1.00 H	211	55.20	42.90
3	#5850.00	49.2 PK	78.2	-29.0	1.14 H	225	39.40	9.80
4	#5852.10	60.3 PK	78.2	-17.9	1.02 H	193	50.40	9.90
5	#5860.10	58.6 PK	74.0	-15.4	1.11 H	182	48.70	9.90
6	#5860.10	45.6 AV	54.0	-8.4	1.11 H	182	35.70	9.90
7	11650.00	62.8 PK	74.0	-11.2	1.02 H	253	44.00	18.80
8	11650.00	49.2 AV	54.0	-4.8	1.02 H	253	30.40	18.80

ANTENNA POLARITY & TEST DISTANCE: VERTICAL AT 3 M								
NO.	FREQ. (MHz)	EMISSION LEVEL (dBuV/m)	LIMIT (dBuV/m)	MARGIN (dB)	ANTENNA HEIGHT (m)	TABLE ANGLE (Degree)	RAW VALUE (dBuV)	CORRECTION FACTOR (dB/m)
1	*5825.00	109.7 PK			1.01 V	239	66.80	42.90
2	*5825.00	99.2 AV			1.01 V	239	56.30	42.90
3	#5850.00	54.6 PK	78.2	-23.6	1.00 V	253	44.80	9.80
4	#5852.10	66.0 PK	78.2	-12.2	1.06 V	269	56.10	9.90
5	#5860.10	59.8 PK	74.0	-14.2	1.03 V	242	49.90	9.90
6	#5860.10	46.5 AV	54.0	-7.5	1.03 V	242	36.60	9.90
7	11650.00	66.2 PK	74.0	-7.8	1.12 V	237	47.40	18.80
8	11650.00	53.3 AV	54.0	-0.7	1.12 V	237	34.50	18.80

Remarks:

1. Emission Level(dBuV/m) = Raw Value(dBuV) + Correction Factor(dB/m)
2. Correction Factor(dB/m) = Antenna Factor(dB/m) + Cable Factor(dB)
3. The other emission levels were very low against the limit.
4. Margin value = Emission Level – Limit value
5. " * ": Fundamental frequency.
6. " # ": The radiated frequency is out of the restricted band.

802.11ac (40MHz)

CHANNEL	TX Channel 38	DETECTOR FUNCTION	Peak (PK)
FREQUENCY RANGE	1GHz ~ 40GHz		Average (AV)

ANTENNA POLARITY & TEST DISTANCE: HORIZONTAL AT 3 M

NO.	FREQ. (MHz)	EMISSION LEVEL (dBuV/m)	LIMIT (dBuV/m)	MARGIN (dB)	ANTENNA HEIGHT (m)	TABLE ANGLE (Degree)	RAW VALUE (dBuV)	CORRECTION FACTOR (dB/m)
1	5150.00	62.5 PK	74.0	-11.5	1.12 H	205	54.20	8.30
2	5150.00	48.9 AV	54.0	-5.1	1.12 H	205	40.60	8.30
3	*5190.00	104.3 PK			1.02 H	243	62.70	41.60
4	*5190.00	94.2 AV			1.02 H	243	52.60	41.60
5	#10380.00	58.7 PK	74.0	-15.3	1.21 H	164	43.00	15.70
6	#10380.00	46.2 AV	54.0	-7.8	1.21 H	164	30.50	15.70

ANTENNA POLARITY & TEST DISTANCE: VERTICAL AT 3 M

NO.	FREQ. (MHz)	EMISSION LEVEL (dBuV/m)	LIMIT (dBuV/m)	MARGIN (dB)	ANTENNA HEIGHT (m)	TABLE ANGLE (Degree)	RAW VALUE (dBuV)	CORRECTION FACTOR (dB/m)
1	5150.00	66.2 PK	74.0	-7.8	1.03 V	251	57.90	8.30
2	5150.00	53.0 AV	54.0	-1.0	1.03 V	251	44.70	8.30
3	*5190.00	107.1 PK			1.23 V	302	65.50	41.60
4	*5190.00	96.7 AV			1.23 V	302	55.10	41.60
5	#10380.00	63.2 PK	74.0	-10.8	1.00 V	240	47.50	15.70
6	#10380.00	50.5 AV	54.0	-3.5	1.00 V	240	34.80	15.70

Remarks:

1. Emission Level(dBuV/m) = Raw Value(dBuV) + Correction Factor(dB/m)
2. Correction Factor(dB/m) = Antenna Factor(dB/m) + Cable Factor(dB)
3. The other emission levels were very low against the limit.
4. Margin value = Emission Level – Limit value
5. " * ": Fundamental frequency.
6. " # ": The radiated frequency is out of the restricted band.

CHANNEL	TX Channel 46	DETECTOR FUNCTION	Peak (PK)
FREQUENCY RANGE	1GHz ~ 40GHz		Average (AV)

ANTENNA POLARITY & TEST DISTANCE: HORIZONTAL AT 3 M								
NO.	FREQ. (MHz)	EMISSION LEVEL (dBuV/m)	LIMIT (dBuV/m)	MARGIN (dB)	ANTENNA HEIGHT (m)	TABLE ANGLE (Degree)	RAW VALUE (dBuV)	CORRECTION FACTOR (dB/m)
1	5150.00	56.5 PK	74.0	-17.5	1.12 H	273	48.20	8.30
2	5150.00	44.4 AV	54.0	-9.6	1.12 H	273	36.10	8.30
3	*5230.00	107.0 PK			1.00 H	269	65.20	41.80
4	*5230.00	97.5 AV			1.00 H	269	55.70	41.80
5	#10460.00	63.1 PK	74.0	-10.9	1.02 H	237	46.70	16.40
6	#10460.00	50.8 AV	54.0	-3.2	1.02 H	237	34.40	16.40
ANTENNA POLARITY & TEST DISTANCE: VERTICAL AT 3 M								
NO.	FREQ. (MHz)	EMISSION LEVEL (dBuV/m)	LIMIT (dBuV/m)	MARGIN (dB)	ANTENNA HEIGHT (m)	TABLE ANGLE (Degree)	RAW VALUE (dBuV)	CORRECTION FACTOR (dB/m)
1	5150.00	58.1 PK	74.0	-15.9	1.24 V	281	49.80	8.30
2	5150.00	46.0 AV	54.0	-8.0	1.24 V	281	37.70	8.30
3	*5230.00	111.5 PK			1.16 V	231	69.70	41.80
4	*5230.00	101.2 AV			1.16 V	231	59.40	41.80
5	#10460.00	68.5 PK	74.0	-5.5	1.00 V	232	52.10	16.40
6	#10460.00	53.5 AV	54.0	-0.5	1.00 V	232	37.10	16.40

Remarks:

1. Emission Level(dBuV/m) = Raw Value(dBuV) + Correction Factor(dB/m)
2. Correction Factor(dB/m) = Antenna Factor(dB/m) + Cable Factor(dB)
3. The other emission levels were very low against the limit.
4. Margin value = Emission Level – Limit value
5. " * ": Fundamental frequency.
6. " # ": The radiated frequency is out of the restricted band.

CHANNEL	TX Channel 151	DETECTOR FUNCTION	Peak (PK)
FREQUENCY RANGE	1GHz ~ 40GHz		Average (AV)

ANTENNA POLARITY & TEST DISTANCE: HORIZONTAL AT 3 M								
NO.	FREQ. (MHz)	EMISSION LEVEL (dBuV/m)	LIMIT (dBuV/m)	MARGIN (dB)	ANTENNA HEIGHT (m)	TABLE ANGLE (Degree)	RAW VALUE (dBuV)	CORRECTION FACTOR (dB/m)
1	#5714.90	61.0 PK	74.0	-13.0	1.00 H	185	51.40	9.60
2	#5714.90	48.7 AV	54.0	-5.3	1.00 H	185	39.10	9.60
3	#5722.90	68.8 PK	78.2	-9.4	1.09 H	198	59.20	9.60
4	#5725.00	55.5 PK	78.2	-22.7	1.23 H	215	45.90	9.60
5	*5755.00	102.6 PK			1.00 H	201	59.80	42.80
6	*5755.00	93.5 AV			1.00 H	201	50.70	42.80
7	11510.00	59.5 PK	74.0	-14.5	1.03 H	205	41.40	18.10
8	11510.00	47.4 AV	54.0	-6.6	1.03 H	205	29.30	18.10

ANTENNA POLARITY & TEST DISTANCE: VERTICAL AT 3 M								
NO.	FREQ. (MHz)	EMISSION LEVEL (dBuV/m)	LIMIT (dBuV/m)	MARGIN (dB)	ANTENNA HEIGHT (m)	TABLE ANGLE (Degree)	RAW VALUE (dBuV)	CORRECTION FACTOR (dB/m)
1	#5714.90	67.7 PK	74.0	-6.3	1.00 V	252	58.10	9.60
2	#5714.90	53.4 AV	54.0	-0.6	1.00 V	252	43.80	9.60
3	#5722.90	73.0 PK	78.2	-5.2	1.00 V	253	63.40	9.60
4	#5725.00	59.1 PK	78.2	-19.1	1.16 V	253	49.50	9.60
5	*5755.00	105.0 PK			1.04 V	238	62.20	42.80
6	*5755.00	95.6 AV			1.04 V	238	52.80	42.80
7	11510.00	60.5 PK	74.0	-13.5	1.32 V	217	42.40	18.10
8	11510.00	48.5 AV	54.0	-5.5	1.32 V	217	30.40	18.10

Remarks:

1. Emission Level(dBuV/m) = Raw Value(dBuV) + Correction Factor(dB/m)
2. Correction Factor(dB/m) = Antenna Factor(dB/m) + Cable Factor(dB)
3. The other emission levels were very low against the limit.
4. Margin value = Emission Level – Limit value
5. " * ": Fundamental frequency.
6. " # ": The radiated frequency is out of the restricted band.

CHANNEL	TX Channel 159	DETECTOR FUNCTION	Peak (PK)
FREQUENCY RANGE	1GHz ~ 40GHz		Average (AV)

ANTENNA POLARITY & TEST DISTANCE: HORIZONTAL AT 3 M								
NO.	FREQ. (MHz)	EMISSION LEVEL (dBuV/m)	LIMIT (dBuV/m)	MARGIN (dB)	ANTENNA HEIGHT (m)	TABLE ANGLE (Degree)	RAW VALUE (dBuV)	CORRECTION FACTOR (dB/m)
1	*5795.00	107.6 PK			1.00 H	186	64.70	42.90
2	*5795.00	97.7 AV			1.00 H	186	54.80	42.90
3	#5850.00	48.2 PK	78.2	-30.0	1.02 H	182	38.40	9.80
4	#5852.10	60.8 PK	78.2	-17.4	1.05 H	183	50.90	9.90
5	#5860.10	58.8 PK	74.0	-15.2	1.18 H	232	48.90	9.90
6	#5860.10	46.4 AV	54.0	-7.6	1.18 H	232	36.50	9.90
7	11590.00	61.0 PK	74.0	-13.0	1.15 H	227	42.70	18.30
8	11590.00	49.6 AV	54.0	-4.4	1.15 H	227	31.30	18.30

ANTENNA POLARITY & TEST DISTANCE: VERTICAL AT 3 M								
NO.	FREQ. (MHz)	EMISSION LEVEL (dBuV/m)	LIMIT (dBuV/m)	MARGIN (dB)	ANTENNA HEIGHT (m)	TABLE ANGLE (Degree)	RAW VALUE (dBuV)	CORRECTION FACTOR (dB/m)
1	*5795.00	109.2 PK			1.02 V	238	66.30	42.90
2	*5795.00	99.8 AV			1.02 V	238	56.90	42.90
3	#5850.00	53.3 PK	78.2	-24.9	1.03 V	276	43.50	9.80
4	#5852.10	65.3 PK	78.2	-12.9	1.04 V	263	55.40	9.90
5	#5860.10	62.3 PK	74.0	-11.7	1.13 V	291	52.40	9.90
6	#5860.10	49.2 AV	54.0	-4.8	1.13 V	291	39.30	9.90
7	11590.00	66.5 PK	74.0	-7.5	1.09 V	238	48.20	18.30
8	11590.00	53.5 AV	54.0	-0.5	1.09 V	238	35.20	18.30

Remarks:

1. Emission Level(dBuV/m) = Raw Value(dBuV) + Correction Factor(dB/m)
2. Correction Factor(dB/m) = Antenna Factor(dB/m) + Cable Factor(dB)
3. The other emission levels were very low against the limit.
4. Margin value = Emission Level – Limit value
5. " * ": Fundamental frequency.
6. " # ": The radiated frequency is out of the restricted band.

802.11ac (80MHz)

CHANNEL	TX Channel 42	DETECTOR FUNCTION	Peak (PK)
FREQUENCY RANGE	1GHz ~ 40GHz		Average (AV)

ANTENNA POLARITY & TEST DISTANCE: HORIZONTAL AT 3 M

NO.	FREQ. (MHz)	EMISSION LEVEL (dBuV/m)	LIMIT (dBuV/m)	MARGIN (dB)	ANTENNA HEIGHT (m)	TABLE ANGLE (Degree)	RAW VALUE (dBuV)	CORRECTION FACTOR (dB/m)
1	5150.00	63.4 PK	74.0	-10.6	1.15 H	262	57.20	6.20
2	5150.00	51.8 AV	54.0	-2.2	1.15 H	262	45.60	6.20
3	*5210.00	100.4 PK			1.00 H	262	60.80	39.60
4	*5210.00	90.9 AV			1.00 H	262	51.30	39.60
5	#10420.00	58.2 PK	74.0	-15.8	1.23 H	202	41.00	17.20
6	#10420.00	47.2 AV	54.0	-6.8	1.23 H	202	30.00	17.20

ANTENNA POLARITY & TEST DISTANCE: VERTICAL AT 3 M

NO.	FREQ. (MHz)	EMISSION LEVEL (dBuV/m)	LIMIT (dBuV/m)	MARGIN (dB)	ANTENNA HEIGHT (m)	TABLE ANGLE (Degree)	RAW VALUE (dBuV)	CORRECTION FACTOR (dB/m)
1	5150.00	66.1 PK	74.0	-7.9	1.05 V	245	59.90	6.20
2	5150.00	53.5 AV	54.0	-0.5	1.05 V	245	47.30	6.20
3	*5210.00	104.9 PK			1.09 V	261	65.30	39.60
4	*5210.00	95.6 AV			1.09 V	261	56.00	39.60
5	#10420.00	59.1 PK	74.0	-14.9	1.54 V	44	41.90	17.20
6	#10420.00	46.9 AV	54.0	-7.1	1.54 V	44	29.70	17.20

Remarks:

1. Emission Level(dBuV/m) = Raw Value(dBuV) + Correction Factor(dB/m)
2. Correction Factor(dB/m) = Antenna Factor(dB/m) + Cable Factor(dB)
3. The other emission levels were very low against the limit.
4. Margin value = Emission Level – Limit value
5. " * ": Fundamental frequency.
6. " # ": The radiated frequency is out of the restricted band.

CHANNEL	TX Channel 155	DETECTOR FUNCTION	Peak (PK)
FREQUENCY RANGE	1GHz ~ 40GHz		Average (AV)

ANTENNA POLARITY & TEST DISTANCE: HORIZONTAL AT 3 M								
NO.	FREQ. (MHz)	EMISSION LEVEL (dBuV/m)	LIMIT (dBuV/m)	MARGIN (dB)	ANTENNA HEIGHT (m)	TABLE ANGLE (Degree)	RAW VALUE (dBuV)	CORRECTION FACTOR (dB/m)
1	#5714.90	62.8 PK	74.0	-11.2	1.00 H	197	55.60	7.20
2	#5714.90	50.1 AV	54.0	-3.9	1.00 H	197	42.90	7.20
3	#5722.90	70.1 PK	78.2	-8.1	1.09 H	201	62.90	7.20
4	#5725.00	55.5 PK	78.2	-22.7	1.09 H	202	48.30	7.20
5	*5775.00	100.6 PK			1.00 H	204	60.10	40.50
6	*5775.00	90.8 AV			1.00 H	204	50.30	40.50
7	#5850.00	47.9 PK	78.2	-30.3	1.00 H	196	40.40	7.50
8	#5852.10	61.1 PK	78.2	-17.1	1.03 H	195	53.50	7.60
9	#5860.10	58.8 PK	74.0	-15.2	1.02 H	206	51.20	7.60
10	#5860.10	46.8 AV	54.0	-7.2	1.02 H	206	39.20	7.60
11	11550.00	59.2 PK	74.0	-14.8	1.13 H	139	41.00	18.20
12	11550.00	47.7 AV	54.0	-6.3	1.13 H	139	29.50	18.20

ANTENNA POLARITY & TEST DISTANCE: VERTICAL AT 3 M								
NO.	FREQ. (MHz)	EMISSION LEVEL (dBuV/m)	LIMIT (dBuV/m)	MARGIN (dB)	ANTENNA HEIGHT (m)	TABLE ANGLE (Degree)	RAW VALUE (dBuV)	CORRECTION FACTOR (dB/m)
1	#5714.90	67.5 PK	74.0	-6.5	1.00 V	278	60.30	7.20
2	#5714.90	53.3 AV	54.0	-0.7	1.00 V	278	46.10	7.20
3	#5722.90	72.8 PK	78.2	-5.4	1.01 V	262	65.60	7.20
4	#5725.00	58.7 PK	78.2	-19.5	1.03 V	258	51.50	7.20
5	*5775.00	101.6 PK			1.00 V	264	61.10	40.50
6	*5775.00	92.3 AV			1.00 V	264	51.80	40.50
7	#5850.00	51.0 PK	78.2	-27.2	1.00 V	278	43.50	7.50
8	#5852.10	65.6 PK	78.2	-12.6	1.13 V	271	58.00	7.60
9	#5860.10	61.8 PK	74.0	-12.2	1.16 V	267	54.20	7.60
10	#5860.10	50.0 AV	54.0	-4.0	1.16 V	267	42.40	7.60
11	11550.00	59.4 PK	74.0	-14.6	1.03 V	215	41.20	18.20
12	11550.00	48.1 AV	54.0	-5.9	1.03 V	215	29.90	18.20

Remarks:

1. Emission Level(dBuV/m) = Raw Value(dBuV) + Correction Factor(dB/m)
2. Correction Factor(dB/m) = Antenna Factor(dB/m) + Cable Factor(dB)
3. The other emission levels were very low against the limit.
4. Margin value = Emission Level – Limit value
5. " * ": Fundamental frequency.
6. " # ": The radiated frequency is out of the restricted band.

Below 1GHz Worst-Case Data: 802.11a

CHANNEL	TX Channel 36	DETECTOR FUNCTION	Quasi-Peak (QP)
FREQUENCY RANGE	30MHz ~ 1GHz		
TEST MODE	A		

ANTENNA POLARITY & TEST DISTANCE: HORIZONTAL AT 3 M

NO.	FREQ. (MHz)	EMISSION LEVEL (dBuV/m)	LIMIT (dBuV/m)	MARGIN (dB)	ANTENNA HEIGHT (m)	TABLE ANGLE (Degree)	RAW VALUE (dBuV)	CORRECTION FACTOR (dB/m)
1	57.12	31.7 QP	40.0	-8.3	2.00 H	5	46.30	-14.60
2	125.17	31.3 QP	43.5	-12.2	2.00 H	233	47.20	-15.90
3	300.16	37.7 QP	46.0	-8.3	1.00 H	115	49.90	-12.20
4	599.58	44.0 QP	46.0	-2.0	1.51 H	200	49.80	-5.80
5	712.35	40.9 QP	46.0	-5.1	1.00 H	124	44.60	-3.70
6	900.94	42.6 QP	46.0	-3.4	1.51 H	199	42.90	-0.30

ANTENNA POLARITY & TEST DISTANCE: VERTICAL AT 3 M

NO.	FREQ. (MHz)	EMISSION LEVEL (dBuV/m)	LIMIT (dBuV/m)	MARGIN (dB)	ANTENNA HEIGHT (m)	TABLE ANGLE (Degree)	RAW VALUE (dBuV)	CORRECTION FACTOR (dB/m)
1	125.17	32.8 QP	43.5	-10.7	1.00 V	303	48.70	-15.90
2	164.06	32.0 QP	43.5	-11.5	1.00 V	214	45.90	-13.90
3	300.16	39.0 QP	46.0	-7.0	1.49 V	139	51.20	-12.20
4	599.58	43.0 QP	46.0	-3.0	1.99 V	25	48.80	-5.80
5	712.35	36.0 QP	46.0	-10.0	1.49 V	11	39.70	-3.70
6	900.94	42.9 QP	46.0	-3.1	1.49 V	176	43.20	-0.30

Remarks:

1. Emission Level(dBuV/m) = Raw Value(dBuV) + Correction Factor(dB/m)
2. Correction Factor(dB/m) = Antenna Factor(dB/m) + Cable Factor(dB)
3. The other emission levels were very low against the limit.
4. Margin value = Emission Level – Limit value

CHANNEL	TX Channel 36	DETECTOR FUNCTION	Quasi-Peak (QP)
FREQUENCY RANGE	30MHz ~ 1GHz		
TEST MODE	B		

ANTENNA POLARITY & TEST DISTANCE: HORIZONTAL AT 3 M

NO.	FREQ. (MHz)	EMISSION LEVEL (dBuV/m)	LIMIT (dBuV/m)	MARGIN (dB)	ANTENNA HEIGHT (m)	TABLE ANGLE (Degree)	RAW VALUE (dBuV)	CORRECTION FACTOR (dB/m)
1	57.12	31.5 QP	40.0	-8.5	1.99 H	16	46.10	-14.60
2	142.67	31.3 QP	43.5	-12.2	1.99 H	281	45.40	-14.10
3	300.16	39.8 QP	46.0	-6.2	1.00 H	82	52.00	-12.20
4	364.32	31.5 QP	46.0	-14.5	1.00 H	130	42.50	-11.00
5	599.58	43.1 QP	46.0	-2.9	1.49 H	200	48.90	-5.80
6	900.94	43.3 QP	46.0	-2.7	1.00 H	291	43.60	-0.30

ANTENNA POLARITY & TEST DISTANCE: VERTICAL AT 3 M

NO.	FREQ. (MHz)	EMISSION LEVEL (dBuV/m)	LIMIT (dBuV/m)	MARGIN (dB)	ANTENNA HEIGHT (m)	TABLE ANGLE (Degree)	RAW VALUE (dBuV)	CORRECTION FACTOR (dB/m)
1	43.51	38.9 QP	40.0	-1.1	1.00 V	280	53.70	-14.80
2	300.16	36.1 QP	46.0	-9.9	2.00 V	181	48.30	-12.20
3	364.32	32.1 QP	46.0	-13.9	1.50 V	308	43.10	-11.00
4	599.58	41.4 QP	46.0	-4.6	1.00 V	48	47.20	-5.80
5	747.34	38.4 QP	46.0	-7.6	1.00 V	57	41.20	-2.80
6	902.89	44.0 QP	46.0	-2.0	1.00 V	152	44.30	-0.30

Remarks:

1. Emission Level(dBuV/m) = Raw Value(dBuV) + Correction Factor(dB/m)
2. Correction Factor(dB/m) = Antenna Factor(dB/m) + Cable Factor(dB)
3. The other emission levels were very low against the limit.
4. Margin value = Emission Level – Limit value

4.2 Conducted Emission Measurement

4.2.1 Limits of Conducted Emission Measurement

Frequency (MHz)	Conducted Limit (dBuV)	
	Quasi-peak	Average
0.15 - 0.5	66 - 56	56 - 46
0.50 - 5.0	56	46
5.0 - 30.0	60	50

- Note:** 1. The lower limit shall apply at the transition frequencies.
 2. The limit decreases in line with the logarithm of the frequency in the range of 0.15 to 0.50MHz.

4.2.2 Test Instruments

Description & Manufacturer	Model No.	Serial No.	Cal. Date	Cal. Due
Test Receiver ROHDE & SCHWARZ	ESCI	100613	Nov. 16, 2015	Nov. 15, 2016
RF signal cable (with 10dB PAD) Woken	5D-FB	Cable-cond1-01	Dec. 26, 2015	Dec. 25, 2016
LISN ROHDE & SCHWARZ (EUT)	ESH3-Z5	835239/001	Feb. 26, 2015	Feb. 25, 2016
LISN ROHDE & SCHWARZ (Peripheral)	ESH3-Z5	100311	Jul. 24, 2015	Jul. 23, 2016
Software ADT	BV ADT_Cond_ V7.3.7.3	NA	NA	NA

- Note:** 1. The calibration interval of the above test instruments is 12 months and the calibrations are traceable to NML/ROC and NIST/USA.
 2. The test was performed in HwaYa Shielded Room 1.
 3. The VCCI Site Registration No. is C-2040.

4.2.3 Test Procedures

- The EUT was placed 0.4 meters from the conducting wall of the shielded room with EUT being connected to the power mains through a line impedance stabilization network (LISN). Other support units were connected to the power mains through another LISN. The two LISNs provide 50 ohm/ 50uH of coupling impedance for the measuring instrument.
- Both lines of the power mains connected to the EUT were checked for maximum conducted interference.
- The frequency range from 150kHz to 30MHz was searched. Emission levels under (Limit - 20dB) was not recorded.

NOTE: The resolution bandwidth and video bandwidth of test receiver is 9kHz for quasi-peak detection (QP) and average detection (AV) at frequency 0.15MHz-30MHz.

4.2.4 Deviation from Test Standard

No deviation.

4.2.5 Test Setup

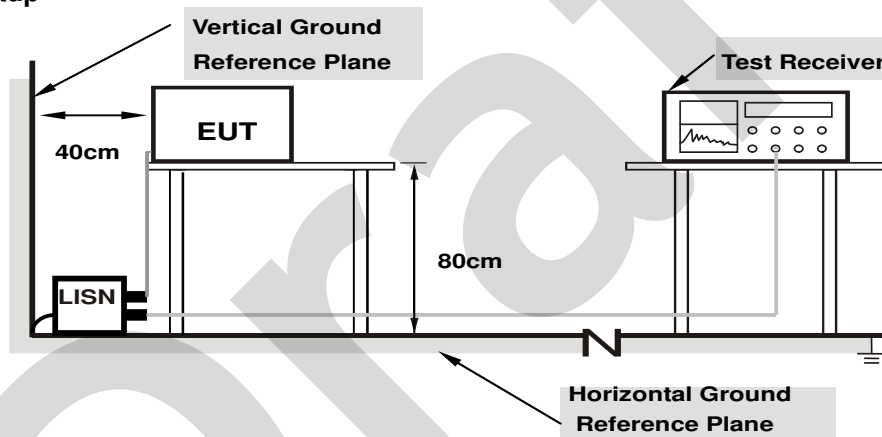

For the actual test configuration, please refer to the attached file (Test Setup Photo).

4.2.6 EUT Operating Conditions

Same as 4.1.6.

4.2.7 Test Results

Worst-Case Data: 802.11a

Phase	Line (L)	Detector Function	Quasi-Peak (QP) / Average (AV)
Test Mode	A		

No	Freq. [MHz]	Corr. Factor (dB)	Reading Value		Emission Level		Limit		Margin	
			[dB (uV)]		[dB (uV)]		[dB (uV)]		(dB)	
			Q.P.	AV.	Q.P.	AV.	Q.P.	AV.	Q.P.	AV.
1	0.15400	9.93	22.48	21.06	32.41	30.99	65.78	55.78	-33.37	-24.79
2	0.19400	9.95	26.68	16.84	36.63	26.79	63.86	53.86	-27.24	-27.08
3	0.22600	9.96	26.00	15.54	35.96	25.50	62.60	52.60	-26.64	-27.10
4	0.26600	9.98	19.82	9.47	29.80	19.45	61.24	51.24	-31.45	-31.80
5	11.46600	10.66	12.15	1.00	22.81	11.66	60.00	50.00	-37.19	-38.34
6	18.36600	10.97	14.98	9.50	25.95	20.47	60.00	50.00	-34.05	-29.53

Remarks:

1. Q.P. and AV. are abbreviations of quasi-peak and average individually.
2. The emission levels of other frequencies were very low against the limit.
3. Margin value = Emission level - Limit value
4. Correction factor = Insertion loss + Cable loss
5. Emission Level = Correction Factor + Reading Value.

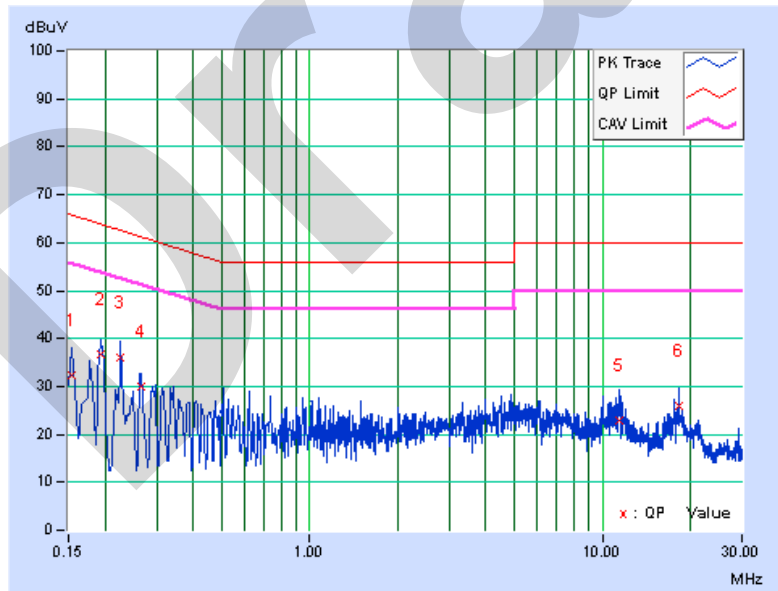

Phase	Neutral (N)	Detector Function	Quasi-Peak (QP) / Average (AV)
Test Mode	A		

No	Freq. [MHz]	Corr. Factor (dB)	Reading Value [dB (uV)]		Emission Level [dB (uV)]		Limit [dB (uV)]		Margin (dB)	
			Q.P.	AV.	Q.P.	AV.	Q.P.	AV.	Q.P.	AV.
			1	0.16579	9.93	26.44	9.72	36.37	19.65	65.17
2	0.23723	9.96	18.49	5.26	28.45	15.22	62.19	52.19	-33.75	-36.98
3	0.28200	9.98	20.24	3.42	30.22	13.40	60.76	50.76	-30.54	-37.36
4	0.44645	10.04	14.08	2.32	24.12	12.36	56.94	46.94	-32.82	-34.58
5	11.37400	10.60	11.44	0.01	22.04	10.61	60.00	50.00	-37.96	-39.39
6	17.69800	10.79	12.50	5.10	23.29	15.89	60.00	50.00	-36.71	-34.11

Remarks:

1. Q.P. and AV. are abbreviations of quasi-peak and average individually.
2. The emission levels of other frequencies were very low against the limit.
3. Margin value = Emission level - Limit value
4. Correction factor = Insertion loss + Cable loss
5. Emission Level = Correction Factor + Reading Value.

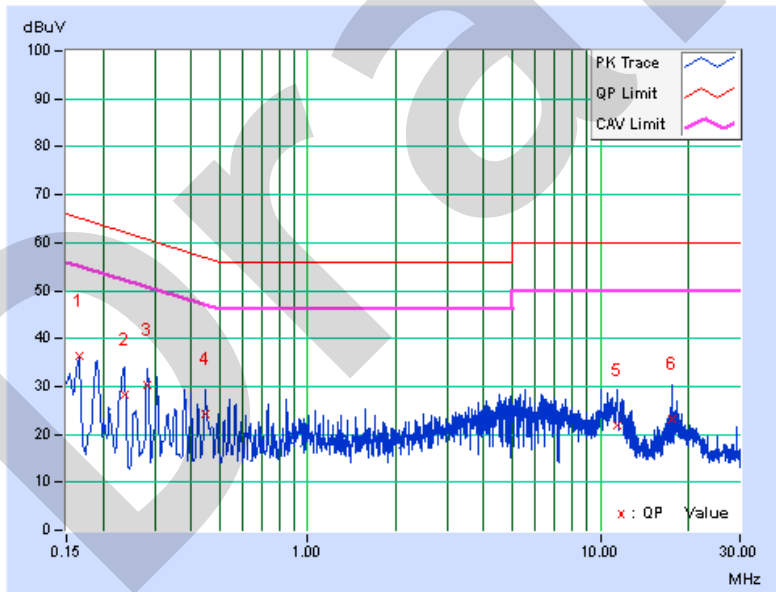

Phase	Line (L)	Detector Function	Quasi-Peak (QP) / Average (AV)
Test Mode	B		

No	Freq. [MHz]	Corr. Factor (dB)	Reading Value [dB (uV)]		Emission Level [dB (uV)]		Limit [dB (uV)]		Margin (dB)	
			Q.P.	AV.	Q.P.	AV.	Q.P.	AV.	Q.P.	AV.
			1	0.16564	9.98	43.53	26.52	53.51	36.50	65.18
2	0.17346	10.00	42.11	24.94	52.11	34.94	64.79	54.79	-12.68	-19.85
3	0.23602	10.06	31.95	18.46	42.01	28.52	62.24	52.24	-20.23	-23.72
4	0.32187	10.06	32.12	25.47	42.18	35.53	59.66	49.66	-17.48	-14.13
5	2.93783	10.28	20.15	12.98	30.43	23.26	56.00	46.00	-25.57	-22.74
6	8.12640	10.56	23.71	17.62	34.27	28.18	60.00	50.00	-25.73	-21.82

Remarks:

1. Q.P. and AV. are abbreviations of quasi-peak and average individually.
2. The emission levels of other frequencies were very low against the limit.
3. Margin value = Emission level - Limit value
4. Correction factor = Insertion loss + Cable loss
5. Emission Level = Correction Factor + Reading Value.

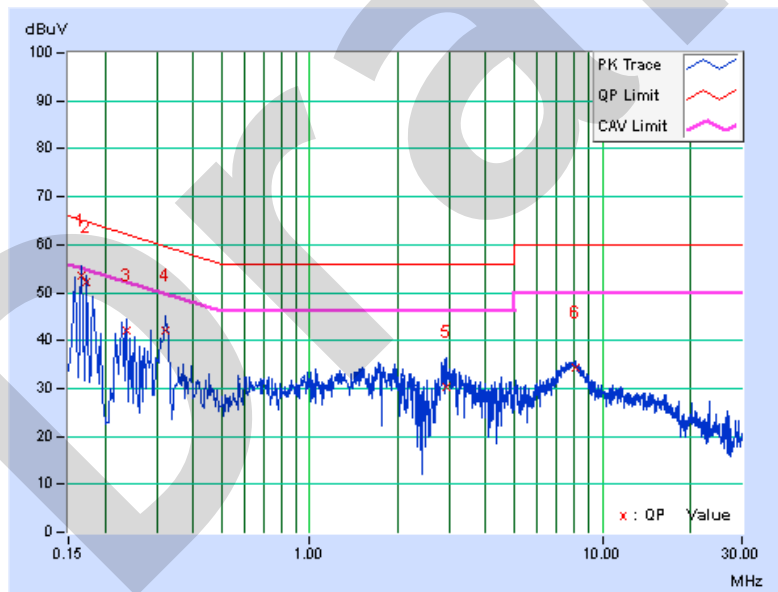

Phase	Neutral (N)	Detector Function	Quasi-Peak (QP) / Average (AV)
Test Mode	B		

No	Freq. [MHz]	Corr. Factor (dB)	Reading Value [dB (uV)]		Emission Level [dB (uV)]		Limit [dB (uV)]		Margin (dB)	
			Q.P.	AV.	Q.P.	AV.	Q.P.	AV.	Q.P.	AV.
			1	0.15391	9.97	44.44	29.43	54.41	39.40	65.79
2	0.16569	9.98	43.69	28.05	53.67	38.03	65.17	55.17	-11.51	-17.15
3	0.18122	9.99	38.20	22.22	48.19	32.21	64.43	54.43	-16.24	-22.22
4	0.32187	10.07	36.63	30.79	46.70	40.86	59.66	49.66	-12.96	-8.80
5	2.81271	10.33	25.28	19.93	35.61	30.26	56.00	46.00	-20.39	-15.74
6	7.65720	10.56	22.65	17.07	33.21	27.63	60.00	50.00	-26.79	-22.37

Remarks:

1. Q.P. and AV. are abbreviations of quasi-peak and average individually.
2. The emission levels of other frequencies were very low against the limit.
3. Margin value = Emission level - Limit value
4. Correction factor = Insertion loss + Cable loss
5. Emission Level = Correction Factor + Reading Value.

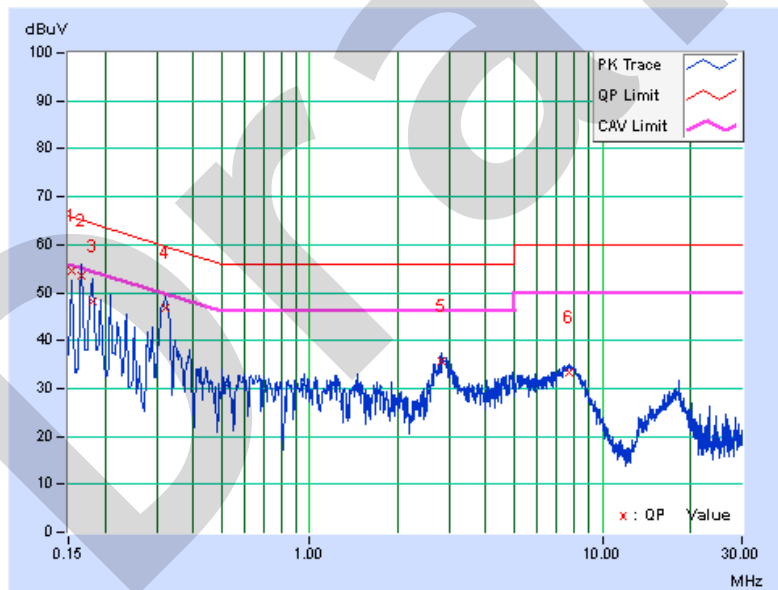

4.3 Transmit Power Measurement

4.3.1 Limits of Transmit Power Measurement

Operation Band	EUT Category		LIMIT
U-NII-1		Outdoor Access Point	1 Watt (30 dBm) (Max. e.i.r.p \leq 125mW(21 dBm) at any elevation angle above 30 degrees as measured from the horizon)
		Fixed point-to-point Access Point	1 Watt (30 dBm)
	√	Indoor Access Point	1 Watt (30 dBm)
		Mobile and Portable client device	250mW (24 dBm)
U-NII-2A	---		250mW (24 dBm) or 11 dBm+10 log B*
U-NII-2C	---		250mW (24 dBm) or 11 dBm+10 log B*
U-NII-3	√		1 Watt (30 dBm)

*B is the 26 dB emission bandwidth in megahertz

Per KDB 662911 Method of conducted output power measurement on IEEE 802.11 devices,

Array Gain = 0 dB (i.e., no array gain) for $N_{ANT} \leq 4$;

Array Gain = 0 dB (i.e., no array gain) for channel widths ≥ 40 MHz for any N_{ANT} ;

Array Gain = $5 \log(N_{ANT}/N_{SS})$ dB or 3 dB, whichever is less for 20-MHz channel widths with $N_{ANT} \geq 5$.

For power measurements on all other devices: Array Gain = $10 \log(N_{ANT}/N_{SS})$ dB.

4.3.2 Test Setup

For 802.11a, 802.11n (20MHz), 802.11n (40MHz), 802.11ac (20MHz), 802.11ac (40MHz)

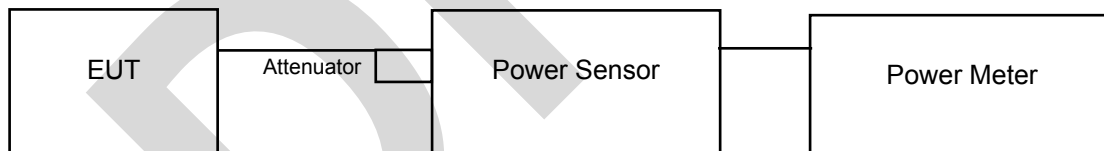

For 802.11ac (80MHz)

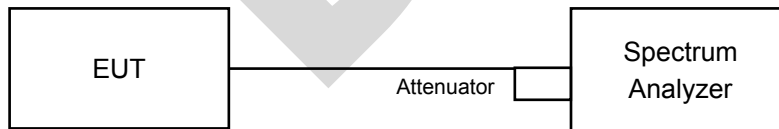

4.3.3 Test Instruments

Refer to section 4.1.2 to get information of above instrument.

4.3.4 Test Procedure

For Average Power Measurement

For 802.11a, 802.11n (20MHz), 802.11n (40MHz), 802.11ac (20MHz), 802.11ac (40MHz)

Method PM is used to perform output power measurement, trigger and gating function of wide band power meter is enabled to measure max output power of TX on burst. Duty factor is not added to measured value.

For 802.11ac (80MHz)

- a. Set span to encompass the entire 26 dB EBW (or, alternatively, the entire 99% occupied bandwidth) of the signal.
- b. Set sweep trigger to “free run”.
- c. Set RBW = 1 MHz.
- d. Set VBW \geq 3 MHz
- e. Number of points in sweep \geq 2 Span / RBW.
- f. Sweep time \leq (number of points in sweep) * T
- g. Using emission bandwidth to determine the frequency span for integration the channel bandwidth.
- h. Detector = RMS.
- i. Trace mode = max hold.
- j. Allow max hold to run for at least 60 seconds, or longer as needed to allow the trace to stabilize.
- k. Compute power by integrating the spectrum across the EBW (or, alternatively, the entire 99% occupied bandwidth) of the signal using the instrument’s band power measurement function with band limits set equal to the EBW (or occupied bandwidth) band edges. If the instrument does not have a band power function, sum the spectrum levels (in power units) at 1 MHz intervals extending across the EBW (or, alternatively, the entire 99% occupied bandwidth) of the spectrum.

4.3.5 Deviation from Test Standard

No deviation.

4.3.6 EUT Operating Conditions

The software provided by client to enable the EUT under transmission condition continuously at lowest, middle and highest channel frequencies individually.

4.3.7 Test Result

Power Output:

802.11a

Chan.	Freq. (MHz)	Maximum Conducted Power (mW)	Maximum Conducted Power (dBm)	Power Limit (dBm)	Pass / Fail
36	5180	88.308	19.46	30	Pass
40	5200	68.707	18.37	30	Pass
48	5240	51.642	17.13	30	Pass
149	5745	67.608	18.30	30	Pass
157	5785	57.677	17.61	30	Pass
165	5825	41.305	16.16	30	Pass

802.11n (20MHz)

Chan.	Freq. (MHz)	Maximum Conducted Power (dBm)		Total Power (mW)	Total Power (dBm)	Power Limit (dBm)	Pass / Fail
		Chain 0	Chain 1				
36	5180	19.34	19.14	167.936	22.25	30	Pass
40	5200	18.11	17.85	125.668	20.99	30	Pass
48	5240	17.11	16.49	95.970	19.82	30	Pass
149	5745	18.35	17.09	119.559	20.78	30	Pass
157	5785	17.22	16.75	100.038	20.00	30	Pass
165	5825	15.82	15.69	75.262	18.77	30	Pass

802.11n (40MHz)

Chan.	Freq. (MHz)	Maximum Conducted Power (dBm)		Total Power (mW)	Total Power (dBm)	Power Limit (dBm)	Pass / Fail
		Chain 0	Chain 1				
38	5190	15.56	14.69	65.419	18.16	30	Pass
46	5230	18.56	18.21	138.001	21.40	30	Pass
151	5755	13.86	13.04	44.459	16.48	30	Pass
159	5795	19.27	18.34	152.762	21.84	30	Pass

802.11ac (20MHz)

Chan.	Freq. (MHz)	Maximum Conducted Power (dBm)		Total Power (mW)	Total Power (dBm)	Power Limit (dBm)	Pass / Fail
		Chain 0	Chain 1				
36	5180	19.51	19.31	174.641	22.42	30	Pass
40	5200	18.29	17.98	130.259	21.15	30	Pass
48	5240	17.28	16.65	99.694	19.99	30	Pass
149	5745	18.41	17.24	122.309	20.87	30	Pass
157	5785	17.31	16.83	102.022	20.09	30	Pass
165	5825	16.01	16.80	87.765	19.43	30	Pass

802.11ac (40MHz)

Chan.	Freq. (MHz)	Maximum Conducted Power (dBm)		Total Power (mW)	Total Power (dBm)	Power Limit (dBm)	Pass / Fail
		Chain 0	Chain 1				
38	5190	15.76	14.81	67.939	18.32	30	Pass
46	5230	18.77	18.34	143.570	21.57	30	Pass
151	5755	13.99	13.25	46.196	16.65	30	Pass
159	5795	19.50	18.53	160.410	22.05	30	Pass

802.11ac (80MHz)

Chan.	Freq. (MHz)	Maximum Conducted Power (dBm)		Total Power (mW)	Total Power (dBm)	Power Limit (dBm)	Pass / Fail
		Chain 0	Chain 1				
42	5210	13.69	13.21	44.329	16.47	30	Pass
155	5775	13.48	11.84	37.560	15.75	30	Pass

26dB Bandwidth:
802.11a

Chan.	Freq. (MHz)	26dBc Bandwidth (MHz)	Pass / Fail
36	5180	24.28	Pass
40	5200	23.45	Pass
48	5240	22.87	Pass

802.11n (20MHz)

Chan.	Freq. (MHz)	26dBc Bandwidth (MHz)		Pass / Fail
		Chain 0	Chain 1	
36	5180	23.92	23.95	Pass
40	5200	23.44	23.78	Pass
48	5240	22.83	22.60	Pass

802.11n (40MHz)

Chan.	Freq. (MHz)	26dBc Bandwidth (MHz)		Pass / Fail
		Chain 0	Chain 1	
38	5190	46.32	46.73	Pass
46	5230	47.54	47.65	Pass

802.11ac (20MHz)

Chan.	Freq. (MHz)	26dBc Bandwidth (MHz)		Pass / Fail
		Chain 0	Chain 1	
36	5180	24.66	24.06	Pass
40	5200	23.91	23.75	Pass
48	5240	23.79	23.12	Pass

802.11ac (40MHz)

Chan.	Freq. (MHz)	26dBc Bandwidth (MHz)		Pass / Fail
		Chain 0	Chain 1	
38	5190	45.69	46.43	Pass
46	5230	47.01	46.89	Pass

802.11ac (80MHz)

Chan.	Freq. (MHz)	26dBc Bandwidth (MHz)		Pass / Fail
		Chain 0	Chain 1	
42	5210	87.85	89.07	Pass

Spectrum Plot of Worst Value

802.11a

802.11n (20MHz)

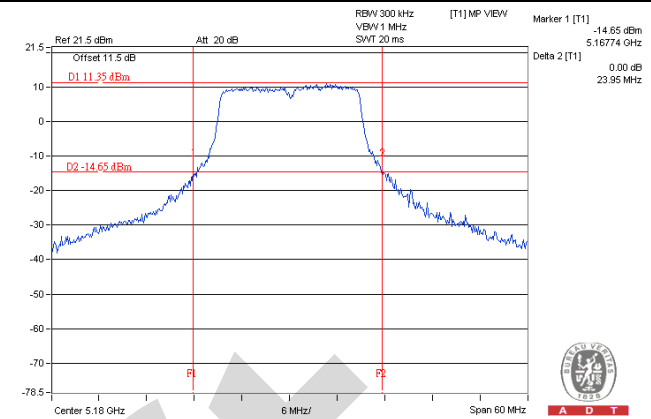
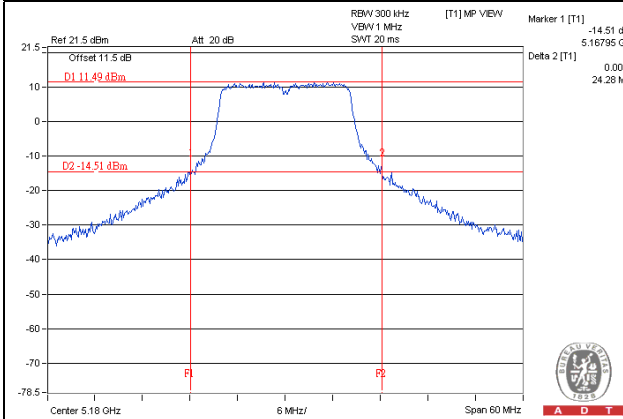

802.11n (40MHz)

802.11ac (20MHz)

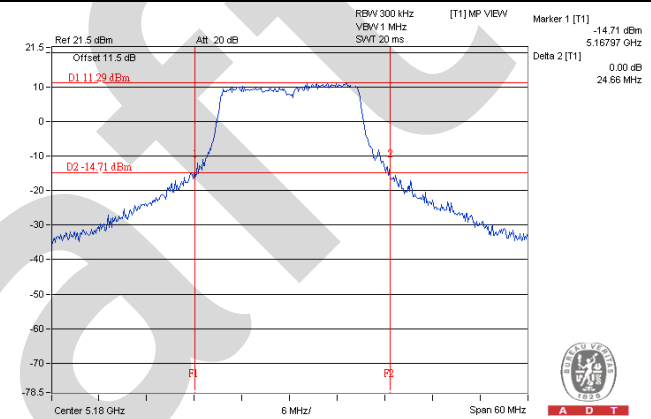
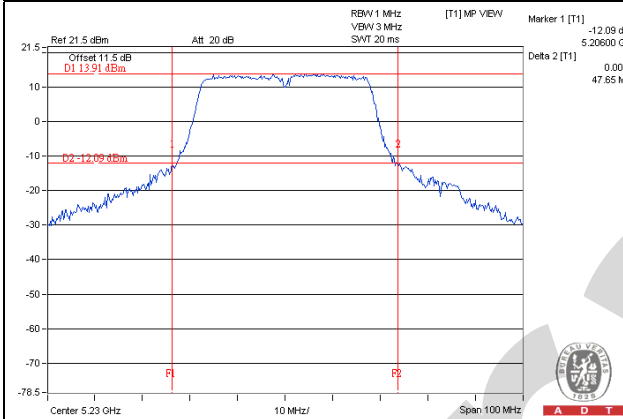

802.11ac (40MHz)

802.11ac (80MHz)

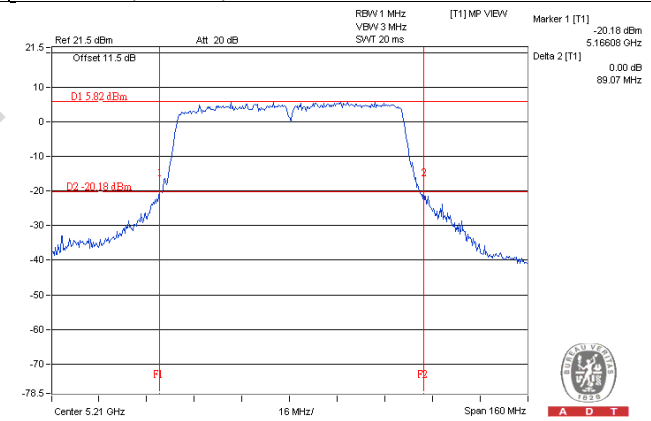
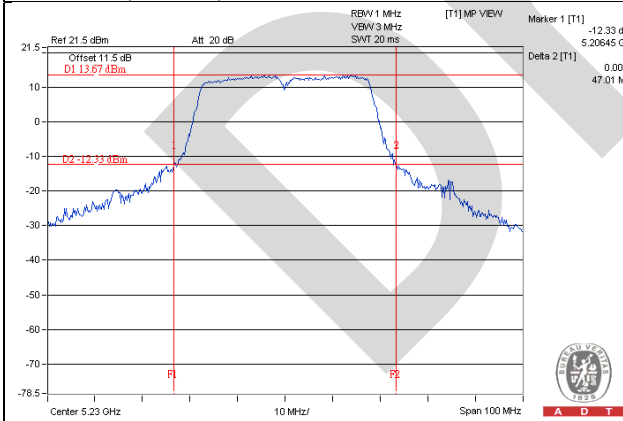

Occupied Bandwidth:
802.11a

Chan.	Freq. (MHz)	Occupied Bandwidth (MHz)
36	5180	16.80
40	5200	16.80
48	5240	16.80
149	5745	16.80
157	5785	16.80
165	5825	16.68

802.11n (20MHz)

Chan.	Freq. (MHz)	Occupied Bandwidth (MHz)	
		Chain 0	Chain 1
36	5180	18.00	17.88
40	5200	17.88	18.00
48	5240	17.88	17.88
149	5745	17.88	17.88
157	5785	18.00	18.00
165	5825	17.88	17.88

802.11n (40MHz)

Chan.	Freq. (MHz)	Occupied Bandwidth (MHz)	
		Chain 0	Chain 1
38	5190	36.72	36.60
46	5230	36.60	36.72
151	5755	36.72	36.72
159	5795	36.84	36.60

802.11ac (20MHz)

Chan.	Freq. (MHz)	Occupied Bandwidth (MHz)	
		Chain 0	Chain 1
36	5180	18.12	18.00
40	5200	18.00	18.00
48	5240	18.00	18.00
149	5745	18.00	17.76
157	5785	18.00	17.88
165	5825	17.88	17.88

802.11ac (40MHz)

Chan.	Freq. (MHz)	Occupied Bandwidth (MHz)	
		Chain 0	Chain 1
38	5190	36.84	36.60
46	5230	36.84	36.84
151	5755	36.84	36.84
159	5795	36.96	36.84

802.11ac (80MHz)

Chan.	Freq. (MHz)	Occupied Bandwidth (MHz)	
		Chain 0	Chain 1
42	5210	75.84	75.84
155	5775	76.08	75.84

Spectrum Plot of Worst Value

802.11a

802.11n (20MHz)

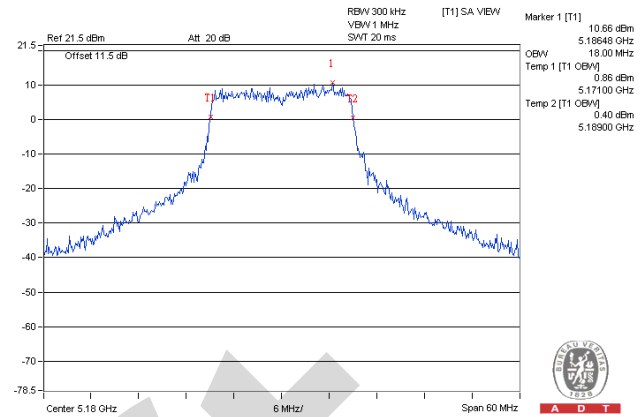
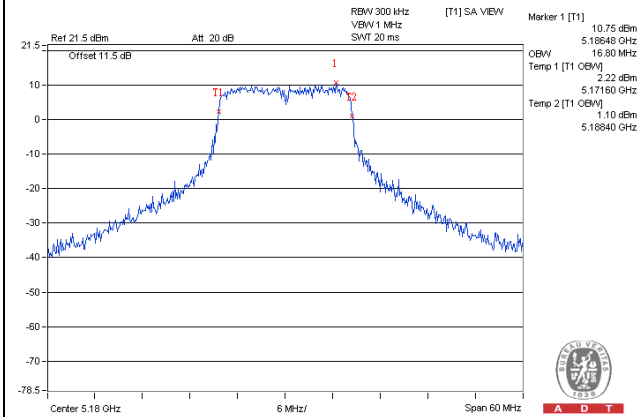

802.11n (40MHz)

802.11ac (20MHz)

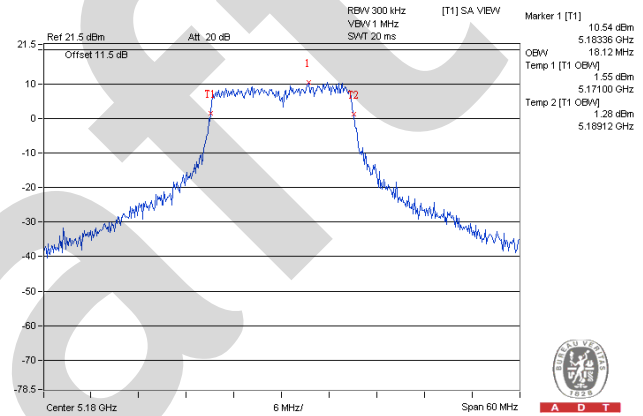
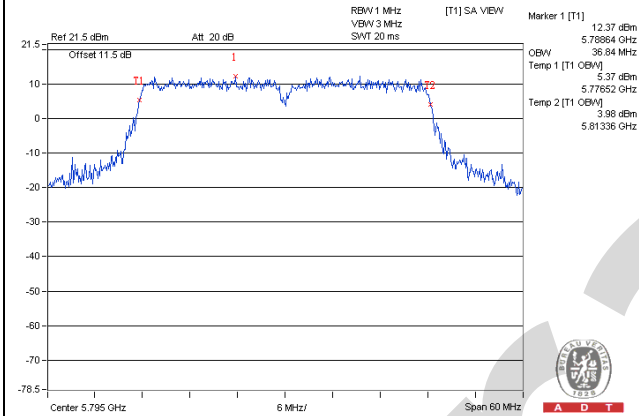

802.11ac (40MHz)

802.11ac (80MHz)

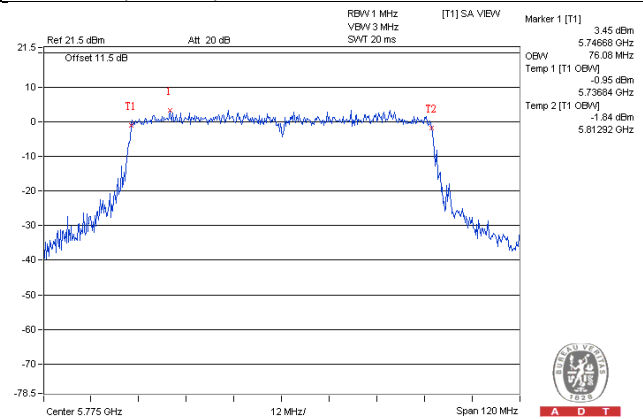
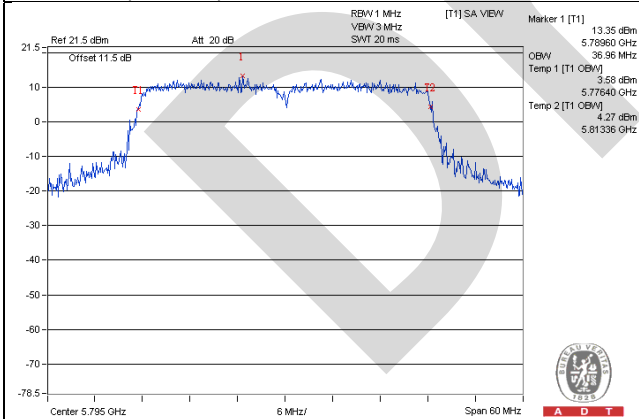

4.4 Peak Power Spectral Density Measurement

4.4.1 Limits of Peak Power Spectral Density Measurement

Operation Band	EUT Category		LIMIT
U-NII-1		Outdoor Access Point	17dBm/ MHz
		Fixed point-to-point Access Point	
	√	Indoor Access Point	11dBm/ MHz
		Mobile and Portable client device	
U-NII-2A	---		11dBm/ MHz
U-NII-2C	---		11dBm/ MHz
U-NII-3	√		30dBm/ 500kHz

4.4.2 Test Setup

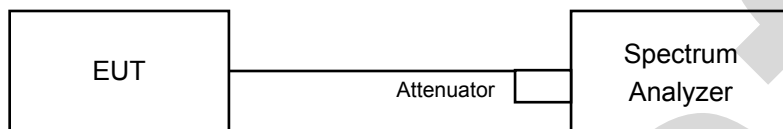

4.4.3 Test Instruments

Refer to section 4.1.2 to get information of above instrument.

4.4.4 Test Procedures

For U-NII-1 band:

Using method SA-2

- Set span to encompass the entire emission bandwidth (EBW) of the signal.
- Set RBW = 1 MHz, Set VBW ≥ 3 MHz, Detector = RMS
- Sweep time = auto, trigger set to “free run”.
- Trace average at least 100 traces in power averaging mode.
- Record the max value and add 10 log (1/duty cycle)

For U-NII-3 band:

- Set span to encompass the entire emission bandwidth (EBW) of the signal.
- Set RBW = 300 kHz, Set VBW ≥ 1 MHz, Detector = RMS
- Use the peak marker function to determine the maximum power level in any 300 kHz band segment within the fundamental EBW.
- Scale the observed power level to an equivalent value in 500 kHz by adjusting (reducing) the measured power by a bandwidth correction factor (BWCF) where $BWCF = 10\log(500\text{ kHz}/300\text{kHz})$
- Sweep time = auto, trigger set to “free run”.
- Trace average at least 100 traces in power averaging mode.
- Record the max value and add 10 log (1/duty cycle)

4.4.5 Deviation from Test Standard

No deviation.

4.4.6 EUT Operating Conditions

Same as Item 4.3.6.

Draft

4.4.7 Test Results

For U-NII-1 Band

802.11a

Chan.	Freq. (MHz)	PSD w/o duty factor (dBm)	Duty factor	PSD with duty factor (dBm)	Max. Limit (dBm)	Pass / Fail
36	5180	6.29	0.18	6.47	17.00	Pass
40	5200	5.24	0.18	5.42	17.00	Pass
48	5240	4.31	0.18	4.49	17.00	Pass

Note: Refer to section 3.3 for duty cycle spectrum plot.

802.11n (20MHz)

Chan.	Freq. (MHz)	PSD (dBm)		Total PSD w/o duty factor (dBm)	Duty factor	Total PSD with duty factor (dBm)	Max. Limit (dBm)	Pass / Fail
		Chain 0	Chain 1					
36	5180	5.71	5.43	8.58	0.15	8.73	16.85	Pass
40	5200	3.75	5.00	7.43	0.15	7.58	16.85	Pass
48	5240	3.11	3.94	6.55	0.15	6.70	16.85	Pass

Note:

- Method 1 of power density measurement of KDB 662911 is using for calculating total power density. Total power density is summing entire spectra across corresponding frequency bins on the various outputs by computer.
- Directional gain = $10 \log[(10^{G1/20} + 10^{G2/20} + \dots + 10^{GN/20})^2 / N_{ANT}] = 6.15\text{dBi} > 6\text{dBi}$, so the power density limit shall be reduced to $17 - (6.15 - 6) = 16.85\text{dBm}$.
- Refer to section 3.3 for duty cycle spectrum plot.

802.11n (40MHz)

Chan.	Freq. (MHz)	PSD (dBm)		Total PSD w/o duty factor (dBm)	Duty factor	Total PSD with duty factor (dBm)	Max. Limit (dBm)	Pass / Fail
		Chain 0	Chain 1					
38	5190	-1.27	-1.74	1.52	0.52	2.04	16.85	Pass
46	5230	2.09	2.49	5.31	0.52	5.83	16.85	Pass

Note:

- Method 1 of power density measurement of KDB 662911 is using for calculating total power density. Total power density is summing entire spectra across corresponding frequency bins on the various outputs by computer.
- Directional gain = $10 \log[(10^{G1/20} + 10^{G2/20} + \dots + 10^{GN/20})^2 / N_{ANT}] = 6.15\text{dBi} > 6\text{dBi}$, so the power density limit shall be reduced to $17 - (6.15 - 6) = 16.85\text{dBm}$.
- Refer to section 3.3 for duty cycle spectrum plot.

802.11ac (20MHz)

Chan.	Freq. (MHz)	PSD (dBm)		Total PSD w/o duty factor (dBm)	Duty factor	Total PSD with duty factor (dBm)	Max. Limit (dBm)	Pass / Fail
		Chain 0	Chain 1					
36	5180	6.14	5.33	8.76	0.17	8.93	16.85	Pass
40	5200	4.05	5.14	7.64	0.17	7.81	16.85	Pass
48	5240	3.35	3.80	6.59	0.17	6.76	16.85	Pass

Note:

- Method 1 of power density measurement of KDB 662911 is using for calculating total power density. Total power density is summing entire spectra across corresponding frequency bins on the various outputs by computer.
- Directional gain = $10 \log[(10^{G1/20} + 10^{G2/20} + \dots + 10^{GN/20})^2 / N_{ANT}] = 6.15\text{dBi} > 6\text{dBi}$, so the power density limit shall be reduced to $17 - (6.15 - 6) = 16.85\text{dBm}$.
- Refer to section 3.3 for duty cycle spectrum plot.

802.11ac (40MHz)

Chan.	Freq. (MHz)	PSD (dBm)		Total PSD w/o duty factor (dBm)	Duty factor	Total PSD with duty factor (dBm)	Max. Limit (dBm)	Pass / Fail
		Chain 0	Chain 1					
38	5190	-1.24	-1.91	1.45	0.57	2.02	16.85	Pass
46	5230	2.22	1.99	5.12	0.57	5.69	16.85	Pass

Note:

- Method 1 of power density measurement of KDB 662911 is using for calculating total power density. Total power density is summing entire spectra across corresponding frequency bins on the various outputs by computer.
- Directional gain = $10 \log[(10^{G1/20} + 10^{G2/20} + \dots + 10^{GN/20})^2 / N_{ANT}] = 6.15\text{dBi} > 6\text{dBi}$, so the power density limit shall be reduced to $17 - (6.15 - 6) = 16.85\text{dBm}$.
- Refer to section 3.3 for duty cycle spectrum plot.

802.11ac (80MHz)

Chan.	Freq. (MHz)	PSD (dBm)		Total PSD w/o duty factor (dBm)	Duty factor	Total PSD with duty factor (dBm)	Max. Limit (dBm)	Pass / Fail
		Chain 0	Chain 1					
42	5210	-6.10	-5.98	-3.02	0.86	-2.16	14.99	Pass

Note:

- Method 1 of power density measurement of KDB 662911 is using for calculating total power density. Total power density is summing entire spectra across corresponding frequency bins on the various outputs by computer.
- Directional gain = $10 \log[(10^{G1/20} + 10^{G2/20} + \dots + 10^{GN/20})^2 / N_{ANT}] = 6.15\text{dBi} > 6\text{dBi}$, so the power density limit shall be reduced to $17 - (6.15 - 6) = 16.85\text{dBm}$.
- Refer to section 3.3 for duty cycle spectrum plot.

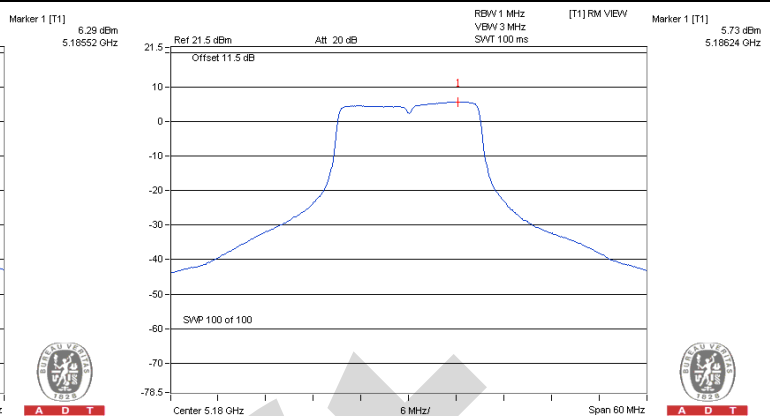
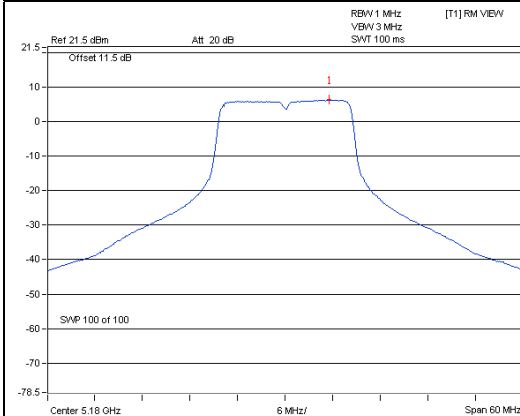
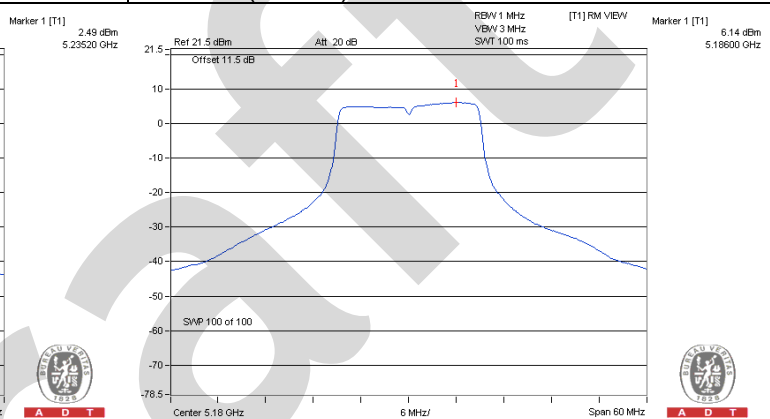
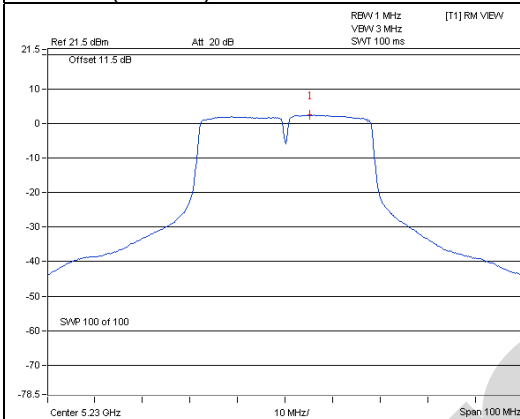
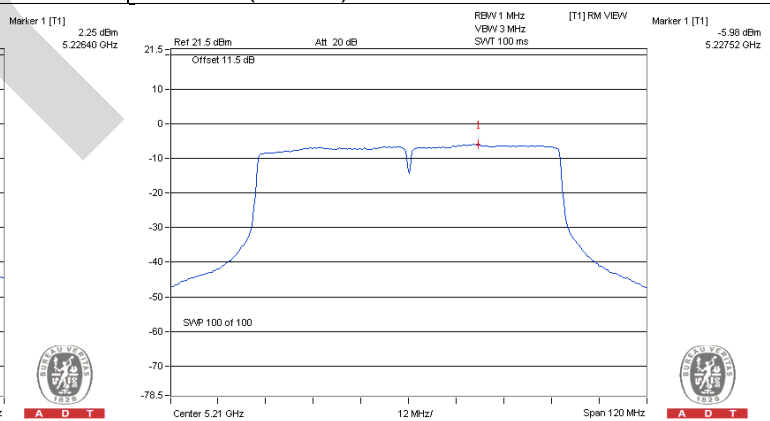
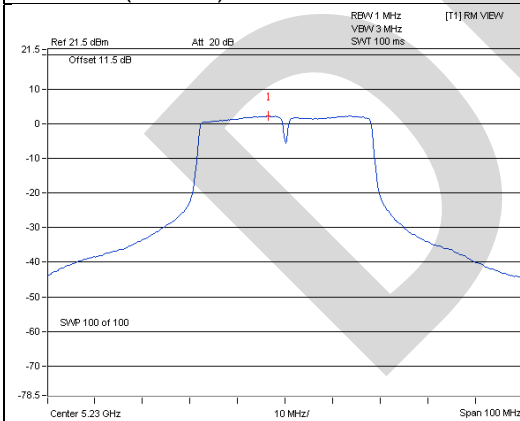
Spectrum Plot of Worst Value**802.11a / CH 36****802.11n (20MHz) / Chain 0 / CH 36****802.11n (40MHz) / Chain 1 / CH 46****802.11ac (20MHz) / Chain 0 / CH 36****802.11ac (40MHz) / Chain 0 / CH 46****802.11ac (80MHz) / Chain 1 / CH 42**

For U-NII-3 Band

802.11a

Chan.	Freq. (MHz)	PSD (dBm/300k Hz)	PSD (dBm/500k Hz)	Duty factor	Total PSD (dBm/500k Hz)	Limit (dBm/500k Hz)	Pass / Fail
149	5745	-2.91	-0.69	0.18	-0.51	30.00	Pass
157	5785	-3.58	-1.36	0.18	-1.18	30.00	Pass
165	5825	-5.60	-3.38	0.18	-3.20	30.00	Pass

Note: Refer to section 3.3 for duty cycle spectrum plot.

802.11n (20MHz)

TX chain	Chan.	Freq. (MHz)	PSD (dBm/300 kHz)	PSD (dBm/500 kHz)	10 log (N=2) dB	Duty factor	Total PSD (dBm/500 kHz)	Limit (dBm/500 kHz)	Pass / Fail
0	149	5745	-3.64	-1.42	3.01	0.15	1.74	29.85	Pass
	157	5785	-4.12	-1.90	3.01	0.15	1.26	29.85	Pass
	165	5825	-5.46	-3.24	3.01	0.15	-0.08	29.85	Pass
1	149	5745	-4.72	-2.50	3.01	0.15	0.66	29.85	Pass
	157	5785	-4.67	-2.45	3.01	0.15	0.71	29.85	Pass
	165	5825	-5.43	-3.21	3.01	0.15	-0.05	29.85	Pass

Note:

- Method 1 of power density measurement of KDB 662911 is using for calculating total power density. Total power density is summing entire spectra across corresponding frequency bins on the various outputs by computer.
- Directional gain = $10 \log[(10^{G1/20} + 10^{G2/20} + \dots + 10^{GN/20})^2 / N_{ANT}] = 6.15 \text{dBi} > 6 \text{dBi}$, so the power density limit shall be reduced to $30 - (6.15 - 6) = 29.85 \text{dBm}$.
- Refer to section 3.3 for duty cycle spectrum plot.

802.11n (40MHz)

TX chain	Chan.	Freq. (MHz)	PSD (dBm/300 kHz)	PSD (dBm/500 kHz)	10 log (N=2) dB	Duty factor	Total PSD (dBm/500 kHz)	Limit (dBm/500 kHz)	Pass / Fail
0	151	5755	-10.91	-8.69	3.01	0.52	-5.16	29.85	Pass
	159	5795	-6.58	-4.36	3.01	0.52	-0.83	29.85	Pass
1	151	5755	-11.99	-9.77	3.01	0.52	-6.24	29.85	Pass
	159	5795	-7.09	-4.87	3.01	0.52	-1.34	29.85	Pass

Note:

- Method 1 of power density measurement of KDB 662911 is using for calculating total power density. Total power density is summing entire spectra across corresponding frequency bins on the various outputs by computer.
- Directional gain = $10 \log[(10^{G1/20} + 10^{G2/20} + \dots + 10^{GN/20})^2 / N_{ANT}] = 6.15 \text{dBi} > 6 \text{dBi}$, so the power density limit shall be reduced to $30 - (6.15 - 6) = 29.85 \text{dBm}$.
- Refer to section 3.3 for duty cycle spectrum plot.

802.11ac (20MHz)

TX chain	Chan.	Freq. (MHz)	PSD (dBm/300 kHz)	PSD (dBm/500 kHz)	10 log (N=2) dB	Duty factor	Total PSD (dBm/500 kHz)	Limit (dBm/500 kHz)	Pass / Fail
0	149	5745	-3.25	-1.03	3.01	0.17	2.15	29.85	Pass
	157	5785	-4.33	-2.11	3.01	0.17	1.07	29.85	Pass
	165	5825	-6.28	-4.06	3.01	0.17	-0.88	29.85	Pass
1	149	5745	-4.56	-2.34	3.01	0.17	0.84	29.85	Pass
	157	5785	-5.13	-2.91	3.01	0.17	0.27	29.85	Pass
	165	5825	-6.25	-4.03	3.01	0.17	-0.85	29.85	Pass

Note:

- Method 1 of power density measurement of KDB 662911 is using for calculating total power density. Total power density is summing entire spectra across corresponding frequency bins on the various outputs by computer.
- Directional gain = $10 \log[(10^{G1/20} + 10^{G2/20} + \dots + 10^{GN/20})^2 / N_{ANT}] = 6.15\text{dBi} > 6\text{dBi}$, so the power density limit shall be reduced to $30 - (6.15 - 6) = 29.85\text{dBm}$.
- Refer to section 3.3 for duty cycle spectrum plot.

802.11ac (40MHz)

TX chain	Chan.	Freq. (MHz)	PSD (dBm/300 kHz)	PSD (dBm/500 kHz)	10 log (N=2) dB	Duty factor	Total PSD (dBm/500 kHz)	Limit (dBm/500 kHz)	Pass / Fail
0	151	5755	-10.56	-8.34	3.01	0.57	-4.76	29.85	Pass
	159	5795	-6.19	-3.97	3.01	0.57	-0.39	29.85	Pass
1	151	5755	-11.86	-9.64	3.01	0.57	-6.06	29.85	Pass
	159	5795	-6.77	-4.55	3.01	0.57	-0.97	29.85	Pass

Note:

- Method 1 of power density measurement of KDB 662911 is using for calculating total power density. Total power density is summing entire spectra across corresponding frequency bins on the various outputs by computer.
- Directional gain = $10 \log[(10^{G1/20} + 10^{G2/20} + \dots + 10^{GN/20})^2 / N_{ANT}] = 6.15\text{dBi} > 6\text{dBi}$, so the power density limit shall be reduced to $30 - (6.15 - 6) = 29.85\text{dBm}$.
- Refer to section 3.3 for duty cycle spectrum plot.

802.11ac (80MHz)

TX chain	Chan.	Freq. (MHz)	PSD (dBm/300 kHz)	PSD (dBm/500 kHz)	10 log (N=3) dB	Duty factor	Total PSD (dBm/500 kHz)	Limit (dBm/500 kHz)	Pass / Fail
0	155	5775	-15.37	-13.15	3.01	0.86	-9.28	29.85	Pass
1	155	5775	-15.69	-13.47	3.01	0.86	-9.60	29.85	Pass

Note:

- Method 1 of power density measurement of KDB 662911 is using for calculating total power density. Total power density is summing entire spectra across corresponding frequency bins on the various outputs by computer.
- Directional gain = $10 \log[(10^{G1/20} + 10^{G2/20} + \dots + 10^{GN/20})^2 / N_{ANT}] = 6.15\text{dBi} > 6\text{dBi}$, so the power density limit shall be reduced to $30 - (6.15 - 6) = 29.85\text{dBm}$.
- Refer to section 3.3 for duty cycle spectrum plot.

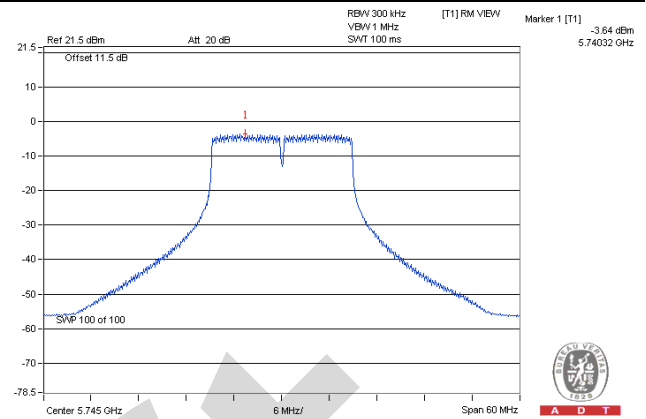
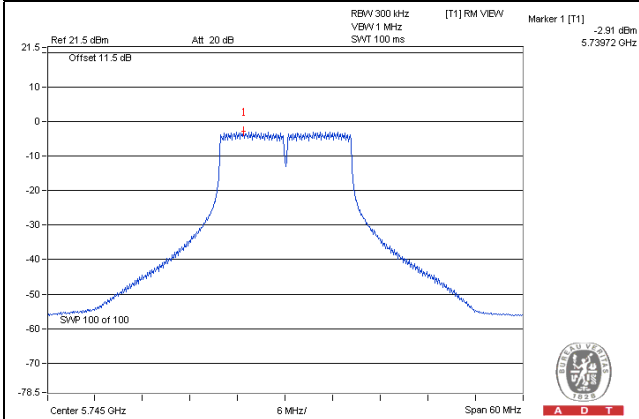
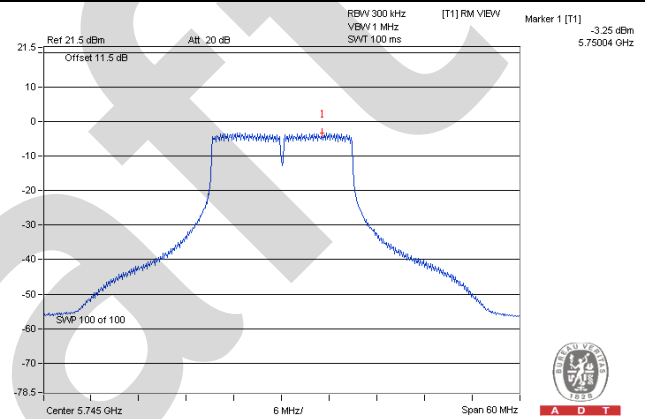
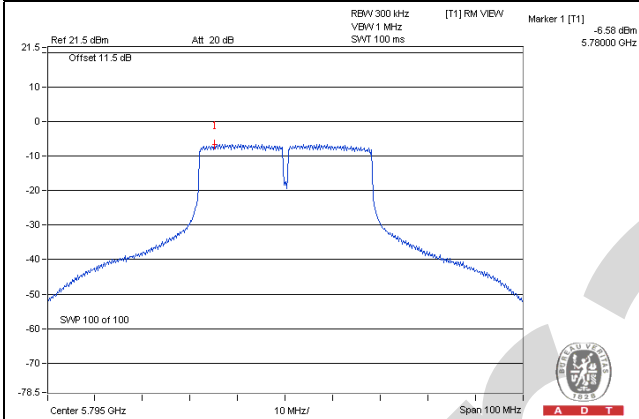
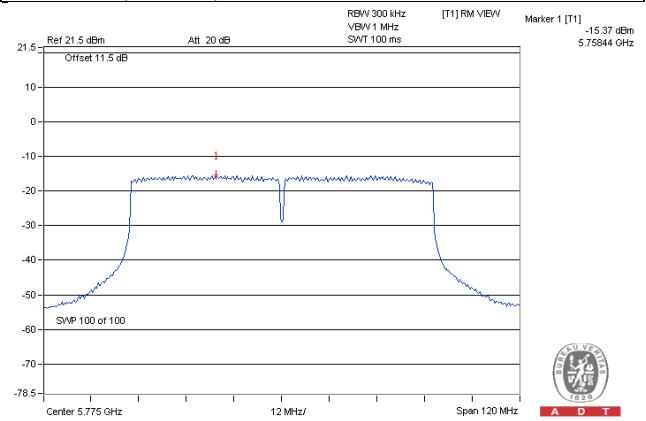
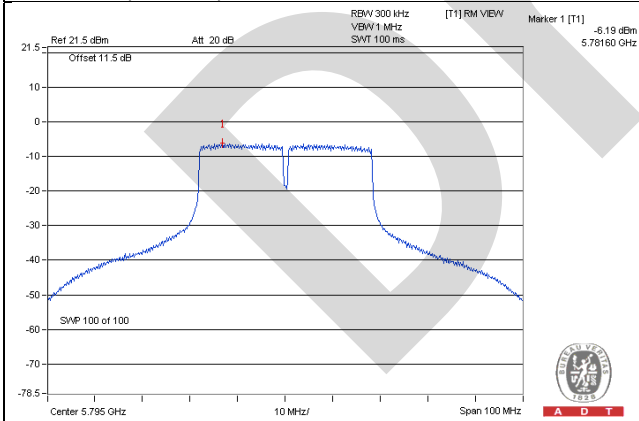
Spectrum Plot of Worst Value**802.11a****802.11n (20MHz)****802.11n (40MHz)****802.11ac (20MHz)****802.11ac (40MHz)****802.11ac (80MHz)**

4.5 Frequency Stability

4.5.1 Limits of Frequency Stability Measurement

The frequency of the carrier signal shall be maintained within band of operation

4.5.2 Test Setup

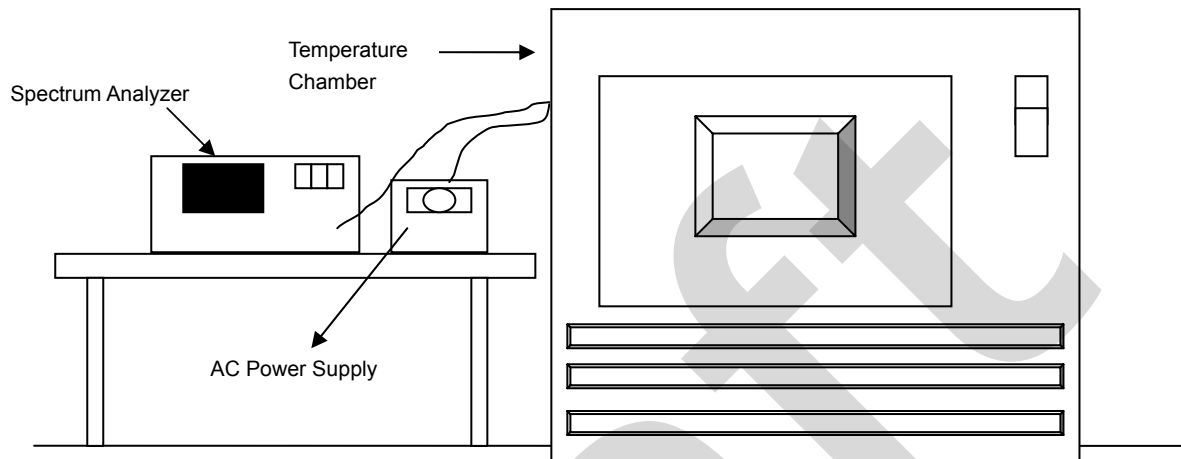

4.5.3 Test Instruments

Refer to section 4.1.2 to get information of above instrument.

4.5.4 Test Procedure

- The EUT was placed inside the environmental test chamber and powered by nominal AC voltage.
- Turn the EUT on and couple its output to a spectrum analyzer.
- Turn the EUT off and set the chamber to the highest temperature specified.
- Allow sufficient time (approximately 30 min) for the temperature of the chamber to stabilize, turn the EUT on and measure the operating frequency after 2, 5, and 10 minutes.
- Repeat step 2 and 3 with the temperature chamber set to the lowest temperature.
- The test chamber was allowed to stabilize at +20 degree C for a minimum of 30 minutes. The supply voltage was then adjusted on the EUT from 85% to 115% and the frequency record.

4.5.5 Deviation from Test Standard

No deviation.

4.5.6 EUT Operating Condition

Set the EUT transmit at un-modulation mode to test frequency stability.

4.5.7 Test Results

Frequency Stability Versus Temp.									
Operating Frequency: 5180MHz									
Temp. (°C)	Power Supply (Vac)	0 Minute		2 Minute		5 Minute		10 Minute	
		Measured Frequency (MHz)	Frequency Drift (%)	Measured Frequency (MHz)	Frequency Drift (%)	Measured Frequency (MHz)	Frequency Drift (%)	Measured Frequency (MHz)	Frequency Drift (%)
50	120	5179.9754	-0.00047	5179.9742	-0.00050	5179.9771	-0.00044	5179.9743	-0.00050
40	120	5180.0035	0.00007	5180.0037	0.00007	5180.0046	0.00009	5180.0022	0.00004
30	120	5180.0212	0.00041	5180.0173	0.00033	5180.0199	0.00038	5180.0192	0.00037
20	120	5179.9929	-0.00014	5179.9913	-0.00017	5179.9931	-0.00013	5179.9932	-0.00013
10	120	5179.9843	-0.00030	5179.984	-0.00031	5179.9819	-0.00035	5179.9805	-0.00038
0	120	5179.9916	-0.00016	5179.9891	-0.00021	5179.99	-0.00019	5179.9917	-0.00016
-10	120	5179.9768	-0.00045	5179.9768	-0.00045	5179.9802	-0.00038	5179.981	-0.00037
-20	120	5180.0017	0.00003	5179.9991	-0.00002	5179.9973	-0.00005	5179.9978	-0.00004
-30	120	5179.99	-0.00019	5179.9914	-0.00017	5179.9892	-0.00021	5179.9885	-0.00022

Frequency Stability Versus Voltage.									
Operating Frequency: 5180MHz									
Temp. (°C)	Power Supply (Vac)	0 Minute		2 Minute		5 Minute		10 Minute	
		Measured Frequency (MHz)	Frequency Drift (%)	Measured Frequency (MHz)	Frequency Drift (%)	Measured Frequency (MHz)	Frequency Drift (%)	Measured Frequency (MHz)	Frequency Drift (%)
20	138	5179.9932	-0.00013	5179.9919	-0.00016	5179.9922	-0.00015	5179.9931	-0.00013
	120	5179.9929	-0.00014	5179.9913	-0.00017	5179.9931	-0.00013	5179.9932	-0.00013
	102	5179.9928	-0.00014	5179.9908	-0.00018	5179.9926	-0.00014	5179.9923	-0.00015

4.6 6dB Bandwidth Measurement

4.6.1 Limits of 6dB Bandwidth Measurement

The minimum of 6dB Bandwidth Measurement is 0.5MHz.

4.6.2 Test Setup

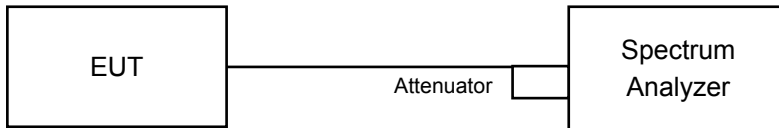

4.6.3 Test Instruments

Refer to section 4.1.2 to get information of above instrument.

4.6.4 Test Procedure

MEASUREMENT PROCEDURE REF

- Set resolution bandwidth (RBW) = 100kHz
- Set the video bandwidth (VBW) $\geq 3 \times$ RBW, Detector = Peak.
- Trace mode = max hold.
- Sweep = auto couple.
- Measure the maximum width of the emission that is constrained by the frequencies associated with the two amplitude points (upper and lower) that are attenuated by 6 dB relative to the maximum level measured in the fundamental emission

4.6.5 Deviation from Test Standard

No deviation.

4.6.6 EUT Operating Condition

The software provided by client to enable the EUT under transmission condition continuously at lowest, middle and highest channel frequencies individually.

4.6.7 Test Results

802.11a

Chan.	Freq. (MHz)	6dB Bandwidth (MHz)	Minimum Limit (MHz)	Pass / Fail
149	5745	16.40	0.5	Pass
157	5785	16.41	0.5	Pass
165	5825	16.39	0.5	Pass

802.11n (20MHz)

Chan.	Freq. (MHz)	6dB Bandwidth (MHz)		Minimum Limit (MHz)	Pass / Fail
		Chain 0	Chain 1		
149	5745	17.65	17.66	0.5	Pass
157	5785	17.63	17.62	0.5	Pass
165	5825	17.63	17.35	0.5	Pass

802.11n (40MHz)

Chan.	Freq. (MHz)	6dB Bandwidth (MHz)		Minimum Limit (MHz)	Pass / Fail
		Chain 0	Chain 1		
151	5755	36.35	35.78	0.5	Pass
159	5795	36.43	35.88	0.5	Pass

802.11ac (20MHz)

Chan.	Freq. (MHz)	6dB Bandwidth (MHz)		Minimum Limit (MHz)	Pass / Fail
		Chain 0	Chain 1		
149	5745	17.64	16.72	0.5	Pass
157	5785	17.60	17.18	0.5	Pass
165	5825	17.62	17.64	0.5	Pass

802.11ac (40MHz)

Chan.	Freq. (MHz)	6dB Bandwidth (MHz)		Minimum Limit (MHz)	Pass / Fail
		Chain 0	Chain 1		
151	5755	36.34	35.78	0.5	Pass
159	5795	36.41	35.79	0.5	Pass

802.11ac (80MHz)

Chan.	Freq. (MHz)	6dB Bandwidth (MHz)		Minimum Limit (MHz)	Pass / Fail
		Chain 0	Chain 1		
155	5775	76.44	73.46	0.5	Pass

Spectrum Plot of Worst Value

802.11a

802.11n (20MHz)

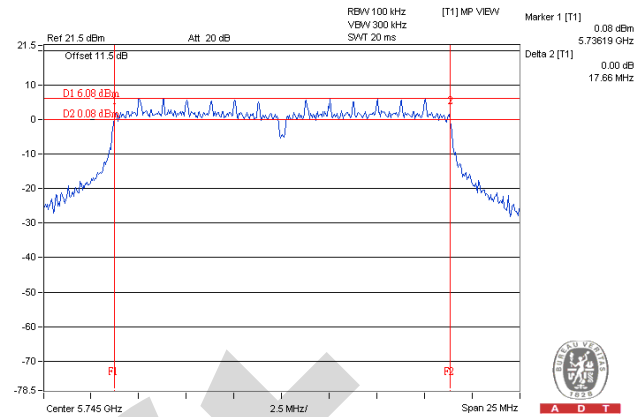
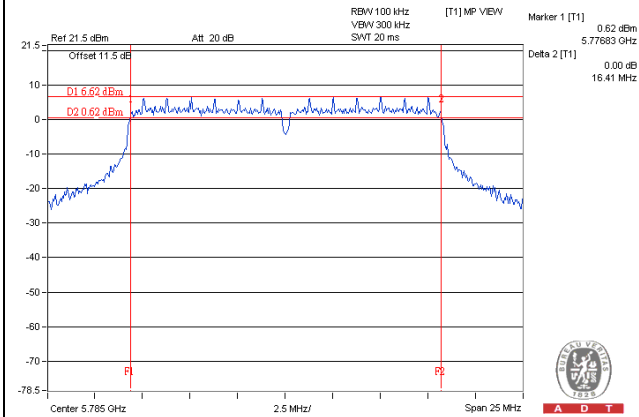

802.11n (40MHz)

802.11ac (20MHz)

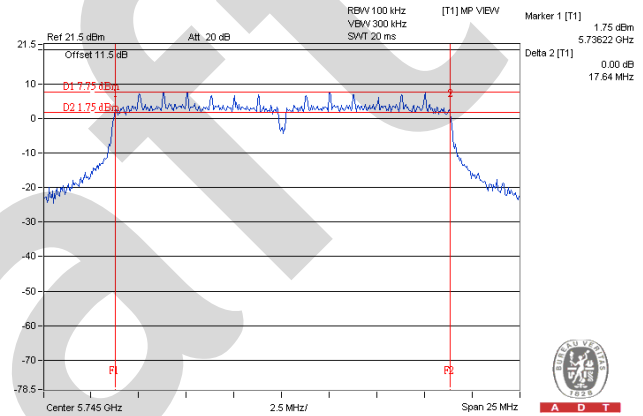
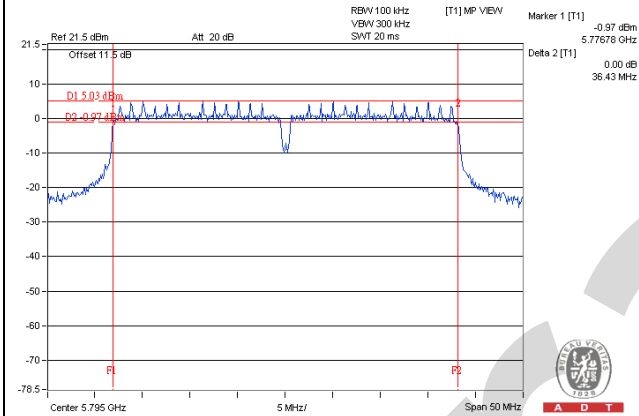

802.11ac (40MHz)

802.11ac (80MHz)

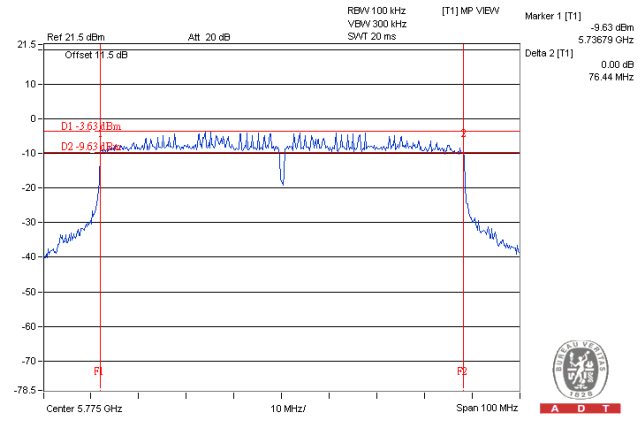
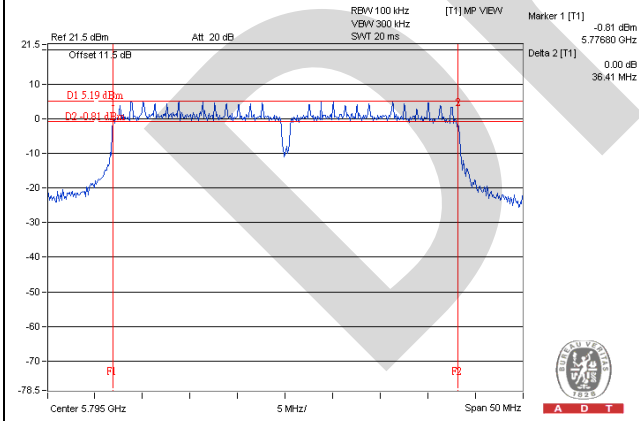

5 Pictures of Test Arrangements

Please refer to the attached file (Test Setup Photo).

Draft

Appendix – Information on the Testing Laboratories

We, Bureau Veritas Consumer Products Services (H.K.) Ltd., Taoyuan Branch, were founded in 1988 to provide our best service in EMC, Radio, Telecom and Safety consultation. Our laboratories are accredited and approved according to ISO/IEC 17025.

If you have any comments, please feel free to contact us at the following:

Linko EMC/RF Lab

Tel: 886-2-26052180

Fax: 886-2-26051924

Hsin Chu EMC/RF/Telecom Lab

Tel: 886-3-6668565

Fax: 886-3-6668323

Hwa Ya EMC/RF/Safety Lab

Tel: 886-3-3183232

Fax: 886-3-3270892

Email: service.adt@tw.bureauveritas.com

Web Site: www.bureauveritas-adt.com

The address and road map of all our labs can be found in our web site also.

--- END ---

Draft