



A D T

FCC Test Report

Report No.: RF150417C34A

FCC ID: WT8OM5PAC

Test Model: OM5P-AC

Received Date: Dec. 18, 2015

Test Date: Jan. 08 ~ Jan. 23, 2016

Issued Date: Jan. 25, 2016

Applicant: Open Mesh, Inc.

Address: 5 Centerpointe Drive, Suite 400, Lake Oswego, Oregon, USA 97035

Issued By: Bureau Veritas Consumer Products Services (H.K.) Ltd., Taoyuan Branch

Lab Address: No. 47-2, 14th Ling, Chia Pau Vil., Lin Kou Dist., New Taipei City, Taiwan, R.O.C.

Test Location: No.19, Hwa Ya 2nd Rd., Wen Hwa Vil., Kwei Shan Dist., Taoyuan City 33383, TAIWAN (R.O.C.)



This report is for your exclusive use. Any copying or replication of this report to or for any other person or entity, or use of our name or trademark, is permitted only with our prior written permission. This report sets forth our findings solely with respect to the test samples identified herein. The results set forth in this report are not indicative or representative of the quality or characteristics of the lot from which a test sample was taken or any similar or identical product specifically and expressly noted. Our report includes all of the tests requested by you and the results thereof based upon the information that you provided to us. You have 60 days from date of issuance of this report to notify us of any material error or omission caused by our negligence, provided, however, that such notice shall be in writing and shall specifically address the issue you wish to raise. A failure to raise such issue within the prescribed time shall constitute your unqualified acceptance of the completeness of this report, the tests conducted and the correctness of the report contents. Unless specific mention, the uncertainty of measurement has been explicitly taken into account to declare the compliance or non-compliance to the specification. This report should not be used by the client to claim product certification, approval, or endorsement by TAF or any government agencies.

Table of Contents

Release Control Record 4

1 Certificate of Conformity 5

2 Summary of Test Results 6

2.1 Measurement Uncertainty 6

2.2 Modification Record 6

3 General Information 7

3.1 General Description of EUT 7

3.2 Description of Test Modes 8

3.2.1 Test Mode Applicability and Tested Channel Detail 9

3.3 Duty Cycle of Test Signal 11

3.4 Description of Support Units 12

3.4.1 Configuration of System under Test 13

3.5 General Description of Applied Standards 14

4 Test Types and Results 15

4.1 Radiated Emission and Bandedge Measurement 15

4.1.1 Limits of Radiated Emission and Bandedge Measurement 15

4.1.2 Test Instruments 16

4.1.3 Test Procedures 17

4.1.4 Deviation from Test Standard 17

4.1.5 Test Set Up 18

4.1.6 EUT Operating Conditions 18

4.1.7 Test Results 19

4.2 Conducted Emission Measurement 33

4.2.1 Limits of Conducted Emission Measurement 33

4.2.2 Test Instruments 33

4.2.3 Test Procedures 34

4.2.4 Deviation from Test Standard 34

4.2.5 Test Setup 34

4.2.6 EUT Operating Conditions 34

4.2.7 Test Results 35

4.3 6dB Bandwidth Measurement 39

4.3.1 Limits of 6dB Bandwidth Measurement 39

4.3.2 Test Setup 39

4.3.3 Test Instruments 39

4.3.4 Test Procedure 39

4.3.5 Deviation from Test Standard 39

4.3.6 EUT Operating Conditions 39

4.3.7 Test Result 40

4.4 Conducted Output Power Measurement 42

4.4.1 Limits of Conducted Output Power Measurement 42

4.4.2 Test Setup 42

4.4.3 Test Instruments 42

4.4.4 Test Procedures 42

4.4.5 Deviation from Test Standard 42

4.4.6 EUT Operating Conditions 42

4.4.7 Test Results 43

4.5 Power Spectral Density Measurement 44

4.5.1 Limits of Power Spectral Density Measurement 44

4.5.2 Test Setup 44

4.5.3 Test Instruments 44

4.5.4 Test Procedure 44

4.5.5 Deviation from Test Standard 45

4.5.6 EUT Operating Condition 45



4.5.7 Test Results	46
4.6 Conducted Out of Band Emission Measurement.....	48
4.6.1 Limits of Conducted Out of Band Emission Measurement	48
4.6.2 Test Setup.....	48
4.6.3 Test Instruments	48
4.6.4 Test Procedure	48
4.6.5 Deviation from Test Standard	49
4.6.6 EUT Operating Condition	49
4.6.7 Test Results	49
5 Pictures of Test Arrangements.....	56
Appendix – Information on the Testing Laboratories	57



A D T

Release Control Record

Issue No.	Description	Date Issued
RF150417C34A	Original release	Jan. 25, 2016

1 Certificate of Conformity

Product: Wireless Access Point
Brand: Open Mesh
Test Model: OM5P-AC
Sample Status: Engineering Sample
Applicant: Open Mesh, Inc.
Test Date: Jan. 08 ~ Jan. 23, 2016
Standards: 47 CFR FCC Part 15, Subpart C (Section 15.247)
ANSI C63.10:2013

The above equipment has been tested by **Bureau Veritas Consumer Products Services (H.K.) Ltd., Taoyuan Branch**, and found compliance with the requirement of the above standards. The test record, data evaluation & Equipment Under Test (EUT) configurations represented herein are true and accurate accounts of the measurements of the sample's EMC characteristics under the conditions specified in this report.

Prepared by : Celine Chou , **Date:** Jan. 25, 2016
Celine Chou / Specialist

Approved by : Ken Liu , **Date:** Jan. 25, 2016
Ken Liu / Senior Manager

2 Summary of Test Results

47 CFR FCC Part 15, Subpart C (Section 15.247)			
FCC Clause	Test Item	Result	Remarks
15.207	AC Power Conducted Emission	Pass	Meet the requirement of limit. Minimum passing margin is -9.47dB at 0.32102MHz
15.205 / 15.209 / 15.247(d)	Radiated Emissions and Band Edge Measurement	Pass	Meet the requirement of limit. Minimum passing margin is -0.4dB at 2483.50MHz.
15.247(d)	Antenna Port Emission	Pass	Meet the requirement of limit.
15.247(a)(2)	6dB bandwidth	Pass	Meet the requirement of limit.
15.247(b)	Conducted power	Pass	Meet the requirement of limit.
15.247(e)	Power Spectral Density	Pass	Meet the requirement of limit.
15.203	Antenna Requirement	Pass	Antenna connector is i-pex(MHF) not a standard connector.

2.1 Measurement Uncertainty

Where relevant, the following measurement uncertainty levels have been estimated for tests performed on the EUT as specified in CISPR 16-4-2:

Measurement	Frequency	Expanded Uncertainty (k=2) (±)
Conducted Emissions at mains ports	150kHz ~ 30MHz	2.44 dB
Radiated Emissions up to 1 GHz	30MHz ~ 200MHz	3.86 dB
	200MHz ~1000MHz	3.87 dB
Radiated Emissions above 1 GHz	1GHz ~ 18GHz	2.29 dB
	18GHz ~ 40GHz	2.29 dB

2.2 Modification Record

There were no modifications required for compliance.

3 General Information

3.1 General Description of EUT

Product	Wireless Access Point
Brand	Open Mesh
Test Model	OM5P-AC
Sample Status	Engineering sample
Power Supply Rating	DC Input 12 ~ 24V 12 ~ 24Vdc from POE 48Vdc from POE
Modulation Type	CCK, DQPSK, DBPSK for DSSS 64QAM, 16QAM, QPSK, BPSK for OFDM
Modulation Technology	DSSS, OFDM
Transfer Rate	802.11b: 11.0/ 5.5/ 2.0/ 1.0Mbps 802.11g: 54.0/ 48.0/ 36.0/ 24.0/ 18.0/ 12.0/ 9.0/ 6.0Mbps 802.11n: up to 300Mbps
Operating Frequency	2412 ~ 2462MHz
Number of Channel	11 for 802.11b, 802.11g, 802.11n (20MHz) 7 for 802.11n (40MHz)
Output Power	383.730mW
Antenna Type	Refer to Note
Antenna Connector	Refer to Note
Accessory Device	N/A
Data Cable Supplied	N/A

Note:

- This report is prepared for FCC class II permissive change. The difference compared with the original report (BV ADT report no.: RF150417C34) are list as below:
 - Converting the DTS filing from 15.247 to 15.407 under new rule
 - Updating U-NII filing to under new rules
 - Changing PCB RF layout (only effect RX only) and thermal pad
 - Adding console pin
 - Changing appearance of EUT
 - Changing capacitance and resistor (for ISN LAN Port)

Therefore the EUT is re-tested in this report
- The EUT incorporates a MIMO function. Physically, the EUT provides 2 completed transmitters and 2 receivers.

Modulation Mode	TX Function
802.11b	1TX (Fixed Ant. A)
802.11g	1TX (Fixed Ant. A)
802.11n (20MHz)	2TX
802.11n (40MHz)	2TX

3. The EUT uses following antennas.

No.	Ant. Type	Connecter Type	Antenna Gain (dBi)
A	PIFA	i-pex(MHF)	2.90
B			3.38

4. In this test report, the EUT consumes power from the following adapter and POE (for support unit only).

Adapter	
Brand	DVE
Model	DSA-12PFA-09 FUS 120100
Input Power	100-240Vac, 50/60Hz, 0.5A
Output Power	12Vdc, 1A
Power Line	1.5m cable without core attached on adapter

POE	
Brand	NA
Model	APOE02-WM
Power Rating	18-24Vdc, 1A

POE's adapter	
Brand	PEC
Model	PA1024-240IB100
Input Power	100-240Vac, 50-60Hz, 0.6A
Output Power	24Vdc, 1A, 24W Max.
Power Line	1.55m cable without core attached on adapter

3.2 Description of Test Modes

11 channels are provided for 802.11b, 802.11g and 802.11n (20MHz):

Channel	Frequency	Channel	Frequency
1	2412MHz	7	2442MHz
2	2417MHz	8	2447MHz
3	2422MHz	9	2452MHz
4	2427MHz	10	2457MHz
5	2432MHz	11	2462MHz
6	2437MHz		

7 channels are provided for 802.11n (40MHz):

Channel	Frequency	Channel	Frequency
3	2422MHz	7	2442MHz
4	2427MHz	8	2447MHz
5	2432MHz	9	2452MHz
6	2437MHz		

3.2.1 Test Mode Applicability and Tested Channel Detail

EUT CONFIGURE MODE	APPLICABLE TO				DESCRIPTION
	RE≥1G	RE<1G	PLC	APCM	
A	√	√	√	√	Powered by adapter
B	-	√	√	-	Powered by POE

Where **RE≥1G**: Radiated Emission above 1GHz & Bandedge Measurement
RE<1G: Radiated Emission below 1GHz
PLC: Power Line Conducted Emission
APCM: Antenna Port Conducted Measurement

Note:

1. The EUT had been pre-tested on the positioned of each 3 axis. The worst case was found when positioned on **X-plane**.
2. "-" means no effect.

Radiated Emission Test (Above 1GHz):

- Pre-Scan has been conducted to determine the worst-case mode from all possible combinations between available modulations, data rates and antenna ports (if EUT with antenna diversity architecture).
- Following channel(s) was (were) selected for the final test as listed below.

EUT CONFIGURE MODE	MODE	AVAILABLE CHANNEL	TESTED CHANNEL	MODULATION TECHNOLOGY	MODULATION TYPE	DATA RATE (Mbps)
A	802.11b	1 to 11	1, 6, 11	DSSS	DBPSK	1.0
A	802.11g	1 to 11	1, 6, 11	OFDM	BPSK	6.0
A	802.11n (20MHz)	1 to 11	1, 6, 11	OFDM	BPSK	7.2
A	802.11n (40MHz)	3 to 9	3, 6, 9	OFDM	BPSK	15.0

Radiated Emission Test (Below 1GHz):

- Pre-Scan has been conducted to determine the worst-case mode from all possible combinations between available modulations, data rates and antenna ports (if EUT with antenna diversity architecture).
- Following channel(s) was (were) selected for the final test as listed below.

EUT CONFIGURE MODE	MODE	AVAILABLE CHANNEL	TESTED CHANNEL	MODULATION TECHNOLOGY	MODULATION TYPE	DATA RATE (Mbps)
A, B	802.11b	1 to 11	1	DSSS	DBPSK	1.0

Power Line Conducted Emission Test:

- Pre-Scan has been conducted to determine the worst-case mode from all possible combinations between available modulations, data rates and antenna ports (if EUT with antenna diversity architecture).
- Following channel(s) was (were) selected for the final test as listed below.

EUT CONFIGURE MODE	MODE	AVAILABLE CHANNEL	TESTED CHANNEL	MODULATION TECHNOLOGY	MODULATION TYPE	DATA RATE (Mbps)
A, B	802.11b	1 to 11	1	DSSS	DBPSK	1.0

Antenna Port Conducted Measurement:

- This item includes all test value of each mode, but only includes spectrum plot of worst value of each mode.
- Pre-Scan has been conducted to determine the worst-case mode from all possible combinations between available modulations, data rates and antenna ports (if EUT with antenna diversity architecture).
- Following channel(s) was (were) selected for the final test as listed below.

EUT CONFIGURE MODE	MODE	AVAILABLE CHANNEL	TESTED CHANNEL	MODULATION TECHNOLOGY	MODULATION TYPE	DATA RATE (Mbps)
A	802.11b	1 to 11	1, 6, 11	DSSS	DBPSK	1.0
A	802.11g	1 to 11	1, 6, 11	OFDM	BPSK	6.0
A	802.11n (20MHz)	1 to 11	1, 6, 11	OFDM	BPSK	7.2
A	802.11n (40MHz)	3 to 9	3, 6, 9	OFDM	BPSK	15.0

Test Condition:

APPLICABLE TO	ENVIRONMENTAL CONDITIONS	INPUT POWER (SYSTEM)	TESTED BY
RE≥1G	18deg. C, 70%RH	120Vac, 60Hz	Nick Hsu
RE<1G	20deg. C, 64%RH	120Vac, 60Hz 24Vdc	Jones Chang
PLC	19deg. C, 70%RH	120Vac, 60Hz 24Vdc	Jones Chang
APCM	24deg. C, 64%RH	120Vac, 60Hz	Match Tsui

3.3 Duty Cycle of Test Signal

802.11b: Duty cycle of test signal is > 98%, duty factor is not required.

802.11g, 802.11n (20MHz), 802.11n (40MHz): Duty cycle of test signal is < 98%, duty factor shall be considered.

802.11g: Duty cycle = $2.012/2.075 = 0.970$, Duty factor = $10 * \log(1/0.970) = 0.13$

802.11n (20MHz): Duty cycle = $1.885/1.940 = 0.972$, Duty factor = $10 * \log(1/0.972) = 0.12$

802.11n (40MHz): Duty cycle = $0.922/0.967 = 0.953$, Duty factor = $10 * \log(1/0.953) = 0.21$

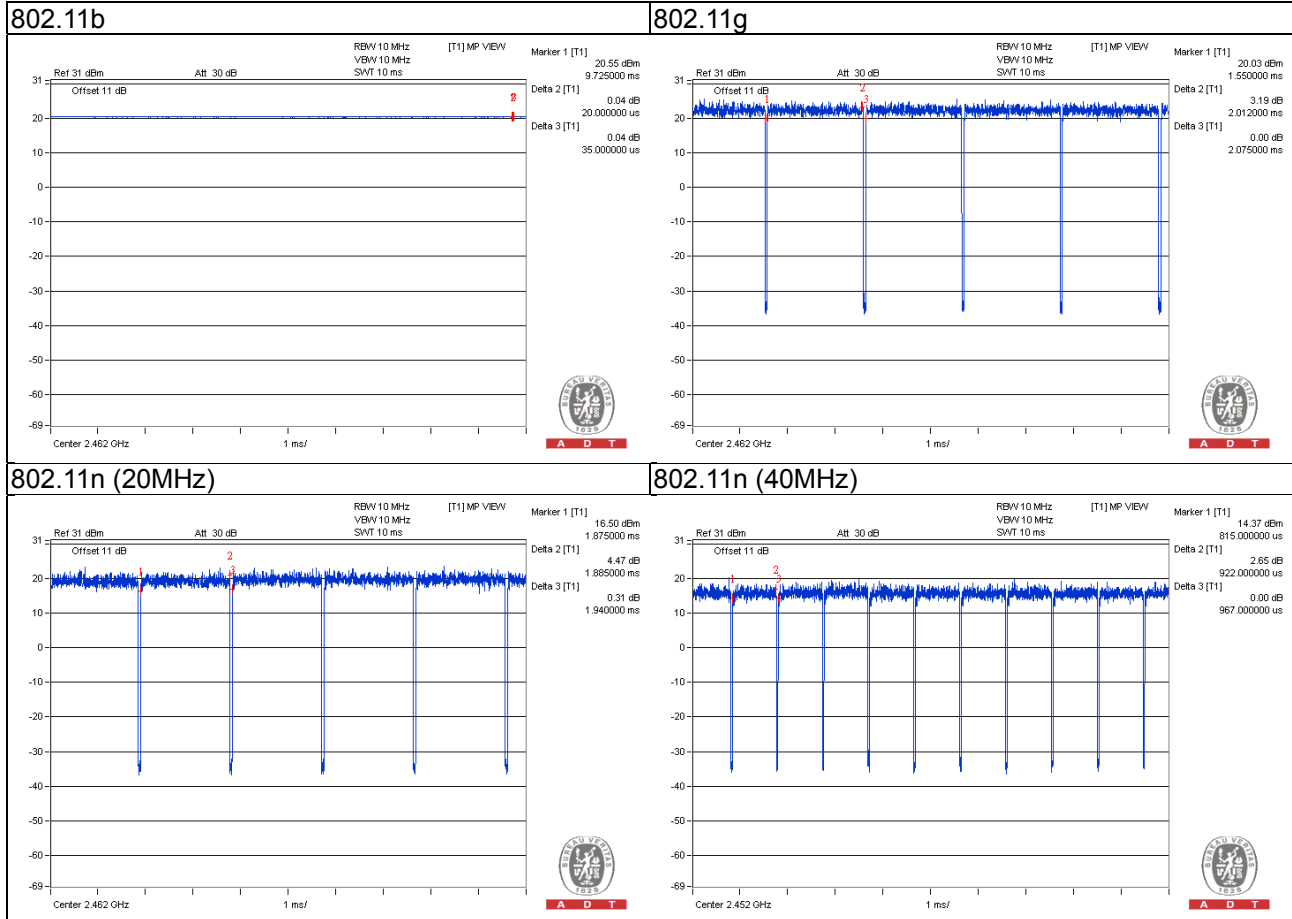

3.4 Description of Support Units

The EUT has been tested as an independent unit together with other necessary accessories or support units. The following support units or accessories were used to form a representative test configuration during the tests.

ID	Product	Brand	Model No.	Serial No.	FCC ID	Remarks
A.	Notebook	DELL	E5410	1HC2XM1	FCC DoC Approved	-
B.	Adapter	DVE	DSA-12PFA-09 FUS 120100	NA	NA	For test mode A only Provided by Manufacturer
C.	POE	NA	APOE02-WM	NA	NA	For test mode B only Provided by Manufacturer
D.	POE's Adapter	PEC	PA1024-240IB100	NA	NA	For test mode B only Provided by Manufacturer
E.	Load	NA	NA	NA	NA	-

Note:

1. All power cords of the above support units are non-shielded (1.8m).
2. Item A acted as communication partners to transfer data.

ID	Descriptions	Qty.	Length (m)	Shielding (Yes/No)	Cores (Qty.)	Remarks
1.	RJ45	1	3	N	0	-
2.	Power	1	1.5	N	0	For test mode A only Attached on adapter
		1	1.55	N	0	For test mode B only Attached on adapter
3.	RJ45	1	1.8	N	0	-
4.	RJ45	1	1.8	N	0	-

3.4.1 Configuration of System under Test

Test Mode A

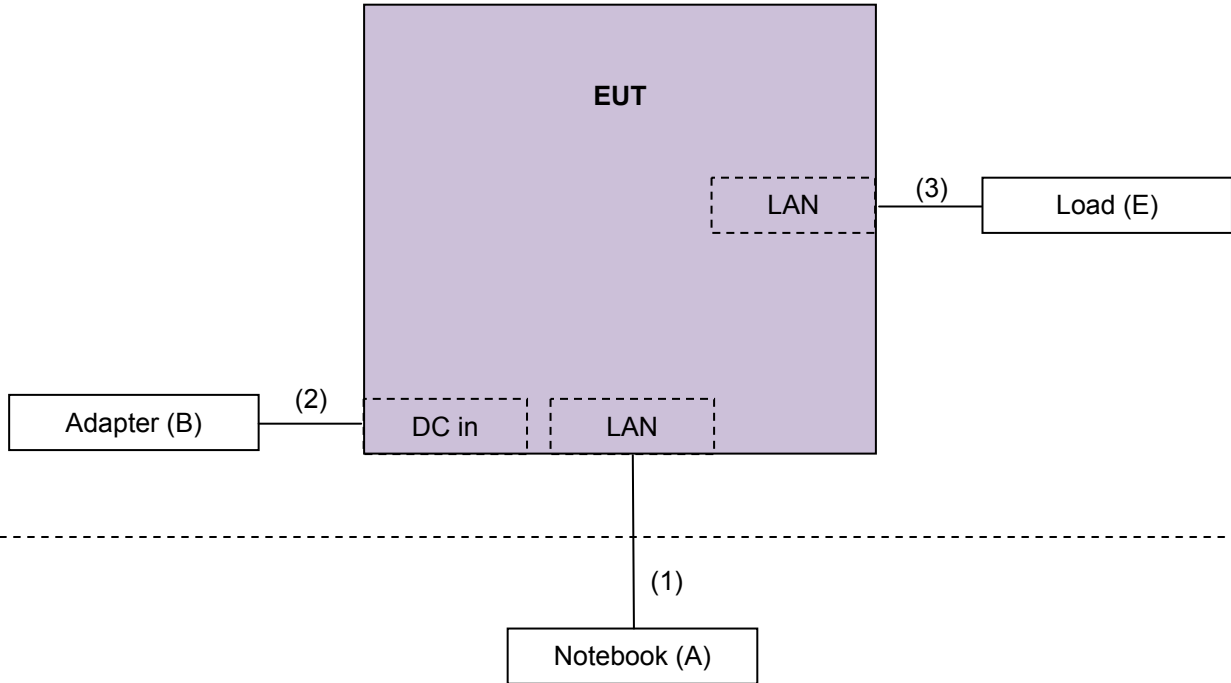

Test Mode B

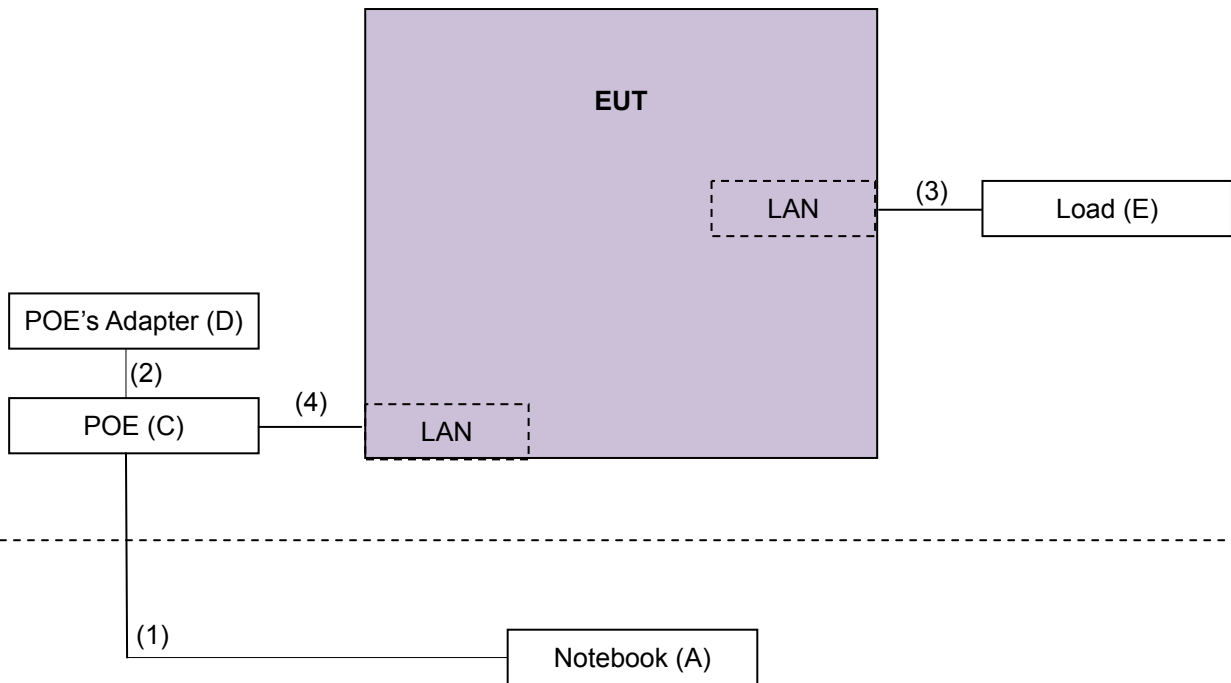

3.5 General Description of Applied Standards

The EUT is a RF Product. According to the specifications of the manufacturer, it must comply with the requirements of the following standards:

FCC Part 15, Subpart C (15.247)

558074 D01 DTS Meas Guidance v03r04

662911 D01 Multiple Transmitter Output v02r01

ANSI C63.10-2013

All test items have been performed and recorded as per the above standards.

Note: The EUT is also considered as a kind of computer peripheral, because the connection to computer is necessary for typical use. It has been verified to comply with the requirements of FCC Part 15, Subpart B, Class B (DoC). The test report has been issued separately.

4 Test Types and Results

4.1 Radiated Emission and Bandedge Measurement

4.1.1 Limits of Radiated Emission and Bandedge Measurement

Radiated emissions which fall in the restricted bands must comply with the radiated emission limits specified as below table. Other emissions shall be at least 30dB below the highest level of the desired power:

Frequencies (MHz)	Field Strength (microvolts/meter)	Measurement Distance (meters)
0.009 ~ 0.490	2400/F(kHz)	300
0.490 ~ 1.705	24000/F(kHz)	30
1.705 ~ 30.0	30	30
30 ~ 88	100	3
88 ~ 216	150	3
216 ~ 960	200	3
Above 960	500	3

Note:

1. The lower limit shall apply at the transition frequencies.
2. Emission level (dBuV/m) = 20 log Emission level (uV/m).
3. For frequencies above 1000MHz, the field strength limits are based on average detector, however, the peak field strength of any emission shall not exceed the maximum permitted average limits, specified above by more than 30dB under any condition of modulation.

4.1.2 Test Instruments

Description & Manufacturer	Model No.	Serial No.	Cal. Date	Cal. Due
Test Receiver ROHDE & SCHWARZ	ESIB7	100187	Apr. 10, 2015	Apr. 09, 2016
Spectrum Analyzer ROHDE & SCHWARZ	FSP40	100041	Sep. 02, 2015	Sep. 01, 2016
BILOG Antenna SCHWARZBECK	VULB9168	9168-151	Jan. 07, 2016	Jan. 06, 2017
HORN Antenna SCHWARZBECK	9120D	209	Jan. 20, 2015	Jan. 19, 2016
			Jan. 20, 2016	Jan. 19, 2017
HORN Antenna SCHWARZBECK	BBHA 9170	BBHA9170241	Jan. 18, 2015	Jan. 17, 2016
			Jan. 18, 2016	Jan. 17, 2017
Preamplifier Agilent	8447D	2944A10738	Oct. 18, 2015	Oct. 17, 2016
Preamplifier Agilent	8449B	3008A01964	Aug. 22, 2015	Aug. 21, 2016
RF signal cable HUBER+SUHNER	SUCOFLEX 104	Cable-CH3-03 (214378)	Aug. 22, 2015	Aug. 21, 2016
RF signal cable HUBER+SUHNER	SUCOFLEX 106	Cable-CH3-03 (309224+12738)	Aug. 22, 2015	Aug. 21, 2016
Software BV ADT	ADT_Radiated_ V7.6.15.9.4	NA	NA	NA
Antenna Tower inn-co GmbH	MA 4000	013303	NA	NA
Antenna Tower Controller BV ADT	AT100	AT93021702	NA	NA
Turn Table BV ADT	TT100	TT93021702	NA	NA
Turn Table Controller BV ADT	SC100	SC93021702	NA	NA
High Speed Peak Power Meter	ML2495A	0824011	Jul. 09, 2015	Jul. 08, 2016
Power Sensor	MA2411B	0738171	Jul. 09, 2015	Jul. 08, 2016

- Note:
1. The calibration interval of the above test instruments is 12 months and the calibrations are traceable to NML/ROC and NIST/USA.
 2. The test was performed in HwaYa Chamber 3.
 3. The horn antenna and preamplifier (model: 8449B) are used only for the measurement of emission frequency above 1GHz if tested.
 4. The FCC Site Registration No. is 988962.
 5. The IC Site Registration No. is IC 7450F-3.

4.1.3 Test Procedures

- a. The EUT was placed on the top of a rotating table 0.8 meters (for below 1GHz) / 1.5 meters (for above 1GHz) above the ground at 3 meter chamber room for test. The table was rotated 360 degrees to determine the position of the highest radiation.
- b. The EUT was set 3 meters away from the interference-receiving antenna, which was mounted on the top of a variable-height antenna tower.
- c. The height of antenna is varied from one meter to four meters above the ground to determine the maximum value of the field strength. Both horizontal and vertical polarizations of the antenna are set to make the measurement.
- d. For each suspected emission, the EUT was arranged to its worst case and then the antenna was tuned to heights from 1 meter to 4 meters and the rotatable table was turned from 0 degrees to 360 degrees to find the maximum reading.
- e. The test-receiver system was set to quasi-peak detect function and specified bandwidth with maximum hold mode when the test frequency is below 1 GHz.
- f. The test-receiver system was set to peak and average detect function and specified bandwidth with maximum hold mode when the test frequency is above 1 GHz. If the peak reading value also meets average limit, measurement with the average detector is unnecessary.

Note:

1. The resolution bandwidth and video bandwidth of test receiver/spectrum analyzer is 120kHz for Quasi-peak detection (QP) at frequency below 1GHz.
2. The resolution bandwidth of test receiver/spectrum analyzer is 1 MHz and the video bandwidth is 3 MHz for Peak detection (PK) at frequency above 1GHz.
3. The resolution bandwidth of test receiver/spectrum analyzer is 1MHz and the video bandwidth is 3MHz for RMS Average (Duty cycle < 98%) for Average detection (AV) at frequency above 1GHz, then the measurement results was added to a correction factor ($10 \log(1/\text{duty cycle})$).
4. The resolution bandwidth of test receiver/spectrum analyzer is 1MHz and the video bandwidth is 10Hz (Duty cycle $\geq 98\%$) for Average detection (AV) at frequency above 1GHz.
5. All modes of operation were investigated and the worst-case emissions are reported.

4.1.4 Deviation from Test Standard

No deviation.

4.1.5 Test Set Up

<Frequency Range below 1GHz>

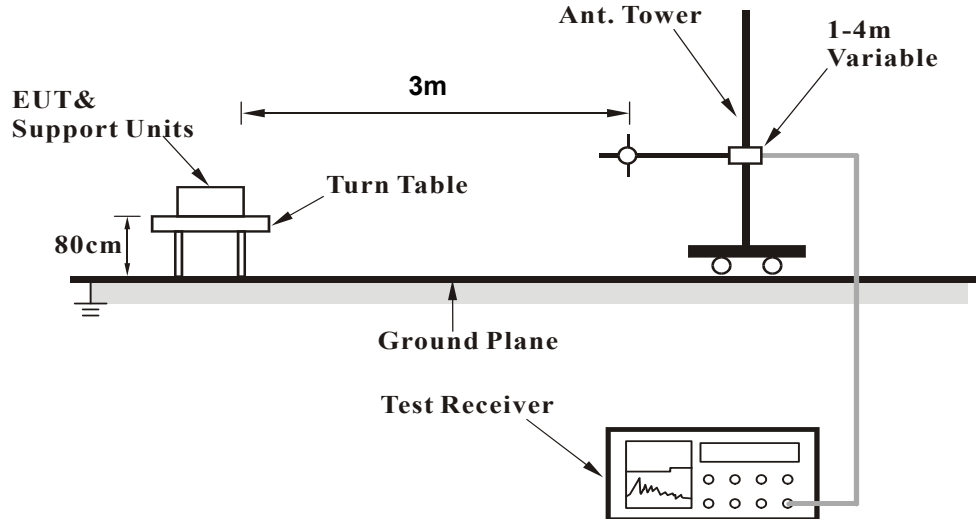

<Frequency Range above 1GHz>

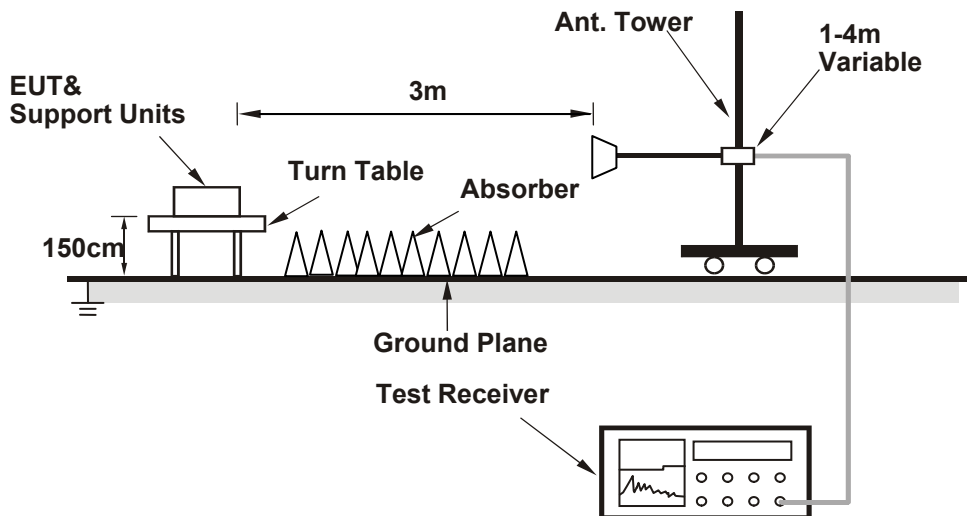

For the actual test configuration, please refer to the attached file (Test Setup Photo).

4.1.6 EUT Operating Conditions

- a. Placed the EUT on the testing table.
- b. Prepared a notebook to act as communication partner and placed it outside of testing area.
- c. The communication partner connected with EUT via a RJ45 cable and ran a test program (provided by manufacturer) to enable EUT under transmission condition continuously at specific channel frequency.
- d. The communication partner sent data to EUT by command "PING".

4.1.7 Test Results

Above 1GHz worst-case data:

802.11b

CHANNEL	TX Channel 1	DETECTOR	Peak (PK)
FREQUENCY RANGE	1GHz ~ 25GHz	FUNCTION	Average (AV)

ANTENNA POLARITY & TEST DISTANCE: HORIZONTAL AT 3 M

NO.	FREQ. (MHz)	EMISSION LEVEL (dBuV/m)	LIMIT (dBuV/m)	MARGIN (dB)	ANTENNA HEIGHT (m)	TABLE ANGLE (Degree)	RAW VALUE (dBuV)	CORRECTION FACTOR (dB/m)
1	2390.00	56.5 PK	74.0	-17.5	1.68 H	0	24.00	32.50
2	2390.00	44.7 AV	54.0	-9.3	1.68 H	0	12.20	32.50
3	*2412.00	100.6 PK			1.86 H	18	68.00	32.60
4	*2412.00	96.7 AV			1.86 H	18	64.10	32.60
5	4824.00	53.5 PK	74.0	-20.5	2.71 H	124	47.40	6.10
6	4824.00	48.4 AV	54.0	-5.6	2.71 H	124	42.30	6.10

ANTENNA POLARITY & TEST DISTANCE: VERTICAL AT 3 M

NO.	FREQ. (MHz)	EMISSION LEVEL (dBuV/m)	LIMIT (dBuV/m)	MARGIN (dB)	ANTENNA HEIGHT (m)	TABLE ANGLE (Degree)	RAW VALUE (dBuV)	CORRECTION FACTOR (dB/m)
1	2390.00	56.5 PK	74.0	-17.5	1.61 V	305	24.00	32.50
2	2390.00	44.8 AV	54.0	-9.2	1.61 V	305	12.30	32.50
3	*2412.00	101.9 PK			1.63 V	293	69.30	32.60
4	*2412.00	98.1 AV			1.63 V	293	65.50	32.60
5	4824.00	54.2 PK	74.0	-19.8	1.15 V	235	48.10	6.10
6	4824.00	49.7 AV	54.0	-4.3	1.15 V	235	43.60	6.10

Remarks:

1. Emission Level(dBuV/m) = Raw Value(dBuV) + Correction Factor(dB/m)
2. Correction Factor(dB/m) = Antenna Factor(dB/m) + Cable Factor(dB)
3. The other emission levels were very low against the limit.
4. Margin value = Emission Level – Limit value
5. " * ": Fundamental frequency.

CHANNEL	TX Channel 6	DETECTOR FUNCTION	Peak (PK)
FREQUENCY RANGE	1GHz ~ 25GHz		Average (AV)

ANTENNA POLARITY & TEST DISTANCE: HORIZONTAL AT 3 M

NO.	FREQ. (MHz)	EMISSION LEVEL (dBuV/m)	LIMIT (dBuV/m)	MARGIN (dB)	ANTENNA HEIGHT (m)	TABLE ANGLE (Degree)	RAW VALUE (dBuV)	CORRECTION FACTOR (dB/m)
1	*2437.00	101.0 PK			2.12 H	20	68.30	32.70
2	*2437.00	97.3 AV			2.12 H	20	64.60	32.70
3	4874.00	52.6 PK	74.0	-21.4	3.35 H	52	46.40	6.20
4	4874.00	47.6 AV	54.0	-6.4	3.35 H	52	41.40	6.20

ANTENNA POLARITY & TEST DISTANCE: VERTICAL AT 3 M

NO.	FREQ. (MHz)	EMISSION LEVEL (dBuV/m)	LIMIT (dBuV/m)	MARGIN (dB)	ANTENNA HEIGHT (m)	TABLE ANGLE (Degree)	RAW VALUE (dBuV)	CORRECTION FACTOR (dB/m)
1	*2437.00	100.7 PK			1.00 V	271	68.00	32.70
2	*2437.00	97.4 AV			1.00 V	271	64.70	32.70
3	4874.00	53.2 PK	74.0	-20.8	1.09 V	241	47.00	6.20
4	4874.00	48.4 AV	54.0	-5.6	1.09 V	241	42.20	6.20

Remarks:

1. Emission Level(dBuV/m) = Raw Value(dBuV) + Correction Factor(dB/m)
2. Correction Factor(dB/m) = Antenna Factor(dB/m) + Cable Factor(dB)
3. The other emission levels were very low against the limit.
4. Margin value = Emission Level – Limit value
5. " * ": Fundamental frequency.

CHANNEL	TX Channel 11	DETECTOR FUNCTION	Peak (PK)
FREQUENCY RANGE	1GHz ~ 25GHz		Average (AV)

ANTENNA POLARITY & TEST DISTANCE: HORIZONTAL AT 3 M

NO.	FREQ. (MHz)	EMISSION LEVEL (dBuV/m)	LIMIT (dBuV/m)	MARGIN (dB)	ANTENNA HEIGHT (m)	TABLE ANGLE (Degree)	RAW VALUE (dBuV)	CORRECTION FACTOR (dB/m)
1	*2462.00	98.3 PK			1.00 H	187	65.70	32.60
2	*2462.00	95.1 AV			1.00 H	187	62.50	32.60
3	2483.50	56.1 PK	74.0	-17.9	1.15 H	237	23.40	32.70
4	2483.50	44.9 AV	54.0	-9.1	1.15 H	237	12.20	32.70
5	4924.00	52.3 PK	74.0	-21.7	3.39 H	220	46.00	6.30
6	4924.00	46.8 AV	54.0	-7.2	3.39 H	220	40.50	6.30

ANTENNA POLARITY & TEST DISTANCE: VERTICAL AT 3 M

NO.	FREQ. (MHz)	EMISSION LEVEL (dBuV/m)	LIMIT (dBuV/m)	MARGIN (dB)	ANTENNA HEIGHT (m)	TABLE ANGLE (Degree)	RAW VALUE (dBuV)	CORRECTION FACTOR (dB/m)
1	*2462.00	100.0 PK			1.34 V	273	67.40	32.60
2	*2462.00	96.2 AV			1.34 V	273	63.60	32.60
3	2483.50	55.8 PK	74.0	-18.2	1.29 V	295	23.10	32.70
4	2483.50	45.0 AV	54.0	-9.0	1.29 V	295	12.30	32.70
5	4924.00	51.8 PK	74.0	-22.2	1.43 V	233	45.50	6.30
6	4924.00	46.1 AV	54.0	-7.9	1.43 V	233	39.80	6.30

Remarks:

1. Emission Level(dBuV/m) = Raw Value(dBuV) + Correction Factor(dB/m)
2. Correction Factor(dB/m) = Antenna Factor(dB/m) + Cable Factor(dB)
3. The other emission levels were very low against the limit.
4. Margin value = Emission Level – Limit value
5. " * ": Fundamental frequency.

802.11g

CHANNEL	TX Channel 1	DETECTOR FUNCTION	Peak (PK)
FREQUENCY RANGE	1GHz ~ 25GHz		Average (AV)

ANTENNA POLARITY & TEST DISTANCE: HORIZONTAL AT 3 M

NO.	FREQ. (MHz)	EMISSION LEVEL (dBuV/m)	LIMIT (dBuV/m)	MARGIN (dB)	ANTENNA HEIGHT (m)	TABLE ANGLE (Degree)	RAW VALUE (dBuV)	CORRECTION FACTOR (dB/m)
1	2390.00	64.5 PK	74.0	-9.5	2.38 H	337	32.00	32.50
2	2390.00	48.8 AV	54.0	-5.2	2.38 H	337	16.30	32.50
3	*2412.00	99.4 PK			1.00 H	20	66.80	32.60
4	*2412.00	90.4 AV			1.00 H	20	57.80	32.60
5	4824.00	50.8 PK	74.0	-23.2	3.00 H	59	44.70	6.10
6	4824.00	37.5 AV	54.0	-16.5	3.00 H	59	31.40	6.10

ANTENNA POLARITY & TEST DISTANCE: VERTICAL AT 3 M

NO.	FREQ. (MHz)	EMISSION LEVEL (dBuV/m)	LIMIT (dBuV/m)	MARGIN (dB)	ANTENNA HEIGHT (m)	TABLE ANGLE (Degree)	RAW VALUE (dBuV)	CORRECTION FACTOR (dB/m)
1	2390.00	63.7 PK	74.0	-10.3	1.71 V	275	31.20	32.50
2	2390.00	49.4 AV	54.0	-4.6	1.71 V	275	16.90	32.50
3	*2412.00	101.4 PK			1.10 V	270	68.80	32.60
4	*2412.00	90.7 AV			1.10 V	270	58.10	32.60
5	4824.00	49.4 PK	74.0	-24.6	1.27 V	227	43.30	6.10
6	4824.00	37.9 AV	54.0	-16.1	1.27 V	227	31.80	6.10

Remarks:

1. Emission Level(dBuV/m) = Raw Value(dBuV) + Correction Factor(dB/m)
2. Correction Factor(dB/m) = Antenna Factor(dB/m) + Cable Factor(dB)
3. The other emission levels were very low against the limit.
4. Margin value = Emission Level – Limit value
5. " * ": Fundamental frequency.

CHANNEL	TX Channel 6	DETECTOR FUNCTION	Peak (PK)
FREQUENCY RANGE	1GHz ~ 25GHz		Average (AV)

ANTENNA POLARITY & TEST DISTANCE: HORIZONTAL AT 3 M

NO.	FREQ. (MHz)	EMISSION LEVEL (dBuV/m)	LIMIT (dBuV/m)	MARGIN (dB)	ANTENNA HEIGHT (m)	TABLE ANGLE (Degree)	RAW VALUE (dBuV)	CORRECTION FACTOR (dB/m)
1	*2437.00	105.8 PK			1.00 H	27	73.10	32.70
2	*2437.00	96.2 AV			1.00 H	27	63.50	32.70
3	4874.00	54.9 PK	74.0	-19.1	1.34 H	311	48.70	6.20
4	4874.00	41.7 AV	54.0	-12.3	1.34 H	311	35.50	6.20

ANTENNA POLARITY & TEST DISTANCE: VERTICAL AT 3 M

NO.	FREQ. (MHz)	EMISSION LEVEL (dBuV/m)	LIMIT (dBuV/m)	MARGIN (dB)	ANTENNA HEIGHT (m)	TABLE ANGLE (Degree)	RAW VALUE (dBuV)	CORRECTION FACTOR (dB/m)
1	*2437.00	107.1 PK			1.00 V	277	74.40	32.70
2	*2437.00	96.8 AV			1.00 V	277	64.10	32.70
3	4874.00	62.4 PK	74.0	-11.6	1.08 V	259	56.20	6.20
4	4874.00	48.8 AV	54.0	-5.2	1.08 V	259	42.60	6.20

Remarks:

1. Emission Level(dBuV/m) = Raw Value(dBuV) + Correction Factor(dB/m)
2. Correction Factor(dB/m) = Antenna Factor(dB/m) + Cable Factor(dB)
3. The other emission levels were very low against the limit.
4. Margin value = Emission Level – Limit value
5. " * ": Fundamental frequency.

CHANNEL	TX Channel 11	DETECTOR FUNCTION	Peak (PK)
FREQUENCY RANGE	1GHz ~ 25GHz		Average (AV)

ANTENNA POLARITY & TEST DISTANCE: HORIZONTAL AT 3 M								
NO.	FREQ. (MHz)	EMISSION LEVEL (dBuV/m)	LIMIT (dBuV/m)	MARGIN (dB)	ANTENNA HEIGHT (m)	TABLE ANGLE (Degree)	RAW VALUE (dBuV)	CORRECTION FACTOR (dB/m)
1	*2462.00	101.0 PK			1.59 H	187	68.40	32.60
2	*2462.00	91.1 AV			1.59 H	187	58.50	32.60
3	2483.50	67.2 PK	74.0	-6.8	1.94 H	188	34.50	32.70
4	2483.50	49.7 AV	54.0	-4.3	1.94 H	188	17.00	32.70
5	4924.00	49.0 PK	74.0	-25.0	2.39 H	331	42.70	6.30
6	4924.00	35.5 AV	54.0	-18.5	2.39 H	331	29.20	6.30
ANTENNA POLARITY & TEST DISTANCE: VERTICAL AT 3 M								
NO.	FREQ. (MHz)	EMISSION LEVEL (dBuV/m)	LIMIT (dBuV/m)	MARGIN (dB)	ANTENNA HEIGHT (m)	TABLE ANGLE (Degree)	RAW VALUE (dBuV)	CORRECTION FACTOR (dB/m)
1	*2462.00	102.9 PK			1.15 V	282	70.30	32.60
2	*2462.00	92.8 AV			1.15 V	282	60.20	32.60
3	2483.50	69.1 PK	74.0	-4.9	1.32 V	297	36.40	32.70
4	2483.50	51.6 AV	54.0	-2.4	1.32 V	297	18.90	32.70
5	4924.00	52.1 PK	74.0	-21.9	1.47 V	259	45.80	6.30
6	4924.00	38.2 AV	54.0	-15.8	1.47 V	259	31.90	6.30

Remarks:

1. Emission Level(dBuV/m) = Raw Value(dBuV) + Correction Factor(dB/m)
2. Correction Factor(dB/m) = Antenna Factor(dB/m) + Cable Factor(dB)
3. The other emission levels were very low against the limit.
4. Margin value = Emission Level – Limit value
5. " * ": Fundamental frequency.

802.11n (20MHz)

CHANNEL	TX Channel 1	DETECTOR FUNCTION	Peak (PK)
FREQUENCY RANGE	1GHz ~ 25GHz		Average (AV)

ANTENNA POLARITY & TEST DISTANCE: HORIZONTAL AT 3 M

NO.	FREQ. (MHz)	EMISSION LEVEL (dBuV/m)	LIMIT (dBuV/m)	MARGIN (dB)	ANTENNA HEIGHT (m)	TABLE ANGLE (Degree)	RAW VALUE (dBuV)	CORRECTION FACTOR (dB/m)
1	2390.00	63.7 PK	74.0	-10.3	2.11 H	98	31.20	32.50
2	2390.00	48.9 AV	54.0	-5.1	2.11 H	98	16.40	32.50
3	*2412.00	105.3 PK			2.09 H	101	72.70	32.60
4	*2412.00	95.4 AV			2.09 H	101	62.80	32.60
5	4824.00	47.6 PK	74.0	-26.4	1.58 H	318	41.50	6.10
6	4824.00	35.1 AV	54.0	-18.9	1.58 H	318	29.00	6.10

ANTENNA POLARITY & TEST DISTANCE: VERTICAL AT 3 M

NO.	FREQ. (MHz)	EMISSION LEVEL (dBuV/m)	LIMIT (dBuV/m)	MARGIN (dB)	ANTENNA HEIGHT (m)	TABLE ANGLE (Degree)	RAW VALUE (dBuV)	CORRECTION FACTOR (dB/m)
1	2390.00	68.0 PK	74.0	-6.0	1.00 V	234	35.50	32.50
2	2390.00	50.8 AV	54.0	-3.2	1.00 V	234	18.30	32.50
3	*2412.00	102.9 PK			1.00 V	232	70.30	32.60
4	*2412.00	93.3 AV			1.00 V	232	60.70	32.60
5	4824.00	51.5 PK	74.0	-22.5	1.12 V	234	45.40	6.10
6	4824.00	38.2 AV	54.0	-15.8	1.12 V	234	32.10	6.10

Remarks:

1. Emission Level(dBuV/m) = Raw Value(dBuV) + Correction Factor(dB/m)
2. Correction Factor(dB/m) = Antenna Factor(dB/m) + Cable Factor(dB)
3. The other emission levels were very low against the limit.
4. Margin value = Emission Level – Limit value
5. " * ": Fundamental frequency.

CHANNEL	TX Channel 6	DETECTOR FUNCTION	Peak (PK)
FREQUENCY RANGE	1GHz ~ 25GHz		Average (AV)

ANTENNA POLARITY & TEST DISTANCE: HORIZONTAL AT 3 M

NO.	FREQ. (MHz)	EMISSION LEVEL (dBuV/m)	LIMIT (dBuV/m)	MARGIN (dB)	ANTENNA HEIGHT (m)	TABLE ANGLE (Degree)	RAW VALUE (dBuV)	CORRECTION FACTOR (dB/m)
1	2390.00	64.5 PK	74.0	-9.5	1.50 H	99	32.00	32.50
2	2390.00	50.4 AV	54.0	-3.6	1.50 H	99	17.90	32.50
3	*2437.00	112.7 PK			1.00 H	102	80.00	32.70
4	*2437.00	103.2 AV			1.00 H	102	70.50	32.70
5	2483.50	66.3 PK	74.0	-7.7	1.98 H	357	33.60	32.70
6	2483.50	51.2 AV	54.0	-2.8	1.98 H	357	18.50	32.70
7	4874.00	61.5 PK	74.0	-12.5	1.55 H	19	55.30	6.20
8	4874.00	47.3 AV	54.0	-6.7	1.55 H	19	41.10	6.20

ANTENNA POLARITY & TEST DISTANCE: VERTICAL AT 3 M

NO.	FREQ. (MHz)	EMISSION LEVEL (dBuV/m)	LIMIT (dBuV/m)	MARGIN (dB)	ANTENNA HEIGHT (m)	TABLE ANGLE (Degree)	RAW VALUE (dBuV)	CORRECTION FACTOR (dB/m)
1	2390.00	70.8 PK	74.0	-3.2	2.30 V	297	38.30	32.50
2	2390.00	51.8 AV	54.0	-2.2	2.30 V	297	19.30	32.50
3	*2437.00	114.3 PK			1.54 V	294	81.60	32.70
4	*2437.00	104.3 AV			1.54 V	294	71.60	32.70
5	2483.50	73.3 PK	74.0	-0.7	2.28 V	333	40.60	32.70
6	2483.50	53.6 AV	54.0	-0.4	2.28 V	333	20.90	32.70
7	4874.00	65.5 PK	74.0	-8.5	2.10 V	304	59.30	6.20
8	4874.00	51.8 AV	54.0	-2.2	2.10 V	304	45.60	6.20

Remarks:

1. Emission Level(dBuV/m) = Raw Value(dBuV) + Correction Factor(dB/m)
2. Correction Factor(dB/m) = Antenna Factor(dB/m) + Cable Factor(dB)
3. The other emission levels were very low against the limit.
4. Margin value = Emission Level – Limit value
5. " * ": Fundamental frequency.

CHANNEL	TX Channel 11	DETECTOR FUNCTION	Peak (PK)
FREQUENCY RANGE	1GHz ~ 25GHz		Average (AV)

ANTENNA POLARITY & TEST DISTANCE: HORIZONTAL AT 3 M

NO.	FREQ. (MHz)	EMISSION LEVEL (dBuV/m)	LIMIT (dBuV/m)	MARGIN (dB)	ANTENNA HEIGHT (m)	TABLE ANGLE (Degree)	RAW VALUE (dBuV)	CORRECTION FACTOR (dB/m)
1	*2462.00	104.9 PK			1.36 H	103	72.30	32.60
2	*2462.00	94.8 AV			1.36 H	103	62.20	32.60
3	2483.50	71.2 PK	74.0	-2.8	1.53 H	104	38.50	32.70
4	2483.50	49.7 AV	54.0	-4.3	1.53 H	104	17.00	32.70
5	4924.00	47.7 PK	74.0	-26.3	1.55 H	345	41.40	6.30
6	4924.00	35.4 AV	54.0	-18.6	1.55 H	345	29.10	6.30

ANTENNA POLARITY & TEST DISTANCE: VERTICAL AT 3 M

NO.	FREQ. (MHz)	EMISSION LEVEL (dBuV/m)	LIMIT (dBuV/m)	MARGIN (dB)	ANTENNA HEIGHT (m)	TABLE ANGLE (Degree)	RAW VALUE (dBuV)	CORRECTION FACTOR (dB/m)
1	*2462.00	104.7 PK			3.18 V	171	72.10	32.60
2	*2462.00	94.9 AV			3.18 V	171	62.30	32.60
3	2483.50	68.0 PK	74.0	-6.0	2.74 V	184	35.30	32.70
4	2483.50	50.7 AV	54.0	-3.3	2.74 V	184	18.00	32.70
5	4924.00	50.7 PK	74.0	-23.3	2.12 V	326	44.40	6.30
6	4924.00	37.9 AV	54.0	-16.1	2.12 V	326	31.60	6.30

Remarks:

1. Emission Level(dBuV/m) = Raw Value(dBuV) + Correction Factor(dB/m)
2. Correction Factor(dB/m) = Antenna Factor(dB/m) + Cable Factor(dB)
3. The other emission levels were very low against the limit.
4. Margin value = Emission Level – Limit value
5. " * ": Fundamental frequency.

802.11n (40MHz)

CHANNEL	TX Channel 3	DETECTOR FUNCTION	Peak (PK) Average (AV)
FREQUENCY RANGE	1GHz ~ 25GHz		

ANTENNA POLARITY & TEST DISTANCE: HORIZONTAL AT 3 M

NO.	FREQ. (MHz)	EMISSION LEVEL (dBuV/m)	LIMIT (dBuV/m)	MARGIN (dB)	ANTENNA HEIGHT (m)	TABLE ANGLE (Degree)	RAW VALUE (dBuV)	CORRECTION FACTOR (dB/m)
1	2390.00	67.7 PK	74.0	-6.3	2.11 H	97	35.20	32.50
2	2390.00	50.1 AV	54.0	-3.9	2.11 H	97	17.60	32.50
3	*2422.00	100.2 PK			2.34 H	104	67.60	32.60
4	*2422.00	91.6 AV			2.34 H	104	59.00	32.60
5	4844.00	47.2 PK	74.0	-26.8	1.87 H	98	41.10	6.10
6	4844.00	35.0 AV	54.0	-19.0	1.87 H	98	28.90	6.10

ANTENNA POLARITY & TEST DISTANCE: VERTICAL AT 3 M

NO.	FREQ. (MHz)	EMISSION LEVEL (dBuV/m)	LIMIT (dBuV/m)	MARGIN (dB)	ANTENNA HEIGHT (m)	TABLE ANGLE (Degree)	RAW VALUE (dBuV)	CORRECTION FACTOR (dB/m)
1	2390.00	66.4 PK	74.0	-7.6	1.60 V	68	33.90	32.50
2	2390.00	49.6 AV	54.0	-4.4	1.60 V	68	17.10	32.50
3	*2422.00	98.7 PK			1.35 V	69	66.10	32.60
4	*2422.00	89.9 AV			1.35 V	69	57.30	32.60
5	4844.00	47.0 PK	74.0	-27.0	1.54 V	54	40.90	6.10
6	4844.00	34.8 AV	54.0	-19.2	1.54 V	54	28.70	6.10

Remarks:

1. Emission Level(dBuV/m) = Raw Value(dBuV) + Correction Factor(dB/m)
2. Correction Factor(dB/m) = Antenna Factor(dB/m) + Cable Factor(dB)
3. The other emission levels were very low against the limit.
4. Margin value = Emission Level – Limit value
5. " * ": Fundamental frequency.

CHANNEL	TX Channel 6	DETECTOR FUNCTION	Peak (PK)
FREQUENCY RANGE	1GHz ~ 25GHz		Average (AV)

ANTENNA POLARITY & TEST DISTANCE: HORIZONTAL AT 3 M

NO.	FREQ. (MHz)	EMISSION LEVEL (dBuV/m)	LIMIT (dBuV/m)	MARGIN (dB)	ANTENNA HEIGHT (m)	TABLE ANGLE (Degree)	RAW VALUE (dBuV)	CORRECTION FACTOR (dB/m)
1	*2437.00	102.0 PK			1.00 H	106	69.30	32.70
2	*2437.00	93.6 AV			1.00 H	106	60.90	32.70
3	2483.50	65.2 PK	74.0	-8.8	1.07 H	98	32.50	32.70
4	2483.50	48.7 AV	54.0	-5.3	1.07 H	98	16.00	32.70
5	4874.00	47.9 PK	74.0	-26.1	1.20 H	84	41.70	6.20
6	4874.00	35.5 AV	54.0	-18.5	1.20 H	84	29.30	6.20

ANTENNA POLARITY & TEST DISTANCE: VERTICAL AT 3 M

NO.	FREQ. (MHz)	EMISSION LEVEL (dBuV/m)	LIMIT (dBuV/m)	MARGIN (dB)	ANTENNA HEIGHT (m)	TABLE ANGLE (Degree)	RAW VALUE (dBuV)	CORRECTION FACTOR (dB/m)
1	*2437.00	101.7 PK			1.00 V	165	69.00	32.70
2	*2437.00	92.7 AV			1.00 V	165	60.00	32.70
3	2483.50	66.9 PK	74.0	-7.1	1.00 V	140	34.20	32.70
4	2483.50	49.3 AV	54.0	-4.7	1.00 V	140	16.60	32.70
5	4874.00	47.9 PK	74.0	-26.1	1.09 V	108	41.70	6.20
6	4874.00	36.1 AV	54.0	-17.9	1.09 V	108	29.90	6.20

Remarks:

1. Emission Level(dBuV/m) = Raw Value(dBuV) + Correction Factor(dB/m)
2. Correction Factor(dB/m) = Antenna Factor(dB/m) + Cable Factor(dB)
3. The other emission levels were very low against the limit.
4. Margin value = Emission Level – Limit value
5. " * ": Fundamental frequency.

CHANNEL	TX Channel 9	DETECTOR FUNCTION	Peak (PK)
FREQUENCY RANGE	1GHz ~ 25GHz		Average (AV)

ANTENNA POLARITY & TEST DISTANCE: HORIZONTAL AT 3 M

NO.	FREQ. (MHz)	EMISSION LEVEL (dBuV/m)	LIMIT (dBuV/m)	MARGIN (dB)	ANTENNA HEIGHT (m)	TABLE ANGLE (Degree)	RAW VALUE (dBuV)	CORRECTION FACTOR (dB/m)
1	*2452.00	99.9 PK			1.00 H	105	67.20	32.70
2	*2452.00	91.3 AV			1.00 H	105	58.60	32.70
3	2483.50	65.6 PK	74.0	-8.4	1.01 H	62	32.90	32.70
4	2483.50	49.2 AV	54.0	-4.8	1.01 H	62	16.50	32.70
5	4904.00	47.1 PK	74.0	-26.9	1.28 H	112	41.00	6.10
6	4904.00	35.5 AV	54.0	-18.5	1.28 H	112	29.40	6.10

ANTENNA POLARITY & TEST DISTANCE: VERTICAL AT 3 M

NO.	FREQ. (MHz)	EMISSION LEVEL (dBuV/m)	LIMIT (dBuV/m)	MARGIN (dB)	ANTENNA HEIGHT (m)	TABLE ANGLE (Degree)	RAW VALUE (dBuV)	CORRECTION FACTOR (dB/m)
1	*2452.00	101.2 PK			2.27 V	265	68.50	32.70
2	*2452.00	91.7 AV			2.27 V	265	59.00	32.70
3	2483.50	69.9 PK	74.0	-4.1	2.24 V	267	37.20	32.70
4	2483.50	52.2 AV	54.0	-1.8	2.24 V	267	19.50	32.70
5	4904.00	47.8 PK	74.0	-26.2	1.89 V	241	41.70	6.10
6	4904.00	35.6 AV	54.0	-18.4	1.89 V	241	29.50	6.10

Remarks:

1. Emission Level(dBuV/m) = Raw Value(dBuV) + Correction Factor(dB/m)
2. Correction Factor(dB/m) = Antenna Factor(dB/m) + Cable Factor(dB)
3. The other emission levels were very low against the limit.
4. Margin value = Emission Level – Limit value
5. " * ": Fundamental frequency.

Below 1GHz worst-case data: 802.11b

CHANNEL	TX Channel 1	DETECTOR FUNCTION	Quasi-Peak (QP)
FREQUENCY RANGE	30MHz ~ 1GHz		
TEST MODE	A		

ANTENNA POLARITY & TEST DISTANCE: HORIZONTAL AT 3 M

NO.	FREQ. (MHz)	EMISSION LEVEL (dBuV/m)	LIMIT (dBuV/m)	MARGIN (dB)	ANTENNA HEIGHT (m)	TABLE ANGLE (Degree)	RAW VALUE (dBuV)	CORRECTION FACTOR (dB/m)
1	57.12	31.7 QP	40.0	-8.3	2.00 H	6	46.30	-14.60
2	125.17	30.9 QP	43.5	-12.6	2.00 H	230	46.80	-15.90
3	300.16	40.0 QP	46.0	-6.0	1.00 H	124	52.20	-12.20
4	599.58	43.4 QP	46.0	-2.6	1.49 H	192	49.20	-5.80
5	747.34	45.0 QP	46.0	-1.0	1.49 H	16	47.80	-2.80
6	899.00	44.3 QP	46.0	-1.7	1.00 H	48	44.80	-0.50

ANTENNA POLARITY & TEST DISTANCE: VERTICAL AT 3 M

NO.	FREQ. (MHz)	EMISSION LEVEL (dBuV/m)	LIMIT (dBuV/m)	MARGIN (dB)	ANTENNA HEIGHT (m)	TABLE ANGLE (Degree)	RAW VALUE (dBuV)	CORRECTION FACTOR (dB/m)
1	57.12	30.7 QP	40.0	-9.3	1.00 V	181	45.30	-14.60
2	125.17	32.7 QP	43.5	-10.8	1.00 V	323	48.60	-15.90
3	300.16	35.2 QP	46.0	-10.8	1.00 V	148	47.40	-12.20
4	599.58	41.8 QP	46.0	-4.2	1.00 V	36	47.60	-5.80
5	747.34	38.3 QP	46.0	-7.7	1.50 V	200	41.10	-2.80
6	899.99	43.6 QP	46.0	-2.4	1.00 V	160	44.00	-0.40

Remarks:

1. Emission Level(dBuV/m) = Raw Value(dBuV) + Correction Factor(dB/m)
2. Correction Factor(dB/m) = Antenna Factor(dB/m) + Cable Factor(dB)
3. The other emission levels were very low against the limit.
4. Margin value = Emission Level – Limit value

CHANNEL	TX Channel 1	DETECTOR FUNCTION	Quasi-Peak (QP)
FREQUENCY RANGE	30MHz ~ 1GHz		
TEST MODE	B		

ANTENNA POLARITY & TEST DISTANCE: HORIZONTAL AT 3 M

NO.	FREQ. (MHz)	EMISSION LEVEL (dBuV/m)	LIMIT (dBuV/m)	MARGIN (dB)	ANTENNA HEIGHT (m)	TABLE ANGLE (Degree)	RAW VALUE (dBuV)	CORRECTION FACTOR (dB/m)
1	57.12	31.6 QP	40.0	-8.4	1.99 H	13	46.20	-14.60
2	142.67	31.4 QP	43.5	-12.1	1.99 H	241	45.50	-14.10
3	300.16	37.2 QP	46.0	-8.8	1.00 H	113	49.40	-12.20
4	412.92	36.2 QP	46.0	-9.8	1.99 H	213	46.20	-10.00
5	599.58	43.7 QP	46.0	-2.3	1.50 H	198	49.50	-5.80
6	712.35	36.7 QP	46.0	-9.3	1.00 H	82	40.40	-3.70
7	900.94	43.9 QP	46.0	-2.1	1.50 H	244	44.20	-0.30

ANTENNA POLARITY & TEST DISTANCE: VERTICAL AT 3 M

NO.	FREQ. (MHz)	EMISSION LEVEL (dBuV/m)	LIMIT (dBuV/m)	MARGIN (dB)	ANTENNA HEIGHT (m)	TABLE ANGLE (Degree)	RAW VALUE (dBuV)	CORRECTION FACTOR (dB/m)
1	35.73	37.6 QP	40.0	-2.4	1.00 V	196	53.30	-15.70
2	300.16	37.9 QP	46.0	-8.1	1.50 V	212	50.10	-12.20
3	364.32	31.1 QP	46.0	-14.9	1.50 V	291	42.10	-11.00
4	599.58	42.2 QP	46.0	-3.8	1.00 V	43	48.00	-5.80
5	747.34	40.8 QP	46.0	-5.2	1.50 V	172	43.60	-2.80
6	897.05	44.8 QP	46.0	-1.2	1.50 V	295	45.40	-0.60

Remarks:

1. Emission Level(dBuV/m) = Raw Value(dBuV) + Correction Factor(dB/m)
2. Correction Factor(dB/m) = Antenna Factor(dB/m) + Cable Factor(dB)
3. The other emission levels were very low against the limit.
4. Margin value = Emission Level – Limit value

4.2 Conducted Emission Measurement

4.2.1 Limits of Conducted Emission Measurement

Frequency (MHz)	Conducted Limit (dBuV)	
	Quasi-peak	Average
0.15 - 0.5	66 - 56	56 - 46
0.50 - 5.0	56	46
5.0 - 30.0	60	50

- Note:** 1. The lower limit shall apply at the transition frequencies.
 2. The limit decreases in line with the logarithm of the frequency in the range of 0.15 to 0.50MHz.

4.2.2 Test Instruments

Description & Manufacturer	Model No.	Serial No.	Cal. Date	Cal. Due
Test Receiver ROHDE & SCHWARZ	ESCI	100613	Nov. 16, 2015	Nov. 15, 2016
RF signal cable (with 10dB PAD) Woken	5D-FB	Cable-cond1-01	Dec. 26, 2015	Dec. 25, 2016
LISN ROHDE & SCHWARZ (EUT)	ESH3-Z5	835239/001	Feb. 26, 2015	Feb. 25, 2016
LISN ROHDE & SCHWARZ (Peripheral)	ESH3-Z5	100311	Jul. 24, 2015	Jul. 23, 2016
Software ADT	BV ADT_Cond_ V7.3.7.3	NA	NA	NA

- Note:** 1. The calibration interval of the above test instruments is 12 months and the calibrations are traceable to NML/ROC and NIST/USA.
 2. The test was performed in HwaYa Shielded Room 1.
 3. The VCCI Site Registration No. is C-2040.

4.2.3 Test Procedures

- a. The EUT was placed 0.4 meters from the conducting wall of the shielded room with EUT being connected to the power mains through a line impedance stabilization network (LISN). Other support units were connected to the power mains through another LISN. The two LISNs provide 50 ohm/ 50uH of coupling impedance for the measuring instrument.
- b. Both lines of the power mains connected to the EUT were checked for maximum conducted interference.
- c. The frequency range from 150kHz to 30MHz was searched. Emission levels under (Limit - 20dB) was not recorded.

Note: The resolution bandwidth and video bandwidth of test receiver is 9kHz for quasi-peak detection (QP) and average detection (AV) at frequency 0.15MHz-30MHz.

4.2.4 Deviation from Test Standard

No deviation.

4.2.5 Test Setup

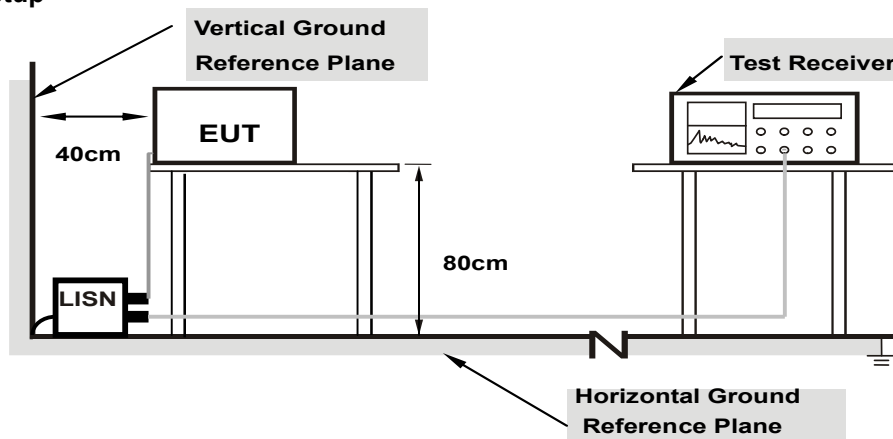

Note: 1.Support units were connected to second LISN.

For the actual test configuration, please refer to the attached file (Test Setup Photo).

4.2.6 EUT Operating Conditions

Same as 4.1.6.

4.2.7 Test Results

Worst-Case Data: 802.11b

Phase	Line (L)	Detector Function	Quasi-Peak (QP) / Average (AV)
Test Mode	A		

No	Freq. [MHz]	Corr. Factor (dB)	Reading Value		Emission Level		Limit		Margin	
			[dB (uV)]		[dB (uV)]		[dB (uV)]		(dB)	
			Q.P.	AV.	Q.P.	AV.	Q.P.	AV.	Q.P.	AV.
1	0.17022	9.94	28.04	12.16	37.98	22.10	64.95	54.95	-26.97	-32.85
2	0.19013	9.95	26.68	15.27	36.63	25.22	64.03	54.03	-27.41	-28.82
3	0.26200	9.97	20.45	10.99	30.42	20.96	61.37	51.37	-30.94	-30.40
4	1.01000	10.11	14.40	6.30	24.51	16.41	56.00	46.00	-31.49	-29.59
5	11.57000	10.66	14.52	5.92	25.18	16.58	60.00	50.00	-34.82	-33.42
6	18.30600	10.96	15.34	9.18	26.30	20.14	60.00	50.00	-33.70	-29.86

Remarks:

1. Q.P. and AV. are abbreviations of quasi-peak and average individually.
2. The emission levels of other frequencies were very low against the limit.
3. Margin value = Emission level - Limit value
4. Correction factor = Insertion loss + Cable loss
5. Emission Level = Correction Factor + Reading Value.

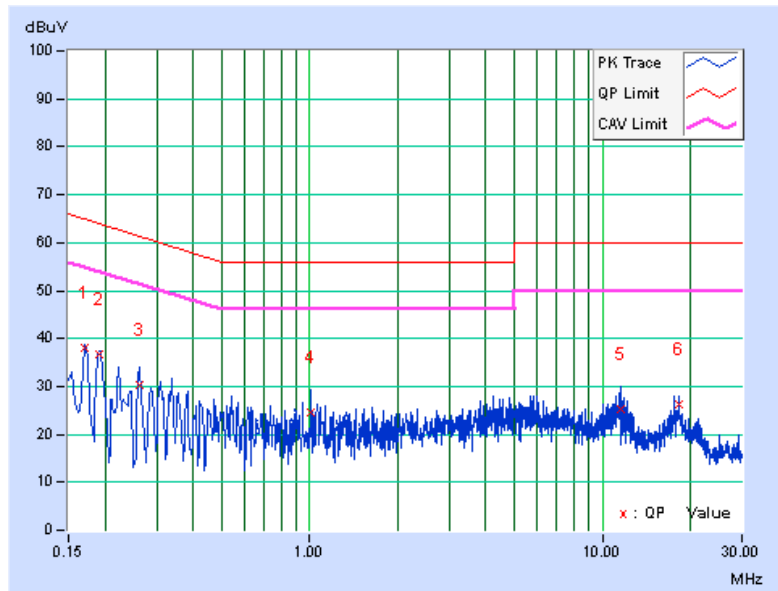

Phase	Neutral (N)	Detector Function	Quasi-Peak (QP) / Average (AV)
Test Mode	A		

No	Freq. [MHz]	Corr. Factor (dB)	Reading Value [dB (uV)]		Emission Level [dB (uV)]		Limit [dB (uV)]		Margin (dB)	
			Q.P.	AV.	Q.P.	AV.	Q.P.	AV.	Q.P.	AV.
			1	0.17000	9.93	26.82	9.29	36.75	19.22	64.96
2	0.19400	9.94	22.82	11.61	32.76	21.55	63.86	53.86	-31.11	-32.32
3	0.23400	9.96	18.97	9.52	28.93	19.48	62.31	52.31	-33.38	-32.83
4	0.61800	10.06	14.08	1.96	24.14	12.02	56.00	46.00	-31.86	-33.98
5	10.76600	10.59	12.90	0.32	23.49	10.91	60.00	50.00	-36.51	-39.09
6	17.69400	10.79	15.08	10.17	25.87	20.96	60.00	50.00	-34.13	-29.04

Remarks:

1. Q.P. and AV. are abbreviations of quasi-peak and average individually.
2. The emission levels of other frequencies were very low against the limit.
3. Margin value = Emission level - Limit value
4. Correction factor = Insertion loss + Cable loss
5. Emission Level = Correction Factor + Reading Value.

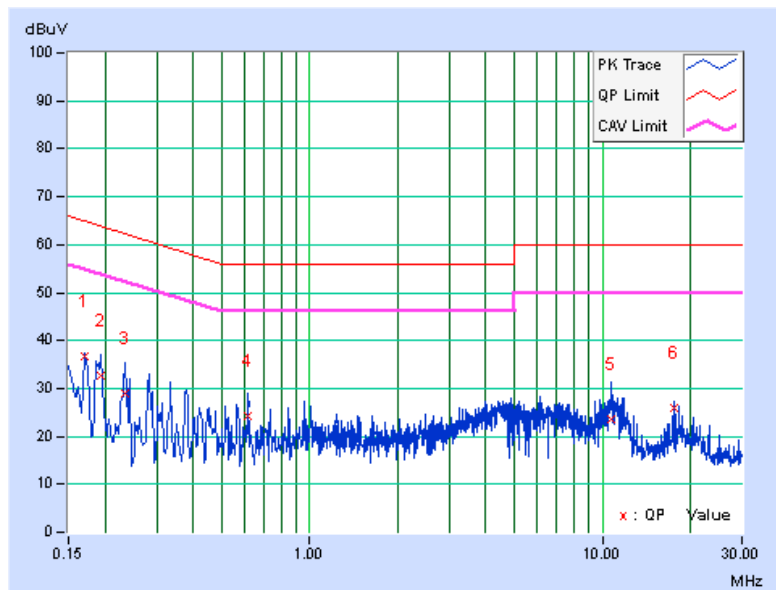

Phase	Line (L)	Detector Function	Quasi-Peak (QP) / Average (AV)
Test Mode	B		

No	Freq. [MHz]	Corr. Factor (dB)	Reading Value [dB (uV)]		Emission Level [dB (uV)]		Limit [dB (uV)]		Margin (dB)	
			Q.P.	AV.	Q.P.	AV.	Q.P.	AV.	Q.P.	AV.
			1	0.15391	9.95	45.11	29.35	55.06	39.30	65.79
2	0.16967	9.99	43.61	26.22	53.60	36.21	64.98	54.98	-11.38	-18.77
3	0.19692	10.05	38.64	22.44	48.69	32.49	63.74	53.74	-15.05	-21.25
4	0.32272	10.06	31.89	24.21	41.95	34.27	59.64	49.64	-17.69	-15.37
5	3.05513	10.29	19.87	12.31	30.16	22.60	56.00	46.00	-25.84	-23.40
6	7.81751	10.54	23.16	17.23	33.70	27.77	60.00	50.00	-26.30	-22.23

Remarks:

1. Q.P. and AV. are abbreviations of quasi-peak and average individually.
2. The emission levels of other frequencies were very low against the limit.
3. Margin value = Emission level - Limit value
4. Correction factor = Insertion loss + Cable loss
5. Emission Level = Correction Factor + Reading Value.

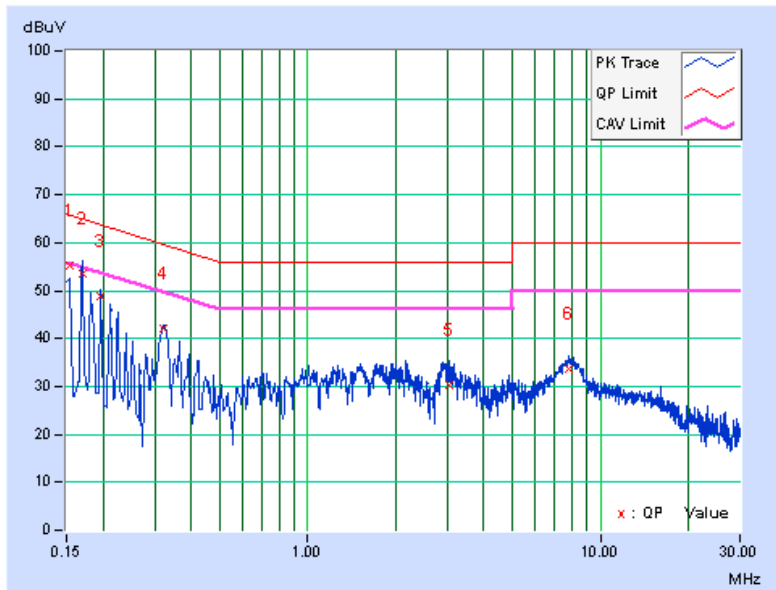

Phase	Neutral (N)	Detector Function	Quasi-Peak (QP) / Average (AV)
Test Mode	B		

No	Freq. [MHz]	Corr. Factor (dB)	Reading Value [dB (uV)]		Emission Level [dB (uV)]		Limit [dB (uV)]		Margin (dB)	
			Q.P.	AV.	Q.P.	AV.	Q.P.	AV.	Q.P.	AV.
			1	0.15391	9.97	44.45	29.18	54.42	39.15	65.79
2	0.16955	9.98	42.71	27.67	52.69	37.65	64.98	54.98	-12.29	-17.33
3	0.19692	10.00	38.00	24.05	48.00	34.05	63.74	53.74	-15.74	-19.69
4	0.32102	10.07	36.26	30.14	46.33	40.21	59.68	49.68	-13.35	-9.47
5	2.78534	10.32	24.19	19.48	34.51	29.80	56.00	46.00	-21.49	-16.20
6	7.83315	10.56	22.73	17.58	33.29	28.14	60.00	50.00	-26.71	-21.86

Remarks:

1. Q.P. and AV. are abbreviations of quasi-peak and average individually.
2. The emission levels of other frequencies were very low against the limit.
3. Margin value = Emission level - Limit value
4. Correction factor = Insertion loss + Cable loss
5. Emission Level = Correction Factor + Reading Value.

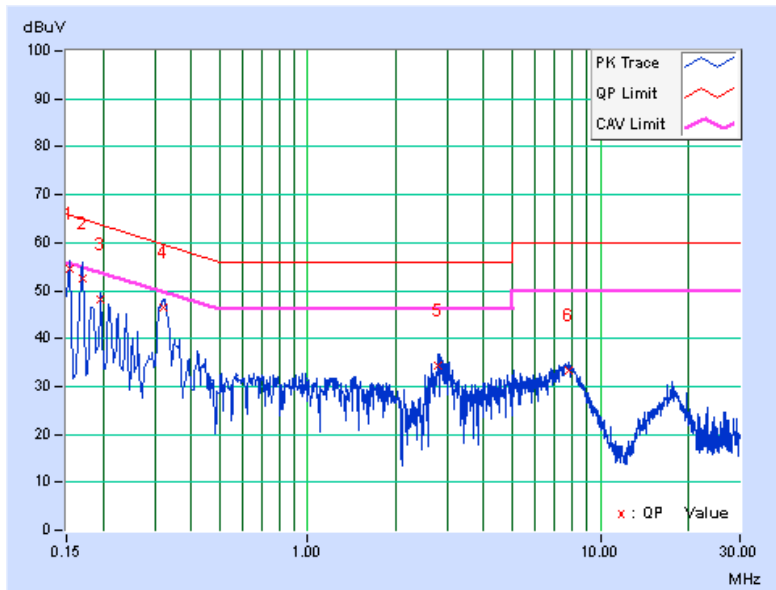

4.3 6dB Bandwidth Measurement

4.3.1 Limits of 6dB Bandwidth Measurement

The minimum of 6dB Bandwidth Measurement is 0.5 MHz.

4.3.2 Test Setup

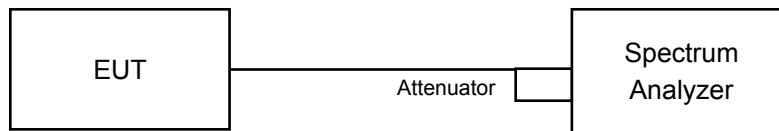

4.3.3 Test Instruments

Refer to section 4.1.2 to get information of above instrument.

4.3.4 Test Procedure

- Set resolution bandwidth (RBW) = 100kHz
- Set the video bandwidth (VBW) $\geq 3 \times$ RBW, Detector = average.
- Trace mode = max hold.
- Sweep = auto couple.
- Measure the maximum width of the emission that is constrained by the frequencies associated with the two amplitude points (upper and lower) that are attenuated by 6 dB relative to the maximum level measured in the fundamental emission

4.3.5 Deviation from Test Standard

No deviation.

4.3.6 EUT Operating Conditions

The software provided by client to enable the EUT under transmission condition continuously at lowest, middle and highest channel frequencies individually.

4.3.7 Test Result

802.11b

Channel	Frequency (MHz)	6dB Bandwidth (MHz)	Minimum Limit (MHz)	Pass / Fail
1	2412	7.10	0.5	Pass
6	2437	7.09	0.5	Pass
11	2462	7.11	0.5	Pass

802.11g

Channel	Frequency (MHz)	6dB Bandwidth (MHz)	Minimum Limit (MHz)	Pass / Fail
1	2412	16.38	0.5	Pass
6	2437	16.41	0.5	Pass
11	2462	16.41	0.5	Pass

802.11n (20MHz)

Channel	Frequency (MHz)	6dB Bandwidth (MHz)		Minimum Limit (MHz)	Pass / Fail
		Chain 0	Chain 1		
1	2412	17.63	17.59	0.5	Pass
6	2437	17.62	17.60	0.5	Pass
11	2462	17.62	17.63	0.5	Pass

802.11n (40MHz)

Channel	Frequency (MHz)	6dB Bandwidth (MHz)		Minimum Limit (MHz)	Pass / Fail
		Chain 0	Chain 1		
3	2422	36.45	36.44	0.5	Pass
6	2437	36.15	36.36	0.5	Pass
9	2452	36.38	36.12	0.5	Pass

Spectrum Plot of Worst Value

802.11b

802.11g

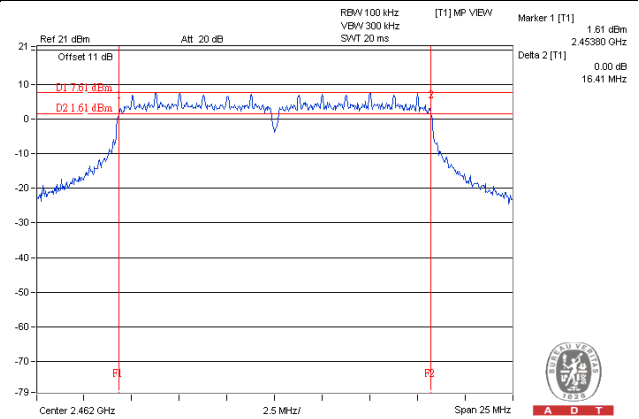
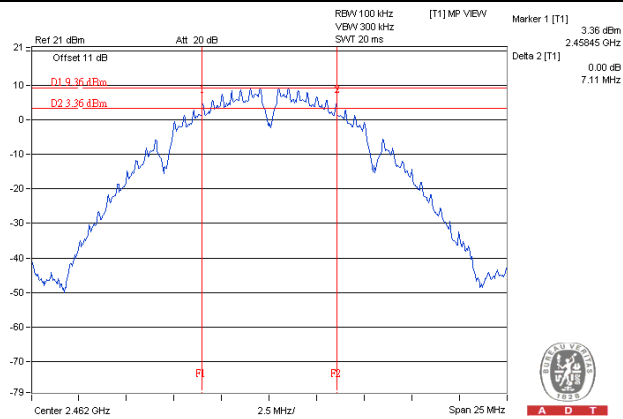

802.11n (20MHz)

802.11n (40MHz)

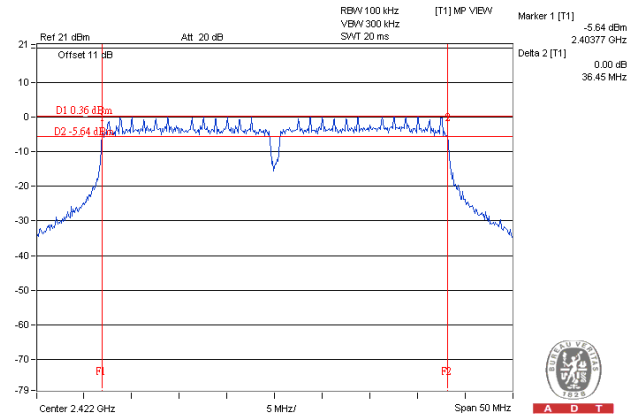
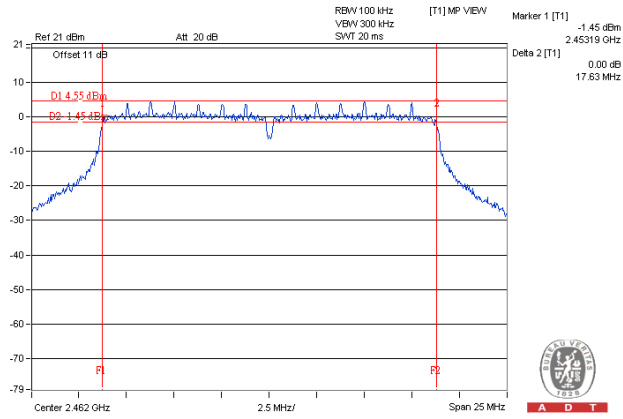

4.4 Conducted Output Power Measurement

4.4.1 Limits of Conducted Output Power Measurement

For systems using digital modulation in the 2400–2483.5 MHz bands: 1 Watt (30dBm)

Per KDB 662911 D01 Multiple Transmitter Output Method of conducted output power measurement on IEEE 802.11 devices,

- Array Gain = 0 dB (i.e., no array gain) for NANT ≤ 4;
- Array Gain = 0 dB (i.e., no array gain) for channel widths ≥ 40 MHz for any NANT;
- Array Gain = 5 log(NANT/NSS) dB or 3 dB, whichever is less for 20-MHz channel widths with NANT ≥ 5.

For power measurements on all other devices: Array Gain = 10 log(NANT/NSS) dB.

4.4.2 Test Setup

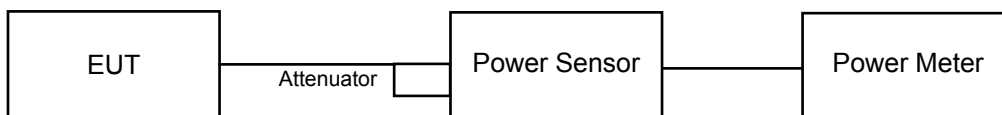

4.4.3 Test Instruments

Refer to section 4.1.2 to get information of above instrument.

4.4.4 Test Procedures

An average power sensor was used on the output port of the EUT. A power meter was used to read the response of the average power sensor. Record the power level.

4.4.5 Deviation from Test Standard

No deviation.

4.4.6 EUT Operating Conditions

Same as Item 4.3.6.

4.4.7 Test Results

802.11b

Channel	Frequency (MHz)	Average Power (mW)	Average Power (dBm)	Limit (dBm)	Pass / Fail
1	2412	76.913	18.86	30	Pass
6	2437	63.680	18.04	30	Pass
11	2462	47.973	16.81	30	Pass

802.11g

Channel	Frequency (MHz)	Average Power (mW)	Average Power (dBm)	Limit (dBm)	Pass / Fail
1	2412	56.885	17.55	30	Pass
6	2437	251.768	24.01	30	Pass
11	2462	80.168	19.04	30	Pass

802.11n (20MHz)

Channel	Frequency (MHz)	Average Power (dBm)		Total Power (mW)	Total Power (dBm)	Limit (dBm)	Pass / Fail
		Chain 0	Chain 1				
1	2412	16.51	15.14	77.430	18.89	30	Pass
6	2437	23.38	22.20	383.730	25.84	30	Pass
11	2462	16.19	15.42	76.425	18.83	30	Pass

802.11n (40MHz)

Channel	Frequency (MHz)	Average Power (dBm)		Total Power (mW)	Total Power (dBm)	Limit (dBm)	Pass / Fail
		Chain 0	Chain 1				
3	2422	14.21	13.05	46.547	16.68	30	Pass
6	2437	17.68	16.54	103.696	20.16	30	Pass
9	2452	15.46	14.25	61.763	17.91	30	Pass

4.5 Power Spectral Density Measurement

4.5.1 Limits of Power Spectral Density Measurement

The Maximum of Power Spectral Density Measurement is 8dBm.

4.5.2 Test Setup

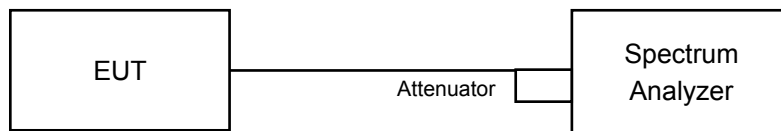

4.5.3 Test Instruments

Refer to section 4.1.2 to get information of above instrument.

4.5.4 Test Procedure

For duty cycle $\geq 98\%$

- a. Set instrument center frequency to DTS channel center frequency.
- b. Set span to at least 1.5 times the OBW.
- c. Set RBW to: $3 \text{ kHz} \leq \text{RBW} \leq 100 \text{ kHz}$.
- d. Set VBW $\geq 3 \times \text{RBW}$.
- e. Detector = power averaging (RMS) or sample detector (when RMS not available).
- f. Ensure that the number of measurement points in the sweep $\geq 2 \times \text{span}/\text{RBW}$.
- g. Sweep time = auto couple.
- h. Employ trace averaging (RMS) mode over a minimum of 100 traces.
- i. Use the peak marker function to determine the maximum amplitude level.

For duty cycle $< 98\%$

- a. Measure the duty cycle (x).
- b. Set instrument center frequency to DTS channel center frequency.
- c. Set span to at least 1.5 times the OBW.
- d. Set RBW to: $3 \text{ kHz} \leq \text{RBW} \leq 100 \text{ kHz}$.
- e. Set VBW $\geq 3 \times \text{RBW}$.
- f. Detector = power averaging (RMS) or sample detector (when RMS not available).
- g. Ensure that the number of measurement points in the sweep $\geq 2 \times \text{span}/\text{RBW}$.
- h. Sweep time = auto couple.
- i. Do not use sweep triggering. Allow sweep to "free run".
- j. Employ trace averaging (RMS) mode over a minimum of 100 traces.
- k. Use the peak marker function to determine the maximum amplitude level.
- l. Add $10 \log (1/x)$, where x is the duty cycle measured in step (a), to the measured PSD to compute the average PSD during the actual transmission time.

4.5.5 Deviation from Test Standard

No deviation.

4.5.6 EUT Operating Condition

Same as Item 4.3.6

4.5.7 Test Results

802.11b

Channel	Frequency (MHz)	PSD (dBm)	Limit (dBm)	Pass / Fail
1	2412	-7.84	8.00	Pass
6	2437	-8.56	8.00	Pass
11	2462	-10.03	8.00	Pass

802.11g

Channel	Frequency (MHz)	PSD (dBm)	Duty Factor	Total PSD with Duty Factor (dBm)	Limit (dBm)	Pass / Fail
1	2412	-9.84	0.13	-9.71	8.00	Pass
6	2437	1.73	0.13	1.86	8.00	Pass
11	2462	-11.78	0.13	-11.65	8.00	Pass

Note: Refer to section 3.3 for duty cycle spectrum plot.

802.11n (20MHz)

TX chain	Channel	Frequency (MHz)	PSD (dBm)	10 log (N=2) dB	Duty Factor	Total PSD with Duty Factor (dBm)	Limit (dBm)	Pass / Fail
0	1	2412	-13.38	3.01	0.12	-10.25	7.85	Pass
	6	2437	-1.15	3.01	0.12	1.98	7.85	Pass
	11	2462	-15.47	3.01	0.12	-12.34	7.85	Pass
1	1	2412	-15.32	3.01	0.12	-12.19	7.85	Pass
	6	2437	-8.07	3.01	0.12	-4.94	7.85	Pass
	11	2462	-15.37	3.01	0.12	-12.24	7.85	Pass

Note:

- Method 1 of power density measurement of KDB 662911 is using for calculating total power density. Total power density is summing entire spectra across corresponding frequency bins on the various outputs by computer.
- Directional gain = $10 \log[(10^{G1/20} + 10^{G2/20} + \dots + 10^{GN/20})^2 / N_{ANT}] = 6.15 \text{dBi} > 6 \text{dBi}$, so the power density limit shall be reduced to $8 - (6.15 - 6) = 7.85 \text{dBm}$.
- Refer to section 3.3 for duty cycle spectrum plot.

802.11n (40MHz)

TX chain	Channel	Frequency (MHz)	PSD (dBm)	10 log (N=2) dB	Duty Factor	Total PSD with Duty Factor (dBm)	Limit (dBm)	Pass / Fail
0	3	2422	-19.12	3.01	0.21	-15.90	7.85	Pass
	6	2437	-15.94	3.01	0.21	-12.72	7.85	Pass
	9	2452	-18.09	3.01	0.21	-14.87	7.85	Pass
1	3	2422	-19.74	3.01	0.21	-16.52	7.85	Pass
	6	2437	-16.54	3.01	0.21	-13.32	7.85	Pass
	9	2452	-18.64	3.01	0.21	-15.42	7.85	Pass

Note:

- Method 1 of power density measurement of KDB 662911 is using for calculating total power density. Total power density is summing entire spectra across corresponding frequency bins on the various outputs by computer.
- Directional gain = $10 \log[(10^{G1/20} + 10^{G2/20} + \dots + 10^{GN/20})^2 / N_{ANT}] = 6.15 \text{dBi} > 6 \text{dBi}$, so the power density limit shall be reduced to $8 - (6.15 - 6) = 7.85 \text{dBm}$.
- Refer to section 3.3 for duty cycle spectrum plot.

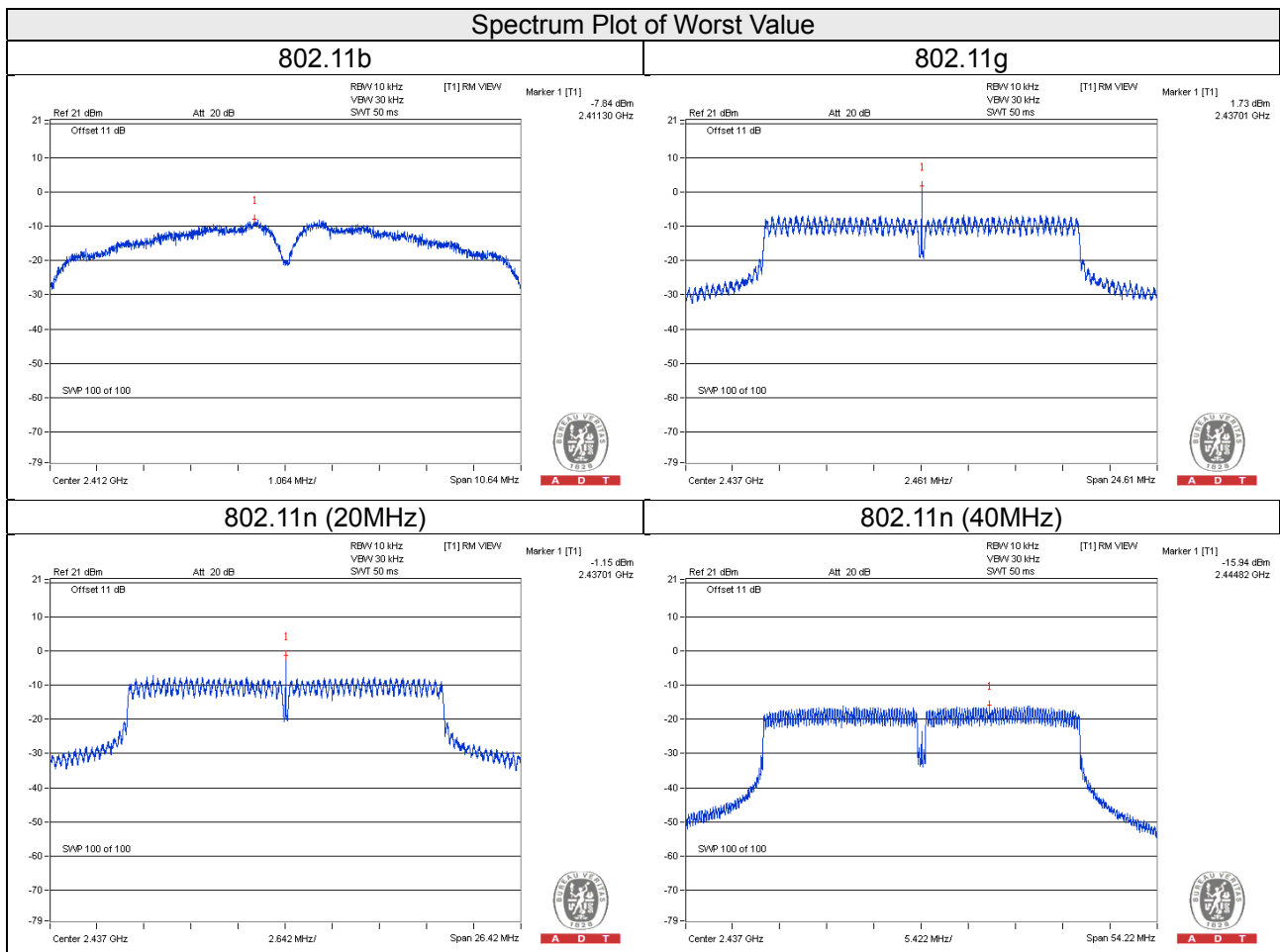

4.6 Conducted Out of Band Emission Measurement

4.6.1 Limits of Conducted Out of Band Emission Measurement

Below 30dB of the highest emission level of operating band (in 100kHz Resolution Bandwidth).

4.6.2 Test Setup

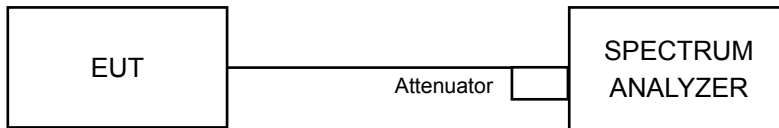

4.6.3 Test Instruments

Refer to section 4.1.2 to get information of above instrument.

4.6.4 Test Procedure

MEASUREMENT PROCEDURE REF

- Set the RBW = 100 kHz.
- Set the VBW \geq 300 kHz.
- Detector = average.
- Sweep time = auto couple.
- Trace mode = max hold.
- Allow trace to fully stabilize.
- Use the peak marker function to determine the maximum power level in any 100 kHz band segment within the fundamental EBW.

MEASUREMENT PROCEDURE OOBE

- Set RBW = 100 kHz.
- Set VBW \geq 300 kHz.
- Ensure that the number of measurement points \geq span/RBW
- According to measurement points to set differ measurement span.
- Detector = average.
- Trace Mode = max hold.
- Sweep = auto couple.

4.6.5 Deviation from Test Standard

No deviation.

4.6.6 EUT Operating Condition

Same as Item 4.3.6

4.6.7 Test Results

The spectrum plots are attached on the following pages. D1 line indicates the highest level, and D2 line indicates the 30dB offset below D1. It shows compliance with the requirement.

802.11b_Chain 0

CH 1

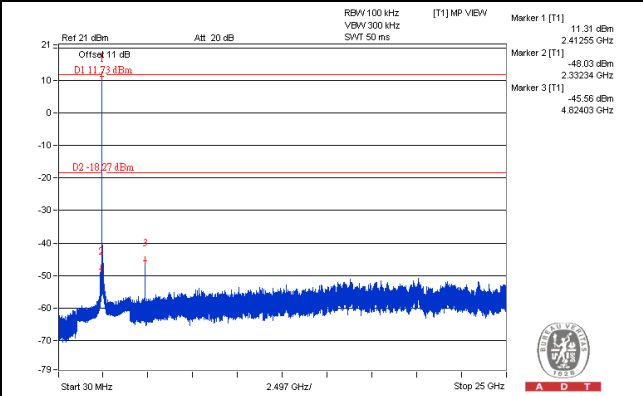
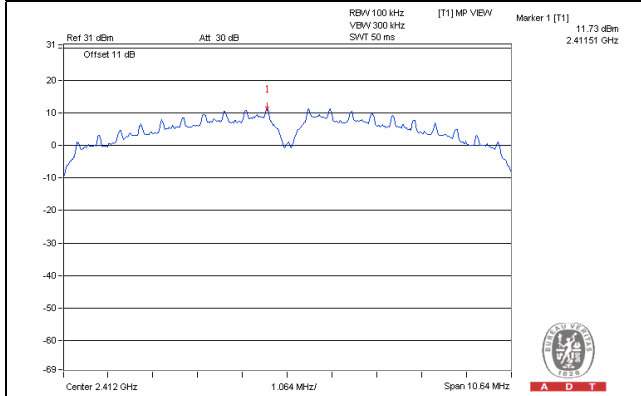

CH 6

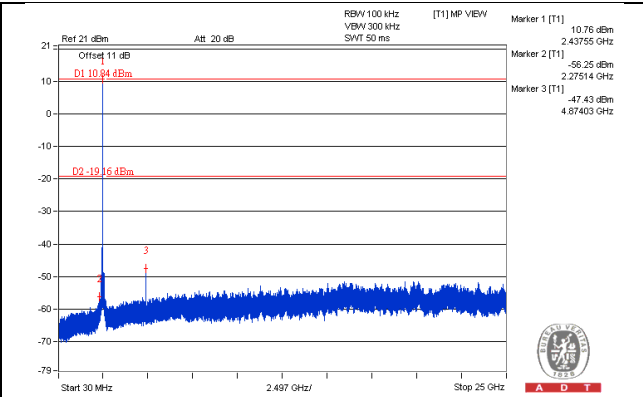
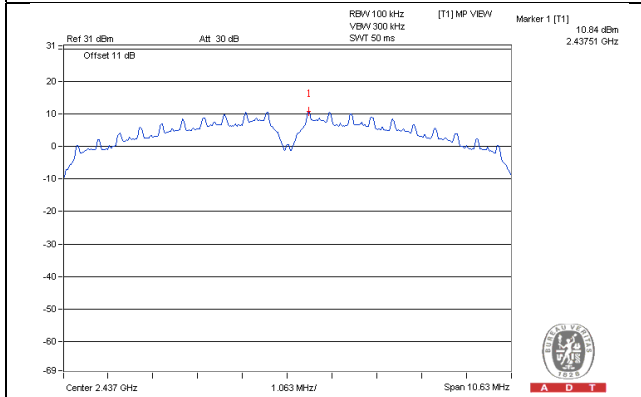

CH 11

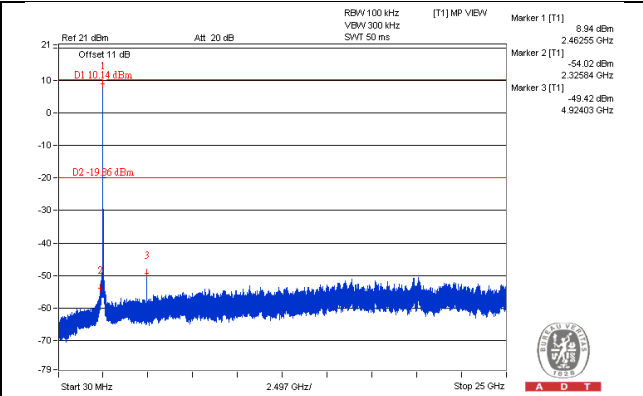
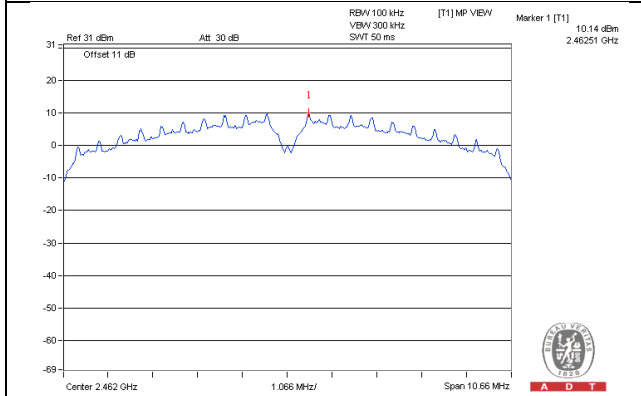

CH 1 Band edge

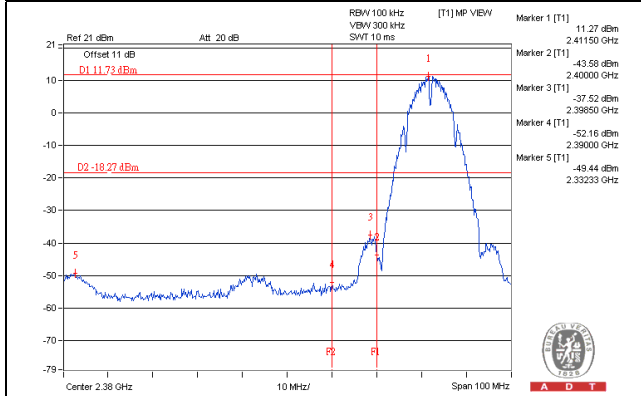

CH 11 Band edge

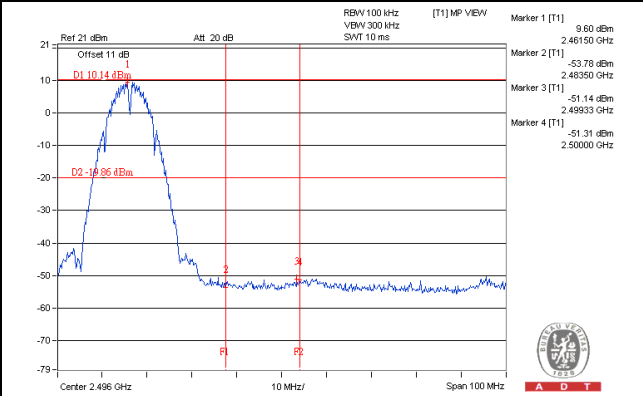

802.11g_Chain 0

CH 1

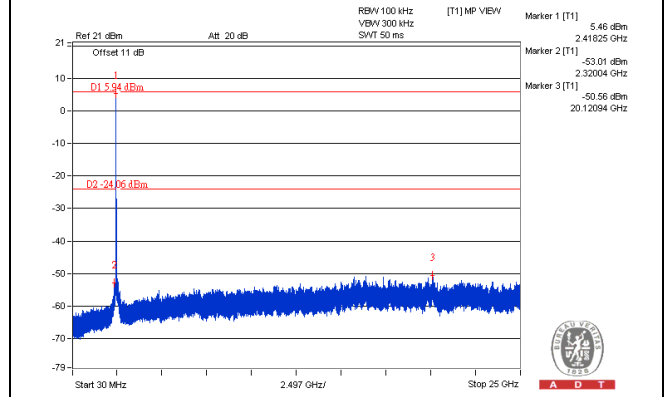
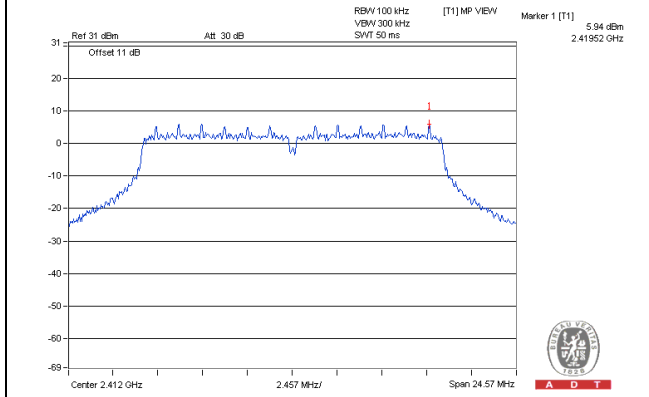

CH 6

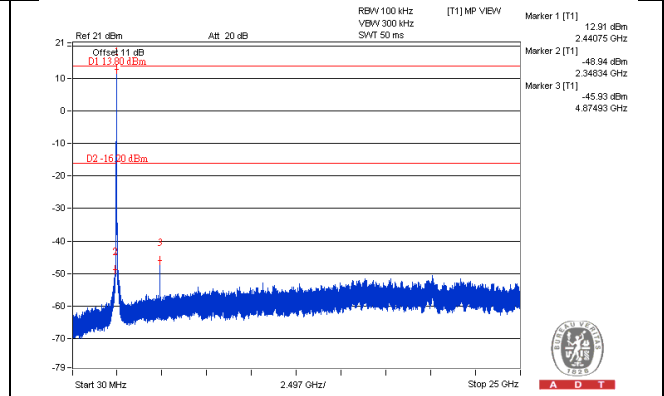
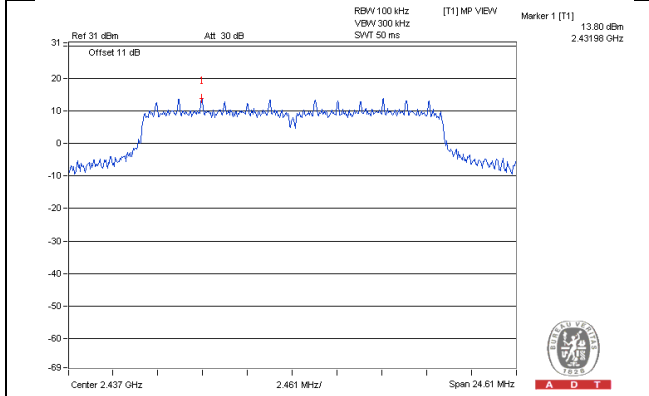

CH 11

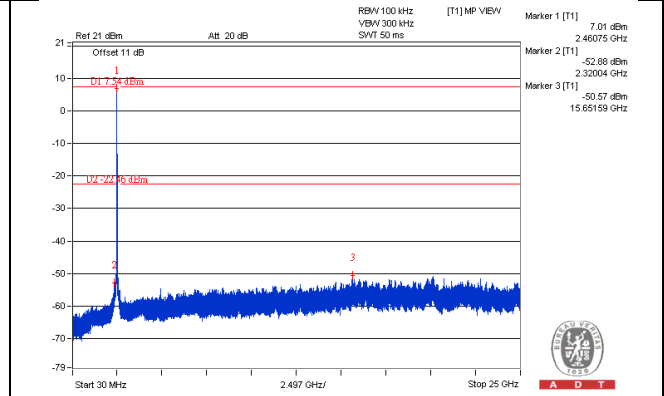
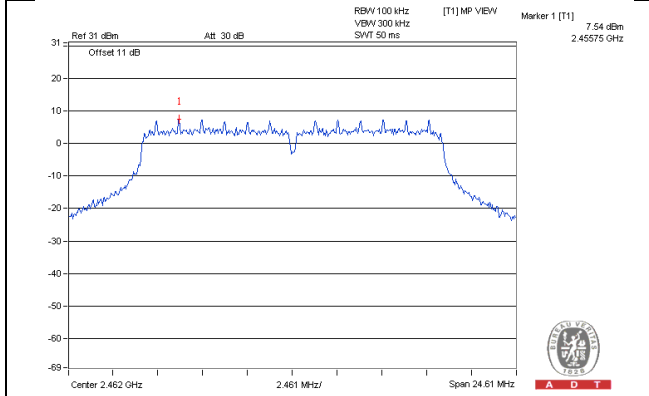

CH 1 Band edge

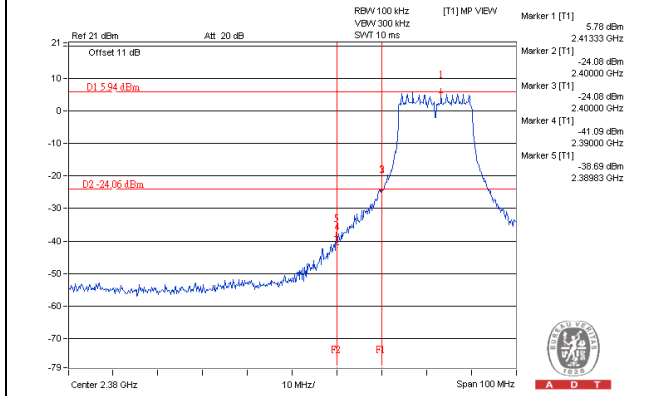

CH 11 Band edge

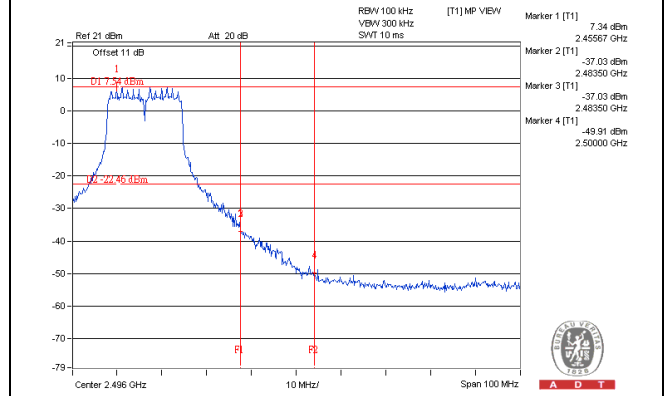

802.11n (20MHz)_Chain 0

CH 1

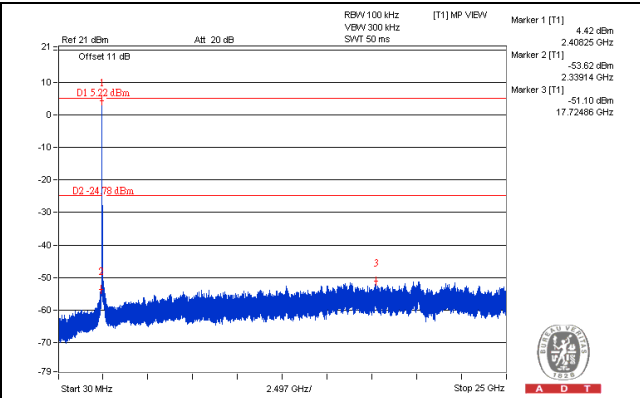
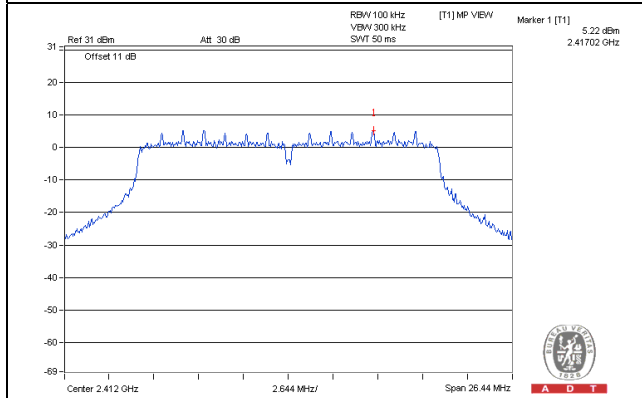

CH 6

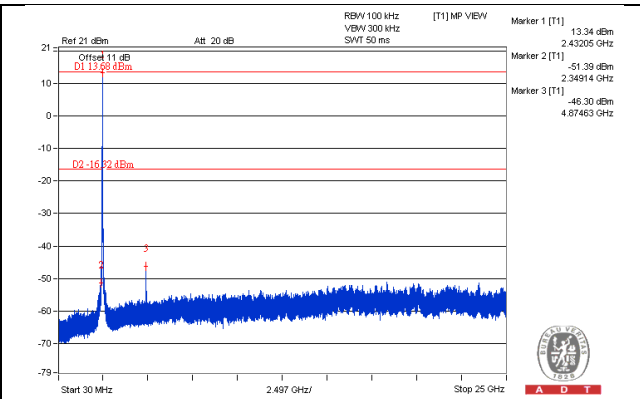
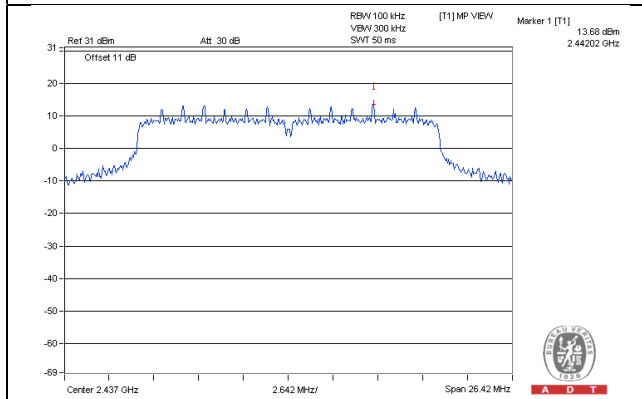

CH 11

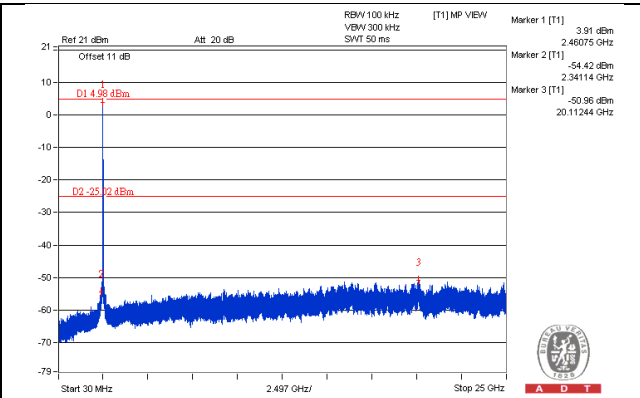
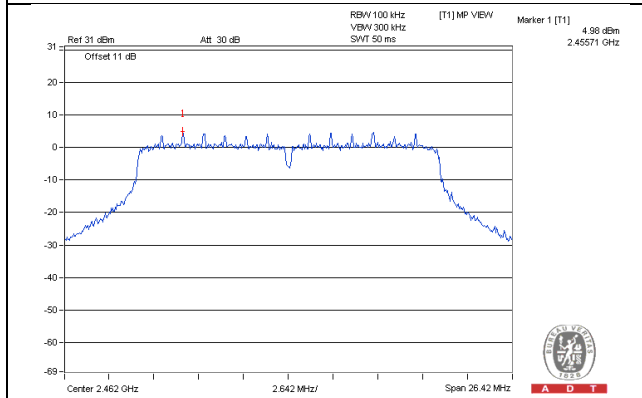

CH 1 Band edge

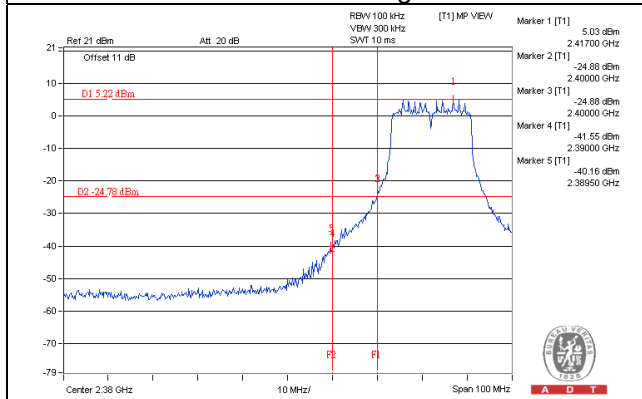

CH 11 Band edge

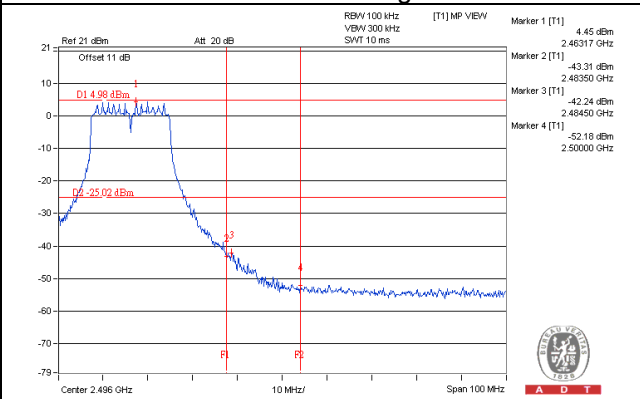

802.11n (20MHz)_Chain 1

CH 1

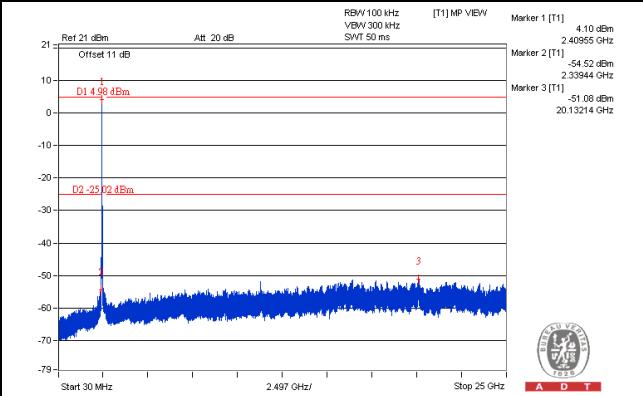
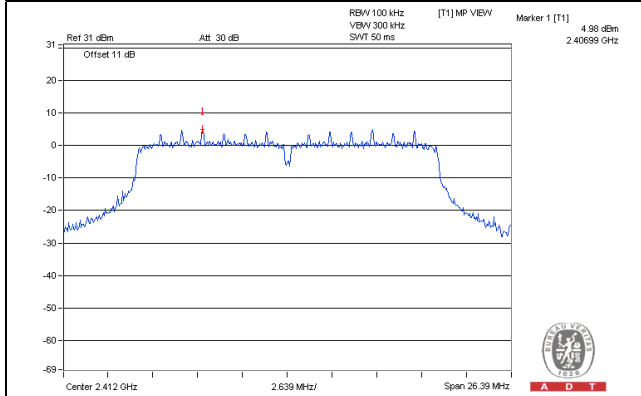

CH 6

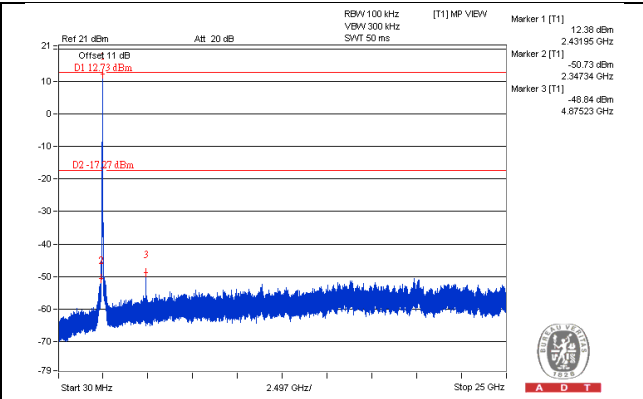
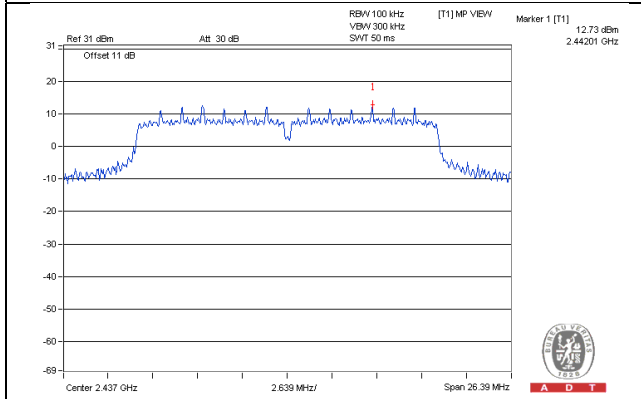

CH 11

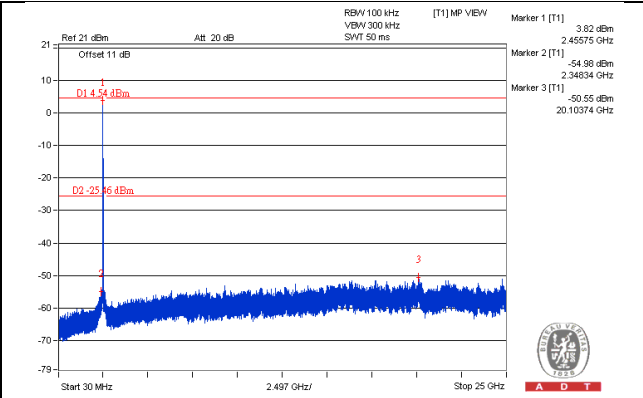
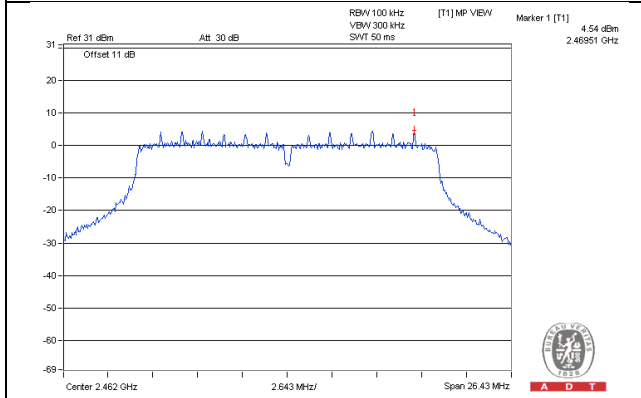

CH 1 Band edge

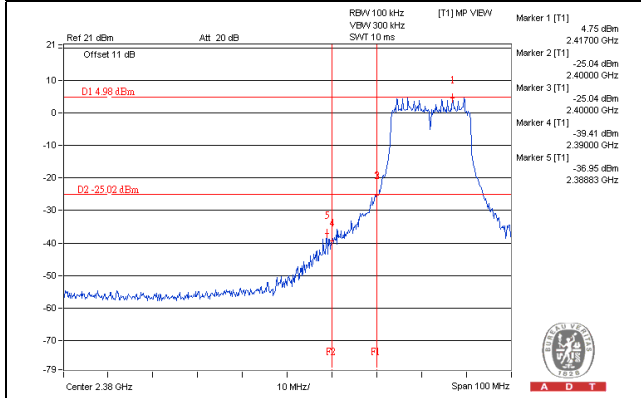

CH 11 Band edge

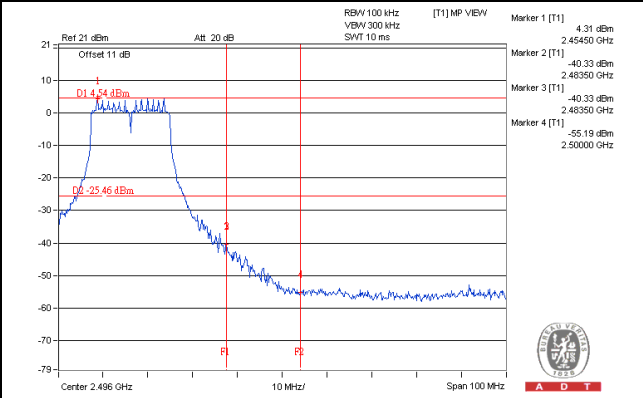

802.11n (40MHz) _Chain 0

CH 3

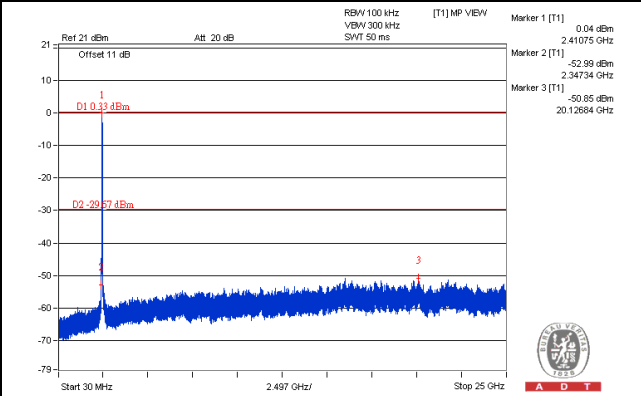
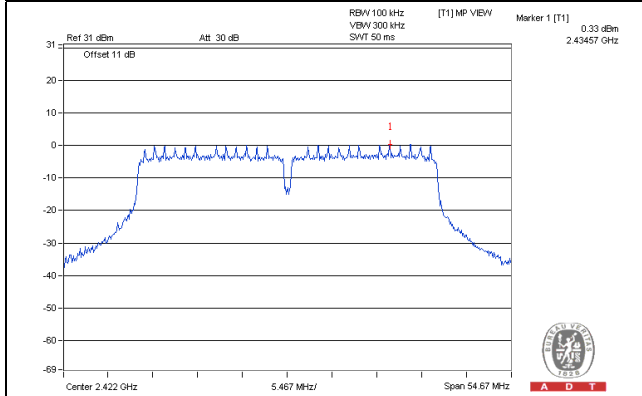

CH 6

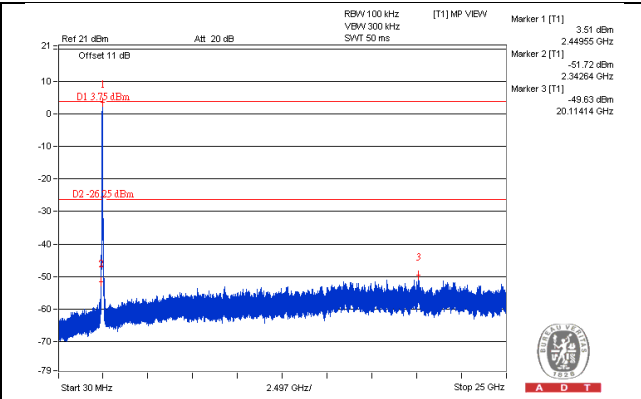
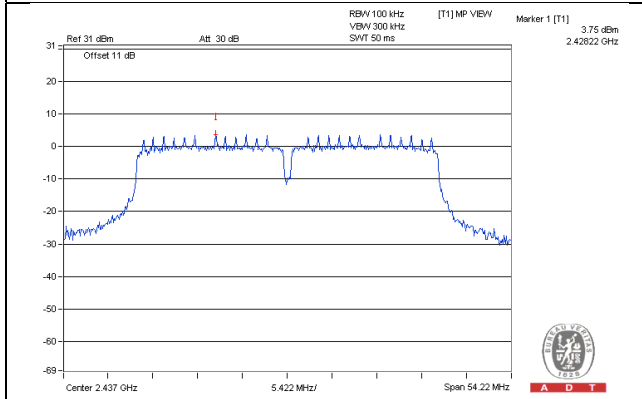

CH 9

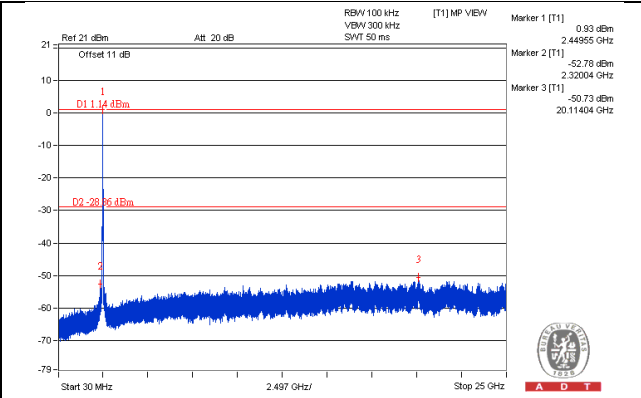
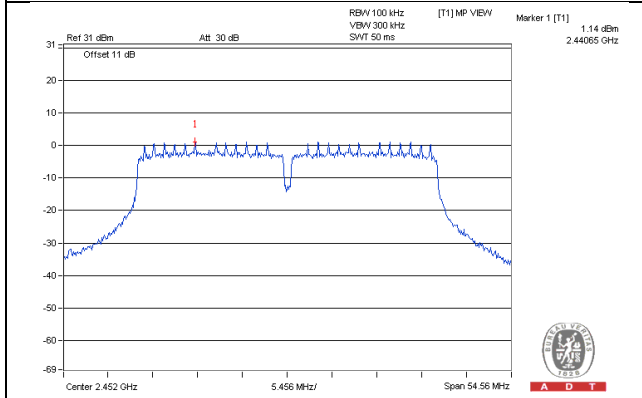

CH 3 Band edge

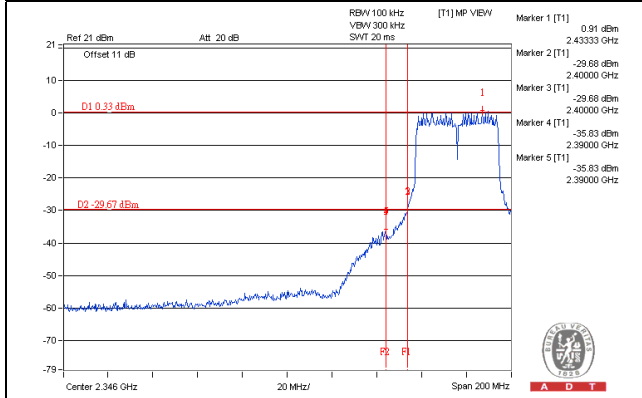

CH 9 Band edge

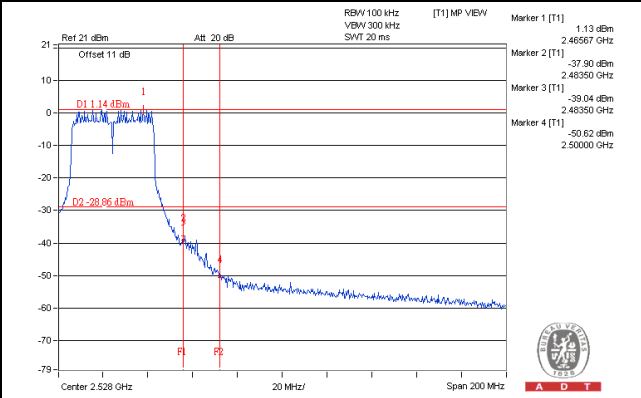

802.11n (40MHz) _Chain 1

CH 3

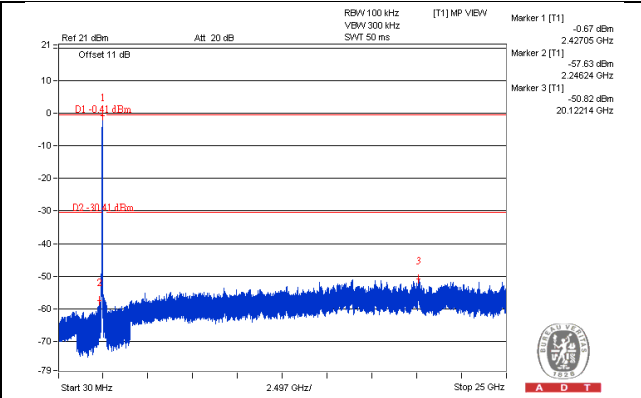
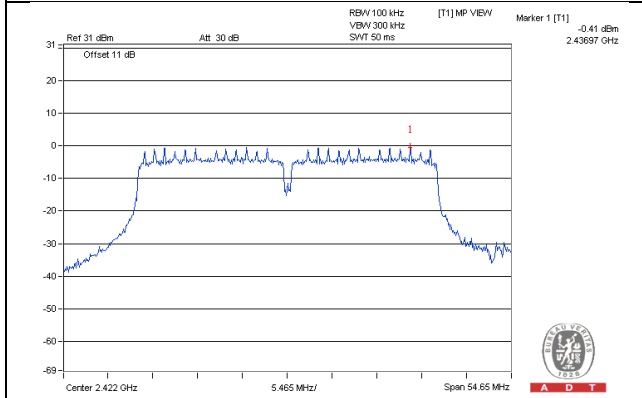

CH 6

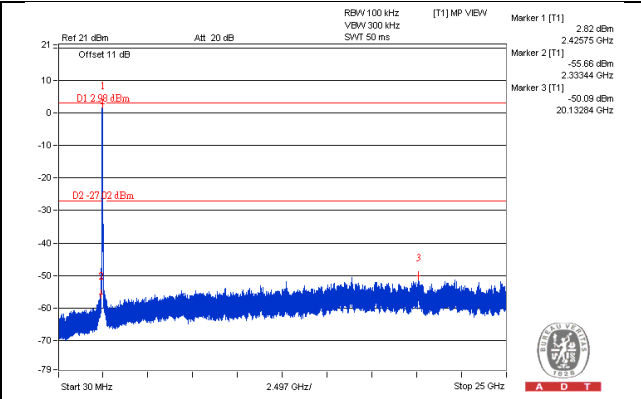
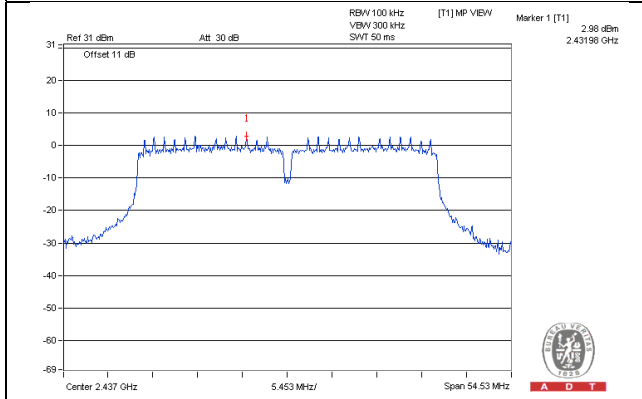

CH 9

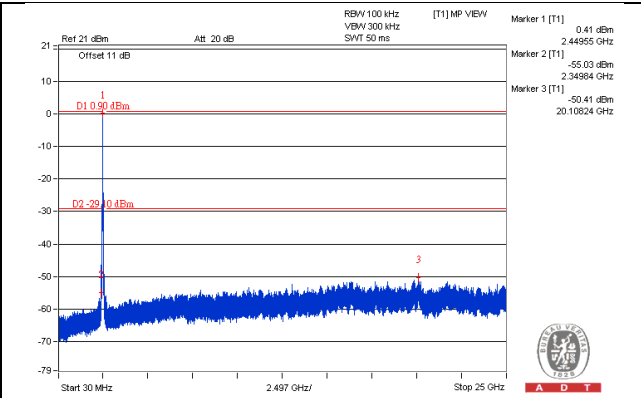
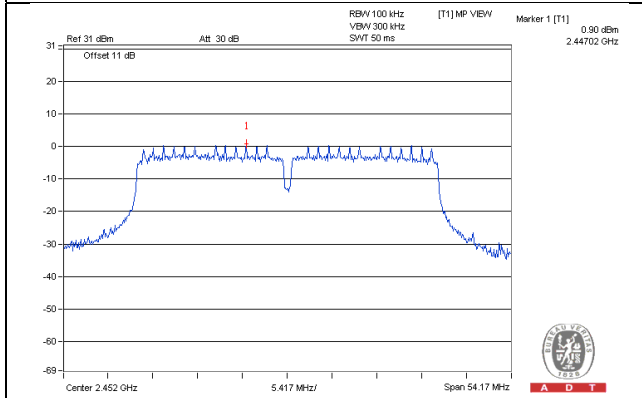

CH 3 Band edge

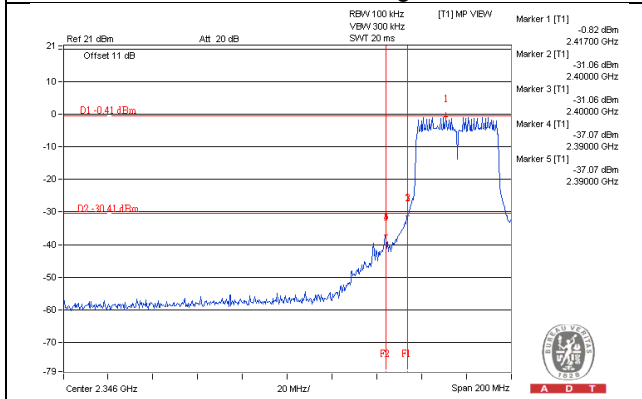

CH 9 Band edge

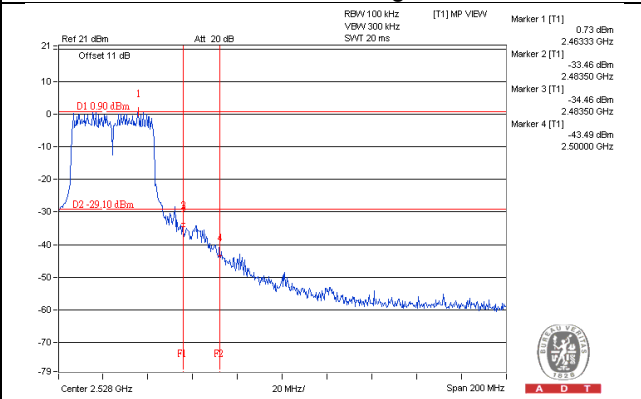



5 Pictures of Test Arrangements

Please refer to the attached file (Test Setup Photo).



Appendix – Information on the Testing Laboratories

We, Bureau Veritas Consumer Products Services (H.K.) Ltd., Taoyuan Branch, were founded in 1988 to provide our best service in EMC, Radio, Telecom and Safety consultation. Our laboratories are accredited and approved according to ISO/IEC 17025.

If you have any comments, please feel free to contact us at the following:

Linko EMC/RF Lab

Tel: 886-2-26052180

Fax: 886-2-26051924

Hsin Chu EMC/RF/Telecom Lab

Tel: 886-3-6668565

Fax: 886-3-6668323

Hwa Ya EMC/RF/Safety Lab

Tel: 886-3-3183232

Fax: 886-3-3270892

Email: service.adt@tw.bureauveritas.com

Web Site: www.bureauveritas-adt.com

The address and road map of all our labs can be found in our web site also.

--- END ---