

FCC Test Report

Report No.: RF150417C34-1

FCC ID: WT8OM5PAC

Test Model: OM5P-AC

Received Date: Apr. 28, 2015

Test Date: May 18 ~ May 19, 2015

Issued Date: May 21, 2015

Applicant: Open Mesh, Inc.

Address: 5 Centerpointe Drive, Suite 400, Lake Oswego, Oregon, USA 97035

Issued By: Bureau Veritas Consumer Products Services (H.K.) Ltd., Taoyuan Branch

Lab Address: No. 47-2, 14th Ling, Chia Pau Vil., Lin Kou Dist., New Taipei City, Taiwan, R.O.C.

Test Location: No. 19, Hwa Ya 2nd Rd., Wen Hwa Vil., Kwei Shan Dist., Taoyuan City 33383, TAIWAN (R.O.C.)



This report is for your exclusive use. Any copying or replication of this report to or for any other person or entity, or use of our name or trademark, is permitted only with our prior written permission. This report sets forth our findings solely with respect to the test samples identified herein. The results set forth in this report are not indicative or representative of the quality or characteristics of the lot from which a test sample was taken or any similar or identical product specifically and expressly noted. Our report includes all of the tests requested by you and the results thereof based upon the information that you provided to us. You have 60 days from date of issuance of this report to notify us of any material error or omission caused by our negligence, provided, however, that such notice shall be in writing and shall specifically address the issue you wish to raise. A failure to raise such issue within the prescribed time shall constitute your unqualified acceptance of the completeness of this report, the tests conducted and the correctness of the report contents. Unless specific mention, the uncertainty of measurement has been explicitly taken into account to declare the compliance or non-compliance to the specification. The report must not be used by the client to claim product certification, approval, or endorsement by TAF or any government agencies.

Table of Contents

Release Control Record	4
1 Certificate of Conformity	5
2 Summary of Test Results	6
2.1 Measurement Uncertainty.....	6
2.2 Modification Record.....	6
3 General Information	7
3.1 General Description of EUT.....	7
3.2 Description of Test Modes.....	9
3.2.1 Test Mode Applicability and Tested Channel Detail.....	10
3.3 Duty Cycle of Test Signal.....	12
3.4 Description of Support Units.....	17
3.4.1 Configuration of System under Test.....	18
3.5 General Description of Applied Standards.....	19
4 Test Types and Results	20
4.1 Radiated Emission and Bandedge Measurement.....	20
4.1.1 Limits of Radiated Emission and Bandedge Measurement.....	20
4.1.2 Test Instruments.....	21
4.1.3 Test Procedures.....	22
4.1.4 Deviation from Test Standard.....	22
4.1.5 Test Set Up.....	23
4.1.6 EUT Operating Conditions.....	23
4.1.7 Test Results.....	24
4.2 Conducted Emission Measurement.....	40
4.2.1 Limits of Conducted Emission Measurement.....	40
4.2.2 Test Instruments.....	40
4.2.3 Test Procedures.....	41
4.2.4 Deviation from Test Standard.....	41
4.2.5 Test Setup.....	41
4.2.6 EUT Operating Conditions.....	41
4.2.7 Test Results.....	42
4.3 Transmit Power Measurement.....	46
4.3.1 Limits of Transmit Power Measurement.....	46
4.3.2 Test Setup.....	46
4.3.3 Test Instruments.....	46
4.3.4 Test Procedure.....	47
4.3.5 Deviation from Test Standard.....	47
4.3.6 EUT Operating Conditions.....	47
4.3.7 Test Result.....	48
4.4 Peak Power Spectral Density Measurement.....	53
4.4.1 Limits of Peak Power Spectral Density Measurement.....	53
4.4.2 Test Setup.....	53
4.4.3 Test Instruments.....	53
4.4.4 Test Procedures.....	53
4.4.5 Deviation from Test Standard.....	53
4.4.6 EUT Operating Conditions.....	53
4.4.7 Test Results.....	54
4.5 Peak Power Excursion Measurement.....	57
4.5.1 Limits of Peak Power Excursion Measurement.....	57
4.5.2 Test Setup.....	57
4.5.3 Test Instruments.....	57
4.5.4 Test Procedure.....	57
4.5.5 Deviation From Test Standard.....	57
4.5.6 EUT Operating Condition.....	57



4.5.7 Test Results	58
4.6 Frequency Stability.....	60
4.6.1 Limits of Frequency Stability Measurement	60
4.6.2 Test Setup.....	60
4.6.3 Test Instruments	60
4.6.4 Test Procedure	60
4.6.5 Deviation from Test Standard	60
4.6.6 EUT Operating Condition	60
4.6.7 Test Results	61
5 Pictures of Test Arrangements.....	62
Appendix – Information on the Testing Laboratories	63



A D T

Release Control Record

Issue No.	Description	Date Issued
RF150417C34-1	Original release	May 21, 2015

1 Certificate of Conformity

Product: Wireless Access Point
Brand: Open Mesh
Test Model: OM5P-AC
Sample Status: Engineering sample
Applicant: Open Mesh, Inc.
Test Date: May 18 ~ May 19, 2015
Standards: 47 CFR FCC Part 15, Subpart E (Section 15.407)
ANSI C63.10:2009

The above equipment has been tested by **Bureau Veritas Consumer Products Services (H.K.) Ltd., Taoyuan Branch**, and found compliance with the requirement of the above standards. The test record, data evaluation & Equipment Under Test (EUT) configurations represented herein are true and accurate accounts of the measurements of the sample's EMC characteristics under the conditions specified in this report.

Prepared by : Celine Chou , **Date:** May 21, 2015
Celine Chou / Specialist

Approved by : Ken Liu , **Date:** May 21, 2015
Ken Liu / Senior Manager

2 Summary of Test Results

47 CFR FCC Part 15, Subpart E (Section 15.407 Under Old Rule)			
FCC Clause	Test Item	Result	Remarks
15.407(b)(6)	AC Power Conducted Emission	Pass	Meet the requirement of limit. Minimum passing margin is -6.50dB at 0.29506MHz.
15.407(b/1/2/3) (b)(6)	Radiated Emissions	Pass	Meet the requirement of limit. Minimum passing margin is -2.7dB at 35.82MHz.
15.407(a/1/2)	Max Average Transmit Power	Pass	Meet the requirement of limit.
15.407(a)(6)	Peak Power Excursion	Pass	Meet the requirement of limit.
15.407(a/1/2)	Peak Power Spectral Density	Pass	Meet the requirement of limit.
15.407(g)	Frequency Stability	Pass	Meet the requirement of limit.
15.203	Antenna Requirement	Pass	Antenna connector is i-pex(MHF) not a standard connector.

2.1 Measurement Uncertainty

Where relevant, the following measurement uncertainty levels have been estimated for tests performed on the EUT:

The listed uncertainties are the worst case uncertainty for the entire range of measurement. Please note that the uncertainty values are provided for informational purposes only and are not used in determining the PASS/FAIL results.

Measurement	Frequency	Expanded Uncertainty (k=2) (\pm)
Conducted Emissions at mains ports0	150kHz ~ 30MHz	2.44 dB
Radiated Emissions up to 1 GHz	30MHz ~ 200MHz	3.59 dB
	200MHz ~ 1000MHz	3.60 dB
Radiated Emissions above 1 GHz	1GHz ~ 18GHz	2.29 dB
	18GHz ~ 40GHz	2.29 dB

2.2 Modification Record

There were no modifications required for compliance.

3 General Information

3.1 General Description of EUT

Product	Wireless Access Point
Brand	Open Mesh
Test Model	OM5P-AC
Status of EUT	Engineering sample
Power Supply Rating	DC Input 12 ~ 24V 12 ~ 24Vdc form POE 48Vdc form POE
Modulation Type	256QAM, 64QAM, 16QAM, QPSK, BPSK for OFDM
Modulation Technology	OFDM
Transfer Rate	802.11a: 54.0/ 48.0/ 36.0/ 24.0/ 18.0/ 12.0/ 9.0/ 6.0Mbps 802.11n: up to 300.0Mbps 802.11ac: up to 866.7Mbps
Operating Frequency	5180 ~ 5240MHz
Number of Channel	4 for 802.11a, 802.11n (20MHz), 802.11ac (20MHz) 2 for 802.11n (40MHz), 802.11ac (40MHz) 1 for 802.11ac (80MHz)
Output Power	49.586mW
Antenna Type	Refer to Note
Antenna Connector	Refer to Note
Accessory Device	N/A
Data Cable Supplied	N/A

Note:

1. The EUT incorporates a MIMO function. Physically, the EUT provides 2 completed transmitters and 2 receivers.

Band	Modulation Mode	TX Function
5GHz	802.11a	1TX (Fixed Ant. A)
	802.11n (20MHz)	2TX
	802.11n (40MHz)	2TX
	802.11ac (80MHz)	2TX

* For 802.11a: Antenna A was for the final test.

2. The EUT uses following antennas.

No.	Ant. Type	Connecter Type	Antenna Gain (dBi)
A	PIFA	i-pex(MHF)	2.9
B			3.38

3. The EUT consumes power from the following adapter and POE (for support unit only).

Adapter	
Brand	LEADER ELECTRONICS INC.
Model	MT12-Y120100-A1
Input Power	120Vac, 60Hz, 0.3A
Output Power	12Vdc, 1A
Power Line	1.5m cable without core attached on adapter

POE Board	
Brand	NA
Model	PE-1000IAF
Power Rating	48Vdc, 0.4A

POE's adapter	
Brand	UNIFIVE
Model	UIB336-4875
Input Power	100-240Vac, 50/60Hz, 0.9A
Output Power	48Vdc, 0.75A
Power Line	1.8m cable without core attached on adapter

3.2 Description of Test Modes

For 5180 ~ 5240MHz

4 channels are provided for 802.11a, 802.11n (20MHz), 802.11ac (20MHz):

Channel	Frequency	Channel	Frequency
36	5180 MHz	44	5220 MHz
40	5200 MHz	48	5240 MHz

2 channels are provided for 802.11n (40MHz), 802.11ac (40MHz):

Channel	Frequency	Channel	Frequency
38	5190 MHz	46	5230 MHz

1 channel is provided for 802.11ac (80MHz):

Channel	Frequency
42	5210MHz

3.2.1 Test Mode Applicability and Tested Channel Detail

EUT CONFIGURE MODE	APPLICABLE TO				DESCRIPTION
	RE \geq 1G	RE<1G	PLC	APCM	
A	√	√	√	√	Powered by adapter
B	-	√	√	-	Powered by POE

Where **RE \geq 1G**: Radiated Emission above 1GHz & Bandedge Measurement
RE<1G: Radiated Emission below 1GHz
PLC: Power Line Conducted Emission
APCM: Antenna Port Conducted Measurement

NOTE:

1. The EUT had been pre-tested on the positioned of each 3 axis. The worst case was found when positioned on **X-plane**.
2. "-" means no effect.

Radiated Emission Test (Above 1GHz):

- Pre-Scan has been conducted to determine the worst-case mode from all possible combinations between available modulations, data rates and antenna ports (if EUT with antenna diversity architecture).
- Following channel(s) was (were) selected for the final test as listed below.

EUT CONFIGURE MODE	MODE	FREQ. BAND (MHz)	AVAILABLE CHANNEL	TESTED CHANNEL	MODULATION TECHNOLOGY	MODULATION TYPE	DATA RATE (Mbps)
A	802.11a	5180-5240	36 to 48	36, 40, 48	OFDM	BPSK	6.0
A	802.11n (20MHz)		36 to 48	36, 40, 48	OFDM	BPSK	7.2
A	802.11n (40MHz)		38 to 46	38, 46	OFDM	BPSK	15.0
A	802.11ac (20MHz)		36 to 48	36, 40, 48	OFDM	BPSK	7.2
A	802.11ac (40MHz)		38 to 46	38, 46	OFDM	BPSK	15.0
A	802.11ac (80MHz)		42	42	OFDM	BPSK	58.5

Radiated Emission Test (Below 1GHz):

- Pre-Scan has been conducted to determine the worst-case mode from all possible combinations between available modulations, data rates and antenna ports (if EUT with antenna diversity architecture).
- Following channel(s) was (were) selected for the final test as listed below.

EUT CONFIGURE MODE	MODE	FREQ. BAND (MHz)	AVAILABLE CHANNEL	TESTED CHANNEL	MODULATION TECHNOLOGY	MODULATION TYPE	DATA RATE (Mbps)
A, B	802.11a	5180-5240	36 to 48	36	OFDM	BPSK	6.0

Power Line Conducted Emission Test:

- Pre-Scan has been conducted to determine the worst-case mode from all possible combinations between available modulations, data rates and antenna ports (if EUT with antenna diversity architecture).
- Following channel(s) was (were) selected for the final test as listed below.

EUT CONFIGURE MODE	MODE	FREQ. BAND (MHz)	AVAILABLE CHANNEL	TESTED CHANNEL	MODULATION TECHNOLOGY	MODULATION TYPE	DATA RATE (Mbps)
A, B	802.11a	5180-5240	36 to 48	36	OFDM	BPSK	6.0

Antenna Port Conducted Measurement:

- This item includes all test value of each mode, but only includes spectrum plot of worst value of each mode.
- Pre-Scan has been conducted to determine the worst-case mode from all possible combinations between available modulations, data rates and antenna ports (if EUT with antenna diversity architecture).
- Following channel(s) was (were) selected for the final test as listed below.

EUT CONFIGURE MODE	MODE	FREQ. BAND (MHz)	AVAILABLE CHANNEL	TESTED CHANNEL	MODULATION TECHNOLOGY	MODULATION TYPE	DATA RATE (Mbps)
A	802.11a	5180-5240	36 to 48	36, 40, 48	OFDM	BPSK	6.0
A	802.11n (20MHz)		36 to 48	36, 40, 48	OFDM	BPSK	7.2
A	802.11n (40MHz)		38 to 46	38, 46	OFDM	BPSK	15.0
A	802.11ac (20MHz)		36 to 48	36, 40, 48	OFDM	BPSK	7.2
A	802.11ac (40MHz)		38 to 46	38, 46	OFDM	BPSK	15.0
A	802.11ac (80MHz)		42	42	OFDM	BPSK	58.5

Test Condition:

APPLICABLE TO	ENVIRONMENTAL CONDITIONS	INPUT POWER	TESTED BY
RE \geq 1G	25deg. C, 65%RH	120Vac, 60Hz	Chris Lin
RE $<$ 1G	24deg. C, 64%RH	120Vac, 60Hz 48Vdc	Match Tsui
PLC	24deg. C, 64%RH	120Vac, 60Hz 48Vdc	Match Tsui
APCM	25deg. C, 60%RH	120Vac, 60Hz	Nick Hsu

3.3 Duty Cycle of Test Signal

MODULATION TYPE: BPSK

Duty cycle is < 98%, duty factor shall be considered.

802.11a: Duty cycle = $2.705/2.783 = 0.972$, Duty factor = $10 * \log(1/0.972) = 0.12$

802.11n (20MHz): Duty cycle = $2.514/2.599 = 0.967$, Duty factor = $10 * \log(1/0.967) = 0.14$

802.11n (40MHz): Duty cycle = $1.227/1.307 = 0.939$, Duty factor = $10 * \log(1/0.939) = 0.27$

802.11ac (20MHz): Duty cycle = $2.522/2.595 = 0.972$, Duty factor = $10 * \log(1/0.972) = 0.12$

802.11ac (40MHz): Duty cycle = $1.235/1.322 = 0.934$, Duty factor = $10 * \log(1/0.934) = 0.30$

802.11ac (80MHz): Duty cycle = $0.592/0.665 = 0.890$, Duty factor = $10 * \log(1/0.890) = 0.50$

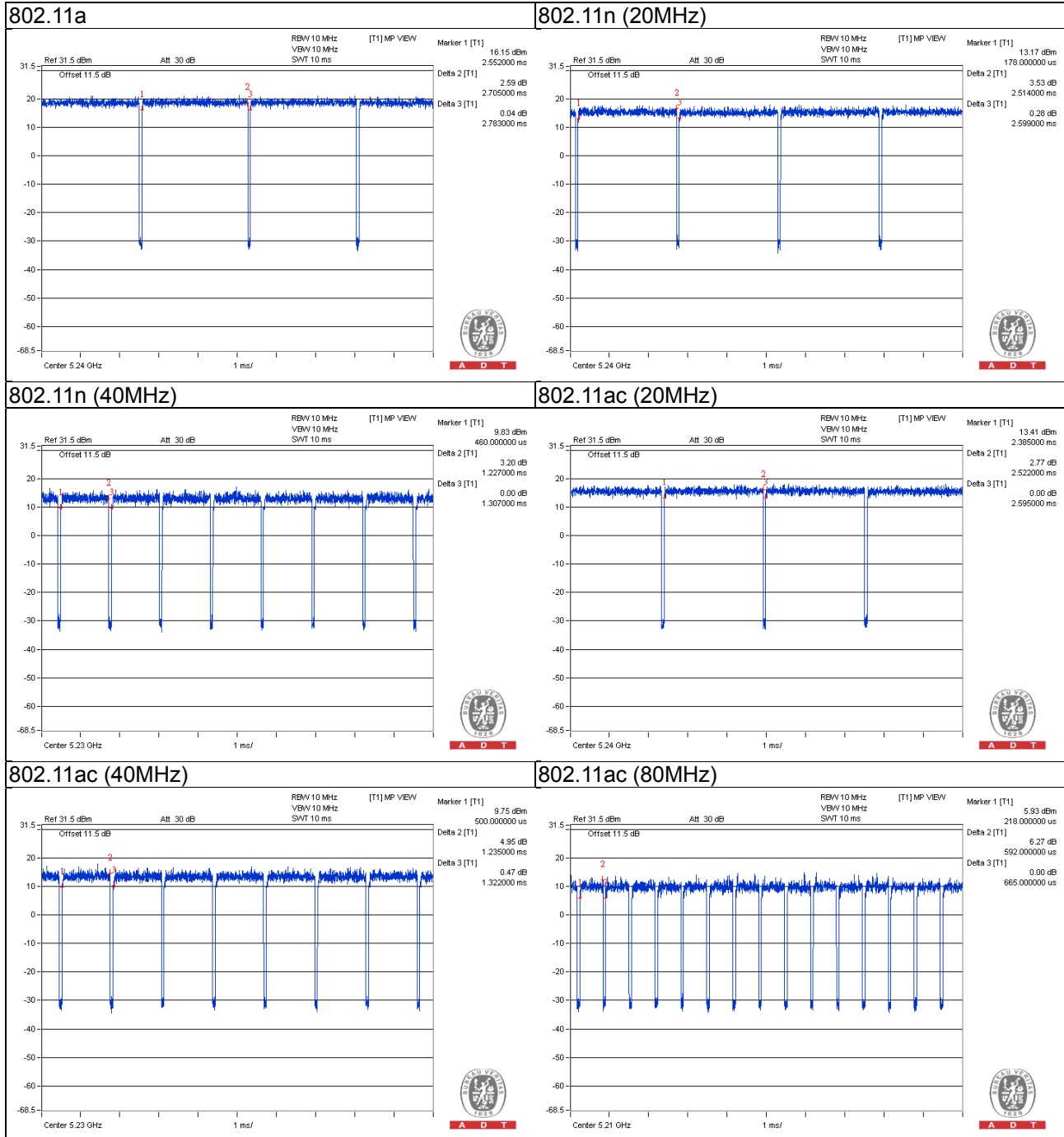

MODULATION TYPE: QPSK

Duty cycle is < 98%, duty factor shall be considered.

802.11a: Duty cycle = 1.364/1.439 = 0.948, Duty factor = $10 \cdot \log(1/0.948) = 0.23$

802.11n (20MHz): Duty cycle = 2.514/2.599 = 0.967, Duty factor = $10 \cdot \log(1/0.967) = 0.14$

802.11n (40MHz): Duty cycle = 0.632/0.719 = 0.879, Duty factor = $10 \cdot \log(1/0.879) = 0.56$

802.11ac (20MHz): Duty cycle = 1.277/1.357 = 0.941, Duty factor = $10 \cdot \log(1/0.941) = 0.26$

802.11ac (40MHz): Duty cycle = 0.637/0.717 = 0.888, Duty factor = $10 \cdot \log(1/0.888) = 0.51$

802.11ac (80MHz): Duty cycle = 0.320/0.410 = 0.780, Duty factor = $10 \cdot \log(1/0.780) = 1.08$



MODULATION TYPE: 16QAM

Duty cycle is < 98%, duty factor shall be considered.

802.11a: Duty cycle = 0.689/0.769 = 0.896, Duty factor = $10 * \log(1/0.896) = 0.48$

802.11n (20MHz): Duty cycle = 0.652/0.730 = 0.893, Duty factor = $10 * \log(1/0.893) = 0.49$

802.11n (40MHz): Duty cycle = 0.333/0.405 = 0.822, Duty factor = $10 * \log(1/0.822) = 0.85$

802.11ac (20MHz): Duty cycle = 0.664/0.744 = 0.892, Duty factor = $10 * \log(1/0.892) = 0.49$

802.11ac (40MHz): Duty cycle = 0.340/0.420 = 0.810, Duty factor = $10 * \log(1/0.810) = 0.92$

802.11ac (80MHz): Duty cycle = 0.175/0.247 = 0.709, Duty factor = $10 * \log(1/0.709) = 1.50$

802.11a **802.11n (20MHz)**

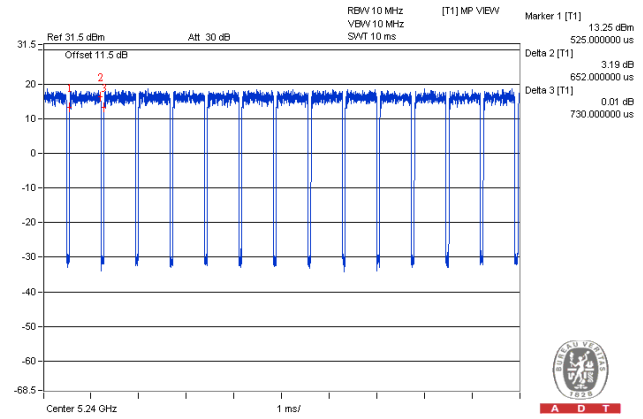
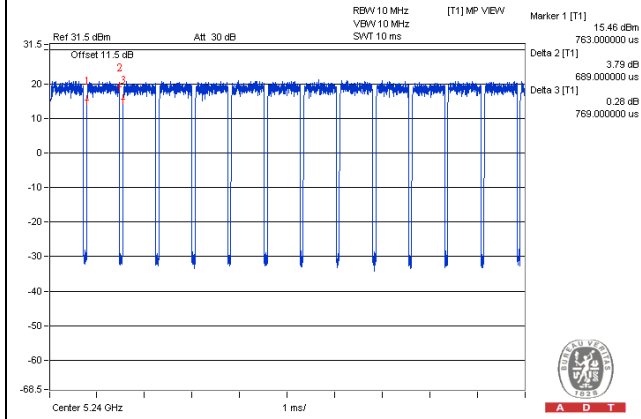

802.11n (40MHz) **802.11ac (20MHz)**

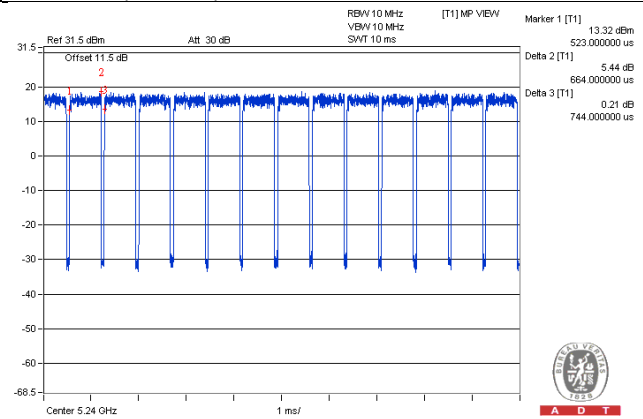
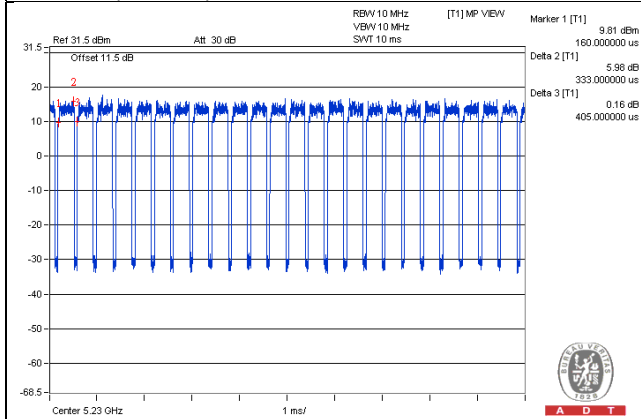

802.11ac (40MHz) **802.11ac (80MHz)**

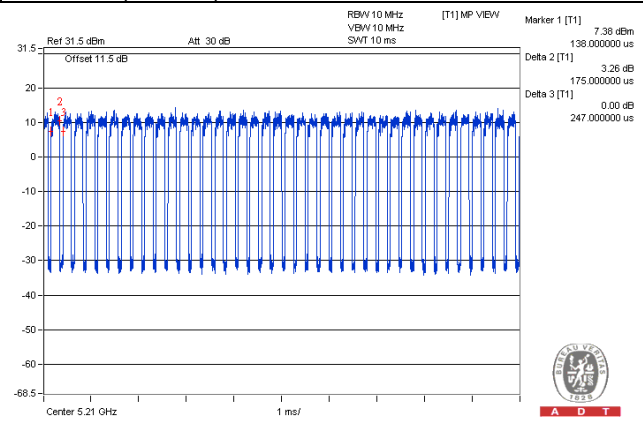
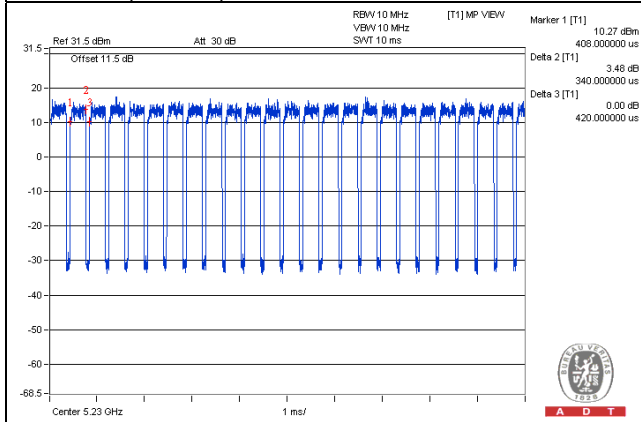

MODULATION TYPE: 64QAM

Duty cycle is < 98%, duty factor shall be considered.

802.11a: Duty cycle = 0.350/0.440 = 0.795, Duty factor = $10 * \log(1/0.795) = 0.99$

802.11n (20MHz): Duty cycle = 0.345/0.423 = 0.816, Duty factor = $10 * \log(1/0.816) = 0.89$

802.11n (40MHz): Duty cycle = 0.185/0.260 = 0.712, Duty factor = $10 * \log(1/0.712) = 1.48$

802.11ac (20MHz): Duty cycle = 0.342/0.417 = 0.820, Duty factor = $10 * \log(1/0.820) = 0.86$

802.11ac (40MHz): Duty cycle = 0.185/0.260 = 0.712, Duty factor = $10 * \log(1/0.712) = 1.48$

802.11ac (80MHz): Duty cycle = 0.102/0.180 = 0.567, Duty factor = $10 * \log(1/0.567) = 2.47$

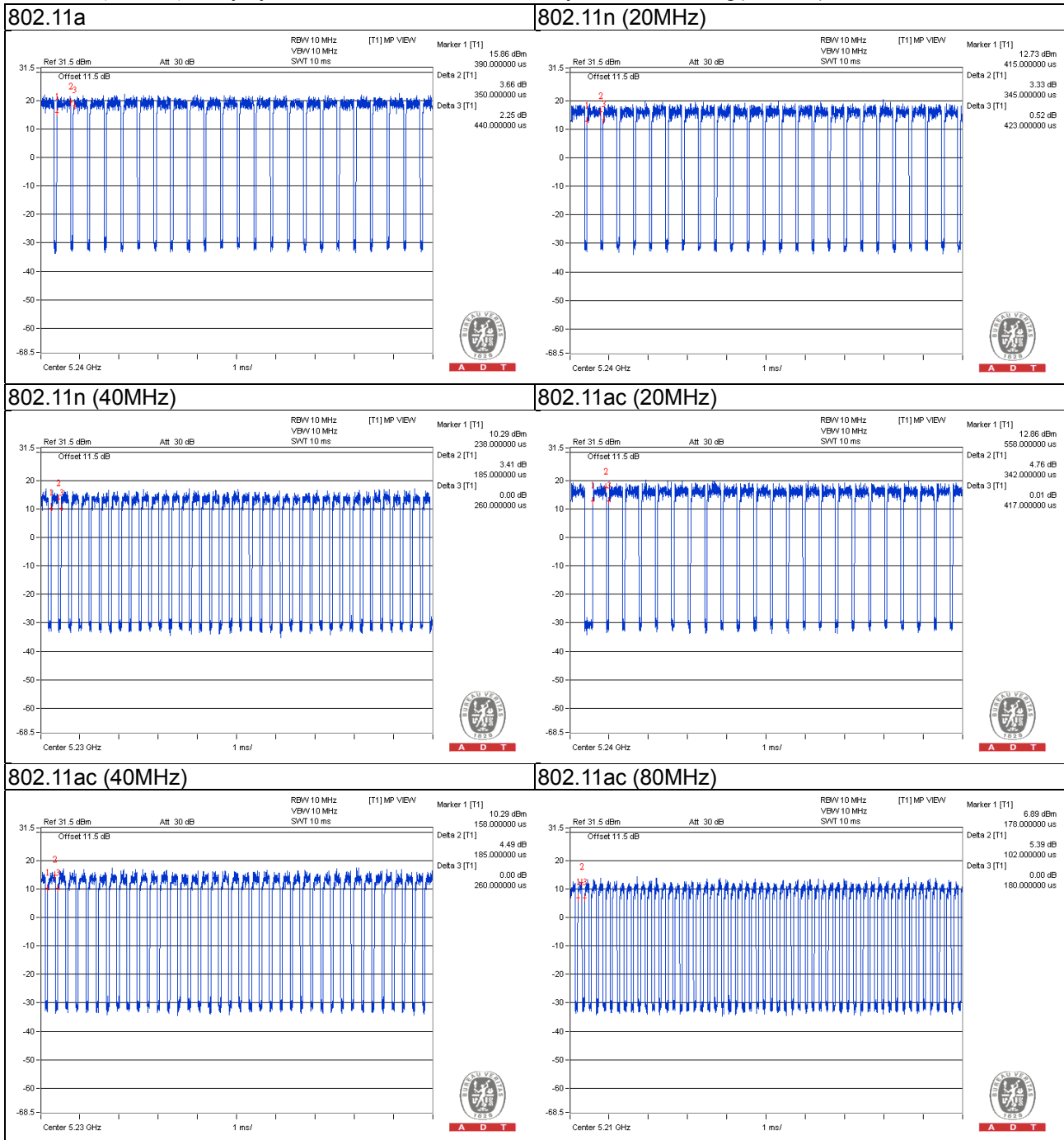

MODULATION TYPE: 256QAM

Duty cycle is < 98%, duty factor shall be considered.

802.11ac (20MHz): Duty cycle = 0.242/0.322 = 0.752, Duty factor = $10 * \log(1/0.752) = 1.24$

802.11ac (40MHz): Duty cycle = 0.133/0.208 = 0.639, Duty factor = $10 * \log(1/0.639) = 1.94$

802.11ac (80MHz): Duty cycle = 0.085/0.152 = 0.559, Duty factor = $10 * \log(1/0.559) = 2.52$

802.11ac (20MHz)

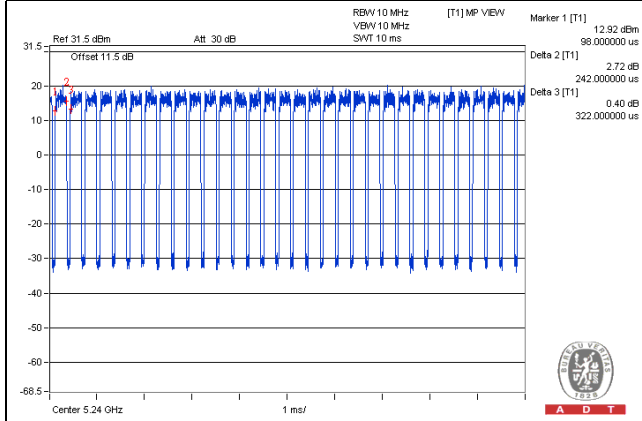

802.11ac (40MHz)

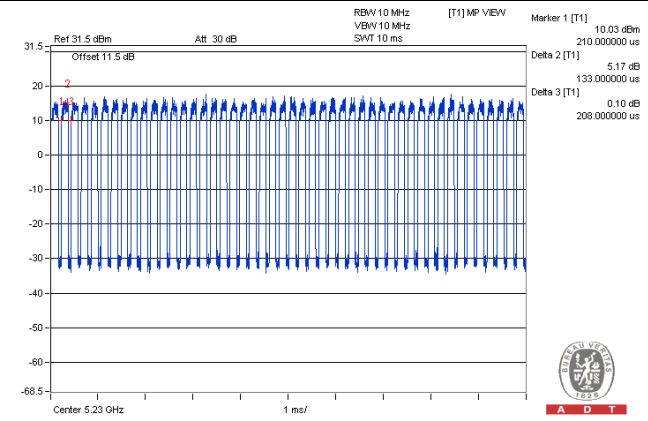

802.11ac (80MHz)

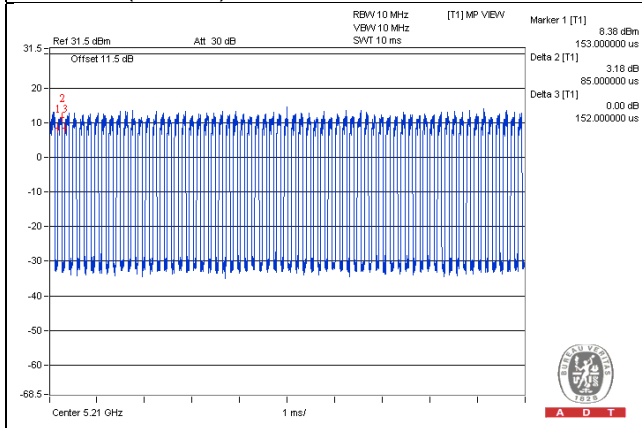

3.4 Description of Support Units

The EUT has been tested as an independent unit together with other necessary accessories or support units. The following support units or accessories were used to form a representative test configuration during the tests.

ID	Product	Brand	Model No.	Serial No.	FCC ID	Remarks
A.	Notebook	SONY	SVS151A12P	275548477000805	FCC DoC Approved	-
B.	Adapter	LEADER ELECTRONICS INC.	MT12-Y120100-A1	NA	NA	For test mode A only Provided by Manufacturer
C.	POE Board	NA	PE-1000IAF	NA	NA	For test mode B only Provided by Manufacturer
D.	POE's adapter	UNIFIVE	UIB336-4875	NA	NA	For test mode B only Provided by Manufacturer
E.	Load	NA	NA	NA	NA	-

Note:

1. All power cords of the above support units are non-shielded (1.8m).
2. Item A acted as communication partners to transfer data.

ID	Descriptions	Qty.	Length (m)	Shielding (Yes/No)	Cores (Qty.)	Remarks
1.	RJ45	1	3	N	0	-
2.	Power	1	1.5	N	0	For test mode A only Attached on adapter
		1	1.8	N	0	For test mode B only Attached on adapter
3.	RJ45	1	1.8	N	0	-
4.	RJ45	1	1.8	N	0	-

3.4.1 Configuration of System under Test

Test mode A

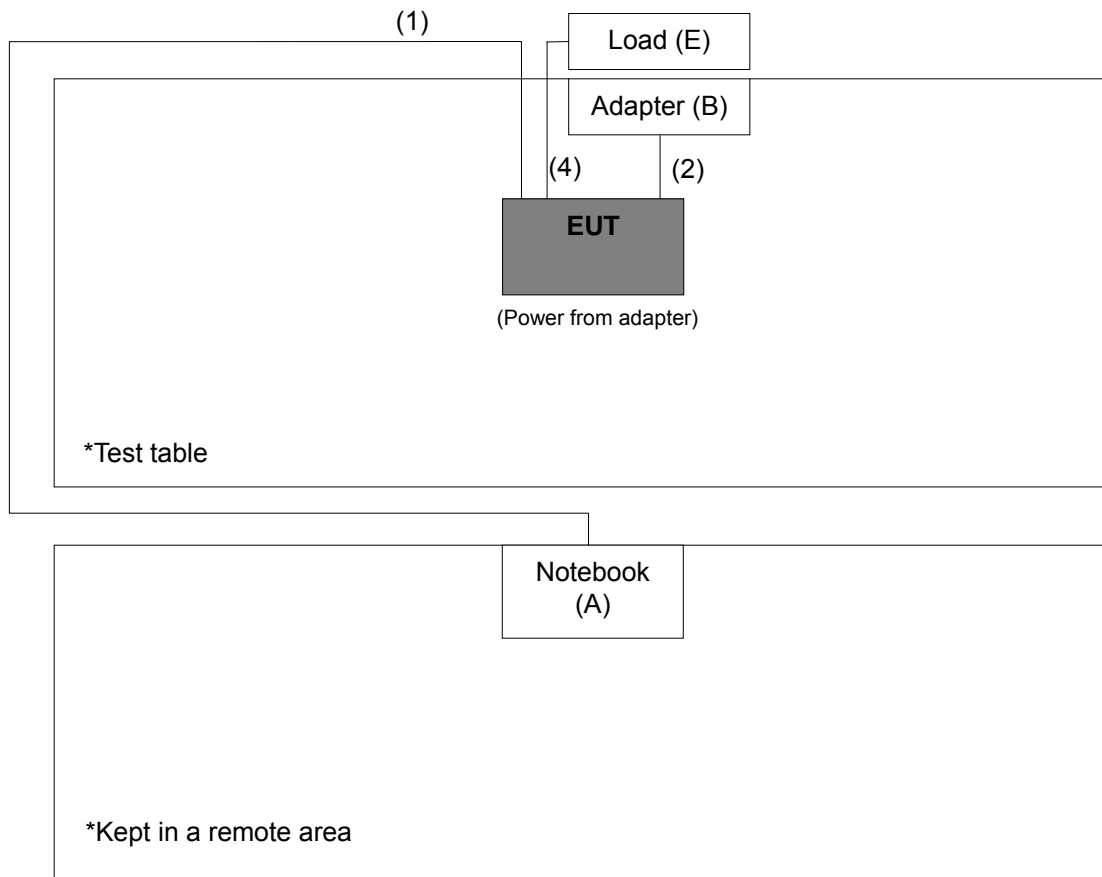

Test mode B

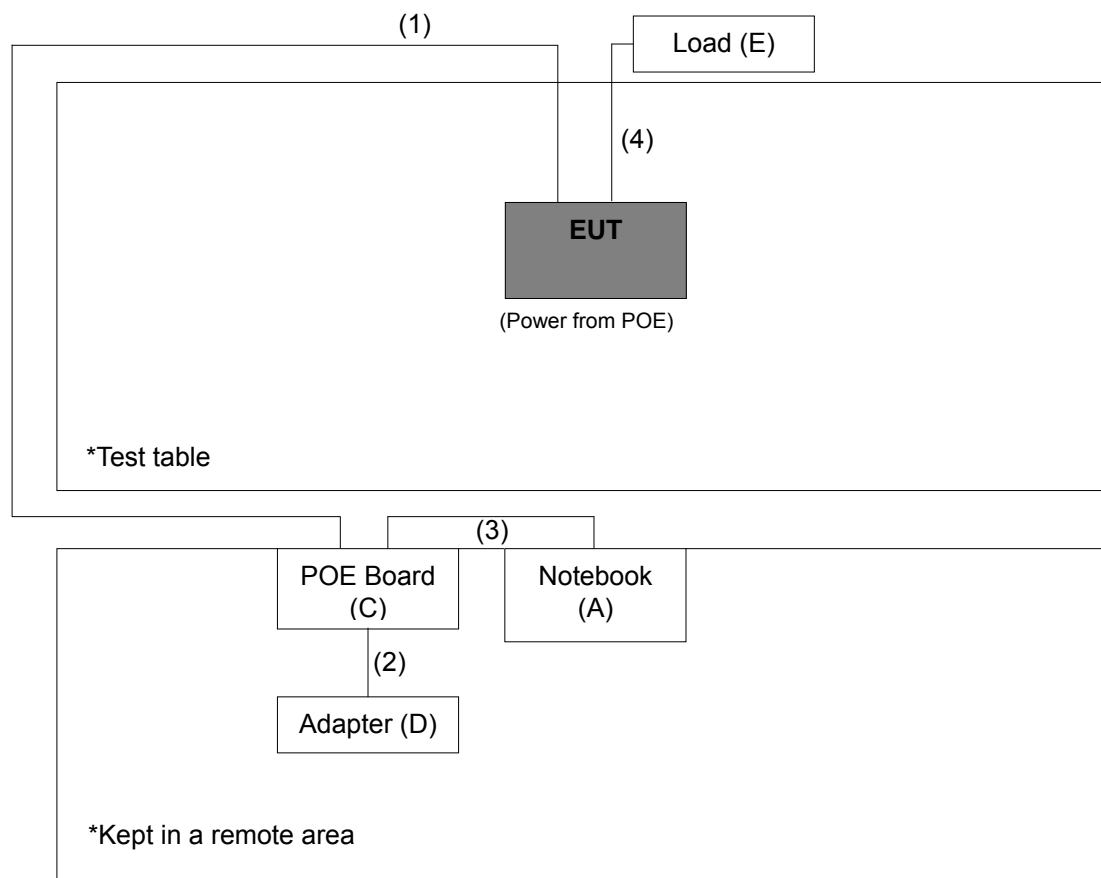

3.5 General Description of Applied Standards

The EUT is a RF Product. According to the specifications of the manufacturer, it must comply with the requirements of the following standards:

- FCC Part 15, Subpart E (15.407)**
- 789033 D01 General UNII Test Procedure Old Rules v01r04**
- 662911 D01 Multiple Transmitter Output v02r01**
- ANSI C63.10-2009

All test items have been performed and recorded as per the above standards.

Note: The EUT is also considered as a kind of computer peripheral, because the connection to computer is necessary for typical use. It has been verified to comply with the requirements of FCC Part 15, Subpart B, Class B (DoC). The test report has been issued separately.

4 Test Types and Results

4.1 Radiated Emission and Bandedge Measurement

4.1.1 Limits of Radiated Emission and Bandedge Measurement

Radiated emissions which fall in the restricted bands must comply with the radiated emission limits specified as below table. Other emissions shall be at least 20dB below the highest level of the desired power:

Frequencies (MHz)	Field Strength (microvolts/meter)	Measurement Distance (meters)
0.009 ~ 0.490	2400/F(kHz)	300
0.490 ~ 1.705	24000/F(kHz)	30
1.705 ~ 30.0	30	30
30 ~ 88	100	3
88 ~ 216	150	3
216 ~ 960	200	3
Above 960	500	3

NOTE:

1. The lower limit shall apply at the transition frequencies.
2. Emission level (dBuV/m) = 20 log Emission level (uV/m).
3. For frequencies above 1000MHz, the field strength limits are based on average detector, however, the peak field strength of any emission shall not exceed the maximum permitted average limits, specified above by more than 20dB under any condition of modulation.

LIMITS OF UNWANTED EMISSION OUT OF THE RESTRICTED BANDS

APPLICABLE TO	LIMIT	
789033 D01 General UNII Test Procedure Old Rules v01r04	FIELD STRENGTH AT 3m	
	PK:74 (dBuV/m)	AV:54 (dBuV/m)
APPLICABLE TO	EIRP LIMIT	EQUIVALENT FIELD STRENGTH AT 3m
15.407	PK:-27 (dBm/MHz)	PK:68.2(dBuV/m)

NOTE: ^{*1} beyond 10MHz of the band edge ^{*2} within 10 MHz of band edge

The following formula is used to convert the equipment isotropic radiated power (eirp) to field strength:

$$E = \frac{1000000 \cdot \sqrt{30P}}{3} \quad \mu\text{V/m, where } P \text{ is the eirp (Watts).}$$



4.1.2 Test Instruments

Description & Manufacturer	Model No.	Serial No.	Date of Calibration	Due Date of Calibration
Test Receiver ROHDE & SCHWARZ	ESCI	100424	Oct. 06, 2014	Oct. 05, 2015
Spectrum Analyzer ROHDE & SCHWARZ	FSP40	100040	Jul. 25, 2014	Jul. 24, 2015
BILOG Antenna SCHWARZBECK	VULB9168	9168-155	Feb. 06, 2015	Feb. 05, 2016
HORN Antenna SCHWARZBECK	BBHA 9120D	9120D-1170	Feb. 05, 2015	Feb. 04, 2016
HORN Antenna SCHWARZBECK	BBHA 9170	BBHA9170241	Feb. 09, 2015	Feb. 08, 2016
Preamplifier Agilent	8449B	3008A01960	Aug. 09, 2014	Aug. 08, 2015
Preamplifier Agilent	8447D	2944A10631	Aug. 09, 2014	Aug. 08, 2015
RF signal cable HUBER+SUHNNER	SUCOFLEX 104	309220/4	Aug. 09, 2014	Aug. 08, 2015
RF signal cable HUBER+SUHNNER	SUCOFLEX 104	250724/4	Aug. 09, 2014	Aug. 08, 2015
RF signal cable HUBER+SUHNNER	SUCOFLEX 104	295012/4	Aug. 09, 2014	Aug. 08, 2015
Software BV ADT	ADT_Radiated_ V7.6.15.9.4	NA	NA	NA
Antenna Tower inn-co GmbH	MA 4000	010303	NA	NA
Antenna Tower Controller BV ADT	AT100	AT93021703	NA	NA
Turn Table BV ADT	TT100	TT93021703	NA	NA
Turn Table Controller BV ADT	SC100.	SC93021703	NA	NA
26GHz ~ 40GHz Amplifier	EM26400	815221	Oct. 18, 2014	Oct. 17, 2015
High Speed Peak Power Meter	ML2495A	0824011	Jul. 26, 2014	Jul. 25, 2015
Power Sensor	MA2411B	0738171	Jul. 26, 2014	Jul. 25, 2015
WIT Standard Temperature And Humidity Chamber	TH-4S-C	W981030	Jun. 09, 2014	Jun. 08, 2015

- Note:**
1. The calibration interval of the above test instruments is 12 months and the calibrations are traceable to NML/ROC and NIST/USA.
 2. The test was performed in HwaYa Chamber 4.
 3. The horn antenna and HP preamplifier (model: 8449B) are used only for the measurement of emission frequency above 1GHz if tested.
 4. The FCC Site Registration No. is 460141.
 5. The IC Site Registration No. is IC7450F-4.

4.1.3 Test Procedures

- a. The EUT was placed on the top of a rotating table 0.8 meters above the ground at 3 meter chamber room for test. The table was rotated 360 degrees to determine the position of the highest radiation.
- b. The EUT was set 3 meters away from the interference-receiving antenna, which was mounted on the top of a variable-height antenna tower.
- c. The height of antenna is varied from one meter to four meters above the ground to determine the maximum value of the field strength. Both horizontal and vertical polarizations of the antenna are set to make the measurement.
- d. For each suspected emission, the EUT was arranged to its worst case and then the antenna was tuned to heights from 1 meter to 4 meters and the rotatable table was turned from 0 degrees to 360 degrees to find the maximum reading.
- e. The test-receiver system was set to quasi-peak detect function and specified bandwidth with maximum hold mode when the test frequency is below 1 GHz.
- f. The test-receiver system was set to peak and average detect function and specified bandwidth with maximum hold mode when the test frequency is above 1 GHz. If the peak reading value also meets average limit, measurement with the average detector is unnecessary.

Note:

1. For emission measurements above 1 GHz, the EUT shall be placed at a height of 1.5 m above the ground at 3 meter chamber room for test.
2. The resolution bandwidth and video bandwidth of test receiver/spectrum analyzer is 120kHz for Quasi-peak detection (QP) at frequency below 1GHz.
3. The resolution bandwidth of test receiver/spectrum analyzer is 1 MHz and the video bandwidth is 3 MHz for Peak detection (PK) at frequency above 1GHz.
4. The resolution bandwidth of test receiver/spectrum analyzer is 1MHz and the video bandwidth is 3MHz for RMS Average (Duty cycle < 98%) for Average detection (AV) at frequency above 1GHz, then the measurement results was added to a correction factor ($10 \log(1/\text{duty cycle})$).
5. The resolution bandwidth of test receiver/spectrum analyzer is 1MHz and the video bandwidth is 10Hz (Duty cycle \geq 98%) for Average detection (AV) at frequency above 1GHz.
6. All modes of operation were investigated and the worst-case emissions are reported.

4.1.4 Deviation from Test Standard

No deviation.

4.1.5 Test Set Up

<Frequency Range below 1GHz>

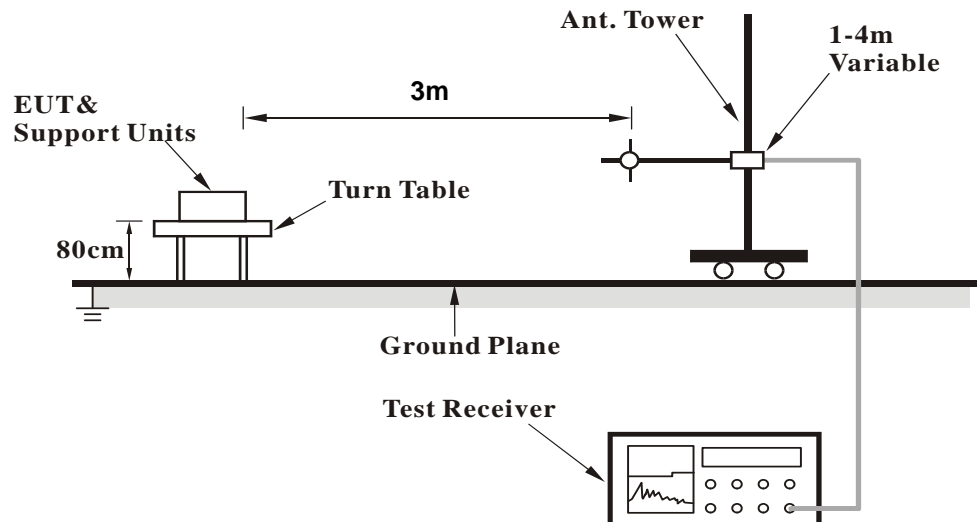

<Frequency Range above 1GHz>

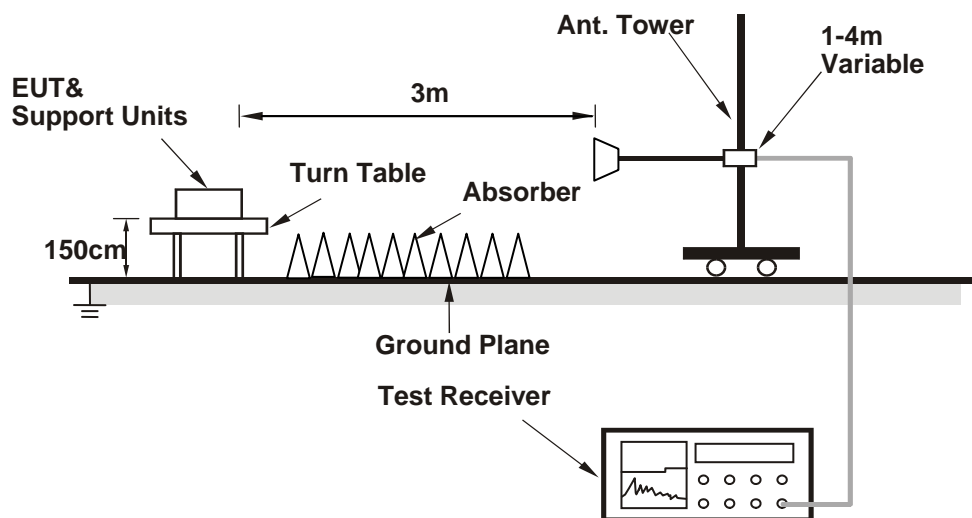

For the actual test configuration, please refer to the attached file (Test Setup Photo)

4.1.6 EUT Operating Conditions

- Placed the EUT on the testing table.
- Prepared a notebook to act as communication partner and placed it outside of testing area.
- The communication partner connected with EUT via a RJ45 cable and ran a test program (provided by manufacturer) to enable EUT under transmission condition continuously at specific channel frequency.
- The communication partner sent data to EUT by command "PING".

4.1.7 Test Results

Above 1GHz Data

802.11a

CHANNEL	TX Channel 36	DETECTOR FUNCTION	Peak (PK)
FREQUENCY RANGE	1GHz ~ 40GHz		Average (AV)

ANTENNA POLARITY & TEST DISTANCE: HORIZONTAL AT 3 M

NO.	FREQ. (MHz)	EMISSION LEVEL (dBuV/m)	LIMIT (dBuV/m)	MARGIN (dB)	ANTENNA HEIGHT (m)	TABLE ANGLE (Degree)	RAW VALUE (dBuV)	CORRECTION FACTOR (dB/m)
1	5150.00	57.3 PK	74.0	-16.7	1.00 H	216	52.00	5.30
2	5150.00	43.9 AV	54.0	-10.1	1.00 H	216	38.60	5.30
3	*5180.00	104.9 PK			1.00 H	216	65.70	39.20
4	*5180.00	95.4 AV			1.00 H	216	56.20	39.20
5	#10360.00	59.8 PK	74.0	-14.2	1.28 H	62	41.40	18.40
6	#10360.00	48.2 AV	54.0	-5.8	1.28 H	62	29.80	18.40

ANTENNA POLARITY & TEST DISTANCE: VERTICAL AT 3 M

NO.	FREQ. (MHz)	EMISSION LEVEL (dBuV/m)	LIMIT (dBuV/m)	MARGIN (dB)	ANTENNA HEIGHT (m)	TABLE ANGLE (Degree)	RAW VALUE (dBuV)	CORRECTION FACTOR (dB/m)
1	5150.00	58.4 PK	74.0	-15.6	1.00 V	302	53.10	5.30
2	5150.00	45.3 AV	54.0	-8.7	1.00 V	302	40.00	5.30
3	*5180.00	109.5 PK			1.00 V	302	70.30	39.20
4	*5180.00	100.8 AV			1.00 V	302	61.60	39.20
5	#10360.00	61.9 PK	74.0	-12.1	1.00 V	19	43.50	18.40
6	#10360.00	50.4 AV	54.0	-3.6	1.00 V	19	32.00	18.40

Remarks:

1. Emission Level(dBuV/m) = Raw Value(dBuV) + Correction Factor(dB/m)
2. Correction Factor(dB/m) = Antenna Factor(dB/m) + Cable Factor(dB)
3. The other emission levels were very low against the limit.
4. Margin value = Emission Level – Limit value
5. " * ": Fundamental frequency.
6. " # ": The radiated frequency is out of the restricted band.

CHANNEL	TX Channel 40	DETECTOR FUNCTION	Peak (PK)
FREQUENCY RANGE	1GHz ~ 40GHz		Average (AV)

ANTENNA POLARITY & TEST DISTANCE: HORIZONTAL AT 3 M

NO.	FREQ. (MHz)	EMISSION LEVEL (dBuV/m)	LIMIT (dBuV/m)	MARGIN (dB)	ANTENNA HEIGHT (m)	TABLE ANGLE (Degree)	RAW VALUE (dBuV)	CORRECTION FACTOR (dB/m)
1	*5200.00	104.6 PK			1.00 H	297	65.30	39.30
2	*5200.00	94.9 AV			1.00 H	297	55.60	39.30
3	#10400.00	60.1 PK	74.0	-13.9	1.15 H	98	41.90	18.20
4	#10400.00	46.9 AV	54.0	-7.1	1.15 H	98	28.70	18.20

ANTENNA POLARITY & TEST DISTANCE: VERTICAL AT 3 M

NO.	FREQ. (MHz)	EMISSION LEVEL (dBuV/m)	LIMIT (dBuV/m)	MARGIN (dB)	ANTENNA HEIGHT (m)	TABLE ANGLE (Degree)	RAW VALUE (dBuV)	CORRECTION FACTOR (dB/m)
1	*5200.00	109.8 PK			1.07 V	297	70.50	39.30
2	*5200.00	99.9 AV			1.07 V	297	60.60	39.30
3	#10400.00	62.7 PK	74.0	-11.3	1.14 V	28	44.50	18.20
4	#10400.00	51.0 AV	54.0	-3.0	1.14 V	28	32.80	18.20

Remarks:

1. Emission Level(dBuV/m) = Raw Value(dBuV) + Correction Factor(dB/m)
2. Correction Factor(dB/m) = Antenna Factor(dB/m) + Cable Factor(dB)
3. The other emission levels were very low against the limit.
4. Margin value = Emission Level – Limit value
5. " * ": Fundamental frequency.
6. " # ": The radiated frequency is out of the restricted band.

CHANNEL	TX Channel 48	DETECTOR FUNCTION	Peak (PK)
FREQUENCY RANGE	1GHz ~ 40GHz		Average (AV)

ANTENNA POLARITY & TEST DISTANCE: HORIZONTAL AT 3 M

NO.	FREQ. (MHz)	EMISSION LEVEL (dBuV/m)	LIMIT (dBuV/m)	MARGIN (dB)	ANTENNA HEIGHT (m)	TABLE ANGLE (Degree)	RAW VALUE (dBuV)	CORRECTION FACTOR (dB/m)
1	*5240.00	103.5 PK			1.14 H	297	64.20	39.30
2	*5240.00	93.8 AV			1.14 H	297	54.50	39.30
3	5350.00	55.9 PK	74.0	-18.1	1.14 H	297	50.30	5.60
4	5350.00	42.8 AV	54.0	-11.2	1.14 H	297	37.20	5.60
5	#10480.00	59.5 PK	74.0	-14.5	1.19 H	292	41.90	17.60
6	#10480.00	47.2 AV	54.0	-6.8	1.19 H	292	29.60	17.60

ANTENNA POLARITY & TEST DISTANCE: VERTICAL AT 3 M

NO.	FREQ. (MHz)	EMISSION LEVEL (dBuV/m)	LIMIT (dBuV/m)	MARGIN (dB)	ANTENNA HEIGHT (m)	TABLE ANGLE (Degree)	RAW VALUE (dBuV)	CORRECTION FACTOR (dB/m)
1	*5240.00	110.1 PK			1.15 V	297	70.80	39.30
2	*5240.00	100.1 AV			1.15 V	297	60.80	39.30
3	5350.00	55.9 PK	74.0	-18.1	1.15 V	297	50.30	5.60
4	5350.00	43.4 AV	54.0	-10.6	1.15 V	297	37.80	5.60
5	#10480.00	62.6 PK	74.0	-11.4	1.20 V	27	45.00	17.60
6	#10480.00	51.1 AV	54.0	-2.9	1.20 V	27	33.50	17.60

Remarks:

1. Emission Level(dBuV/m) = Raw Value(dBuV) + Correction Factor(dB/m)
2. Correction Factor(dB/m) = Antenna Factor(dB/m) + Cable Factor(dB)
3. The other emission levels were very low against the limit.
4. Margin value = Emission Level – Limit value
5. " * ": Fundamental frequency.
6. " # ": The radiated frequency is out of the restricted band.

802.11n (20MHz)

CHANNEL	TX Channel 36	DETECTOR	Peak (PK)
FREQUENCY RANGE	1GHz ~ 40GHz	FUNCTION	Average (AV)

ANTENNA POLARITY & TEST DISTANCE: HORIZONTAL AT 3 M

NO.	FREQ. (MHz)	EMISSION LEVEL (dBuV/m)	LIMIT (dBuV/m)	MARGIN (dB)	ANTENNA HEIGHT (m)	TABLE ANGLE (Degree)	RAW VALUE (dBuV)	CORRECTION FACTOR (dB/m)
1	5150.00	55.4 PK	74.0	-18.6	1.10 H	20	50.10	5.30
2	5150.00	44.3 AV	54.0	-9.7	1.10 H	20	39.00	5.30
3	*5180.00	100.0 PK			1.00 H	303	60.80	39.20
4	*5180.00	90.7 AV			1.00 H	303	51.50	39.20
5	#10360.00	61.4 PK	74.0	-12.6	1.55 H	226	43.00	18.40
6	#10360.00	48.3 AV	54.0	-5.7	1.55 H	226	29.90	18.40

ANTENNA POLARITY & TEST DISTANCE: VERTICAL AT 3 M

NO.	FREQ. (MHz)	EMISSION LEVEL (dBuV/m)	LIMIT (dBuV/m)	MARGIN (dB)	ANTENNA HEIGHT (m)	TABLE ANGLE (Degree)	RAW VALUE (dBuV)	CORRECTION FACTOR (dB/m)
1	5150.00	55.7 PK	74.0	-18.3	1.20 V	112	50.40	5.30
2	5150.00	43.2 AV	54.0	-10.8	1.20 V	112	37.90	5.30
3	*5180.00	107.1 PK			1.01 V	301	67.90	39.20
4	*5180.00	96.8 AV			1.01 V	301	57.60	39.20
5	#10360.00	61.2 PK	74.0	-12.8	1.10 V	306	42.80	18.40
6	#10360.00	48.4 AV	54.0	-5.6	1.10 V	306	30.00	18.40

Remarks:

1. Emission Level(dBuV/m) = Raw Value(dBuV) + Correction Factor(dB/m)
2. Correction Factor(dB/m) = Antenna Factor(dB/m) + Cable Factor(dB)
3. The other emission levels were very low against the limit.
4. Margin value = Emission Level – Limit value
5. " * ": Fundamental frequency.
6. " # ": The radiated frequency is out of the restricted band.

CHANNEL	TX Channel 40	DETECTOR FUNCTION	Peak (PK)
FREQUENCY RANGE	1GHz ~ 40GHz		Average (AV)

ANTENNA POLARITY & TEST DISTANCE: HORIZONTAL AT 3 M

NO.	FREQ. (MHz)	EMISSION LEVEL (dBuV/m)	LIMIT (dBuV/m)	MARGIN (dB)	ANTENNA HEIGHT (m)	TABLE ANGLE (Degree)	RAW VALUE (dBuV)	CORRECTION FACTOR (dB/m)
1	*5200.00	100.3 PK			1.50 H	298	61.00	39.30
2	*5200.00	90.6 AV			1.50 H	298	51.30	39.30
3	#10400.00	61.8 PK	74.0	-12.2	1.17 H	48	43.60	18.20
4	#10400.00	46.9 AV	54.0	-7.1	1.17 H	48	28.70	18.20

ANTENNA POLARITY & TEST DISTANCE: VERTICAL AT 3 M

NO.	FREQ. (MHz)	EMISSION LEVEL (dBuV/m)	LIMIT (dBuV/m)	MARGIN (dB)	ANTENNA HEIGHT (m)	TABLE ANGLE (Degree)	RAW VALUE (dBuV)	CORRECTION FACTOR (dB/m)
1	*5200.00	107.1 PK			1.00 V	298	67.80	39.30
2	*5200.00	97.5 AV			1.00 V	298	58.20	39.30
3	#10400.00	61.8 PK	74.0	-12.2	1.26 V	9	43.60	18.20
4	#10400.00	48.1 AV	54.0	-5.9	1.26 V	9	29.90	18.20

Remarks:

1. Emission Level(dBuV/m) = Raw Value(dBuV) + Correction Factor(dB/m)
2. Correction Factor(dB/m) = Antenna Factor(dB/m) + Cable Factor(dB)
3. The other emission levels were very low against the limit.
4. Margin value = Emission Level – Limit value
5. " * ": Fundamental frequency.
6. " # ": The radiated frequency is out of the restricted band.

CHANNEL	TX Channel 48	DETECTOR FUNCTION	Peak (PK)
FREQUENCY RANGE	1GHz ~ 40GHz		Average (AV)

ANTENNA POLARITY & TEST DISTANCE: HORIZONTAL AT 3 M

NO.	FREQ. (MHz)	EMISSION LEVEL (dBuV/m)	LIMIT (dBuV/m)	MARGIN (dB)	ANTENNA HEIGHT (m)	TABLE ANGLE (Degree)	RAW VALUE (dBuV)	CORRECTION FACTOR (dB/m)
1	*5240.00	101.5 PK			1.00 H	11	62.20	39.30
2	*5240.00	92.2 AV			1.00 H	11	52.90	39.30
3	5350.00	55.7 PK	74.0	-18.3	1.10 H	30	50.10	5.60
4	5350.00	44.3 AV	54.0	-9.7	1.10 H	30	38.70	5.60
5	#10480.00	56.5 PK	74.0	-17.5	1.39 H	87	38.90	17.60
6	#10480.00	46.6 AV	54.0	-7.4	1.39 H	87	29.00	17.60

ANTENNA POLARITY & TEST DISTANCE: VERTICAL AT 3 M

NO.	FREQ. (MHz)	EMISSION LEVEL (dBuV/m)	LIMIT (dBuV/m)	MARGIN (dB)	ANTENNA HEIGHT (m)	TABLE ANGLE (Degree)	RAW VALUE (dBuV)	CORRECTION FACTOR (dB/m)
1	*5240.00	108.7 PK			1.07 V	301	69.40	39.30
2	*5240.00	98.1 AV			1.07 V	301	58.80	39.30
3	5350.00	55.9 PK	74.0	-18.1	1.10 V	310	50.30	5.60
4	5350.00	44.6 AV	54.0	-9.4	1.10 V	310	39.00	5.60
5	#10480.00	60.6 PK	74.0	-13.4	1.15 V	74	43.00	17.60
6	#10480.00	47.5 AV	54.0	-6.5	1.15 V	74	29.90	17.60

Remarks:

1. Emission Level(dBuV/m) = Raw Value(dBuV) + Correction Factor(dB/m)
2. Correction Factor(dB/m) = Antenna Factor(dB/m) + Cable Factor(dB)
3. The other emission levels were very low against the limit.
4. Margin value = Emission Level – Limit value
5. " * ": Fundamental frequency.
6. " # ": The radiated frequency is out of the restricted band.

802.11n (40MHz)

CHANNEL	TX Channel 38	DETECTOR	Peak (PK)
FREQUENCY RANGE	1GHz ~ 40GHz	FUNCTION	Average (AV)

ANTENNA POLARITY & TEST DISTANCE: HORIZONTAL AT 3 M

NO.	FREQ. (MHz)	EMISSION LEVEL (dBuV/m)	LIMIT (dBuV/m)	MARGIN (dB)	ANTENNA HEIGHT (m)	TABLE ANGLE (Degree)	RAW VALUE (dBuV)	CORRECTION FACTOR (dB/m)
1	5150.00	56.9 PK	74.0	-17.1	1.42 H	215	51.60	5.30
2	5150.00	44.6 AV	54.0	-9.4	1.42 H	215	39.30	5.30
3	*5190.00	98.9 PK			1.49 H	218	59.70	39.20
4	*5190.00	88.6 AV			1.49 H	218	49.40	39.20
5	#10380.00	59.6 PK	74.0	-14.4	1.00 H	67	41.40	18.20
6	#10380.00	47.4 AV	54.0	-6.6	1.00 H	67	29.20	18.20

ANTENNA POLARITY & TEST DISTANCE: VERTICAL AT 3 M

NO.	FREQ. (MHz)	EMISSION LEVEL (dBuV/m)	LIMIT (dBuV/m)	MARGIN (dB)	ANTENNA HEIGHT (m)	TABLE ANGLE (Degree)	RAW VALUE (dBuV)	CORRECTION FACTOR (dB/m)
1	5150.00	60.6 PK	74.0	-13.4	1.00 V	297	55.30	5.30
2	5150.00	46.7 AV	54.0	-7.3	1.00 V	297	41.40	5.30
3	*5190.00	104.7 PK			1.00 V	303	65.50	39.20
4	*5190.00	95.1 AV			1.00 V	303	55.90	39.20
5	#10380.00	61.0 PK	74.0	-13.0	1.00 V	314	42.80	18.20
6	#10380.00	48.0 AV	54.0	-6.0	1.00 V	314	29.80	18.20

Remarks:

1. Emission Level(dBuV/m) = Raw Value(dBuV) + Correction Factor(dB/m)
2. Correction Factor(dB/m) = Antenna Factor(dB/m) + Cable Factor(dB)
3. The other emission levels were very low against the limit.
4. Margin value = Emission Level – Limit value
5. " * ": Fundamental frequency.
6. " # ": The radiated frequency is out of the restricted band.

CHANNEL	TX Channel 46	DETECTOR FUNCTION	Peak (PK)
FREQUENCY RANGE	1GHz ~ 40GHz		Average (AV)

ANTENNA POLARITY & TEST DISTANCE: HORIZONTAL AT 3 M

NO.	FREQ. (MHz)	EMISSION LEVEL (dBuV/m)	LIMIT (dBuV/m)	MARGIN (dB)	ANTENNA HEIGHT (m)	TABLE ANGLE (Degree)	RAW VALUE (dBuV)	CORRECTION FACTOR (dB/m)
1	*5230.00	99.2 PK			1.03 H	295	59.90	39.30
2	*5230.00	89.3 AV			1.03 H	295	50.00	39.30
3	5350.00	55.4 PK	74.0	-18.6	1.02 H	290	49.80	5.60
4	5350.00	44.1 AV	54.0	-9.9	1.02 H	290	38.50	5.60
5	#10460.00	59.1 PK	74.0	-14.9	1.00 H	72	41.40	17.70
6	#10460.00	46.3 AV	54.0	-7.7	1.00 H	72	28.60	17.70

ANTENNA POLARITY & TEST DISTANCE: VERTICAL AT 3 M

NO.	FREQ. (MHz)	EMISSION LEVEL (dBuV/m)	LIMIT (dBuV/m)	MARGIN (dB)	ANTENNA HEIGHT (m)	TABLE ANGLE (Degree)	RAW VALUE (dBuV)	CORRECTION FACTOR (dB/m)
1	*5230.00	105.6 PK			1.05 V	295	66.30	39.30
2	*5230.00	95.1 AV			1.05 V	295	55.80	39.30
3	5350.00	58.3 PK	74.0	-15.7	1.07 V	296	52.70	5.60
4	5350.00	45.5 AV	54.0	-8.5	1.07 V	296	39.90	5.60
5	#10460.00	60.1 PK	74.0	-13.9	1.00 V	21	42.40	17.70
6	#10460.00	47.4 AV	54.0	-6.6	1.00 V	21	29.70	17.70

Remarks:

1. Emission Level(dBuV/m) = Raw Value(dBuV) + Correction Factor(dB/m)
2. Correction Factor(dB/m) = Antenna Factor(dB/m) + Cable Factor(dB)
3. The other emission levels were very low against the limit.
4. Margin value = Emission Level – Limit value
5. " * ": Fundamental frequency.
6. " # ": The radiated frequency is out of the restricted band.

802.11ac (20MHz)

CHANNEL	TX Channel 36	DETECTOR	Peak (PK)
FREQUENCY RANGE	1GHz ~ 40GHz	FUNCTION	Average (AV)

ANTENNA POLARITY & TEST DISTANCE: HORIZONTAL AT 3 M

NO.	FREQ. (MHz)	EMISSION LEVEL (dBuV/m)	LIMIT (dBuV/m)	MARGIN (dB)	ANTENNA HEIGHT (m)	TABLE ANGLE (Degree)	RAW VALUE (dBuV)	CORRECTION FACTOR (dB/m)
1	5150.00	55.9 PK	74.0	-18.1	1.01 H	2	50.60	5.30
2	5150.00	44.7 AV	54.0	-9.3	1.01 H	2	39.40	5.30
3	*5180.00	101.0 PK			1.00 H	320	61.80	39.20
4	*5180.00	91.2 AV			1.00 H	320	52.00	39.20
5	#10360.00	61.5 PK	74.0	-12.5	1.50 H	268	43.10	18.40
6	#10360.00	48.8 AV	54.0	-5.2	1.50 H	268	30.40	18.40

ANTENNA POLARITY & TEST DISTANCE: VERTICAL AT 3 M

NO.	FREQ. (MHz)	EMISSION LEVEL (dBuV/m)	LIMIT (dBuV/m)	MARGIN (dB)	ANTENNA HEIGHT (m)	TABLE ANGLE (Degree)	RAW VALUE (dBuV)	CORRECTION FACTOR (dB/m)
1	5150.00	56.2 PK	74.0	-17.8	1.10 V	110	50.90	5.30
2	5150.00	44.1 AV	54.0	-9.9	1.10 V	110	38.80	5.30
3	*5180.00	108.0 PK			1.02 V	312	68.80	39.20
4	*5180.00	97.4 AV			1.02 V	312	58.20	39.20
5	#10360.00	62.0 PK	74.0	-12.0	1.00 V	310	43.60	18.40
6	#10360.00	49.0 AV	54.0	-5.0	1.00 V	310	30.60	18.40

Remarks:

1. Emission Level(dBuV/m) = Raw Value(dBuV) + Correction Factor(dB/m)
2. Correction Factor(dB/m) = Antenna Factor(dB/m) + Cable Factor(dB)
3. The other emission levels were very low against the limit.
4. Margin value = Emission Level – Limit value
5. " * ": Fundamental frequency.
6. " # ": The radiated frequency is out of the restricted band.

CHANNEL	TX Channel 40	DETECTOR FUNCTION	Peak (PK)
FREQUENCY RANGE	1GHz ~ 40GHz		Average (AV)

ANTENNA POLARITY & TEST DISTANCE: HORIZONTAL AT 3 M

NO.	FREQ. (MHz)	EMISSION LEVEL (dBuV/m)	LIMIT (dBuV/m)	MARGIN (dB)	ANTENNA HEIGHT (m)	TABLE ANGLE (Degree)	RAW VALUE (dBuV)	CORRECTION FACTOR (dB/m)
1	*5200.00	101.1 PK			1.05 H	278	61.80	39.30
2	*5200.00	91.4 AV			1.05 H	278	52.10	39.30
3	#10400.00	62.2 PK	74.0	-11.8	1.08 H	82	44.00	18.20
4	#10400.00	47.5 AV	54.0	-6.5	1.08 H	82	29.30	18.20

ANTENNA POLARITY & TEST DISTANCE: VERTICAL AT 3 M

NO.	FREQ. (MHz)	EMISSION LEVEL (dBuV/m)	LIMIT (dBuV/m)	MARGIN (dB)	ANTENNA HEIGHT (m)	TABLE ANGLE (Degree)	RAW VALUE (dBuV)	CORRECTION FACTOR (dB/m)
1	*5200.00	107.9 PK			1.00 V	287	68.60	39.30
2	*5200.00	98.2 AV			1.00 V	287	58.90	39.30
3	#10400.00	62.4 PK	74.0	-11.6	1.28 V	19	44.20	18.20
4	#10400.00	49.0 AV	54.0	-5.0	1.28 V	19	30.80	18.20

Remarks:

1. Emission Level(dBuV/m) = Raw Value(dBuV) + Correction Factor(dB/m)
2. Correction Factor(dB/m) = Antenna Factor(dB/m) + Cable Factor(dB)
3. The other emission levels were very low against the limit.
4. Margin value = Emission Level – Limit value
5. " * ": Fundamental frequency.
6. " # ": The radiated frequency is out of the restricted band.

CHANNEL	TX Channel 48	DETECTOR FUNCTION	Peak (PK)
FREQUENCY RANGE	1GHz ~ 40GHz		Average (AV)

ANTENNA POLARITY & TEST DISTANCE: HORIZONTAL AT 3 M

NO.	FREQ. (MHz)	EMISSION LEVEL (dBuV/m)	LIMIT (dBuV/m)	MARGIN (dB)	ANTENNA HEIGHT (m)	TABLE ANGLE (Degree)	RAW VALUE (dBuV)	CORRECTION FACTOR (dB/m)
1	*5240.00	102.4 PK			1.00 H	22	63.10	39.30
2	*5240.00	93.1 AV			1.00 H	22	53.80	39.30
3	5350.00	56.2 PK	74.0	-17.8	1.03 H	10	50.60	5.60
4	5350.00	45.0 AV	54.0	-9.0	1.03 H	10	39.40	5.60
5	#10480.00	57.4 PK	74.0	-16.6	1.32 H	72	39.80	17.60
6	#10480.00	47.4 AV	54.0	-6.6	1.32 H	72	29.80	17.60

ANTENNA POLARITY & TEST DISTANCE: VERTICAL AT 3 M

NO.	FREQ. (MHz)	EMISSION LEVEL (dBuV/m)	LIMIT (dBuV/m)	MARGIN (dB)	ANTENNA HEIGHT (m)	TABLE ANGLE (Degree)	RAW VALUE (dBuV)	CORRECTION FACTOR (dB/m)
1	*5240.00	109.5 PK			1.01 V	307	70.20	39.30
2	*5240.00	98.9 AV			1.01 V	307	59.60	39.30
3	5350.00	56.4 PK	74.0	-17.6	1.01 V	304	50.80	5.60
4	5350.00	45.0 AV	54.0	-9.0	1.01 V	304	39.40	5.60
5	#10480.00	61.4 PK	74.0	-12.6	1.11 V	41	43.80	17.60
6	#10480.00	48.4 AV	54.0	-5.6	1.11 V	41	30.80	17.60

Remarks:

1. Emission Level(dBuV/m) = Raw Value(dBuV) + Correction Factor(dB/m)
2. Correction Factor(dB/m) = Antenna Factor(dB/m) + Cable Factor(dB)
3. The other emission levels were very low against the limit.
4. Margin value = Emission Level – Limit value
5. " * ": Fundamental frequency.
6. " # ": The radiated frequency is out of the restricted band.

802.11ac (40MHz)

CHANNEL	TX Channel 38	DETECTOR	Peak (PK)
FREQUENCY RANGE	1GHz ~ 40GHz	FUNCTION	Average (AV)

ANTENNA POLARITY & TEST DISTANCE: HORIZONTAL AT 3 M

NO.	FREQ. (MHz)	EMISSION LEVEL (dBuV/m)	LIMIT (dBuV/m)	MARGIN (dB)	ANTENNA HEIGHT (m)	TABLE ANGLE (Degree)	RAW VALUE (dBuV)	CORRECTION FACTOR (dB/m)
1	5150.00	57.7 PK	74.0	-16.3	1.42 H	213	52.40	5.30
2	5150.00	45.2 AV	54.0	-8.8	1.42 H	213	39.90	5.30
3	*5190.00	99.7 PK			1.41 H	216	60.50	39.20
4	*5190.00	89.3 AV			1.41 H	216	50.10	39.20
5	#10380.00	60.2 PK	74.0	-13.8	1.00 H	73	42.00	18.20
6	#10380.00	48.1 AV	54.0	-5.9	1.00 H	73	29.90	18.20

ANTENNA POLARITY & TEST DISTANCE: VERTICAL AT 3 M

NO.	FREQ. (MHz)	EMISSION LEVEL (dBuV/m)	LIMIT (dBuV/m)	MARGIN (dB)	ANTENNA HEIGHT (m)	TABLE ANGLE (Degree)	RAW VALUE (dBuV)	CORRECTION FACTOR (dB/m)
1	5150.00	60.9 PK	74.0	-13.1	1.00 V	276	55.60	5.30
2	5150.00	47.1 AV	54.0	-6.9	1.00 V	276	41.80	5.30
3	*5190.00	105.2 PK			1.00 V	307	66.00	39.20
4	*5190.00	95.6 AV			1.00 V	307	56.40	39.20
5	#10380.00	61.7 PK	74.0	-12.3	1.00 V	345	43.50	18.20
6	#10380.00	49.0 AV	54.0	-5.0	1.00 V	345	30.80	18.20

Remarks:

1. Emission Level(dBuV/m) = Raw Value(dBuV) + Correction Factor(dB/m)
2. Correction Factor(dB/m) = Antenna Factor(dB/m) + Cable Factor(dB)
3. The other emission levels were very low against the limit.
4. Margin value = Emission Level – Limit value
5. " * ": Fundamental frequency.
6. " # ": The radiated frequency is out of the restricted band.

CHANNEL	TX Channel 46	DETECTOR FUNCTION	Peak (PK)
FREQUENCY RANGE	1GHz ~ 40GHz		Average (AV)

ANTENNA POLARITY & TEST DISTANCE: HORIZONTAL AT 3 M

NO.	FREQ. (MHz)	EMISSION LEVEL (dBuV/m)	LIMIT (dBuV/m)	MARGIN (dB)	ANTENNA HEIGHT (m)	TABLE ANGLE (Degree)	RAW VALUE (dBuV)	CORRECTION FACTOR (dB/m)
1	*5230.00	99.8 PK			1.04 H	283	60.50	39.30
2	*5230.00	90.0 AV			1.04 H	283	50.70	39.30
3	5350.00	56.2 PK	74.0	-17.8	1.00 H	299	50.60	5.60
4	5350.00	44.6 AV	54.0	-9.4	1.00 H	299	39.00	5.60
5	#10460.00	59.7 PK	74.0	-14.3	1.00 H	29	42.00	17.70
6	#10460.00	47.0 AV	54.0	-7.0	1.00 H	29	29.30	17.70

ANTENNA POLARITY & TEST DISTANCE: VERTICAL AT 3 M

NO.	FREQ. (MHz)	EMISSION LEVEL (dBuV/m)	LIMIT (dBuV/m)	MARGIN (dB)	ANTENNA HEIGHT (m)	TABLE ANGLE (Degree)	RAW VALUE (dBuV)	CORRECTION FACTOR (dB/m)
1	*5230.00	106.1 PK			1.04 V	284	66.80	39.30
2	*5230.00	95.9 AV			1.04 V	284	56.60	39.30
3	5350.00	59.0 PK	74.0	-15.0	1.01 V	265	53.40	5.60
4	5350.00	46.4 AV	54.0	-7.6	1.01 V	265	40.80	5.60
5	#10460.00	60.9 PK	74.0	-13.1	1.00 V	13	43.20	17.70
6	#10460.00	48.2 AV	54.0	-5.8	1.00 V	13	30.50	17.70

Remarks:

1. Emission Level(dBuV/m) = Raw Value(dBuV) + Correction Factor(dB/m)
2. Correction Factor(dB/m) = Antenna Factor(dB/m) + Cable Factor(dB)
3. The other emission levels were very low against the limit.
4. Margin value = Emission Level – Limit value
5. " * ": Fundamental frequency.
6. " # ": The radiated frequency is out of the restricted band.

802.11ac (80MHz)

CHANNEL	TX Channel 42	DETECTOR	Peak (PK)
FREQUENCY RANGE	1GHz ~ 40GHz	FUNCTION	Average (AV)

ANTENNA POLARITY & TEST DISTANCE: HORIZONTAL AT 3 M

NO.	FREQ. (MHz)	EMISSION LEVEL (dBuV/m)	LIMIT (dBuV/m)	MARGIN (dB)	ANTENNA HEIGHT (m)	TABLE ANGLE (Degree)	RAW VALUE (dBuV)	CORRECTION FACTOR (dB/m)
1	5150.00	63.4 PK	74.0	-10.6	1.07 H	296	58.10	5.30
2	5150.00	45.9 AV	54.0	-8.1	1.07 H	296	40.60	5.30
3	*5210.00	96.6 PK			1.03 H	296	57.30	39.30
4	*5210.00	86.1 AV			1.03 H	296	46.80	39.30
5	#10420.00	59.2 PK	74.0	-14.8	1.00 H	61	41.20	18.00
6	#10420.00	46.9 AV	54.0	-7.1	1.00 H	61	28.90	18.00

ANTENNA POLARITY & TEST DISTANCE: VERTICAL AT 3 M

NO.	FREQ. (MHz)	EMISSION LEVEL (dBuV/m)	LIMIT (dBuV/m)	MARGIN (dB)	ANTENNA HEIGHT (m)	TABLE ANGLE (Degree)	RAW VALUE (dBuV)	CORRECTION FACTOR (dB/m)
1	5150.00	61.9 PK	74.0	-12.1	1.07 V	79	56.60	5.30
2	5150.00	48.4 AV	54.0	-5.6	1.07 V	79	43.10	5.30
3	*5210.00	102.1 PK			1.05 V	296	62.80	39.30
4	*5210.00	92.0 AV			1.05 V	296	52.70	39.30
5	#10420.00	60.3 PK	74.0	-13.7	1.00 V	311	42.30	18.00
6	#10420.00	47.7 AV	54.0	-6.3	1.00 V	311	29.70	18.00

Remarks:

1. Emission Level(dBuV/m) = Raw Value(dBuV) + Correction Factor(dB/m)
2. Correction Factor(dB/m) = Antenna Factor(dB/m) + Cable Factor(dB)
3. The other emission levels were very low against the limit.
4. Margin value = Emission Level – Limit value
5. " * ": Fundamental frequency.
6. " # ": The radiated frequency is out of the restricted band.

Below 1GHz Data

802.11a

CHANNEL	TX Channel 36	DETECTOR FUNCTION	Quasi-Peak (QP)
FREQUENCY RANGE	30MHz ~ 1GHz		
TEST MODE	A		

ANTENNA POLARITY & TEST DISTANCE: HORIZONTAL AT 3 M

NO.	FREQ. (MHz)	EMISSION LEVEL (dBuV/m)	LIMIT (dBuV/m)	MARGIN (dB)	ANTENNA HEIGHT (m)	TABLE ANGLE (Degree)	RAW VALUE (dBuV)	CORRECTION FACTOR (dB/m)
1	299.66	31.5 QP	46.0	-14.5	1.00 H	101	44.11	-12.57
2	600.36	28.5 QP	46.0	-17.5	1.50 H	191	34.85	-6.34
3	769.14	28.1 QP	46.0	-17.9	1.50 H	8	31.03	-2.95
4	825.40	39.7 QP	46.0	-6.3	1.00 H	269	42.14	-2.41
5	901.06	32.4 QP	46.0	-13.6	1.70 H	160	33.67	-1.31
6	908.82	29.7 QP	46.0	-16.4	1.00 H	26	30.71	-1.06

ANTENNA POLARITY & TEST DISTANCE: VERTICAL AT 3 M

NO.	FREQ. (MHz)	EMISSION LEVEL (dBuV/m)	LIMIT (dBuV/m)	MARGIN (dB)	ANTENNA HEIGHT (m)	TABLE ANGLE (Degree)	RAW VALUE (dBuV)	CORRECTION FACTOR (dB/m)
1	59.10	25.9 QP	40.0	-14.1	1.00 V	296	40.60	-14.67
2	173.56	28.1 QP	43.5	-15.4	1.00 V	303	42.64	-14.57
3	299.66	32.1 QP	46.0	-13.9	1.50 V	220	44.63	-12.57
4	361.74	31.5 QP	46.0	-14.5	1.00 V	185	42.85	-11.39
5	825.40	38.9 QP	46.0	-7.1	1.50 V	13	41.34	-2.41
6	901.06	35.8 QP	46.0	-10.2	1.50 V	11	37.11	-1.31

Remarks:

1. Emission Level(dBuV/m) = Raw Value(dBuV) + Correction Factor(dB/m)
2. Correction Factor(dB/m) = Antenna Factor(dB/m) + Cable Factor(dB)
3. The other emission levels were very low against the limit.
4. Margin value = Emission Level – Limit value

CHANNEL	TX Channel 36	DETECTOR FUNCTION	Quasi-Peak (QP)
FREQUENCY RANGE	30MHz ~ 1GHz		
TEST MODE	B		

ANTENNA POLARITY & TEST DISTANCE: HORIZONTAL AT 3 M

NO.	FREQ. (MHz)	EMISSION LEVEL (dBuV/m)	LIMIT (dBuV/m)	MARGIN (dB)	ANTENNA HEIGHT (m)	TABLE ANGLE (Degree)	RAW VALUE (dBuV)	CORRECTION FACTOR (dB/m)
1	30.00	28.0 QP	40.0	-12.0	1.50 H	16	43.83	-15.80
2	72.68	32.2 QP	40.0	-7.8	1.99 H	103	49.22	-16.98
3	185.20	35.5 QP	43.5	-8.0	1.50 H	80	51.38	-15.90
4	299.66	35.5 QP	46.0	-10.6	2.00 H	115	48.02	-12.57
5	365.62	31.6 QP	46.0	-14.4	2.00 H	139	42.91	-11.30
6	658.56	30.3 QP	46.0	-15.7	1.50 H	140	35.80	-5.51

ANTENNA POLARITY & TEST DISTANCE: VERTICAL AT 3 M

NO.	FREQ. (MHz)	EMISSION LEVEL (dBuV/m)	LIMIT (dBuV/m)	MARGIN (dB)	ANTENNA HEIGHT (m)	TABLE ANGLE (Degree)	RAW VALUE (dBuV)	CORRECTION FACTOR (dB/m)
1	35.82	37.3 QP	40.0	-2.7	1.00 V	37	52.88	-15.61
2	72.68	36.6 QP	40.0	-3.4	1.00 V	222	53.62	-16.98
3	127.00	31.1 QP	43.5	-12.4	1.00 V	88	47.04	-15.91
4	134.76	29.6 QP	43.5	-13.9	1.00 V	171	44.62	-15.06
5	189.08	34.2 QP	43.5	-9.3	1.00 V	341	50.50	-16.28
6	299.66	32.5 QP	46.0	-13.5	1.00 V	182	45.11	-12.57

Remarks:

1. Emission Level(dBuV/m) = Raw Value(dBuV) + Correction Factor(dB/m)
2. Correction Factor(dB/m) = Antenna Factor(dB/m) + Cable Factor(dB)
3. The other emission levels were very low against the limit.
4. Margin value = Emission Level – Limit value

4.2 Conducted Emission Measurement

4.2.1 Limits of Conducted Emission Measurement

Frequency (MHz)	Conducted Limit (dBuV)	
	Quasi-peak	Average
0.15 - 0.5	66 - 56	56 - 46
0.50 - 5.0	56	46
5.0 - 30.0	60	50

- Note:** 1. The lower limit shall apply at the transition frequencies.
 2. The limit decreases in line with the logarithm of the frequency in the range of 0.15 to 0.50MHz.

4.2.2 Test Instruments

Description & Manufacturer	Model No.	Serial No.	Date of Calibration	Due Date of Calibration
Test Receiver ROHDE & SCHWARZ	ESCI	100613	Nov. 11, 2014	Nov. 10, 2015
RF signal cable Woken	5D-FB	Cable-HYC01-01	Dec. 26, 2014	Dec. 25, 2015
LISN ROHDE & SCHWARZ (EUT)	ESH3-Z5	835239/001	Mar. 02, 2015	Mar. 01, 2016
LISN ROHDE & SCHWARZ (Peripheral)	ESH3-Z5	100311	Jul. 21, 2014	Jul. 20, 2015
Software ADT	BV ADT_Cond_ V7.3.7.3	NA	NA	NA

- Note:** 1. The calibration interval of the above test instruments is 12 months and the calibrations are traceable to NML/ROC and NIST/USA.
 2. The test was performed in HwaYa Shielded Room 1.
 3. The VCCI Site Registration No. is C-2040.

4.2.3 Test Procedures

- The EUT was placed 0.4 meters from the conducting wall of the shielded room with EUT being connected to the power mains through a line impedance stabilization network (LISN). Other support units were connected to the power mains through another LISN. The two LISNs provide 50 ohm/ 50uH of coupling impedance for the measuring instrument.
- Both lines of the power mains connected to the EUT were checked for maximum conducted interference.
- The frequency range from 150kHz to 30MHz was searched. Emission levels under (Limit - 20dB) was not recorded.

NOTE: The resolution bandwidth and video bandwidth of test receiver is 9kHz for quasi-peak detection (QP) and average detection (AV) at frequency 0.15MHz-30MHz.

4.2.4 Deviation from Test Standard

No deviation.

4.2.5 Test Setup

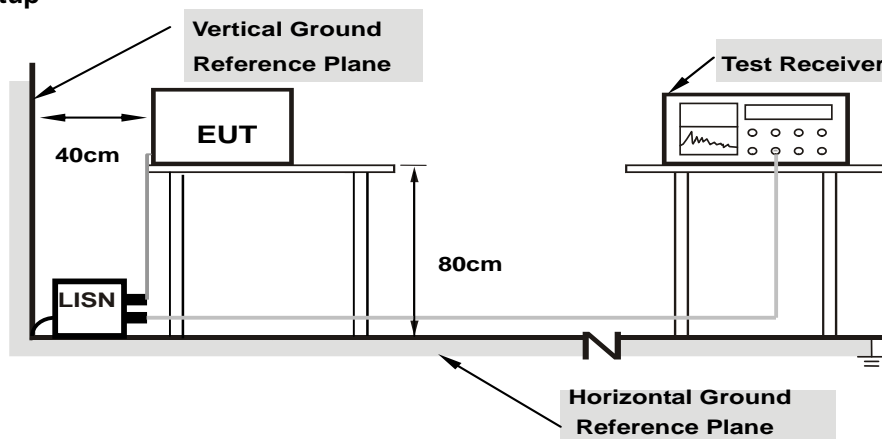

Note: 1.Support units were connected to second LISN.

For the actual test configuration, please refer to the attached file (Test Setup Photo).

4.2.6 EUT Operating Conditions

Same as 4.1.6.

4.2.7 Test Results

Phase	Line (L)	Detector Function	Quasi-Peak (QP) / Average (AV)
Test mode	A		

No	Freq. [MHz]	Corr. Factor (dB)	Reading Value [dB (uV)]		Emission Level [dB (uV)]		Limit [dB (uV)]		Margin (dB)	
			Q.P.	AV.	Q.P.	AV.	Q.P.	AV.	Q.P.	AV.
			1	0.18128	0.06	35.68	26.74	35.74	26.80	64.43
2	0.25192	0.06	35.30	25.00	35.36	25.06	61.69	51.69	-26.33	-26.63
3	0.41979	0.06	33.35	22.39	33.41	22.45	57.45	47.45	-24.04	-25.00
4	0.73233	0.07	32.36	20.97	32.43	21.04	56.00	46.00	-23.57	-24.96
5	1.01020	0.08	29.17	19.63	29.25	19.71	56.00	46.00	-26.75	-26.29
6	8.18896	0.37	20.19	9.60	20.56	9.97	60.00	50.00	-39.44	-40.03

Remarks:

1. Q.P. and AV. are abbreviations of quasi-peak and average individually.
2. The emission levels of other frequencies were very low against the limit.
3. Margin value = Emission level - Limit value
4. Correction factor = Insertion loss + Cable loss
5. Emission Level = Correction Factor + Reading Value.

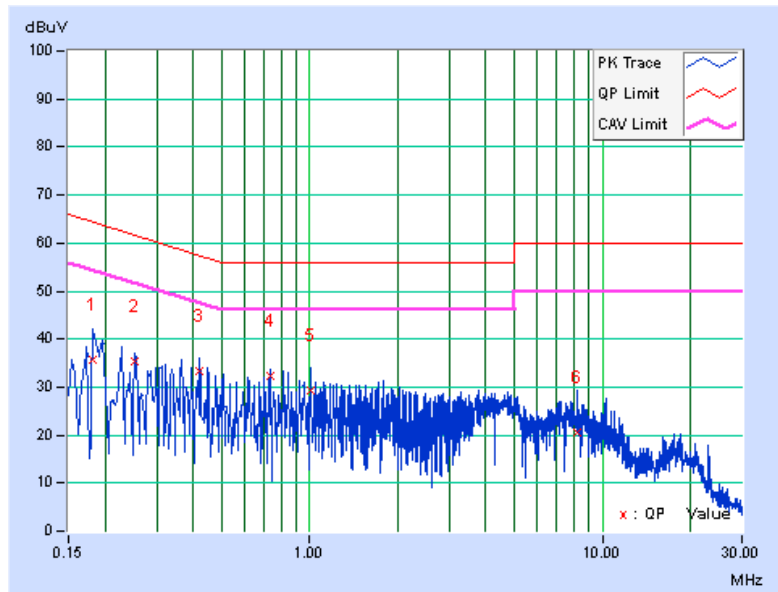

Phase	Neutral (N)	Detector Function	Quasi-Peak (QP) / Average (AV)
Test mode	A		

No	Freq. [MHz]	Corr. Factor (dB)	Reading Value [dB (uV)]		Emission Level [dB (uV)]		Limit [dB (uV)]		Margin (dB)	
			Q.P.	AV.	Q.P.	AV.	Q.P.	AV.	Q.P.	AV.
			1	0.17328	0.05	34.88	18.88	34.93	18.93	64.80
2	0.25166	0.05	32.66	15.17	32.71	15.22	61.70	51.70	-28.99	-36.48
3	0.29467	0.05	30.88	15.39	30.93	15.44	60.39	50.39	-29.46	-34.95
4	0.73233	0.07	33.31	16.15	33.38	16.22	56.00	46.00	-22.62	-29.78
5	1.57715	0.10	27.02	11.31	27.12	11.41	56.00	46.00	-28.88	-34.59
6	4.83027	0.22	28.14	11.34	28.36	11.56	56.00	46.00	-27.64	-34.44

Remarks:

1. Q.P. and AV. are abbreviations of quasi-peak and average individually.
2. The emission levels of other frequencies were very low against the limit.
3. Margin value = Emission level - Limit value
4. Correction factor = Insertion loss + Cable loss
5. Emission Level = Correction Factor + Reading Value.

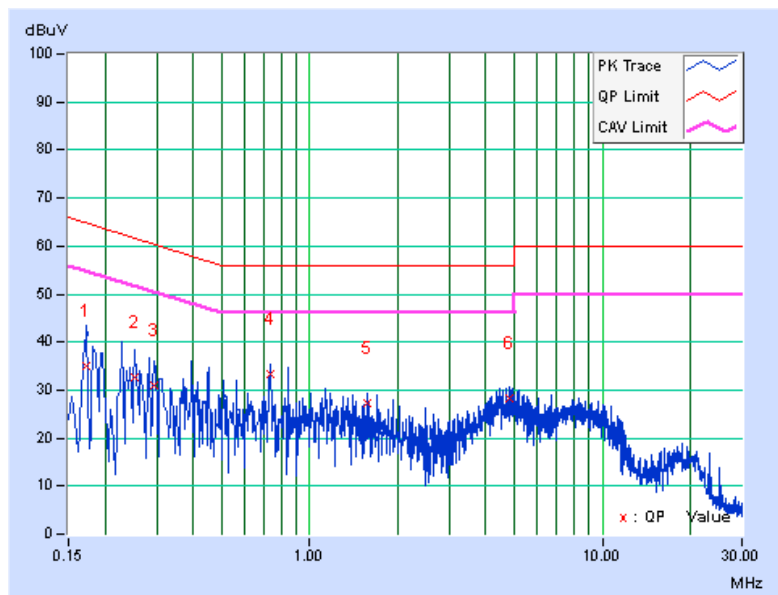

Phase	Line (L)	Detector Function	Quasi-Peak (QP) / Average (AV)
Test mode	B		

No	Freq. [MHz]	Corr. Factor (dB)	Reading Value [dB (uV)]		Emission Level [dB (uV)]		Limit [dB (uV)]		Margin (dB)	
			Q.P.	AV.	Q.P.	AV.	Q.P.	AV.	Q.P.	AV.
			1	0.18122	0.06	49.50	40.33	49.56	40.39	64.43
2	0.24775	0.06	52.06	41.93	52.12	41.99	61.83	51.83	-9.71	-9.84
3	0.29467	0.06	53.28	43.28	53.34	43.34	60.39	50.39	-7.05	-7.05
4	0.45889	0.06	41.78	24.83	41.84	24.89	56.71	46.71	-14.87	-21.82
5	0.58792	0.07	40.87	27.35	40.94	27.42	56.00	46.00	-15.06	-18.58
6	6.05801	0.28	35.69	29.78	35.97	30.06	60.00	50.00	-24.03	-19.94

Remarks:

1. Q.P. and AV. are abbreviations of quasi-peak and average individually.
2. The emission levels of other frequencies were very low against the limit.
3. Margin value = Emission level - Limit value
4. Correction factor = Insertion loss + Cable loss
5. Emission Level = Correction Factor + Reading Value.

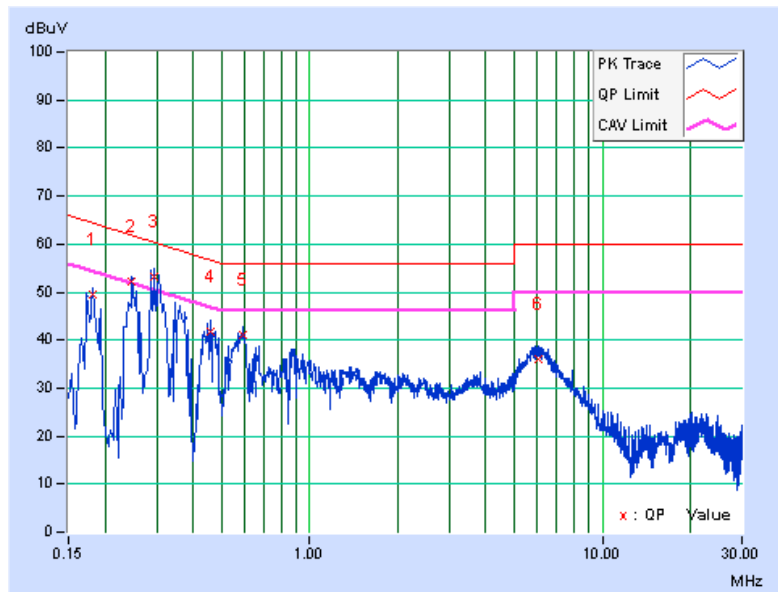

Phase	Neutral (N)	Detector Function	Quasi-Peak (QP) / Average (AV)
Test mode	B		

No	Freq. [MHz]	Corr. Factor (dB)	Reading Value [dB (uV)]		Emission Level [dB (uV)]		Limit [dB (uV)]		Margin (dB)	
			Q.P.	AV.	Q.P.	AV.	Q.P.	AV.	Q.P.	AV.
			1	0.18519	0.05	48.40	38.84	48.45	38.89	64.25
2	0.25391	0.05	53.02	40.86	53.07	40.91	61.63	51.63	-8.56	-10.72
3	0.29506	0.05	53.83	43.75	53.88	43.80	60.38	50.38	-6.50	-6.58
4	0.45107	0.06	40.90	23.36	40.96	23.42	56.86	46.86	-15.89	-23.43
5	0.58792	0.07	39.89	26.26	39.96	26.33	56.00	46.00	-16.04	-19.67
6	5.70611	0.26	33.41	28.43	33.67	28.69	60.00	50.00	-26.33	-21.31

Remarks:

1. Q.P. and AV. are abbreviations of quasi-peak and average individually.
2. The emission levels of other frequencies were very low against the limit.
3. Margin value = Emission level - Limit value
4. Correction factor = Insertion loss + Cable loss
5. Emission Level = Correction Factor + Reading Value.

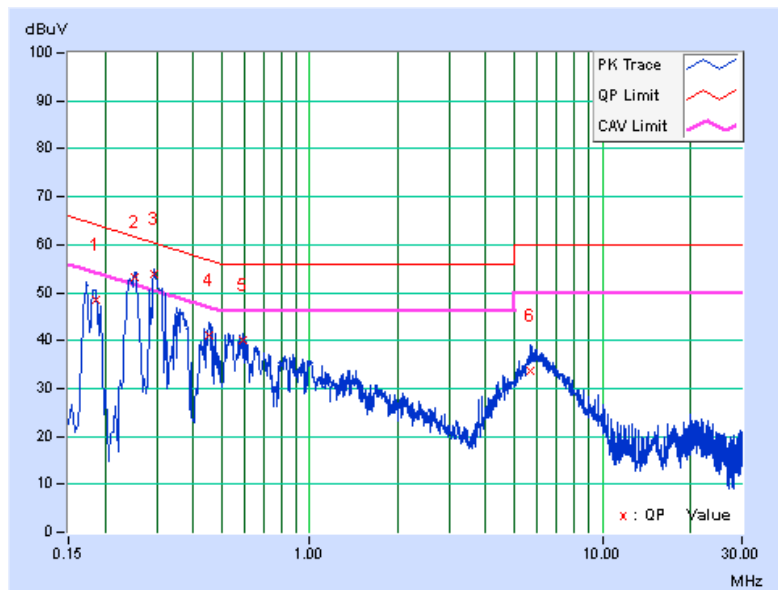

4.3 Transmit Power Measurement

4.3.1 Limits of Transmit Power Measurement

Frequency Band	Limit
5.150 ~ 5.250GHz	The lesser of 50mW (17dBm) or 4dBm + 10logB

*B is the 26 dB emission bandwidth in megahertz

Per KDB 662911 Method of conducted output power measurement on IEEE 802.11 devices,

Array Gain = 0 dB (i.e., no array gain) for $N_{ANT} \leq 4$;

Array Gain = 0 dB (i.e., no array gain) for channel widths ≥ 40 MHz for any N_{ANT} ;

Array Gain = $5 \log(N_{ANT}/N_{SS})$ dB or 3 dB, whichever is less for 20-MHz channel widths with $N_{ANT} \geq 5$.

For power measurements on all other devices: Array Gain = $10 \log(N_{ANT}/N_{SS})$ dB.

4.3.2 Test Setup

FOR POWER OUTPUT MEASUREMENT

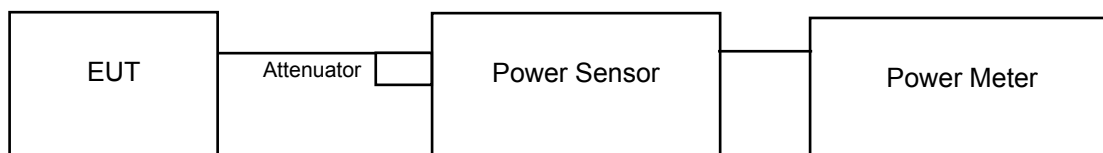

FOR 26dB BANDWIDTH

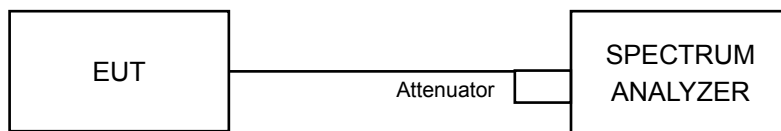

4.3.3 Test Instruments

Refer to section 4.1.2 to get information of above instrument.

4.3.4 Test Procedure

FOR AVERAGE POWER MEASUREMENT

For 802.11a, 802.11n (20MHz), 802.11n (40MHz), 802.11ac (20MHz), 802.11ac (40MHz)

Method PM is used to perform output power measurement, trigger and gating function of wide band power meter is enabled to measure max output power of TX on burst. Duty factor is not added to measured value.

For 802.11ac (80MHz)

- a. Set span to encompass the entire 26 dB EBW (or, alternatively, the entire 99% occupied bandwidth) of the signal.
- b. Set sweep trigger to "free run".
- c. Set RBW = 1 MHz.
- d. Set VBW \geq 3 MHz
- e. Number of points in sweep \geq 2 Span / RBW.
- f. Sweep time \leq (number of points in sweep) * T
- g. Using emission bandwidth to determine the frequency span for integration the channel bandwidth.
- h. Detector = RMS.
- i. Trace mode = max hold.
- j. Allow max hold to run for at least 60 seconds, or longer as needed to allow the trace to stabilize.

4.3.5 Deviation from Test Standard

No deviation.

4.3.6 EUT Operating Conditions

The software provided by client to enable the EUT under transmission condition continuously at lowest, middle and highest channel frequencies individually.

4.3.7 Test Result

Power Output:

802.11a

Chan.	Chan. Freq. (MHz)	Conducted Power (mW)	Conducted Power (dBm)	Power Limit (dBm)	Pass / Fail
36	5180	46.345	16.66	17	Pass
40	5200	44.978	16.53	17	Pass
48	5240	46.452	16.67	17	Pass

802.11n (20MHz)

Chan.	Chan. Freq. (MHz)	Maximum Conducted Power (dBm)		Total Power (mW)	Total Power (dBm)	Power Limit (dBm)	Pass / Fail
		Chain 0	Chain 1				
36	5180	13.84	13.23	45.248	16.56	17	Pass
40	5200	13.72	13.26	44.734	16.51	17	Pass
48	5240	13.59	13.62	45.870	16.62	17	Pass

802.11n (40MHz)

Chan.	Chan. Freq. (MHz)	Maximum Conducted Power (dBm)		Total Power (mW)	Total Power (dBm)	Power Limit (dBm)	Pass / Fail
		Chain 0	Chain 1				
38	5190	14.22	13.57	49.175	16.92	17	Pass
46	5230	14.11	13.57	48.514	16.86	17	Pass

802.11ac (20MHz)

Chan.	Chan. Freq. (MHz)	Maximum Conducted Power (dBm)		Total Power (mW)	Total Power (dBm)	Power Limit (dBm)	Pass / Fail
		Chain 0	Chain 1				
36	5180	14.08	13.36	47.263	16.75	17	Pass
40	5200	13.74	13.42	45.638	16.59	17	Pass
48	5240	13.37	13.73	45.332	16.56	17	Pass

802.11ac (40MHz)

Chan.	Chan. Freq. (MHz)	Maximum Conducted Power (dBm)		Total Power (mW)	Total Power (dBm)	Power Limit (dBm)	Pass / Fail
		Chain 0	Chain 1				
38	5190	14.27	13.59	49.586	16.95	17	Pass
46	5230	13.78	13.54	46.472	16.67	17	Pass

802.11ac (80MHz)

Chan.	Chan. Freq. (MHz)	Maximum Conducted Power (dBm)		Total Power (mW)	Total Power (dBm)	Power Limit (dBm)	Pass / Fail
		Chain 0	Chain 1				
42	5210	14.14	13.40	47.820	16.80	17	Pass

26dB Bandwidth:
802.11a

Channel	Channel Frequency (MHz)	26dBc Bandwidth (MHz)	Pass / Fail
36	5180	22.82	Pass
40	5200	23.01	Pass
48	5240	22.01	Pass

802.11n (20MHz)

Channel	Channel Frequency (MHz)	26dBc Bandwidth (MHz)		Pass / Fail
		Chain 0	Chain 1	
36	5180	23.69	23.15	Pass
40	5200	22.59	23.51	Pass
48	5240	23.17	22.61	Pass

802.11n (40MHz)

Channel	Channel Frequency (MHz)	26dBc Bandwidth (MHz)		Pass / Fail
		Chain 0	Chain 1	
38	5180	45.25	45.25	Pass
46	5200	46.50	46.07	Pass

802.11ac (20MHz)

Channel	Channel Frequency (MHz)	26dBc Bandwidth (MHz)		Pass / Fail
		Chain 0	Chain 1	
36	5180	23.05	23.43	Pass
40	5200	23.58	22.88	Pass
48	5240	23.40	22.65	Pass

802.11ac (40MHz)

Channel	Channel Frequency (MHz)	26dBc Bandwidth (MHz)		Pass / Fail
		Chain 0	Chain 1	
38	5180	46.50	45.02	Pass
46	5200	46.27	44.87	Pass

802.11ac (80MHz)

Channel	Channel Frequency (MHz)	26dBc Bandwidth (MHz)		Pass / Fail
		Chain 0	Chain 1	
42	5210	88.69	87.81	Pass

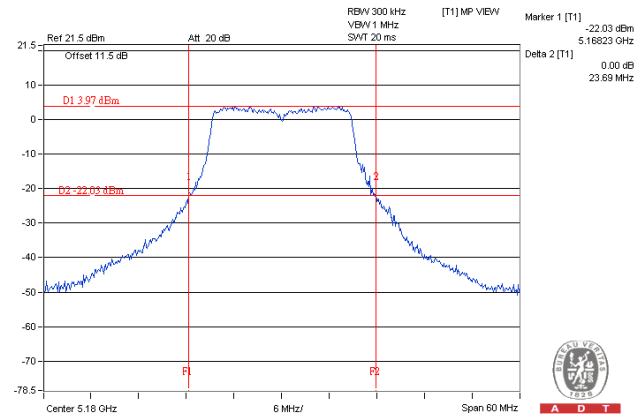
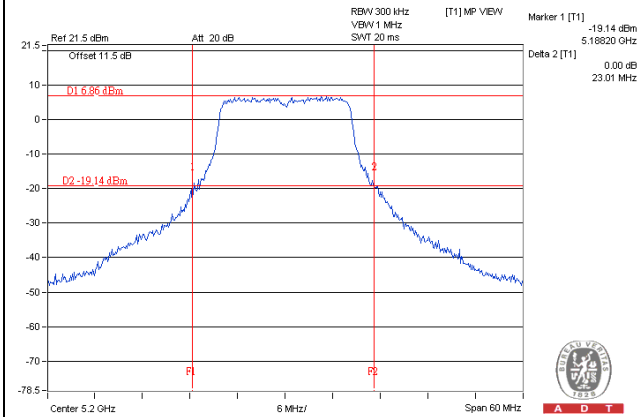
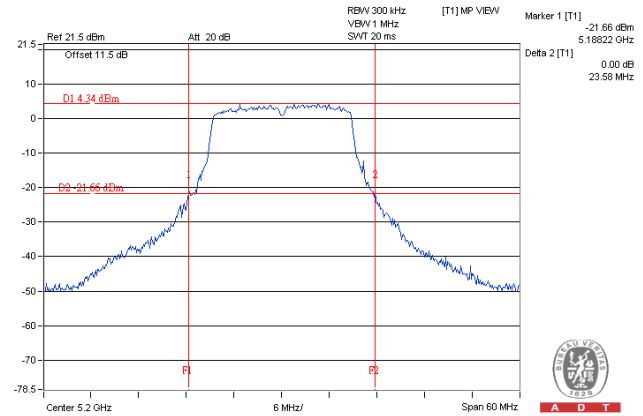
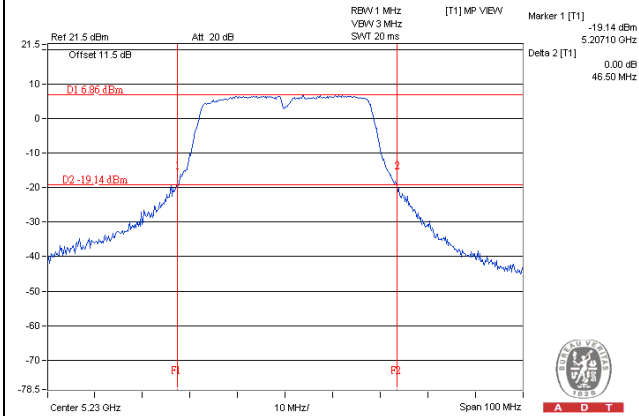
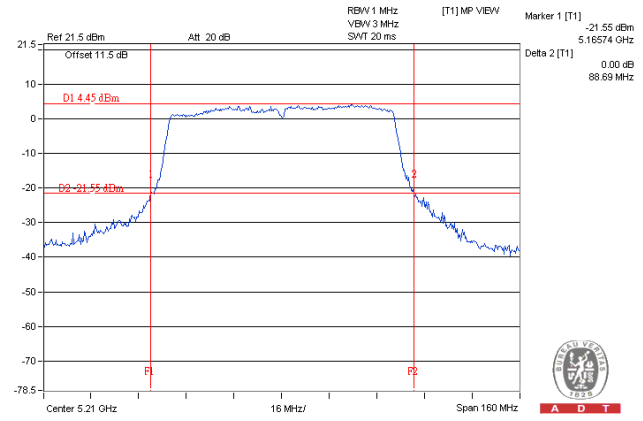
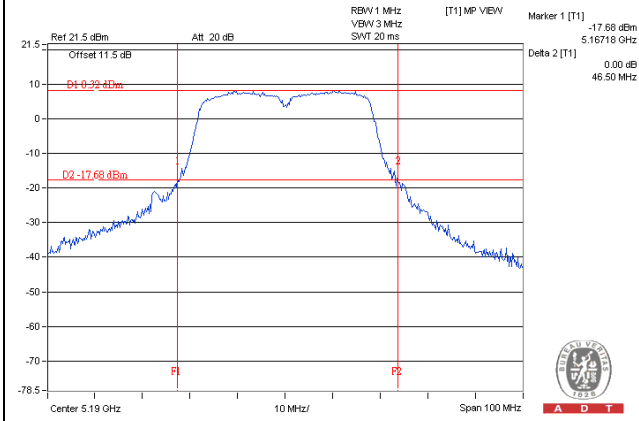
Spectrum Plot of Worst Value
802.11a
802.11n (20MHz)

802.11n (40MHz)
802.11ac (20MHz)

802.11ac (40MHz)
802.11ac (80MHz)

Occupied Bandwidth:
802.11a

Channel	Channel Frequency (MHz)	Occupied Bandwidth (MHz)
36	5180	16.80
40	5200	16.80
48	5240	16.80

802.11n (20MHz)

Channel	Channel Frequency (MHz)	Occupied Bandwidth (MHz)	
		Chain 0	Chain 1
36	5180	18.00	17.88
40	5200	17.76	17.88
48	5240	18.00	17.76

802.11n (40MHz)

Channel	Channel Frequency (MHz)	Occupied Bandwidth (MHz)	
		Chain 0	Chain 1
38	5180	36.72	36.72
46	5230	36.84	37.08

802.11ac (20MHz)

Channel	Channel Frequency (MHz)	Occupied Bandwidth (MHz)	
		Chain 0	Chain 1
36	5180	17.76	17.88
40	5200	17.76	18.00
48	5240	17.88	17.76

802.11ac (40MHz)

Channel	Channel Frequency (MHz)	Occupied Bandwidth (MHz)	
		Chain 0	Chain 1
38	5180	36.72	36.84
46	5230	36.84	36.84

802.11ac (80MHz)

Channel	Channel Frequency (MHz)	Occupied Bandwidth (MHz)	
		Chain 0	Chain 1
42	5210	75.84	76.08

Spectrum Plot of Worst Value

802.11a

802.11n (20MHz)

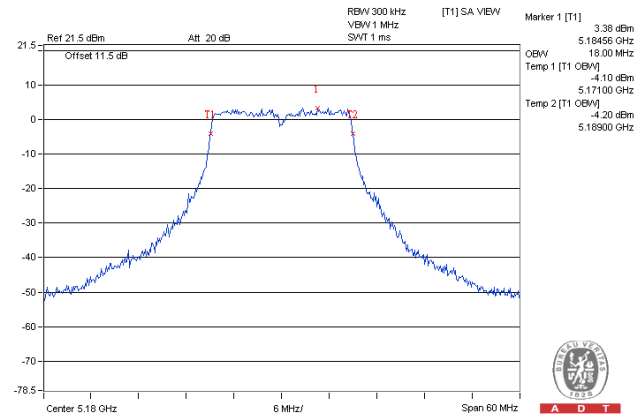
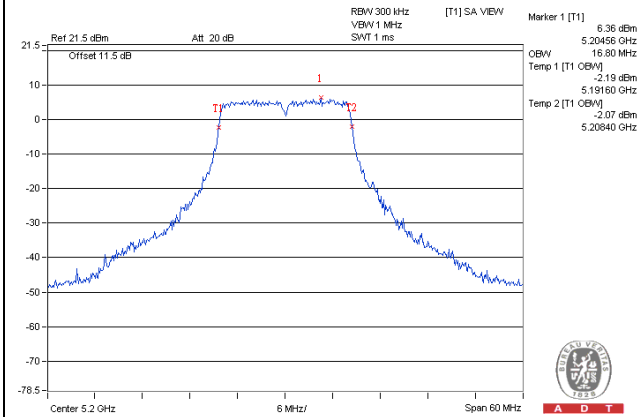

802.11n (40MHz)

802.11ac (20MHz)

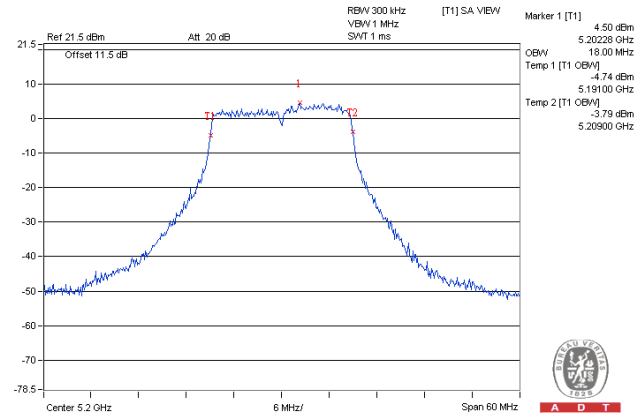
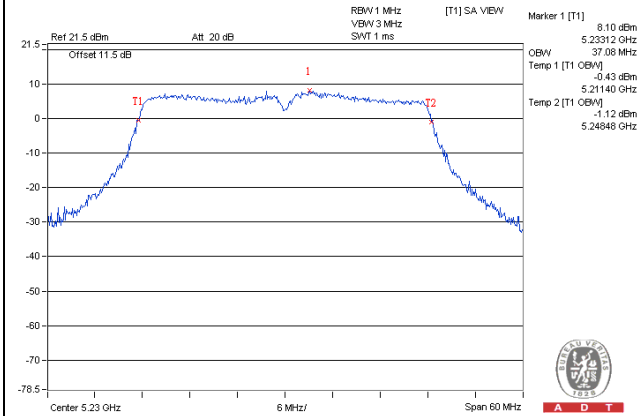

802.11ac (40MHz)

802.11ac (80MHz)

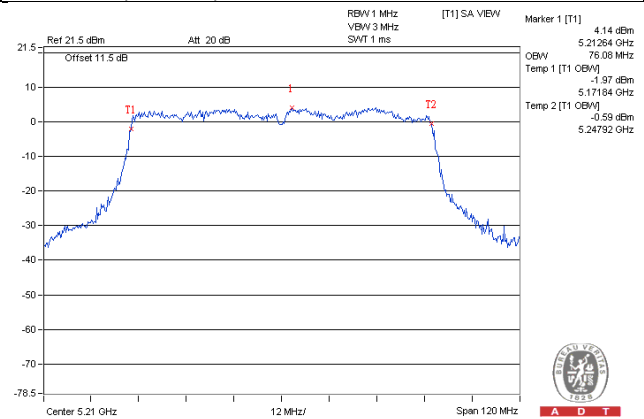
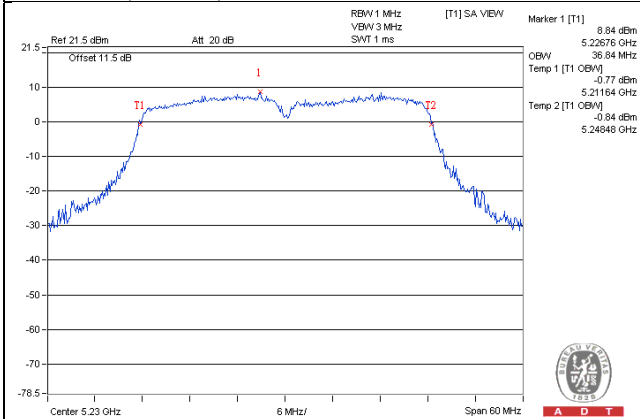

4.4 Peak Power Spectral Density Measurement

4.4.1 Limits of Peak Power Spectral Density Measurement

Frequency Band	Limit
5.150 ~ 5.250GHz	4dBm

4.4.2 Test Setup

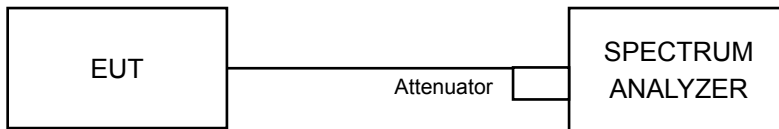

4.4.3 Test Instruments

Refer to section 4.1.2 to get information of above instrument.

4.4.4 Test Procedures

Using method SA-1 (Duty cycle >98%)

- Set span to encompass the entire emission bandwidth (EBW) of the signal.
- Set RBW = 1 MHz, Set VBW \geq 3 MHz, Detector = RMS
- Sweep time = auto, trigger set to "free run".
- Trace average at least 100 traces in power averaging mode.
- Record the max value

Using method SA-2 (Duty cycle <98%)

- Set span to encompass the entire emission bandwidth (EBW) of the signal.
- Set RBW = 1 MHz, Set VBW \geq 3 MHz, Detector = RMS
- Sweep time = auto, trigger set to "free run".
- Trace average at least 100 traces in power averaging mode.
- Record the max value and add $10 \log (1/\text{duty cycle})$

4.4.5 Deviation from Test Standard

No deviation.

4.4.6 EUT Operating Conditions

Same as Item 4.3.6.

4.4.7 Test Results

802.11a

Chan.	Chan. Freq. (MHz)	PSD W/O Duty Factor (dBm)	Duty Factor	PSD With Duty Factor (dBm)	Max. Limit (dBm)	Pass/Fail
36	5180	2.63	0.12	2.75	4.00	Pass
40	5200	2.31	0.12	2.43	4.00	Pass
48	5240	2.45	0.12	2.57	4.00	Pass

Note:

1. Method 1 of power density measurement of KDB 662911 is using for calculating total power density. Total power density is summing entire spectra across corresponding frequency bins on the various outputs by computer.
2. Refer to section 3.3 for duty cycle spectrum plot.

802.11n (20MHz)

Chan.	Chan. Freq. (MHz)	PSD (dBm)		Total PSD W/O Duty Factor (dBm)	Duty Factor	Total PSD With Duty Factor (dBm)	Max. Limit (dBm)	Pass/Fail
		Chain 0	Chain 1					
36	5180	-0.47	0.56	3.09	0.14	3.23	3.85	Pass
40	5200	-0.51	0.39	2.98	0.14	3.12	3.85	Pass
48	5240	-0.90	0.41	2.82	0.14	2.96	3.85	Pass

Note:

1. Method 1 of power density measurement of KDB 662911 is using for calculating total power density. Total power density is summing entire spectra across corresponding frequency bins on the various outputs by computer.
2. Directional gain = $10 \log[(10^{G1/20} + 10^{G2/20} + \dots + 10^{GN/20})^2 / N_{ANT}] = 6.15 \text{dBi} > 6 \text{dBi}$, so the power density limit shall be reduced to $4 - (6.15 - 6) = 3.85 \text{dBm}$.
3. Refer to section 3.3 for duty cycle spectrum plot.

802.11n (40MHz)

Chan.	Chan. Freq. (MHz)	PSD (dBm)		Total PSD W/O Duty Factor (dBm)	Duty Factor	Total PSD With Duty Factor (dBm)	Max. Limit (dBm)	Pass/Fail
		Chain 0	Chain 1					
38	5190	-2.75	-2.11	0.60	0.27	0.87	3.85	Pass
46	5230	-3.58	-2.42	0.05	0.27	0.32	3.85	Pass

Note:

1. Method 1 of power density measurement of KDB 662911 is using for calculating total power density. Total power density is summing entire spectra across corresponding frequency bins on the various outputs by computer.
2. Directional gain = $10 \log[(10^{G1/20} + 10^{G2/20} + \dots + 10^{GN/20})^2 / N_{ANT}] = 6.15 \text{dBi} > 6 \text{dBi}$, so the power density limit shall be reduced to $4 - (6.15 - 6) = 3.85 \text{dBm}$.
3. Refer to section 3.3 for duty cycle spectrum plot.

802.11ac (20MHz)

Chan.	Chan. Freq. (MHz)	PSD (dBm)		Total PSD W/O Duty Factor (dBm)	Duty Factor	Total PSD With Duty Factor (dBm)	Max. Limit (dBm)	Pass/Fail
		Chain 0	Chain 1					
36	5180	0.10	0.66	3.44	0.12	3.52	3.85	Pass
40	5200	-0.20	0.58	3.22	0.12	3.34	3.85	Pass
48	5240	-0.51	0.60	3.09	0.12	3.21	3.85	Pass

Note:

- Method 1 of power density measurement of KDB 662911 is using for calculating total power density. Total power density is summing entire spectra across corresponding frequency bins on the various outputs by computer.
- Directional gain = $10 \log[(10^{G1/20} + 10^{G2/20} + \dots + 10^{GN/20})^2 / N_{ANT}] = 6.15\text{dBi} > 6\text{dBi}$, so the power density limit shall be reduced to $4 - (6.15 - 6) = 3.85\text{dBm}$.
- Refer to section 3.3 for duty cycle spectrum plot.

802.11ac (40MHz)

Chan.	Chan. Freq. (MHz)	PSD (dBm)		Total PSD W/O Duty Factor (dBm)	Duty Factor	Total PSD With Duty Factor (dBm)	Max. Limit (dBm)	Pass/Fail
		Chain 0	Chain 1					
38	5190	-2.39	-2.20	0.71	0.30	1.01	3.85	Pass
46	5230	-3.31	-2.38	0.19	0.30	0.49	3.85	Pass

Note:

- Method 1 of power density measurement of KDB 662911 is using for calculating total power density. Total power density is summing entire spectra across corresponding frequency bins on the various outputs by computer.
- Directional gain = $10 \log[(10^{G1/20} + 10^{G2/20} + \dots + 10^{GN/20})^2 / N_{ANT}] = 6.15\text{dBi} > 6\text{dBi}$, so the power density limit shall be reduced to $4 - (6.15 - 6) = 3.85\text{dBm}$.
- Refer to section 3.3 for duty cycle spectrum plot.

802.11ac (80MHz)

Chan.	Chan. Freq. (MHz)	PSD (dBm)		Total PSD W/O Duty Factor (dBm)	Duty Factor	Total PSD With Duty Factor (dBm)	Max. Limit (dBm)	Pass/Fail
		Chain 0	Chain 1					
42	5210	-6.54	-5.89	-3.19	0.50	-2.69	3.85	Pass

Note:

- Method 1 of power density measurement of KDB 662911 is using for calculating total power density. Total power density is summing entire spectra across corresponding frequency bins on the various outputs by computer.
- Directional gain = $10 \log[(10^{G1/20} + 10^{G2/20} + \dots + 10^{GN/20})^2 / N_{ANT}] = 6.15\text{dBi} > 6\text{dBi}$, so the power density limit shall be reduced to $4 - (6.15 - 6) = 3.85\text{dBm}$.
- Refer to section 3.3 for duty cycle spectrum plot.

Spectrum Plot of Worst Value

802.11a

802.11n (20MHz)

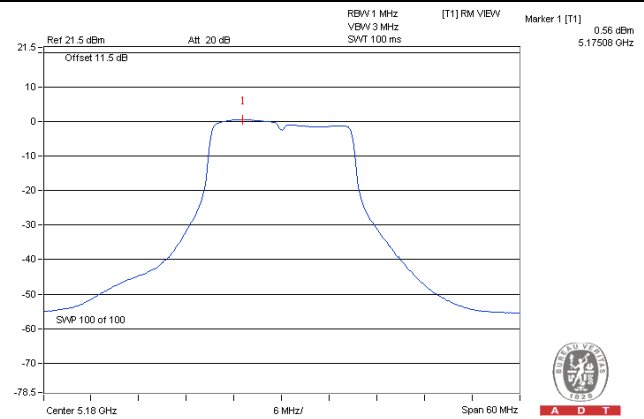
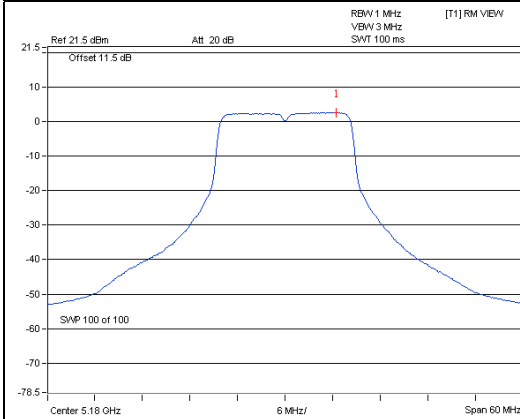

802.11n (40MHz)

802.11ac (20MHz)

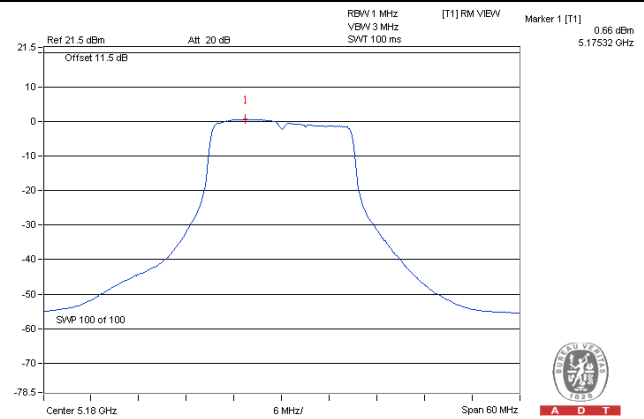
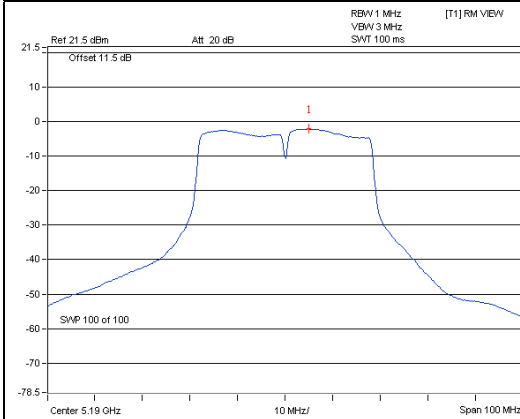

802.11ac (40MHz)

802.11ac (80MHz)

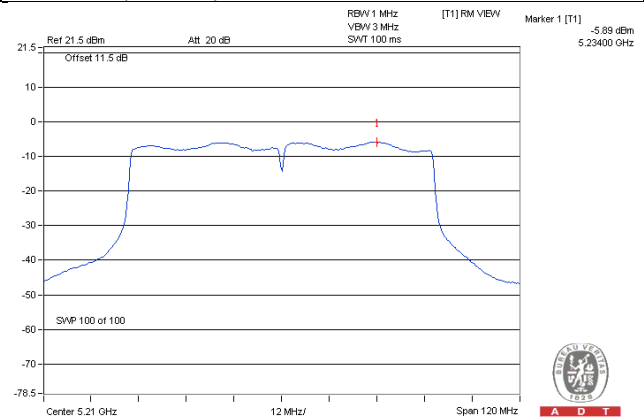
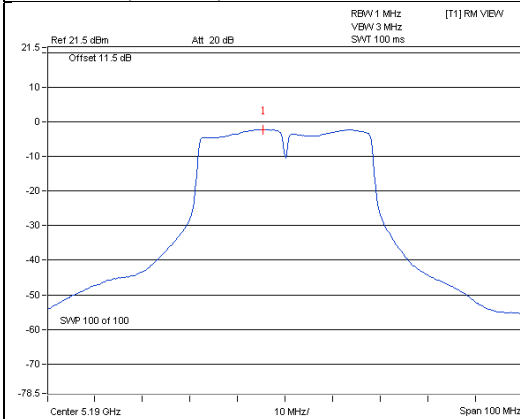

4.5 Peak Power Excursion Measurement

4.5.1 Limits of Peak Power Excursion Measurement

Shall not exceed 13 dB.

4.5.2 Test Setup

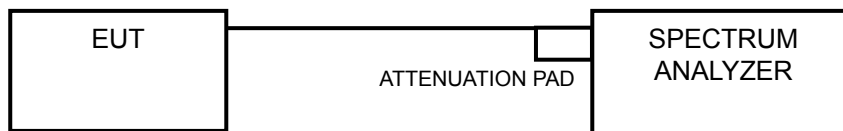

4.5.3 Test Instruments

Refer to section 4.1.3 to get information of above instrument.

4.5.4 Test Procedure

- Set RBW = 1 MHz, VBW \geq 3 MHz, Detector = peak.
- Trace mode = max-hold. Allow the sweeps to continue until the trace stabilizes.
- Use the peak search function to find the peak of the spectrum.
- Measure the PPSD.
- Compute the ratio of the maximum of the peak-max-hold spectrum to the PPSD.
- Find the worst channel and modulation mode as above test procedure, and follow KDB 789033 D01 General UNII Test Procedure Old Rules v01r04 and repeat step 1 to 5 for final testing of each modulation mode on a single channel (all modulation types) in a single operating band to compliance with the peak excursion requirement.

4.5.5 Deviation From Test Standard

No deviation

4.5.6 EUT Operating Condition

Same as 4.2.6

4.5.7 Test Results

Modulation Mode	Modulation Type	Chan. Freq. (MHz)	Peak Value (dBm)	PPSD without Duty Factor (dBm)	PPSD with Duty Factor (dBm)	Peak Excursion (dB)	Limit (dB)	Pass / Fail
802.11a	BPSK	5240	11.42	2.45	2.57	8.85	13	Pass
	QPSK		11.97	2.06	2.29	9.68	13	Pass
	16QAM		11.88	1.66	2.14	9.74	13	Pass
	64QAM		12.55	1.34	2.33	10.22	13	Pass
802.11n (20MHz)	BPSK	5240	8.11	-0.90	-0.76	8.87	13	Pass
	QPSK		8.94	-0.93	-0.68	9.62	13	Pass
	16QAM		9.62	-0.96	-0.47	10.09	13	Pass
	64QAM		9.19	-1.37	-0.48	9.67	13	Pass
802.11n (40MHz)	BPSK	5230	5.63	-3.58	-3.31	8.94	13	Pass
	QPSK		6.25	-3.67	-3.11	9.36	13	Pass
	16QAM		6.93	-3.82	-2.97	9.90	13	Pass
	64QAM		7.97	-4.11	-2.63	10.60	13	Pass
802.11ac (20MHz)	BPSK	5240	8.69	-0.51	-0.39	9.08	13	Pass
	QPSK		9.05	-0.87	-0.61	9.66	13	Pass
	16QAM		9.73	-0.94	-0.45	10.18	13	Pass
	64QAM		9.16	-1.40	-0.54	9.70	13	Pass
	256QAM		9.59	-1.50	-0.26	9.85	13	Pass
802.11ac (40MHz)	BPSK	5230	6.37	-3.31	-3.01	9.38	13	Pass
	QPSK		6.56	-3.60	-3.09	9.65	13	Pass
	16QAM		7.09	-3.88	-2.96	10.05	13	Pass
	64QAM		7.60	-4.10	-2.62	10.22	13	Pass
	256QAM		7.16	-4.24	-2.30	9.46	13	Pass
802.11ac (80MHz)	BPSK	5210	3.52	-6.54	-6.04	9.56	13	Pass
	QPSK		4.17	-6.81	-5.73	9.90	13	Pass
	16QAM		4.78	-6.91	-5.41	10.19	13	Pass
	64QAM		4.29	-7.05	-4.58	8.87	13	Pass
	256QAM		4.60	-7.25	-4.73	9.33	13	Pass

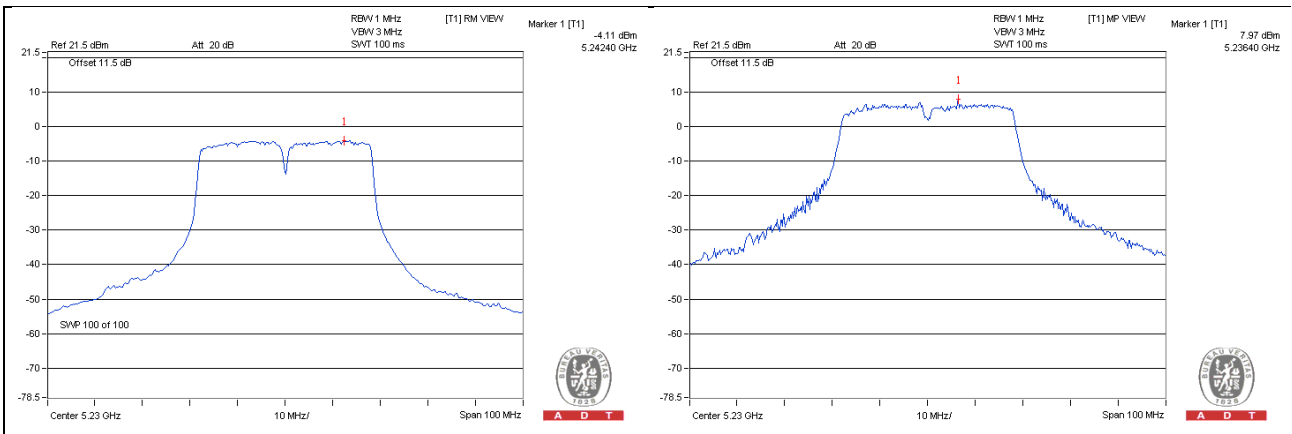

4.6 Frequency Stability

4.6.1 Limits of Frequency Stability Measurement

The frequency of the carrier signal shall be maintained within band of operation

4.6.2 Test Setup

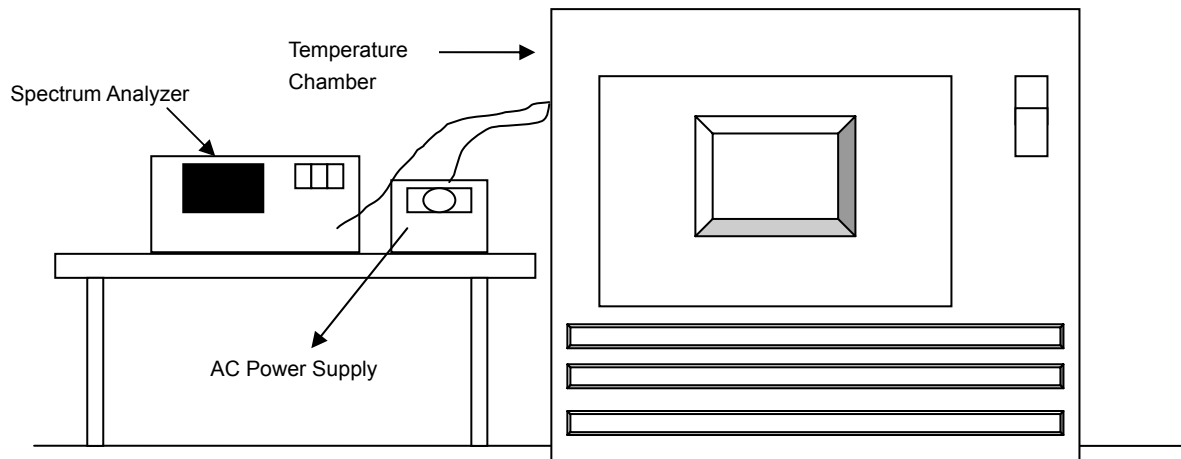

4.6.3 Test Instruments

Refer to section 4.1.2 to get information of above instrument.

4.6.4 Test Procedure

- The EUT was placed inside the environmental test chamber and powered by nominal AC voltage.
- Turn the EUT on and couple its output to a spectrum analyzer.
- Turn the EUT off and set the chamber to the highest temperature specified.
- Allow sufficient time (approximately 30 min) for the temperature of the chamber to stabilize, turn the EUT on and measure the operating frequency after 2, 5, and 10 minutes.
- Repeat step 2 and 3 with the temperature chamber set to the lowest temperature.
- The test chamber was allowed to stabilize at +20 degree C for a minimum of 30 minutes. The supply voltage was then adjusted on the EUT from 85% to 115% and the frequency record.

4.6.5 Deviation from Test Standard

No deviation.

4.6.6 EUT Operating Condition

Set the EUT transmit at un-modulation mode to test frequency stability.

4.6.7 Test Results

Frequency Stability Versus Temp.									
Operating Frequency: 5180MHz									
Temp. (°C)	Power Supply (Vac)	0 Minute		2 Minute		5 Minute		10 Minute	
		Measured Frequency (MHz)	Frequency Drift (%)	Measured Frequency (MHz)	Frequency Drift (%)	Measured Frequency (MHz)	Frequency Drift (%)	Measured Frequency (MHz)	Frequency Drift (%)
50	120	5179.9923	-0.00015	5179.9927	-0.00014	5179.9893	-0.00021	5179.9886	-0.00022
40	120	5180.007	0.00014	5180.0113	0.00022	5180.009	0.00017	5180.0096	0.00019
30	120	5179.9798	-0.00039	5179.9788	-0.00041	5179.9768	-0.00045	5179.978	-0.00042
20	120	5180.0217	0.00042	5180.0207	0.00040	5180.0248	0.00048	5180.022	0.00042
10	120	5179.9754	-0.00047	5179.976	-0.00046	5179.9749	-0.00048	5179.9742	-0.00050
0	120	5180.0067	0.00013	5180.0088	0.00017	5180.0047	0.00009	5180.0047	0.00009
-10	120	5179.9941	-0.00011	5179.9948	-0.00010	5179.9951	-0.00009	5179.9934	-0.00013
-20	120	5179.9974	-0.00005	5179.9977	-0.00004	5179.9962	-0.00007	5179.9999	0.00000
-30	120	5180.0178	0.00034	5180.0151	0.00029	5180.0133	0.00026	5180.0153	0.00030

Frequency Stability Versus Temp.									
Operating Frequency: 5180MHz									
Temp. (°C)	Power Supply (Vac)	0 Minute		2 Minute		5 Minute		10 Minute	
		Measured Frequency (MHz)	Frequency Drift (%)	Measured Frequency (MHz)	Frequency Drift (%)	Measured Frequency (MHz)	Frequency Drift (%)	Measured Frequency (MHz)	Frequency Drift (%)
20	138	5180.0214	0.00041	5180.0197	0.00038	5180.0245	0.00047	5180.0214	0.00041
	120	5180.0217	0.00042	5180.0207	0.00040	5180.0248	0.00048	5180.022	0.00042
	102	5180.0211	0.00041	5180.0215	0.00042	5180.0242	0.00047	5180.0213	0.00041

5 Pictures of Test Arrangements

Please refer to the attached file (Test Setup Photo).

Appendix – Information on the Testing Laboratories

We, Bureau Veritas Consumer Products Services (H.K.) Ltd., Taoyuan Branch, were founded in 1988 to provide our best service in EMC, Radio, Telecom and Safety consultation. Our laboratories are accredited and approved according to ISO/IEC 17025.

If you have any comments, please feel free to contact us at the following:

Linko EMC/RF Lab

Tel: 886-2-26052180

Fax: 886-2-26051924

Hsin Chu EMC/RF Lab/Telecom Lab

Tel: 886-3-5935343

Fax: 886-3-5935342

Hwa Ya EMC/RF/Safety

Tel: 886-3-3183232

Fax: 886-3-3270892

Email: service.adt@tw.bureauveritas.com

Web Site: www.bureauveritas-adt.com

The address and road map of all our labs can be found in our web site also.

--- END ---