



849 NW STATE ROAD 45
NEWBERRY, FL 32669 USA
PH: 888.472.2424 OR 352.472.5500
FAX: 352.472.2030
EMAIL: INFO@TIMCOENGR.COM
[HTTP://WWW.TIMCOENGR.COM](http://WWW.TIMCOENGR.COM)

COMPLIANCE TEST REPORT PER FCC PART 90

APPLICANT	TELTRONIC S.A.U
	Poligono Malpica Calie F Parceia 12 ZARAGOZA 50057 Spain
FCC ID	WT7PTRUNK25RF450
PRODUCT DESCRIPTION	450-470 MHZ 2-WAY TRANSCEIVER
DATE SAMPLE RECEIVED	10/13/2008
DATE TESTED	10/20/2008
TESTED BY	Nam Nguyen
APPROVED BY	Mario de Aranzeta
TIMCO REPORT NO.	2138AUT8TestReport.pdf
TEST RESULTS	<input checked="" type="checkbox"/> PASS <input type="checkbox"/> FAIL

**THE ATTACHED REPORT SHALL NOT BE REPRODUCED EXCEPT IN FULL
WITHOUT THE WRITTEN APPROVAL OF TIMCO ENGINEERING, INC.**



Certificate # 0955-01

TABLE OF CONTENTS

ATTESTATION	3
DUT SPECIFICATION.....	4
TEST ENVIRONMENT AND TEST SETUP	5
TEST EQUIPMENT.....	6
TEST PROCEDURE.....	7
TEST RESULT	10
RF Power Output.....	10
Occupied Bandwidth	12
Modulation Characteristics	13
Voice Modulated Communication Equipment	13
Other Modulation Characteristics.....	14
Spurious Emissions At Antenna Terminals (Conducted)	17
Field Strength Of Spurious Emissions	18
Frequency Stability	20
Transient Frequency Behavior	21

ATTESTATION

This equipment has been tested in accordance with the standards identified in this test report. To the best of my knowledge and belief, these tests were performed using the measurement procedures described in this report.

All instrumentation and accessories used to test products for compliance to the indicated standards are calibrated regularly in accordance with ISO 17025 requirements.



Testing Certificate # 0955-01

I attest that the necessary measurements were made, under my supervision, at:

Timco Engineering Inc.
849 NW State Road 45
Newberry, Fl 32669

Authorized Signatory Name:

Mario de Aranzeta C.E.T.
Compliance Engineer/ Lab. Supervisor

Date: 10/30/2008

DUT SPECIFICATION

DUT Description	450-470 MHZ 2-WAY TRANSCEIVER
FCC ID	WT7PTRUNK25RF450
IC Certification	To Be Determined
Model Number	To Be Determined
Serial Number	N/A
Operating Frequency	450 – 470 MHz
Test Frequencies	450 MHz 460 MHz 470 MHz
Type of Emission	F21D, F1W, F3E
Modulation	FM, Digital
DUT Power Source	<input type="checkbox"/> 110–120Vac/50– 60Hz
	<input checked="" type="checkbox"/> DC Power 26.4V
	<input type="checkbox"/> Battery Operated Exclusively
Test Item	<input type="checkbox"/> Prototype
	<input checked="" type="checkbox"/> Pre-Production
	<input type="checkbox"/> Production
Type of Equipment	<input checked="" type="checkbox"/> Fixed
	<input type="checkbox"/> Mobile
	<input type="checkbox"/> Portable

TEST ENVIRONMENT AND TEST SETUP

Test Facility	All tests were conducted by Timco Engineering Inc. located at 849 NW State Road 45, Newberry, FL 32669 USA
Laboratory Test Condition	Temperature: 26°C Relative humidity: 50%.
Deviation from the standards	No deviation
Modification to the DUT	No modification was made.
Test Exercise (software etc.)	The DUT was placed in continuous transmitting mode of operation.
System Setup	Stand alone device.

TEST EQUIPMENT

Device	Manufacturer	Model	Serial Number	Cal/Char Date	Due Date
Analyzer Tan Tower Spectrum Analyzer	HP	8566B Opt 462	3138A07786 3144A20661	CAL 12/7/07	12/7/09
Analyzer Tan Tower RF Preselector	HP	85685A	3221A01400	CAL 12/7/07	12/7/09
Analyzer Tan Tower Quasi-Peak Adapter	HP	85650A	3303A01690	CAL 12/8/07	12/8/09
Analyzer Tan Tower Preamplifier	HP	8449B-H02	3008A00372	CAL 12/8/07	12/8/09
Antenna: Biconnical	Electro-Metrics	BIA-25	1171	CAL 4/29/07	4/29/09
Antenna: Double-Ridged Horn	Electro-Metrics	RGA-180	2319	CAL 12/29/06	12/29/08
Termaline Wattmeter	Bird Electronic Corporation	611	16405	CAL 7/16/07	7/16/09

TEST PROCEDURE

Power Line Conducted Interference

The procedure used was ANSI 63.4-2003 using a 50uH LISN. Both lines were observed with the DUT transmitting. The bandwidth of the spectrum analyzer was 10 kHz with an appropriate sweep speed.

RF Power Output

The RF power output was measured at the antenna feed point using a peak power meter. A 50-ohm, resistive wattmeter was connected to the RF output connector. With a nominal battery voltage, and the transmitter properly adjusted the RF output measures:

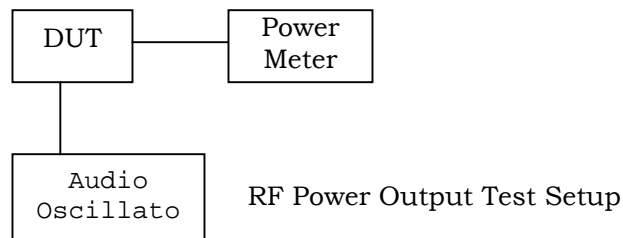

Spurious Emissions At Antenna Terminals (Conducted)

The carrier was modulated 100%. The spectrum was scanned from 0.4 to at least the 10th harmonic of the fundamental. Above 1 GHz the resolution bandwidth was 1 MHz and the VBW = 3 MHz and the span to 50 MHz. The measurements were made in accordance with standard ANSI/TIA-603-C: 2004

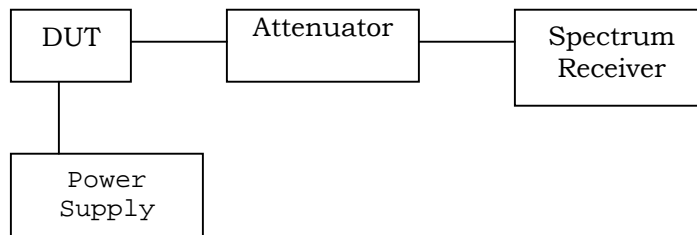

Radiation Interference

The test procedure used was ANSI/TIA-603-C: 2004 and ANSI C63.4-2003 using an Agilent spectrum receiver with pre-selector. The bandwidth (RBW) of the spectrum receiver was 100 kHz up to 1 GHz and 1 MHz above 1 GHz with an appropriate sweep speed. The VBW above 1 GHz was 3 MHz. The analyzer was calibrated in dB above a microvolt at the output of the antenna.

Modulation Characteristic

Audio frequency response

The audio frequency response was measured in accordance with ANSI/TIA 603-C: 2004.

Audio Low Pass Filter

The audio low pass filter for voice-modulated equipment was measured in accordance with ANSI/TIA 603-C: 2004.

Audio Input versus modulation

The audio input level needed for a particular percentage of modulation was measured in accordance with ANSI/TIA 603-C: 2004. Curves are provided for audio input frequencies of 300, 1000, and 3000 Hz.

Frequency Stability

The frequency stability was measured per ANSI/TIA 603-C: 2004.

Field Strength of Spurious Emissions

The spectrum was scanned from 30 MHz to at least the tenth harmonic of the fundamental. This test was conducted per ANSI/TIA 603-C: 2004 using the substitution method.

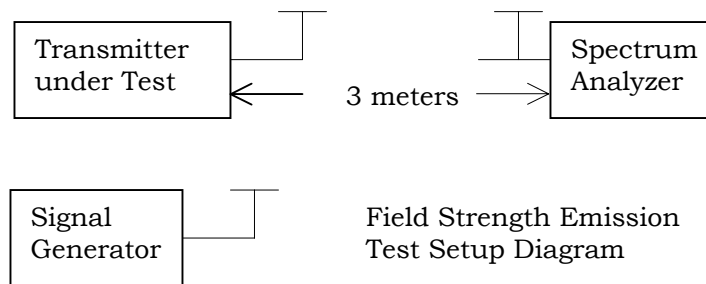

Transient Frequency Behavior

The test procedure was ANSI/TIA 603-C: 2004 Para 2.2.19.

- Using the variable attenuator. The transmitter level was set to 40 dB below the test receivers maximum input level,
- Then the transmitter was turned off.
- With the transmitter off the signal generator was set 20dB below the level of the transmitter in the above step, this level will be maintained with the signal generator through-out the test.
- Reduce the attenuation between the transmitter and the RF detector by 30 dB.
- With the levels set as above the transient frequency behavior was observed & recorded.

Transient Frequency Response Test setup

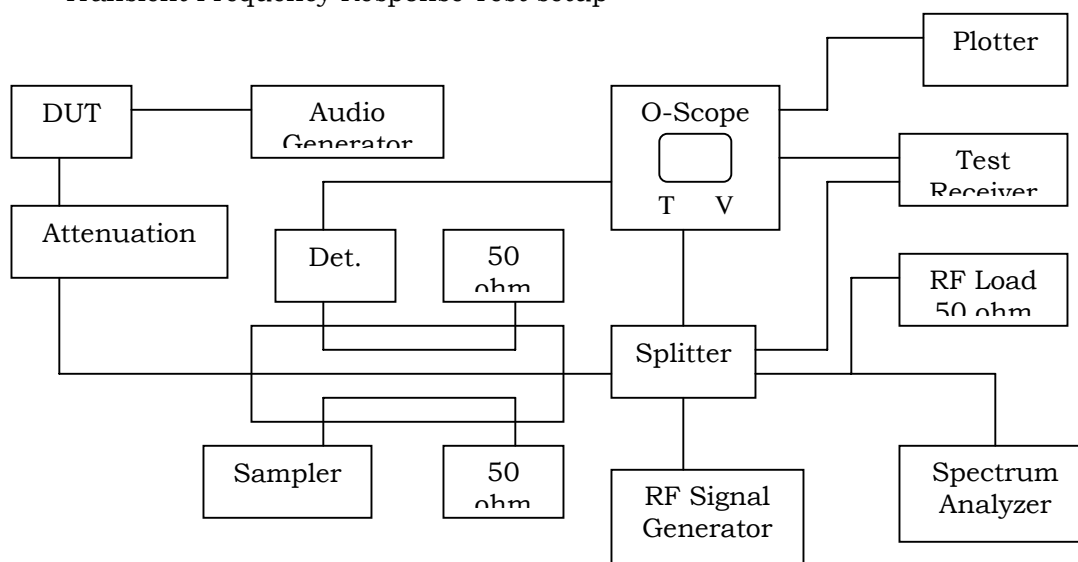

TEST RESULT

RF Power Output

Rule Part No.: FCC Part 2.1046(a), IC RSS-119 4.1 and 5.4, RSS-GEN 4.8

Requirements: Pt 2.1046

Test Data:

Highest Output Power: 100.0 Watts
Lowest Output Power: 100.0 Watts

Part 2.1033 (C)(8) DC Input into the final amplifier

POWER SETTING INPUT POWER: $(26.4 \text{ V})(20.0 \text{ A}) = 528.0 \text{ Watts}$

Bandwidth Limitations:

Rule Part No.: Part 2.1033(c) (4), Part 90.209, IC RSS-119 5.5, Part 90.207

Test Data:

NOTES:

TELTRONIC, S.A.U - Product description: RF Unit Base Station Radio/Repeater
 20dB OCCUPIED BANDWIDTH PLOT - MARKER DELTA = 9.04 kHz

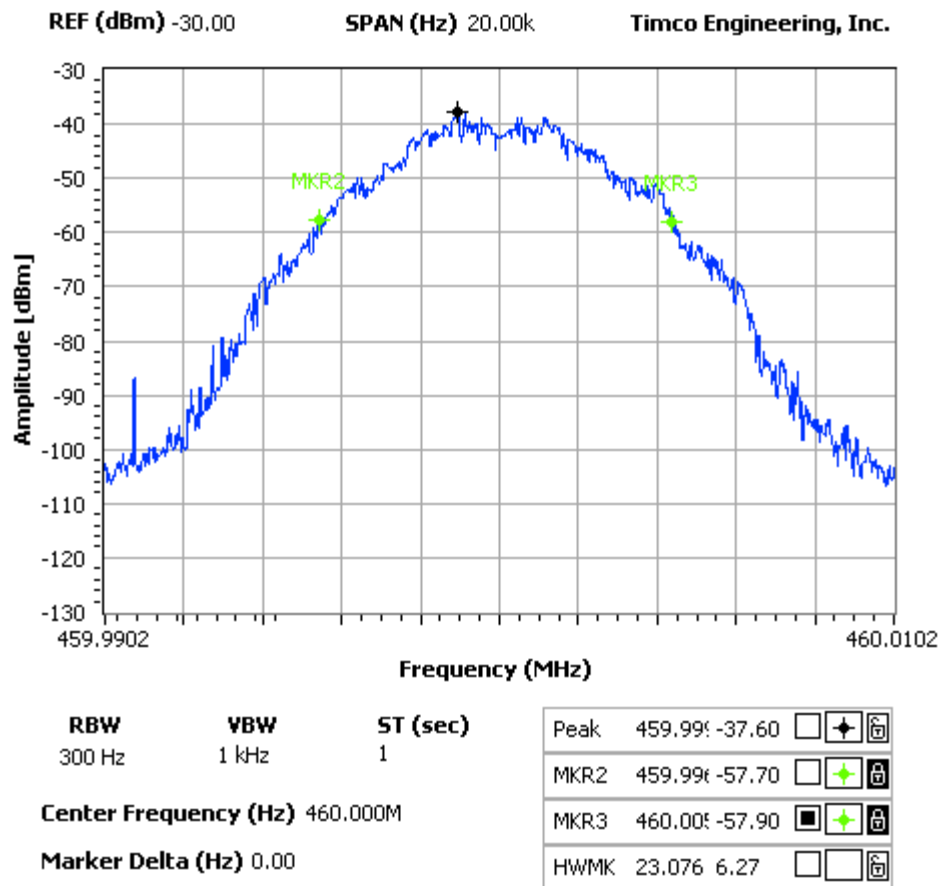

Occupied Bandwidth

Rule Part No.: FCC Part 2.1049(c), RSS-GEN 4.6, ANSI/TIA-603-C: 2004 para 2.2.11.

Requirements:

FCC Part 90.210(b) RSS-119 4.2 25kHz Channel Spacing

Data in the plots show that on any frequency removed from the assigned frequency by more than 50%, but not more than 100%: At least 25dB. On any frequency removed from the assigned frequency by more than 100%, but not more than 250%: At least 35 dB. On any frequency removed from the assigned frequency by more than 250%, of the authorized bandwidth: At least $43 + 10\log(P)$ dB.

Part 90.210(c) 12.5kHz Channel Spacing Not Equipped with a Low Pass Filter

For transmitters that are not equipped with an audio low pass filter pursuant to S90.211 (b), the power of any emission must be attenuated below the un-modulated carrier output power as follows; (1) On any frequency removed from the center of the authorized bandwidth by a displacement frequency (f_d in kHz) of more than 5 kHz but not more than 10 kHz: At least $83 \log(f_d/5)$ dB; (2) ON any frequency removed from the center of the authorized bandwidth by a displacement frequency (f_d in kHz) of more than 10 kHz, but not more than 250% of the authorized bandwidth: At least $29 \log(f_d/11)$ dB or 50 dB, whichever is the lesser attenuation; (3) On any frequency removed from the center of the authorized bandwidth by more than 250% of the authorized bandwidth: At least $43+10 \log(P_0)$ dB.

Part 90.210(d) Emission Mask D - 12.5 kHz channel BW equipment.

For transmitters designed to operate with a 12.5 kHz channel bandwidth, any emission must be attenuated below the power (P) of the highest emission contained within the authorized bandwidth as follows:

- (1) On any frequency from the center of the authorized bandwidth f_0 to 5.625 kHz removed from f_0 : Zero dB.
- (2) On any frequency from the center of the authorized bandwidth by a displacement frequency (f_d in kHz) of more than 5.625 kHz but no more than 12.5 kHz: At least $7.27(f_d - 2.88 \text{ kHz})$ dB.
- (3) On any frequency removed from the center of the authorized bandwidth by a displacement frequency (f_d in kHz) of more than 12.5 kHz: At least $50 + 10\log(P)$ dB or 70 dB, whichever is the lesser attenuation.

Part 90.210(e) Emission Mask E – 6.25 kHz channel BW equipment.

For transmitters designed to operate with a 6.25 kHz bandwidth, any emission must be attenuated below the power (P) of the highest emission contained within the authorized bandwidth as follows:

- (1) On any frequency from the center of the authorized bandwidth f_0 to 3.0 kHz removed from f_0 : Zero dB.
- (2) On any frequency from the center of the authorized bandwidth by a displacement frequency (f_d in kHz) of more than 3.0 kHz but no more than 4.6 kHz: At least $30 + 16.67(f_d - 3.0 \text{ kHz})$ or $55 + 10 \log(P)$ or 65, whichever is the lesser attenuation.
- (3) On any frequency removed from the center of the authorized bandwidth by more than 4.6kHz: At least $55 + 10\log(P)$ dB or 65 dB, whichever is the lesser attenuation.

Modulation Characteristics

Rule Part No.: Part 2.1047(a)(b)

Test Requirements:

Method of Measurement:

Audio frequency response

The audio frequency response was measured in accordance with ANSI/TIA 603-C:2004. A curve or equivalent data showing the frequency response of the audio modulating circuit over a range of 100 – 5000Hz shall be submitted. The audio frequency response curve is shown below.

Voice Modulated Communication Equipment

Part 2.1047(a): For equipment required to have an audio low-pass filter, a curve showing the frequency response of the filter, or of all the circuitry installed between the modulation limiter and the modulated stage shall be submitted.

AUDIO INPUT VERSUS MODULATION

Rule Part No.: Part 2.1047(b) & 90

Test Requirements:

Method of Measurement: Modulation cannot exceed 100%, The audio input level needed for a particular percentage of modulation was measured in accordance with ANSI/TIA 603-C: 2004. The audio input curves versus modulation are shown below. Curves are provided for several audio input frequencies.

Test data: Please see other files associated with the report

<u>File Name</u>	<u>Description</u>
Curve DEVvsFREQ 12.5KHz.pdf	12.5 kHz audio response test data and plot
Curve DEVvsFREQ 25KHz.pdf	25 kHz audio response test data and plot
Curve DEVvsLVL 12.5KHz.pdf	12.5 kHz modulation test data and plot
Curve DEVvsLVL 25KHz.pdf	25 kHz modulation test data and plot

Other Modulation Characteristics

Part 2.1033(c)

Part 2.1033(c) (4) Type of Emission: 11K0F1D

Part 90.209

Part 90.207 $B_n = 2M + 2DK$

$$M = B/2 = 9600/2 = 4800$$

$$D = 700$$

$$K=1$$

$$B_n = 2(4800) + 2(700) = 11.0k$$

Part 2.1033(c)

Part 2.1033(c) (4) Type of Emission: 8K1F1W

Part 90.209

Part 90.207 $B_n = 2M + 2DK$

$$M = B/2 = 4800/2 = 2400$$

$$D = 700$$

$$K=1$$

$$B_n = 2(2400) + 2(1650) = 8.1k$$

Part 2.1033(c) (4) Type of Emission: 11K0F3E

Part 90.209

Part 90.207 $B_n = 2M + 2DK$

$$M = 3000$$

$$D = 2500$$

$$K=1$$

$$B_n = 2(3000) + 2(2500) = 11.0k$$

Part 2.1033(c) (4) Type of Emission: 16K0F3E

Part 90.209

Part 90.207 $B_n = 2M + 2DK$

$$M = 3000$$

$$D = 5000$$

$$K=1$$

$$B_n = 2(3000) + 2(5000) = 16.0k$$

Test Data: See the plots below

NOTES:

TELTRONIC, S.A.U - Product description: 450-470 MHz 2-WAY TRANSCEIVER
OCCUPIED BANDWIDTH PLOT

FCC 90.210 Mask D

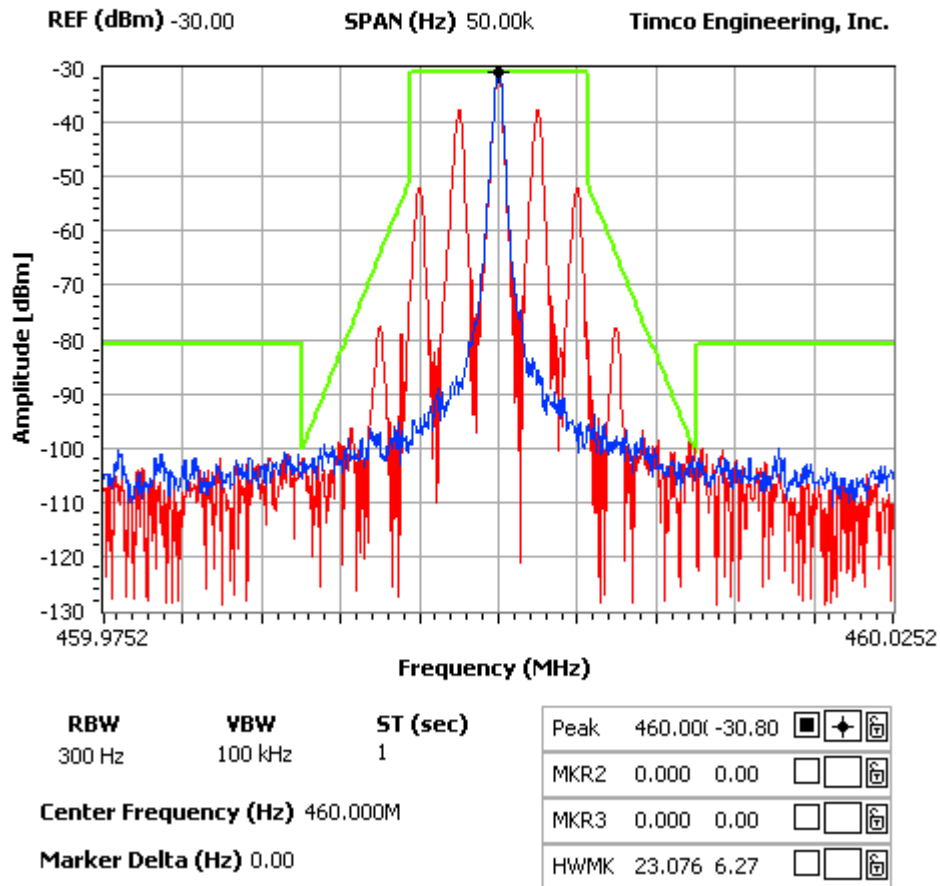

NOTES:

TELTRONIC, S.A.U - Product description: RF Unit Base Station Radio/Repeater
OCCUPIED BANDWIDTH PLOT

FCC 90.210 Mask C

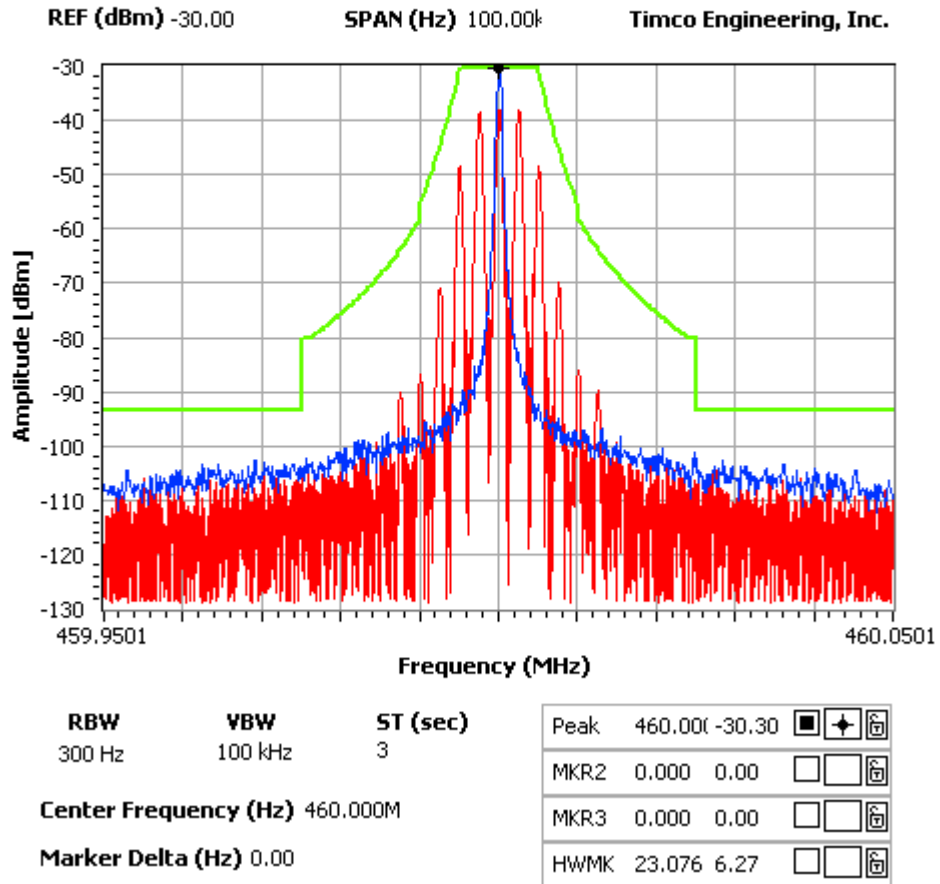

Spurious Emissions At Antenna Terminals (Conducted)

Rule Part No.: FCC Part 2.1051(a), RSS-GEN 7.1.4, ANSI/TIA 603-C:2004

Requirements: 25 kHz Channel Spacing

$$43 + 10\log(p) = 43 + 10\log(100) = 63 \text{ dBc}$$

$$12.5 \text{ kHz Spacing} = 70.0$$

$$50 + 10\log(p) = 50 + 10\log(100) = 70 \text{ dBc}$$

$$6.25 \text{ kHz Channel Spacing} = \text{N/A}$$

Test Data:

TF	EF	dB below carrier	TF	EF	dB below carrier	TF	EF	dB below carrier
450.00	900.00	92.38	460.00	920.00	91.85	470.00	940.00	91.59
	1350.00	88.69		1380.00	87.76		1410.00	88.41
	1800.00	89.34		1840.00	89.74		1880.00	89.26
	2250.00	90.02		2300.00	89.71		2350.00	89.66
	2700.00	NF		2760.00	89.68		2820.00	89.51
	3150.00	NF		3220.00	NF		3290.00	NF
	3600.00	NF		3680.00	NF		3760.00	NF
	4050.00	NF		4140.00	NF		4230.00	NF
	4500.00	NF		4600.00	NF		4700.00	NF

Field Strength Of Spurious Emissions

Rule Parts. No.: FCC Part 2.1053, RSS-GEN 4.9, ANSI/TIA 603-C:2004

Requirements: The FCC limits for radiated emissions are the same as previously stated for the conducted emissions.

Test Data:

TF	EF	Ant Polarity	dB below carrier
450.00	900.00	H	117.05
	1350.00	V	102.97
	1800.00	V	99.91
	2250.00	H	111.43
	2700.00	V	102.04
	3150.00	V	104.76
	3600.00	H	102.13
	4050.00	H	104.67
	4500.00	H/V	NF

TF	EF	Ant Polarity	dB below carrier
460.00	920.00	H	109.39
	1380.00	V	109.66
	1840.00	V	105.09
	2300.00	H/V	NF
	2760.00	V	99.40
	3220.00	V	102.31
	3680.00	H	99.03
	4140.00	V	104.77
	4600.00	H/V	NF

[Continued]

TF	EF	Ant Polarity	dB below carrier
470.00	940.00	H	110.93
	1410.00	V	105.14
	1880.00	V	93.16
	2350.00	V	111.46
	2820.00	V	95.66
	3290.00	V	91.47
	3760.00	H	93.43
	4230.00	H	102.68
	4700.00	V	105.58

Frequency Stability

Rule Parts. No.: FCC Part 2.1055, Part 90.213, RSS-119 5.3, RSS-GEN 7.2.4, ANSI/TIA 603-C: 2004

Requirements: Temperature range requirements: -30 to +50° C.
Voltage Variation +, -15%
±1.5 PPM

Test Data:

Assigned Frequency (Ref. Frequency) (MHz)		460.000059
Temperature (°C)	Frequency (MHz)	Frequency Stability (PPM)
-30	460.000049	-0.02
-20	460.000052	-0.02
-10	460.000055	-0.01
0	460.000056	-0.01
+10	460.000057	0.00
+20	460.000058	0.00
+30	460.000059	0.00
+40	460.000062	0.01
+50	460.000063	0.01

Assigned Frequency (Ref. Frequency) (MHz)		460.000059
% Battery (%)	Frequency (MHz)	Frequency Stability (PPM)
-15%	460.000054	-0.01
	460.000059	0
+15%	460.000062	0.01

Transient Frequency Behavior

Rule Part No.: FCC Part 2.1055(a)(1), FCC Part 90.214, IC RSS-119 5.8

Requirements: Transmitters designed to operate in the 150-174 MHz and 421-512 MHz frequency bands must maintain transient frequencies within the maximum transient frequencies within the maximum frequency difference limits during the time intervals indicated:

Time Intervals	Maximum frequency Difference	All Equipment	
		150-174 MHz	421-512 MHz
Equipment Designed to Operate on 25 kHz Channels			
t_1^4	± 25.0 kHz	5.0 ms	10.0 ms
t_2	± 12.5 kHz	20.0 ms	25.0 ms
t_3^4	± 25.0 kHz	5.0 ms	10.0 ms
Equipment Designed to Operate on 12.5 kHz Channels			
t_1^4	± 12.5 kHz	5.0 ms	10.0 ms
t_2	± 6.25 kHz	20.0 ms	25.0 ms
t_3^4	± 12.5 kHz	5.0 ms	10.0 ms
Equipment Designed to Operate on 6.25 kHz Channels			
t_1^4	± 6.25 kHz	5.0 ms	10.0 ms
t_2	± 3.125 kHz	20.0 ms	25.0 ms
t_3^4	± 6.25 kHz	5.0 ms	10.0 ms

