

**FCC LISTED, REGISTRATION
 NUMBER: 720267**

Test report No:

NIE: 48664RRF.001

Test report REFERENCE STANDARD: USA FCC Part 22

Identificación del objeto ensayado.....: Identification of item tested	RF transceiver
Marca Trademark	PowerTrunk Inc.
Modelo y/o referencia tipo Model and /or type reference	BSR75 -8
Other identification of the product	FCC ID: WT7PTRNKTBSR75450
Final HW version	CCP: 27.26.27
Final SW version	CCP: 27.26.27
Características Features	<p>Nominal voltage: 26.4 Vdc (21.1 – 31.7 Vdc) Frequency Band: 450-470 MHz RF Output Power: 75 W (+48.75 dBm) and from 40 W to 0.6 W in 2 dB steps. Access scheme: TDMA with 4 physical channels per RF channel. RF Channel Bandwidth (Channel spacing): 25 kHz. Spectrum efficiency: one voice channel per 6.25 kHz of channel bandwidth. Modulation scheme: $\pi/4$-DQPSK with 18 Ksym/sec modulation rate, equivalent to 36 Kbits/sec. Data rate on each physical channel: 9000 bits/sec. per 6.25 KHz of channel bandwidth. Modulation low pass filter: Root-raised-cosine filter (RRC), with a previous audio filter. Emissions Designators: 20 KHz Bandwidth Modulation: 20K0D7W, 20K0D7E, 20K0D7D 22 KHz Bandwidth Modulation: 22K0D7W, 22K0D7E, 22K0D7D Note: For this certification process (C2PC) only 20KHz Bandwidth Modulation will be tested and therefore granted.</p>
Fabricante Manufacturer	<p>TELTRONIC, S.A.U. Polígono Malpica, Calle F-Oeste (50016). Zaragoza. SPAIN.</p>
Método de ensayo solicitado, norma.....: Test method requested, standard	<p>USA FCC Part 22 10-1-15 Edition. Measurement Guidance 971168 D01 v02r02 for certification of Licensed Digital Transmitters. ANSI/TIA-603-D (2010).</p>
Resultado.....: Summary	IN COMPLIANCE

Aprobado por (nombre / cargo y firma) Approved by (name / position & signature)	A. Llamas RF Lab. Manager
Fecha de realización Date of issue	2016-03-14
Formato de informe No..... Report template No	FDT08_17

Index

Competences and guarantees.....	4
General conditions.....	4
Uncertainty	4
Usage of samples.....	4
Test sample description	5
Identification of the client	5
Testing period.....	5
Environmental conditions.....	5
Remarks and comments.....	6
Testing verdicts	7
Appendix A – Test result for FCC Part 22	8

Competences and guarantees

AT4 wireless is a laboratory with a measurement facility in compliance with the requirements of Section 2.948 of the FCC rules and has been added to the list of facilities whose measurements data will be accepted in conjunction with applications for Certification under Parts 15 or 18 of the Commission's Rules. Registration Number: 720267.

In order to assure the traceability to other national and international laboratories, AT4 wireless has a calibration and maintenance program for its measurement equipment.

AT4 wireless guarantees the reliability of the data presented in this report, which is the result of the measurements and the tests performed to the item under test on the date and under the conditions stated on the report and, it is based on the knowledge and technical facilities available at AT4 wireless at the time of performance of the test.

AT4 wireless is liable to the client for the maintenance of the confidentiality of all information related to the item under test and the results of the test.

The results presented in this Test Report apply only to the particular item under test established in this document.

IMPORTANT: No parts of this report may be reproduced or quoted out of context, in any form or by any means, except in full, without the previous written permission of AT4 wireless.

General conditions

1. This report is only referred to the item that has undergone the test.
2. This report does not constitute or imply on its own an approval of the product by the Certification Bodies or competent Authorities.
3. This document is only valid if complete; no partial reproduction can be made without previous written permission of AT4 wireless.
4. This test report cannot be used partially or in full for publicity and/or promotional purposes without previous written permission of AT4 wireless and the Accreditation Bodies.

Uncertainty

Uncertainty (factor $k=2$) was calculated according to the AT4 wireless internal document PODT000.

Usage of samples

Samples undergoing test have been selected by: **the client**.

Sample S/01 is composed of the following elements:

Control N°	Description	Model	Serial N°	Date of reception
48664/001	RF transceiver	BSR75 -8	892655	2016-02-03
48664/002	Power supply cable	---	---	2016-02-03
48664/003	Ethernet cable	---	---	2016-02-03

1. Sample S/01 has undergone the test(s).
All tests indicated in appendix A.

Test sample description

The test sample consists of a digital RF transceiver based on TETRA Technology.

Identification of the client

TELTRONIC, S.A.U.

Polígono Malpica, Calle F-Oeste (50016). Zaragoza. SPAIN.

Testing period

The performed test started on 2016-02-14 and finished on 2016-02-25.

The tests have been performed at AT4 wireless.

Environmental conditions

In the control chamber, the following limits were not exceeded during the test:

Temperature	Min. = 15 °C Max. = 35 °C
Relative humidity	Min. = 20 % Max. = 75 %
Shielding effectiveness	> 100 dB
Electric insulation	> 10 kΩ
Reference resistance to earth	< 1 Ω

In the semianechoic chamber the following limits were not exceeded during the test.

Temperature	Min. = 15 °C Max. = 35 °C
Relative humidity	Min. = 20 % Max. = 75 %
Air pressure	Min. = 860 mbar Max. = 1060 mbar
Shielding effectiveness	> 100 dB
Electric insulation	> 10 kΩ
Reference resistance to earth	< 1 Ω
Normal site attenuation (NSA)	< ±4 dB at 10 m distance between item under test and receiver antenna, (30 MHz to 1000 MHz)
Field homogeneity	More than 75% of illuminated surface is between 0 and 6 dB (26 MHz to 1000 MHz).

In the chamber for conducted measurements the following limits were not exceeded during the test:

Temperature	Min. = 22.7 °C Max. = 25.2 °C
Relative humidity	Min. = 49.9 % Max. = 47.3 %
Air pressure	Min. = 1019 mbar Max. = 1019 mbar
Shielding effectiveness	> 100 dB
Electric insulation	> 10 kΩ
Reference resistance to earth	< 1 Ω

Remarks and comments

1: Used instrumentation.

Conducted Measurements

		Last Cal. date	Cal. due date
1.	Spectrum analyser Agilent PSA E4440A	2015/05	2017/05
2.	Climatic chamber CTS C40/200Li	2015/05	2016/05
3.	DC power supply R&S NGPE 40/40	2014/11	2017/11
4.	Radiocommunication analyser R&S CMTA84	2015/07	2018/07
5.	Wideband Power sensor R&S NRP-Z81	2014/03	2016/03

Radiated Measurements

		Last Cal. date	Cal. due date
1.	Semianechoic Absorber Lined Chamber ETS FACT3 200STP	N.A.	N.A.
2.	BiconicalLog antenna ETS LINDGREN 3142E	2014/03	2017/03
3.	Multi Device Controller EMCO 2090	N.A.	N.A.
4.	Double-ridge Guide Horn antenna 1-18 GHz SCHWARZBECK BBHA 9120 D	2013/11	2016/11
5.	EMI Test Receiver R&S ESU 40	2014/02	2016/02
6.	Spectrum analyser Rohde & Schwarz FSW50	2015/12	2017/12
7.	RF pre-amplifier 10 MHz-6 GHz SCHWARZBECK BBV9743	2015/03	2016/03
8.	RF pre-amplifier 1-18 GHz BONN ELEKTRONIK BLMA 0118-3A	2015/05	2016/05
9.	DC power supply R&S NGPE 40/40	2014/11	2017/11

2: This information has been provided by the applicant.

Testing verdicts

Not applicable	N/A
Pass	P
Fail	F
Not measured	N/M

FCC PART 22 PARAGRAPH	VERDICT			
	NA	P	F	NM
Clause 2.1047: Modulation characteristics				NM ²
Clause 2.1046 and 22.727, 22.809: RF output power		P		
Clause 2.1055 and 22.863: Frequency stability		P		
Clause 2.1049 and 22.863: Occupied Bandwidth		P		
Clause 22.357, 22.359, 22.731, 22.861: Spurious emissions at antenna terminals		P		
Clause 22.357, 22.359, 22.731, 22.861: Band-edge emissions compliance		P		
Clause 22.357, 22.359, 22.731, 22.861: Radiated emissions		P		

2: see point "Remarks and comments".

Appendix A – Test result for FCC Part 22

INDEX

TEST CONDITIONS	10
Modulation Characteristics	11
RF Output Power (conducted)	12
Occupied Bandwidth	14
Frequency Stability	16
Spurious emissions at antenna terminals	18
Band-edge emissions compliance (Transmitter).....	21
Radiated emissions	23

TEST CONDITIONS

Power supply (V):

$$V_{\text{nom}} = 26.40 \text{ Vdc}$$

$$V_{\text{max}} = 30.36 \text{ Vdc}$$

$$V_{\text{min}} = 22.44 \text{ Vdc}$$

The subscripts nom, min and max indicate voltage test conditions (nominal, minimum and maximum respectively, as declared by the applicant).

Type of power supply = DC Voltage from external power supply

Type of antenna = external connectable antenna

RF Nominal Output Power: 75 W (+48.75 dBm).

TEST FREQUENCIES:

Lowest channel: 454.025 MHz

Highest channel: 454.975 MHz

Modulation Characteristics

SPECIFICATION

FCC §2.1047

(a) Voice modulated communication equipment. A curve or equivalent data showing the frequency response of the audio modulating circuit over a range of 100 to 5000 Hz shall be submitted. For equipment required to have an audio low-pass filter, a curve showing the frequency response of the filter, or of all circuitry installed between the modulation limiter and the modulated stage shall be submitted.

(b) Equipment which employs modulation limiting. A curve or family of curves showing the percentage of modulation versus the modulation input voltage shall be supplied. The information submitted shall be sufficient to show modulation limiting capability throughout the range of modulating frequencies and input modulating signal levels employed.

(c) Single sideband and independent sideband radiotelephone transmitters which employ a device or circuit to limit peak envelope power. A curve showing the peak envelope power output versus the modulation input voltage shall be supplied. The modulating signals shall be the same in frequency as specified in paragraph (c) of § 2.1049 for the occupied bandwidth tests.

(d) Other types of equipment. A curve or equivalent data which shows that the equipment will meet the modulation requirements of the rules under which the equipment is to be licensed.

RESULTS (The following information has been provided by the applicant).

The modulation used is $\pi/4$ -shifted Differential Quaternary Phase Shift Keying ($\pi/4$ -DQPSK), with a modulation rate of 18 ksymbols/sec (36 Kbits/sec).

The access scheme is TDMA with 4 physical channels per carrier.

Audio low pass filter response for 20 kHz bandwidth modulation:

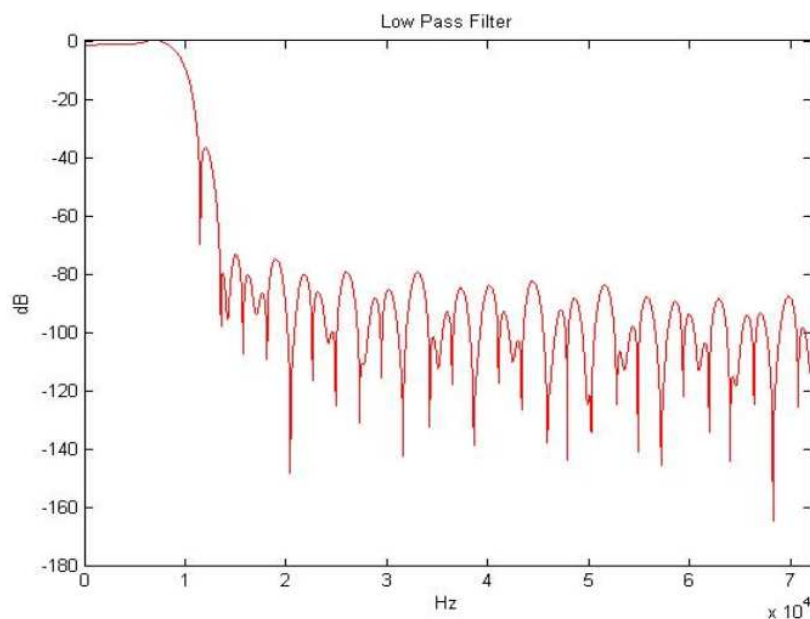

RF Output Power (conducted)

SPECIFICATION

§2.1046, 22.727, 22.809.

FCC 22.727

(a) The Effective Radiated Power (E.R.P.) of central office and rural subscriber station transmitters must not exceed the applicable limits in this paragraph under any circumstances.

Frequency range (MHz)	Maximum ERP (watts)
152-153	1400
157-159	150
454-455	3500
459-460	150

(b) *Basic power limit.* Except as provided in paragraph (d) of this section, the ERP of central office station transmitters must not exceed 500 Watts.

FCC 22.809

The transmitting power of ground and airborne mobile transmitters operating on the channels listed in §22.805 must not exceed the limits:

(a) Ground station transmitters. The effective radiated power of ground stations must not exceed 100 Watts and must not be less than 50 Watts, except as provided in §22.811.

(b) Airborne mobile transmitters. The transmitter power output of airborne mobile transmitters must not exceed 25 Watts and must not be less than 4 Watts.

METHOD

The EUT was controlled via a terminal emulator of the PC.

The maximum conducted output power was measured using a peak power meter according to point 5.1.2 of Guidance 971168 D01.

The conducted RF output power measurements were made at the RF output terminals of the EUT using an attenuator and a calibrated wideband power sensor.

TEST SETUP

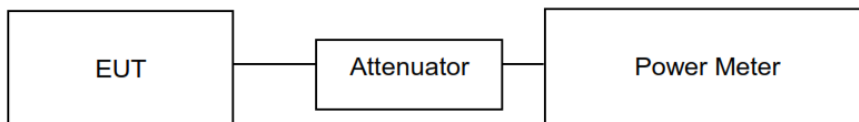

RESULTS

MAXIMUM OUTPUT POWER (CONDUCTED).

20 kHz Bandwidth Modulation	Frequency (MHz)	Maximum average power (dBm) / W
FCC 454-455 MHz band	454.025	48.77 / 75.33
	454.975	48.79 / 75.68
Measurement uncertainty (dB)	<±0.33	

Verdict: PASS

Occupied Bandwidth

SPECIFICATION

FCC §2.1049, §22.863

The occupied bandwidth of the fundamental emissions remains within the authorized frequency bands of operation.

METHOD

The EUT was configured to transmit a modulated carrier signal. An IF bandwidth of 300 Hz was used to determine the occupied bandwidth of the modulated emission. The 99% occupied bandwidth and the -26 dBc bandwidth were measured directly using the built-in bandwidth measuring option of spectrum analyser E4440A.

The occupied Bandwidth was measured according to point 4.2 of Guidance 971168 D01 Power Meas License Digital Systems v02r02.

TEST SETUP

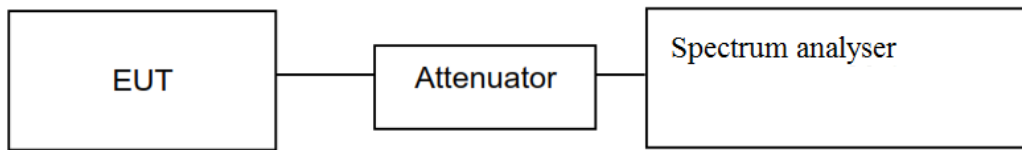

RESULTS (see next plots)

Channel	Lowest	Highest
99% Occupied bandwidth (kHz)	19.1135	19.3061
-26 dBc bandwidth (kHz)	21.381	21.790
Measurement uncertainty (kHz)	<±0.17	

Verdict: PASS

Lowest Channel

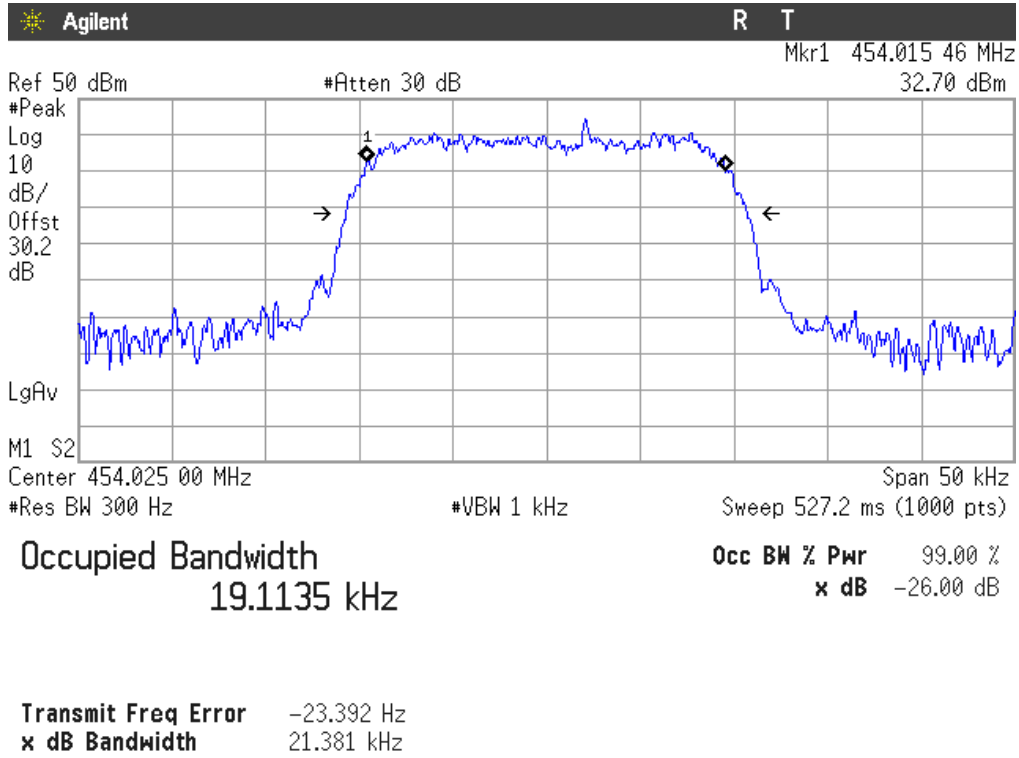

Highest Channel

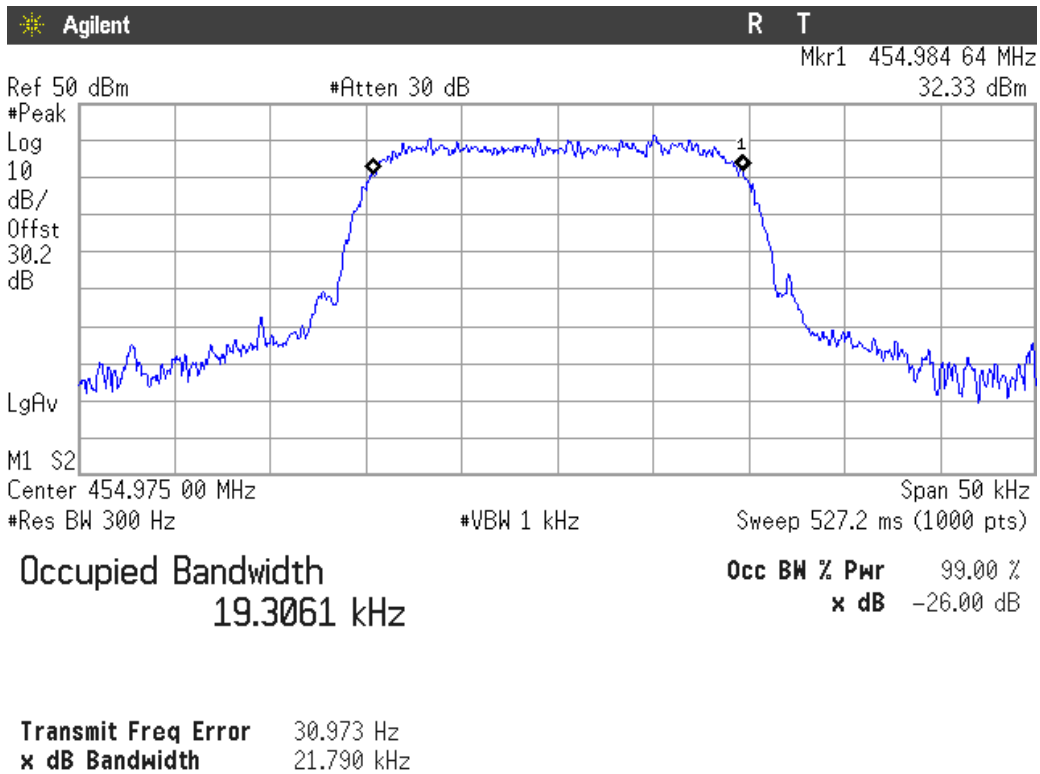

Frequency Stability

SPECIFICATION

FCC §2.1055, §22.863:

METHOD

The frequency tolerance measurements over temperature variations were made over the temperature range of -30°C to $+50^{\circ}\text{C}$. The EUT was placed inside a climatic chamber and the temperature was raised hourly in 10°C steps from -30°C up to $+50^{\circ}\text{C}$.

Frequency Stability vs Voltage: Vary primary supply voltage from 85% to 115% of the nominal value for other than hand carried battery equipment.

For 20 kHz FCC the EUT is set in continuous transmission without modulation (only carrier) and the frequency is measured with the frequency meter of Radiocommunication analyser CMTA84.

TEST SETUP

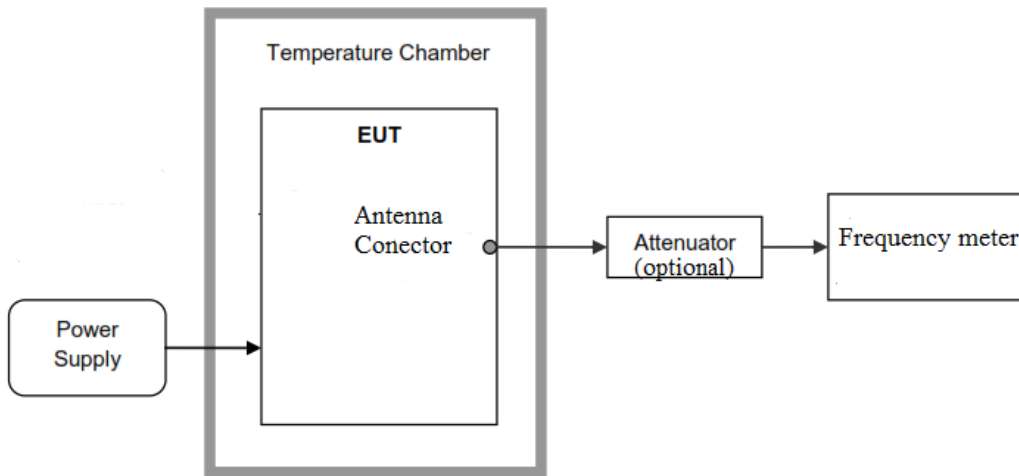

RESULTS

Highest Channel: 454.975 MHz.

Voltage (Vdc)	Temperature (°C)	Frequency Error (Hz)	Frequency Error (ppm)
Frequency stability with Temperature			
26.40	+50	34	0.07473
	+40	27	0.05934
	+30	28	0.06154
	+20	30	0.06594
	+10	25	0.05495
	0	25	0.05495
	-10	27	0.05934
	-20	27	0.05934
	-30	22	0.04835
Frequency stability with Supply Voltage			
22.44	20	25	0.05495
30.36	20	28	0.06154

Measurement uncertainty	$<\pm 3 \times 10^{-8}$
-------------------------	-------------------------

Verdict: PASS

Spurious emissions at antenna terminals

SPECIFICATION

FCC §22.357, §22.359, §22.731, §22.861.

Out of band emissions. The power of any emission outside of the authorized operating frequency ranges must be attenuated below the transmitting power (P) by a factor of at least $43 + 10 \log (P)$ dB.

METHOD

The EUT RF output connector was connected to a spectrum analyser using a 50 ohm attenuator and the resolution bandwidth of the spectrum analyser was set to 100 kHz for frequencies < 1GHz and 1 MHz for frequencies > 1GHz. The spectrum was investigated from 9 kHz to 5 GHz.

The reading of the spectrum analyser is corrected with the attenuation loss of connection between output terminal of EUT and input of the spectrum analyser.

Measurement Limit:

According to specification. the power of emissions shall be attenuated below the transmitter power (P) by a factor of at least $43 + 10 \log (P)$ dB. P in watts.

At P_o transmitting power the specified minimum attenuation becomes $43+10\log (P_o)$ and the level in dBm relative P_o becomes:

$$P_o \text{ (dBm)} - [43 + 10 \log (P_o \text{ in mwatts}) - 30] = - 13 \text{ dBm}$$

TEST SETUP

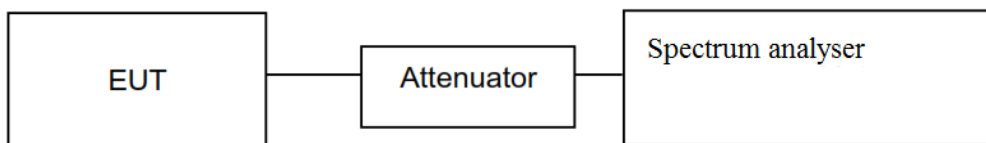

RESULTS (see plots in next pages)

1. CHANNEL: LOWEST

No spurious signals were found at less than 20 dB below the limit in all the range.

2. CHANNEL: HIGHEST

No spurious signals were found at less than 20 dB below the limit in all the range.

Verdict: PASS

Frequency range 9 kHz to 1000 MHz

1. CHANNEL: LOWEST. 454.025 MHz.

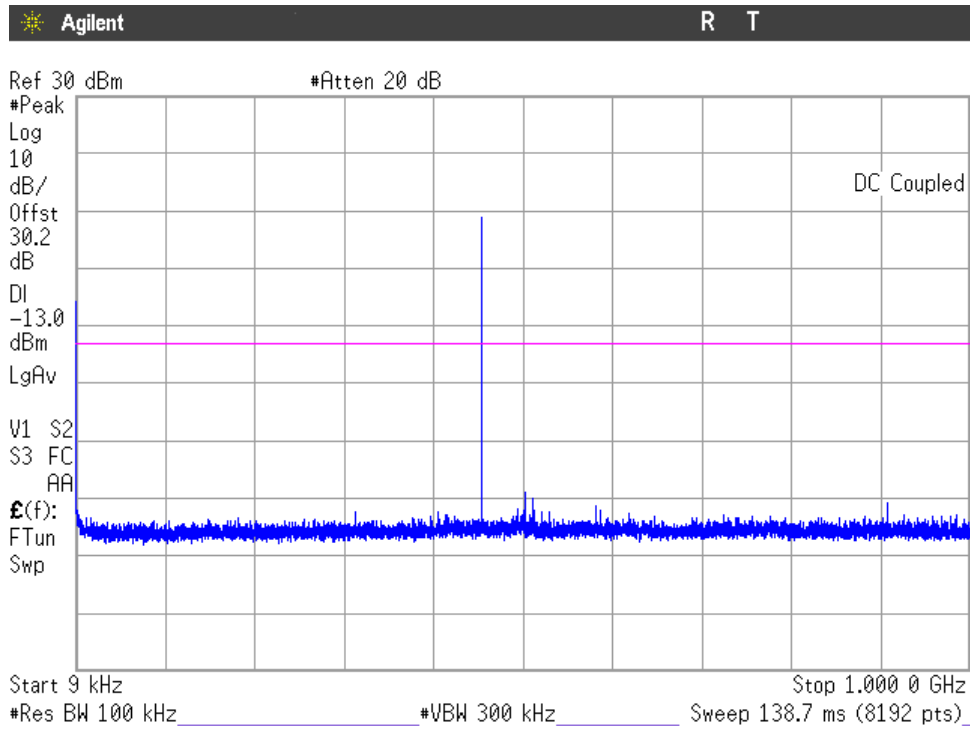

Note: The peak above the limit is the carrier frequency. The carrier was attenuated using a notch filter.

2. CHANNEL: HIGHEST. 454.975 MHz.

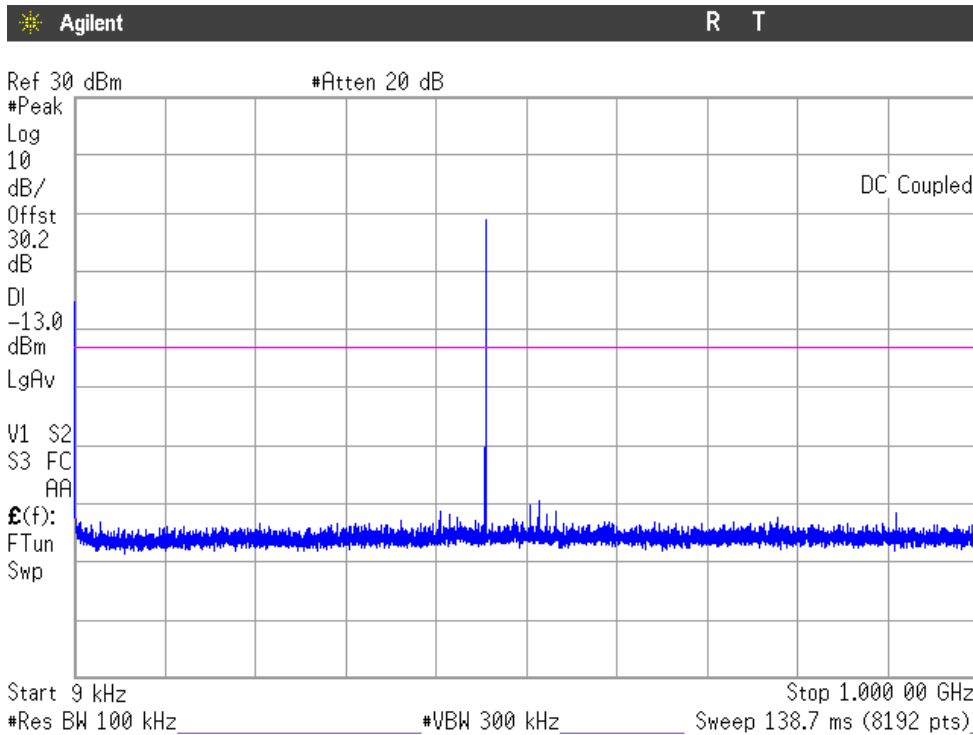

Note: The peak above the limit is the carrier frequency. The carrier was attenuated using a notch filter.

Frequency range 1 GHz to 5 GHz

1. CHANNEL: LOWEST. 454.025 MHz.

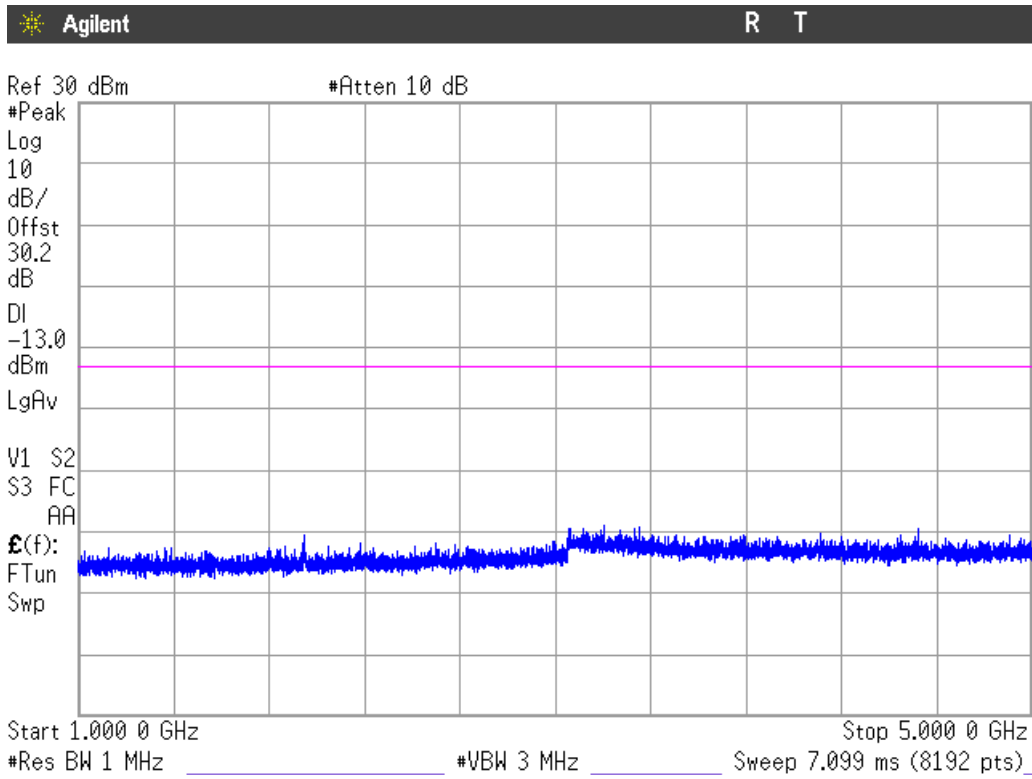

2. CHANNEL: HIGHEST. 454.975 MHz.

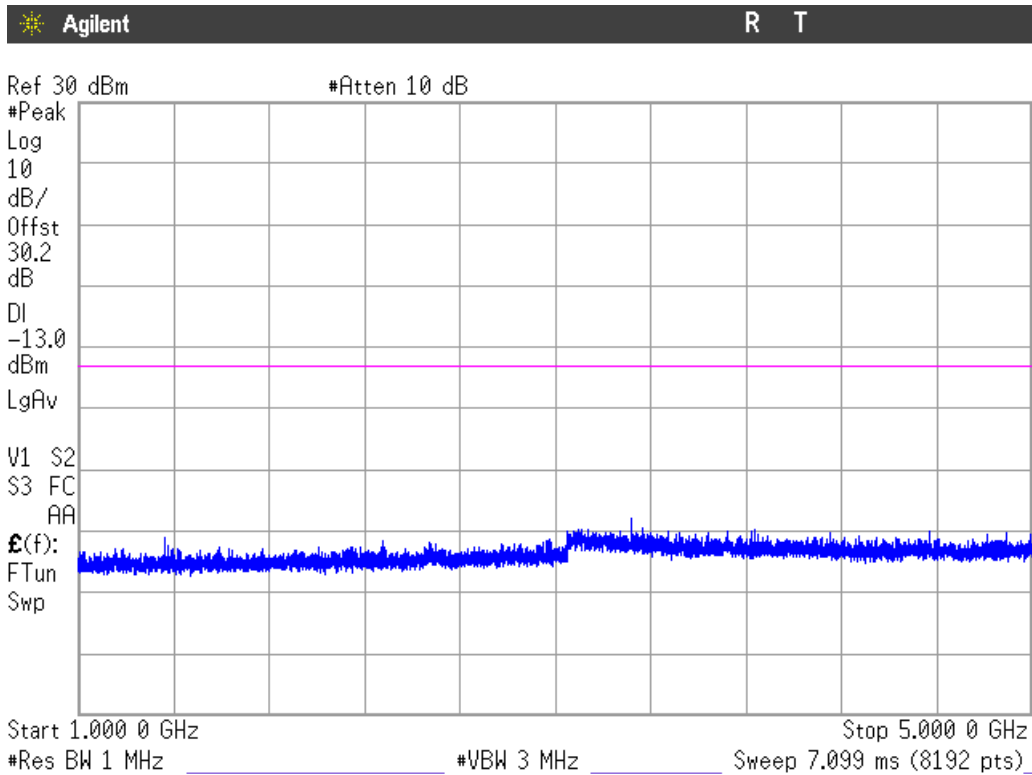

Band-edge emissions compliance (Transmitter)

SPECIFICATION

FCC §22.357, §22.359, §22.731, §22.861.

Out of band emissions. The power of any emission outside of the authorized operating frequency ranges must be attenuated below the transmitting power (P) by a factor of at least 43 + 10 log (P) dB.

METHOD

FCC 22.359

As indicated in FCC part 22.359, in the 60 kHz bands immediately outside and adjacent to the authorized frequency range or channel, a resolution bandwidth of at least one percent of the emission bandwidth of the fundamental emission of the transmitter may be employed. A resolution bandwidth of 300 Hz was used.

FCC 22.861

As indicated in FCC part 22.861, in the 1 MHz bands immediately outside and adjacent to the frequency block, a resolution bandwidth of at least one percent of the emission bandwidth of the fundamental emission of the transmitter may be employed. A resolution bandwidth of 300 Hz was used.

The reading of the spectrum analyser is corrected with the attenuation loss of connection between output terminal of EUT and input of the spectrum analyser.

Measurement Limit:

According to specification. the power of emissions shall be attenuated below the transmitter power (P) by a factor of at least 43 + 10 log (P) dB. P in watts.

At Po transmitting power the specified minimum attenuation becomes 43+10log (Po) and the level in dBm relative Po becomes:

$$Po \text{ (dBm)} - [43 + 10 \log (Po \text{ in mwatts}) - 30] = - 13 \text{ dBm}$$

TEST SETUP

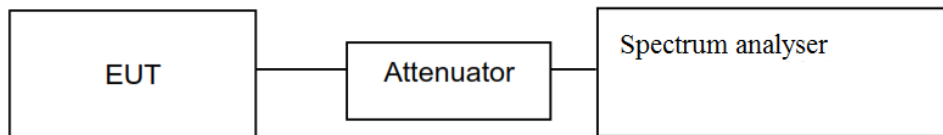

RESULTS (See next plots):

Maximum measured level at lowest Block Edge at antenna port (dBm)	-28.63
Maximum measured level at highest Block Edge at antenna port (dBm)	-27.49
Measurement uncertainty (dB):	< ± 2.03

Verdict: PASS

1. LOW FREQUENCY SECTION. CONDUCTED.

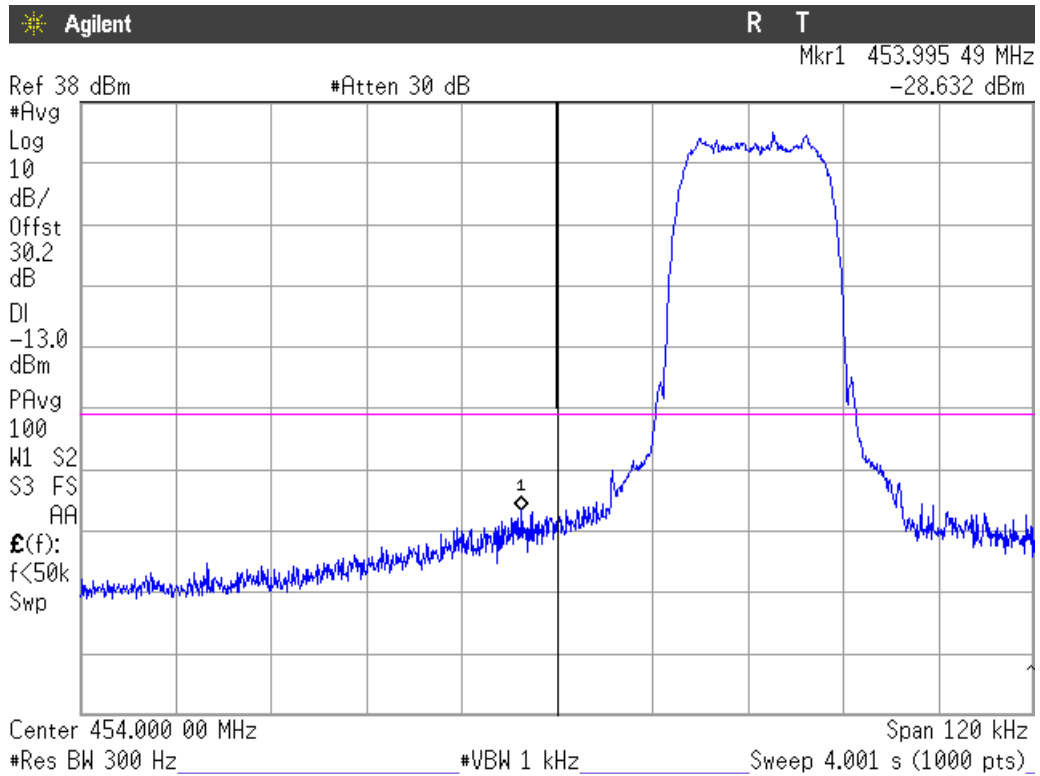

2. HIGH FREQUENCY SECTION. CONDUCTED.

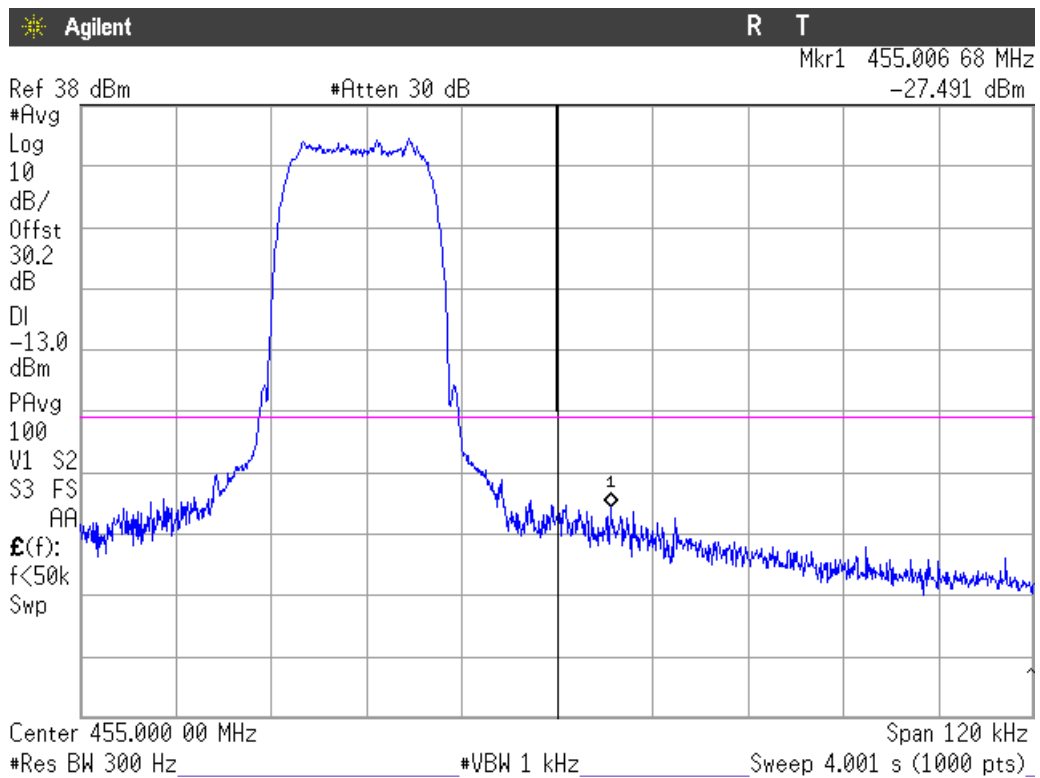

Radiated emissions

SPECIFICATION

FCC §22.357, §22.359, §22.731, §22.861.

Out of band emissions. The power of any emission outside of the authorized operating frequency ranges must be attenuated below the transmitting power (P) by a factor of at least $43 + 10 \log (P)$ dB.

METHOD

The measurement was performed with the EUT inside an anechoic chamber. The RF output connector of the EUT is terminated with an attenuator and a 50 ohm load.

The spectrum was scanned from 30 MHz to at least the 10th harmonic of the highest frequency generated within the equipment.

The EUT was placed on a 1.5 meter high non-conductive stand at a 3 meter distance from the measuring antenna for measurements below 1 GHz and at 1 m distance for measurements above 1 GHz.

Detected emissions were maximized at each frequency by rotating the EUT and adjusting the measuring antenna height and polarization. The maximum meter reading was recorded.

Each detected emission at less than 20 dB below the limit is substituted by the Substitution method in accordance with the ANSI/TIA-603-D.

Measurement Limit:

According to specification, the power of emissions shall be attenuated below the transmitter power (P) by a factor of at least $43 + 10 \log (P)$ dB. P in watts.

At P_o transmitting power the specified minimum attenuation becomes $43+10\log (P_o)$ and the level in dBm relative P_o becomes:

$$P_o \text{ (dBm)} - [43 + 10 \log (P_o \text{ in mwatts}) - 30] = - 13 \text{ dBm}$$

TEST SETUP

Radiated measurements below 1 GHz.

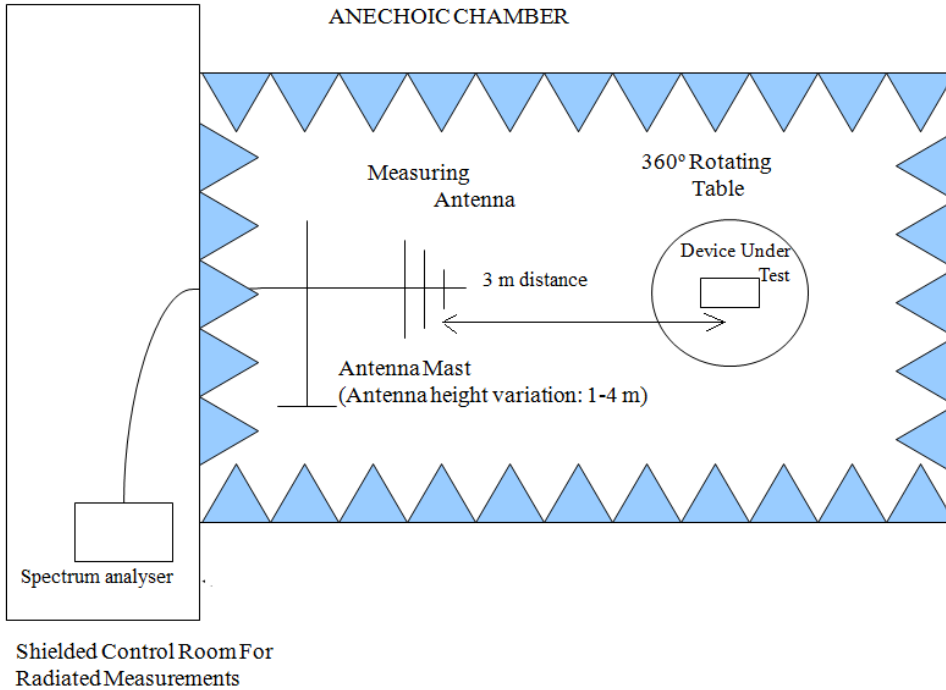

Radiated measurements above 1 GHz.

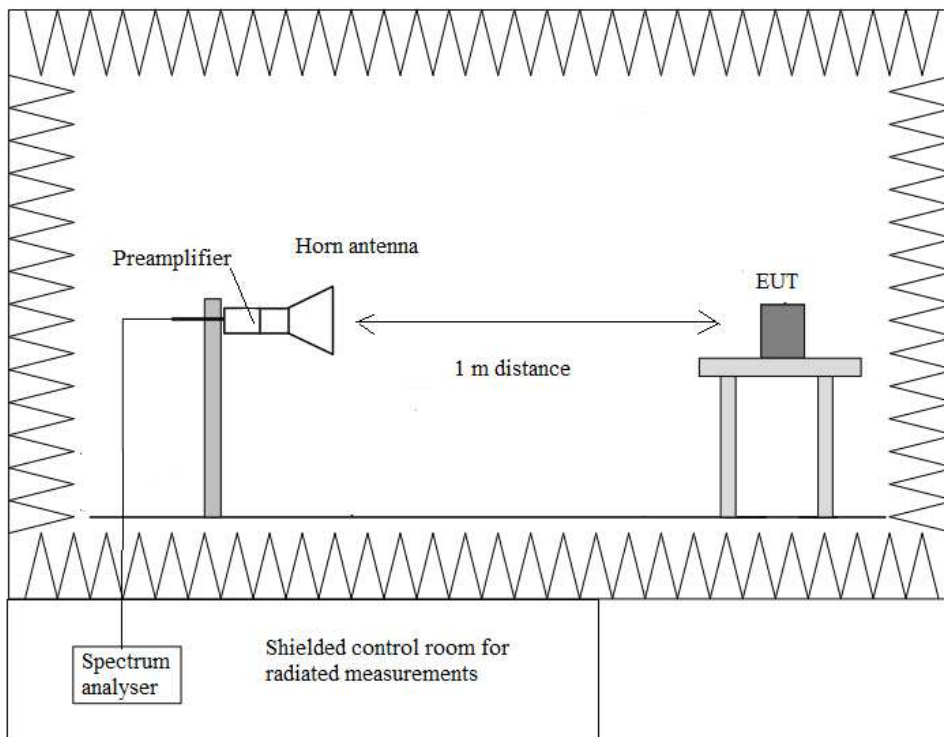

RESULTS

1. CHANNEL: LOWEST. 454.025 MHz.

Frequency range 30 MHz-1000 MHz.

No spurious signals were found at less than 20 dB below the limit in all the range.

Frequency range 1 GHz-5 GHz.

Substitution method data

Frequency (MHz)	Instrument reading (dBm)	Polarization	(1) Generator output (dBm)	(2) Cable loss (dB)	(3) Substitution antenna gain Gi (respect to isotropic radiator) (dB)	E.I.R.P. (dBm) = (1) – (2) + (3)
1362.07	-24.72	Horizontal	-35.60	1.46	7.36	-29.71

Measurement uncertainty (dB):	< ± 4.87
-------------------------------	----------

2. CHANNEL: HIGHEST. 454.975 MHz.

Frequency range 30 MHz-1000 MHz.

No spurious signals were found at less than 20 dB below the limit in all the range.

Frequency range 1 GHz-5 GHz.

Substitution method data

Frequency (MHz)	Instrument reading (dBm)	Polarization	(1) Generator output (dBm)	(2) Cable loss (dB)	(3) Substitution antenna gain Gi (respect to isotropic radiator) (dB)	E.I.R.P. (dBm) = (1) – (2) + (3)
1364.87	-24.95	Vertical	-35.84	1.46	7.37	-29.93

Measurement uncertainty (dB):	< ± 4.87
-------------------------------	----------

Verdict: PASS

FREQUENCY RANGE 30 MHz-1000 MHz.

1. CHANNEL: LOWEST.

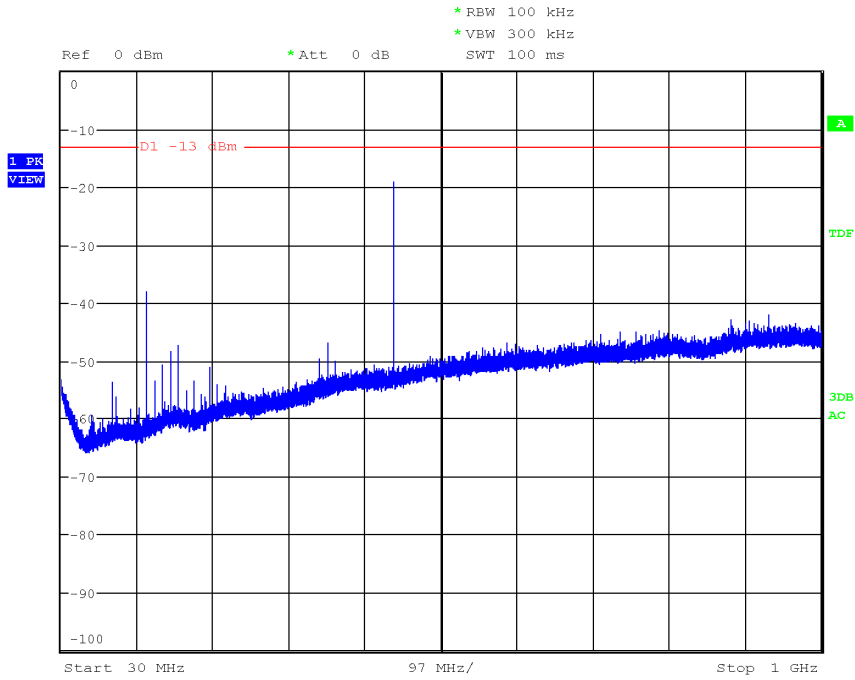

Note: The highest peak shown in the above plot is the carrier frequency.

CHANNEL: HIGHEST

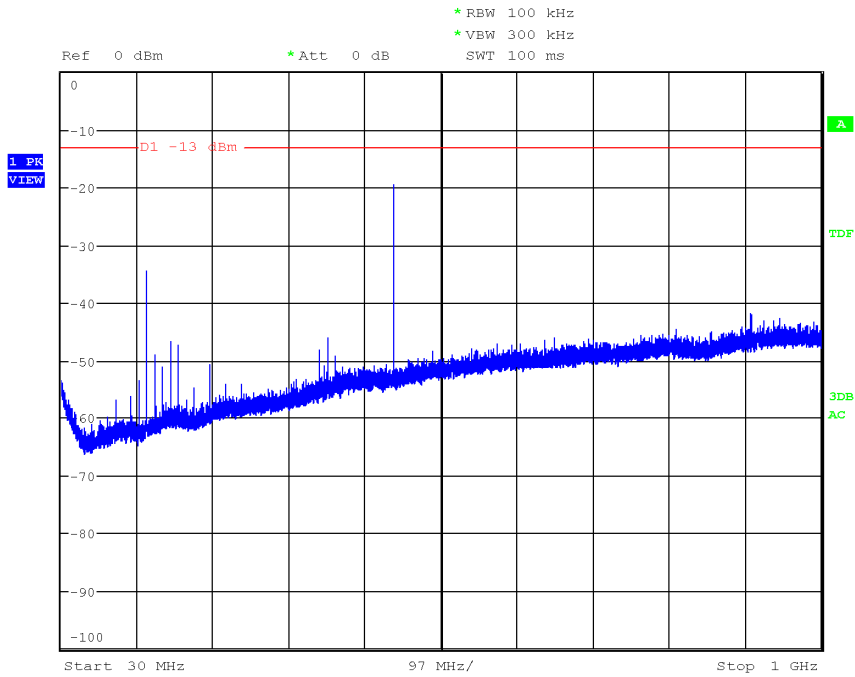

Note: The highest peak shown in the above plot is the carrier frequency.

FREQUENCY RANGE 1 GHz to 5 GHz.

CHANNEL: LOWEST

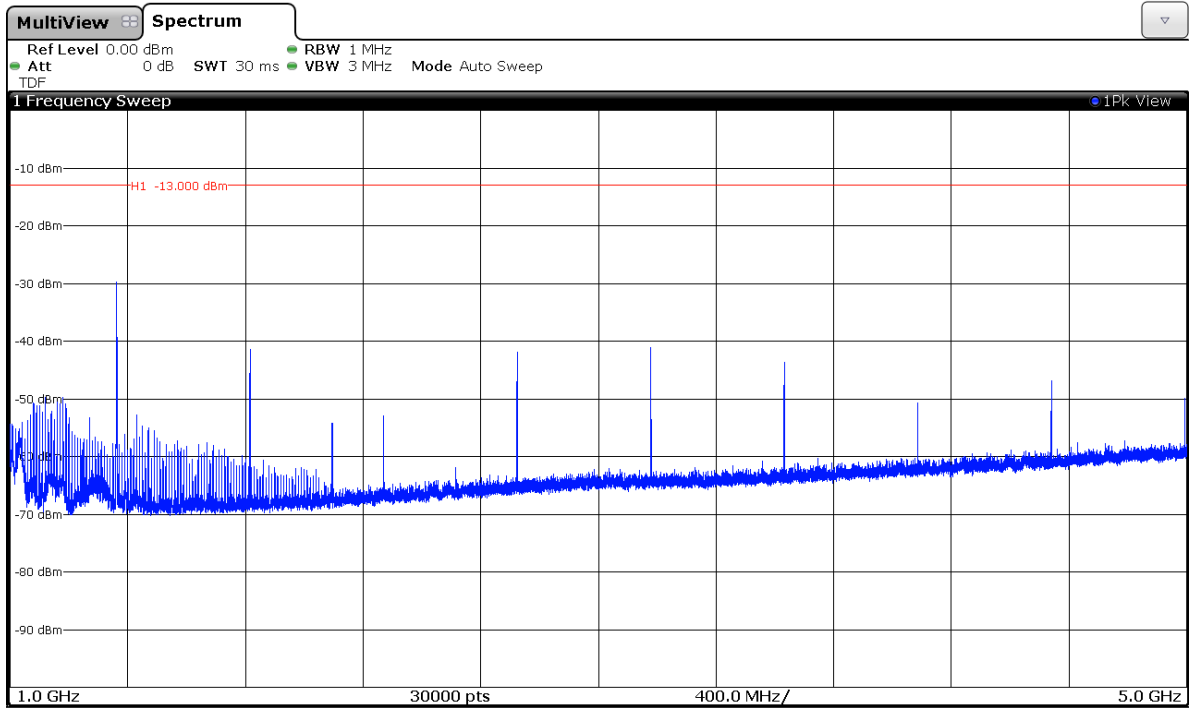

CHANNEL: HIGHEST

