



849 NW STATE ROAD 45
 NEWBERRY, FL 32669 USA
 PH: 888.472.2424 OR 352.472.5500
 FAX: 352.472.2030
 EMAIL: INFO@TIMCOENGR.COM
[HTTP://WWW.TIMCOENGR.COM](http://WWW.TIMCOENGR.COM)

FCC PART 90 AND IC RSS-119, RSS-GEN TEST REPORT

APPLICANT	TELTRONIC, S.A.U.
	POLIGONO MALPICA CALLE F PARCELA 12 ZARAGOZA 50057 SPAIN
FCC ID	WT7PTRNKTBSR75410
IC CERTIFICATION	8624A-PTRKT410
MODEL NUMBER	BSR75 409-430 MHz
PRODUCT DESCRIPTION	BSR75 409-430 MHz BASE STATION RADIO/REPEATER
DATE SAMPLE RECEIVED	8/18/2010
DATE TESTED	9/7/2010
TEST REPORT REVISED	11/29/2010
TESTED BY	Nam Nguyen
APPROVED BY	Mario de Aranzeta
TIMCO REPORT NO.	1963AT10TestReport.doc
TEST RESULTS	<input checked="" type="checkbox"/> PASS <input type="checkbox"/> FAIL

**THE ATTACHED REPORT SHALL NOT BE REPRODUCED EXCEPT IN FULL
 WITHOUT THE WRITTEN APPROVAL OF TIMCO ENGINEERING, INC.**





TABLE OF CONTENTS

GENERAL REMARKS	3
GENERAL INFORMATION	4
TEST PROCEDURES	5
RF POWER OUTPUT	6
MODULATION CHARACTERISTICS	7
AUDIO FREQUENCY RESPONSE	8
AUDIO INPUT VERSUS MODULATION	8
AUDIO LOW PASS FILTER	9
OCCUPIED BANDWIDTH	10
OCCUPIED BANDWIDTH	11
SPURIOUS EMISSIONS AT ANTENNA TERMINALS (CONDUCTED).....	14
FIELD STRENGTH OF SPURIOUS EMISSIONS.....	17
RECEIVER RADIATED SPURIOUS EMISSIONS	19
FREQUENCY STABILITY	21
TRANSIENT FREQUENCY BEHAVIOR.....	22
EMC EQUIPMENT LIST	25

Applicant: TELTRONIC, S.A.U
FCC ID: WT7PTRNKTBSR75410
IC CERT #: 8624A-PTRKT410
Report: T\TELTRONIC S.A.U\1963AT10\1963AT10TestReport.doc

GENERAL REMARKS

The attached report shall not be reproduced except in full without the written permission of Timco Engineering Inc.

The test results relate only to the items tested.

Summary

The device under test does:

- fulfill the general approval requirements as identified in this test report
- not fulfill the general approval requirements as identified in this test report

Attestations

This equipment has been tested in accordance with the standards identified in this test report. To the best of my knowledge and belief, these tests were performed using the measurement procedures described in this report.

All instrumentation and accessories used to test products for compliance to the indicated standards are calibrated regularly in accordance with ISO 17025: 2005 requirements.



Testing Certificate # 0955-01

I attest that the necessary measurements were made, under my supervision, at:

Timco Engineering Inc.
849 NW State Road 45
Newberry, Fl 32669



Authorized Signatory Name:

Mario de Aranzeta C.E.T.
Compliance Engineer/ Lab. Supervisor

Date: September 9th, 2010

Applicant: TELTRONIC, S.A.U
FCC ID: WT7PTRNKTBSR75410
IC CERT #: 8624A-PTRKT410
Report: T\TELTRONIC S.A.U\1963AT10\1963AT10TestReport.doc

GENERAL INFORMATION
DUT Specification

DUT Description	BSR75 406-430 MHZ BASE STATION RADIO/REPEATER
FCC ID	WT7PTRNKTBSR75410
IC Certification	8624A-PTRKT410
Model Number	BSR75 409-430 MHz
Serial Number	N/A
Operating Frequency	(409-430) MHz
Test Frequencies	(409.0, 419.5, and 430.0) MHz
Type of Emission	20K0D7W, 20K0D7E, and 20K0D7D
Modulation	$\pi/4$ DQPSK
DUT Power Source	<input type="checkbox"/> 110-120Vac/50- 60Hz
	<input checked="" type="checkbox"/> DC Power 26.4V
	<input type="checkbox"/> Battery Operated Exclusively
Test Item	<input type="checkbox"/> Prototype
	<input checked="" type="checkbox"/> Pre-Production
	<input type="checkbox"/> Production
Type of Equipment	<input checked="" type="checkbox"/> Fixed
	<input type="checkbox"/> Mobile
	<input type="checkbox"/> Portable
Test Conditions	The temperature was 26°C with a relative humidity of 50%.
Modification to the DUT	None
Test Exercise	The DUT was placed in continuous transmit mode.
Applicable Standards	ANSI/TIA 603-C:2004, FCC CFR 47 Part 90, IC RSS-119, RSS-GEN
Test Facility	Timco Engineering Inc. at 849 NW State Road 45 Newberry, FL 32669 USA.

Applicant: TELTRONIC, S.A.U
 FCC ID: WT7PTRNKTBSR75410
 IC CERT #: 8624A-PTRKT410
 Report: T\TELTRONIC S.A.U\1963AT10\1963AT10TestReport.doc

TEST PROCEDURES

Power Line Conducted Interference: The procedure used was ANSI/TIA 603-C:2004 using a 50uH LISN. Both lines were observed with the DUT transmitting. The bandwidth of the spectrum analyzer was 10 kHz with an appropriate sweep speed.

Bandwidth 20 dB: The measurements were made with the spectrum analyzer's resolution bandwidth (RBW) = 1 MHz and the video bandwidth (VBW) = 3 MHz and the span set as shown on plot.

Power Output: The RF power output was measured at the antenna feed point using a peak power meter.

Antenna Conducted Emissions: The RBW = 100 kHz, VBW = 300 kHz and the span set to 10.0 MHz and the spectrum was scanned from 30 MHz to the 10th harmonic of the fundamental. Above 1 GHz the resolution bandwidth was 1 MHz and the VBW = 3 MHz and the span to 50 MHz.

Radiation Interference: The test procedure used was ANSI/TIA 603-C:2004 using an Agilent spectrum receiver with pre-selector. The bandwidth (RBW) of the spectrum receiver was 100 kHz up to 1 GHz and 1 MHz above 1 GHz with an appropriate sweep speed. The VBW above 1 GHz was 3 MHz. The analyzer was calibrated in dB above a micro volt at the output of the antenna.

RF POWER OUTPUT

Rule Part No.: FCC Part 2.1046(a), IC RSS-119 4.1 and 5.4, RSS-GEN 4.8

Test Requirements:

Method of Measurement: RF power is measured by connecting a 50-ohm, resistive wattmeter to the RF output connector. With a nominal battery voltage, and the transmitter properly adjusted the RF output measures:

Test Setup Diagram:

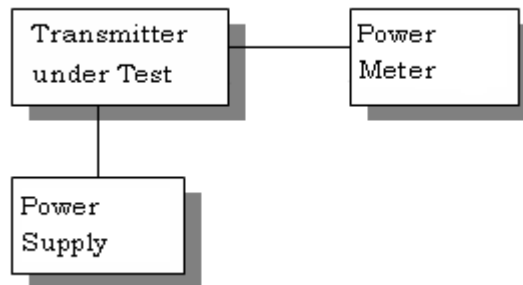

Test Data:

OUTPUT POWER (High): 48.7 dBm (75 Watts)
OUTPUT POWER (Low): 0.6 Watts

The power output is adjustable in 2 dB steps from 0.6 to 75 W.

Part 2.1033 (C)(8) DC Input into the final amplifier

INPUT POWER: $(26.4V)(12.8A) = 337.92$ Watts

Applicant: TELTRONIC, S.A.U
FCC ID: WT7PTRNKTBSR75410
IC CERT #: 8624A-PTRKT410
Report: T\TELTRONIC S.A.U\1963AT10\1963AT10TestReport.doc



MODULATION CHARACTERISTICS

Part 2.1033(c)

Part 2.1033(c) (4) Type of Emission: 20K0D7W, 20K0D7E, and 20K0D7D

FCC Part 90.209, IC RSS-119 5.5

FCC Part 90.207

The modulation is a $\pi/4$ DQPSK digital modulation scheme that in compasses both voice and data in the same transmission.

Applicant: TELTRONIC, S.A.U
FCC ID: WT7PTRNKTBSR75410
IC CERT #: 8624A-PTRKT410
Report: T\TELTRONIC S.A.U\1963AT10\1963AT10TestReport.doc



AUDIO FREQUENCY RESPONSE

Rule Part No.: FCC Part 2.1047(a)(b), IC RSS-119 5.2

Test Requirements:

Method of Measurement:

The audio frequency response was measured in accordance with ANSI/TIA 603-C:2004. A curve or equivalent data showing the frequency response of the audio modulating circuit over a range of 100 – 5000Hz shall be submitted. The audio frequency response curve is shown below.

AUDIO FREQUENCY RESPONSE PLOT

The audio is digitally encoded and as such the audio frequency response and modulation limiting data would be meaningless.

AUDIO INPUT VERSUS MODULATION

Rule Part No.: FCC Part 2.1047(b) & 90, IC RSS-119 5.2

Test Requirements:

Method of Measurement: **Modulation cannot exceed 100%**, The audio input level needed for a particular percentage of modulation was measured in accordance with ANSI/TIA 603-C:2004. The audio input curves versus modulation are shown below. Curves are provided for audio input frequencies of 300, 1000, and 2500 Hz.

Test data:

Applicant: TELTRONIC, S.A.U
FCC ID: WT7PTRNKTBSR75410
IC CERT #: 8624A-PTRKT410
Report: T\TELTRONIC S.A.U\1963AT10\1963AT10TestReport.doc

AUDIO LOW PASS FILTER

VOICE MODULATED COMMUNICATION EQUIPMENT

Part 2.1047(a) Voice modulated communication equipment: For equipment required to have an audio low-pass filter, a curve showing the frequency response of the filter, or of all the circuitry installed between the modulation limiter and the modulated stage shall be submitted.

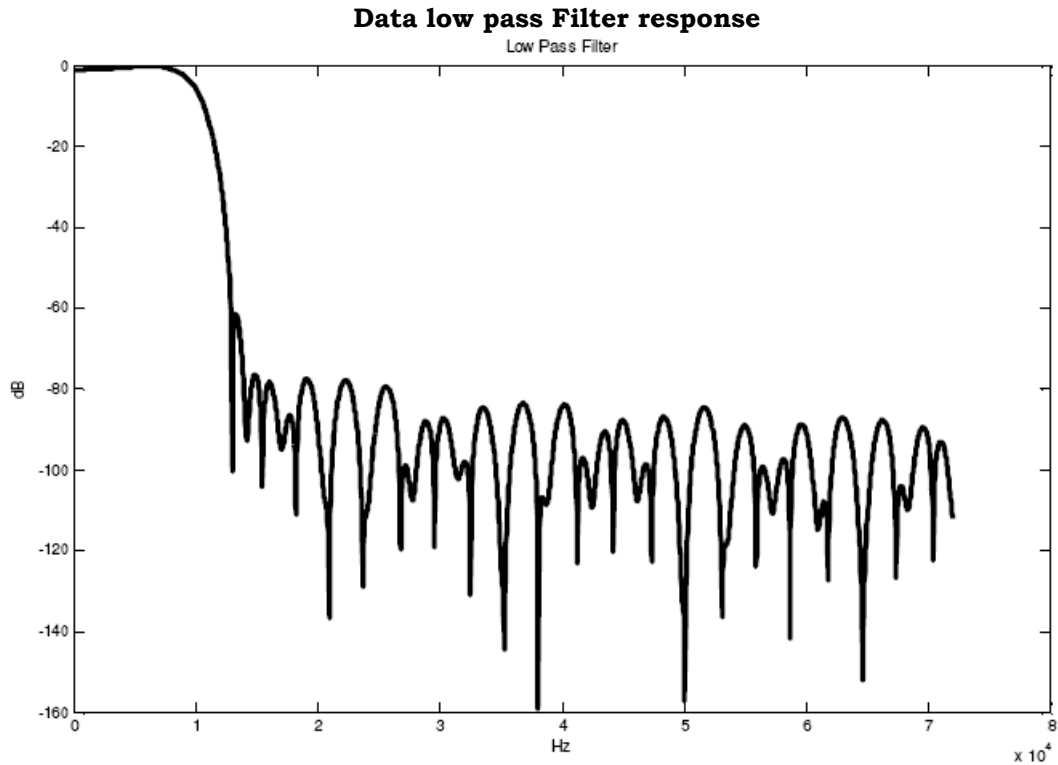

Applicant: TELTRONIC, S.A.U
 FCC ID: WT7PTRNKTBSR75410
 IC CERT #: 8624A-PTRKT410
 Report: T\TELTRONIC S.A.U\1963AT10\1963AT10TestReport.doc



OCCUPIED BANDWIDTH

FCC Part 2.1049(c), RSS-GEN 4.6 EMISSION BANDWIDTH

FCC Part 90.210(b) RSS-119 4.2 25kHz Channel Spacing with an audio low pass filter

Data in the plots show that on any frequency removed from the assigned frequency by more than 50%, but not more than 100%: At least 25dB. On any frequency removed from the assigned frequency by more than 100%, but not more than 250%: At least 35 dB. On any frequency removed from the assigned frequency by more than 250%, of the authorized bandwidth: At least $43 + 10\log(P)$ dB.

Part 90.210(c) 25 kHz Channel Spacing Not Equipped with a Low Pass Filter

For transmitters that are not equipped with an audio low pass filter pursuant to S90.211 (b), the power of any emission must be attenuated below the un-modulated carrier output power as follows; (1) On any frequency removed from the center of the authorized bandwidth by a displacement frequency (f_d in kHz) of more than 5 kHz but not more than 10 kHz: At least $83 \log(f_d/5)$ dB; (2) ON any frequency removed from the center of the authorized bandwidth by a displacement frequency (f_d in kHz) of more than 10 kHz, but not more than 250% of the authorized bandwidth: At least $29 \log(f_d^2/11)$ dB or 50 dB, whichever is the lesser attenuation; (3) On any frequency removed from the center of the authorized bandwidth by more than 250% of the authorized bandwidth: At least $43 + 10 \log(P_o)$ dB.

Applicant: TELTRONIC, S.A.U
FCC ID: WT7PTRNKTBSR75410
IC CERT #: 8624A-PTRKT410
Report: T\TELTRONIC S.A.U\1963AT10\1963AT10TestReport.doc

OCCUPIED BANDWIDTH

Rule Part No.: FCC Part 2.1049(c), RSS-GEN 4.6

Requirements:

FCC Part 90.210(b) RSS-119 4.2 25kHz Channel Spacing

Data in the plots show that on any frequency removed from the assigned frequency by more than 50%, but not more than 100%: At least 25dB. On any frequency removed from the assigned frequency by more than 100%, but not more than 250%: At least 35 dB. On any frequency removed from the assigned frequency by more than 250%, of the authorized bandwidth: At least $43 + 10\log(P)$ dB.

Part 90.210(c) Emission Mask C - 25 kHz Channel Spacing Not Equipped with an Audio Low Pass Filter

For transmitters that are not equipped with an audio low-pass filter, the power of any emission must be attenuated below the unmodulated carrier output power (P) as follows:

- (1) On any frequency removed from the center of the authorized bandwidth by a displacement frequency (f_d in kHz) of more than 5 kHz, but not more than 10 kHz: At least $83 \log(f_d/5)$ dB;
- (2) On any frequency removed from the center of the authorized bandwidth by a displacement frequency (f_d in kHz) of more than 10 kHz, but not more than 250 percent of the authorized bandwidth: At least $29 \log(f_d^2 / 11)$ dB or 50 dB, whichever is the lesser attenuation;
- (3) On any frequency removed from the center of the authorized bandwidth by more than 250 percent of the authorized bandwidth: At least $43 + 10 \log(P)$ dB.

Part 90.210(d) Emission Mask D - 12.5 kHz channel BW equipment.

For transmitters designed to operate with a 12.5 kHz channel bandwidth, any emission must be attenuated below the power (P) of the highest emission contained within the authorized bandwidth as follows:

- (1) On any frequency from the center of the authorized bandwidth f_0 to 5.625 kHz removed from f_0 : Zero dB.
- (2) On any frequency from the center of the authorized bandwidth by a displacement frequency (f_d in kHz) of more than 5.625 kHz but no more than 12.5 kHz: At least $7.27(f_d - 2.88 \text{ kHz})$ dB.
- (3) On any frequency removed from the center of the authorized bandwidth by a displacement frequency (f_d in kHz) of more than 12.5 kHz: At least $50 + 10\log(P)$ dB or 70 dB, whichever is the lesser attenuation.

Part 90.210(e) Emission Mask E - 6.25 kHz channel BW equipment.

For transmitters designed to operate with a 6.25 kHz bandwidth, any emission must be attenuated below the power (P) of the highest emission contained within the authorized bandwidth as follows:

- (1) On any frequency from the center of the authorized bandwidth f_0 to 3.0 kHz removed from f_0 : Zero dB.
- (2) On any frequency from the center of the authorized bandwidth by a displacement frequency (f_d in kHz) of more than 3.0 kHz but no more than 4.6 kHz: At least $30 + 16.67(f_d - 3.0 \text{ kHz})$ or $55 + 10 \log(P)$ or 65, whichever is the lesser attenuation.
- (3) On any frequency removed from the center of the authorized bandwidth by more than 4.6kHz: At least $55 + 10\log(P)$ dB or 65 dB, whichever is the lesser attenuation

Applicant: TELTRONIC, S.A.U
FCC ID: WT7PTRNKTBSR75410
IC CERT #: 8624A-PTRKT410
Report: T\TELTRONIC S.A.U\1963AT10\1963AT10TestReport.doc

OCCUPIED BANDWIDTH MEASUREMENT

Test procedure: ANSI/TIA-603-C:2004 para 2.2.11.

Test Setup Diagram:

OCCUPIED BANDWIDTH MEASUREMENT

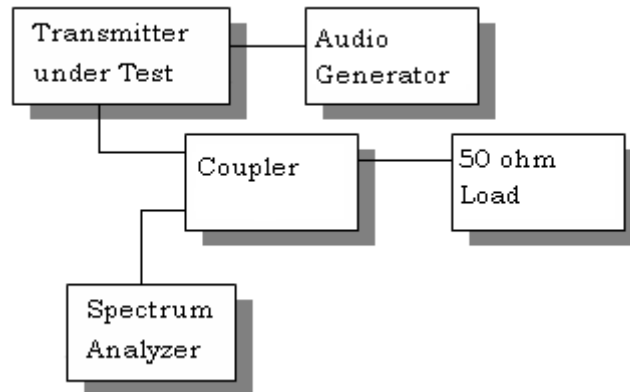

Test Data: See the plots below

25.0kHz – DIGITAL

NOTES:

FCC 90.210 Mask B

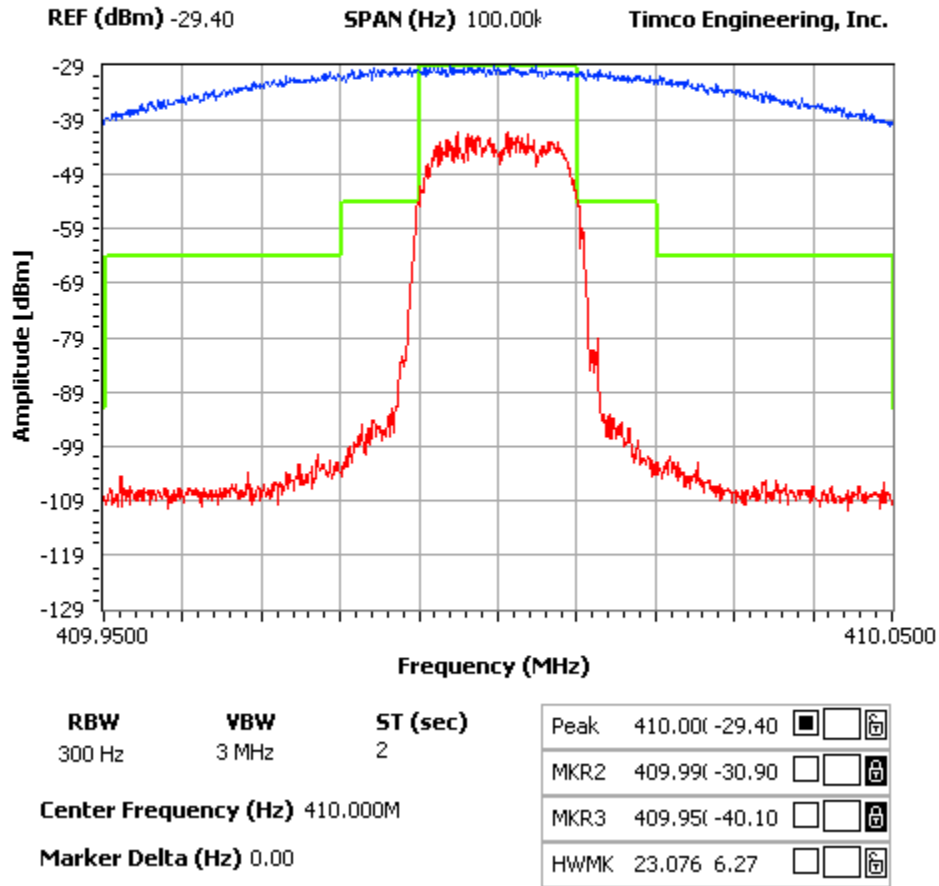

Applicant: TELTRONIC, S.A.U
 FCC ID: WT7PTRNKTBSR75410
 IC CERT #: 8624A-PTRKT410
 Report: T\TELTRONIC S.A.U\1963AT10\1963AT10TestReport.doc

SPURIOUS EMISSIONS AT ANTENNA TERMINALS (CONDUCTED)

Rule Part No.: FCC Part 2.1051(a), RSS-GEN 7.1.4

Requirements: 25 kHz Channel Spacing = 61.7dBc (for 75 Watts)

Method of Measurement: The carrier was modulated 100% using a 2500 Hz tone. The spectrum was scanned from 0.4 to at least the 10th harmonic of the fundamental. The measurements were made in accordance with standard ANSI/TIA 603-C:2004.

FCC Limit for:
 25 kHz Channel Spacing = 61.7
 12.5 kHz Spacing = 68.7

* no significant emissions

Test Data:

TF	EF	dB below carrier
409.00	818.00	89.1
	1227.00	87
	1636.00	87.9
	2045.00	88.6
	2454.00	89.8
	2863.00	92.5
	3272.00	*
	3681.00	*
	4090.00	*

TF	EF	dB below carrier
419.50	839.00	87.3
	1258.50	87.3
	1678.00	88.8
	2097.50	90.5
	2517.00	91.2
	2936.50	92.4
	3356.00	*
	3775.50	*
	4195.00	*

Applicant: TELTRONIC, S.A.U
 FCC ID: WT7PTRNKTBSR75410
 IC CERT #: 8624A-PTRKT410
 Report: T\TELTRONIC S.A.U\1963AT10\1963AT10TestReport.doc

TEST DATA CONTD.

TF	EF	dB below carrier
430.00	860.00	89.9
	1290.00	86.7
	1720.00	87.4
	2150.00	91.9
	2580.00	92.2
	3010.00	*
	3440.00	*
	3870.00	*
	4300.00	*

Applicant: TELTRONIC, S.A.U
FCC ID: WT7PTRNKTBSR75410
IC CERT #: 8624A-PTRKT410
Report: T\TELTRONIC S.A.U\1963AT10\1963AT10TestReport.doc

Method of Measuring Conducted Spurious Emissions

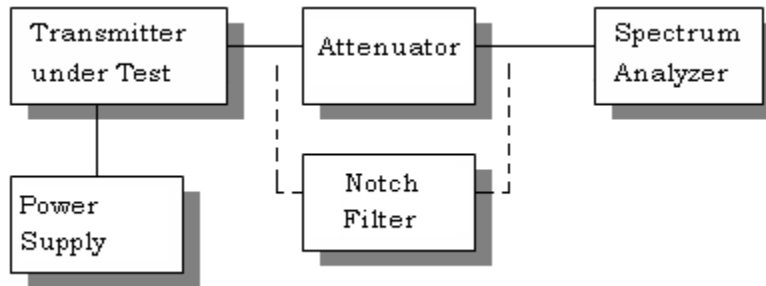

METHOD OF MEASUREMENT: The procedure used was ANSI/TIA 603-C:2004. The measurements were made at TIMCO ENGINEERING INC. 849 N.W. State Road 45, Newberry, Florida 32669.

Applicant: TELTRONIC, S.A.U
FCC ID: WT7PTRNKTBSR75410
IC CERT #: 8624A-PTRKT410
Report: T\TELTRONIC S.A.U\1963AT10\1963AT10TestReport.doc

FIELD STRENGTH OF SPURIOUS EMISSIONS

Rule Parts. No.: FCC Part 2.1053, RSS-GEN 4.9

Requirements: The FCC limits for radiated emissions are the same as previously stated for the conducted emissions.

METHOD OF MEASUREMENT: The tabulated data shows the results of the radiated field strength emissions test. The spectrum was scanned from 30 MHz to at least the tenth harmonic of the fundamental. This test was conducted per ANSI/TIA 603-C:2004 using the substitution method. Measurements were made at the test site of TIMCO ENGINEERING, INC. located at 849 NW State Road 45, Newberry, FL 32669.

Test Setup Diagram:

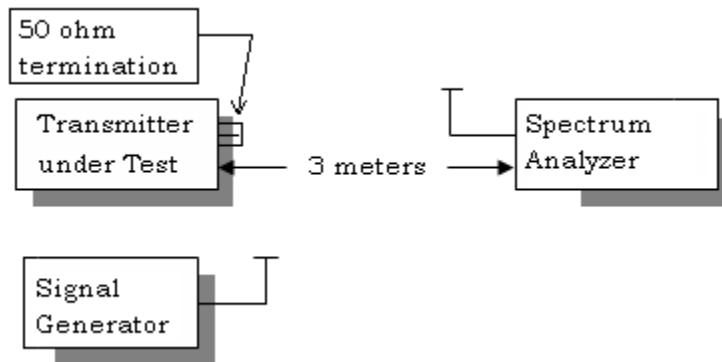

Test Data:

Emission Frequency MHz	Ant. Polarity	dB Below Carrier (dBc)
409.00	0	0
818.00	V	102.2
1227.00	V	106.7
1636.00	V	98.4
2045.00	V	99.1
2454.00	V	104.2
2863.00	V	86.6
3272.00	V	105.2
3681.00	V	104.3
4090.00	V	104.2

Emission Frequency MHz	Ant. Polarity	dB Below Carrier (dBc)
419.50	0	0
839.00	V	104.0
1258.50	V	105.2
1678.00	V	95.0
2097.50	V	110.2
2517.00	V	106.6
2936.50	V	87.1
3356.00	V	102.4
3775.50	V	103.4
4195.00	V	105.1

Emission Frequency MHz	Ant. Polarity	dB Below Carrier (dBc)
430.00	0	0
860.00	V	100.4
1290.00	V	104.6
1720.00	V	101.0
2150.00	V	106.3
2580.00	V	103.7
3010.00	V	104.3
3440.00	V	104.9
3870.00	V	103.5
4300.00	V	104.5

Applicant: TELTRONIC, S.A.U
 FCC ID: WT7PTRNKTBSR75410
 IC CERT #: 8624A-PTRKT410
 Report: T\TELTRONIC S.A.U\1963AT10\1963AT10TestReport.doc

RECEIVER RADIATED SPURIOUS EMISSIONS

Receiver data as shown below is not part of the FCC certification process. Per FCC Rules Part 15.101(b), the receiver is subject to verification.

The data shown below is part of the IC Certification process only.

Rule Parts. No.: RSS-GEN 4.10, 6

Requirements:

Frequency MHz	Limits
30 – 88	40.0 dBμV/m measured @ 3 meters
88 – 216	43.5 dBμV/m measured @ 3 meters
216 – 960	46.0 dBμV/m measured @ 3 meters
Above 960	54.0 dBμV/m measured @ 3 meters

TEST DATA:

Tuned Frequency MHz	Emission Frequency MHz	Meter Reading dBuV	Ant. Polarity	Coax Loss dB	Correction Factor dB/m	Field Strength dBuV/m	Margin dB
419.5	48.00	22.7	H	0.49	12.12	35.31	4.69
419.5	48.00	26.7	V	0.49	11.20	38.39	1.61
419.5	72.20	26.6	H	0.57	5.87	33.04	6.96
419.5	72.50	27.8	V	0.58	6.35	34.73	5.28
419.5	96.30	27.2	H	0.64	10.63	38.47	5.03
419.5	96.30	30.5	V	0.64	11.50	42.64	0.86
419.5	120.40	22.7	H	0.67	10.58	33.95	9.55
419.5	120.40	26.2	V	0.67	11.19	38.06	5.44
419.5	160.40	21.4	V	0.74	16.97	39.11	4.39
419.5	160.60	23.5	H	0.74	16.38	40.62	2.88
419.5	195.40	19.1	V	0.88	16.02	36.00	7.50
419.5	195.40	25.2	H	0.88	15.51	41.59	1.91
419.5	230.00	20.5	V	0.96	11.20	32.66	13.34
419.5	240.00	20.8	H	0.98	12.00	33.78	12.22
419.5	288.00	22.2	H	1.08	13.96	37.24	8.76
419.5	305.60	23.3	V	1.11	14.79	39.20	6.80
419.5	320.00	28.3	H	1.12	15.00	44.42	1.58
419.5	320.00	29.9	V	1.12	14.70	45.72	0.28
419.5	350.40	19.3	H	1.15	15.00	35.45	10.55

Applicant: TELTRONIC, S.A.U
 FCC ID: WT7PTRNKTBSR75410
 IC CERT #: 8624A-PTRKT410
 Report: T\TELTRONIC S.A.U\1963AT10\1963AT10TestReport.doc

TEST DATA CONTD.

Tuned Frequency MHz	Emission Frequency MHz	Meter Reading dBuV	Ant. Pol	Coax Loss dB	Correction Factor dB/m	Field Strength dBuV/m	Margin dB
419.5	384.00	22.5	H	1.18	15.56	39.24	6.76
419.5	399.60	22.6	V	1.20	15.70	39.50	6.50
419.5	400.00	23.4	H	1.20	16.10	40.70	5.30
419.5	432.80	15.7	H	1.23	16.58	33.51	12.49
419.5	480.40	14.2	H	1.28	17.69	33.17	12.83
419.5	540.00	15.4	V	1.42	18.10	34.92	11.08
419.5	691.20	12.4	H	1.69	21.00	35.09	10.91
419.5	736.00	13.0	V	1.77	20.76	35.53	10.47
419.5	816.00	11.4	H	1.91	21.82	35.13	10.87
419.5	900.00	13.5	V	1.95	22.70	38.15	7.85

Applicant: TELTRONIC, S.A.U
 FCC ID: WT7PTRNKTBSR75410
 IC CERT #: 8624A-PTRKT410
 Report: T\TELTRONIC S.A.U\1963AT10\1963AT10TestReport.doc

FREQUENCY STABILITY

Rule Parts. No.: FCC Part 2.1055, Part 90.213, RSS-119 5.3, RSS-GEN 7.2.4

Requirements: Temperature range requirements: -30 to +50° C.
Voltage Variation +, -15%
±1.5 PPM

Method of Measurements: ANSI/TIA 603-C:2004

Test Data:

Assigned Frequency (Ref. Frequency) (MHz)		420.000054
Temperature (°C)	Frequency (MHz)	Frequency Stability (PPM)
-30	420.000048	-0.01
-20	420.000049	-0.01
-10	420.000049	-0.01
0	420.000049	-0.01
+10	420.000048	-0.01
+20	420.000048	-0.01
+30	420.000048	-0.01
+40	420.000049	-0.01
+50	420.000049	-0.01

Assigned Frequency (Ref. Frequency) (MHz)		
% Battery (%)	Frequency (MHz)	Frequency Stability (PPM)
-15%	420.000051	-0.01
	420.000054	0.00
+15%	420.000055	0.00

TRANSIENT FREQUENCY BEHAVIOR

FCC Part 2.1055(a)(1)

FCC Part 90.214, IC RSS-119 5.8

REQUIREMENTS: Transmitters designed to operate in the 150-174 MHz and 421-512 MHz frequency bands must maintain transient frequencies within the maximum transient frequencies within the maximum frequency difference limits during the time intervals indicated:

Time Intervals	Maximum frequency difference	All Equipment	
		150-174 MHz	421-512 MHz

Transient Frequency Behavior for Equipment Designed to Operate on 25 kHz Channels

Time Intervals	Maximum frequency difference	150-174 MHz	421-512 MHz
t ₁ ⁴	±25.0 kHz	5.0 ms	10.0 ms
t ₂	±12.5 kHz	20.0 ms	25.0 ms
t ₃ ⁴	±25.0 kHz	5.0 ms	10.0 ms

Transient Frequency Behavior for Equipment Designed to Operate on 12.5 kHz Channels

Time Intervals	Maximum frequency difference	150-174 MHz	421-512 MHz
t ₁ ⁴	±12.5 kHz	5.0 ms	10.0 ms
t ₂	±6.25 kHz	20.0 ms	25.0 ms
t ₃ ⁴	±12.5 kHz	5.0 ms	10.0 ms

Transient Frequency Behavior for Equipment Designed to Operate on 6.25 kHz Channels

Time Intervals	Maximum frequency difference	150-174 MHz	421-512 MHz
t ₁ ⁴	±6.25 kHz	5.0 ms	10.0 ms
t ₂	±3.125 kHz	20.0 ms	25.0 ms
t ₃ ⁴	±6.25 kHz	5.0 ms	10.0 ms

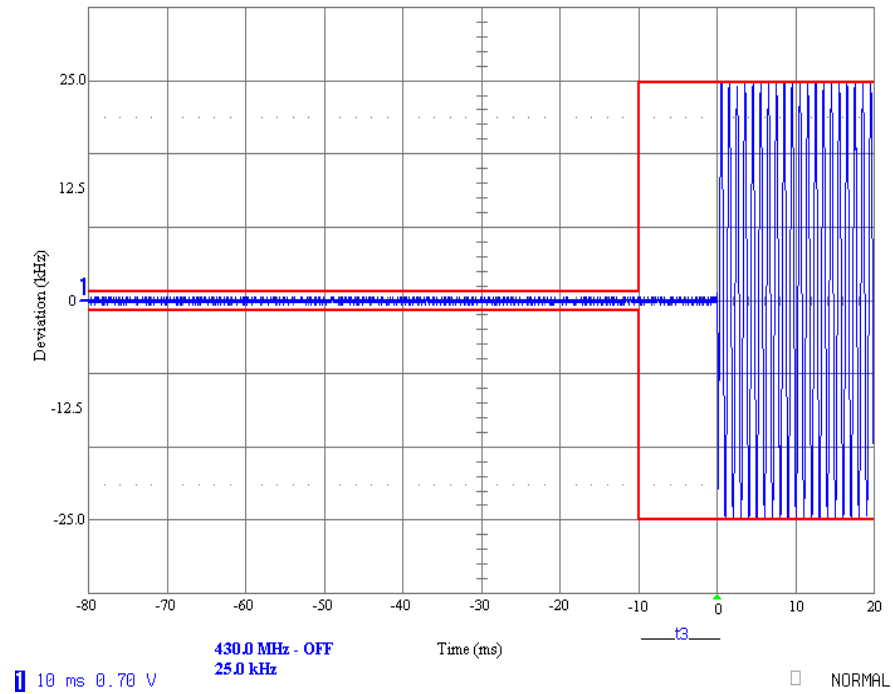
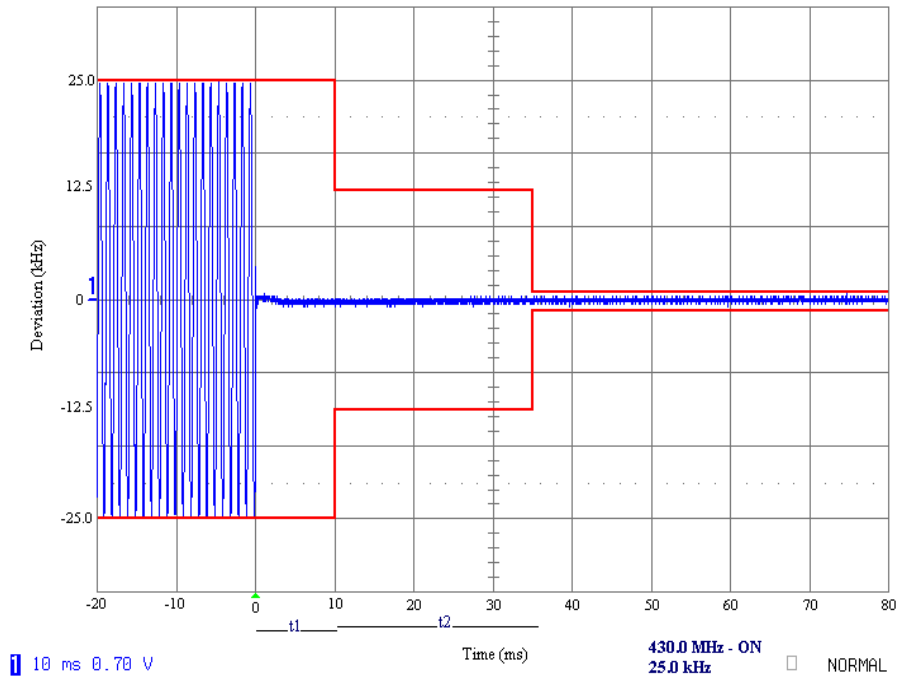

Applicant: TELTRONIC, S.A.U
 FCC ID: WT7PTRNKTBSR75410
 IC CERT #: 8624A-PTRKT410
 Report: T\TELTRONIC S.A.U\1963AT10\1963AT10TestReport.doc

TEST PROCEDURE: ANSI/TIA 603-C:2004 PARA 2.2.19

1. Using the variable attenuator the transmitter level was set to 40 dB below the test receivers maximum input level, then the transmitter was turned off.
2. With the transmitter off the signal generator was set 20dB below the level of the transmitter in the above step, this level will be maintained with the signal generator through-out the test.
3. Reduce the attenuation between the transmitter and the RF detector by 30 dB. With the levels set as above the transient frequency behavior was observed & recorded.

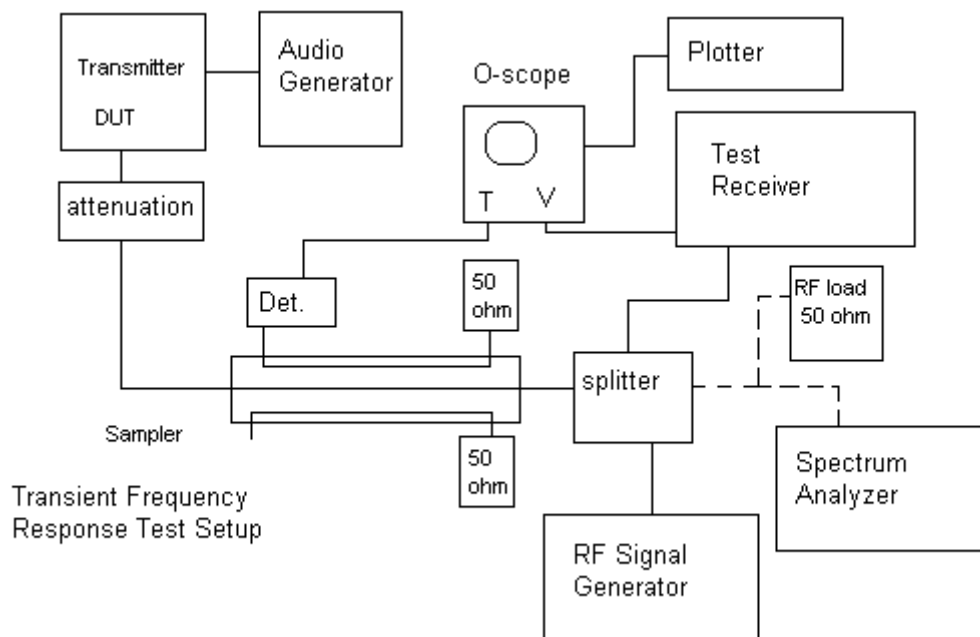

EMC EQUIPMENT LIST

Device	Manufacturer	Model	Serial Number	Cal/Char Date	Due Date
3-Meter Semi-Anechoic Chamber	Panashield	N/A	N/A	Listed 3/10/10	3/10/12
AC Voltmeter	HP	400FL	2213A14499	CAL 3/23/09	3/23/11
Antenna: Dipole Kit	Electro-Metrics	TDA-30/1-4	153	CHAR 6/10/09	6/10/11
Frequency Counter	HP	5385A	3242A07460	CAL 5/26/09	5/26/11
Hygro-Thermometer	Extech	445703	0602	CAL 1/30/09	1/30/11
Modulation Analyzer	HP	8901A	3435A06868	CAL 5/26/09	5/26/11
Digital Multimeter	Fluke	FLUKE-77-3	79510405	CAL 5/18/09	5/18/11
Analyzer Tan Tower Preamplifier	HP	8449B-H02	3008A00372	CAL 11/21/09	11/21/11
Analyzer Tan Tower Quasi-Peak Adapter	HP	85650A	3303A01690	CAL 11/22/09	11/22/11
Analyzer Tan Tower RF Preselector	HP	85685A	3221A01400	CAL 11/21/09	11/21/11
Analyzer Tan Tower Spectrum Analyzer	HP	8566B Opt 462	3138A07786 3144A20661	CAL 11/24/09	11/24/11
Temperature Chamber	Tenney Engineering	TTRC	11717-7	CHAR 4/25/10	4/25/12

Applicant: TELTRONIC, S.A.U
 FCC ID: WT7PTRNKTBSR75410
 IC CERT #: 8624A-PTRKT410
 Report: T\TELTRONIC S.A.U\1963AT10\1963AT10TestReport.doc