

FCC PART 90
IC RSS-119, ISSUE 10, APRIL 2010
IC RSS-310, ISSUE 2, JULY 2007
TEST AND MEASUREMENT REPORT
For
Teltronic S.A.U.

Poligono Malpica, Calle F Oeste,
50057 Zaragoza, Spain

FCC ID: WT7PTRKTMDT400410
IC: 8624A-PTMDT410
Model: MDT-400 409-430MHz

Report Type: Original Report	Product Type: Land-Mobile and Fixed Radio Transmitter and Receiver
Test Engineer: Jerry Huang	<i>Jerry Huang</i>
Report Number: R1011081-90	
Report Date: 2010-11-23	
Reviewed By: Victor Zhang RF Lead	<i>Victor Zhang</i>
Prepared By: (84)	Bay Area Compliance Laboratories Corp. 1274 Anvilwood Avenue, Sunnyvale, CA 94085, U.S.A. Tel: (408) 732-9162 Fax: (408) 732 9164 www.baclcorp.com

Note: This test report is prepared for the customer shown above and for the device described herein. It may not be duplicated or used in part without prior written consent from Bay Area Compliance Laboratories Corp. This report **must not** be used by the customer to claim product certification, approval, or endorsement by NVLAP*, NIST, or any agency of the Federal Government.

* This report may contain data that are not covered by the NVLAP accreditation and are marked with an asterisk "*" 8000

TABLE OF CONTENTS

1. General Information.....	5
1.1 PRODUCT DESCRIPTION FOR EQUIPMENT UNDER TEST (EUT).....	5
1.2 MECHANICAL DESCRIPTION	5
1.3 OBJECTIVE.....	5
1.4 RELATED SUBMITTAL(S)/GRANT(S)	5
1.5 TEST METHODOLOGY	6
1.6 MEASUREMENT UNCERTAINTY	6
1.7 TEST FACILITY	6
2 System Test Configuration.....	7
2.1 JUSTIFICATION.....	7
2.2 EQUIPMENT MODIFICATIONS	7
2.3 LOCAL SUPPORT EQUIPMENT	7
2.4 INTERNAL CONFIGURATION.....	7
2.5 LOCAL SUPPORT EQUIPMENT POWER SUPPLY AND LINE FILTERS	7
2.6 INTERFACE PORTS AND CABLING	7
2.7 TEST SETUP BLOCK DIAGRAM.....	8
3 Summary of Test Results	9
4 FCC §2.1091 & IC RSS-102 - RF Exposure Information	10
4.1 APPLICABLE STANDARDS	10
5 FCC §2.1046, §90.205 & IC RSS-119 §5.4 – Conducted Output Power	13
5.1 APPLICABLE STANDARD.....	13
5.2 TEST PROCEDURE	13
5.3 TEST ENVIRONMENTAL CONDITIONS.....	13
5.4 TEST EQUIPMENT LIST AND DETAILS	13
5.5 TEST RESULTS	14
6 FCC §2.1047, §90.207 & IC RSS-119 §5.2 – Modulation Characteristic.....	15
6.1 APPLICABLE STANDARD.....	15
6.2 TEST PROCEDURE	15
6.3 TEST RESULT.....	15
7 FCC §2.1049, §90.209, §90.210 & IC RSS-119 §5.5– Occupied Bandwidth & Emission Mask.....	17
7.1 APPLICABLE STANDARD.....	17
7.2 TEST PROCEDURE	18
7.3 TEST ENVIRONMENTAL CONDITIONS.....	18
7.4 TEST EQUIPMENT LIST AND DETAILS	18
7.5 TEST RESULTS	18
8 FCC §2.1051, §90.210 & IC RSS-119 §5.8 - Spurious Emissions at Antenna Terminals	21
8.1 APPLICABLE STANDARD.....	21
8.2 TEST PROCEDURE	21
8.3 TEST ENVIRONMENTAL CONDITIONS.....	21
8.4 TEST EQUIPMENT LIST AND DETAILS	21
8.5 TEST RESULTS	21
9 FCC §2.1055 (d), §90.213 & IC RSS-119 §5.3- Frequency Stability	23
9.1 APPLICABLE STANDARD.....	23
9.2 TEST PROCEDURE	24
9.3 TEST ENVIRONMENTAL CONDITIONS.....	25

9.4	TEST EQUIPMENT LIST AND DETAILS	25
9.5	TEST RESULT	25
10	FCC §2.1053, §90.210 & IC RSS-119 §5.8 – Field Strength of Spurious Radiation	26
10.1	APPLICABLE STANDARD	26
10.2	TEST PROCEDURE	26
10.3	TEST ENVIRONMENTAL CONDITIONS.....	26
10.4	TEST EQUIPMENT LIST AND DETAILS	27
10.5	TEST RESULTS	27
11	FCC §90.214 & IC RSS-119 §5.9 - Transient Frequency Behavior	28
11.1	APPLICABLE STANDARD	28
11.2	TEST PROCEDURE	29
11.3	TEST ENVIRONMENTAL CONDITIONS.....	29
11.4	TEST EQUIPMENT LIST AND DETAILS	29
11.5	TEST RESULTS	29
11.6	TEST SETUP BLOCK DIAGRAM.....	29
12	IC RSS-119 §5.11 & IC RSS-310 §3.1 Receiver Spurious Radiated Emissions.....	31
12.1	APPLICABLE STANDARD	31
12.2	TEST BLOCK DIAGRAM.....	31
12.3	TEST EQUIPMENT LISTS AND DETAILS.....	32
12.4	TEST ENVIRONMENTAL CONDITIONS.....	33
12.5	TEST PROCEDURE	33
12.6	CORRECTED AMPLITUDE & MARGIN CALCULATION	33
12.7	SUMMARY OF TEST RESULTS.....	33
12.8	RADIATED SPURIOUS EMISSIONS PLOT & DATA.....	35
13	EXHIBIT A - FCC ID & IC Labeling Requirements.....	37
13.1	FCC ID LABEL REQUIREMENT	37
13.2	IC LABELING REQUIREMENTS	37
13.3	FCC AND IC LABEL CONTENT.....	38
13.4	FCC ID AND IC LABEL LOCATION ON EUT	38
14	EXHIBIT B - Test Setup Photographs	39
14.1	BELOW 1 GHZ RADIATED EMISSION – FRONT VIEW	39
14.2	BELOW 1 GHZ RADIATED EMISSION – REAR VIEW	39
14.3	ABOVE 1 GHZ RADIATED EMISSION – FRONT VIEW.....	40
14.4	ABOVE 1 GHZ RADIATED EMISSION – REAR VIEW	40
14.5	BENCH TEST - FRONT VIEW.....	41
14.6	RECEIVING SPURIOUS EMISSION 30 MHz TO 1 GHz - FRONT VIEW	41
14.7	RECEIVING SPURIOUS EMISSION 30 MHz TO 1 GHz - REAR VIEW.....	42
14.8	RECEIVING SPURIOUS EMISSION ABOVE 1 GHz - FRONT VIEW	42
14.9	RECEIVING SPURIOUS EMISSION ABOVE 1 GHz - REAR VIEW	43
14.10	GPS RECEIVER SPURIOUS EMISSION - FRONT VIEW	43
14.11	GPS RECEIVER SPURIOUS EMISSION 30 MHz TO 1 GHz - REAR VIEW	44
14.12	GPS RECEIVER SPURIOUS EMISSION ABOVE 1 GHz - REAR VIEW	44
15	EXHIBIT C - EUT Photographs.....	45
15.1	EUT - FRONT VIEW	45
15.2	EUT – REAR VIEW	45
15.3	EUT – TOP VIEW.....	46
15.4	EUT – BOTTOM VIEW	46
15.5	EUT- RADIO BOARD – UPPER SIDE VIEW	47
15.6	EUT- RADIO BOARD – LOWER SIDE VIEW	47
15.7	EUT-CONTROL AND GPS BOARD – UPPER SIDE VIEW.....	48
15.8	EUT- CONTROL AND GPS BOARD – LOWER SIDE VIEW	48

DOCUMENT REVISION HISTORY

Revision Number	Report Number	Description of Revision	Date of Revision
0	R1011081-90	Original Report	2010-11-23

1. General Information

1.1 Product Description for Equipment under Test (EUT)

The report has been prepared on behalf of Teltronic S.A.U. and their product FCC ID: WT7PTRKTMDT400410, IC: 8624A-PTMDT410, model: MDT-400 409 ~ 430 MHz or the EUT as referred to in the rest of this report. The EUT is a Land-Mobile and Fixed Radio Transmitter and Receiver and Receiver with GPS receiver.

The EUT is a 409~430 MHz Transceiver that operates under FCC Part 90 and IC RSS-119

Specifications	
Frequency Band	409~430 MHz
Emission designator	20K0D7E, 20K0D7D, 20K0D7W, 20K0Q7E, 20K0Q7D, 20K0Q7W.
Modulation	$\pi/4$ -DQPSK TDMA 4 slots
RF Output Power	6 Watts
RF Channel Spacing	25 kHz (Spectrum Efficiency 6.25 kHz) ^{Note 1}
Necessary / authorized Bandwidth	20 kHz
Power Supply	10.8~15.6 DC volt supply input

Note 1:

“TETRA access scheme is TDMA with 4 physical channels per carrier. The channel bandwidth is 25 kHz. As a result, the equipment meets a spectrum efficiency standard of one voice channel per 6.25 kHz of channel bandwidth. Modulation is $\pi/4$ -DQPSK with 18Ksym/sec. This modulation is based on transmitting two bits per symbol, so the data rate on each sub-carrier is 9000 bits/sec (higher than 4800 bits per second per 6.25 kHz of channel bandwidth).”

1.2 Mechanical Description

The EUT measures approximately 21cm (L) x 16cm (W) x 5cm (H) and weighs 1675.5 g.

The test data gathered are from production sample. Serial number: R1010281-1 provided by the BACL.

1.3 Objective

This Type approval report is prepared on behalf of *Teltronic S.A.U.* in accordance with Part 90 of the Federal Communication Commissions rules, Industry Canada RSS-119 Issue 10, April 2010 and Industry Canada RSS-310 Issue 2, July 2007.

1.4 Related Submittal(s)/Grant(s)

None.

1.5 Test Methodology

All tests and measurements indicated in this document were performed in accordance with the Code of federal Regulations Title 47 Part 2, Sub-part J as well as the following individual parts:

Part 90 – Private Land Mobile Radio Service

And IC RSS-119, Issue 10, April 2010- Land Mobile and Fixed Radio Transmitters and Receivers Operating in the Frequency Range 27.41-960 MHz with IC RSS-Gen, Issue 2, June 2007 – General Requirements and Information for the Certification of Radiocommunication Equipment

Applicable Standards: TIA603-C and ANSI 63.4-2003, American National Standard for Method of Measurement of Radio-Noise Emissions from Low-Voltage Electrical and Electronic Equipment in the range of 9 kHz to 40 GHz.

All emissions measurement was performed by Bay Area Compliance Laboratories Corp. The radiated testing was performed at an antenna-to-EUT distance of 3 meters.

1.6 Measurement Uncertainty

All measurements involve certain levels of uncertainties, especially in the field of EMC. The factors contributing to uncertainties are spectrum analyzer, cable loss, antenna factor calibration, antenna directivity, antenna factor variation with height, antenna phase center variation, antenna factor frequency interpolation, measurement distance variation, site imperfections, mismatch (average), and system repeatability.

Based on NIS 81, The Treatment of Uncertainty in EMC Measurements, the values ranging from ± 2.0 dB for Conducted Emissions tests and ± 4.0 dB for Radiated Emissions tests are the most accurate estimates pertaining to uncertainty of EMC measurements at BACL Corp.

Detailed instrumentation measurement uncertainties can be found in BACL Corp. report QAP-018.

1.7 Test Facility

The test site used by BACL Corp. to collect radiated and conducted emissions measurement data is located at its facility in Sunnyvale, California, USA.

The test sites at BACL have been fully described in reports submitted to the Federal Communication Commission (FCC) and Voluntary Control Council for Interference (VCCI). The details of these reports has been found to be in compliance with the requirements of Section 2.948 of the FCC Rules on February 11 and December 10, 1997 and Article 8 of the VCCI regulations on December 25, 1997. The facility also complies with the radiated and AC line conducted test site criteria set forth in ANSI C63.4-2003.

The Federal Communications Commission, Industry Canada, and Voluntary Control Council for Interference has the reports on file and is listed under FCC registration number: 90464, IC registration number: 3062A, and VCCI Registration Number: C-2463 and R-2698. The test site has been approved by the FCC, IC, and VCCI for public use and is listed in the FCC Public Access Link (PAL) database.

Additionally, BACL is a National Institute of Standards and Technology (NIST) accredited laboratory, under the National Voluntary Laboratory Accredited Program (Lab Code 200167-0). The current scope of accreditations can be found at <http://ts.nist.gov/ts/htdocs/210/214/scopes/2001670.htm>

2 System Test Configuration

2.1 Justification

The EUT was configured for testing according to TIA/EIA-603-C.

The EUT was tested in the normal (native) operating mode to represent *worst*-case results during the final qualification test.

2.2 Equipment Modifications

No modifications were made to the EUT.

2.3 Local Support Equipment

Manufacturer	Description	Model No.	Serial No.
Dell	Laptop	Inspiron 300m	-

2.4 Internal Configuration

Manufacturer	Description	Model No.	Serial No.
Teltronic S.A.U.	Control Board	F054001	-
Teltronic S.A.U.	Radio Board	F054002	-
Teltronic S.A.U.	GPS Board	F054203	-

2.5 Local Support Equipment Power Supply and Line Filters

Manufacturer	Description	Model	Serial Number
BK PRECISION	DC power supply	1612A	D185052265

2.6 Interface Ports and Cabling

Cable Description	Length (m)	From	To
Serial cable	>1.0	Laptop Serial port	EUT Serial Port

2.7 Test Setup Block Diagram

Radiated Test

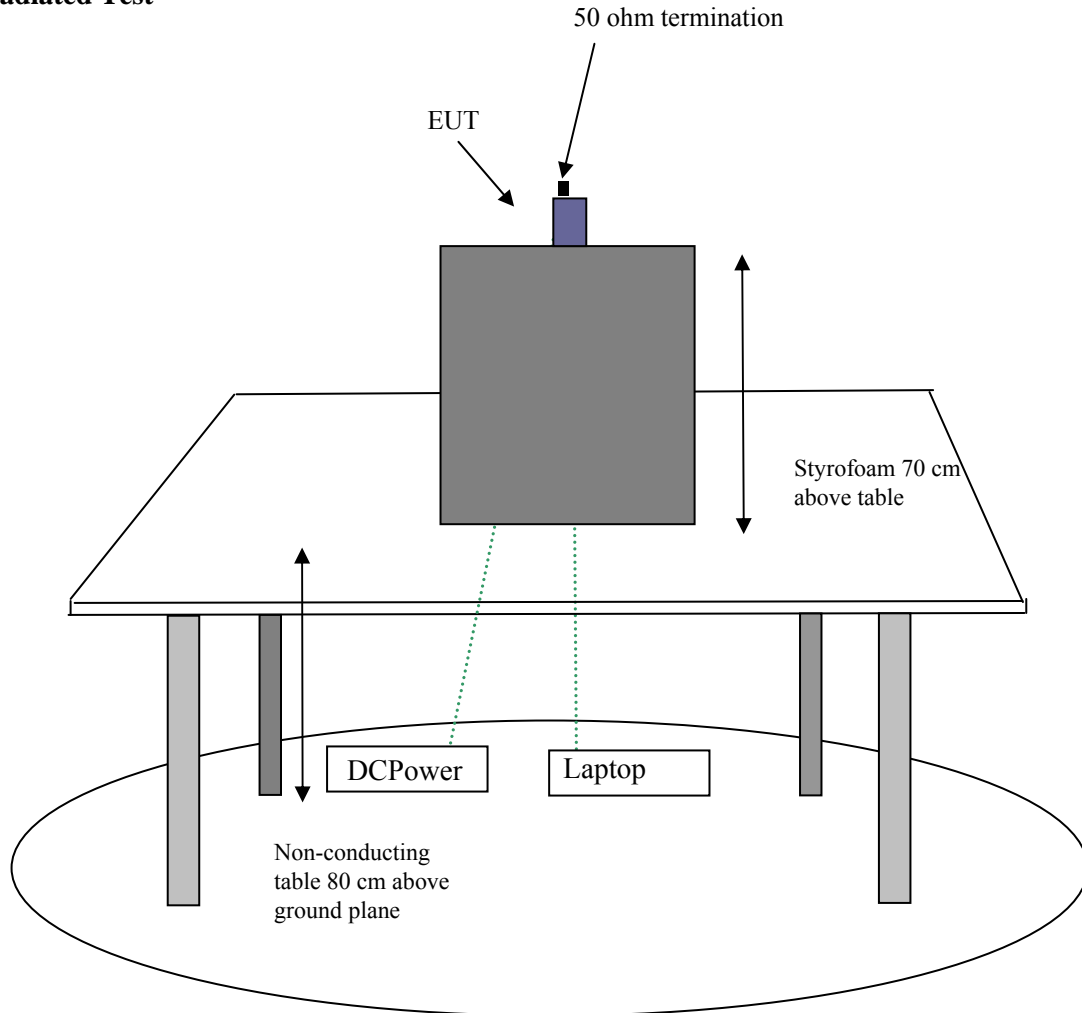

Conducted Test

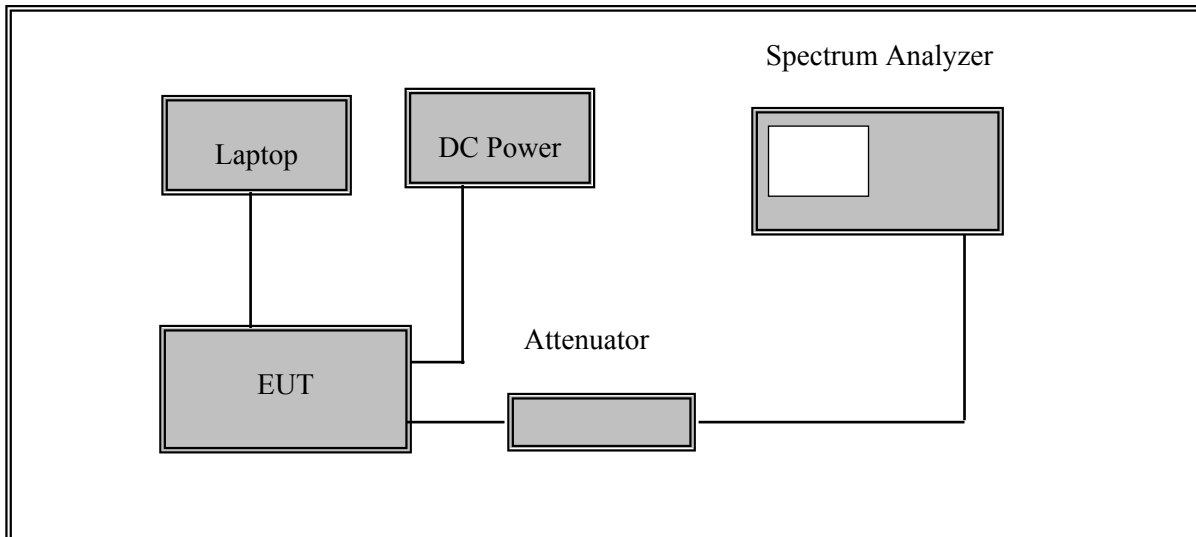

3 Summary of Test Results

FCC and IC Rules	Description of Test	Result
FCC§1.1310, §2.1091 IC RSS-102	RF Exposure	Compliant
FCC§2.1046, §90.205 IC RSS-119 §5.4	RF Output Power	Compliant
FCC§2.1047, §90.207 IC RSS-119 §5.2	Modulation Characteristics, Audio Frequency Response and Audio Filter Response	Compliant
FCC §2.1049, §90.210 IC RSS-119 §5.5	Occupied Bandwidth and Emission Mask	Compliant
FCC §2.1051, §90.210 IC RSS-119 §5.8	Spurious Emissions at Antenna Terminals	Compliant
FCC §2.1055, §90.213 IC RSS-119 §5.3	Frequency stability	Compliant
FCC §2.1053, §90.210 IC RSS-119 §5.8	Field strength of spurious radiation	Compliant
FCC §90.214 IC RSS-119 §5.9	Transient Frequency Behavior	Compliant
IC RSS-119 §5.11 RSS-310 §3.1	Receiver Spurious Emission	Compliant

4 FCC §2.1091 & IC RSS-102 - RF Exposure Information

4.1 Applicable Standards

FCC §2.1091

(a) Requirements of this section are a consequence of Commission responsibilities under the National Environmental Policy Act to evaluate the environmental significance of its actions. See subpart I of part 1 of this chapter, in particular §1.1307(b).

According to §1.1310 and §2.1091 RF exposure is calculated.

Limits for Exposure

Frequency Range (MHz)	Electric Field Strength (V/m)	Magnetic Field Strength (A/m)	Power Density (mW/cm ²)	Averaging Time (minutes)
(A) Limits for Occupational/Controlled Exposures				
0.3-3.0	614	1.63	*(100)	6
3.0-30	1842/f	4.89/f	*(900/f ²)	6
30-300	61.4	0.163	1.0	6
300-1500	/	/	f/300	6
1500-100,000	/	/	1	6
(B) Limits for General Population/Uncontrolled Exposure				
0.3-1.34	614	1.63	*(100)	30
1.34-30	842/f	2.19/f	*(180/f ²)	30
30-300	27.5	0.073	0.2	30
300-1500	/	/	f/150	30
1500-100,000	/	/	1	30

f = frequency in MHz

* = Plane-wave equivalent power density

Note 1 to Table 1: Occupational/controlled limits apply in situations in which persons are exposed as a consequence of their employment provided those persons are fully aware of the potential for exposure and can exercise control over their exposure. Limits for occupational/controlled exposure also apply in situations when an individual is transient through a location where occupational/controlled limits apply provided he or she is made aware of the potential for exposure.

Note 2 to Table 1: General population/uncontrolled exposures apply in situations in which the general public may be exposed, or in which persons that are exposed as a consequence of their employment may not be fully aware of the potential for exposure or can not exercise control over their exposure.

According to IC RSS-102 Issue 2 section 4.4, RF Field Strength Limits for Controlled Use Devices (Controlled Environment).

Frequency Range (MHz)	Electric Field (V/m rms)	Magnetic Field (A/m rms)	Power Density (W/m ²)	Time Averaging (min)
0.003 - 1	600	2.19	-	6
1 - 10	600 / f	4.9 / f	-	6
10 - 30	60	4.9 / f	-	6
30 – 300	60	0.163	10*	6
300 – 1 500	3.54 f ^{0.5}	0.0094f ^{0.5}	f/30	6
1 500 – 15 000	137	0.364	50	6
15 000 – 150 000	137	0.364	50	616000 / f ^{1.2}
150 000- 300 000	0.354f ^{0.5}	9.4 x10 ⁻⁴ f ^{0.5}	3.33 x 10 ⁻⁴ f	616000 / f ^{1.2}

Note: f is frequency in MHz

* = Power density limit is applicable at frequencies greater than 100 MHz

Antenna

The manufacturer does not specify an antenna. This device has provisions for operation in a vehicle, or a fixed location

MPE Prediction

Predication of MPE limit at a given distance, Equation from OET Bulletin 65, Edition 97-01

$$S = PG/4\pi R^2$$

Where: S = power density

P = power input to antenna

G = power gain of the antenna in the direction of interest relative to an isotropic radiator

R = distance to the center of radiation of the antenna

Duty Cycle (TDMA 4slots)	<u>25%</u>
Maximum peak output power at antenna input terminal (dBm):	<u>38.31</u>
Maximum peak output power at antenna input terminal (mW):	<u>6776.415</u>
Prediction distance (cm):	<u>25</u>
Prediction frequency (MHz):	<u>415</u>
Maximum Antenna Gain, typical (dBi):	<u>8</u>
Maximum Antenna Gain (numeric):	<u>6.310</u>
Power density of prediction frequency at 25 cm (W/m ²):	<u>13.61</u>
Power density of prediction frequency at 25 cm (mW/cm ²):	<u>1.361</u>
MPE limit for uncontrolled exposure at prediction frequency (W/m ²):	<u>13.83</u>
MPE limit for uncontrolled exposure at prediction frequency (mW/cm ²):	<u>1.383</u>

Conclusion

The device complies with the MPE requirements by providing a safe separation distance of at least 25 cm between the antenna with maximum 8dBi gain, including any radiating structure, and any persons when normally operated .

Proposed RF exposure safety information to include in User's Manual:**“FCC RF Exposure Requirements”:****CAUTION:**

The antenna(s) used for this transmitter must not be co-located or operating in conjunction with any other antenna or transmitter.:

- Antennas used for this transmitter must not exceed an antenna gain of 8 dBi
- For rear deck trunk and roof top installations, the antenna must be located at least 25 cm away from rear-seat passengers and bystanders in order to comply with the FCC RF exposure requirements.

The following label will be mounted in conspicuous view on the radio.

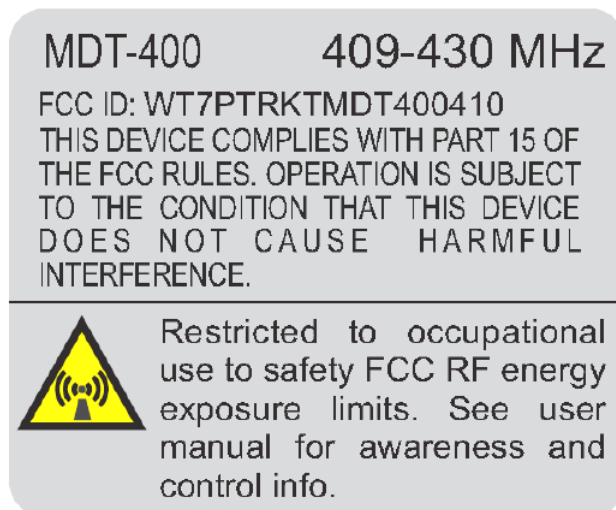

5 FCC §2.1046, §90.205 & IC RSS-119 §5.4 – Conducted Output Power

5.1 Applicable Standard

According to FCC §2.1046, and §90.205, 421-430 MHz Power and height limitations are specified in §90.279

According to IC RSS-119 §5.4, the output power should be within ± 1.0 dB of the manufacture's rated power.

5.2 Test Procedure

The RF output of the transmitter was connected to the input of the spectrum analyzer through sufficient attenuation.

Spectrum Analyzer Setting:

<u>RBW</u>	<u>Video BW</u>
100 kHz	300 kHz

5.3 Test Environmental Conditions

Temperature:	22°C
Relative Humidity:	43 %
ATM Pressure:	102.7 kPa

The testing was performed by Jerry Huang on 20100-10-29 in RF site.

5.4 Test Equipment List and Details

Manufacturer	Description	Model	Serial Number	Calibration Date
Agilent	Spectrum Analyzer	E4440A	US45303156	2010-08-09

Statement of Traceability: BACL Corp. attests that all calibrations have been performed per the NVLAP requirements, traceable to the NIST.

5.5 Test Results

Test Mode: Transmitting

409~ 430 MHz

Power Level	Channel Spacing (kHz)	Frequency (MHz)	Conducted Output Power (dBm)	Conducted Output Power (Watt)
High	25 kHz	409.1	38.19	6.59
	25 kHz	415.0	38.31	6.78
	25 kHz	429.9	37.98	6.28
Low	25 kHz	409.1	13.62	0.023
	25 kHz	415.0	13.66	0.023
	25 kHz	429.9	13.32	0.021

6 FCC §2.1047, §90.207 & IC RSS-119 §5.2 – Modulation Characteristic

6.1 Applicable Standard

FCC §2.1047 & §90.207:

- (a) Equipment which utilizes voice modulated communication shall show the frequency response of the audio modulating circuit over a range of 100 to 5000 Hz. for equipment which is required to have a low pass filter, the frequency response of the filter, or all of the circuitry installed between the modulation limited and the modulated stage shall be supplied.
- (b) Equipment which employs modulation limiting, a curve showing the percentage of modulation versus the modulation input voltage shall be supplied.

IC RSS-119 §5.2

Equipment that operates in frequency bands other than 746-770 MHz and 794-800 MHz may employ any type of modulation. The type of modulation used shall be reported.

6.2 Test Procedure

Test Method: TIA/EIA-603-C 2.2.3

6.3 Test Result

Please refer to the hereinafter plots.

Transmitter Low Pass Filter

Type of Emission: 20K0Q7E, 20K0Q7D, 20K0Q7W, 20K0D7E, 20K0D7D, 20K0D7W
The modulation used is $\pi/4$ -shifted Differential Quaternary Phase Shift Keying ($\pi/4$ -DQPSK), with a modulation rate of 18k symbol/sec. (36k bit/sec).

A root-raised-cosine filter (RRC) is used as transmitting and receiving filter in this digital communication system to perform matched filtering.

The combined response of two such filters is that of the raised-cosine filter.

The raised-cosine filter is a filter frequently used for pulse-shaping in digital modulation known for its ability to minimize intersymbol interference (ISI).

The access scheme is TDMA with 4 physical channels per carrier.

The following graph is the transfer function of the aforementioned filter.

Plot provided by manufacturer

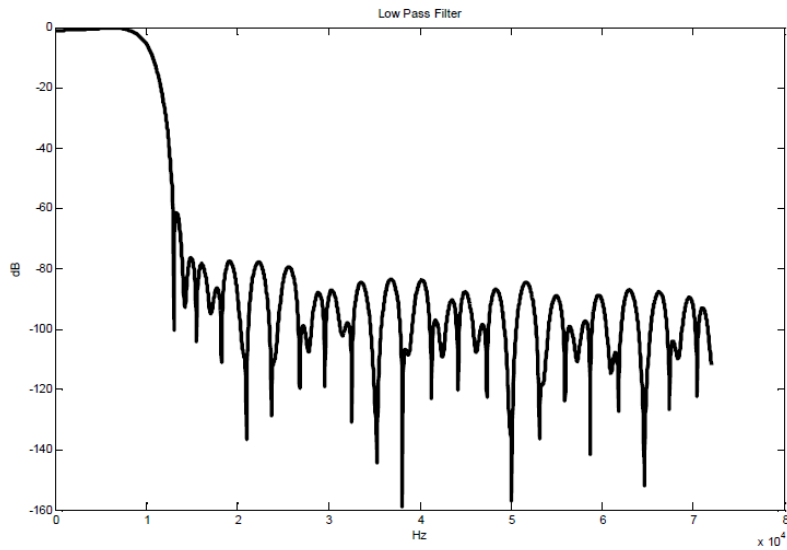

Audio Low Pass Filter

The modulation is limited by data characteristics and its filters.

In the previous section, the phase and quadrature branches (I and Q) are filtered with a root-raised-cosine filter (RRC) with a symbol rate of 18k symbol/sec. After that, the signal is pi/4 DQPSK modulated (see the plot in the previous section).

Signal processing is carried out using a Texas Instrument TLV320AIC12 codec that contains the following low pass filter.

Plot provided by manufacturer

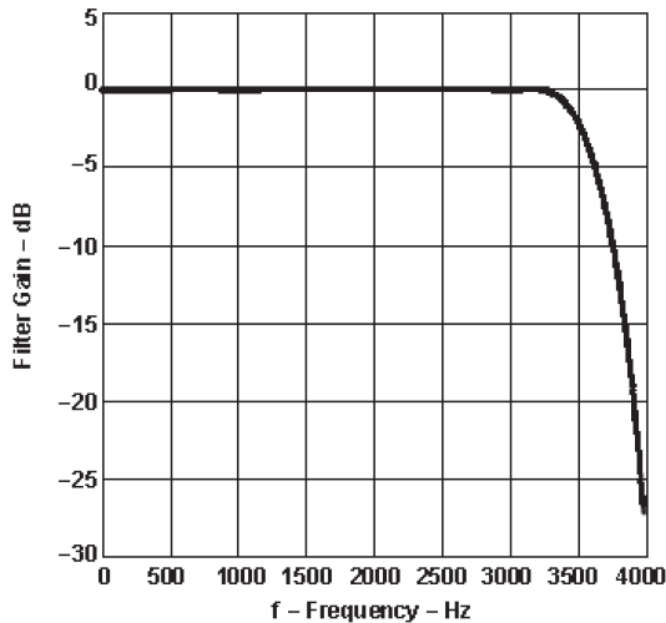

7 FCC §2.1049, §90.209, §90.210 & IC RSS-119 §5.5– Occupied Bandwidth & Emission Mask

7.1 Applicable Standard

FCC §90.209

b(5) Unless specified elsewhere, channel spacings and bandwidths that will be authorized in the following frequency bands are given in the following table.

Standard Channel Spacing/Bandwidth

Frequency band (MHz)	Channel spacing (kHz)	Authorized bandwidth (kHz)
Below 25 ²		
25–50	20	20
72–76	20	20
150–174	17.5	1,320/11.25/6
216–220 ⁵	6.25	20/11.25/6
220–222	5	4
406–512 ²	16.25	1,320/11.25/6
806–809/851–854	12.5	20
809–824/854–869	25	20
896–901/935–940	12.5	13.6
902–928 ⁴		
929–930	25	20
1427–1432 ⁵	12.5	12.5
³ 2450–2483.5 ²		
Above 2500		

FCC §2.1049, §90.210

Emission Mask B. For transmitters that are equipped with an audio low-pass filter, the power of any emission must be attenuated below the unmodulated carrier power (P) as follows:

- 1) On any frequency removed from the assigned frequency by more than 50 percent, but not more than 100 percent of the authorized bandwidth: At least 25 dB.
- 2) On any frequency removed from the assigned frequency by more than 100 percent, but not more than 250 percent of the authorized bandwidth: At least 35 dB.
- 3) On any frequency removed from the assigned frequency by more than 250 percent of the authorized bandwidth: At least $43 + 10\log(P)$ dB

The resolution bandwidth was 100Hz or greater for measuring up to 250 kHz from the edge of the authorized frequency segment, and 30 kHz or greater for measuring more than 250 kHz from the authorized frequency segment.

IC RSS-119 §5.5

5.5.3 Within the frequency ranges 138-470 MHz, transmitters which have channel bandwidths of more than 12.5 kHz can be authorized only if the minimum spectrum efficiency of one voice channel per 12.5 kHz of channel bandwidth (e.g. two voice channels per 25 kHz) is achieved.
See Section 5.7.

5.5.8 Voice input to an FM transmitter may use the spectrum mask with audio filter if it is equipped with suitable filters to be used for the audio signal only and not for other purposes. Other modulations must comply with the masks without audio filter.

5.5.9 See the relevant SRSPs for the operating frequency of the equipment channelling plan.

5.8.2 Emission Mask C.

Displacement Frequency, f_d (kHz)	Minimum Attenuation (dB)	Resolution Bandwidth (Hz)
$5 < f_d \leq 10$	$83 \log_{10}(f_d/5)$	300
$10 < f_d \leq 50$	whichever is the lesser attenuation: 50 or $29 \log_{10}(f_d^2/11)$	300
$f_d > 50$	$43 + 10 \log_{10}(p)$	Specified in Section 4.2.1

7.2 Test Procedure

The RF output of the transmitter was connected to the input of the spectrum analyzer through sufficient attenuation.

The resolution bandwidth of the spectrum analyzer was set at 100 Hz and the spectrum was recorded in the frequency band ± 50 kHz from the carrier frequency.

7.3 Test Environmental Conditions

Temperature:	22°C
Relative Humidity:	43 %
ATM Pressure:	102.7 kPa

The testing was performed by Jerry Huang on 20100-10-29 in RF site.

7.4 Test Equipment List and Details

Manufacturer	Description	Model	Serial Number	Calibration Date
Agilent	Spectrum Analyzer	E4440A	US45303156	2010-08-09

Statement of Traceability: **BACL Corp.** attests that all calibrations have been performed per the NVLAP requirements, traceable to the NIST.

7.5 Test Results

Occupied Bandwidth

High Power Middle Channel – 415MHz

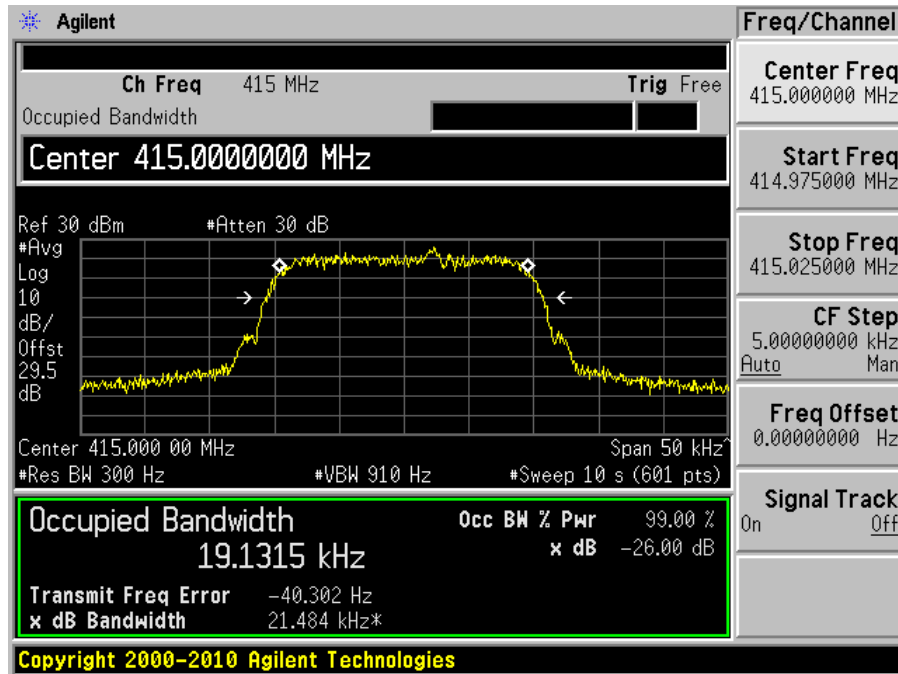

Emission Mask

Reference Power

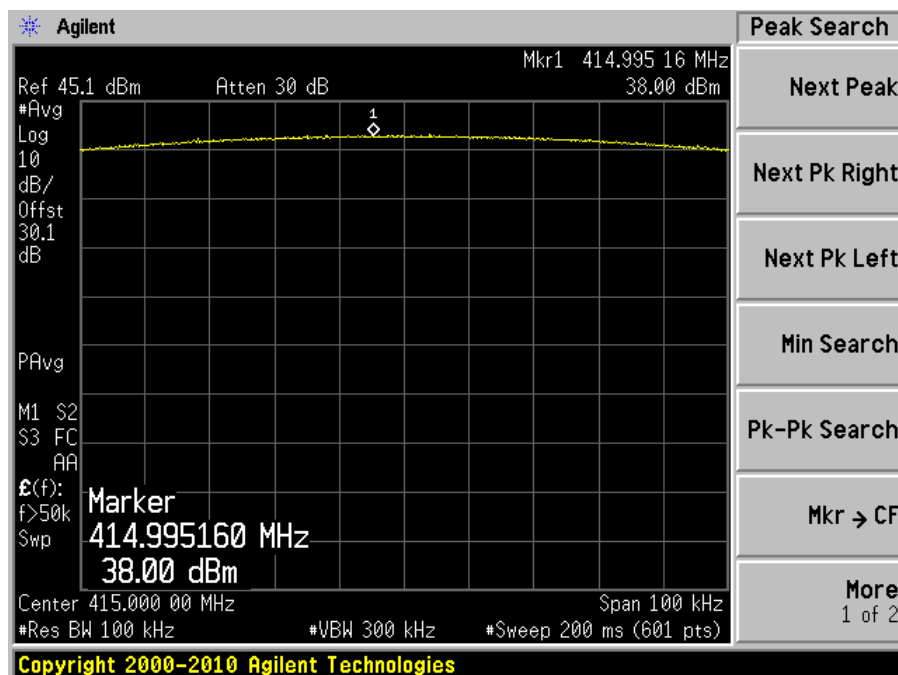

High Power Middle Channel Spacing

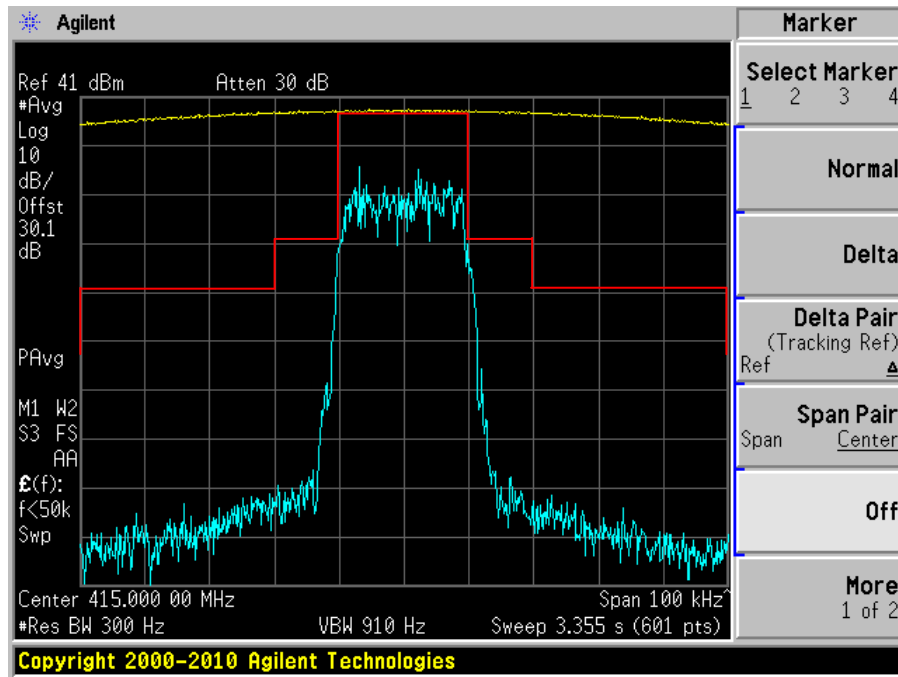

Mask B

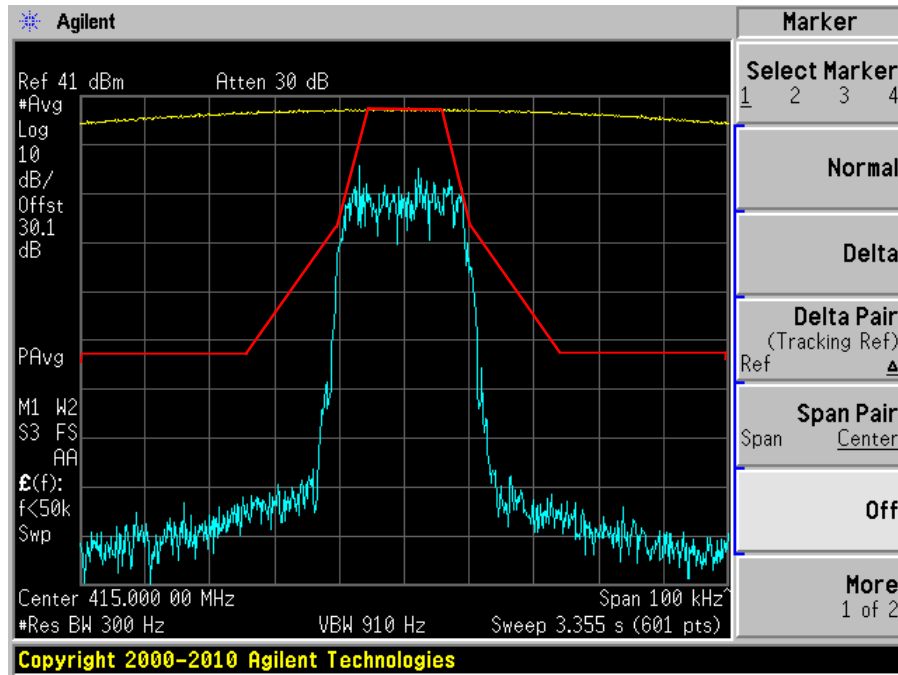

Mask C

8 FCC §2.1051, §90.210 & IC RSS-119 §5.8 - Spurious Emissions at Antenna Terminals

8.1 Applicable Standard

FCC §2.1051 and §90.210 (25 kHz bandwidth and 20 kHz bandwidth)

On any frequency removed from the center of the assigned channel by more than 250 percent at least:

$43+10\log(P)$

IC RSS-119 §5.8

8.2 Test Procedure

The RF output of the transceiver was connected to a spectrum analyzer through appropriate attenuation. The resolution bandwidth of the spectrum analyzer was set at 100 kHz. Sufficient scans were taken to show any out of band emissions up to 10th harmonic.

8.3 Test Environmental Conditions

Temperature:	22°C
Relative Humidity:	43 %
ATM Pressure:	102.7 kPa

The testing was performed by Jerry Huang on 2010-10-29 in RF site.

8.4 Test Equipment List and Details

Manufacturer	Description	Model	Serial Number	Calibration Date
Agilent	Spectrum Analyzer	E4440A	US45303156	2010-08-09

Statement of Traceability: BACL Corp. attests that all calibrations have been performed per the NVLAP requirements, traceable to the NIST.

8.5 Test Results

Please refer to the hereinafter plots.

Worst case: Middle channel (415 MHz) High Power

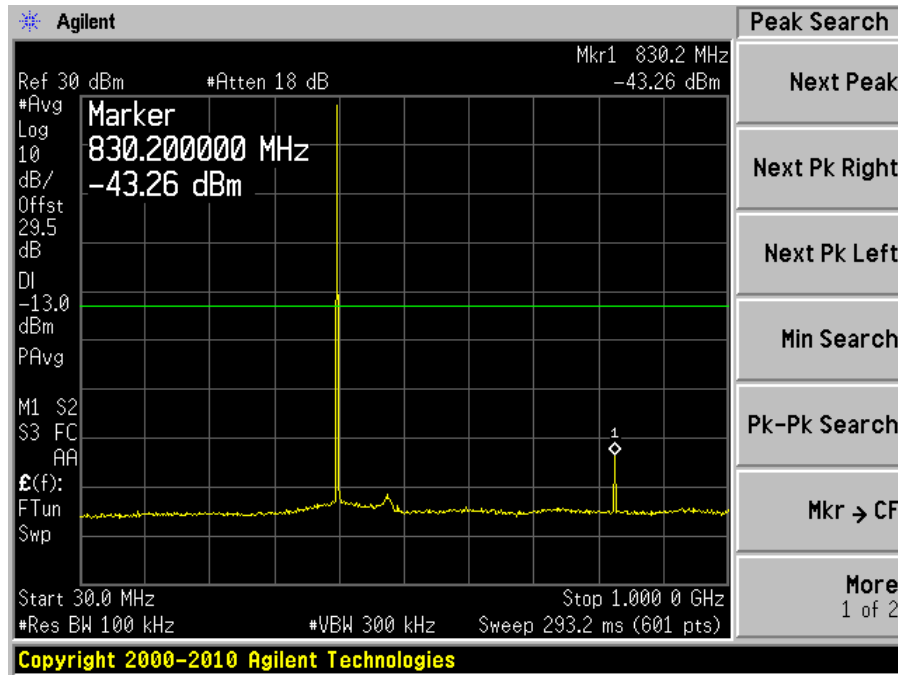

30 MHz to 1 GHz

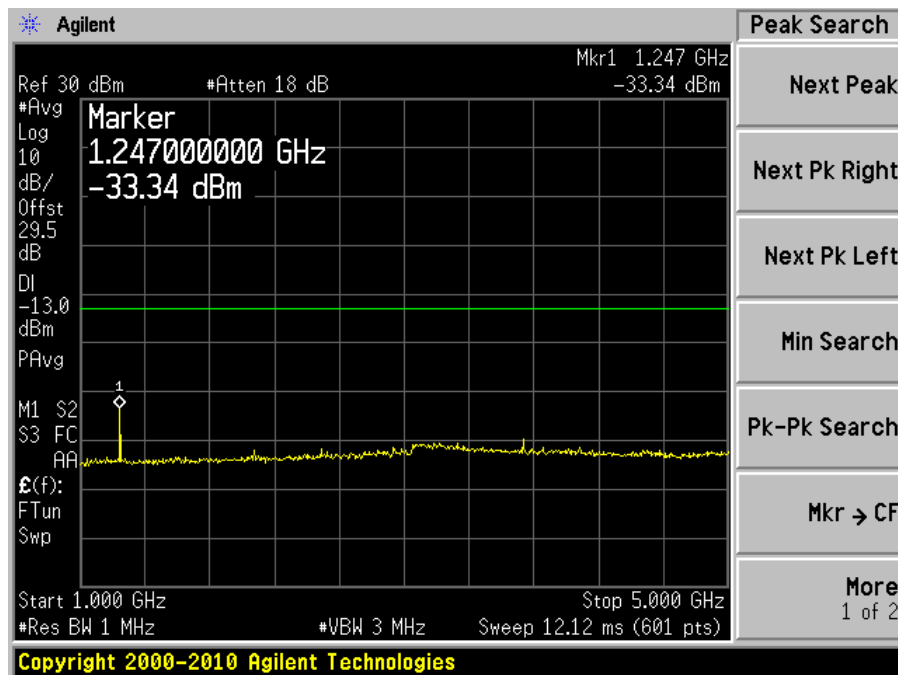

1 GHz to 5 GHz

9 FCC §2.1055 (d), §90.213 & IC RSS-119 §5.3- Frequency Stability

9.1 Applicable Standard

FCC §2.1055 (d), §90.213

(a) Unless noted elsewhere, transmitters used in the services governed by this part must have a minimum frequency stability as specified in the following table.

Minimum Frequency Stability

[Parts per million (ppm)]

Frequency range (MHz)	Fixed and base stations	Mobile stations	
		Over 2 watts output power	2 watts or less output power
Below 25	1,2,3 ¹⁰⁰	100	200
25–50	20	20	50
72–76	5		50
150–174	5,11 ⁵	6 ⁵	4,6 ⁵⁰
216–220	1.0		1.0
220–222 ¹²	0.1	1.5	1.5
421–512	7,11,14 ^{2.5}	8 ⁵	8 ⁵
806–809	14 ^{1.0}	1.5	1.5
809–824	14 ^{1.5}	2.5	2.5
851–854	1.0	1.5	1.5
854–869	1.5	2.5	2.5
896–901	14 ^{0.1}	1.5	1.5
902–928	2.5	2.5	2.5
902–928 ¹³	2.5	2.5	2.5
929–930	1.5		
935–940	0.1	1.5	1.5
1427–1435	9 ³⁰⁰	300	300
Above 2450 ¹⁰			

¹⁴Control stations may operate with the frequency tolerance specified for associated mobile frequencies.

(b) For the purpose of determining the frequency stability limits, the power of a transmitter is considered to be the maximum rated output power as specified by the manufacturer.

IC RSS-119 §5.3

Frequency Band (MHz)	Authorized Bandwidth (kHz)	Frequency Stability (ppm)		
		Base/Fixed	Mobile Station	
			>2 watts	≤ 2 watts
27.41-28 and 29.7-50	20	20	20	50
72-76	20	5	20	50
138-174	20	5	5	5
	11.25	2.5	5	5
	6.25	1	2	5
217-218 and 219-220	11.25	1	5	5
220-222 (Note 1)	4	0.1	1.5	1.5
406.1-430 and 450-470 (Note 5)	20	2.5	5	5
	11.25	1.5	2.5	2.5
	6.25	0.5	1	1
764-776 and 794-806 (Note 2)	for all authorized bandwidths	0.1 for narrowband	0.4 for narrowband (Note 3)	0.4 for narrowband (Note 3)
		1 for wideband	1.25 for wideband (Note 4)	1.25 for wideband (Note 4)
806-821/851-866 and 821-824/866-869 (Note 5)	20	1.5	2.5	2.5
	11.25	1	1.5	1.5
896-901/935-940 (Note 5)	13.6	0.1	1.5	1.5
929-930/931-932	20	1.5	N/A	N/A
928-929/952-953 and 932-932.5/941-941.5	20	1.5	N/A	N/A
	11.25	1	3 for remote station	N/A
896-901/935-940	13.6	0.1	1.5	1.5
932.5-935/941.5-944	20	2.5	N/A	N/A
	11.25	2.5	N/A	N/A

Note 5: Control stations may operate with the frequency tolerance specified for associated mobile frequencies.

9.2 Test Procedure

Frequency Stability vs. Temperature: The equipment under test was connected to an external DC power supply and the RF output was connected to the Spectrum Analyzer via feed-through attenuators. The EUT was placed inside the temperature chamber. The DC leads and RF output cable exited the chamber through an opening made for the purpose.

After the temperature stabilized for approximately 20 minutes, the frequency output was recorded from the Spectrum Analyzer.

Frequency Stability vs. Voltage: An external variable DC power supply Source. The voltage was set to 110% of the nominal value and was then decreased until the transmitter light no longer illuminated; i.e., the end point. The output frequency was recorded for each voltage.

9.3 Test Environmental Conditions

Temperature:	23 °C
Relative Humidity:	44 %
ATM Pressure:	102.4 kPa

The testing was performed by Jerry Huang on 2010-11-1 in RF site.

9.4 Test Equipment List and Details

Manufacturer	Description	Model	Serial Number	Calibration Date
Agilent	Spectrum Analyzer	E4440A	US45303156	2010-08-09
ESPEC	Oven, Temperature	ESL-4CA	18010	N/A

Statement of Traceability: BACL Corp. attests that all calibrations have been performed per the NVLAP requirements, traceable to the NIST.

9.5 Test Result

High Power, Middle Channel 415 MHz, 409-430 MHz Band

Test Condition		Reference Frequency (MHz)	Measured Frequency (MHz)	Frequency Error (PPM)	Limit (PPM)
Voltage (Vdc)	Temperature (°C)				
Frequency vs. Temperature					
13.2	50	415	414.99983	-0.409638554	± 5
13.2	40	415	415	0	± 5
13.2	30	415	415	0	± 5
13.2	20	415	414.99992	-0.192771084	± 5
13.2	10	415	414.99967	-0.795180723	± 5
13.2	0	415	414.99967	-0.795180723	± 5
13.2	-10	415	414.99967	-0.795180723	± 5
13.2	-20	415	414.99967	-0.795180723	± 5
13.2	-30	415	414.99992	-0.192771084	± 5
Frequency vs. Voltage					
15.6	20	415	414.999971	-0.069879518	± 5
10.8	20	415	415.000014	0.03373494	± 5

10 FCC §2.1053, §90.210 & IC RSS-119 §5.8 – Field Strength of Spurious Radiation

10.1 Applicable Standard

FCC §2.1053 (a) Measurements shall be made to detect spurious emissions that may be radiated directly from the cabinet, control circuits, power leads, or intermediate circuit elements under normal conditions of installation and operation. Curves or equivalent data shall be supplied showing the magnitude of each harmonic and other spurious emission. For this test, single sideband, independent sideband, and controlled carrier transmitters shall be modulated under the conditions specified in paragraph (c) of §2.1049, as appropriate, and §90.210(b),(d): Except as indicated elsewhere in this part, transmitters used in the radio services governed by this part must comply with the emission masks outlined in this section. Unless otherwise stated, per paragraphs (d)(4), (e)(4), and (m) of this section, measurements of emission power can be expressed in either peak or average values provided that emission powers are expressed with the same parameters used to specify the unmodulated transmitter carrier power. For transmitters that do not produce a full power unmodulated carrier, reference to the unmodulated transmitter carrier power refers to the total power contained in the channel bandwidth. Unless indicated elsewhere in this part, the table in this section specifies the emission masks for equipment operating in the frequency bands governed under this part.

IC RSS-119 §5.8

10.2 Test Procedure

The transmitter was placed on a Styrofoam with wooden turntable, and it was normal transmitting with 50ohm termination which was also placed on the turntable.

The measurement antenna was placed at a distance of 3 meters from the EUT. During the tests, the antenna height and polarization as well as EUT azimuth were varied in order to identify the maximum level of emissions from the EUT. The test was performed by placing the EUT on 3-orthogonal axis.

The frequency range up to tenth harmonic of the fundamental frequency was investigated.

Remove the EUT and replace it with substitution antenna. A signal generator was connected to the substitution antenna by a non-radiating cable. The absolute levels of the spurious emissions were measured by the substitution.

Spurious emissions in dB = 10 lg (TXpwr in Watts/0.001) – the absolute level

10.3 Test Environmental Conditions

Temperature:	24 °C
Relative Humidity:	44 %
ATM Pressure:	102.6kPa

The testing was performed by Jerry Huang on 2010-11-3 in chamber #3.

10.4 Test Equipment List and Details

Manufacturer	Description	Model	Serial Number	Calibration Date
Rohde & Schwarz	EMI Test Receiver	ESCI 1166.5950K03	100337	2010-03-24
Agilent	Spectrum Analyzer	E4440A	US45303156	2010-08-09
Sunol Science Corp	System Controller	SC99V	122303-1	N/R
Sunol Science Corp	Combination Antenna	JB1	A020106-1	2010-05-28
Hewlett Packard	Pre amplifier	8447D	2944A06639	2010-06-18
EMCO	Horn antenna	3115	9511-4627	2010-08-09
Agilent	Amplifier, Pre	8449B	3008A01978	2010-01-29

Statement of Traceability: BACL attests that all calibrations have been performed per the NVLAP requirements, traceable to NIST.

10.5 Test Results

High Power Middle Channel (415 MHz)

-24.434 dB at 3735 MHz in the Vertical polarization

Test Mode: Transmission Using substitution method

Indicated		Turntable Azimuth degrees	Test Antenna		Substituted					Limit (dBm)	Margin (dB)
Freq. (MHz)	Amp. (dBuV)		Height (cm)	Polar (H/V)	Freq. (MHz)	Level (dBm)	Antenna Cord. (dBi)	Cable Loss (dB)	Absolute Level (dBm)		
830	49.50	132	100	H	830	-47.49	0	0.97	-48.460	-13	-35.46
830	40.47	188	141	V	830	-54.53	0	0.97	-55.500	-13	-42.50
1245	54.12	158	232	H	1245	-55.47	6.522	1.00	-49.948	-13	-36.948
1245	50.89	181	150	V	1245	-59.31	6.522	1.00	-53.788	-13	-40.788
2075	54.91	210	114	H	2075	-50.50	8.606	1.32	-43.214	-13	-30.214
2075	54.34	286	109	V	2075	-50.27	8.606	1.32	-42.984	-13	-29.984
3735	51.94	141	214	H	3735	-45.83	9.846	1.66	-37.644	-13	-24.644
3735	52.00	122	121	V	3735	-45.62	9.846	1.66	-37.434	-13	-24.434

11 FCC §90.214 & IC RSS-119 §5.9 - Transient Frequency Behavior

11.1 Applicable Standard

FCC §90.214: Transmitters designed to operate in the 150–174 MHz and 421–512 MHz frequency bands must maintain transient frequencies within the maximum frequency difference limits during the time intervals indicated:

Time intervals ^{1,2}	Maximum frequency difference ³	All equipment
		421 to 512 MHz
Transient Frequency Behavior for Equipment Designed to Operate on 25 kHz Channels		
t_1^4	±25.0 kHz	10.0 ms
t_2	±12.5 kHz	25.0 ms
t_3^4	±25.0 kHz	10.0 ms
Transient Frequency Behavior for Equipment Designed to Operate on 12.5 kHz Channels		
t_1^4	±12.5 kHz	10.0 ms
t_2	±6.25 kHz	25.0 ms
t_3^4	±12.5 kHz	10.0 ms

IC RSS-119 §5.9, When a transmitter is turned on, the radio frequency may take some time to stabilize. During this initial period, the frequency error or frequency difference (i.e. between the instantaneous and the steady state frequencies) must not exceed the limits specified in Table 16.

Table 16 - Transient Frequency Behaviour

Channel Spacing (kHz)	Time Intervals ^{1,2}	Maximum Frequency Difference (kHz)	Transient Duration Limit (ms)	
			138-174 MHz	406.1-512 MHz
25	t_1	±25	5	10
	t_2	±12.5	20	25
	t_3	±25	5	10
12.5	t_1	±12.5	5	10
	t_2	±6.25	20	25
	t_3	±12.5	5	10
6.25	t_1	±6.25	5	10
	t_2	±3.125	20	25
	t_3	±6.25	5	10

¹ t_{on} : the instant when a 1 kHz test signal is completely suppressed, including any capture time due to phasing.

t_1 : the time period immediately following t_{on} .

t_2 : the time period immediately following t_1 .

t_3 : the time period from the instant when the transmitter is turned off until t_{off} .

t_{off} : the instant when the 1 kHz test signal starts to rise.

² If the transmitter carrier output power rating is 6 W or less, the frequency difference during the time periods t_1 and t_3 may exceed the maximum frequency difference for these time periods. The corresponding plot of frequency versus time during t_1 and t_3 shall be recorded in the test report.

11.2 Test Procedure

TIA/EIA-603-C 2.2.19

11.3 Test Environmental Conditions

Temperature:	22 °C
Relative Humidity:	47 %
ATM Pressure:	102.6 kPa

The testing was performed by Jerry Huang on 2010-11-02 in RF site.

11.4 Test Equipment List and Details

Manufacturer	Description	Model	Serial Number	Calibration Date
HP	Modulation Analyzer	8901A	2026A00847	2010-08-17
Tektronix	Digital Phosphor Oscilloscope	TDS7104	B020557	2010-06-11
HP	Generator, Signal	83650B	3614A00276	2010-06-21
BK Precision	Power Supply, DC	1621A	D185052265	N/R
Agilent	Spectrum Analyzer	E4440A	US45303156	2010-08-09
HP	Test Set, RF Communications	8920A	3438A05338	2010-05-18

Statement of Traceability: BACL Corp. attests that all calibrations have been performed per the NVLAP requirements, traceable to the NIST

11.5 Test Results

Please refer to the following plots.

11.6 Test Setup Block Diagram

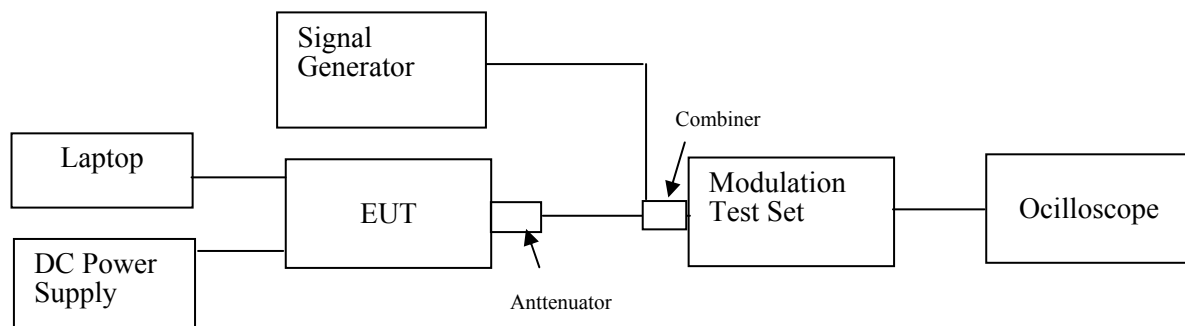

Powering Up

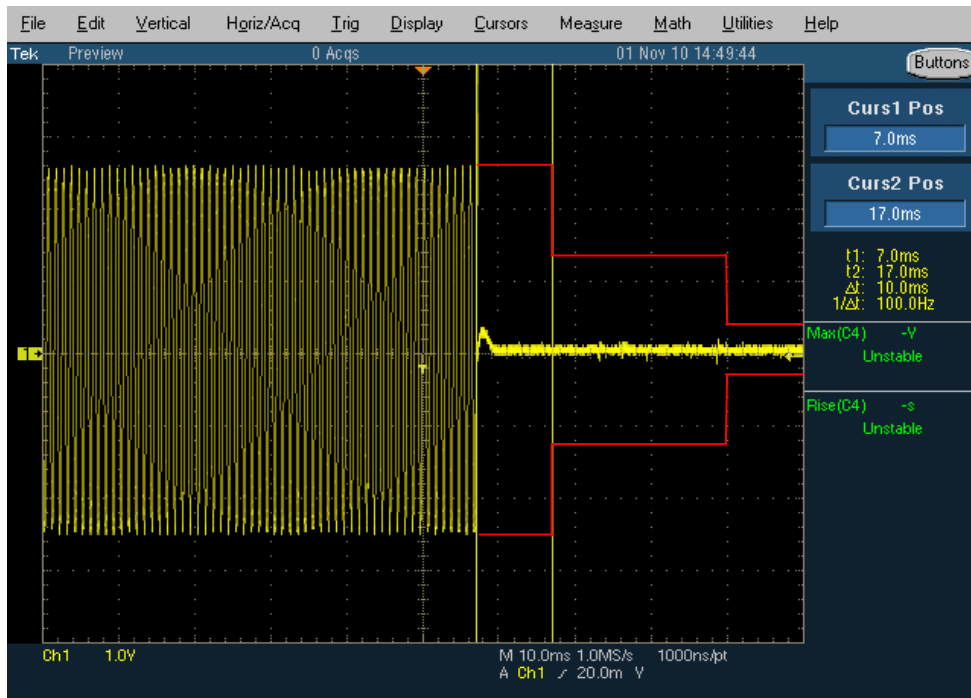

Powering Down

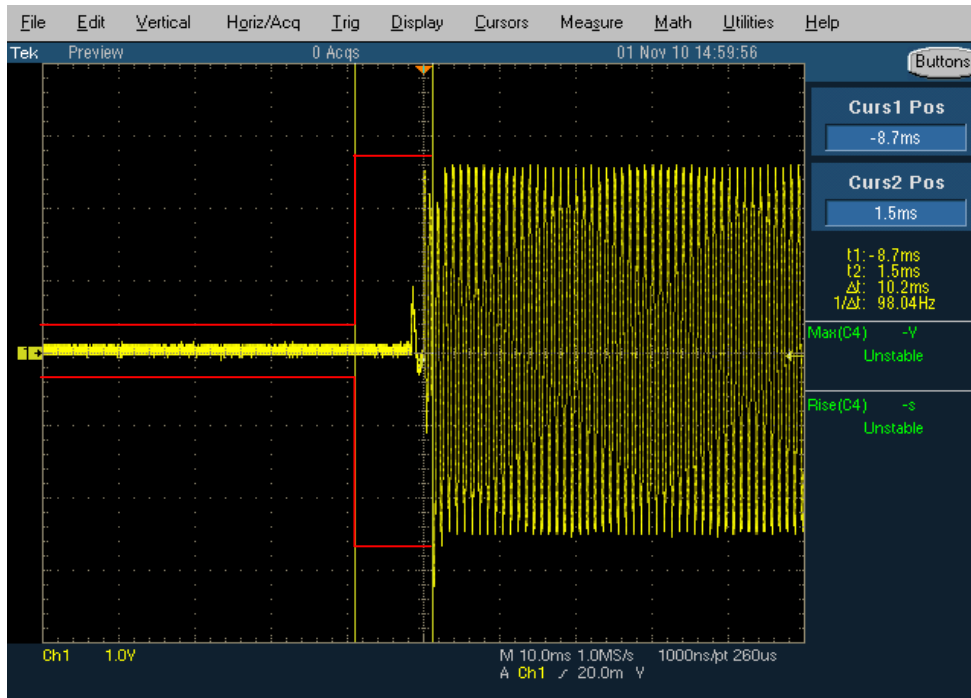

12 IC RSS-119 §5.11 & IC RSS-310 §3.1 Receiver Spurious Radiated Emissions

12.1 Applicable Standard

IC RSS-119 §5.11, IC RSS-310 §3.1 and RSS-Gen §6

The following receiver spurious emission limits shall be complied with:

(a) If a radiated measurement is made, all spurious emissions shall comply with the limits of Table 1.

Table 1 - Spurious Emission Limits for Receivers

Frequency (MHz)	Field Strength Microvolts/m at 3 meters
	Receivers
30-88	100
88-216	150
216-960	200
Above 960	500

12.2 Test Block Diagram

RX Spurious Emissions

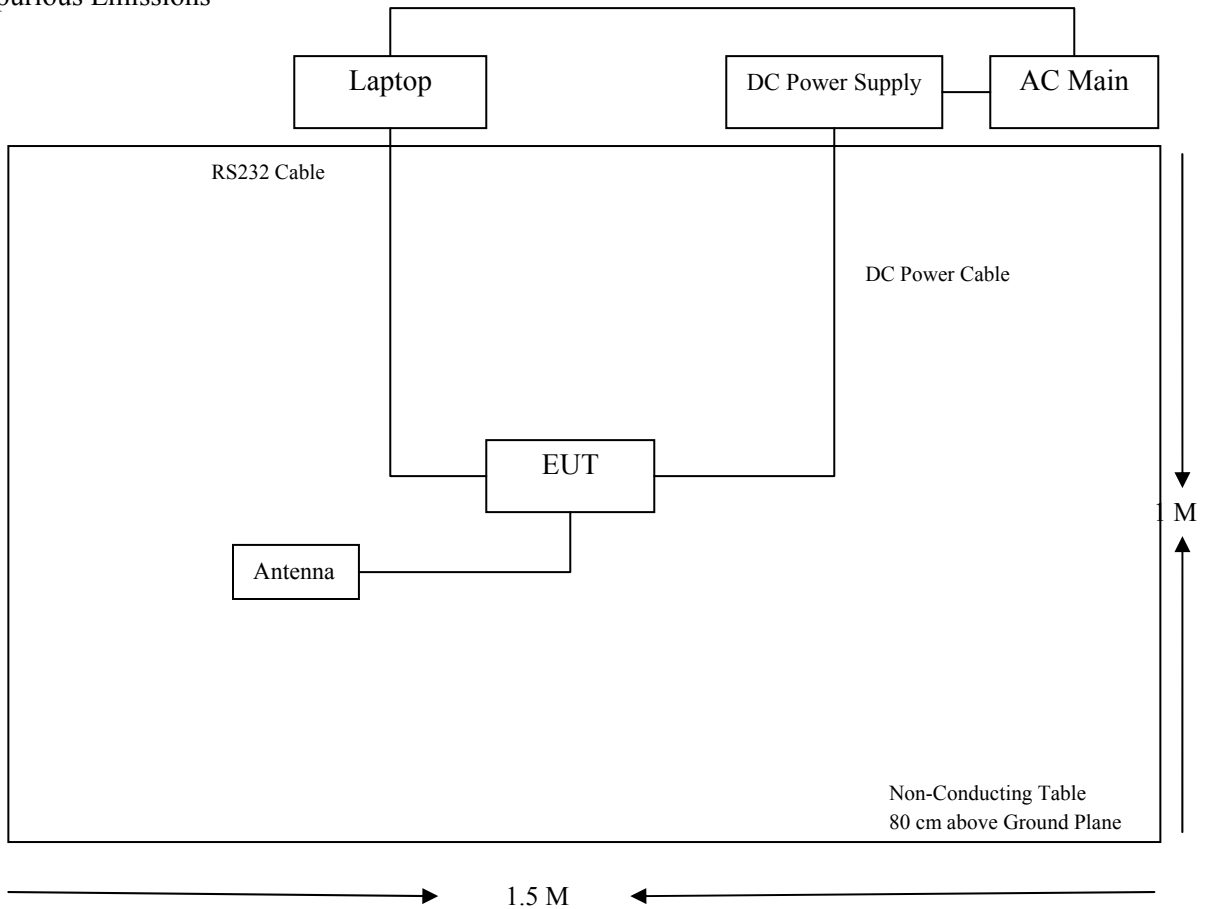

GPS Receiver Spurious Emissions

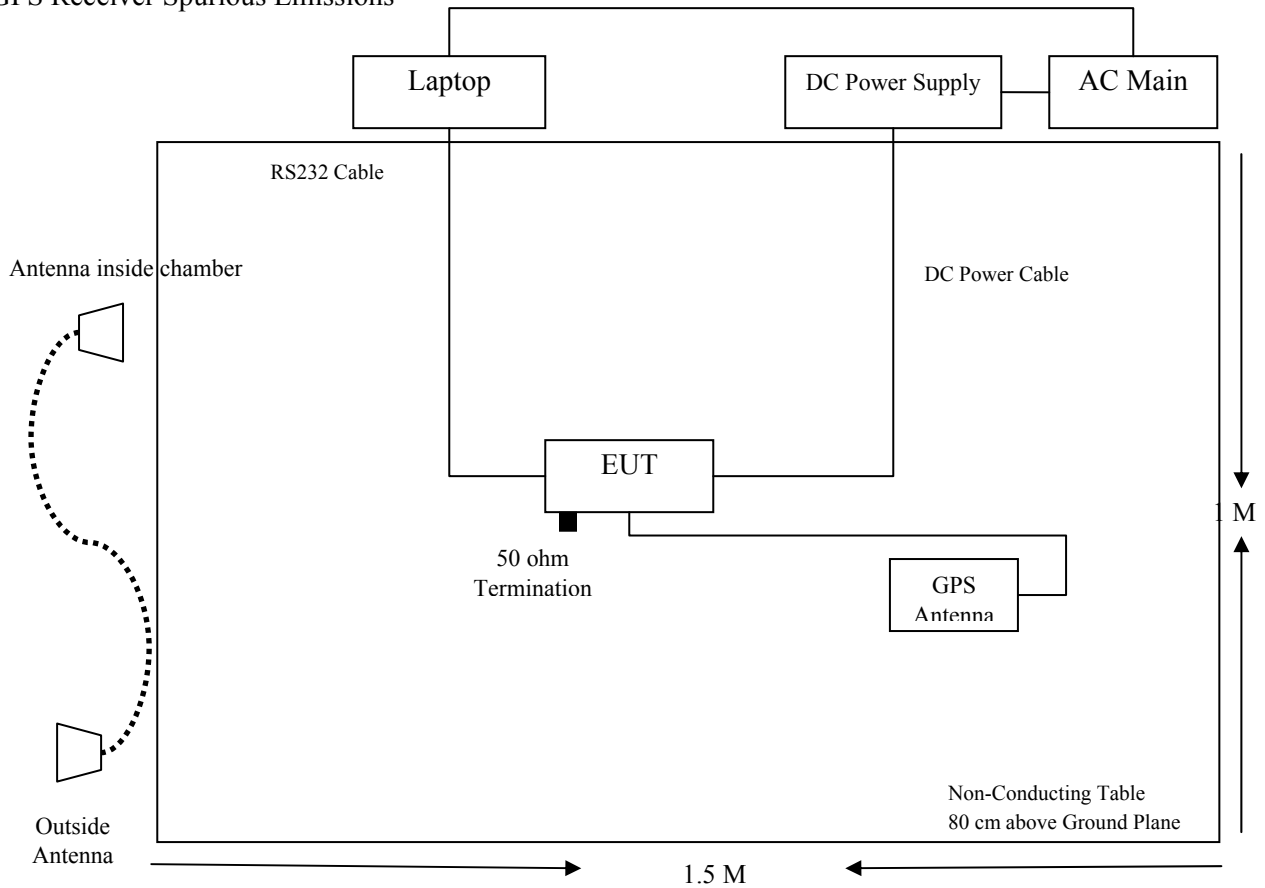

12.3 Test Equipment Lists and Details

Manufacturer	Description	Model	Serial Number	Calibration Date
Rohde & Schwarz	EMI Test Receiver	ESCI 1166.5950K03	100337	2010-03-24
Agilent	Spectrum Analyzer	E4440A	US45303156	2010-08-09
Sunol Science Corp	System Controller	SC99V	122303-1	N/R
Sunol Science Corp	Combination Antenna	JB3	A0020106-3	2010-06-16
Hewlett Packard	Pre amplifier	8447D	2944A06639	2010-06-18
EMCO	Horn antenna	3115	9511-4627	2010-08-09
Mini-Circuits	Pre Amplifier	ZVA-183-S	570400946	2010-05-10

Statement of Traceability: BACL Corp. attests that all calibrations have been performed per the NVLAP requirements, traceable to the NIST.

12.4 Test Environmental Conditions

Temperature:	24 °C
Relative Humidity:	44 %
ATM Pressure:	102.6kPa

The testing was performed by Jerry Huang on 2010-11-3 in chamber #3.

12.5 Test Procedure

Maximizing procedure was performed on the six (6) highest emissions to ensure EUT compliance is with all installation combinations.

12.6 Corrected Amplitude & Margin Calculation

The Corrected Amplitude is calculated by adding the Antenna Factor and Cable Factor, and subtracting the Amplifier Gain from the Amplitude reading. The basic equation is as follows:

$$\text{Corrected Amplitude} = \text{Indicated Reading} + \text{Antenna Factor} + \text{Cable Factor} - \text{Amplifier Gain}$$

The “**Margin**” column of the following data tables indicates the degree of compliance with the applicable limit. For example, a margin of -7 dB means the emissions are 7 dB below the maximum limit. The equation for margin calculation is as follows:

$$\text{Margin} = \text{Corrected Amplitude} - \text{Limit}$$

12.7 Summary of Test Results

According to the test data, the EUT complied RSS Gen, with the worst margins from the limit listed below:

Measure at 3 Meters (30 MHz – 1 GHz)

Model: Receiving			
Margin (dB)	Frequency (MHz)	Polarization (Horizontal/Vertical)	Test Range
-8.64	82.94275	Vertical	30 MHz-1 GHz

Measure at 3 Meters (Above 1 GHz)

Mode: Receiving			
Margin (dB)	Frequency (MHz)	Polarization (Horizontal/Vertical)	Test Range
-	-	-	1 GHz – 6 GHz

Note: All emission levels are at the noise floor and/or more than 20 dB below the limit.

GPS Receiver Spurious Emission:

Measure at 3 Meters (30 MHz – 1 GHz)

Model: Receiving			
Margin (dB)	Frequency (MHz)	Polarization (Horizontal/Vertical)	Test Range
-0.44	322.5796	Horizontal	30 MHz-1 GHz

Measure at 3 Meters (Above 1 GHz)

Mode: Receiving			
Margin (dB)	Frequency (MHz)	Polarization (Horizontal/Vertical)	Test Range
-	-	-	1 GHz – 6 GHz

Note: All emission levels are at the noise floor and/or more than 20 dB below the limit.

12.8 Radiated Spurious Emissions Plot & Data

RX Spurious Emissions:

1) Measured at 3 Meter Distance (30 MHz – 1 GHz)

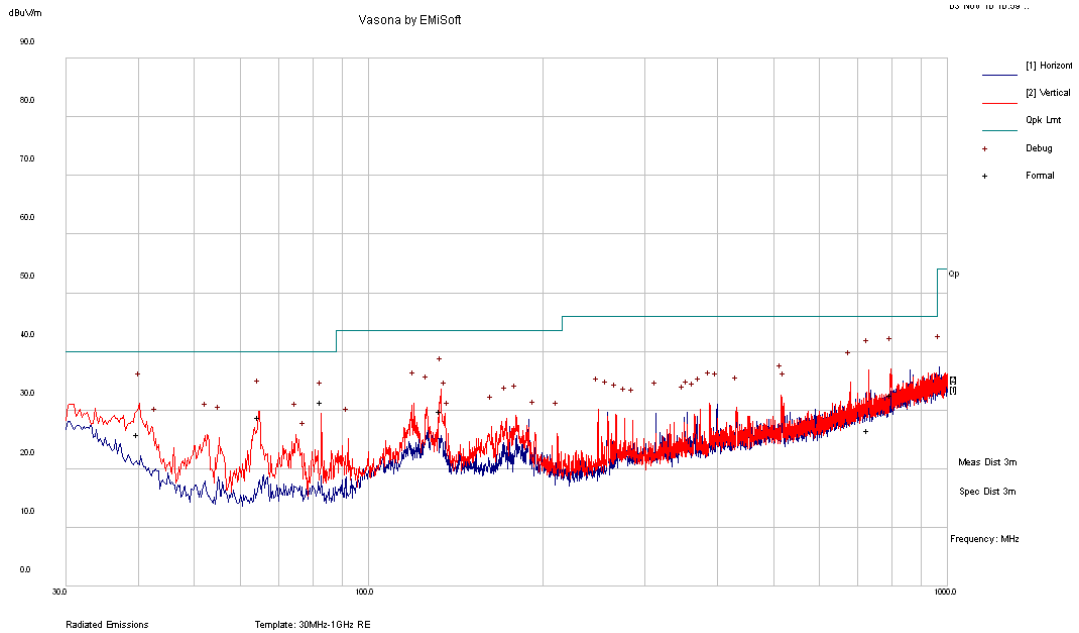

Frequency (MHz)	Corrected Amplitude (dBµV/m)	Antenna Height (cm)	Antenna Polarity (H/V)	Turntable Azimuth (degrees)	Limit (dBµV/m)	Margin (dB)
39.95500	25.87	146	V	34	40	-14.13
64.51675	28.80	136	V	342	40	-11.20
82.94275	31.36	134	V	43	40	-8.64
133.17500	29.89	127	V	166	43.5	-13.61
729.44150	26.52	127	V	316	46	-19.48
799.03280	32.63	105	V	359	46	-13.37

2) Measured at 3 Meter Distance (1 GHz – 6 GHz)

Frequency (MHz)	Corrected Amplitude (dBµV/m)	Antenna Height (cm)	Antenna Polarity (H/V)	Turntable Azimuth (degrees)	Limit (dBµV/m)	Margin (dB)
-	-	-	-	-	-	-

Note: All emission levels are at the noise floor and/or more than 20 dB below the limit.

GPS Receiver Spurious Emissions:

1) Measured at 3 Meter Distance (30 MHz – 1 GHz)

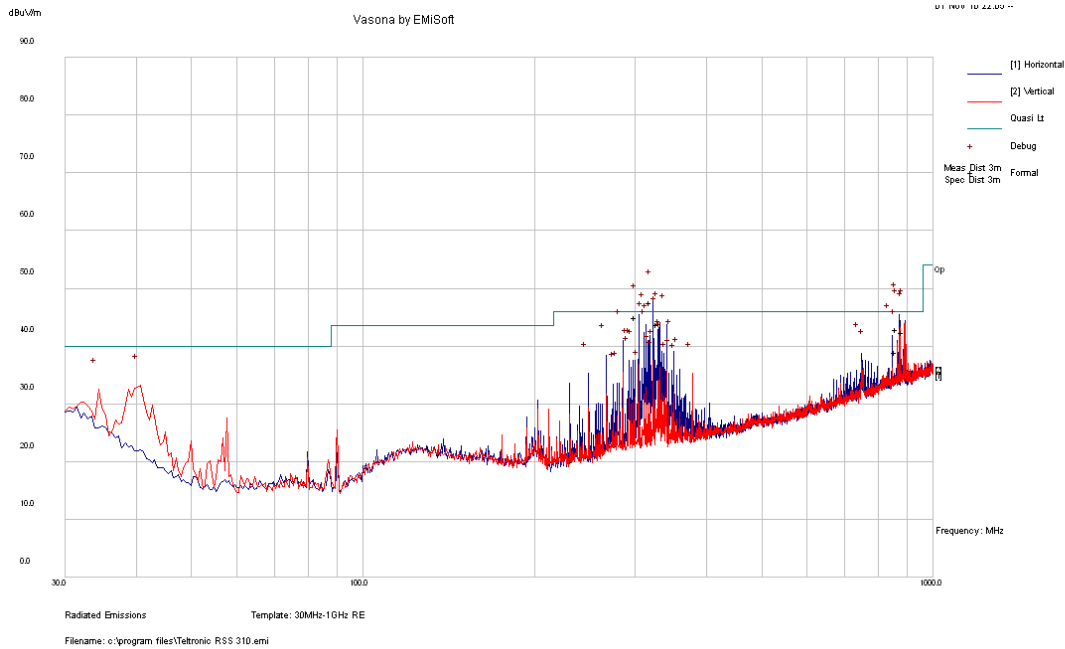

Frequency (MHz)	Corrected Amplitude (dBµV/m)	Antenna Height (cm)	Antenna Polarity (H/V)	Turntable Azimuth (degrees)	Limit (dBµV/m)	Margin (dB)
322.5796	45.56	100	H	288	46	-0.44
304.1265	44.93	106	H	291	46	-1.07
331.772	43.88	100	H	73	46	-2.12
873.2021	42.96	143	H	126	46	-3.04
893.6441	42.37	133	H	122	46	-3.63
870.2655	39.01	232	H	288	46	-6.99

2) Measured at 3 Meter Distance (1 GHz – 6 GHz)

Frequency (MHz)	Corrected Amplitude (dBµV/m)	Antenna Height (cm)	Antenna Polarity (H/V)	Turntable Azimuth (degrees)	Limit (dBµV/m)	Margin (dB)
-	-	-	-	-	-	-

Note: All emission levels are at the noise floor and/or more than 20 dB below the limit.