

FCC PART 90



TEST AND MEASUREMENT REPORT

For

Teltronic S.A.U.

Poligono Malpica, Calle F Oeste,
50057 Zaragoza, Spain

FCC ID: WT7PTRKTHTT500410
Model: HTT-500 409-470MHz

Report Type: CIIPC Report	Product Type: PTT Handheld Radio
Test Engineer: <u>Jack Liu</u>	
Report Number: <u>R1108012-90</u>	
Report Date: <u>2011-09-14</u>	
Reviewed By: <u>EMC/RF Lead</u>	Victor Zhang 
Prepared By: (84) Bay Area Compliance Laboratories Corp. 1274 Anvilwood Avenue, Sunnyvale, CA 94085, U.S.A. Tel: (408) 732-9162 Fax: (408) 732 9164 www.baclcorp.com	

Note: This test report is prepared for the customer shown above and for the device described herein. It may not be duplicated or used in part without prior written consent from Bay Area Compliance Laboratories Corp. This report **must not** be used by the customer to claim product certification, approval, or endorsement by NVLAP*, NIST, or any agency of the Federal Government.

* This report may contain data that are not covered by the NVLAP accreditation and are marked with an asterisk "*" 8000

TABLE OF CONTENTS

1.	General Information.....	5
1.1	PRODUCT DESCRIPTION FOR EQUIPMENT UNDER TEST (EUT).....	5
1.2	MECHANICAL DESCRIPTION	5
1.3	OBJECTIVE.....	5
1.4	RELATED SUBMITTAL(S)/GRANT(S)	6
1.5	TEST METHODOLOGY	6
1.6	MEASUREMENT UNCERTAINTY	6
1.7	TEST FACILITY	6
2	System Test Configuration.....	7
2.1	JUSTIFICATION.....	7
2.2	EUT EXERCISE SOFTWARE.....	7
2.3	EQUIPMENT MODIFICATIONS	7
2.4	LOCAL SUPPORT EQUIPMENT	7
2.5	INTERNAL CONFIGURATION.....	7
2.6	LOCAL SUPPORT EQUIPMENT POWER SUPPLY AND LINE FILTERS	7
2.7	INTERFACE PORTS AND CABLING	7
2.8	TEST SETUP BLOCK DIAGRAM.....	8
3	Summary of Test Results	9
4	FCC §2.1093 - RF Exposure Information	10
4.1	APPLICABLE STANDARDS	10
4.2	RESULT.....	10
5	FCC §2.1046 & §90.205 – RF Output Power	11
5.1	APPLICABLE STANDARD	11
5.2	TEST PROCEDURE	11
5.3	TEST EQUIPMENT LIST AND DETAILS	11
5.4	TEST ENVIRONMENTAL CONDITIONS.....	11
5.5	TEST RESULTS	11
6	FCC §2.1047 & §90.207 – Modulation Characteristic.....	12
6.1	APPLICABLE STANDARD	12
6.2	TEST PROCEDURE	12
6.3	TEST RESULTS	12
7	FCC §2.1051, §90.221(d) & FCC 11-63 - Spurious Emissions at Antenna Terminals.....	14
7.1	APPLICABLE STANDARD	14
7.2	TEST PROCEDURE	14
7.3	TEST EQUIPMENT LIST AND DETAILS	14
7.4	TEST ENVIRONMENTAL CONDITIONS.....	14
7.5	TEST RESULTS	14
8	FCC §2.1055 (d) & §90.213 - Frequency Stability	18
8.1	APPLICABLE STANDARD	18
8.2	TEST RESULT.....	18
9	FCC §2.1053, §90.221(d) & FCC 11-63 – Field Strength of Spurious Radiation.....	19
9.1	APPLICABLE STANDARD	19
9.2	TEST PROCEDURE	19
9.3	TEST EQUIPMENT LIST AND DETAILS	19
9.4	TEST ENVIRONMENTAL CONDITIONS.....	20

9.5	TEST RESULTS	20
10	FCC §90.214 - Transient Frequency Behavior.....	21
10.1	APPLICABLE STANDARD	21
10.2	TEST PROCEDURE	21
10.3	TEST SETUP BLOCK DIAGRAM.....	21
10.4	TEST EQUIPMENT LIST AND DETAILS	22
10.5	TEST ENVIRONMENTAL CONDITIONS.....	22
10.6	TEST RESULTS	22
11	FCC 11-63 – Adjacent Channel Power and Wideband Noise.....	24
11.1	APPLICABLE STANDARD	24
11.2	TEST SETUP BLOCK DIAGRAM.....	25
11.3	TEST EQUIPMENT LIST AND DETAILS	26
11.4	TEST ENVIRONMENTAL CONDITIONS.....	26
11.5	TEST RESULTS	26
12	EXHIBIT A - FCC Labeling Requirements.....	31
12.1	FCC ID LABEL REQUIREMENT	31
12.2	FCC LABEL CONTENTS	32
12.3	FCC ID LABEL LOCATION ON EUT	33
13	EXHIBIT B - Test Setup Photographs	34
13.1	BELOW 1 GHZ RADIATED EMISSION – FRONT VIEW	34
13.2	BELOW 1 GHZ RADIATED EMISSION – REAR VIEW	34
13.3	ABOVE 1 GHZ RADIATED EMISSION – FRONT VIEW.....	35
13.4	ABOVE 1 GHZ RADIATED EMISSION – REAR VIEW	35
14	EXHIBIT C - EUT Photographs	36
14.1	EUT - FRONT VIEW	36
14.2	EUT – REAR VIEW	36
14.3	EUT-MAIN BOARD – TOP SIDE VIEW.....	37
14.4	EUT- MAIN BOARD – BOTTOM SIDE VIEW	37
14.5	EUT- GPS BOARD – TOP SIDE VIEW.....	38
14.6	EUT- GPS BOARD – BOTTOM SIDE VIEW	38
14.7	EUT- MMI BOARD – TOP SIDE VIEW.....	39
14.8	EUT- MMI BOARD – BOTTOM SIDE VIEW	39
14.9	409~470 MHZ LONG ANTENNA VIEW.....	40
14.10	409~430 MHZ SHORT ANTENNA VIEW.....	40
14.11	450~470 MHZ SHORT ANTENNA VIEW.....	41

DOCUMENT REVISION HISTORY

Revision Number	Report Number	Description of Revision	Date of Revision
0	R1108012-90	Original Report	2011-09-14

1. General Information

1.1 Product Description for Equipment under Test (EUT)

The report has been prepared on behalf of Teltronic S.A.U. and their product, FCC ID: WT7PTRKTHTT500410, model: HTT-500 409-470 MHz or the EUT as referred to in the rest of this report. The EUT is a Digital handheld terminal.

The EUT is a 409-430 MHz and 450-470 MHz Transceiver that operates under FCC Part 90

Specifications	
Frequency Band	409-470 MHz
Emission designator	20K0D7E, 20K0D7D, 20K0D7W, 20K0Q7E, 20K0Q7D, 20K0Q7W. 22K0D7E, 22K0D7D, 22K0D7W, 22K0Q7E, 22K0Q7D, 22K0Q7W.
Modulation	$\pi/4$ -DQPSK TDMA 4 slots
RF Output Power	20 kHz - 2 Watts 22 kHz - 3 Watts
RF Channel Spacing	25 kHz (Spectrum Efficiency 6.25 kHz) ^{Note 1}
Necessary/Authorized Bandwidth	20, 22 kHz
Power Supply	7.4 Vdc Li-Pol battery

Note 1: TETRA access scheme is TDMA with 4 physical channels per carrier. The channel bandwidth is 25 kHz. As a result, the equipment meets a spectrum efficiency standard of one voice channel per 6.25 kHz of channel bandwidth. Modulation is $\pi/4$ -DQPSK with 18Ksym/sec. This modulation is based on transmitting two bits per symbol, so the data rate on each sub-carrier is 9000 bits/sec (higher than 4800 bits per second per 6.25 kHz of channel bandwidth).

1.2 Mechanical Description

The EUT measures approximately 16cm (L) x 6cm (W) x 4cm (H) and weighs 397.5g with battery, 297.5g without battery.

The test data gathered are from production sample. Serial number: 000127031572930 provided by the manufacturer.

1.3 Objective

This Type approval report is prepared on behalf of *Teltronic S.A.U.* in accordance with Part 90 of the Federal Communication Commissions rules and FCC 11-63 (WT Docket No.11-69, ET Docket No. 09-234).

This is class II permissive change report is based on an RF output Power, Spurious Emission, Frequency Stability, Receiver Spurious Emission, Adjacent Channel Power, and Wideband Noise to determine compliance with the FCC rules.

This test and measurement report only pertains to the 22 kHz Occupied Bandwidth portion of the EUT for 450-470 MHz band.

1.4 Related Submittal(s)/Grant(s)

FCC ID: WT7PTRKTHTT500410 original test report.

1.5 Test Methodology

All tests and measurements indicated in this document were performed in accordance with the Code of federal Regulations Title 47 Part 2, Sub-part J as well as the following individual parts:

Part 90 – Private Land Mobile Radio Service

FCC 11-63(WT Docket No.11-69, ET Docket No. 09-234)

Applicable Standards:TIA603-C and ANSI 63.4-2003, American National Standard for Method of Measurement of Radio-Noise Emissions from Low-Voltage Electrical and Electronic Equipment in the range of 9 kHz to 40 GHz.

All emissions measurement was performed by Bay Area Compliance Laboratories Corp. The radiated testing was performed at an antenna-to-EUT distance of 3 meters.

1.6 Measurement Uncertainty

All measurements involve certain levels of uncertainties, especially in the field of EMC. The factors contributing to uncertainties are spectrum analyzer, cable loss, antenna factor calibration, antenna directivity, antenna factor variation with height, antenna phase center variation, antenna factor frequency interpolation, measurement distance variation, site imperfections, mismatch (average), and system repeatability.

Based on NIS 81, The Treatment of Uncertainty in EMC Measurements, the values ranging from ± 2.0 dB for Conducted Emissions tests and ± 4.0 dB for Radiated Emissions tests are the most accurate estimates pertaining to uncertainty of EMC measurements at BACL Corp.

1.7 Test Facility

The test site used by BACL Corp. to collect radiated and conducted emissions measurement data is located at its facility in Sunnyvale, California, USA.

The test sites at BACL have been fully described in reports submitted to the Federal Communication Commission (FCC) and Voluntary Control Council for Interference (VCCI). The details of these reports has been found to be in compliance with the requirements of Section 2.948 of the FCC Rules on February 11 and December 10, 1997 and Article 8 of the VCCI regulations on December 25, 1997. The facility also complies with the radiated and AC line conducted test site criteria set forth in ANSI C63.4-2003.

The Federal Communications Commission, Industry Canada, and Voluntary Control Council for Interference has the reports on file and is listed under FCC registration number: 90464, IC registration number: 3062A, and VCCI Registration Number: C-2463 and R-2698. The test site has been approved by the FCC, IC, and VCCI for public use and is listed in the FCC Public Access Link (PAL) database.

Additionally, BACL is a National Institute of Standards and Technology (NIST) accredited laboratory, under the National Voluntary Laboratory Accredited Program (Lab Code 200167-0). The current scope of accreditations can be found at <http://ts.nist.gov/ts/htdocs/210/214/scopes/2001670.htm>

2 System Test Configuration

2.1 Justification

The EUT was configured for testing according to TIA/EIA-603-C.

The EUT was tested in the normal (native) operating mode to represent *worst*-case results during the final qualification test.

2.2 EUT Exercise Software

The EUT is using TDriver 1.0.0.

2.3 Equipment Modifications

No modifications were made to the EUT.

2.4 Local Support Equipment

Manufacturer	Description	Model No.	Serial No.
Dell	Laptop	D600	37140867901
Dell	Desktop	DCCY	CNC6PC1

2.5 Internal Configuration

Manufacturer	Description	Model No.	Serial No.
Teltronic S.A.U.	Main Board	F072001	-
Teltronic S.A.U.	MMI Board	F072002	-
Teltronic S.A.U.	GPS Board	F072004	-

2.6 Local Support Equipment Power Supply and Line Filters

Manufacturer	Description	Model	Serial Number
BK PRECISION	DC power supply	1612A	D185052265

2.7 Interface Ports and Cabling

Cable Description	Length (m)	From	To
Serial cable	>1.0	Laptop Serial port	EUT Serial Port

2.8 Test Setup Block Diagram

Radiated Test

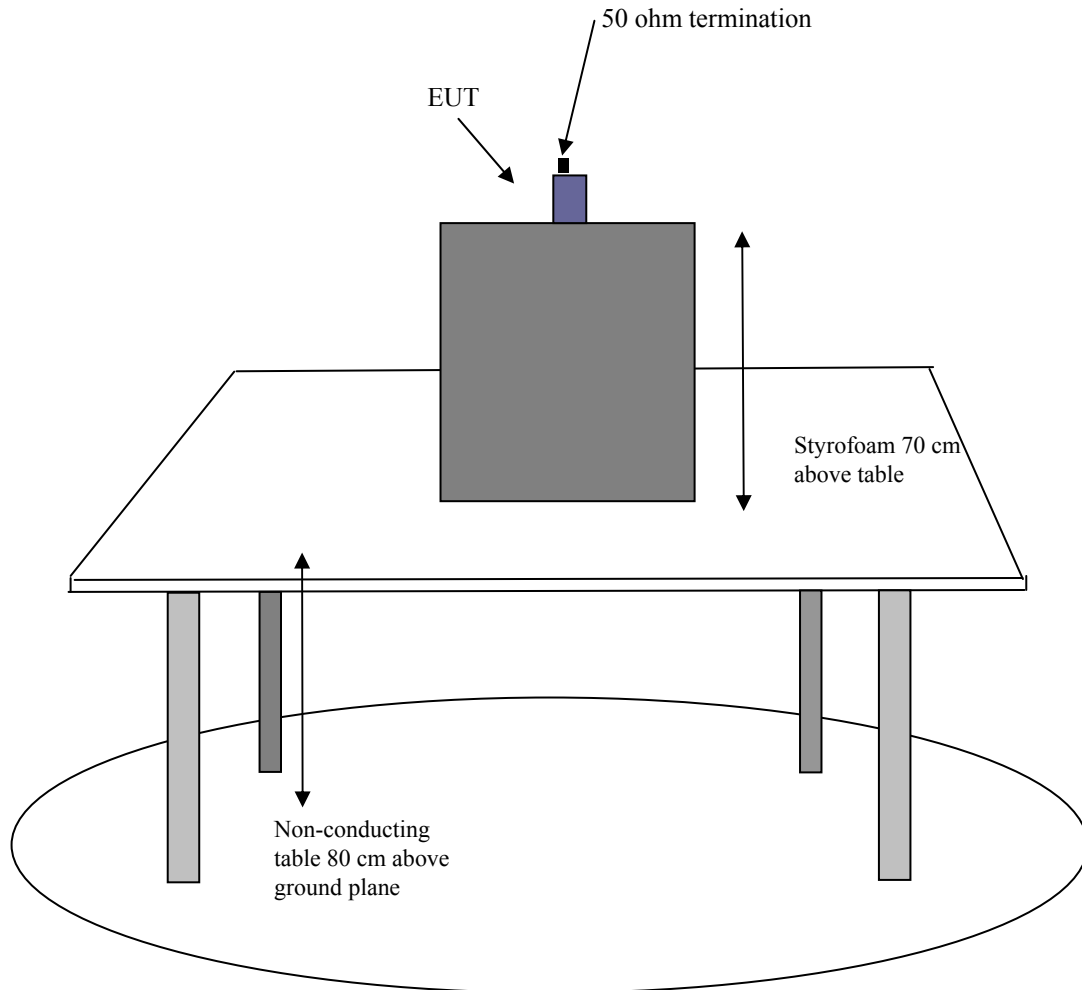

Conducted Test

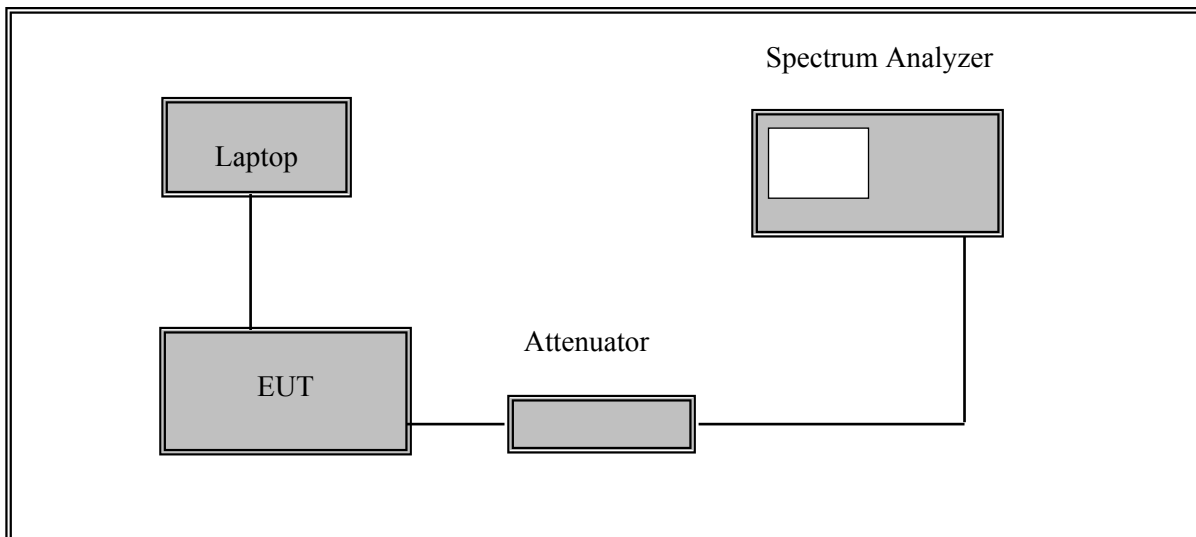

3 Summary of Test Results

FCC Rules	Description of Test	Result
FCC§1.1310, §2.1093	RF Exposure Information	Compliant ¹
FCC§2.1046, §90.205	RF Output Power	Compliant
FCC§2.1047, §90.207	Modulation Characteristics, Audio Frequency Response and Audio Filter Response	Compliant
FCC §2.1051, §90.221(d) FCC 11-63 (WT Docket No.11-69, ET Docket No. 09-234)	Spurious Emissions at Antenna Terminals	Compliant
FCC §2.1055, §90.213	Frequency Stability	N/A ²
FCC §2.1053, §90.221(d) FCC 11-63 (WT Docket No.11-69, ET Docket No. 09-234)	Field Strength of Spurious Radiation	Compliant
FCC §90.214	Transient Frequency Behavior	Compliant

Note 1: Refer to SAR report: R1108012-SAR from BACL

2: Refer to the original test report.

4 FCC §2.1093 - RF Exposure Information

4.1 Applicable Standards

FCC §2.1093

4.2 Result

This is a portable device which required SAR testing; refer to the separate SAR report No.: R1108012-SAR for detail results.

5 FCC §2.1046 & §90.205 – RF Output Power

5.1 Applicable Standard

According to FCC §2.1046, and §90.205, 450-470 MHz. (1) The maximum allowable station effective radiated power (ERP) is dependent upon the station's antenna HAAT and required service area and will be authorized in accordance with table 2.

5.2 Test Procedure

The RF output of the transmitter was connected to the input of the spectrum analyzer through sufficient attenuation.

5.3 Test Equipment List and Details

Manufacturer	Description	Model	Serial Number	Calibration Date
Agilent	Spectrum Analyzer	E4440A	MY44303352	2011-05-10

Statement of Traceability: BACL Corp. attests that all calibrations have been performed per the NVLAP requirements, traceable to the NIST.

5.4 Test Environmental Conditions

Temperature:	20°C
Relative Humidity:	40 %
ATM Pressure:	101.7 kPa

The testing was performed by Jack Liu on 2011-08-04 in RF site.

5.5 Test Results

Test Mode: Transmitting

Power Level	Frequency (MHz)	Conducted Output Power (dBm)	Conducted Output Power (Watt)
High	450.1	34.30	2.69
	460	34.47	2.80
	469.9	34.43	2.77
Low	450.1	14.51	0.028
	460	14.45	0.028
	469.9	14.63	0.029

6 FCC §2.1047 & §90.207 – Modulation Characteristic

6.1 Applicable Standard

FCC §2.1047 & §90.207:

- (a) Equipment which utilizes voice modulated communication shall show the frequency response of the audio modulating circuit over a range of 100 to 5000 Hz. for equipment which is required to have a low pass filter, the frequency response of the filter, or all of the circuitry installed between the modulation limited and the modulated stage shall be supplied.
- (b) Equipment which employs modulation limiting, a curve showing the percentage of modulation versus the modulation input voltage shall be supplied.

6.2 Test Procedure

Test Method: TIA/EIA-603-C 2.2.3

6.3 Test Results

Please refer to the hereinafter plots.

Transmitter Low Pass Filter

Type of Emission: 22K0Q7E, 22K0Q7D, 22K0Q7W, 22K0D7E, 22K0D7D, 22K0D7W
 The modulation used is $\pi/4$ -shifted Differential Quaternary Phase Shift Keying ($\pi/4$ -DQPSK), with a modulation rate of 18k symbol/sec. (36k bit/sec).

A root-raised-cosine filter (RRC) is used as transmitting and receiving filter in this digital communication system to perform matched filtering.

The combined response of two such filters is that of the raised-cosine filter.

The raised-cosine filter is a filter frequently used for pulse-shaping in digital modulation known for its ability to minimize intersymbol interference (ISI).

The access scheme is TDMA with 4 physical channels per carrier.

The following graph is the transfer function of the aforementioned filter.

Plot provided by manufacturer

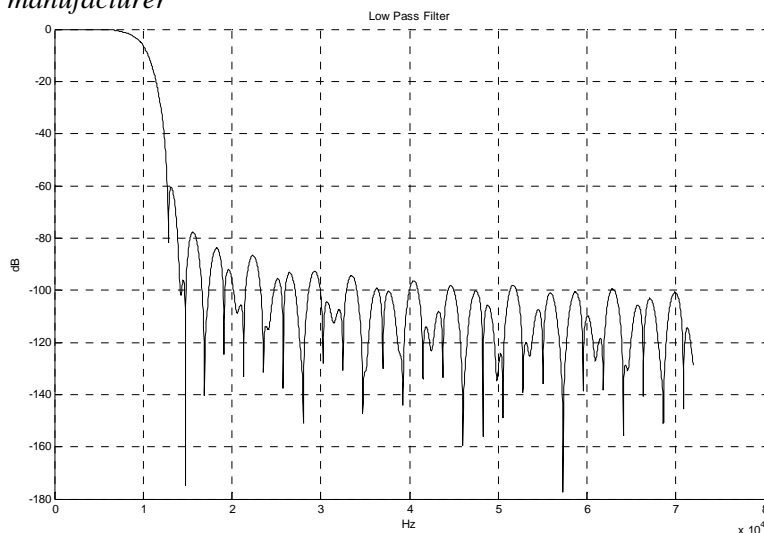

Audio Low Pass Filter

The modulation is limited by data characteristics and its filters.

In the previous section, the phase and quadrature branches (I and Q) are filtered with a root-raised-cosine filter (RRC) with a symbol rate of 18k symbol/sec. After that, the signal is pi/4 DQPSK modulated (see the plot in the previous section).

Signal processing is carried out using a ST Microelectronics STw5093 codec that contains the following low pass filter.

Plot provided by manufacturer

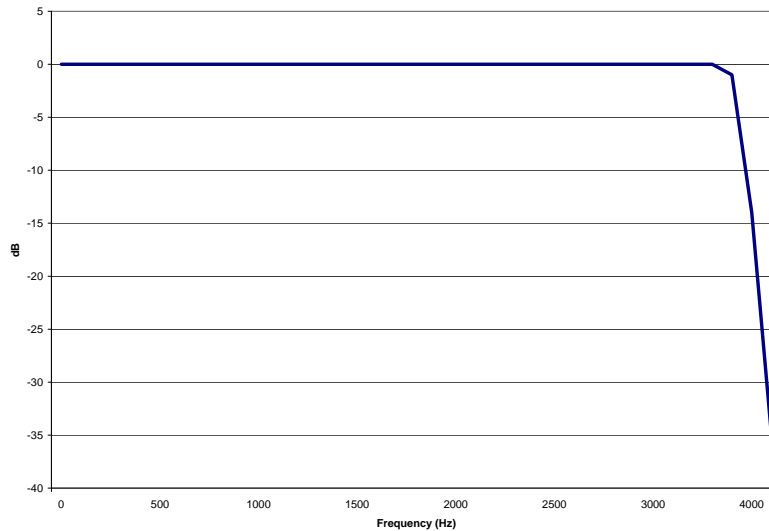

7 FCC §2.1051, §90.221(d) & FCC 11-63 - Spurious Emissions at Antenna Terminals

7.1 Applicable Standard

FCC 11-63 (WT Docket No.11-69, ET Docket No. 09-234)
FCC §2.1051 and §90.221(d)

On any frequency removed from the assigned frequency by more than 75 kHz, the attenuation of emission must be at least $43+10\log(P)$ dB.

7.2 Test Procedure

The RF output of the transceiver was connected to a spectrum analyzer through appropriate attenuation. The resolution bandwidth of the spectrum analyzer was set at 100 kHz. Sufficient scans were taken to show any out of band emissions up to 10th harmonic.

7.3 Test Equipment List and Details

Manufacturer	Description	Model	Serial Number	Calibration Date
Agilent	Spectrum Analyzer	E4440A	MY44303352	2011-05-10

Statement of Traceability: BACL Corp. attests that all calibrations have been performed per the NVLAP requirements, traceable to the NIST.

7.4 Test Environmental Conditions

Temperature:	20°C
Relative Humidity:	40 %
ATM Pressure:	101.7 kPa

The testing was performed by Jack Liu on 2011-08-04 in RF site.

7.5 Test Results

Please refer to the hereinafter plots.

450~470 MHz Band:

Low channel (450.1 MHz) High Power

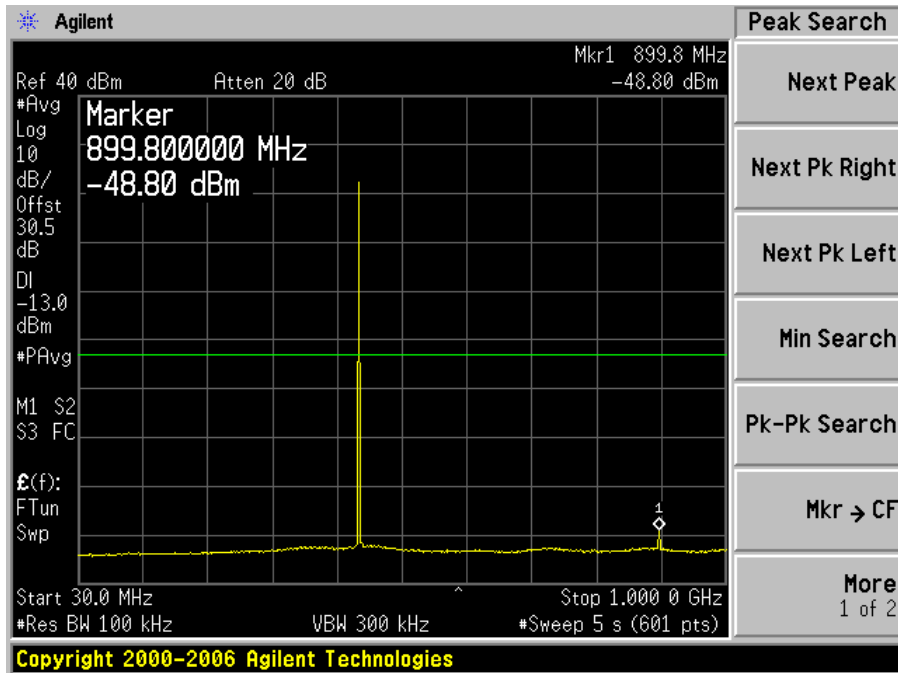

30 MHz to 1 GHz

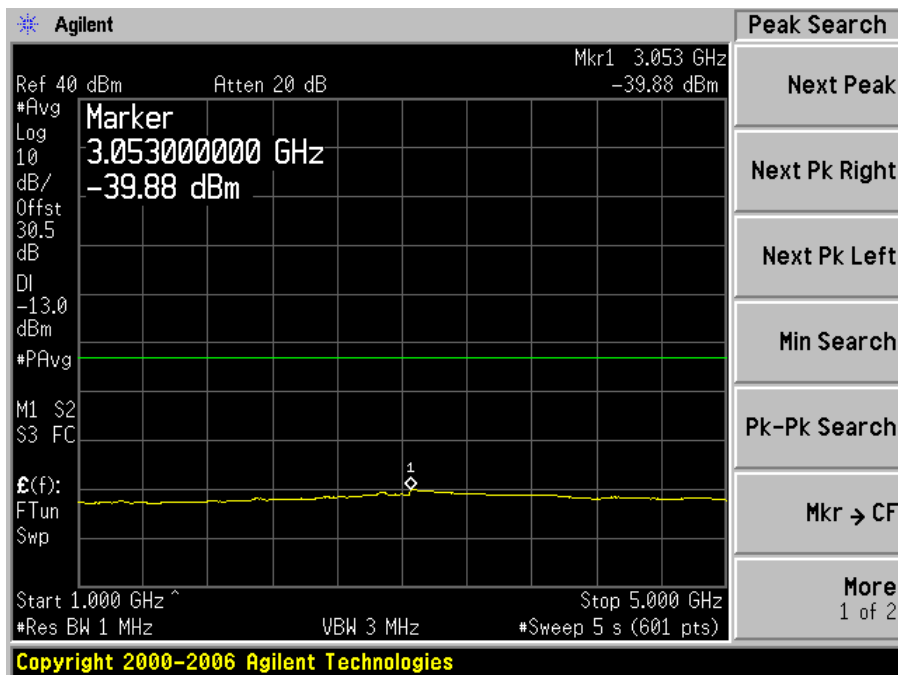

1 GHz to 5 GHz

Middle channel (460 MHz) High Power

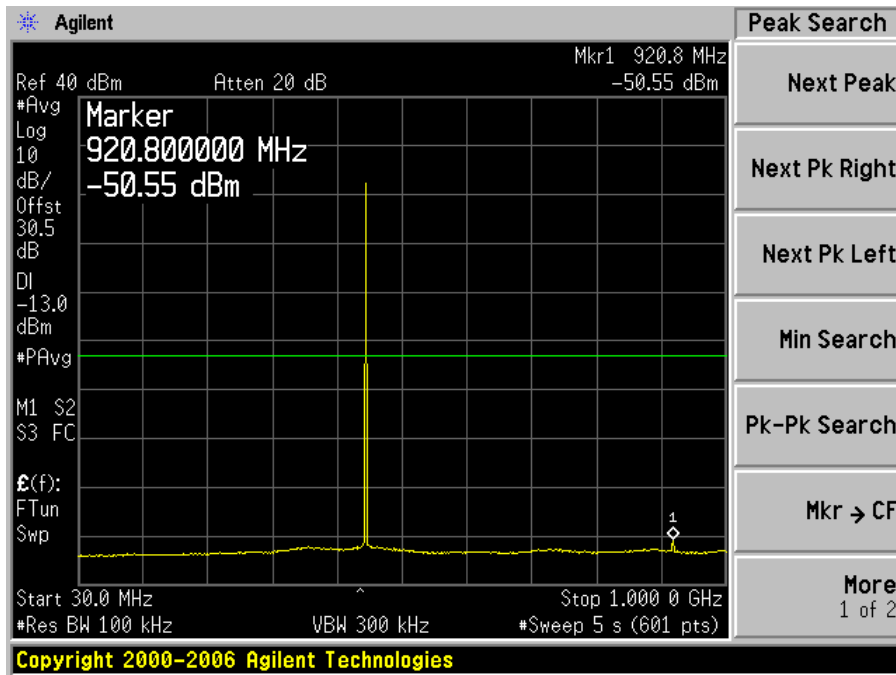

30 MHz to 1 GHz

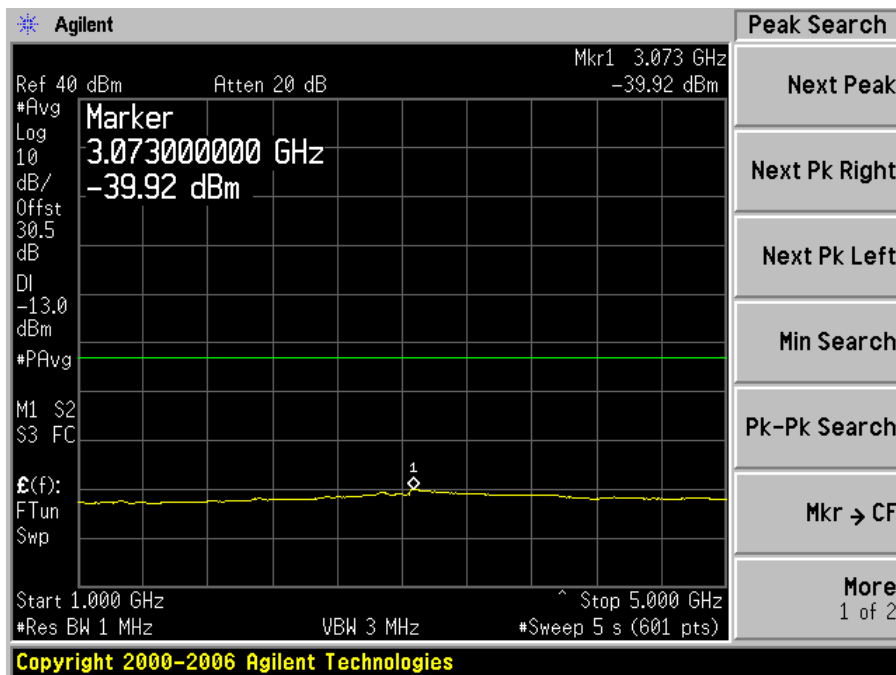

1 GHz to 5 GHz

High channel (469.9 MHz) High Power

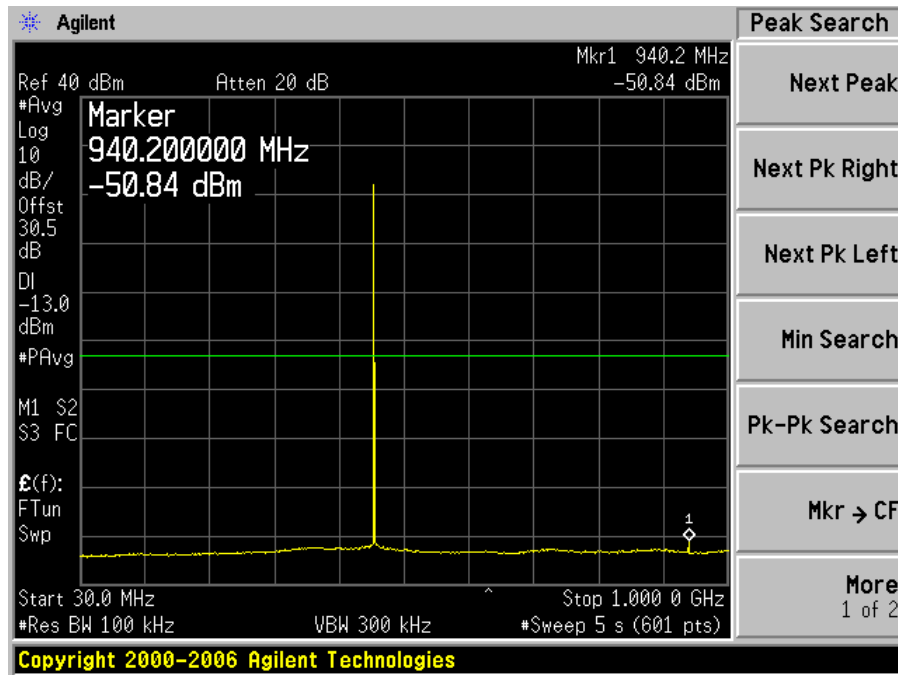

30 MHz to 1 GHz

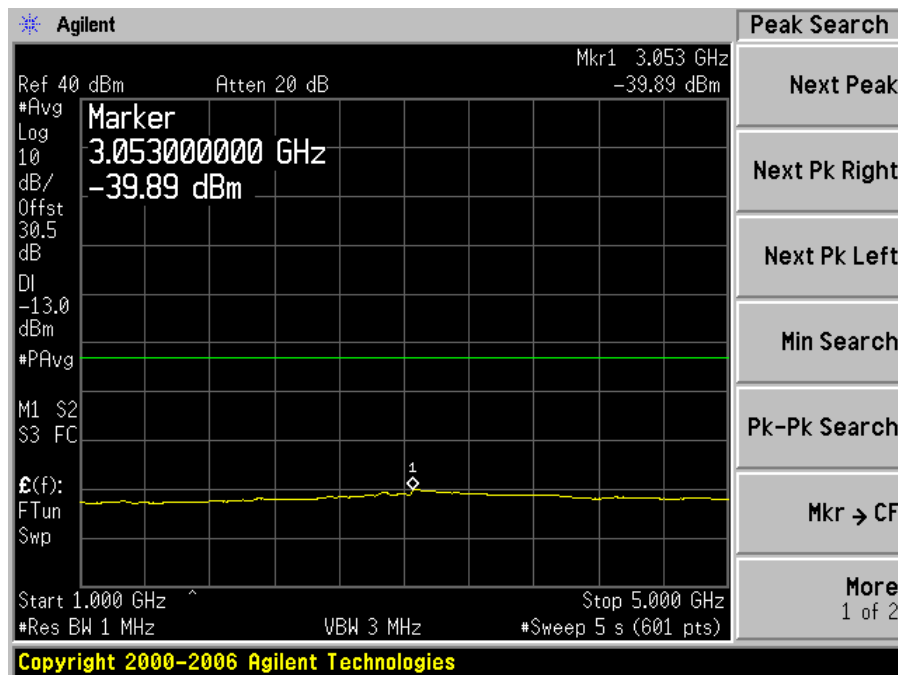

1 GHz to 5 GHz

8 FCC §2.1055 (d) & §90.213 - Frequency Stability

8.1 Applicable Standard

FCC §2.1055 (d), §90.213

(a) Unless noted elsewhere, transmitters used in the services governed by this part must have a minimum frequency stability as specified in the following table.

Minimum Frequency Stability

[Parts per million (ppm)]

Frequency range (MHz)	Fixed and base stations	Mobile stations	
		Over 2 watts output power	2 watts or less output power
Below 25	1,2,3 ₁₀₀	100	200
25-50	20	20	50
72-76	5		50
150-174	5,11 ₅	6 ₅	4,6 ₅₀
216-220	1.0		1.0
220-222 ¹²	0.1	1.5	1.5
421-512	7,11,14 _{2.5}	8 ₅	8 ₅
806-809	14 _{1.0}	1.5	1.5
809-824	14 _{1.5}	2.5	2.5
851-854	1.0	1.5	1.5
854-869	1.5	2.5	2.5
896-901	14 _{0.1}	1.5	1.5
902-928	2.5	2.5	2.5
902-928 ¹³	2.5	2.5	2.5
929-930	1.5		
935-940	0.1	1.5	1.5
1427-1435	9 ₃₀₀	300	300
Above 2450 ¹⁰			

¹⁴Control stations may operate with the frequency tolerance specified for associated mobile frequencies.

(b) For the purpose of determining the frequency stability limits, the power of a transmitter is considered to be the maximum rated output power as specified by the manufacturer.

8.2 Test Result

N/A, Please refer to the original test report.

9 FCC §2.1053, §90.221(d) & FCC 11-63 – Field Strength of Spurious Radiation

9.1 Applicable Standard

FCC 11-63 (WT Docket No.11-69, ET Docket No. 09-234)
FCC §2.1051 and §90.221(d)

On any frequency removed from the assigned frequency by more than 75 kHz, the attenuation of emission must be at least $43+10\log(P)$ dB.

9.2 Test Procedure

The transmitter was placed on a Styrofoam with wooden turntable, and it was normal transmitting with 50ohm termination which was also placed on the turntable.

The measurement antenna was placed at a distance of 3 meters from the EUT. During the tests, the antenna height and polarization as well as EUT azimuth were varied in order to identify the maximum level of emissions from the EUT. The test was performed by placing the EUT on 3-orthogonal axis.

The frequency range up to tenth harmonic of the fundamental frequency was investigated.

Remove the EUT and replace it with substitution antenna. A signal generator was connected to the substitution antenna by a non-radiating cable. The absolute levels of the spurious emissions were measured by the substitution.

Spurious emissions in dB = $10 \lg(\text{TXpwr in Watts}/0.001)$ – the absolute level

9.3 Test Equipment List and Details

Manufacturer	Description	Model	Serial Number	Calibration Date
Rohde & Schwarz	EMI Test Receiver	ESCI 1166.5950K03	100337	2011-03-21
Agilent	Spectrum Analyzer	E4440A	MY44303352	2011-05-10
Sunol Science Corp	System Controller	SC99V	122303-1	N/R
Sunol Science Corp	Combination Antenna	JB3	A0020106-3	2011-06-29
A.R.A Inc	Horn antenna	DRG-1181A	1132	2010-11-29
Hewlett Packard	Pre amplifier	8447D	2944A06639	2011-06-09
Mini-Circuits	Pre Amplifier	ZVA-183-S	570400946	2011-05-09

Statement of Traceability: BACL attests that all calibrations have been performed per the NVLAP requirements, traceable to NIST.

9.4 Test Environmental Conditions

Temperature:	22~24 °C
Relative Humidity:	38~40 %
ATM Pressure:	101.6~101.8kPa

The testing was performed by Jack Liu on 2011-08-08~2011-08-10 in chamber 3.

9.5 Test Results

High Power Middle Channel (460 MHz)

Test Mode: Transmission Using substitution method

Indicated		Turntable Azimuth degrees	Test Antenna		Substituted					Limit (dBm)	Margin (dB)
Freq. (MHz)	Amp. (dBuV)		Height (cm)	Polar (H/V)	Freq. (MHz)	Level (dBm)	Antenna Cord. (dBi)	Cable Loss (dB)	Absolute Level (dBm)		
920	37.81	235	138	V	920	-52.9	0	1	-53.9	-13	-40.9
920	33.14	207	150	H	920	-59.61	0	1	-60.61	-13	-47.61
1380	57.06	192	113	V	1380	-46.43	8.1	1.4	-39.73	-13	-26.73
1380	50.39	213	162	H	1380	-52.46	8.1	1.4	-45.76	-13	-32.76

10 FCC §90.214 - Transient Frequency Behavior

10.1 Applicable Standard

FCC §90.214: Transmitters designed to operate in the 150–174 MHz and 421–512 MHz frequency bands must maintain transient frequencies within the maximum frequency difference limits during the time intervals indicated:

Time intervals ^{1,2}	Maximum frequency difference ³	All equipment
		421 to 512 MHz
Transient Frequency Behavior for Equipment Designed to Operate on 25 kHz Channels		
t_1^4	± 25.0 kHz	10.0 ms
t_2	± 12.5 kHz	25.0 ms
t_3^4	± 25.0 kHz	10.0 ms
Transient Frequency Behavior for Equipment Designed to Operate on 12.5 kHz Channels		
t_1^4	± 12.5 kHz	10.0 ms
t_2	± 6.25 kHz	25.0 ms
t_3^4	± 12.5 kHz	10.0 ms

10.2 Test Procedure

TIA/EIA-603-C 2.2.19

10.3 Test Setup Block Diagram

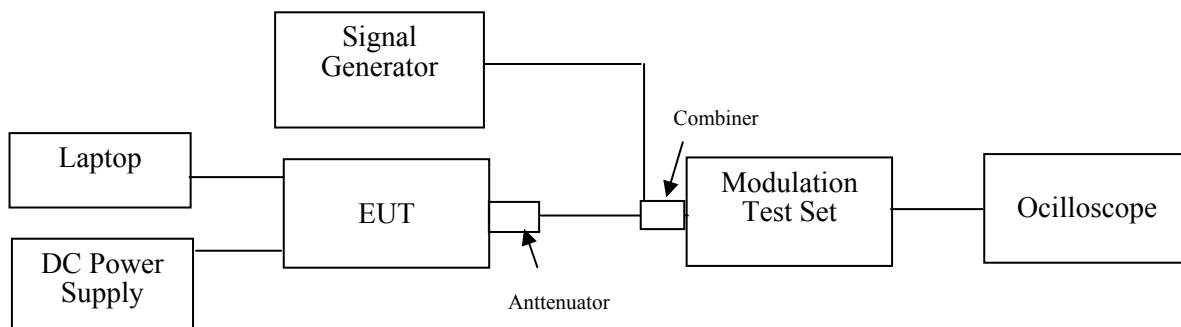

10.4 Test Equipment List and Details

Manufacturer	Description	Model	Serial Number	Calibration Date
Tektronix	Digital Phosphor Oscilloscope	TDS7104	B020557	2011-06-09
Agilent	Generator, Signal	E4438C	MY45091309	2011-04-28
Agilent	Spectrum Analyzer	E4440A	MY44303352	2011-05-10
HP	Test Set, RF Communications	8920A	3438A05338	2010-05-18*

Statement of Traceability: BACL Corp. attests that all calibrations have been performed per the NVLAP requirements, traceable to the NIST

* Based on a two year calibration cycle

10.5 Test Environmental Conditions

Temperature:	24 °C
Relative Humidity:	40 %
ATM Pressure:	101.6 kPa

The testing was performed by Jack Liu on 2011-08-12 in RF site.

10.6 Test Results

Please refer to the following plots.

450~470 MHz Band

Powering Up

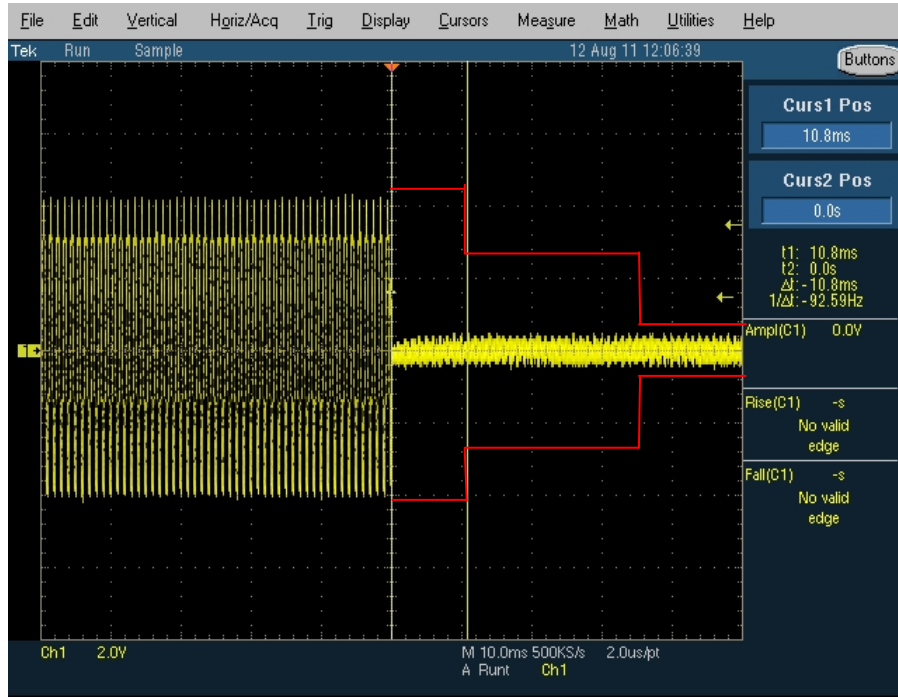

Powering Down

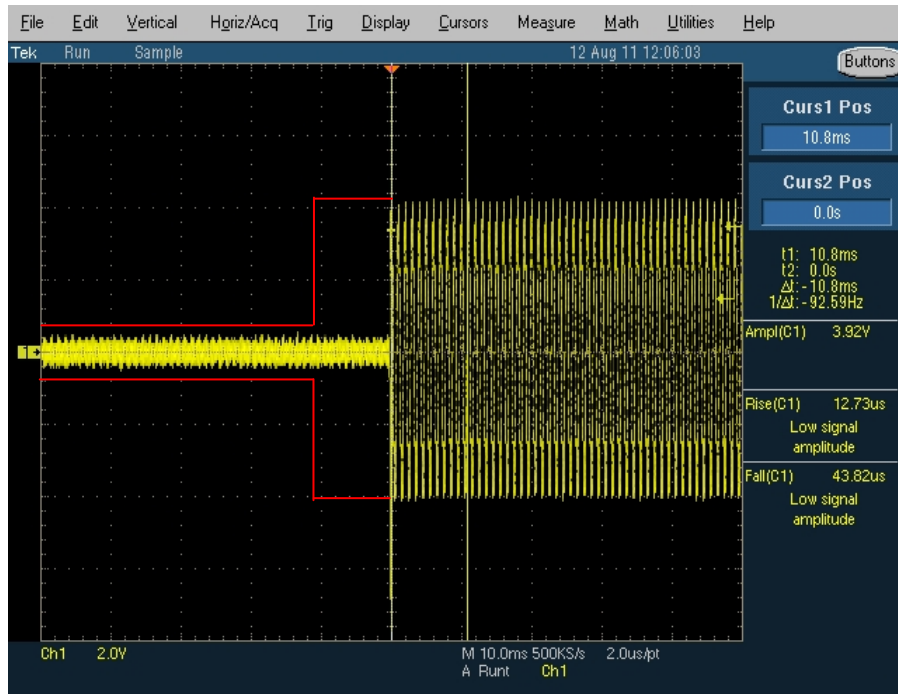

11 FCC 11-63 – Adjacent Channel Power and Wideband Noise

11.1 Applicable Standard

Pursuant to ET Docket No. 09-234 § 24, measurements for Adjacent Channel Power and Wideband Noise according to ETSI EN 300 392-2 must be performed instead of FCC Part 90 Sections 90.209 and 90.210.

According to ETSI EN 300 392-2 v3.4.1 (2010-08), limits for Adjacent Power Levels and Wideband Noise are:

Section 6.4.2.2. Emission during the useful part of burst.

Table 6.4: Maximum adjacent power levels for frequencies below 700 MHz

Frequency offset	Maximum level for MS power classes 4 (1W) and 4L (0.56W).	Maximum level for other power classes
25 kHz	-55 dBc	-60 dBc
50 kHz	-70 dBc	-70 dBc
75 kHz	-70 dBc	-70 dBc

Table 6.5: Maximum adjacent power levels for frequencies above 700 MHz

Frequency offset	Maximum Level
25 kHz	-55 dBc
50 kHz	-65 dBc
75 kHz	-65 dBc (see note)

Note: A level of -70dBc shall apply for:
- BS Power Classes 1,2 and 3 and for MS Power Classes 1 (30 W) and 1L(17.5 W)

Section 6.4.2.3 Unwanted emissions far from the carrier → b) Wideband Noise

Table 6.6: Wideband noise limits for frequencies below 700 MHz

Frequency offset	Maximum wideband noise level		
	MS nominal power <= 1W (class 4)	MS nominal power level =1.8 W or 3W (class 3L or 3)	MS nominal power level >=5.6W (class 2L) BS all classes
100 kHz to 250 kHz	-75 dBc	-78 dBc	-80 dBc
250 kHz to 500 kHz	-80 dBc	-83 dBc	-85 dBc
500 kHz to frb	-80 dBc	-85 dBc	-90 dBc
> frb	-100 dBc	-100 dBc	-100 dBc

Note: frb denotes the frequency offset corresponding to the near edge of the receive band or 5 MHz (10 MHz for frequencies above 520 MHz) whichever is greater.

Table 6.7: Wideband noise limits for frequencies above 700 MHz

Frequency offset	Maximum wideband noise level		
	MS nominal power <= 1W (class 4)	MS nominal power level =1.8 W or 3W (class 3L or 3) BS Nominal Power Levels <=10	MS and BS nominal power levels from 15 W to 40 W
100 kHz to 250 kHz	-74 dBc	-74 dBc	-80 dBc
250 kHz to 500 kHz	-80 dBc	-80 dBc	-85 dBc
500 kHz to frb	-80 dBc	-85 dBc	-90 dBc
> frb	-100 dBc	-100 dBc	-100 dBc

Note: frb denotes the frequency offset corresponding to the near edge of the receive band or 10 MHz whichever is greater.

All levels in tables 6.6 and 6.7 are expressed in dBc relative to the actual transmitted power level, and in any case no limit tighter than -55 dBm for offsets < frb or -70 dBm for offsets > frb shall apply

11.2 Test Setup Block Diagram

Adjacent Channel Power test set

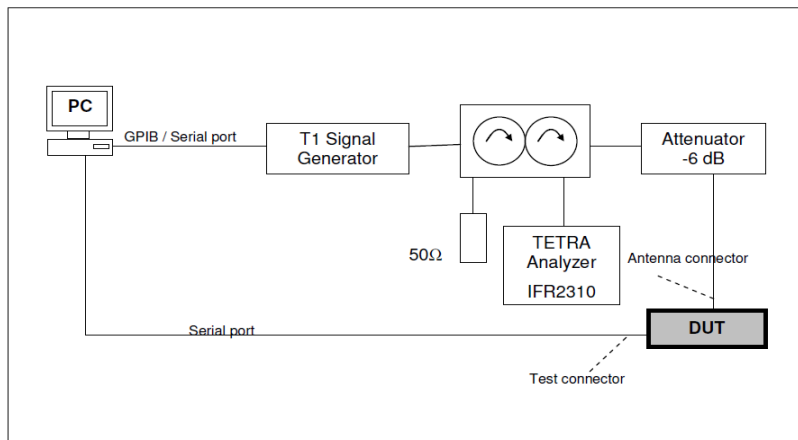

Wideband Noise test set

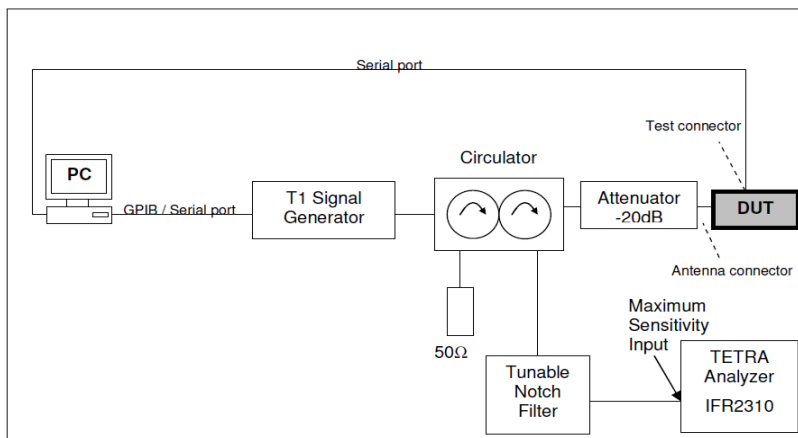

11.3 Test Equipment List and Details

Manufacturer	Description	Model	Serial Number	Calibration Date
Aeroflex	TETRA Signal Analyzer	IFR2310	231001/122	2011-03-12
Telonic Berkeley	Notch Filter	TTR 375-3EE	97022-2	N/A
BIRD	20 dB Attenuator	100-SA-FFN-20	0348	N/A
BIRD	06 dB Attenuator	100-SA-FFN-06	0347	N/A
Agilent	RF Signal Generator	E4438C	MY45093571	2011-03-12
AFL	Circulator	450/470	22173	N/A
AFL	50 ohms Load	N/A	7092	N/A

11.4 Test Environmental Conditions

Temperature:	20 °C
Relative Humidity:	46 %
ATM Pressure:	101.5kPa

The testing was performed by Pedro Peña on 2011-July at Teltronic S.A.U.

11.5 Test Results

Please refer to the following tables and plots provided by manufacturer

ADJACENT CHANNEL POWER (ACCORDING TO ETSI EN 300 392-2) -- ET Docket No. 09-234 (Waiver)					
A) DURING THE USEFUL PART OF THE BURST DUE TO MODULATION					
	Channel 0	Channel 1	Channel 2	Limit Values	
	450 MHz	460 MHz	470 MHz		
35 dBm (3 W) - 75 kHz	-76.55	-76.28	-74.93	-70	dBc
- 50 kHz	-73.33	-73.04	-72	-70	dBc
- 25 kHz	-63.58	-63.48	-63.36	-60	dBc
+ 25 kHz	-62.47	-62.33	-62.31	-60	dBc
+ 50 kHz	-72.28	-72.16	-71.47	-70	dBc
+ 75 kHz	-75.24	-74.98	-74.57	-70	dBc
15 dBm (30mW) - 75 kHz	-53.65	-53.65	-53.61	-36	dBm
- 50 kHz	-53.35	-53.4	-53.37	-36	dBm
- 25 kHz	-48.35	-48.5	-48.64	-36	dBm
+ 25 kHz	-48.98	-49.01	-49.19	-36	dBm
+ 50 kHz	-53.15	-53.22	-53.16	-36	dBm
+ 75 kHz	-52.19	-52.19	-52.18	-36	dBm

WIDEBAND NOISE (ACCORDING TO ETSI EN 300 392-2) -- ET Docket N° 09-234 (Waiver)					
	Channel 0	Channel 1	Channel 2	Limit Values	
	450 MHz	460 MHz	470 MHz		
<i>fTX</i> - 5,0375 MHz (*)	-102.82	-103.22	-103.39	-100	dBc
<i>fTX</i> - 512,5 kHz	-90.74	-91.19	-91.51	-85	dBc
<i>fTX</i> - 262,5 kHz	-89.59	-89.8	-89.72	-83	dBc
<i>fTX</i> - 112,5 kHz	-85.34	-85.26	-84.99	-78	dBc
<i>fTX</i> + 112,5 kHz	-85.72	-85.45	-84.93	-78	dBc
<i>fTX</i> + 262,5 kHz	-88.21	-87.9	-88.75	-83	dBc
<i>fTX</i> + 512,5 kHz	-88.59	-88.9	-90.13	-85	dBc
<i>fTX</i> + 5,0375 MHz (*)	-102.29	-103	-104.15	-100	dBc

(*) ETSI EN 300 394-1 section 8.5 states: "If a discrete spurious lies in one of these bands, then the closest discrete spurious free frequency which is higher shall be chosen".

Plots :
High Power, Low Channel 450MHz
Adjacent Channel Power (ETSI EN 300 392-2)

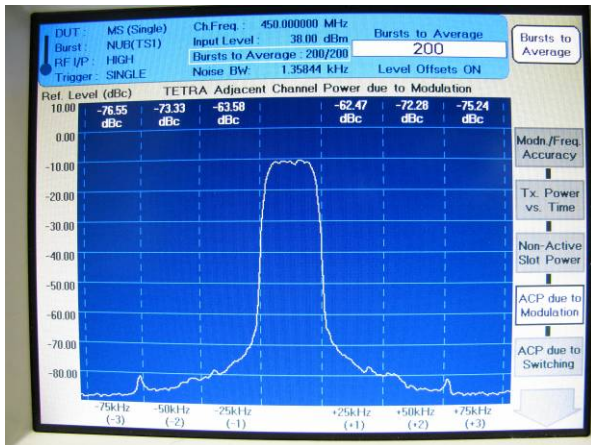

Plots :
High Power, Middle Channel 460MHz
Adjacent Channel Power (ETSI EN 300 392-2)

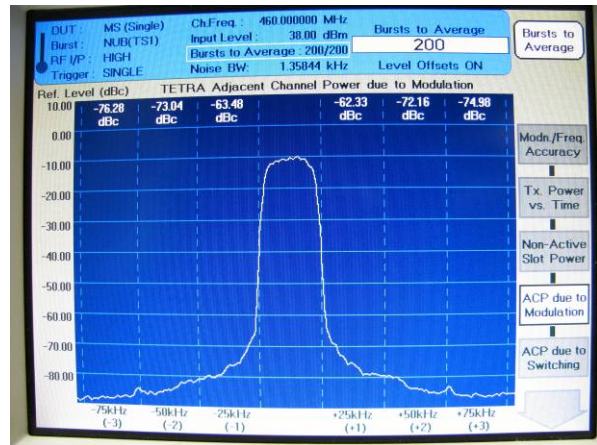

Plots :
High Power, High Channel 470MHz
Adjacent Channel Power (ETSI EN 300 392-2)

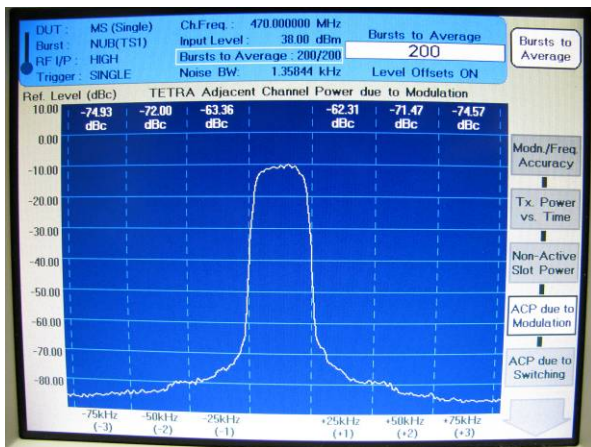

Plots :
High Power, Low Channel 450MHz
Wideband Noise (ETSI EN 300 392-2)

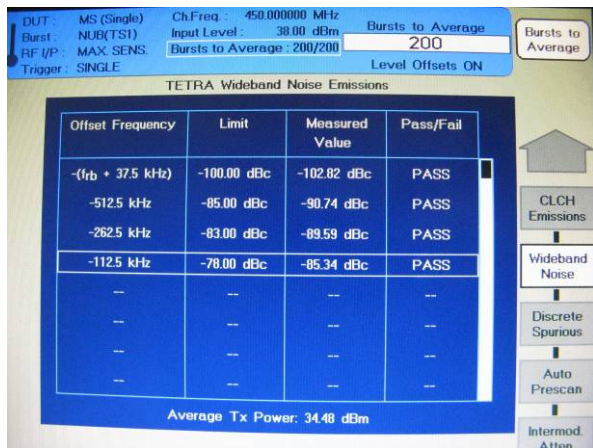

Plots :
High Power, Low Channel 450MHz
Wideband Noise (ETSI EN 300 392-2)

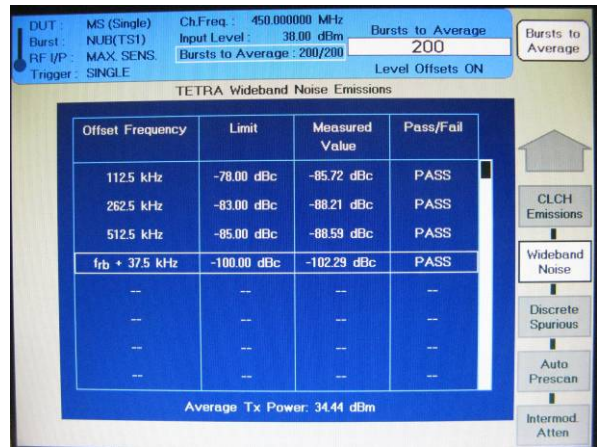

Plots :
High Power, Middle Channel 460MHz
Wideband Noise (ETSI EN 300 392-2)

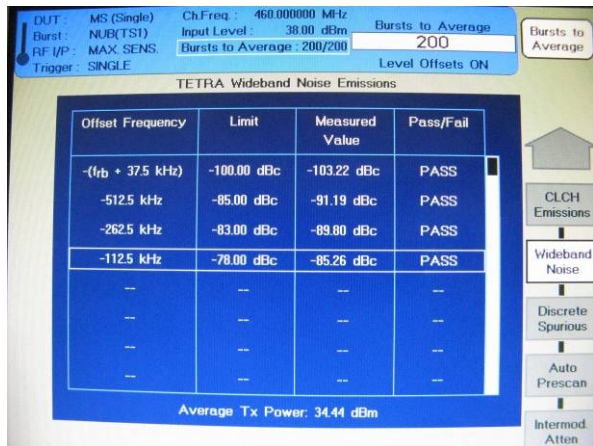

Plots :
High Power, Middle Channel 460MHz
Wideband Noise (ETSI EN 300 392-2)

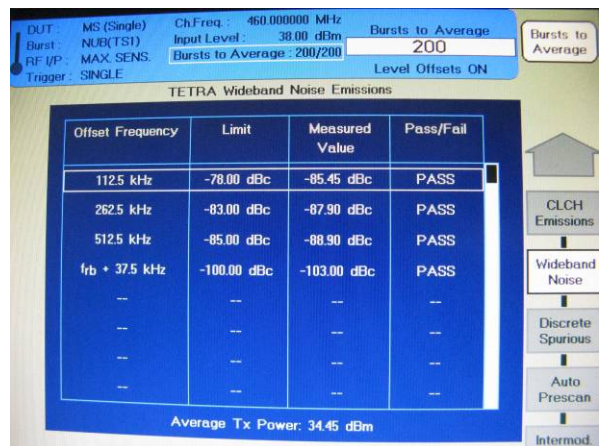

Plots :
 High Power, High Channel 470MHz
 Wideband Noise (ETSI EN 300 392-2)

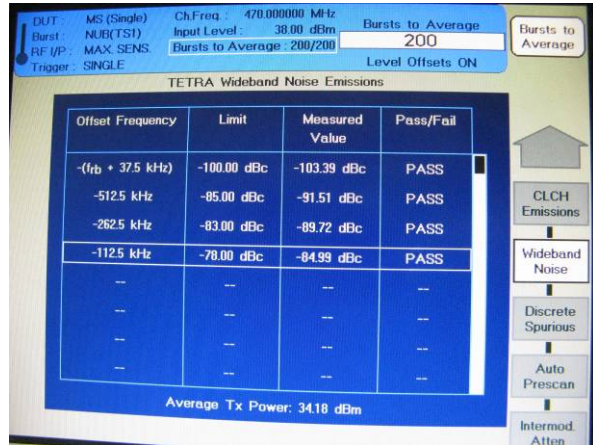

Plots :
 High Power, High Channel 470MHz
 Wideband Noise (ETSI EN 300 392-2)

