

TECHNICAL DESCRIPTION**PowerTrunk-T****TETRA MBS UNIT. INSTALLATION GUIDE**

Document	F067646PT_2801
Product	PowerTrunk-T
Date	June 2018

**DECLARATION OF CONFORMITY**

Hereby, Teltronic S.A.U. declares that the radio equipment type Mast-mounted Base Station MBS Unit is in compliance with Directive 2014/53/EU.

The full text of the EU declaration of conformity is available through the technical assistance service at the Internet address: <http://www.teltronic.es/en/soporte/>

**USE RESTRICTIONS**

This radio equipment is subject to restrictions on putting into service or to requirements for authorization of use in the following countries:



BE	BG	CZ	CH	DK	DE
EE	IE	EL	ES	FR	HR
IT	IS	CY	LI	LV	LT
LU	HU	MT	NL	NO	AT
PL	PT	RO	SI	SK	FI
SE	UK				

This equipment can be used in all Member States of the European Union once the corresponding administrative license is obtained.

***WASTE MANAGEMENT***



The symbol means that the product must be taken to separate collection at the product end-of life. Do not dispose of these products as unsorted municipal waste.

*PowerTrunk Inc. is the subsidiary of Teltronic S.A.U. responsible for business development, distribution and customer support for Teltronic's Land Mobile Radio products in North America. The company is headquartered in New Jersey. Teltronic S.A.U. distributes the same products for Land Mobile Radio under different trademarks and brand names in other regions of the world.*

**Disclaimer**

*Although every reasonable effort has been made to ensure the accuracy of the information contained herein and in any other referred document, this should not be construed as a commitment on the part of Teltronic S.A.U. and/or PowerTrunk Inc., and the liability of Teltronic S.A.U. and/or PowerTrunk Inc. for any errors and omissions shall be limited to the correction of such errors and omissions. Teltronic S.A.U. and/or PowerTrunk Inc. welcomes any comment as a way to improve any delivered documentation.*

*The information contained herein has been prepared for the use of appropriately trained personnel, and it is intended for the purpose of the agreement under which the information is submitted. Any party using or relying upon this information assumes full responsibility for such use and in no event shall Teltronic S.A.U. and/or PowerTrunk Inc. be liable to anyone for special, collateral, incidental, or consequential damages in connection with or arising out of the use of this information.*

*The information or statements given in these documents regarding the suitability, capacity or performance of the mentioned hardware or software products cannot be considered binding but shall be defined in the agreement made between Teltronic S.A.U. and/or PowerTrunk Inc. and the customer.*

*Teltronic S.A.U. and/or PowerTrunk Inc. reserves the right to revise these documents and to make changes to their content at any time, without prior notification.*

**Copyright**

*No part of the information contained herein and the other referred documents may be copied, distributed or transmitted by any means to any other party without prior written permission of Teltronic S.A.U. and/or PowerTrunk Inc. The distribution of this document may be also covered by NDA (non-disclosure agreement) between Teltronic S.A.U. and/or PowerTrunk Inc. and the receiver.*

*Please also note that part of these contents even may be covered by patent rights.*

*This document, the referred documents and the described product are considered protected by copyright according to the applicable laws.*

*PowerTrunk and the PowerTrunk logo are registered trademarks of Teltronic S.A.U.*

*Copyright © PowerTrunk Inc. All rights reserved*

## TABLE OF CONTENTS

<b>1. INTRODUCTION</b>	<b>5</b>
<b>2. UNPACKING AND CHECKING</b>	<b>6</b>
<b>3. PREVIOUS CONSIDERATIONS</b>	<b>7</b>
<b>4. INFORMATION ON SAFETY AND ELECTROMAGNETIC COMPATIBILITY</b>	<b>8</b>
4.1 GENERAL CONSIDERATIONS ABOUT SAFETY .....	8
4.2 OPERATION AND EXPOSURE TO RF ENERGY .....	9
4.3 IMPORTANT SAFETY NOTES ABOUT THE ANTENNA.....	10
4.4 ELECTROMAGNETIC COMPATIBILITY REGULATORY INFORMATION (FCC AND ISSED) .....	11
4.5 UL / SAFETY CERTIFICATIONS .....	12
4.6 EMC, SAFETY AND RF EXPOSURE STANDARDS .....	12
4.7 MECHANICAL AND ENVIRONMENTAL STANDARDS .....	13
4.7.1 STANDARDS CENELEC .....	13
4.7.2 STANDARDS MIL-STD 810G .....	14
<b>5. EQUIPMENT DESCRIPTION</b>	<b>15</b>
5.1 VIEW.....	15
5.2 CONNECTORS .....	16
5.3 VISUAL INDICATORS .....	18
5.4 DIMENSIONS .....	19
<b>6. INSTALLATION GUIDE</b>	<b>20</b>
6.1 NECESSARY EQUIPMENT .....	21
6.2 BASIC PRE-CONFIGURATION.....	23
6.3 INSTALLATION .....	24
6.3.1 MAST/POLE INSTALLATION .....	26
6.3.1.1 MAST/POLE SELECTION .....	26
6.3.1.2 MAST/POLE MOUNTING INSTRUCTIONS .....	28
6.3.2 WALL INSTALLATION.....	31
6.3.3 PBS ACCESSORY INSTALLATION .....	34
6.3.3.1 WORKING POSITIONS .....	37
6.3.4 ANTI-VANDAL KIT INSTALLATION.....	39
6.3.5 REQUIREMENTS TO CONSIDER DURING THE ANTENNA INSTALLATION .....	40
6.3.6 CONNECTIONS .....	42
6.3.6.1 SUPPORTED CONFIGURATIONS .....	43
6.3.6.2 CONNECTION OF THE EXTERNAL POWER SUPPLY .....	53
6.3.6.3 ANTENNA CONNECTION .....	56
6.3.6.4 EXTERNAL ETHERNET CONNECTION .....	57
6.3.7 CONNECTING / DISCONNECTING THE MBS AC MAINS SUPPLY .....	58
6.3.8 CONNECTING / DISCONNECTING THE MBS FROM THE DC SUPPLY .....	59
<b>7. START UP/CONFIGURATION/VERIFICATION</b>	<b>60</b>
<b>8. INCIDENTS</b>	<b>61</b>
8.1 INTERFERENCE AT MBS UNIT .....	61
8.2 OVER VOLTAGE PROTECTION.....	62

## 1. INTRODUCTION

The MBS Units are the outdoor modules that make up a Mast Mounted Base Station (MBS). They are independent units that can be interconnected with each other to increase the base station capacity. A MBS consists of a maximum of two MBS Units.

The following table displays all the MBS Unit available models, together with their respective frequency band and maximum RF transmitted power.

MBS Unit:	Frequency band:	Nominal transmitter output power:	Maximum transmitter output power:
D148H01PT	350-370 MHz	10 W	12.6 W
D148P01PT	380-400 MHz	10 W	12.6 W
D148701PT	409-430 MHz	10 W	12.6 W
D148101PT	425-470 MHz	10 W	12.6 W
D148K01PT	763-806 MHz	10 W	12.6 W
D148N01PT	806-870 MHz	10 W	12.6 W

This manual is common to all the equipment models, including all their options and accessories.

The proper operation of any electronic device depends on its correct use. Therefore, it is recommended to follow the instructions showed in this manual.

## 2. UNPACKING AND CHECKING

The equipment is supplied with all the necessary materials for the installation, either on a mast, on a wall or over the PBS Accessory:

- ❑ MBS Unit includes the followings items
  - One power connector.
  - One Ethernet connector
  - RF super-flexible wire N-Male – N-Male.
- ❑ Brackets for the installation.

Besides, in some types of installation, as detailed below, it is necessary an additional material that is NOT supplied with the equipment.

**IMPORTANT:** If any of the necessary elements to carry out the installation process described in this guide is missing or damaged, please contact your supplier.

### 3. PREVIOUS CONSIDERATIONS

This manual contains information about instructions for installation, maintenance and use. Read the following pages before using this equipment.

It is not advisable to switch on the equipment without having previously connected the antenna otherwise irreparable damage could be. It is important to use an antenna adjusted to the work frequency.

## 4. INFORMATION ON SAFETY AND ELECTROMAGNETIC COMPATIBILITY

### 4.1 GENERAL CONSIDERATIONS ABOUT SAFETY

#### PLEASE READ THESE INSTRUCTIONS CAREFULLY FOR IMPORTANT INFORMATION ABOUT SAFELY OPERATING THIS PRODUCT

Most electronic equipment are susceptible to electromagnetic interference if they are not duly protected. If the MBS Unit is placed near unprotected electronic devices, they may malfunction.

Only cables that fulfil the characteristics specified in this document must be used. Communication cables must be shielded and earthed at both ends.

Take care when handling the MBS Unit. It has edges, which may cut if handled incorrectly.

Do not attempt to dismantle this product. Servicing and repairs to this product must be performed by trained service technicians at PowerTrunk approved service centres.

PowerTrunk has not approved any changes or modifications to this device by the user. Any changes or modifications could void the user's authority to operate the equipment.

Only fit an approved accessory. If a non-approved accessory is fitted, it may compromise the product safety ratings and may void any product warranty.

Maintenance and repair of this device must be carried out by qualified personnel only.



## 4.2 OPERATION AND EXPOSURE TO RF ENERGY

It is the responsibility of the person operating the product to ensure that it is operated safely at all times, and that local laws and regulations governing the usage of Radio Frequency (RF) wireless devices are observed. Obey all signs and instructions relating to the usage to RF wireless devices.

PowerTrunk designs and manufactures products to meet strict guidelines and international standards relating to Radio Frequency (RF) energy and the potential health risks associated with using RF wireless devices. If you have any concerns relating to long term health risks associated with using RF wireless devices, you should obtain advice from your employer.

### FCC and ISED radiation exposure statement

This radio is intended for use in occupational/controlled applications where users have been made aware of the potential risks for exposure and can exercise control over their exposure. This product is not authorised for general population, consumer or similar use. This transmitter must not be co-located or operated in conjunction with any other antenna or transmitter.

This equipment complies with FCC and ISED radiation exposure limits set forth for an uncontrolled environment. The antenna should be installed and operated with minimum distance of 2 metres (2.19 yards) between the radiator and your body. This transmitter must not be co-located or operating in conjunction with any other antenna or transmitter.

### FCC compliance labelling on RF Exposure

The following compliance product labelling can be found in a conspicuous location of the MBS Unit radio for North America market:

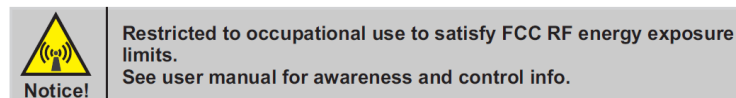

### FCC notice on operating the device

The device may contain functions that are not operational in U.S Territories except as noted in the certification filing. Devices may be restricted in frequency by the FCC TCB Grant. Please refer to it for allowed frequency ranges. The TCB Grant may have extended frequencies as noted in the certification filing and Section 2.927(b) may apply to the authorisation. The device complies with 47 CFR Part 90.203 (e), in that the operator cannot directly program the transmit frequencies using the normal accessible external controls. All instructions detailed in this manual must be followed in order to ensure compliance with RF exposure limits.

Failure to observe these restrictions may result in exceeding the FCC RF exposure limits.

### ISED Canada information on RF Exposure

The Government of Canada provides further information about RF Exposure by means of official publications that are available on the following website:

<http://www.ic.gc.ca/eic/site/smt-gst.nsf/eng/sf01904.html>

### 4.3 IMPORTANT SAFETY NOTES ABOUT THE ANTENNA

This radio has been approved by FCC and ISED to operate with the antenna types listed below with the maximum permissible gain indicated. Antenna types not included in this list, having a gain greater than the maximum gain indicated for that type, are strictly prohibited for use with this device.

MODEL	CERTIFICATION NUMBER	TYPE OF ANTENNA	MAX.GAIN
MBS Unit –7 (409-430 MHz)	FCC ID: WT7PTRNKTMS410 IC: 8624A-PTMBS410	Vertically polarised panel antenna	11.0 dBi
		Cross-polarised panel antenna	15.0 dBi
		Vertically polarised collinear antenna	11.15 dBi

MODEL	CERTIFICATION NUMBER	TYPE OF ANTENNA	MAX.GAIN
MBS Unit –1 (425-470 MHz)	FCC ID: WT7PTMBS450B IC: 8624A-PTMBS450B	Vertically polarised panel antenna	11.0 dBi
		Cross-polarised panel antenna	15.0 dBi
		Vertically polarised collinear antenna	11.15 dBi

MODEL	CERTIFICATION NUMBER	TYPE OF ANTENNA	MAX.GAIN
MBS Unit –K (763-806 MHz)	FCC ID: WT7PTMBS760B IC: 8624A-PTMBS760B	Vertically polarised panel antenna	16.5 dBi
		Cross-polarised panel antenna	18.0 dBi
		Vertically polarised collinear antenna	11.15 dBi

MODEL	CERTIFICATION NUMBER	TYPE OF ANTENNA	MAX.GAIN
MBS Unit –N (806-870 MHz)	FCC ID: WT7PTMBS800B IC: 8624A-PTMBS800B	Vertically polarised panel antenna	16.5 dBi
		Cross-polarised panel antenna	18.0 dBi
		Vertically polarised collinear antenna	11.15 dBi

Only use PowerTrunk approved antennas with this product. The use of non-approved antennas may damage the product, will result in the non-compliance with regulatory requirements, will compromise the product safety ratings, will reduce the length of operating time and will invalidate the product warranty.

Once the antenna has been installed, follow the guidelines for exposure of the human body to high and low frequency electromagnetic fields. Follow the supplier's / manufacturer's instructions.

NEVER use your device without an antenna attached. Transmitting without an antenna may damage your device

NEVER touch the antenna when your device is transmitting. This may cause a minor burn to the skin and may affect the operational range of the antenna.

NEVER use your device if the antenna shows signs of damage.

#### 4.4 ELECTROMAGNETIC COMPATIBILITY REGULATORY INFORMATION (FCC AND ISED)

These devices generate, use and radiate RF energy and, if not installed and used in accordance with the instruction manual, may cause harmful interference to radio communications.

##### **FCC interference statement and compliance labelling**

This device complies with Part 15 of the FCC Rules. Operation is subject to the following two conditions: (1) this device may not cause interference, and (2) this device must accept any interference, including interference that may cause undesired operation of the device.

A label with the text above can be found in a conspicuous location of the MBS Unit for North America market.

##### **FCC Class B digital device notice**

This equipment has been tested and found to comply with the limits for a Class B digital device, pursuant to part 15 of the FCC Rules. These limits are designed to provide reasonable protection against harmful interference in a residential installation. This equipment generates, uses and can radiate radio frequency energy and, if not installed and used in accordance with the instructions, may cause harmful interference to radio communications. However, there is no guarantee that interference will not occur in a particular installation. If this equipment does cause harmful interference to radio or television reception, which can be determined by turning the equipment off and on, the user is encouraged to try to correct the interference by one or more of the following measures:

- Reorient or relocate the receiving antenna.
- Increase the separation between the equipment and receiver.
- Connect the equipment into an outlet on a circuit different from that to which the receiver is connected.
- Consult the dealer or an experienced radio/TV technician for help.

##### **ISED Canada ICES-003 compliance labelling**

This Class B digital apparatus has been fully tested and found to comply with the Canadian ISSED (Innovation, Science and Economic Development) standard ICES-003. A label with the text below can be found in a prominent location of the radio for North America market:

**CAN ICES-3 (B) / NMB-3 (B)**

#### 4.5 UL / SAFETY CERTIFICATIONS

The MBS Unit is UL certified, and complies with the requirements for electronic devices to minimise risks such as fire, electric shocks or injuries to the operator that may be caused in operation. File number is the following: E318948.



MBS Unit complies with the standard UL 60950-1 and UL 60950-22, including the National Differences for United States, Canada and CENELEC (Europe), and it has CB Test Certificate.

#### 4.6 EMC, SAFETY AND RF EXPOSURE STANDARDS

The equipment has been designed according to the following standards:

ETSI EN 300 394-1	Terrestrial Trunked Radio (TETRA); Conformance testing specification; Part 1: Radio
ETSI EN 301 489-1	Electromagnetic Compatibility and Radio spectrum Matters (ERM); ElectroMagnetic Compatibility (EMC) standard for radio equipment and services; Part 1: Common technical requirements
ETSI EN 301 489-5	ElectroMagnetic Compatibility (EMC) standard for radio equipment and services; Part 5: Specific conditions for Private land Mobile Radio (PMR) and ancillary equipment (speech and non-speech) and Terrestrial Trunked Radio (TETRA)
EN 50121-4	Railway applications - Electromagnetic compatibility - Part 4: Emission and immunity of the signaling and telecommunications apparatus
EN 60950-1 / IEC 60950-1 / UL 60950-1 / CSA 60950-1	Information technology equipment - Safety -- Part 1: General requirements
EN 60950-22 / IEC 60950-22 / UL 60950-22 / CSA 60950-22	Information technology equipment - Safety -- Part 22: Equipment to be installed outdoors
EN 50383	Basic standard for the calculation and measurement of electromagnetic field strength and SAR related to human exposure from radio base stations and fixed terminal stations for wireless telecommunication systems (110 MHz - 40 GHz)
EN 50385	Product standard to demonstrate the compliance of radio base stations and fixed terminal stations for wireless telecommunication systems with the basic restrictions or the reference levels related to human exposure to radio frequency electromagnetic fields (110 MHz - 40 GHz) - General public

Most of these standards ensure the essential requirements set out in Article 3 of Directive 2014/53/UE.

#### 4.7 MECHANICAL AND ENVIRONMENTAL STANDARDS

The equipment complies with the following standards:

##### 4.7.1 STANDARDS CENELEC

EN 60068-2-1 * No Functional. - 104 °F. Duration: 72 h * Functional: - 86 °F. Duration: 16 h.	Environmental testing -- Part 2-1: Tests - Test A: Cold
EN 60068-2-2 * No Functional. + 185 °F. Duration: 72 h * Functional: + 140 °F. Duration: 16 h.	Environmental testing -- Part 2-2: Tests - Test B: Dry heat
EN 60068-2-78 * Functional + 140 °F 93%. Duration 21 days.	Environmental testing -- Part 2-78: Tests - Test Cab: Damp heat, steady state
EN 60068-2-30 * Functional: 6 cycles 24 hours: • 12 hours. Temperature: + 140 °F. Relative humidity: 95% ± 5% • 12 hour: Temperature + 77 °F. Relative humidity: 98% ± 5%	Environmental testing -- Part 2-30: Tests - Test Db: Damp heat, cyclic (12 h + 12 h cycle)
EN 60068-2-11 No functional: 672 hours. + 95 °F +/- 35.6 °F. 5% ClNa	Environmental testing -- Part 2: Tests - Test Ka: Salt mist
EN 60529 * No functional. IP66	Degrees of protection provided by enclosures (IP Code).
EN 60068-2-9 * No functional. • Proc. B: 20 hours of solar radiation and 4 hours of darkness • Temperature: +104 °F • Humidity: 65% • Duration: 10 days	Environmental testing -- Part 2: Tests - Guidance for solar radiation testing.
EN 60068-2-64 * No functional: • Duration: 30 minutes by axe • 5-20 Hz. ASD: 0.01 g <sup>2</sup> /Hz. • 20-200 Hz. ASD; - 3dB/oct	Environmental testing -- Part 2-64: Tests - Test Fh: Vibration, broadband random and guidance.
EN 60068-2-6 * No functional: • Duration: 5 sweep by axe • 5-9 Hz. Displacement 0.05 in. • 9-200 Hz. Acceleration 0.41 g	Environmental testing -- Part 2-6: Tests - Test Fc: Vibration (sinusoidal).

<p>UNE-EN 60598</p> <ul style="list-style-type: none"> <li>* Vibration type: Sine swept</li> <li>* Frequency range: From 10 to 55 Hz</li> <li>* Amplitude (peak): <ul style="list-style-type: none"> <li>• 10 Hz Amplitude (peak): 0.06 in</li> <li>• 38 Hz Amplitude (peak): 2.04 g</li> <li>• 55 Hz Amplitude (peak): 2.04 g</li> </ul> </li> <li>* Number of axes: 3 axes</li> <li>* Swept ratio: 1 Oct./min.</li> <li>* Duration: 30 min./axis</li> </ul>	<p>Vibration: simulation of the fixing between MBS unit and mast.</p>
<p>Eurocode UNE-EN 1991-1-4</p> <ul style="list-style-type: none"> <li>* Wind speed: 124.27 mi /h (60.75 yd /s) (Safety factor 1.5)</li> <li>* Height in post: 21.87 yd</li> </ul>	<p>Protection for avoiding damages either in the enclosure and the fixing parts, due to meteo effects such as strong gusts of wind.</p>

#### 4.7.2 STANDARDS MIL-STD 810G

<p>MIL-STD-810G METHOD 502.5 procedure I, (C2): - 104 °F. Duration: 72 h</p>	<p>Cold (Storage and transportation).</p>
<p>MIL-STD-810G METHOD 502.5 procedure I, (C1): - 86 °F. Duration: 16 h</p>	<p>Cold (Operation).</p>
<p>MIL-STD-810G METHOD 501.5 procedure I (A1): + 185 °F. Duration: 72 h</p>	<p>Dry Heat (Storage and transportation).</p>
<p>MIL-STD-810G METHOD 501.5 procedure I (A2): + 140 °F. Duration: 16 h</p>	<p>Dry Heat (Operation).</p>
<p>MIL-STD-810G - Method 507.5, procedure II (Aggravated): (10 cycles, 24 hours) 86 °F - 140 °F at 95%rH.</p>	<p>Humidity.</p>
<p>MIL-STD-810G - Method 509.5 672 hours. + 95 °F +/- 35.6 °F. 5% ClNa.</p>	<p>Salt Fog.</p>
<p>MIL-STD-810G - Method 505.5: - Proc. B: 20 hours of solar radiation and 4 hours of darkness - Temperature: +104 °F - Humidity: 65% - Duration: 10 days</p>	<p>Solar Radiation (Sunshine).</p>
<p>MIL-STD-810G 514.6, Test procedure I, Category 4, table C-VI C3 (Figure 514,6 C-3)</p>	<p>Vibration.</p>
<p>MIL-STD-810G 516.6 Test procedure I and III, 0.71 oz 11 ms, half sinus</p>	<p>Shock.</p>

## 5. EQUIPMENT DESCRIPTION

### 5.1 VIEW

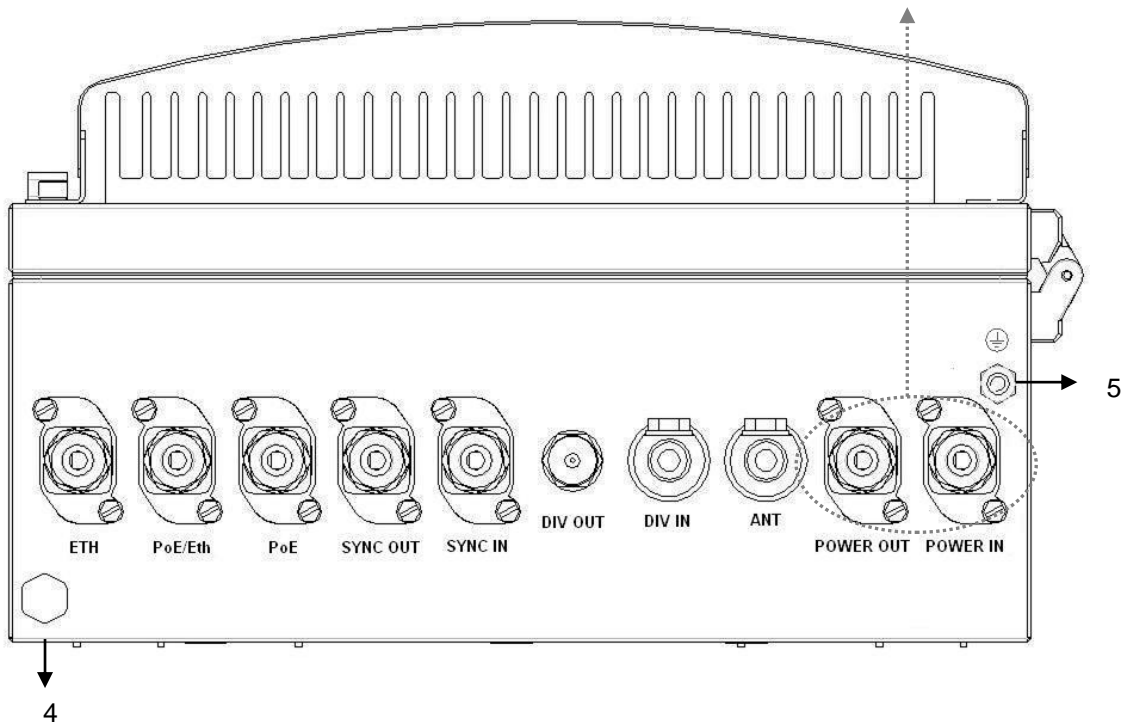
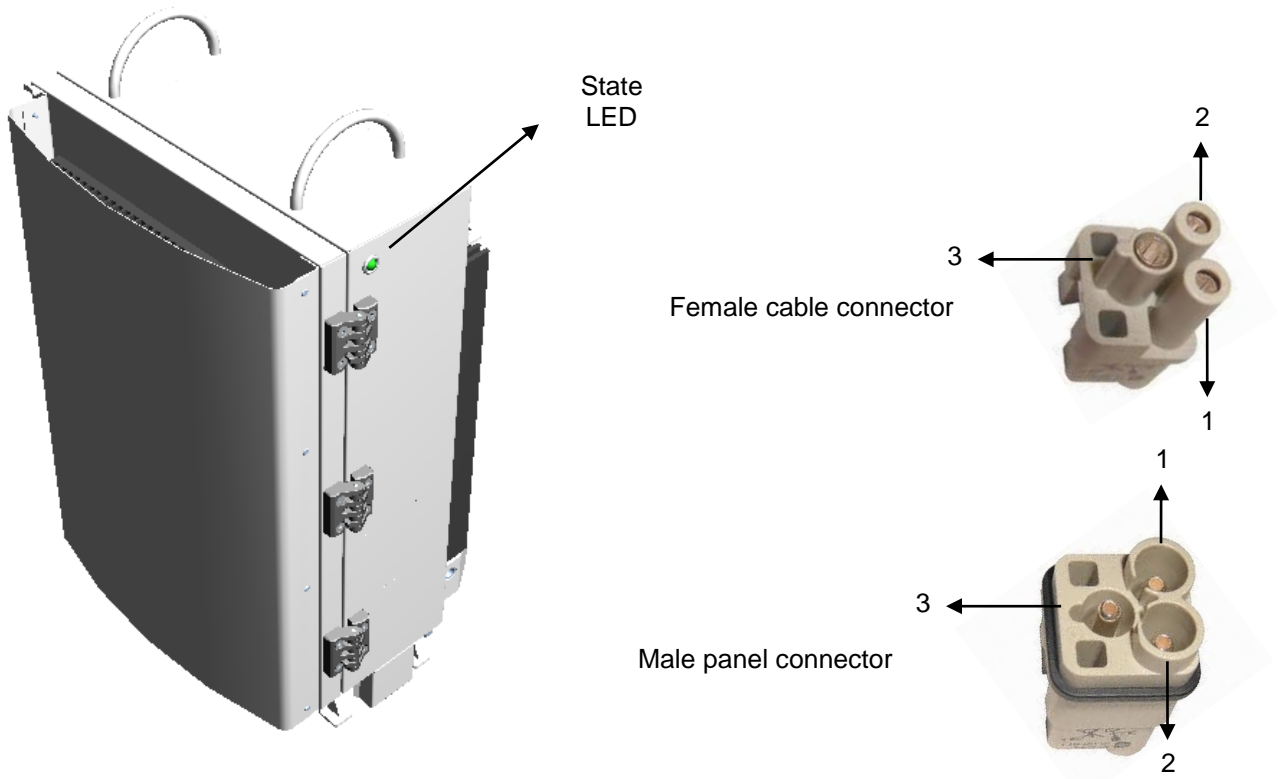

## 5.2 CONNECTORS

- 1.- Terminal with the following meaning depending on the MBS Unit Power option:
  - AC MBS Units: Neutral contact (N).
  - DC MBS Units: Negative contact (-).
- 2.- Terminal with the following meaning depending on the MBS Unit Power option:
  - AC MBS Units: Line contact (L).
  - DC MBS Units: Positive contact (+).
- 3.- Power supply Earth contact.
- 4.- Pressure equalizer.
- 5.- Chassis Earth contact.
- **ETH:** Connector that allows Ethernet connection between MBS Units. It also can be used as Maintenance Ethernet connector.
- **PoE/ETH:** Power Over Ethernet (IEEE 802.3af) connector. It provides power supply (48 VDC) and Ethernet connection to a PoE radio link. It can be used as Maintenance Ethernet connector if there is not radio link (Poe) connected. If the MBS Unit has the SNI IP option this connector is Layer 3.
- **PoE:** Power Over Ethernet (IEEE 802.3af) connector. It provides power supply (48 VDC) and Ethernet connection to a PoE radio link. If the MBS Unit has the SNI IP option this connector is Layer 3.
- **SYNC OUT:** Synchronism output connector. It provides synchronism to a second MBS Unit through its SYNC\_IN connector.
- **SYNC IN:** Synchronism input connector.
- **DIV OUT:** Output reception connector. It provides the receiver chain 2 to the next MBS Unit through its DIV IN connector.
- **DIV IN:** Reception antenna connector (receiver chain 2). It is connected to an antenna or to a MBS Unit DIV OUT connector (diversity 2).
- **ANT:** Transmission/reception antenna power connector (receiver chain 1).
- **POWER OUT:** Output power supply connector. It provides power supply to another MBS Unit with the same Power Supply option.
- **POWER IN:** Input power supply connector (VAC or VDC).

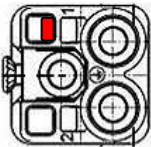
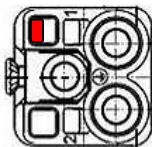

**Note:** **POWER\_IN** and **POWER\_OUT** connectors have a coding key to avoid wrong connections; on the following table is showed the location of this coding key depending on the MBS Unit power supply option.

External view of power supply panel connector	
AC Power Supply	DC Power Supply
	

**Note:** The amount of power delivered by both PoE and PoE/ETH connectors to the radio links can not exceed 35 W in total.

### 5.3 VISUAL INDICATORS

A MBS Unit has a LED indicator that, depending on its state, will indicate the function of the MBS Unit

The LEDs show the MBS Unit state:

LED	TYPE	NORMAL STATE	FUNCIÓN
STATE	Tricolor	Green ON / Orange ON	<ul style="list-style-type: none"> <li>• <b>Green On:</b> MBS Unit is operating and transmitting.</li> <li>• <b>Green flashing:</b> MBS Unit initializing</li> <li>• <b>Red On:</b> There is no link with CNC and no control from any LSC.</li> <li>• <b>Red flashing:</b> When MBS Unit is controlled by the CNC, showing any kind of alarm other than the communication one is NOT OK.</li> <li>• <b>Orange On:</b> MBS Unit is operating and transmitting in fallback mode.</li> <li>• <b>Orange flashing:</b> When MBS Unit is in fallback mode, showing any kind of alarm other than the communication one is NOT OK.</li> <li>• <b>OFF:</b> The equipment is either without power source or is damaged.</li> </ul>

**5.4 DIMENSIONS**

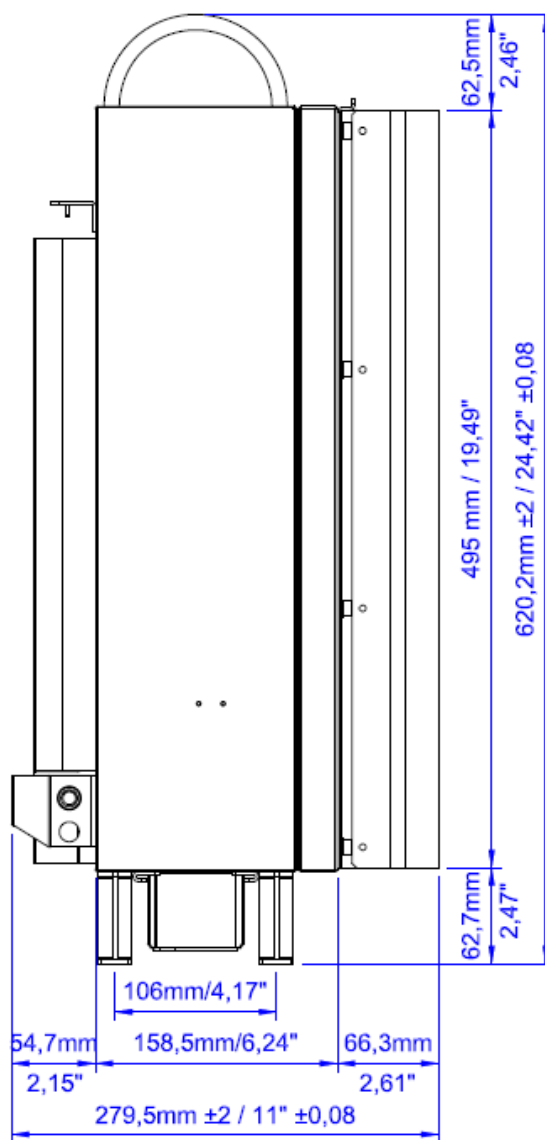
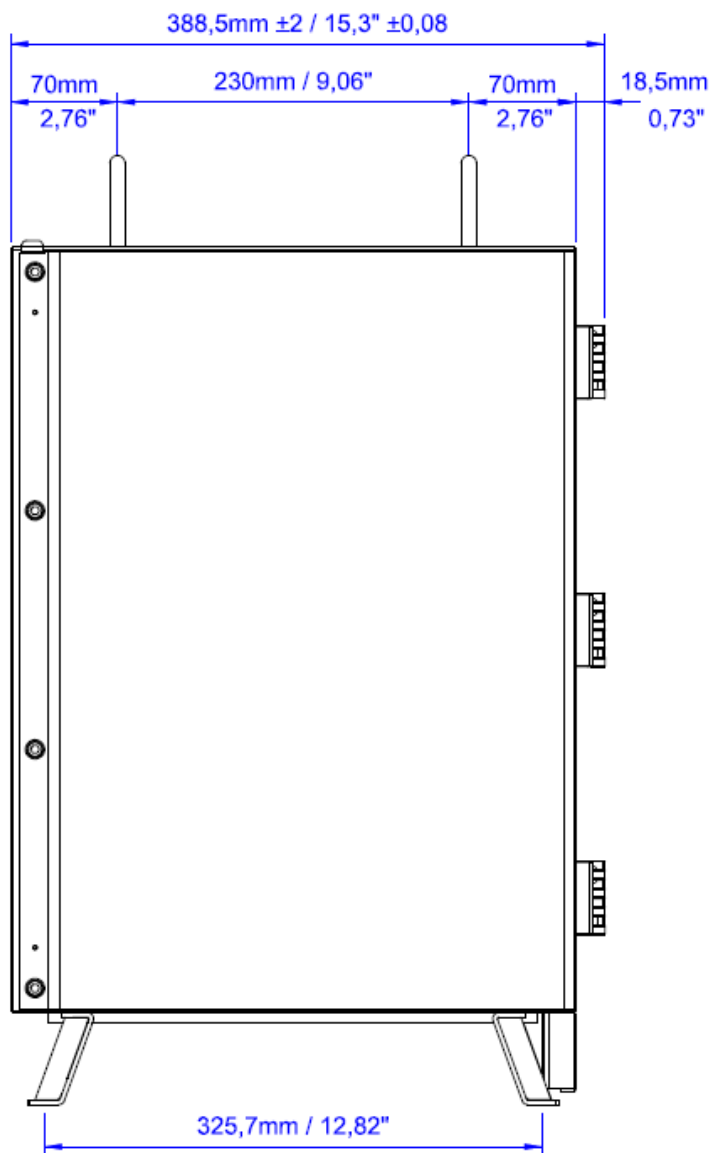

## 6. INSTALLATION GUIDE

The following recommendations must be followed before powering on the MBS Unit module.

Next diagram shows the steps to be followed to carry out the installation:

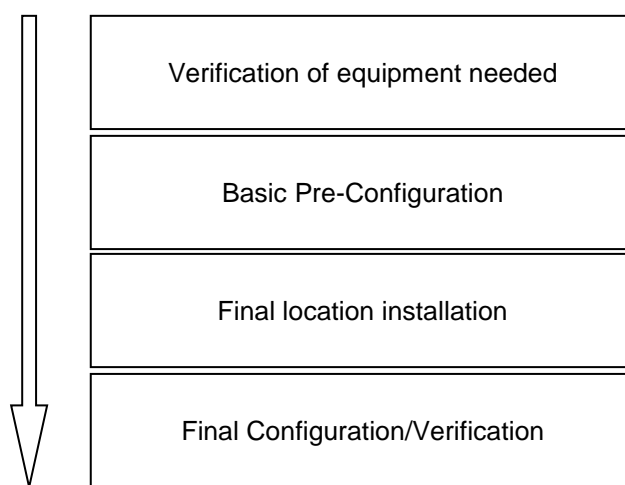

## 6.1 NECESSARY EQUIPMENT



Make sure you have the necessary equipment depending on the configuration to install. If any of the elements necessary to carry out the installation process described in this manual, were lost or damaged, contact your supplier and / or installer.

Necessary equipment		
Element	Code	Comments
MBS Unit	D148X01PT	<p>“x” varies depending on band.</p> <p>Each MBS Unit includes:</p> <ul style="list-style-type: none"> <li>- MBS Unit equipment</li> <li>- Power supply cable connector</li> <li>- Ethernet cable connector</li> <li>- RF superflexible wire N-Male ↔ N-Male</li> <li>- Brackets for installation</li> </ul>
Anti-vandal kit	D014000PT	It is only necessary if anti-vandal protection is required.
Ethernet cable connector	225120	Every MBS Unit includes one connector of this type; if a MBS Unit must be connected to two radio links, it is necessary to have a second unit.
RF superflexible wire N-Male ↔ N-Male	208931	Each MBS Unit includes one cable of this type; if a MBS Unit requires diversity 2 on reception it is necessary to have a second unit.
Additional carrier interconnection kit	D014001PT	It is mandatory in case of connecting a second MBS Unit to the first MBS Unit.
NMS Server-Client Rugged Laptop	D484904XPT	It is only necessary if the MBS Unit is required to operate in Isolated Mode.
Mounting Accessories		
PBS Accessory	D014002PT	Transport hand truck accessory for MBS Unit.

Additional equipment to be considered for installation	
Element	Comments
Cable to power the MBS Unit.	See features in external power connection section. One power supply cable connector is supplied with the MBS Unit.
Ethernet cable to connect PoE radio links	See features in Ethernet connection section. One Ethernet cable connector is supplied with the MBS Unit.
Antenna coaxial cable and antenna.	See features in Antenna connection section.

Tools	
Element	Comments
Toolbox	In addition to the usual material used for installations (wrenches, screwdrivers ...) it is necessary to use: <ul style="list-style-type: none"> <li>- Torque wrench for 0.67 in hexagonal nut capable of delivering 15 Nm.</li> <li>- Vulcanizable tape.</li> </ul>
Ethernet Cable	Cable to make specific maintenance tasks in the field

## 6.2 BASIC PRE-CONFIGURATION

Before connecting the MBS Unit to the infrastructure it should have the IP address correctly configured in order to have remote access once it is connected (to set the IP address, see the configuration chapter (F067220PT) in technical manual).

### Steps:

- Apply power supply to the MBS through its **POWER\_IN** connector.
- Wait 3 minutes until the MBS Unit initializes.
- Connect the PC, to set the IP address, to the **ETH** connector.
- Change the IP address according to the network IP addressing plan.
- Check that IP address was successfully changed through a “ping” from the PC to the new IP address of the MBS Unit.

### **6.3 INSTALLATION**

The MBS has been designed to be mounted on both mast/pole, on a wall or over a PBS Accessory. This chapter provides the necessary steps to be followed for a right MBS Unit installation.

At least two people are required to carry out the installation of a MBS Unit on a mast/pole.

Note: MBS Unit has been designed to operate in vertical position. In case of being necessary the operation in horizontal position, the client will must check with the manufacturer. In this case, the range of temperature will be reduced (-86 °F to 122 °F).

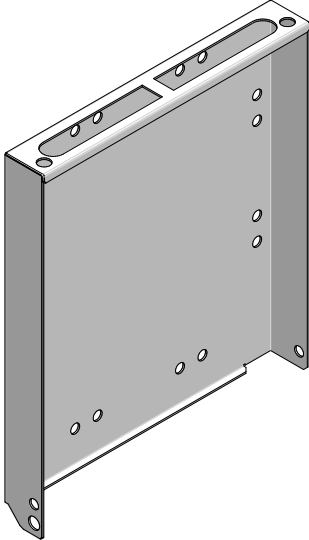
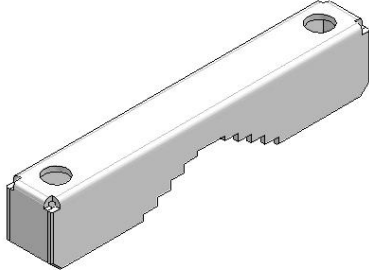
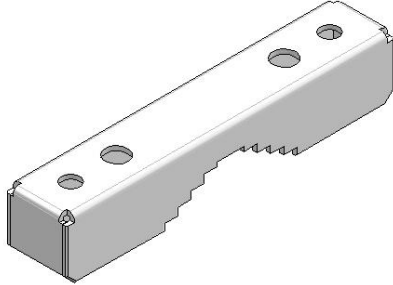

**Bracket system:**

1 x Bracket	2 x clamp (2 holes)	2 x clamp (4 holes)
		

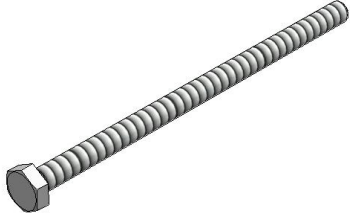
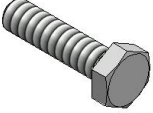
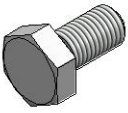
4 x Bolt M10x180 (Clamp attachment)	6 x Bolt M10x40 (lateral attachment MBS-Bracket & Clamp-Bracket)	2 x Bolt M10x20 (Top attachment MBS-Bracket)
		

12 x Grover washer DIN 127 Ø10	12 Plain washer DIN125 x Ø10	
		<p>---</p>

## 6.3.1 MAST/POLE INSTALLATION

### 6.3.1.1 MAST/POLE SELECTION

The types of section of the mast/pole where the MBS Unit can be mounted are the followings:

- ❑ Circular section: Diameter from 1.18 in to 5.12 in.
- ❑ Square section: From 1.18 in x 1.18 in to 3.35 in x 3.35 in.
- ❑ L section: From 1.18 in x 1.18 in to 4.33 in x 4.33 in.

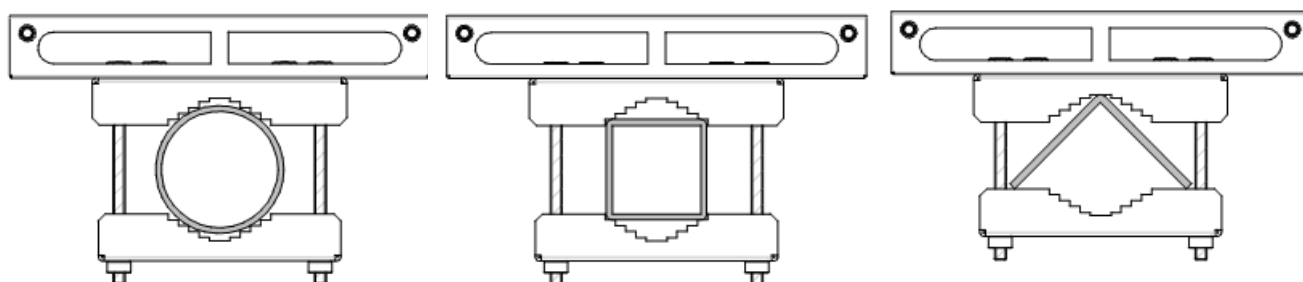

In the choice of the mast/pole where the MBS Unit is being installed the following recommendations must be followed:

- ❑ The mast/pole has to support the loads due to the installation of some elements on them.
- ❑ The mast/pole has to support the loads due to the action of the wind, snow as well as its own weight, because these are going to induce its flexion.
- The mast/pole must have the enough inertia both lateral and frontal in order that the actions of different loads do not induce permanent deformations on it.
- ❑ The manufacturer of the mast/pole must evaluate the structural factor of the mast/pole correctly depending on its type.
- ❑ It is necessary to take into account both the height where the MBS Unit is installed and its weight/dimensions (See section “MBS Unit” in chapter (F067326PT) “SBS Technical Description” in the Standard Technical Manual).



It is recommended to choose a lattice mast/pole in case of this one has a high height and it is going to be submitted to important flexion efforts. In any case, it is responsibility of the manufacturer of the mast/pole to determine if the resistant section of mast/pole is suitable.

The brackets should be installed tight enough to support the MBS Unit without causing deformation of the mast/pole or areas of corrosion.

Once mounted in its definitive location, if the vandal resistant kit is available, it will prevent the access / disassembly not authorized.

In case of installing more than one MBS Unit on the same mast/pole, it is recommended not to mount one above the other one to avoid the heat transfer from the MBS Unit low to the MBS Unit high. If the MBS Units have to be installed in the same vertical axis these must be oriented in different directions to increase the separation of them as far as possible, depending on the length of wiring between both equipments (1.64 yd approximately).

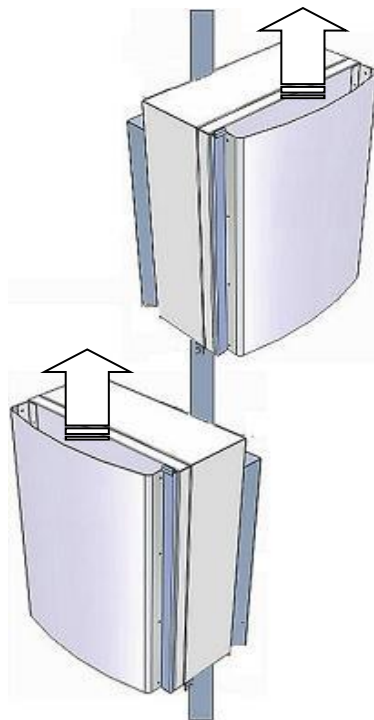

### 6.3.1.2 MAST/POLE MOUNTING INSTRUCTIONS

Steps to install a MBS on a mast/pole:

1. Place the MBS Unit bracket on the mast/pole as follows.

**Note:** Handle the MBS Unit bracket with care if it rests on the floor. Place some protection underneath to prevent scratches on the surface.

- a) Secure 4 holes clamps on the bracket by tightening the bolts with a 20 Nm torque, using a 0.67 in torque wrench, do not forget to place the washers

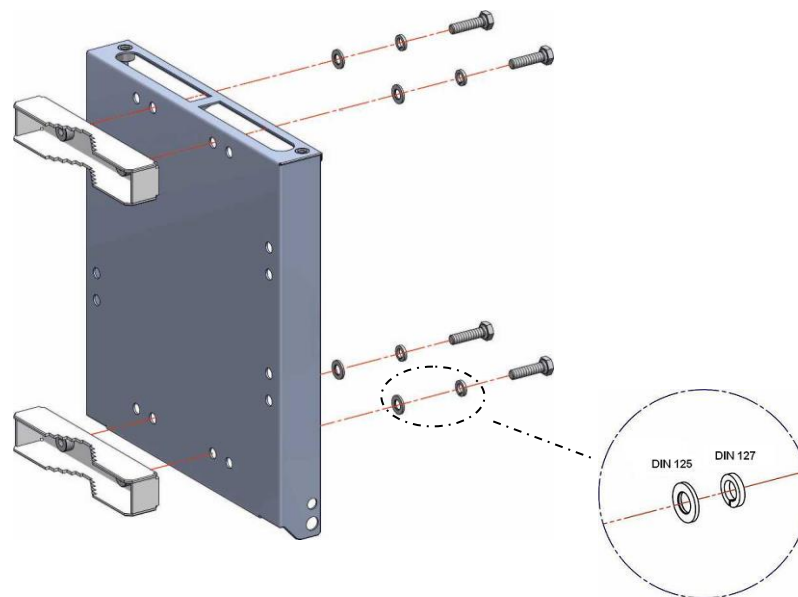

- b) Install the bracket to the desired final location on the mast/pole. Embrace the 2 holes clamps and screw these to the bracket with a 0.67 in wrench and 20 Nm torque. Due to the length of the bolts it is advisable to screw them slowly.

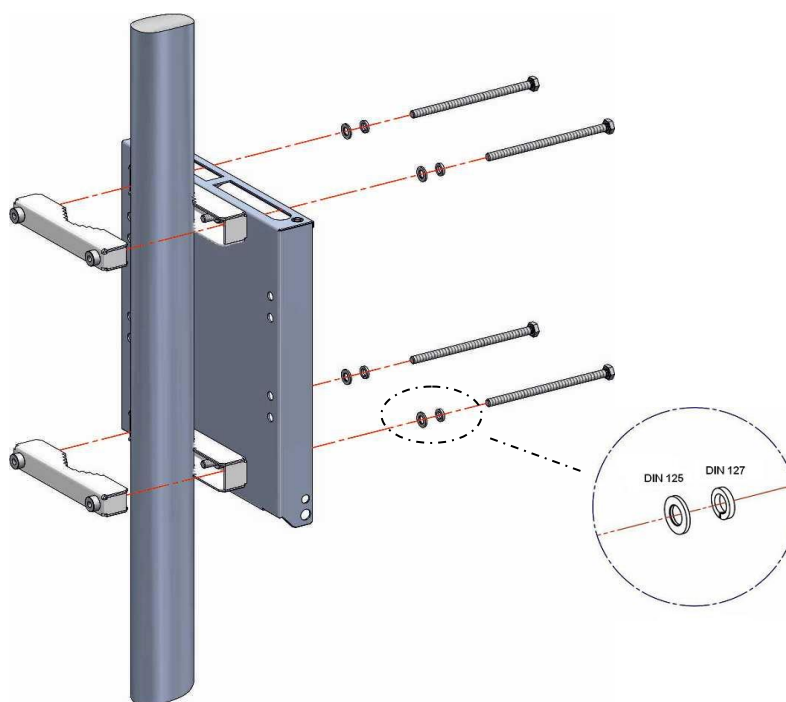

2. Place MBS Unit on the bracket as follows.

- a) Raise the MBS Unit to the position where the bracket is placed on the mast/pole and hang it on the bracket, tilting slightly to match the bracket guides as indicated in the following figure:

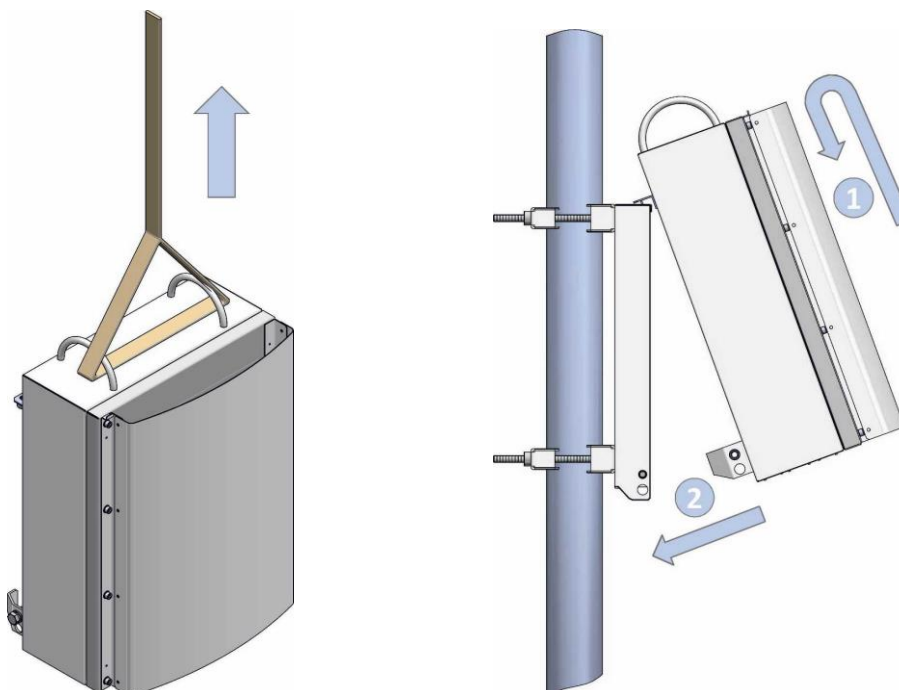

To prevent accidents during the MBS installation, for safety it is highly recommended to use a second rope.

- b) Put the bolts of the MBS Unit and washers to the bracket with a 0.67 in wrench and 25 Nm torque.

**Note:** If anti-vandal kit is available (D014000PT), lateral bolts should be placed after mounting the anti-vandal kit.

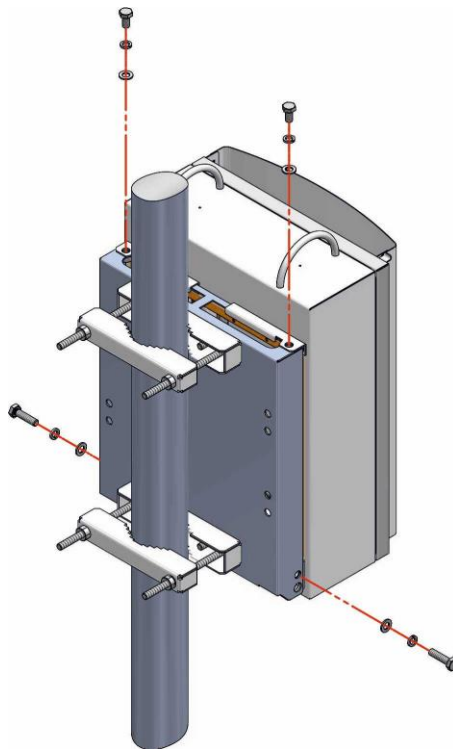

3. Make the necessary wiring connections as described in the connections section in this guide.

### 6.3.2 WALL INSTALLATION

To install the MBS Unit on a wall, make the following steps:

1. Mark the position of the holes using the bracket as a template itself with the help of a level  
**Note:** To ensure proper ventilation there must be at least 27.56 in clearance above and below each MBS Unit. There must also be a minimum distance of 11.81 in free on both sides of the MBS Unit.

**Note:** The screws, expansion bolts and washers needed to secure the brackets to wall are not supplied with the unit.

The distance between the holes are shown in the following figure.

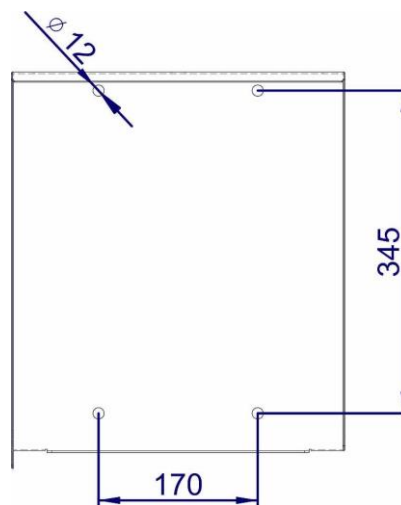

2. Drill holes on the wall and insert a rawplug in each hole.

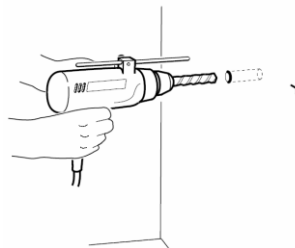

3. Place the bracket over the rawlplug and insert the bolts and washers. Finally screw them with a 0.67 in wrench and 20 Nm torque.

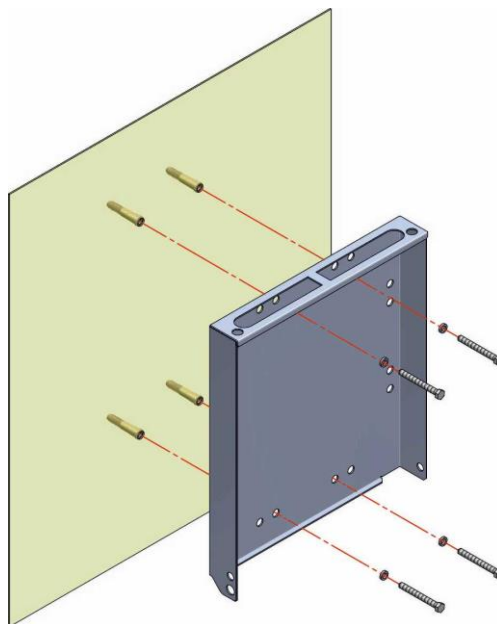

4. Place the MBS Unit on the bracket as follows.
  - a) Raise the MBS Unit to the position where the bracket is placed and hang it on the bracket, tilting slightly to match the anchor guides as indicated in the following figure:

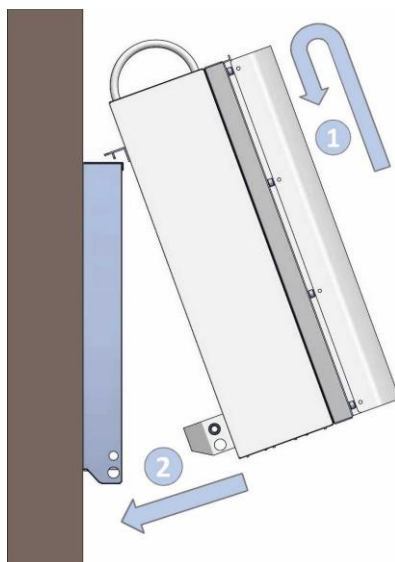



- b) Put the bolts of the MBS Unit and washers to the bracket with a 0.67 in wrench and 25 Nm torque. The order is bolt + grower washer + plain washer.

**Note:** If anti-vandal kit is available (D014000PT), lateral bolts should be placed after mounting the anti-vandal kit.

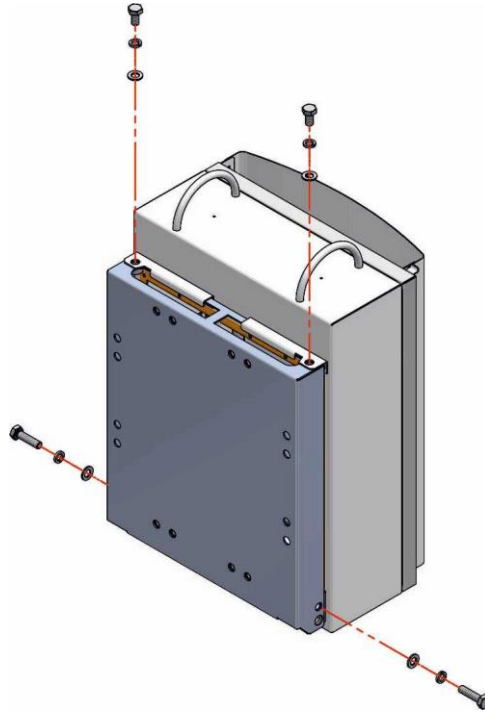





5. Make the necessary wiring connections as described in the connections section in this guide.

### 6.3.3 PBS ACCESSORY INSTALLATION

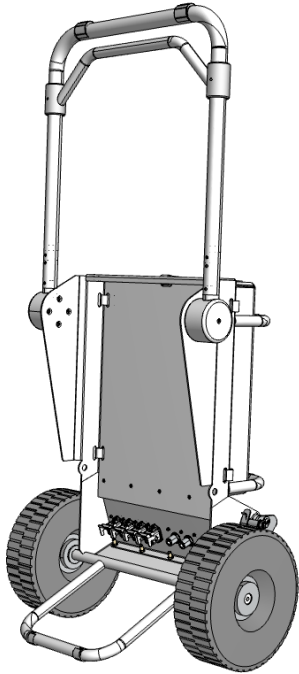
The PBS Accessory (D014009) is a hand truck element that allows one person to transport a MBS Unit.

**PBS Accessory:**

1 x PBS Hand Truck	1 x Power Cable
	
	4 x Ethernet Cable
	
	3 x RF Cable
	

The following steps must be done to install a MBS Unit over a PBS Accessory:

1. Put the MBS Unit in horizontal position, place it over the back radiator and remove all the connectors covers except the covers of the PWR OUT and ETH connectors as shown in the following picture:

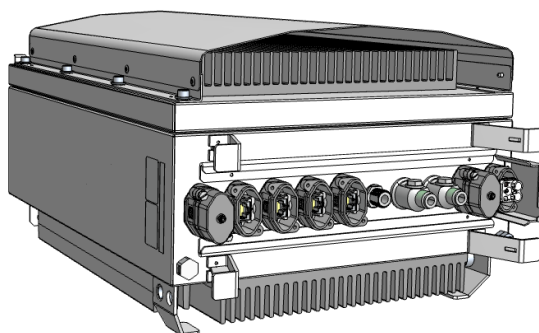

2. Connect the cables on its corresponding ports of the MBS Unit according to the following order:

- 4 x Ethernet Cables: PoE/ETH, PoE, SYNC OUT and SYNC IN
- 3 x RF Cables: ANT, DIV OUT and DIV IN
- 1 x Power Cable: POWER IN

**Note:** The POWER OUT and ETH connectors must be closed with covers.

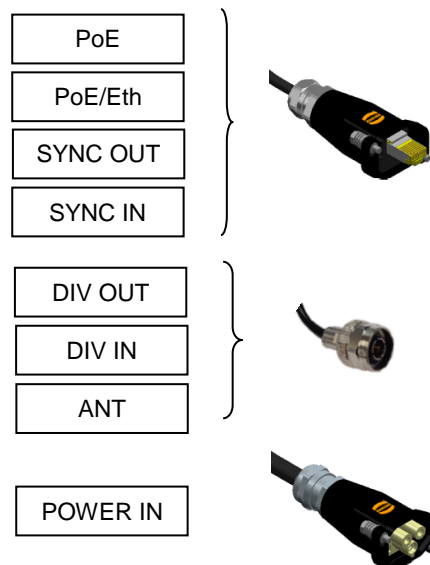
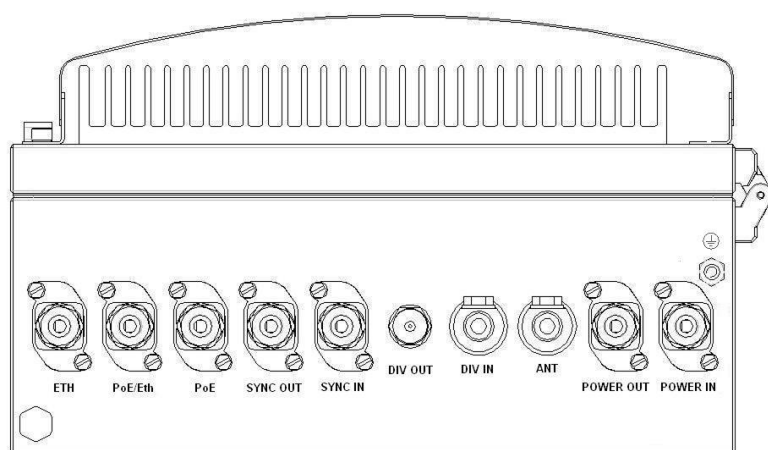

3. After connecting all the cables into the MBS Unit, the hand truck must be placed in Operating position to mount the carrier. In this position, the hand truck leans down backwards with the bracket exposed to the front and the moving arm working as a supporting point.

**Note:** The brake system of the hand truck must be activated to avoid any movement during the installation of the MBS Unit.

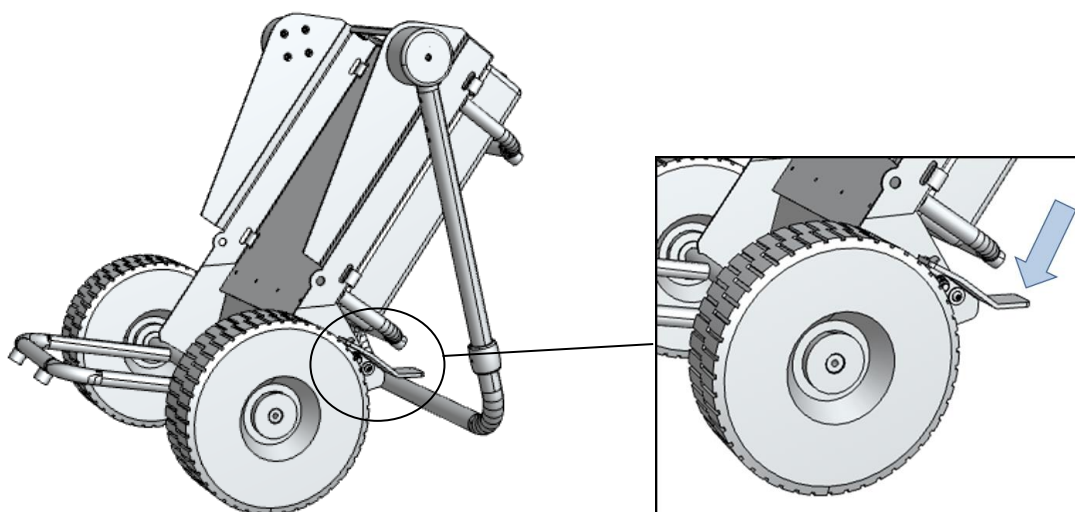

4. Put the MBS Unit over the hand truck bracket as indicated below:

- a) Lift up the MBS Unit until getting the bracket position and lean it softly to reach the anchor guides as shown in the following figure:

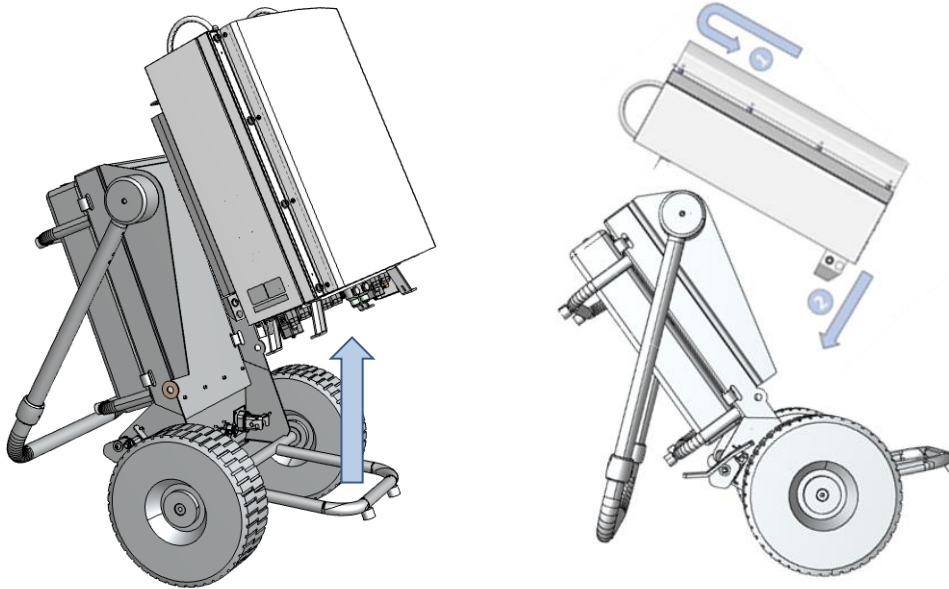

- b) Place the clamping washers and screws in the hand truck bracket with a torque wrench of 0.67 in and torque 25 Nm. The order is the following:

- 1) Flat washer
- 2) Grover washer
- 3) Screw

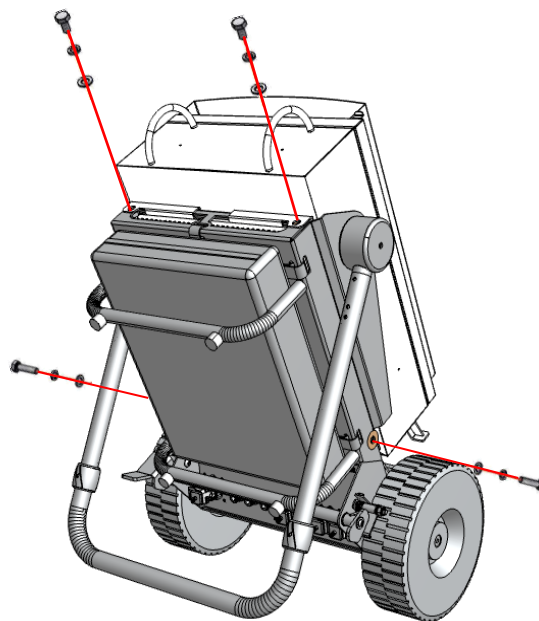

5. Connect one by one the cables previously fixed in the MBS Unit in the corresponding connectors of the hand truck connector panel. Except the PWR OUT and ETH that will be covered, the rest of cables must have a corresponding connector in the interconnection panel.
6. Verify that all the connections are secured with the panel connector locking system closed and that correctly holds the aerial connector coming from the MBS Unit.

### 6.3.3.1 WORKING POSITIONS

The PBS Accessory permits 3 working positions: Manual Transport, Vehicle Transport and Operating Position.

To get any of the positions previously mentioned, the following elements of the PBS accessory must be taken into account:

#### Wheel blocking system

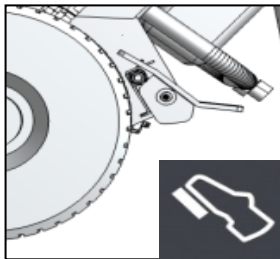

#### Adjustable Handle

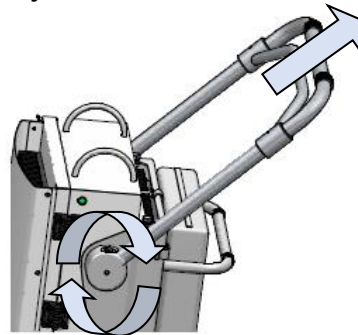

**Note:** The wheels must be blocked in any other position different than Manual Transport.

#### 6.3.3.1.1 MANUAL TRANSPORT POSITION

To manually transport the MBS Unit with the PBS Accessory the wheels must be unblocked and the adjustable handle has to be placed just as indicated below:

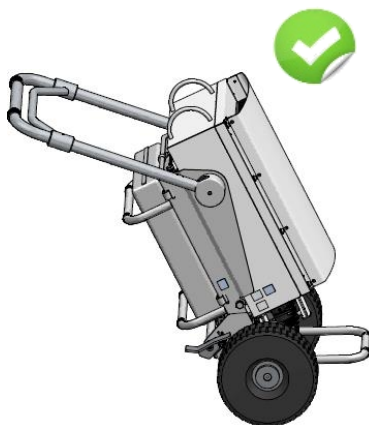

### 6.3.3.1.2 VEHICLE TRANSPORT POSITION

To perform an vehicle transport of the MBS Unit with the PBS Accessory, the adjustable handle must be placed to the front and the whole set must be inclined to the back using the adjustable handle as support point as shown below:

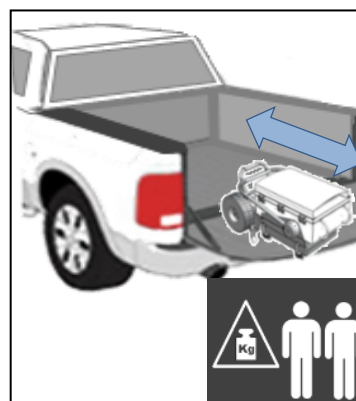
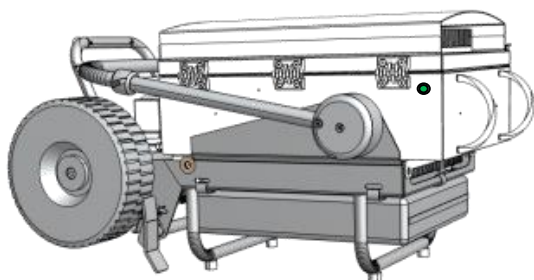

**Note:** the set composed by MBS Unit and the PBS Accessory has a heavy weight, the actions of loading and unloading into the vehicle must be done by at least two persons.

### 6.3.3.1.3 OPERATING POSITION



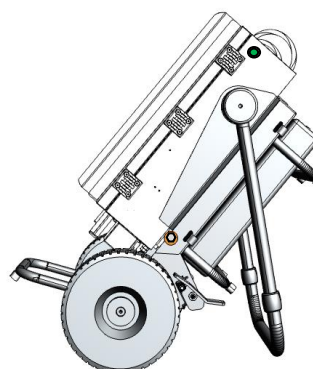
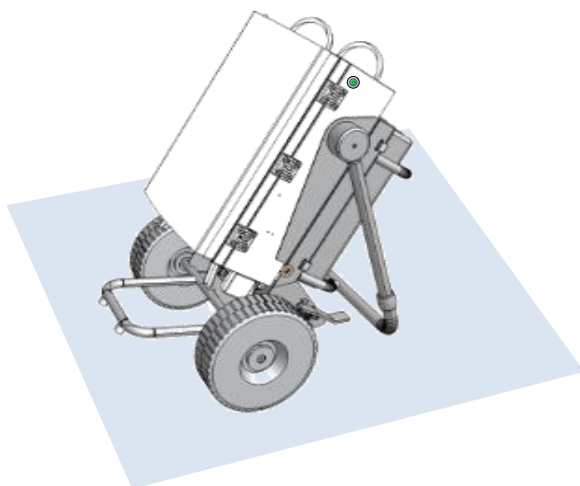

To correctly operate the set composed by the MBS Unit and PBS Accessory, the adjustable handle must be placed backwards to use it as supporting point as shown below:

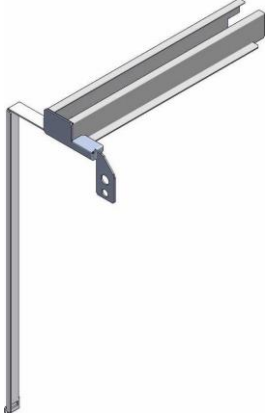

### 6.3.4 ANTI-VANDAL KIT INSTALLATION

The anti-vandal kit for MBS Unit is an optional accessory (D014000PT). Either the MBS Unit is mounted on a mast/pole or on a wall, the anti-vandal kit, is performed as follows. Take into account that the installation of the anti-vandal kit should be done once you have completed the wiring connections of the MBS Unit.

**Anti-vandal Kit:**

Anti-Vandal Kit	6 x Torx screw M3X4	6 x Grower washer	1 x padlock
			

- Place the anti-vandal kit and slide the kit guides as shown on the following figure:

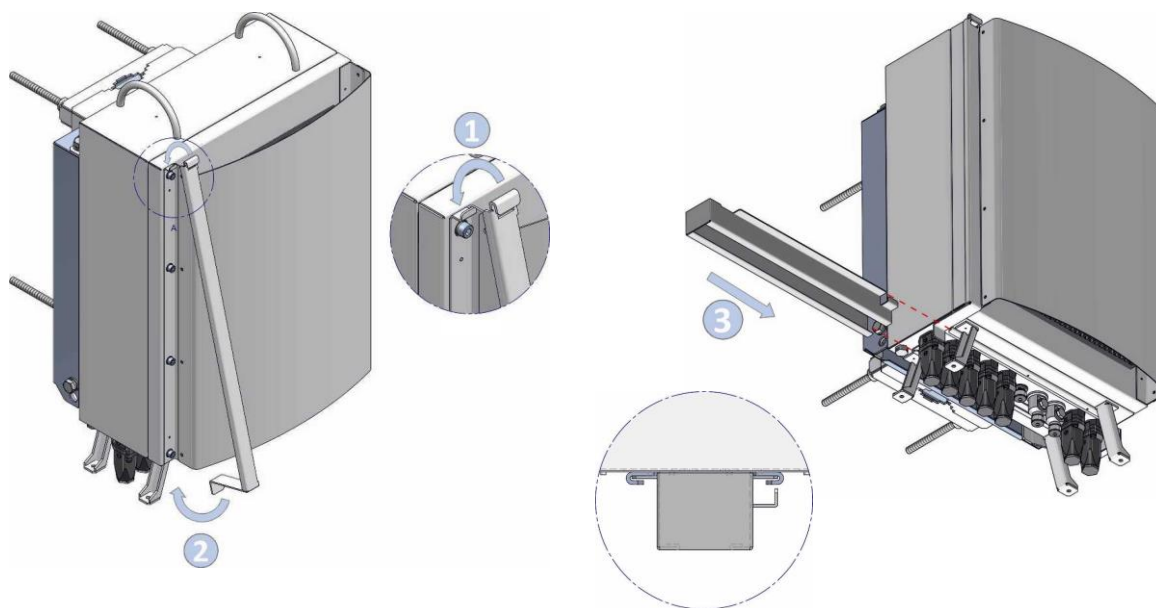



- Place the padlock and screw the attachment bolt to the bracket with a 0.67 in wrench and 25 Nm torque.

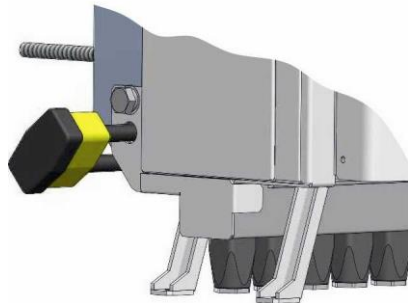

### 6.3.5 REQUIREMENTS TO CONSIDER DURING THE ANTENNA INSTALLATION

The antennas installation always will depend on TX frequencies assigned to each MBS Units that are part of a MBS.

As a general rule, the frequencies assigned to the MBS Units of each MBS shall comply with the following restrictions:

**Sub-band.**

When the MBS Units belong to the same band, these must belong to the same sub-band. Otherwise, the duplexer TX and RX filters do not provide the necessary insulation. For example, you should not combine a MBS Unit with 390-395 MHz TX subband with another with 395-400 MHz TX subband.

**Frequency spacing:**

$$\Delta f \neq DS/n$$

$$\Delta f \neq DS/n \pm 25 \text{ KHz}$$

If DS/n is not a multiple of 25 KHz, take the multiple of 25 KHz nearest lower value to DS/n and its 2 adjacent channels ( $\pm 25 \text{ KHz}$ ).

Where:

$\Delta f$  is the TX frequency spacing between the MBS Units.

**DS** is the duplex spacing,

**n** is an integer number.

If the MBS Units are combined into one antenna, will be mandatory fulfill the restrictions listed above.

If each MBS Unit has its own antenna, there are several possible cases depending on the level of compliance with the foregoing restrictions:



- **Case 1:** All MBS Units in the MBS comply with the restrictions about subband and frequency separation. In this case, is allowed to install all the antennas in the same horizontal plane following the guidelines normally applied for SBS sites about the horizontal distance between each antenna and the mast.



- **Case 2:** The restrictions about subband and frequency separation are not complied between the MBS Units in the same MBS. In this case, the antennas installation should be done keeping an enough vertical separation between each antenna of MBS in order to obtain the necessary isolation to avoid, when all MBS Units are transmitting, an increase in the RSSI level respect to the level measured when the MBS Units are not transmitting.

This option is not advisable, especially if the tower which antennas will be installed is not elevated over the ground, because may be differences of coverage between the upper antenna and the lowest that could affect the communications performance.



### 6.3.6 CONNECTIONS

This section shows the connections to be made and the characteristics of the material to be used. The MBS Unit is a weather-protected device once the equipment has been installed in its final location; make sure that there is no MBS Unit connector without plug or cable connected. Besides, the external wiring connections of the MBS Unit must be protected from weather, (vulcanizable tape can be used if it is necessary).

To connect two MBS Units you must have the interconnection kit for additional carrier (Cod. D014001PT). This is obtained as an independent accessory. In the following table is showed the connection between two MBS Unit using the interconnection kit

Connections	MBS_1 connector	MBS_2 connector
Power Supply	Power_OUT	Power_IN
Ethernet	ETH	ETH
Synchronism	SYNC_OUT	SYNC_IN
Diversity in reception	DIV_OUT	DIV_IN
	DIV_IN	DIV_OUT

For MBS units without duplexer (O148051), the following external filter must be installed:

Frequency range	Attenuation in RX relative to the pass band	Attenuation in TX relative to the pass band
380 – 470 MHz	80 dB @ TX band 60 dB @ offset <sup>(1)</sup> > 10 MHz	80 dB @ RX band 60 dB @ offset <sup>(1)</sup> > 10 MHz
763 – 806 MHz	91.5 dB @ TX band 70 dB @ offset <sup>(1)</sup> > 32 MHz	85 dB @ RX band 70 dB @ offset <sup>(1)</sup> > 32 MHz
806 – 870 MHz	80 dB @ TX band 60 dB @ offset <sup>(1)</sup> > 20 MHz	80 dB @ RX band 60 dB @ offset <sup>(1)</sup> > 20 MHz

<sup>(1)</sup> Frequency offset from the upper and lower edges of the band pass.

### 6.3.6.1 SUPPORTED CONFIGURATIONS

#### 6.3.6.1.1 ONE MBS UNIT WITH DIVERSITY 1 IN RECEPTION

The connections are the following ones:

- ❑ Power supply 220/110 VAC or 24 VDC.
- ❑ From **ANT** connector to the antenna.
- ❑ Connection with radio link through **PoE** or **PoE/ETH** connector (if the MBS Unit has SNI IP option these connectors are Layer 3).
- ❑ Maintenance through **ETH** connector (Layer 2).



### 6.3.6.1.1.1 CONFIGURATION WITH PBS ACCESSORY

The connections are the following ones:

- ❑ Power supply 220/110 VAC or 24 VDC.
- ❑ From **ANT** connector to the antenna.
- ❑ Connection with radio link through **PoE** or **PoE/ETH** connector (if the MBS Unit has SNI IP option these connectors are Layer 3).
- ❑ Connection with the NMS Server-Client Rugged Laptop through the PoE/ETH connector (Only in Isolated Operation Mode)

**Note:** The connection with the NMS Server-Client Rugged Laptop in the PoE/ETH connector depends of the network topology and just applies in Isolated Operation Mode of the MBS Unit.

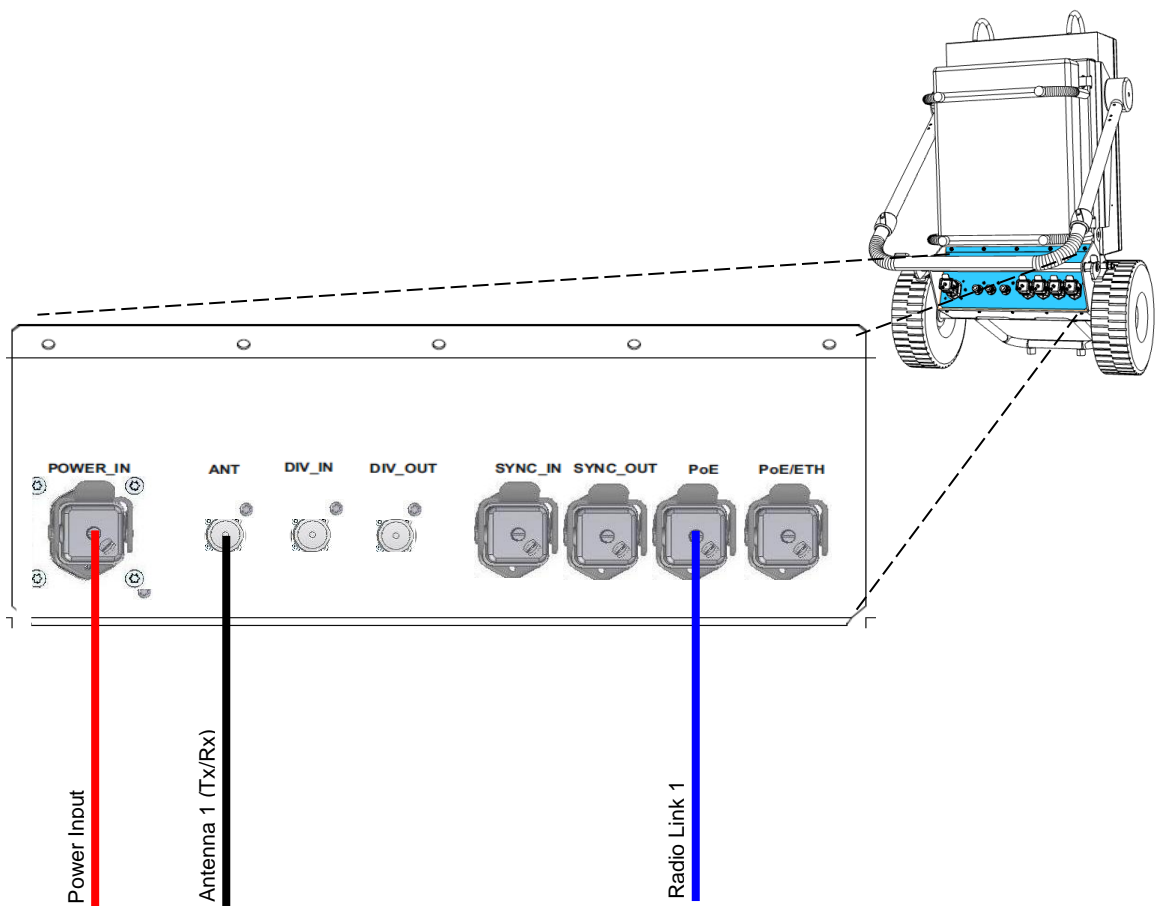

### 6.3.6.1.2 ONE MBS UNIT WITH DIVERSITY 2 IN RECEPTION

The connections are the following ones:

- ❑ Power supply: 220/110 VAC ó 24 VDC.
- ❑ From **ANT** connector to the first antenna.
- ❑ From **DIV IN** connector to the second antenna.
- ❑ Connection with radio link through **PoE** or **PoE/ETH** connector (if the MBS Unit has SNI IP option these connectors are Layer 3).
- ❑ Maintenance through **ETH** connector (Layer 2).

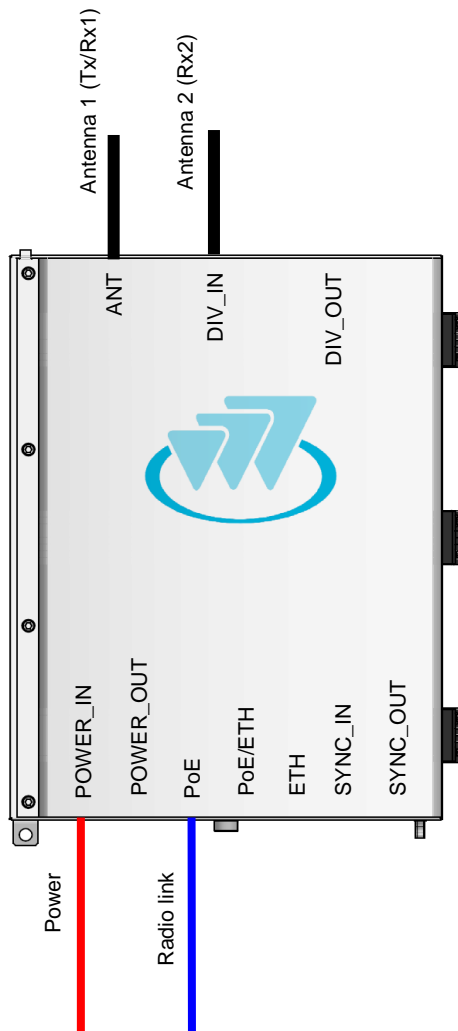

### 6.3.6.1.2.1 CONFIGURATION WITH PBS ACCESSORY

The connections are the following ones:

- ❑ Power supply: 220/110 VAC ó 24 VDC.
- ❑ From **ANT** connector to the first antenna.
- ❑ From **DIV IN** connector to the second antenna.
- ❑ Connection with radio link through **PoE** or **PoE/ETH** connector (if the MBS Unit has SNI IP option these connectors are Layer 3).
- ❑ Connection with the NMS Server-Client Rugged Laptop through the **PoE/ETH** connector (Only in Isolated Operation Mode)

**Note:** The connection with the NMS Server-Client Rugged Laptop in the PoE/ETH connector depends of the network topology and just applies in Isolated Operation Mode of the MBS Unit.

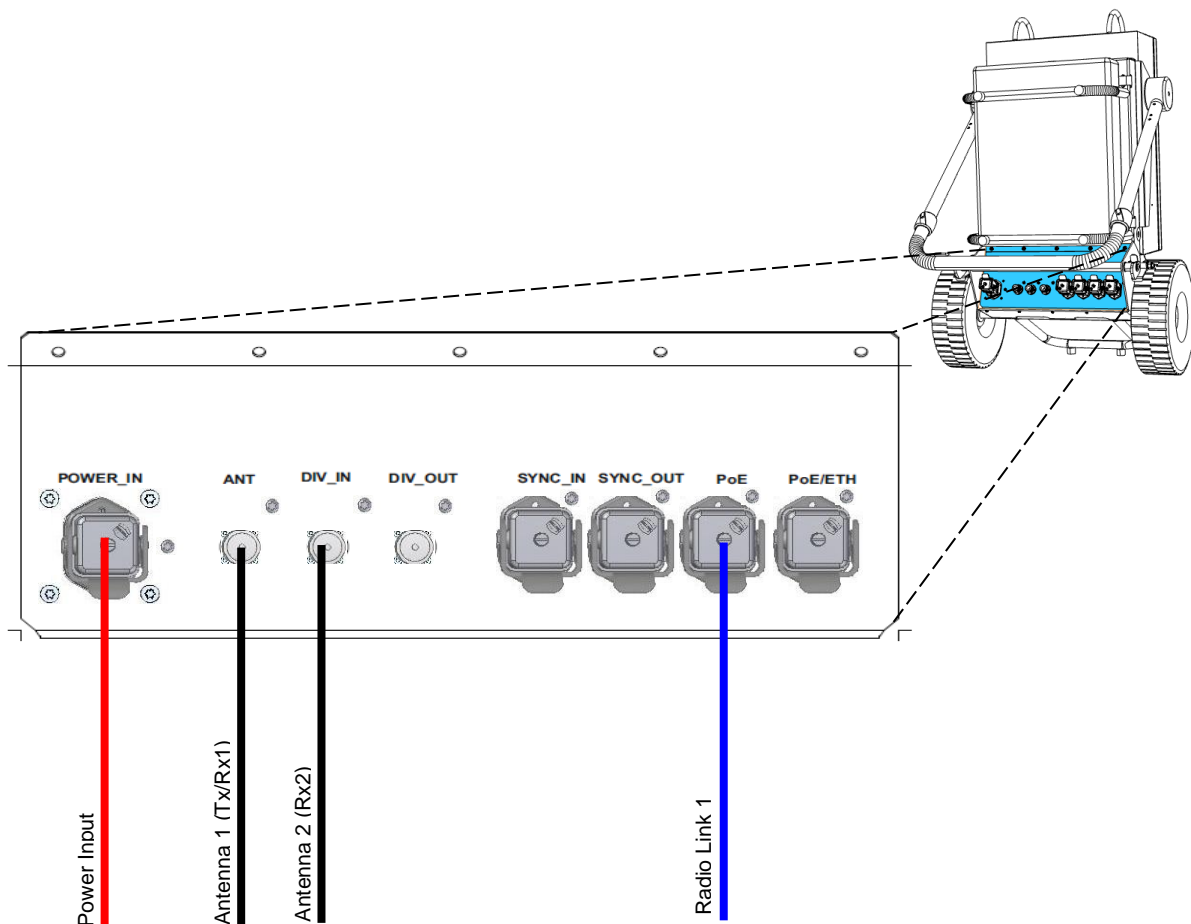

### 6.3.6.1.3 TWO MBS UNIT (SAME SUBBAND) WITH DIVERSITY 1 OR 2 IN RECEPTION

**NOTE:** Diversity 1 or 2 mode can be selected from the NMS client.

The connections are the following ones:

- ❑ Power supply for the MBS Unit 1: 220/110 VAC or 24 VDC.
- ❑ From **ANT** connector of the MBS Unit 1 to the first antenna.
- ❑ From **ANT** connector of the MBS Unit 2 to the second antenna.
- ❑ Connection with radio link through **PoE** connector (if the MBS Unit has SNI IP option this connectors is Layer 3).
- ❑ Maintenance through **PoE/ETH** connector (if the MBS Unit has SNI IP option this connector is Layer 3 otherwise is Layer 2).

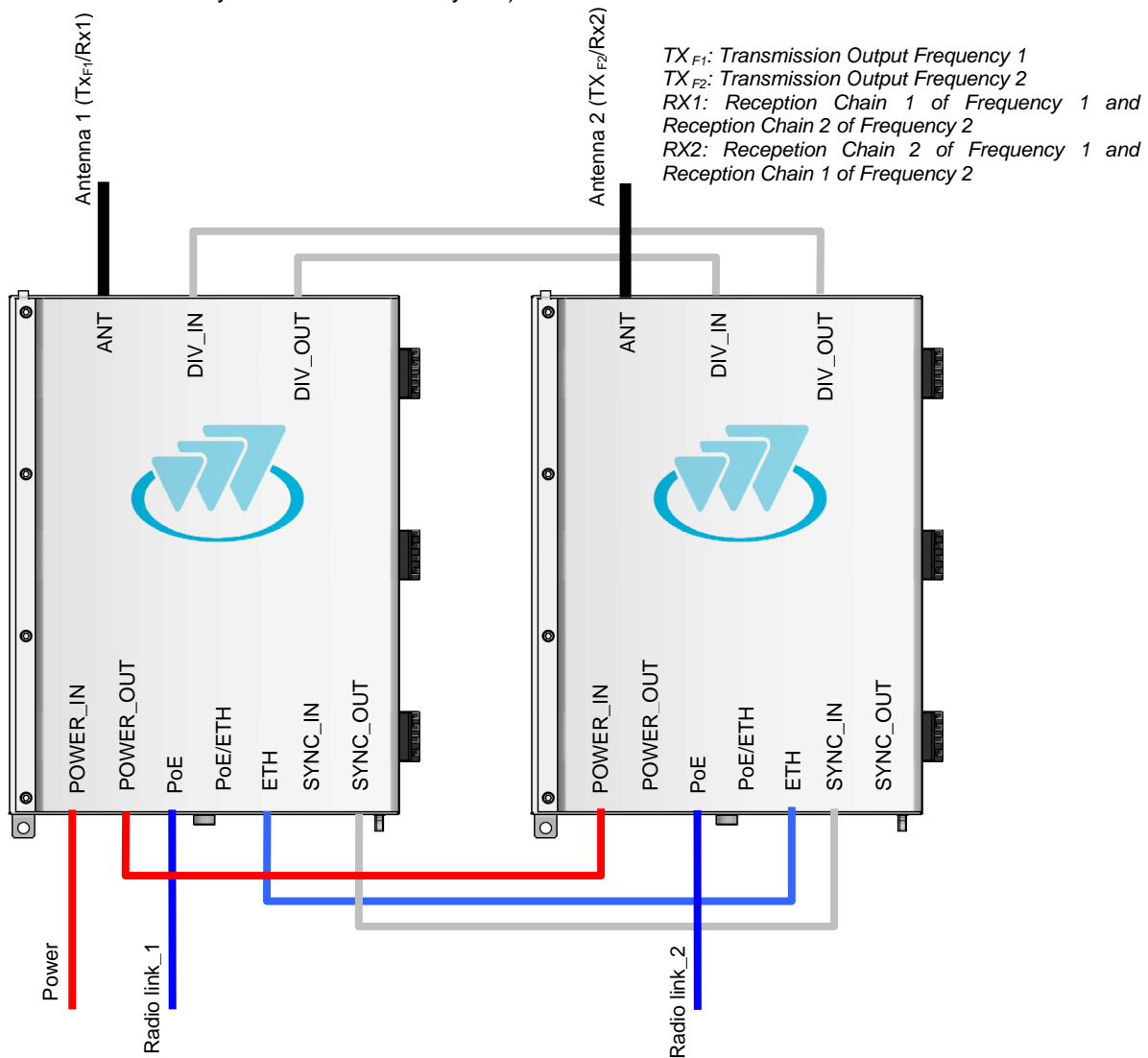

### 6.3.6.1.3.1 CONFIGURATION WITH PBS ACCESSORY

**NOTE:** Diversity 1 or 2 mode can be selected from the NMS client.

The connections are the following ones:

- ❑ Power supply for the PBS Accessories 1 and 2: 220/110 VAC or 24 VDC.
- ❑ From **ANT** connector of the PBS Accessory 1 to the first antenna.
- ❑ From **ANT** connector of the PBS Accessory 2 to the second antenna.
- ❑ Connection with radio link through **PoE** connector.

**Note 1:** The connection with the NMS Server-Client Rugged Laptop in the **PoE** connector depends of the network topology and just applies in Isolated Operation Mode of the MBS Unit.

**Note 2:** The use of the PBS accessory for two MBS Units with SNI IP option is not supported.

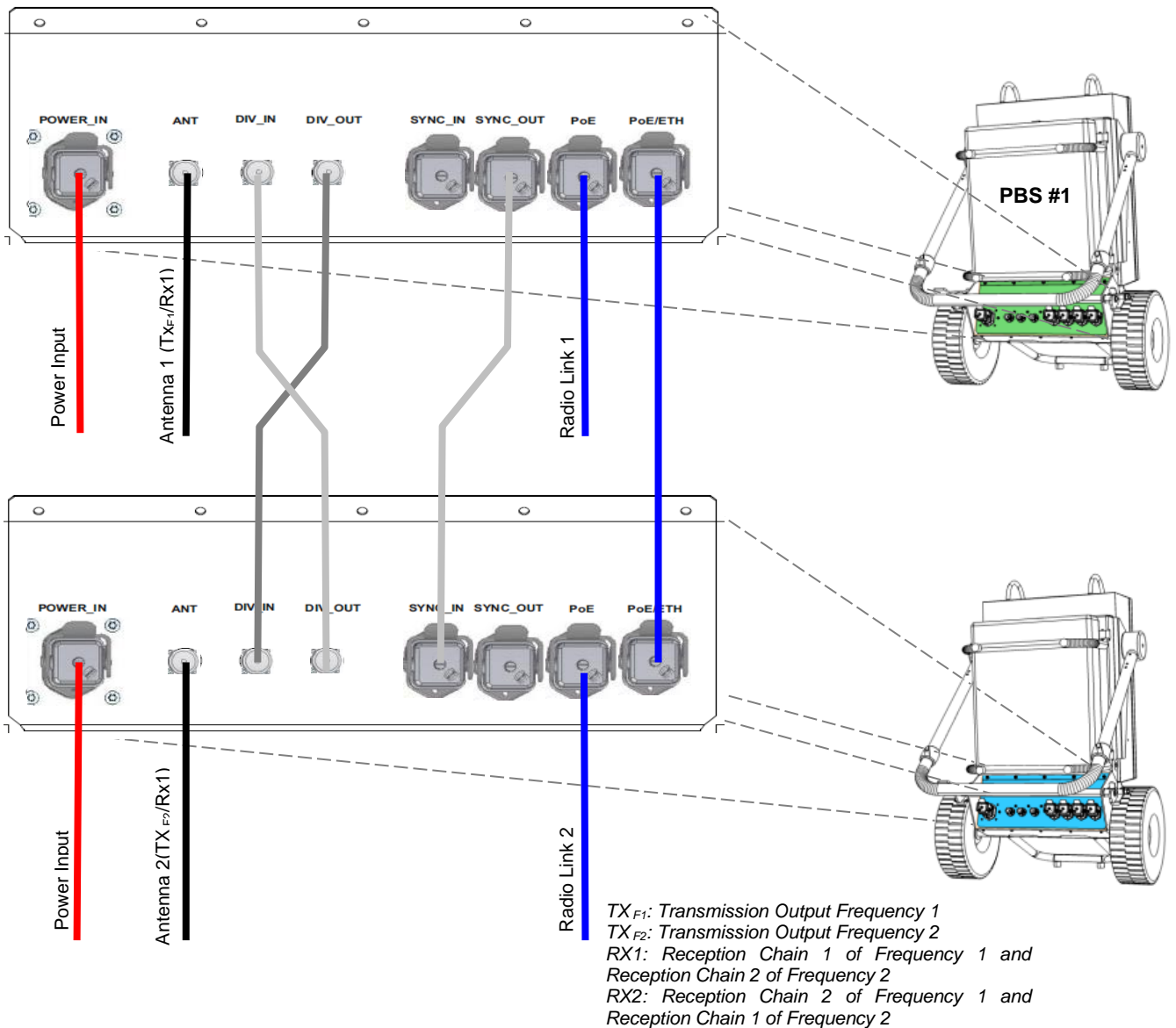



### 6.3.6.1.4 TWO MBS UNITS (DIFFERENT SUBBANDS) WITH DIVERSITY 1 IN RECEPTION

The connections are the following ones:

- ❑ Power supply for the MBS Unit 1: 220/110 VAC or 24 VDC.
- ❑ From **ANT** connector of the MBS Unit 1 to the antenna 1.
- ❑ From **ANT** connector of the MBS Unit 2 to the antenna 2.
- ❑ Connection with radio link through **PoE** connector (if the MBS Unit has SNI IP option this connector is Layer 3).
- ❑ Maintenance through **PoE/ETH** connector (if the MBS Unit has SNI IP option this connector is Layer 3 otherwise is Layer 2)

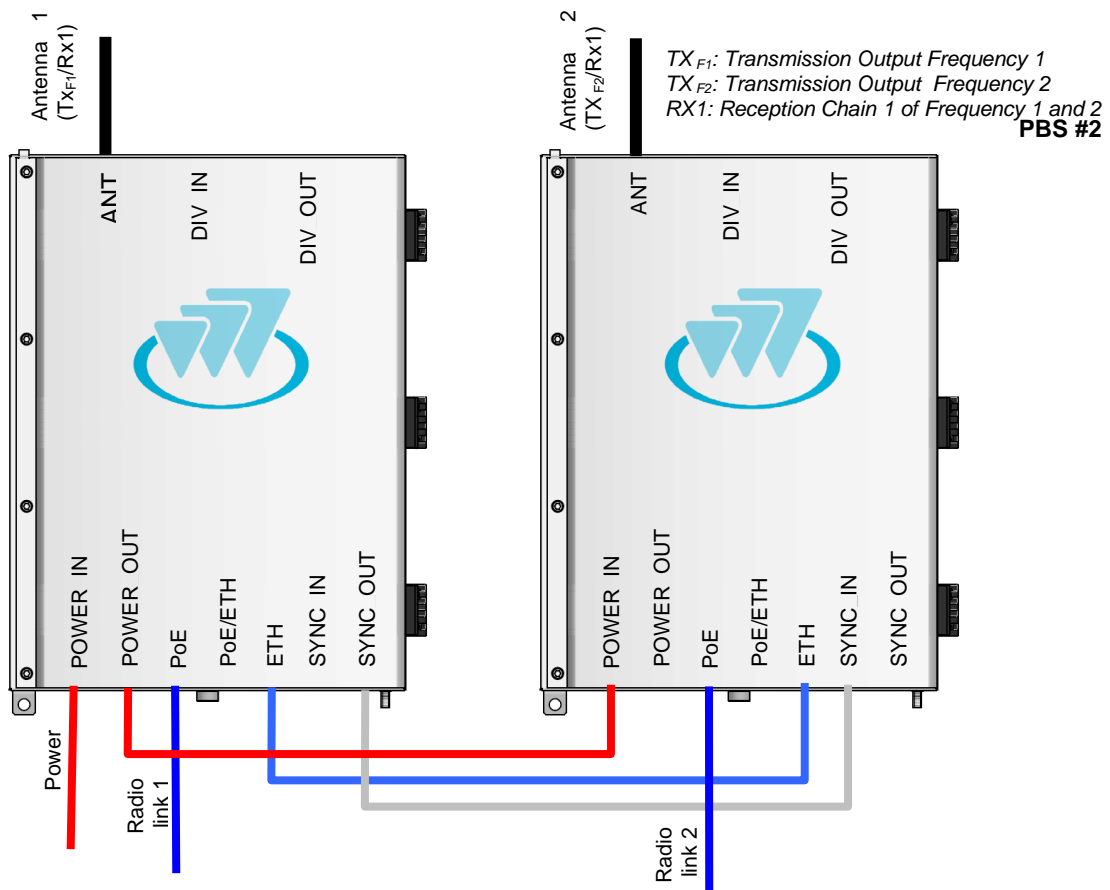

### 6.3.6.1.4.1 CONFIGURATION WITH PBS ACCESSORY

The connections are the following ones:

- ❑ Power supply for the PBS Accessories 1 and 2: 220/110 VAC or 24 VDC.
- ❑ From **ANT** connector of the PBS Accessory 1 to the antenna 1.
- ❑ From **ANT** connector of the PBS Accessory 2 to the antenna 2.
- ❑ Connection with radio link through **PoE** connector (if the MBS Unit has SNI IP option this connector is Layer 3).
- ❑ Maintenance through **PoE** connector.

**Note 1:** The connection with the NMS Server-Client Rugged Laptop in the **PoE** connector depends of the network topology and just applies in Isolated Operation Mode of the MBS Unit.

**Note 2:** The use of the PBS accessory for two MBS Units with SNI IP option is not supported.

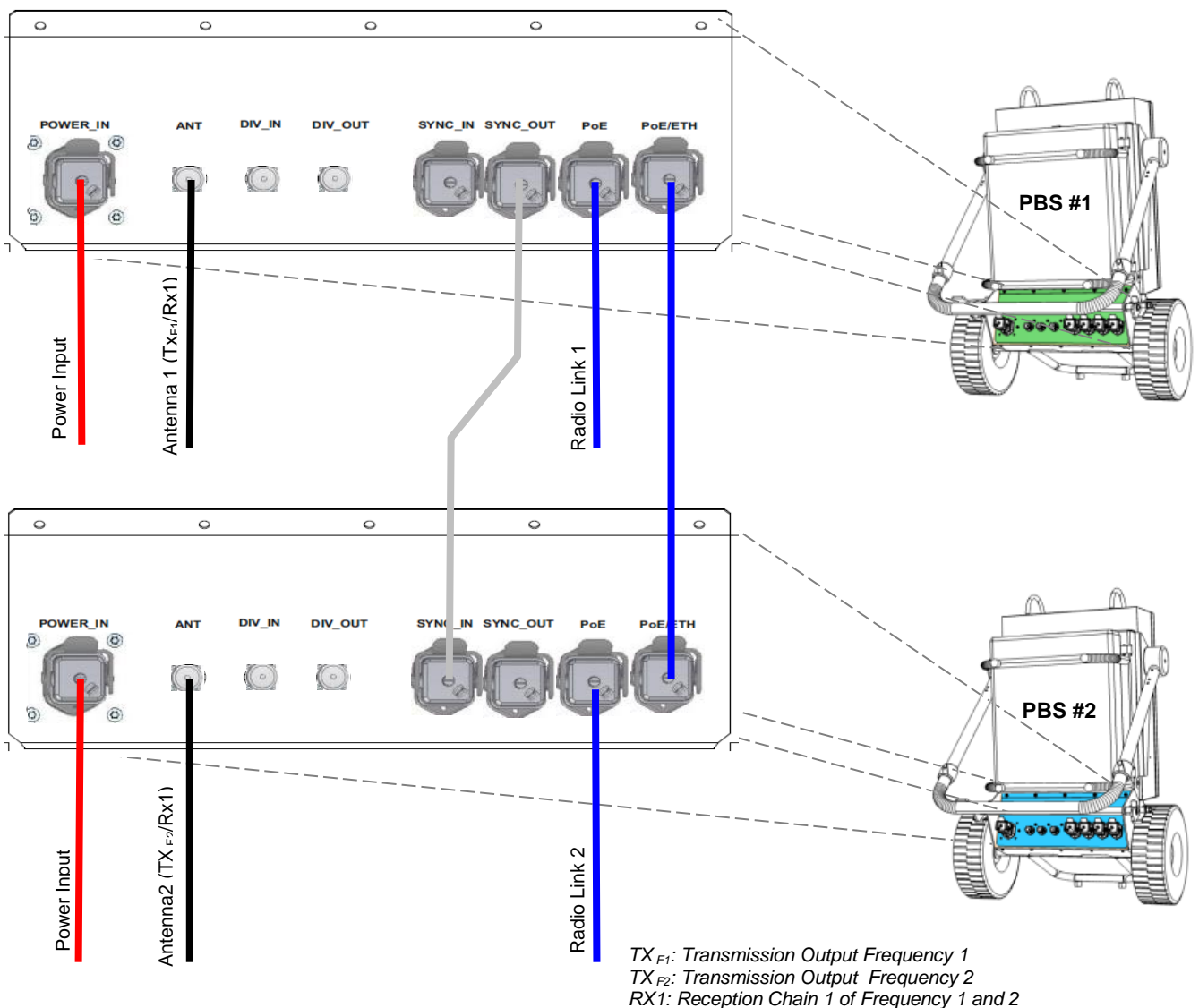

### 6.3.6.1.5 TWO MBS UNITS (DIFFERENT SUBBANDS) WITH DIVERSITY 2 IN RECEPTION

The connections are the following ones:

- ❑ Power supply for the MBS Unit 1: 220/110 VAC or 24 VDC.
- ❑ From **ANT** connector of the MBS Unit 1 to the antenna 1.
- ❑ From **DIV IN** connector of the MBS Unit 1 to the antenna 2.
- ❑ From **ANT** connector of the MBS Unit 2 to the antenna 3.
- ❑ From **DIV IN** connector of the MBS Unit 2 to the antenna 4.
- ❑ Connection with radio link through **PoE** connector (if the MBS Unit has SNI IP option this connector is Layer 3).
- ❑ Maintenance through **PoE/ETH** connector (if the MBS Unit has SNI IP option this connector is Layer 3 otherwise is Layer 2)

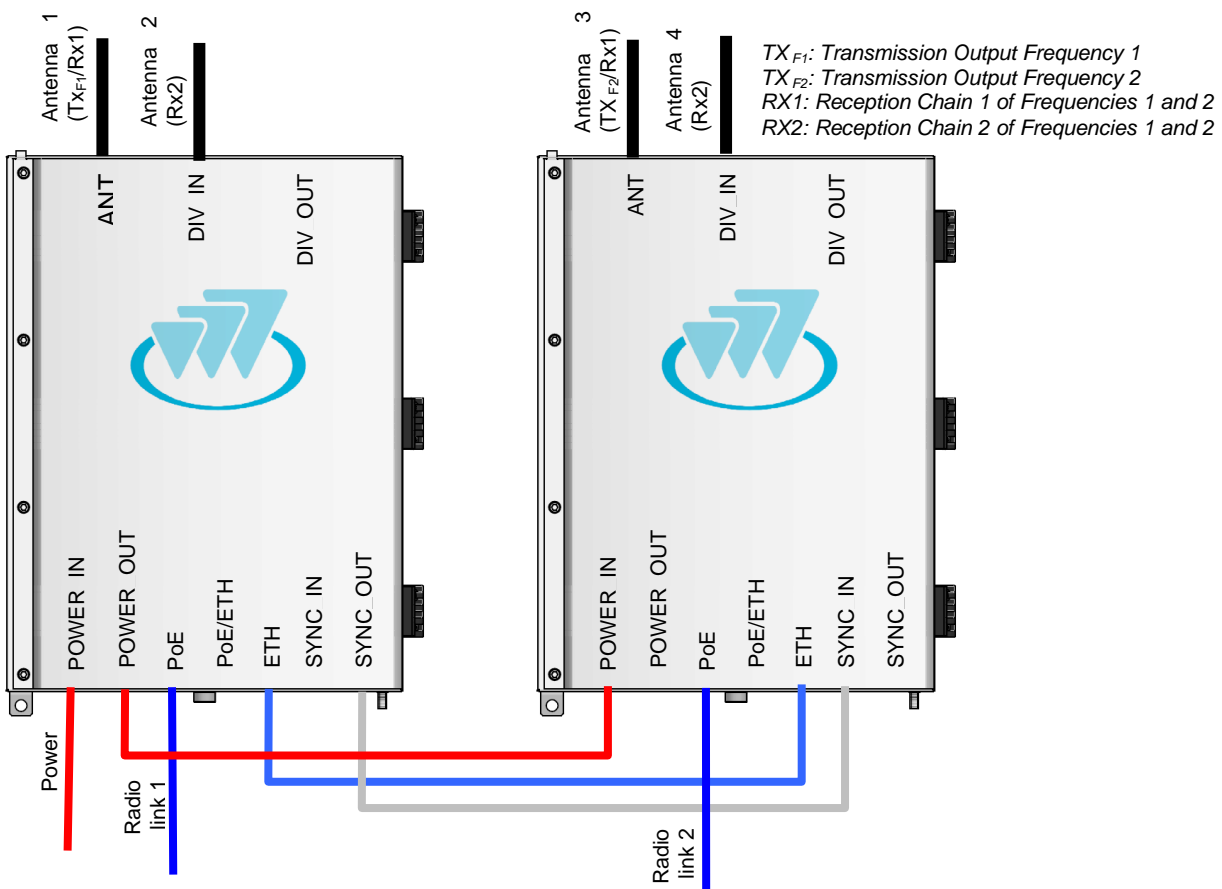

### 6.3.6.1.5.1 CONFIGURATION WITH PBS ACCESSORY

The connections are the following ones:

- ❑ Power supply for the PBS Accessories 1 and 2: 220/110 VAC or 24 VDC.
- ❑ From **ANT** connector of the PBS Accessory 1 to the antenna 1.
- ❑ From **DIV IN** connector of the PBS Accessory 1 to the antenna 2.
- ❑ From **ANT** connector of the PBS Accessory 2 to the antenna 3.
- ❑ From **DIV IN** connector of the PBS Accessory 2 to the antenna 4.
- ❑ Connection with radio link through **PoE** connector (if the MBS Unit has SNI IP option this connector is Layer 3).
- ❑ Maintenance through **PoE/ETH** connector.

**Note 1:** The connection with the NMS Server-Client Rugged Laptop in the **PoE** connector depends of the network topology and just applies in Isolated Operation Mode of the MBS Unit.

**Note 2:** The use of the PBS accessory for two MBS Units with SNI IP option is not supported.

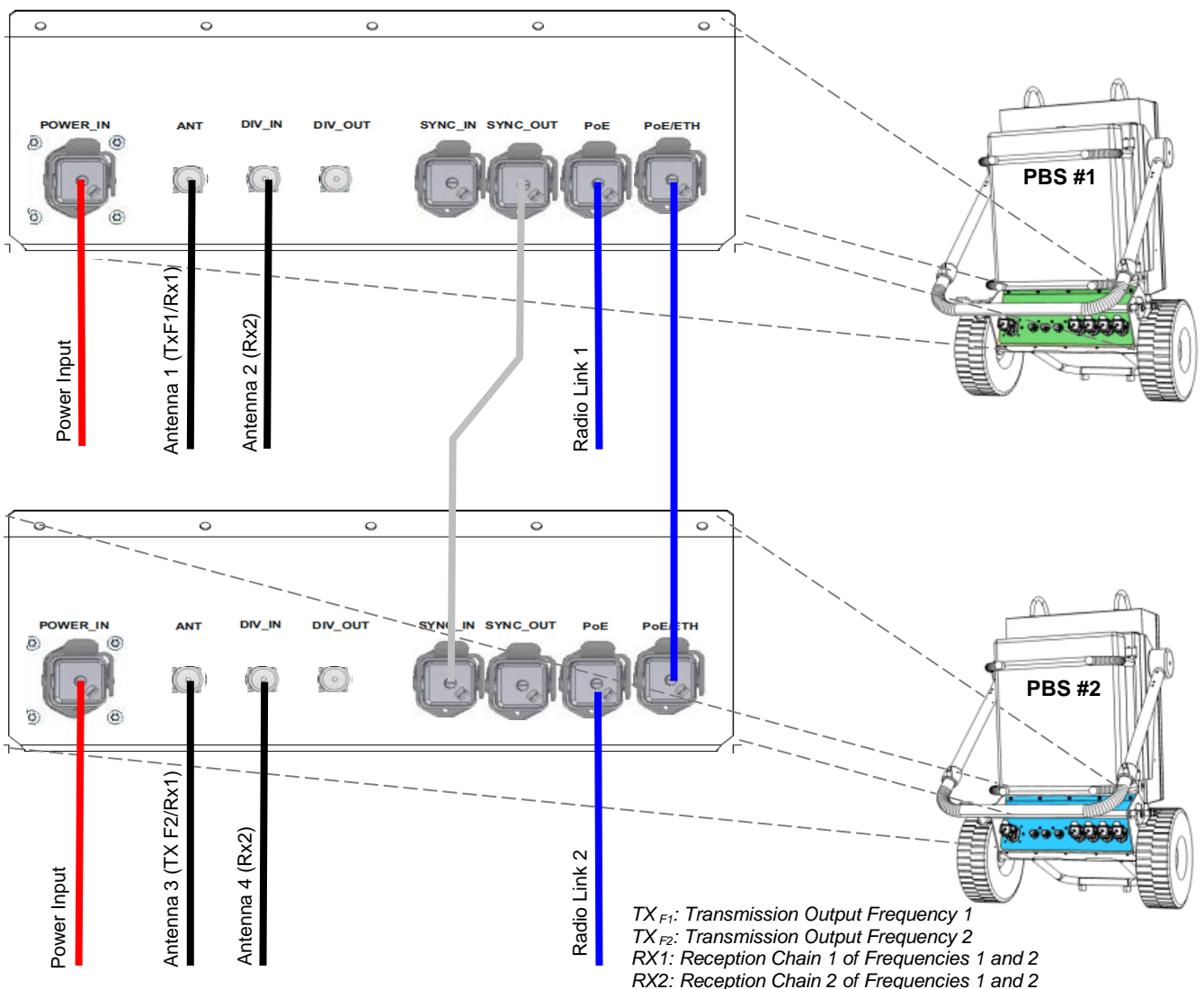

### 6.3.6.2 CONNECTION OF THE EXTERNAL POWER SUPPLY



Check that the power supply source and/or the battery to be used are adapted to the type of MBS Unit (AC/DC) and meets the voltage and current requirements necessary to supply the equipment.

#### MBS Unit with AC power supply source:

- Nominal voltage: 110/220 VAC (Range: from 94 to 264 VAC).
- Use the power cable connector provided with the MBS Unit to connect the MBS Unit to the power supply source. Use a cable of 3 wires; with weather protection; with the following features:
  - Cable diameter: 0.24 in - 0.47 in.
  - Cable section: 2.5 mm<sup>2</sup> (AWG 13) (0.6/1KV)
  - UL VW-1 certified power supply cable is needed.
- Ensure that the connection is made in the correct way (Line, Neutral and Earth) following the next steps:
  - Strip cable and wires (stripping length 0.31 in - 0.35 in).

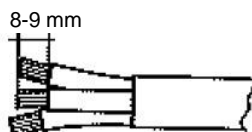

NOTE: The earth cable must be 0.08 in longer.

- Push the cable through the cable gland and the hood/housing and insert the wires into the insert respecting the correct polarity.

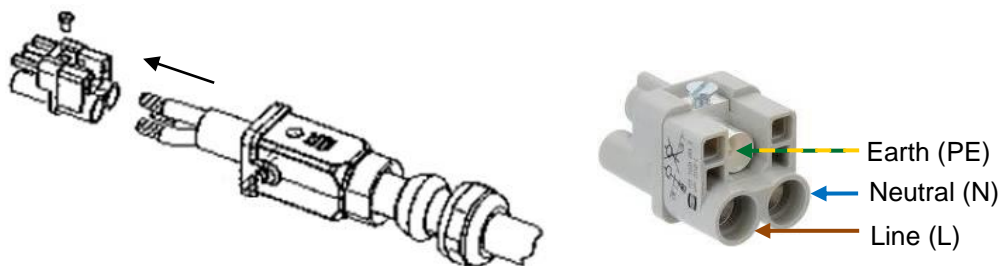

- Fix each wire tightening each pin from the front side with a hexagonal screwdriver (Allen number 2).

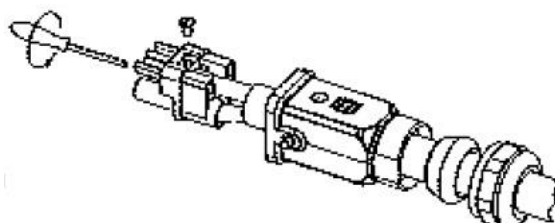

- Push the insert back into the hood/housing.

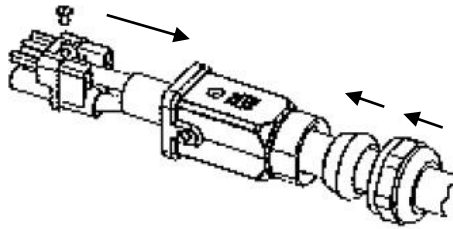

- Fix the assembly tightening the top locking screw and tightening the cable gland nut on the back of the hood/housing.

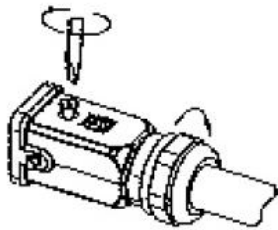

#### MBS Unit with DC power supply source:

- Nominal voltage: 24 VDC (Range: from 21.6 to 31.2 VDC).
- Use the power cable connector provided with the MBS Unit to connect the MBS Unit to the power supply source. Use a cable of 3 wires with weather protection and the following features:
  - Cable diameter: 0.39 in - 0.55 in.
  - Cable section: 6 mm<sup>2</sup> (AWG 9) (0.6/1KV).
  - Maximum cable length<sup>1</sup>:
    - One MBS Unit: 92.96 yd
    - Two MBS Units: 45.93 yd
  - UL VW-1 certified power supply cable is needed
- Ensure that the connection is made in the correct way (Positive, Negative and Earth) following the next steps:
  - Strip cable and wires (stripping length 0.31 in - 0.35 in).

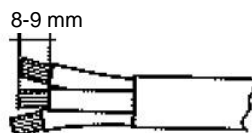

NOTE: The Earth cable must be 0.08 in longer.

<sup>1</sup> The greater the cable length, the greater the voltage drop in it. The specified length has been calculated to ensure minimum operating voltage of the MBS Unit, assuming a minimum voltage of 24V at the output of the power system and a typical resistivity of copper wire  $\leq 0.0172 \Omega \text{ mm}^2/\text{m}$

- Push the cable through the cable gland and the hood/housing and insert the wires into the insert respecting the correct polarity.

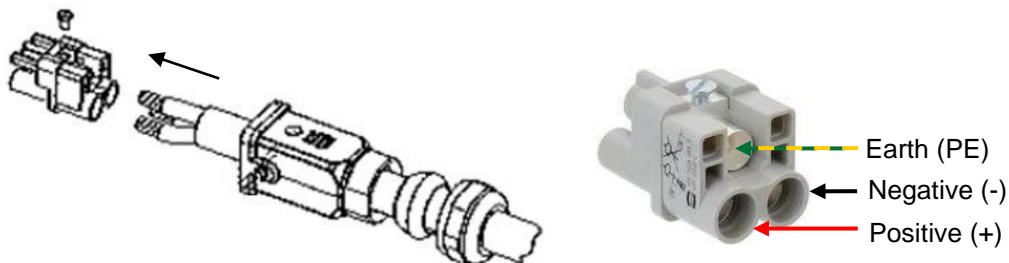

- Fix each wire tightening each pin from the front side with a hexagonal screwdriver (Allen number 2).

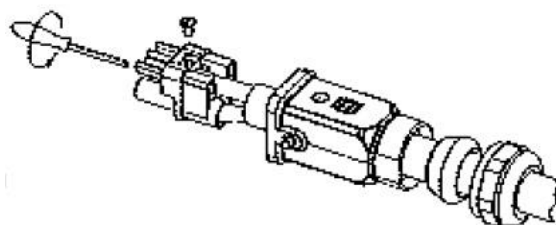

- Push the insert back into the hood/housing.

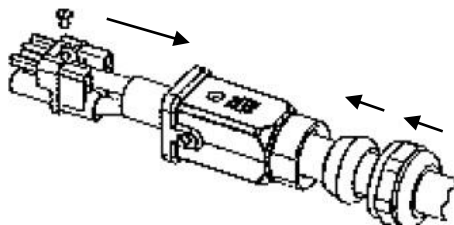

- Fix the assembly tightening the top locking screw and tightening the cable gland nut on the back of the hood/housing.

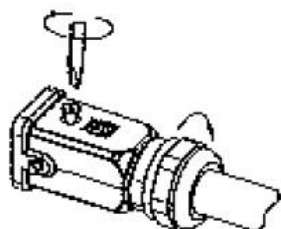

**In both cases:**

- ❑ The power supply cable to the MBS Unit must be provided by the installer with the proper power supply connector adapted for the connection to the electrical network or to a 24 VDC source.
- ❑ Ensure that the earth connection is made before equipment's start-up. The MBS Unit has an earth connector; this connector will connect to the earth protection of the installation, which is different to the earth protection of the lightning rod.

Make this connection with a cable of, at least, 25 mm<sup>2</sup> (AWG 3) section

**NEVER** use a gas or electricity conduit as an earth.

**6.3.6.3 ANTENNA CONNECTION**

- ❑ With every MBS Unit, a RF super-flexible wire, N-Male – N-Male, is supplied to connect the **ANT** connector of the MBS Unit with the RF wire of the antenna.

**Note:** In case of installation a MBS Unit with diversity 2, it is recommended to contact your supplier and/or installer who will provide the additional RF super-flexible wire (Cod. 208931).

- ❑ The RF assembly depends on the cable type used in the installation up to the antenna.
- ❑ The RF cable must have a protection against water entry (vulcanizable tape).
- ❑ Choose the most adaptable antenna for the installation. The antenna must have an impedance of 50 ohms to the equipment transmission frequency. Install the antenna in accordance with the manufacturer's instructions.
- ❑ Use a coaxial cable, avoiding as much as possible large cable lengths. Cable impedance is 50 ohms.
- ❑ In installations with diversity, the greatest gain is achieved by placing the antennas on the same horizontal plane with a minimum distance of 6.01 yd between them.
- ❑ Measure the ROE of the installation. Never accept a ROE greater than 2









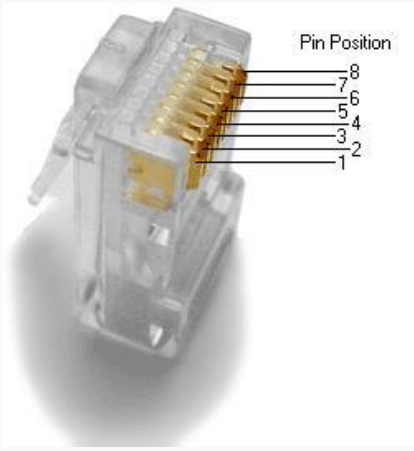

#### 6.3.6.4 EXTERNAL ETHERNET CONNECTION

- ❑ The Ethernet cable connector, to connect the MBS Unit with the radio link (PoE), is supplied with every MBS Unit.

**Note:** In the case of connection to two radio links, it is recommended to contact your supplier and/or installer who will provide the additional Ethernet cable connector.

- ❑ The Ethernet wire for the radio link connections is supplied by the installer, and must have the following characteristics:
  - Cable with 8 wires, SF/UTP cat5E with outdoor protection.
  - Diameter: 0.26 in to 0.37 in.
  - Maximum length: 109.36 yd
  - Mount the wire on the connector according to the TIA / EIA 568B standard (The assembly requires no tools, is done manually).

Pin	Color T568B	Pins on plug face (socket is reversed)
1	 White/Orange	
2	 Orange	
3	 White/Green	
4	 Blue	
5	 White/Blue	
6	 Green	
7	 White/Brown)	
8	 Brown	

### **6.3.7 CONNECTING / DISCONNECTING THE MBS AC MAINS SUPPLY**

The electrical supply to the MBS is connected through a connector with a three-wire cable.

This cable shall be connected to the electrical supply network, which must comply with the standards and/or regulations of the country in which the MBS is installed.

The connection of the MBS to the electrical installation must be carried out by specialised personnel.

The maximum current required by the MBS is 1 A at 220-240 V AC or 2 A at 100-130 V AC

The electrical installation to which the MBS is connected must comply with the current standards for electrical installations in the country in which the MBS is installed. The nominal phase current of the MBS is 2 A at 110 V AC and 1 A at 220 V AC

The MBS requires the following external protection devices:

1. A 2-pole overcurrent protection device rated 1 A for 230 VAC power supply or 2 A for 110 VAC power supply (when two MBS Units are supplied using the same overcurrent protection device, the ratings will be 2 A for 230 VAC or 4 A for 110 VAC). This device shall be in accordance with the country regulations.

Only for USA and Canada: this over-current protection device shall be UL listed and CSA certified.

2. Earth leakage protection using a residual current device with a sensitivity of 30 mA.

The MBS must be connected to earth as described in this Installation Guide.

The MBS can be disconnected by unplugging the aerial power connector, after disconnecting the aerial power supply connector.

### **6.3.8 CONNECTING / DISCONNECTING THE MBS FROM THE DC SUPPLY**

The electrical supply to the MBS is connected through a connector with a three-wire cable.

This cable shall be connected to the 24 VDC supply, which must comply with the regulations of the country in which the MBS is installed.

The connection of the MBS to the supply must be carried out by specialised personnel.

The maximum current required by the MBS is 9 A.

The MBS requires a 2-pole external overcurrent protection devices rated 9 A (when two MBS Units are supplied using the same overcurrent protection device, the rating will be 18 A). This device shall be in accordance with the country regulations.

Only for USA and Canada: this over-current protection device shall be UL listed and CSA certified.

The MBS must be connected to earth as described in this Installation Guide.

The MBS can be disconnected by unplugging the power connector after disconnecting the power supply.

## 7. START UP/CONFIGURATION/VERIFICATION



**IMPORTANT:** Ensure that the power supply of the MBS Unit is the proper one before switch it on; an erroneous power supply can cause damages in the equipment.

Every MBS Unit has in its labelling the diverse options that it offers. If the MBS Unit includes the option **O148017PT**, this it will have to be powered with AC (220/110 VAC), however, if the MBS Unit includes the option **O148018PT** it will have to be powered with +24 VDC nominal voltage.

Preliminary considerations for carrying out the MBS Unit start up:

- To start up the equipment, this must have the final IP correctly configured (see chapter of infrastructure configuration (F067220PT) in the Technical Manual).
- Refer to the radio link used to configure this device. Make sure this element is properly connected to ground.

The steps to perform the final settings are:

1.	Before connecting power supply to the MBS Unit, make sure the right voltage level reaches the power supply cable connector.
2.	Provide power to the MBS Units through the <b>POWER_IN</b> connector.
3.	Wait for the MBS Unit initialization (about 3 minutes).
4.	Verify that you have access to the MBS (by performing a "ping"). Make partial checks in case of no response from the MBS, perform pings to intermediate elements: SNI → Node radio link → remote site radio link → MBS.
5.	From NMS, register the MBS Unit(s), completing the necessary settings (see chapter of infrastructure configuration, F067220PT, and the client's user manual NMS, F067201PT).
6.	Verify the absence of alarms in monitoring module and check with a radio terminal that it is registered and you can make and receive calls. In case of interference or coverage fault alarms see chapter of the infrastructure adjustment (F067218PT).

## 8. INCIDENTS



The MBS Unit must be repaired by authorized technical personnel only. There will not be performed any repair of the MBS Unit and it will have to be sent to factory except for the change of the pressure equalizer or the overvoltage protections.

### 8.1 INTERFERENCE AT MBS UNIT

This alarm is monitored in the NMS management and configuration module. See the infrastructure Event List in the NMS Client Help contents.

Any interference in the MBS Unit is activated when there are a large number of consecutive reception faults in the MBS Unit. A reception fault is considered when a level higher than the threshold for reception of the carrier, but is not recognized as valid TETRA signal. Depending on the signal level, interference is considered low or high. So, if the level of signal is above the threshold for reception and below the threshold set to high interference and is not recognized as a valid sign, it will be a low interference alarm. If the signal level is above the threshold set to high interference and is not recognized as a valid signal, the low level alarm would disappear (if it happened) and high interference would produce.

These alarms are turned off when the interference source disappears or with any right TETRA reception for low interference case, and with more than one consecutive right reception for high-level interference.

## 8.2 OVER VOLTAGE PROTECTION

MBS Unit has several protections against lightning and surges, in any case the action of these protections generate an alarm in the NMS client which disappear when the protective element is replaced by authorized technical staff.

### Protection against lightning and power surges

- ❑ This protection is located within the MBS Unit. It should be changed every time it breaks even if the MBS Unit continues functioning properly. An alarm in the NMS Client is reported showing that the replacement of this type of protection is needed.

### Protection against lightning and surges in the RF connections

- ❑ RF surge protection consists of replaceable Gas Discharge Tubes (GDT) located into the RF connectors located in the bottom of the MBS. Without GDT no protection is provided and VSWR performance is degraded.
- ❑ The GTD is removable, making easy and quick replacing if it is damaged. The replacing intervals depend mainly upon the number and the strength of the lightning impacts but as a general rule, must be changed after that a lightning has destroyed some elements ahead (e.g. antenna). That is why the GTD rarely must be replaced in most use cases and life expectancy can be up to 20 years.
- ❑ GDT is connected in parallel between the central conductor and the external shield. During an overvoltage (lightning), the tube is practically shorted and avoids overvoltage input into the MBS. When the overvoltage disappears, GTD returns to its original condition of high insulation and is ready to operate again.
- ❑ While GTD is triggered (during lightning), the MBS may appear alarmed in the NMS client software (alarm monitoring of the system).