

FCC RF Test Report

APPLICANT : Doro AB
EQUIPMENT : GSM Tri-band Digital Mobile Telephone
BRAND NAME : Doro
MODEL NAME : Doro PhoneEasy 410gsm
FCC ID : WS5DORO410G
STANDARD : FCC Part 15 Subpart C §15.247
CLASSIFICATION : Digital Spread Spectrum (DSS)

The product was received on May 25, 2009 and completely tested on Jun. 03, 2009. We, SPORTON INTERNATIONAL (KUNSHAN) INC., would like to declare that the tested sample has been evaluated in accordance with the procedures given in ANSI C63.4-2003 and shown compliance with the applicable technical standards.

The test results in this report apply exclusively to the tested model / sample. Without written approval of SPORTON INTERNATIONAL (KUNSHAN) INC., the test report shall not be reproduced except in full.

Reviewed by:

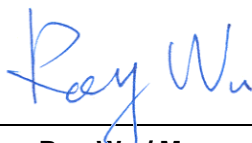

Roy Wu / Manager



SPORTON INTERNATIONAL (KUNSHAN) INC.
No. 3-2, PingXiang Road, Kunshan, Jiangsu Province, P.R.C.



TABLE OF CONTENTS

REVISION HISTORY..... 3

SUMMARY OF TEST RESULT 4

1 GENERAL DESCRIPTION..... 5

 1.1 Applicant 5

 1.2 Manufacturer..... 5

 1.3 Feature of Equipment Under Test 5

 1.4 Testing Site 6

 1.5 Applied Standards 7

 1.6 Ancillary Equipment List 7

2 TEST CONFIGURATION OF EQUIPMENT UNDER TEST..... 8

 2.1 Test Mode 8

 2.2 Connection Diagram of Test System 9

 2.3 RF Utility 9

3 TEST RESULT 10

 3.1 Number of Channel Measurement 10

 3.2 20dB Bandwidth Measurement 12

 3.3 Hopping Channel Separation Measurement 15

 3.4 Dwell Time Measurement 18

 3.5 Peak Output Power Measurement 20

 3.6 Band Edges Measurement 23

 3.8 AC Conducted Emission Measurement..... 27

 3.9 Radiated Emission Measurement..... 31

 3.10 Antenna Requirements 40

4 LIST OF MEASURING EQUIPMENT 41

5 UNCERTAINTY OF EVALUATION..... 42

6 CERTIFICATION OF TAF ACCREDITATION 44

APPENDIX A. PHOTOGRAPHS OF EUT

APPENDIX B. SETUP PHOTOGRAPHS



SUMMARY OF TEST RESULT

Report Section	FCC Rule	IC Rule	Description	Limit	Result	Remark
3.1	15.247(b)(1)	A8.4(2)	Number of Channels	≥ 15Chs	Pass	
3.2	15.247(a)(1)	A8.1(a)	20dB Bandwidth	NA	Pass	-
3.3	15.247(a)(1)	A8.1(b)	Channel Separation	≥ 2/3 of 20dB BW	Pass	-
3.4	15.247(a)(1)	A8.1(d)	Dwell Time of Each Channel	≤ 0.4sec in 31.6sec period	Pass	-
3.5	15.247(a)(1)	A8.1(b)	Peak Output Power	≤ 1W	Pass	-
3.6	15.247(d)	A8.5	Frequency Band Edges	≤ 20dBc	Pass	-
3.7	15.207	Gen 7.2.2	AC Conducted Emission	15.207(a)	Pass	Under limit 6.83 dB at 0.47 MHz
3.8	15.247(d)	A8.5	Transmitter Radiated Emission	15.209(a) & 15.247(d)	Pass	Under limit 3.37 dB at 2483.50 MHz
3.9	15.203 & 15.247(b)	A8.4	Antenna Requirement	N/A	Pass	-

1 General Description

1.1 Applicant

Doro AB

Magistratsvägen 10 SE-226 44 Lund Sweden

1.2 Manufacturer

CK TELECOM LTD.

Technology Road, High-Tech Development Zone, Heyuan, Guangdong, P.R.China

1.3 Feature of Equipment Under Test

Product Feature & Specification	
Equipment	GSM Tri-band Digital Mobile Telephone
Brand Name	Doro
Model Name	Doro PhoneEasy 410gsm
FCC ID	WS5DORO410G
Tx/Rx Frequency Range	2400 MHz ~ 2483.5 MHz
Number of Channels	79
Carrier Frequency of Each Channel	2402+n*1 MHz; n=0~78
Channel Spacing	1 MHz
Maximum Output Power to Antenna	0.55 dBm (1.14 mW)
Antenna Type	PCB Antenna with gain -2 dBi
Antenna Connector Type	N/A
HW Version	SHELL-V1.0
SW Version	SHELL_S02_DORO410_L14EN_200_090525_MCP128+32_BT_FM
Type of Modulation	GFSK
EUT Stage	Identical Prototype

Remark:

1. For other wireless features of this EUT, test report will be issued separately.
2. This test report recorded only product characteristics and test results of Digital Spread Spectrum (DSS).

List of Accessory:

Specification of Accessory		
AC Adapter	Brand Name	Doro
	Model Name	HKC0055365-2A
	Power Rating	I/P:100-240Vac, 50-60Hz, 0.2A; O/P: 5.3Vdc, 650mA
	AC Power Cord Type	1.56 meter non-shielded cable without ferrite core
Battery	Brand Name	Doro
	Model Name	Care Clamshell
	Power Rating	3.7Vdc, 800mAh
	Type	Li-ion
LCD Panel	Brand Name	TRULY
	Model Name	TFT1P4448-E

Remark:

1. The above EUT's information was declared by manufacturer. Please refer to the specifications or user's manual for more detailed description.
2. For accessories equipped with this EUT, please refer to the appendix of the external photo.

1.4 Testing Site

Test Site	SPORTON INTERNATIONAL (KUNSHAN) INC.
Test Site Location	No. 3-2, PingXiang Road Kunshan, Jiangsu Province, P.R.C. TEL: +86-0512-5790-0158 FAX: +86-0512-5790-0958
Test Site No.	Sporton Site No. CO01-KS ; 03CH01-KS



1.5 Applied Standards

According to the specifications of the manufacturer, the EUT must comply with the requirements of the following standards:

- ♦ FCC Part 15 Subpart C §15.247
- ♦ FCC Public Notice DA 00-705
- ♦ ANSI C63.4-2003
- ♦ IC RSS-210 Issue 7

Remark:

1. All test items were verified and recorded according to the standards and without any deviation during the test.
2. This EUT has also been tested and complied with the requirements of FCC Part 15, Subpart B (DoC), recorded in a separate test report.

1.6 Ancillary Equipment List

Item	Equipment	Trade Name	Model Name	FCC ID	Data Cable	Power Cord
1.	System Simulator	R&S	CMU 200	N/A	N/A	Unshielded, 1.8 m
2.	Bluetooth Earphone	Nokia	HS.12W	PYAHS.12W	N/A	N/A

2 Test Configuration of Equipment Under Test

2.1 Test Mode

The EUT has been associated with peripherals pursuant to ANSI C63.4-2003 and configuration operated in a manner tended to maximize its emission characteristics in a typical application. Frequency range investigated: conduction (150 kHz to 30 MHz), radiation (9 kHz to the 10th harmonic of the highest fundamental frequency or to 40 GHz, whichever is lower).

Pre-scanned tests were conducted to determine the final configuration from all possible combinations.

The following tables are showing the test modes as the worst cases and recorded in this report.

Test Cases	
Test Item	Data Rate / Modulation
	Bluetooth 1Mbps GFSK
Conducted TCs	Mode 1 : CH00_2402 MHz Mode 2 : CH39_2441 MHz Mode 3 : CH78_2480 MHz
Radiated TCs	Mode 1 : CH00_2402 MHz Mode 2 : CH39_2441 MHz Mode 3 : CH78_2480 MHz
AC Conducted Emission	Mode 1 : GSM850 Idle + BT Link + Adapter Mode 2 : GSM1900 Idle + BT Link + Adapter
Remark: The worst case of conducted emission is mode 1; only the test data of this mode was reported.	

2.2 Connection Diagram of Test System

<Conducted Emission>

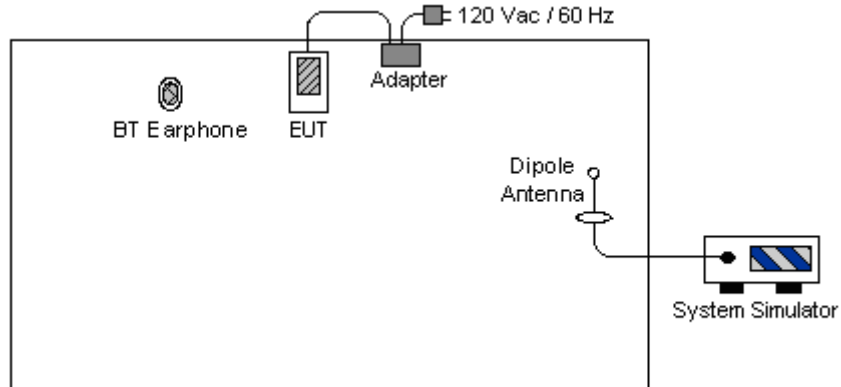

<Radiated Emission>

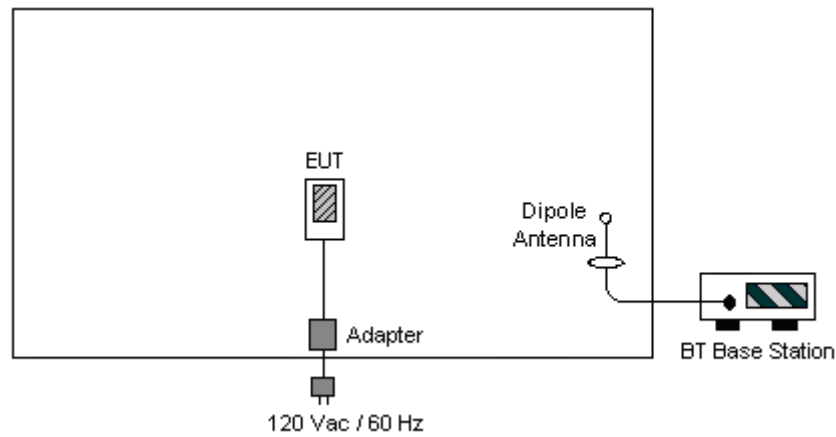

2.3 RF Utility

Enter "* # 13646633 #" in order to make the EUT into the engineering modes to contact with BT base station for continuous transmitting and receiving signals.

3 Test Result

3.1 Number of Channel Measurement

3.1.1 Limits of Number of Hopping Frequency

Frequency hopping systems in the 2400-2483.5 MHz band shall use at least 15 channels.

3.1.2 Measuring Instruments

See list of measuring instruments of this test report.

3.1.3 Test Procedure

1. The testing follows FCC Public Notice DA 00-705 Measurement Guidelines.
2. The RF output of EUT was connected to the spectrum analyzer by a low loss cable.
3. The modulation types of EUT are irrelevant to number of hopping channels deviation.
4. The EUT must have its hopping function enabled. Use the following spectrum analyzer settings:
Span = the frequency band of operation; $RBW \geq 1\%$ of the span; $VBW \geq RBW$; Sweep = auto;
Detector function = peak; Trace = max hold.
5. The number of hopping frequency used is defined as the device has the numbers of total channel.

3.1.4 Test Setup

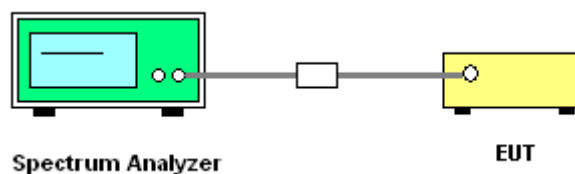

3.1.5 Test Result of Number of Hopping Frequency

Test Mode :	Mode 1~3	Temperature :	25~26°C
Test Engineer :	Rain Zhou	Relative Humidity :	44~45%
Number of Hopping Channels (Channel)		Limits (Channel)	
79		> 15	
		Pass/Fail	
		Pass	

Number of Hopping Channel Plot on Channel 00 - 78

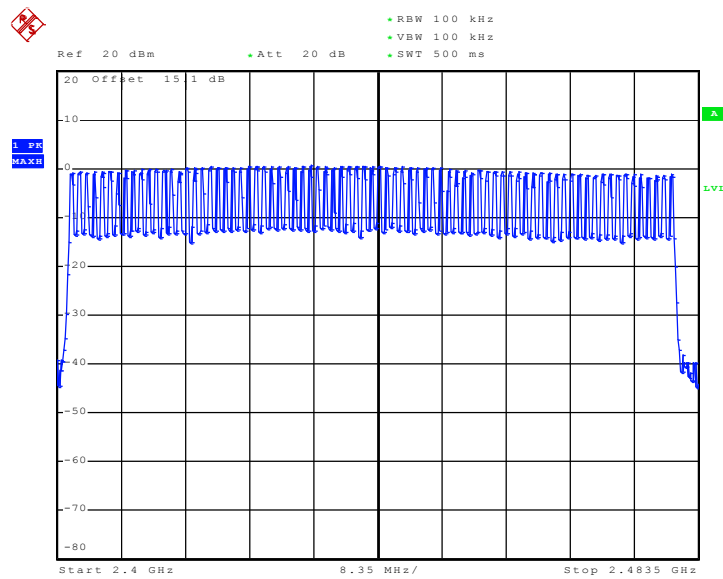

Date: 2.JUN.2009 15:55:34

3.2 20dB Bandwidth Measurement

3.2.1 Limit of 20dB Bandwidth

N/A

3.2.2 Measuring Instruments

See list of measuring instruments of this test report.

3.2.3 Test Procedures

1. The testing follows FCC Public Notice DA 00-705 Measurement Guidelines.
2. The RF output of EUT was connected to the spectrum analyzer by a low loss cable.
3. The EUT should be transmitting at its maximum data rate as the worst cases.
4. Use the following spectrum analyzer settings:
Span = approximately 2 to 3 times the 20 dB bandwidth, centered on a hopping channel;
RBW \geq 1% of the 20 dB bandwidth; VBW \geq RBW; Sweep = auto; Detector function = peak;
Trace = max hold.
5. The marker-delta reading at this point is the 20 dB bandwidth of the emission.

3.2.4 Test Setup

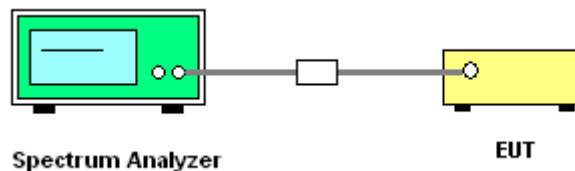

3.2.5 Test Result of 20dB Bandwidth

Test Mode :	Mode 1, 2, 3	Temperature :	25~26°C
Test Engineer :	Rain Zhou	Relative Humidity :	44~45%

Channel	Frequency (MHz)	20dB Bandwidth (MHz)
00	2402	0.834
39	2441	0.830
78	2480	0.836

20 dB Bandwidth Plot on Channel 00

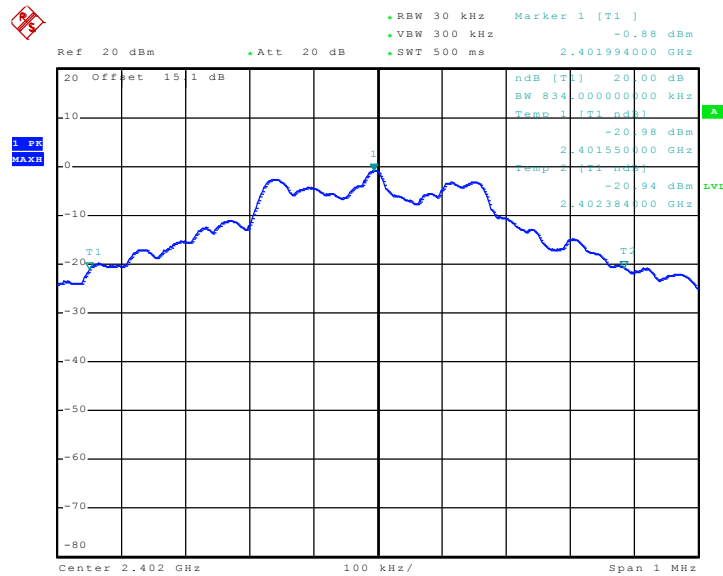

Date: 2..JUN.2009 15:40:06



20 dB Bandwidth Plot on Channel 39

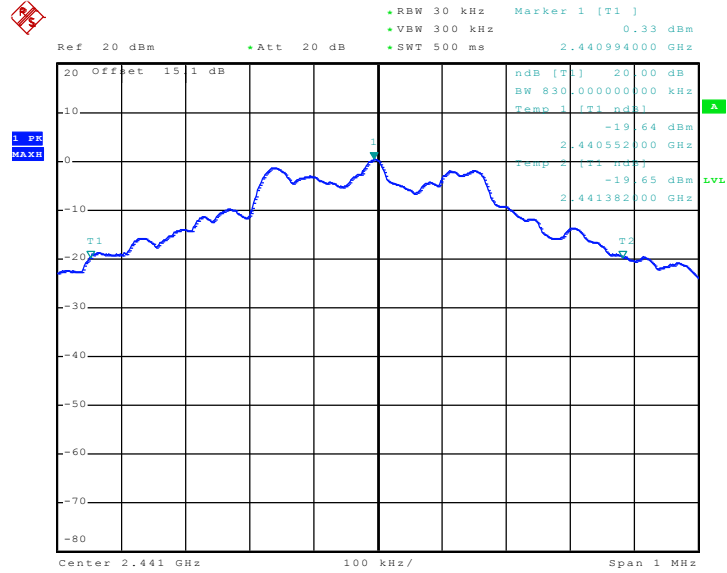

Date: 2..JUN.2009 15:40:47

20 dB Bandwidth Plot on Channel 78

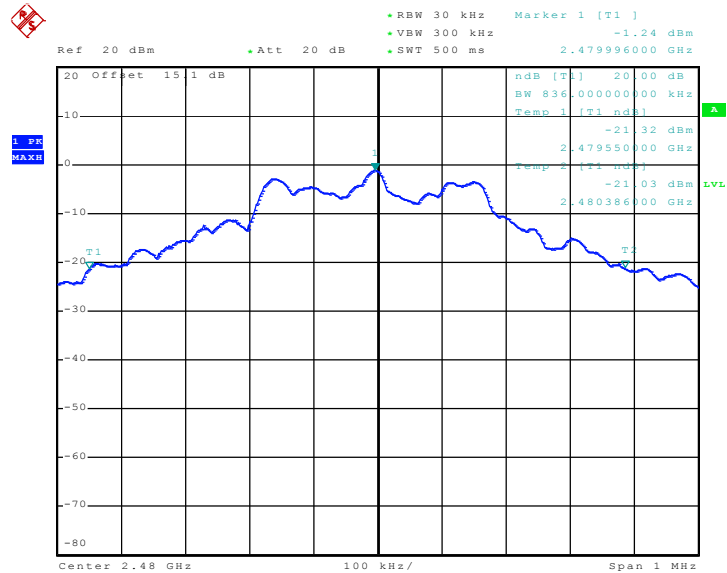

Date: 2..JUN.2009 15:41:29

3.3 Hopping Channel Separation Measurement

3.3.1 Limit of Hopping Channel Separation

Frequency hopping systems operating in the 2400-2483.5 MHz band may have hopping channel carrier frequencies that are separated by 25 kHz or two-thirds of the 20 dB bandwidth of the hopping channel, whichever is greater.

3.3.2 Measuring Instruments

See list of measuring instruments of this test report.

3.3.3 Test Procedures

1. Please refer FCC Public Notice DA 00-705 Measurement Guidelines.
2. The RF output of EUT was connected to the spectrum analyzer by a low loss cable.
3. The EUT should be transmitting at its maximum data rate as the worst cases.
4. Use the following spectrum analyzer settings:
Span = wide enough to capture the peaks of two adjacent channels; RBW \geq 1% of the span;
VBW \geq RBW; Sweep = auto; Detector function = peak; Trace = max hold.
5. Use the marker-delta function to determine the separation between the peaks of the adjacent channels.

3.3.4 Test Setup

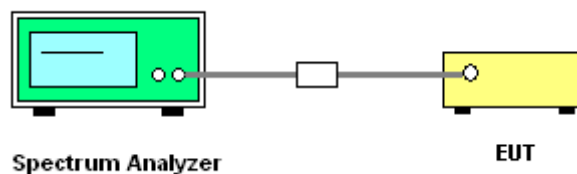



Channel Separation Plot on Channel 39 - 40

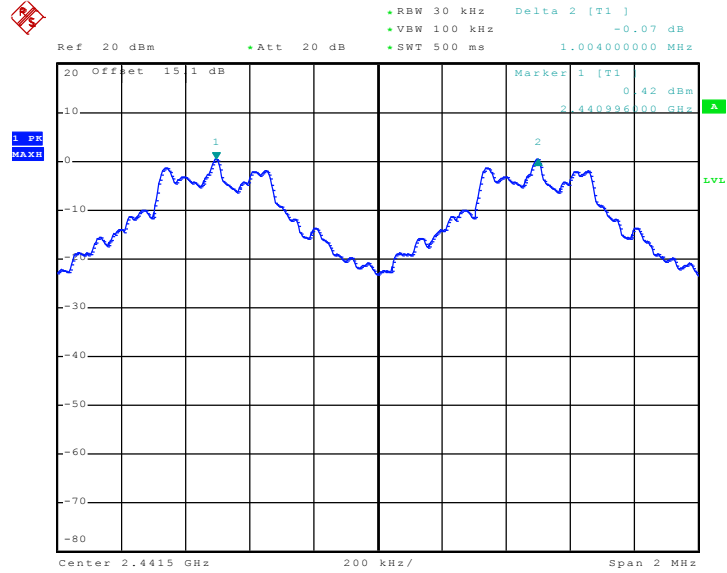

Date: 2..JUN.2009 16:55:59

Channel Separation Plot on Channel 77 - 78

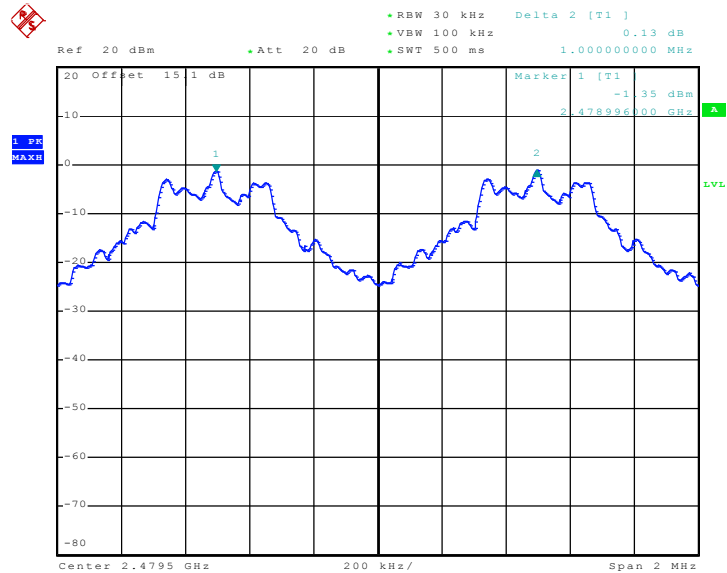

Date: 2..JUN.2009 16:58:13

3.4 Dwell Time Measurement

3.4.1 Limit of Dwell Time

The average time of occupancy on any channel shall not be greater than 0.4 seconds within a period of 0.4 seconds multiplied by the number of hopping channels employed.

3.4.2 Measuring Instruments

See list of measuring instruments of this test report.

3.4.3 Test Procedures

1. The testing follows FCC Public Notice DA 00-705 Measurement Guidelines.
2. The RF output of EUT was connected to the spectrum analyzer by a low loss cable.
3. The EUT should be transmitting at its maximum data rate as the worst cases.
4. The EUT must have its hopping function enabled. Use the following spectrum analyzer settings:
Span = zero span, centered on a hopping channel; RBW = 1 MHz; VBW ≥ RBW; Sweep = as necessary to capture the entire dwell time per hopping channel; Detector function = peak; Trace = max hold.
5. Use the marker-delta function to calculate the dwell time.

3.4.4 Test Setup

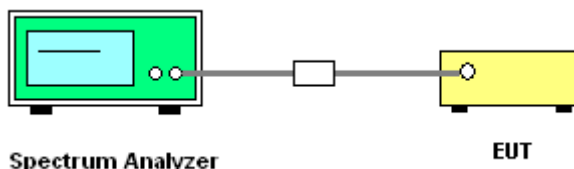

3.4.5 Test Result of Dwell Time

Test Mode :	Mode 2	Temperature :	25~26°C		
Test Engineer :	Rain Zhou	Relative Humidity :	44~45%		
Package Mode	Average Hopping Channel	Package Transfer Time (usec)	Dwell Time (sec)	Limits (sec)	Pass/Fail
DH5	3.50	3040.00	0.336	0.4	Pass

Remark:

1. Dwell Time=79(channels) x 0.4(s) x average hopping channel x package transfer time
2. 79 channels come from the Hopping Channel number.
3. Average Hopping Channel = hops/sweep time
4. t: Package Transfer Time(us)



DH1 Dwell Time (One Pulse) Plot on Channel 39

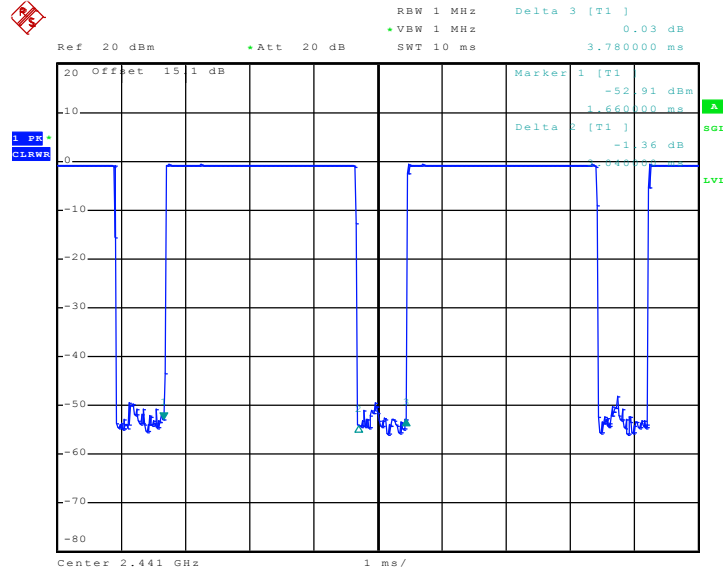

Date: 2..JUN.2009 16:11:37

DH1 Dwell Time (Count Pulses) Plot on Channel 39

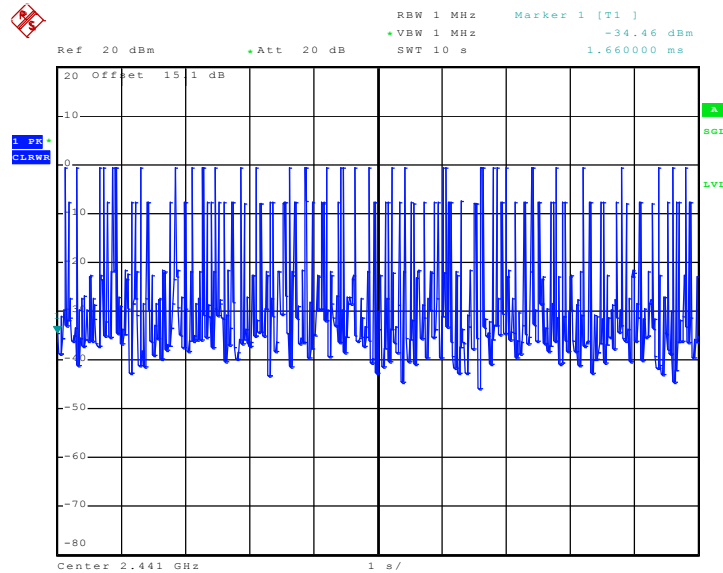

Date: 2..JUN.2009 16:14:10

3.5 Peak Output Power Measurement

3.5.1 Limit of Peak Output Power

Frequency hopping systems operating in the 2400-2483.5 MHz band employing at least 75 non-overlapping hopping channels: 1W (30 dBm).

3.5.2 Measuring Instruments

See list of measuring instruments of this test report.

3.5.3 Test Procedures

1. The testing follows FCC Public Notice DA 00-705 Measurement Guidelines.
2. The RF output of EUT was connected to the spectrum analyzer by a low loss cable.

3.5.4 Test Setup

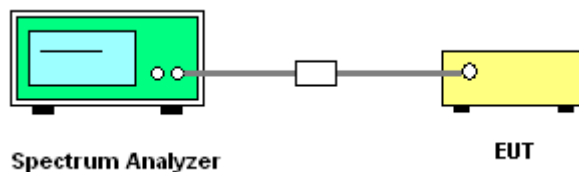

3.5.5 Test Result of Peak Output Power

Test Mode :	Mode 1, 2, 3	Temperature :	25~26°C
Test Engineer :	Rain Zhou	Relative Humidity :	44~45%

Channel	Frequency (MHz)	RF Power (dBm)		
		GFSK	Max. Limits (dBm)	Pass/Fail
		1 Mbps		
00	2402	-0.65	30	Pass
39	2441	0.55	30	Pass
78	2480	-1.01	30	Pass



Peak Output Power Plot on Channel 00

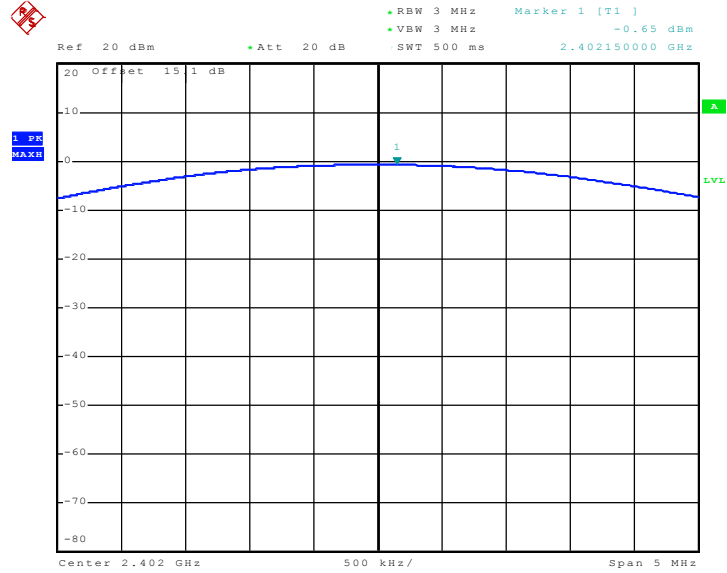

Date: 2..JUN.2009 15:16:50

Peak Output Power Plot on Channel 39

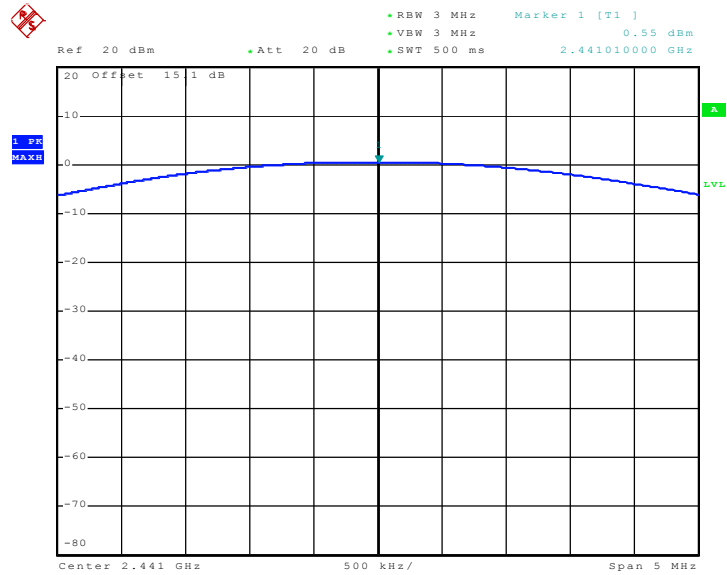

Date: 2..JUN.2009 15:18:09



Peak Output Power Plot on Channel 78

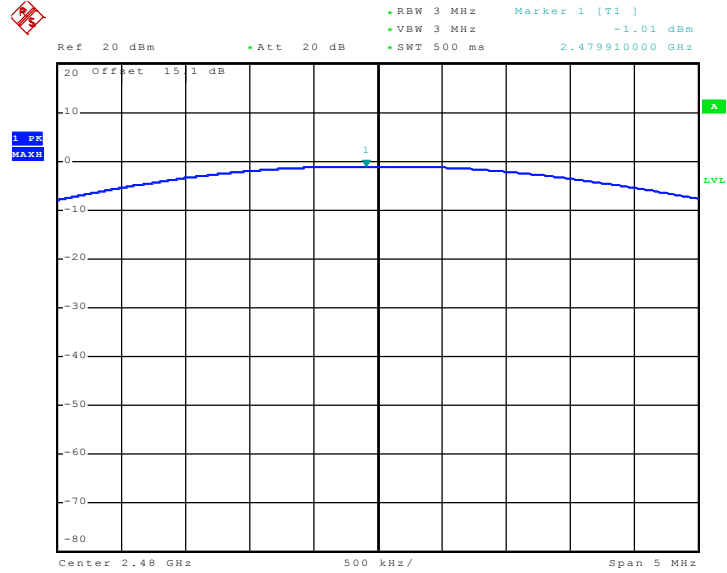

Date: 2..JUN.2009 15:19:08

3.6 Band Edges Measurement

3.6.1 Limit of Band Edges

In any 100 kHz bandwidth outside the intentional radiation frequency band, the radio frequency power shall be at least 20 dB below the highest level of the radiated power. In addition, radiated emissions which fall in the restricted bands must also comply with the radiated emission limits.

3.6.2 Measuring Instruments

See list of measuring instruments of this test report.

3.6.3 Test Procedures

1. The testing follows the guidelines in ANSI C63.4-2003 and FCC Public Notice DA 00-705 Measurement Guidelines.
2. RF antenna conducted test: Set RBW = 100 kHz, Video bandwidth (VBW) > RBW, scan up through 10th harmonic. Band edge emissions must be at least 20 dB down from the highest emission level within the authorized band as measured with a 100 kHz RBW. Note: If the device complies with the use of power option 2 the attenuation under this paragraph shall be 30 dB instead of 20 dB.
3. Radiated emission test: Applies to band edge emissions that fall in the restricted bands listed in FCC Section 15.205. The maximum permitted average field strength is listed in FCC Section 15.209. A pre-amp is necessary for this measurement. For measurements above 1 GHz, set RBW = 1MHz, VBW = 10 Hz, Sweep: Auto. If the emission is pulsed, modify the unit for continuous operation; use the settings shown above, then correct the reading by subtracting the peak-average correction factor, derived from the appropriate duty cycle calculation. See FCC Section 15.35(b) and (c).

3.6.4 Test Setup

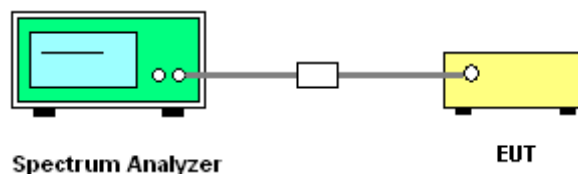



3.6.5 Test Result of Radiated Band Edges

Test Mode :	Mode 1	Temperature :	26~27°C
Test Channel :	00	Relative Humidity :	40~43%
		Test Engineer :	Alex Wang

ANTENNA POLARITY : HORIZONTAL										
Frequency (MHz)	Level (dBuV/m)	Over Limit (dB)	Limit Line (dBuV/m)	Read Level (dBuV)	Antenna Factor (dB)	Cable Loss (dB)	Preamp Factor (dB)	Ant Pos (cm)	Table Pos (deg)	Remark
2338.00	54.17	-19.83	74.00	54.41	31.72	3.21	35.17	100	0	Peak
2338.00	38.67	-15.33	54.00	38.91	31.72	3.21	35.17	100	360	Average

ANTENNA POLARITY : VERTICAL										
Frequency (MHz)	Level (dBuV/m)	Over Limit (dB)	Limit Line (dBuV/m)	Read Level (dBuV)	Antenna Factor (dB)	Cable Loss (dB)	Preamp Factor (dB)	Ant Pos (cm)	Table Pos (deg)	Remark
2338.00	55.76	-18.24	74.00	56.00	31.72	3.21	35.17	100	0	Peak
2338.00	38.60	-15.40	54.00	38.84	31.72	3.21	35.17	100	0	Average

Test Mode :	Mode 3	Temperature :	26~27°C
Test Channel :	78	Relative Humidity :	40~43%
		Test Engineer :	Alex Wang

ANTENNA POLARITY : HORIZONTAL										
Frequency (MHz)	Level (dBuV/m)	Over Limit (dB)	Limit Line (dBuV/m)	Read Level (dBuV)	Antenna Factor (dB)	Cable Loss (dB)	Preamp Factor (dB)	Ant Pos (cm)	Table Pos (deg)	Remark
2483.50	70.63	-3.37	74.00	70.30	32.24	3.29	35.20	100	0	Peak
2483.50	36.96	-17.04	54.00	36.63	32.24	3.29	35.20	125	0	Average

ANTENNA POLARITY : VERTICAL										
Frequency (MHz)	Level (dBuV/m)	Over Limit (dB)	Limit Line (dBuV/m)	Read Level (dBuV)	Antenna Factor (dB)	Cable Loss (dB)	Preamp Factor (dB)	Ant Pos (cm)	Table Pos (deg)	Remark
2483.50	65.18	-8.82	74.00	64.85	32.24	3.29	35.20	100	0	Peak
2483.50	35.44	-18.56	54.00	35.11	32.24	3.29	35.20	119	0	Average

3.6.6 Test Result of Conducted Band Edges

Test Mode :	Mode 1 and 3	Temperature :	25~26°C
Test Channel :	00 and 78	Relative Humidity :	44~45%
		Test Engineer :	Rain Zhou

Low Band Edge Plot on Channel 00

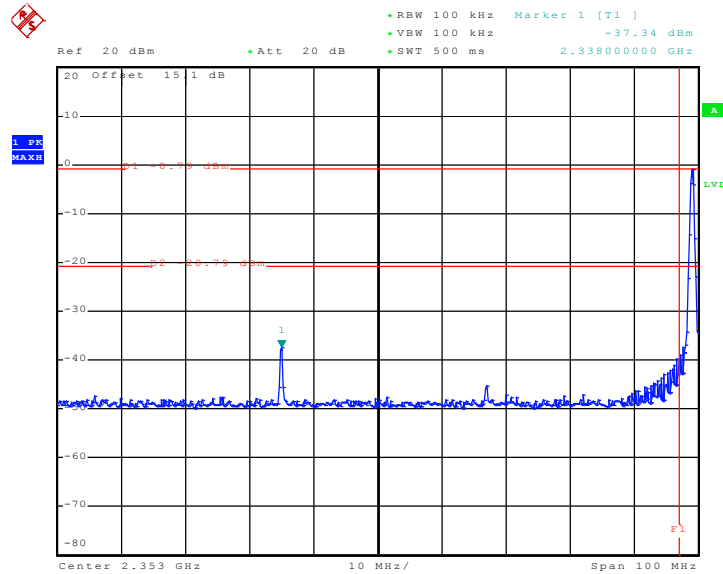

Date: 2.JUN.2009 15:45:55



High Band Edge Plot on Channel 78

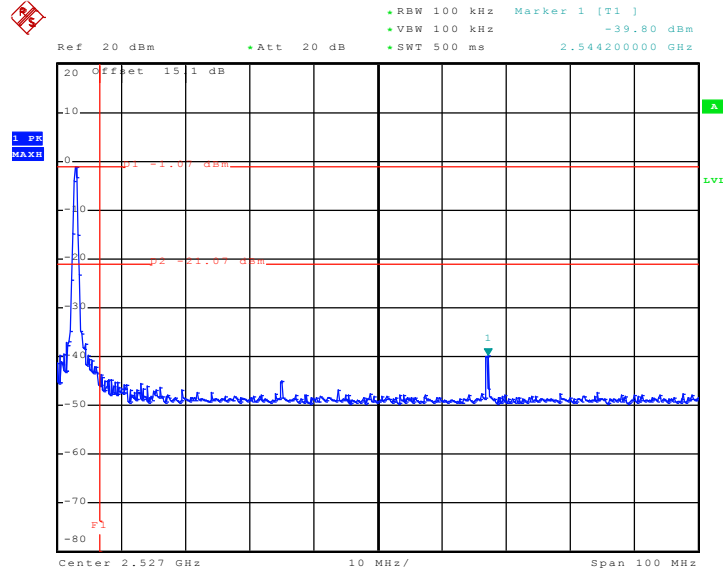

Date: 2..JUN.2009 15:48:13

3.8 AC Conducted Emission Measurement

3.8.1 Limit of AC Conducted Emission

For equipment that is designed to be connected to the public utility (AC) power line, the radio frequency voltage that is conducted back onto the AC power line on any frequency or frequencies within the band 150 kHz to 30 MHz shall not exceed the limits in the following table.

Frequency of emission (MHz)	Conducted limit (dBuV)	
	Quasi-peak	Average
0.15-0.5	66 to 56*	56 to 46*
0.5-5	56	46
5-30	60	50

*Decreases with the logarithm of the frequency.

3.8.2 Measuring Instruments

See list of measuring instruments of this test report.

3.8.3 Test Procedures

1. Please follow the guidelines in ANSI C63.4-2003.
2. The EUT was placed 0.4 meter from the conducting wall of the shielding room was kept at least 80 centimeters from any other grounded conducting surface.
3. Connect EUT to the power mains through a line impedance stabilization network (LISN).
4. All the support units are connecting to the other LISN.
5. The LISN provides 50 ohm coupling impedance for the measuring instrument.
6. The FCC states that a 50 ohm, 50 microhenry LISN should be used.
7. Both sides of AC line were checked for maximum conducted interference.
8. The frequency range from 150 kHz to 30 MHz was searched.
9. Set the test-receiver system to Peak Detect Function and specified bandwidth with Maximum Hold Mode.

3.8.4 Test Setup

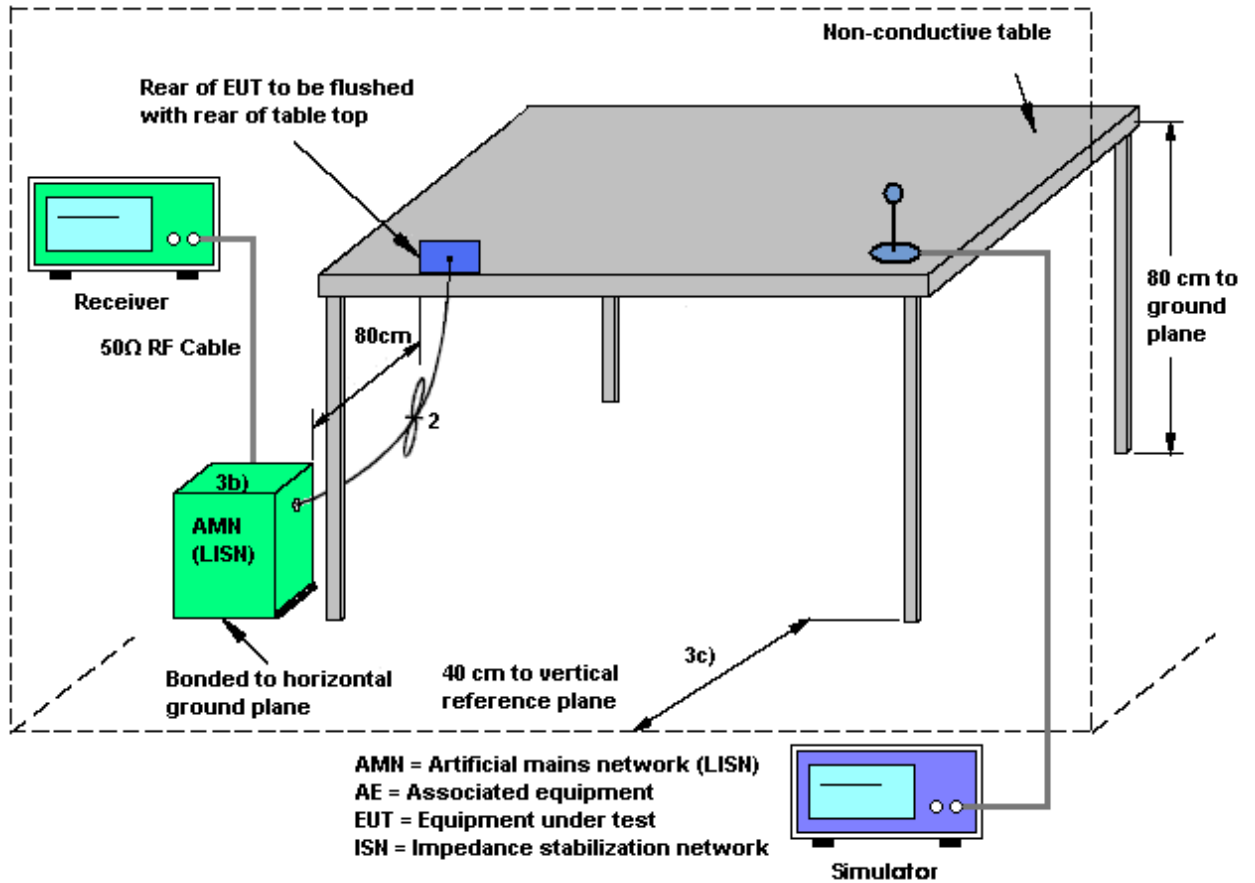



3.8.5 Test Result of AC Conducted Emission

Test Mode :	Mode 1	Temperature :	25~26°C
Test Engineer :	Rain Zhou	Relative Humidity :	44~45%
Test Voltage :	120Vac / 60Hz	Phase :	Line
Function Type :	GSM850 Idle + BT Link + Adapter		
Remark :	All emissions not reported here are more than 10 dB below the prescribed limit.		

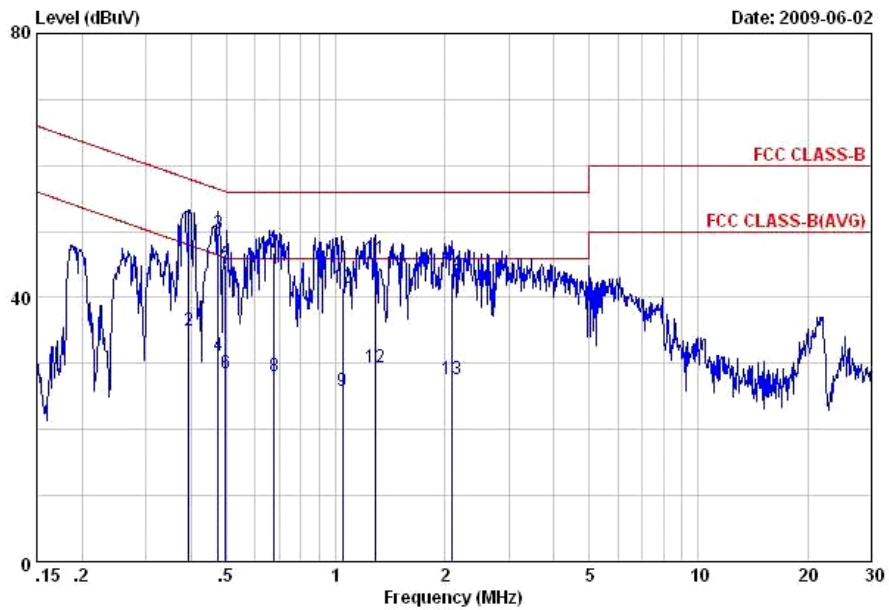

Site : C001-KS
 Condition: FCC CLASS-B LISN-071001 LINE

Memo : Mode 1

	Freq	Level	Over	Limit	Read	LISN	Cable	Remark
	MHz	dBuV	Limit	Line	Level	Factor	Loss	
			dB	dBuV	dBuV	dB	dB	
1	0.39	50.51	-7.49	58.00	40.40	-0.08	10.19	QP
2	0.39	35.01	-12.99	48.00	24.90	-0.08	10.19	Average
3	0.47	49.62	-6.83	56.45	39.50	-0.08	10.20	QP
4	0.47	31.12	-15.33	46.45	21.00	-0.08	10.20	Average
5	0.50	44.93	-11.12	56.05	34.80	-0.08	10.21	QP
6	0.50	28.63	-17.42	46.05	18.50	-0.08	10.21	Average
7	0.68	46.74	-9.26	56.00	36.60	-0.09	10.23	QP
8	0.68	28.04	-17.96	46.00	17.90	-0.09	10.23	Average
9	1.04	25.87	-20.13	46.00	15.70	-0.10	10.27	Average
10	1.04	41.37	-14.63	56.00	31.20	-0.10	10.27	QP
11	1.29	45.88	-10.12	56.00	35.69	-0.10	10.29	QP
12	1.29	29.38	-16.62	46.00	19.19	-0.10	10.29	Average
13	2.10	27.52	-18.48	46.00	17.30	-0.11	10.33	Average
14	2.10	43.62	-12.38	56.00	33.40	-0.11	10.33	QP



Test Mode :	Mode 1	Temperature :	25~26°C
Test Engineer :	Rain Zhou	Relative Humidity :	44~45%
Test Voltage :	120Vac / 60Hz	Phase :	Neutral
Function Type :	GSM850 Idle + BT Link + Adapter		
Remark :	All emissions not reported here are more than 10 dB below the prescribed limit.		

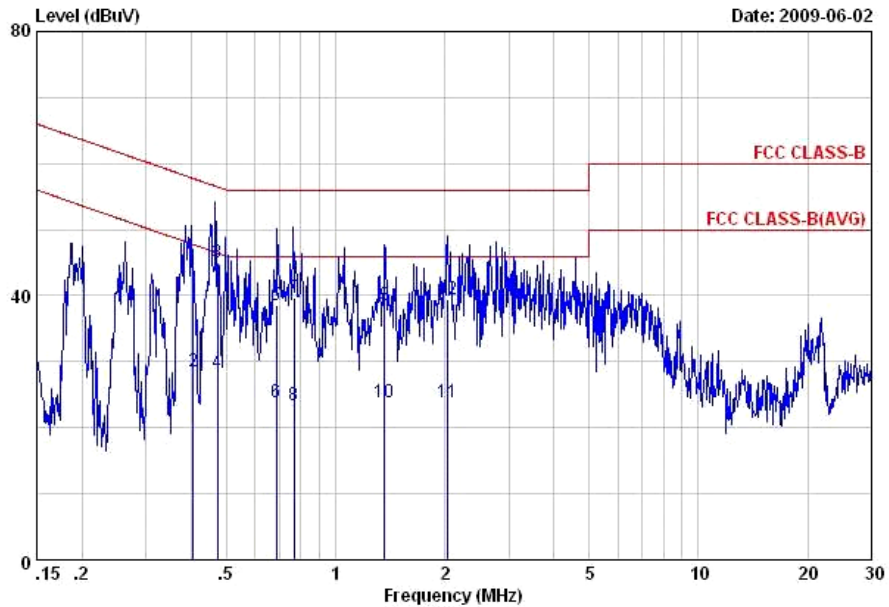

Site : C001-KS
 Condition: FCC CLASS-B LISN-071001 NEUTRAL

Memo : Mode 1

	Freq	Level	Over	Limit	Read	LISN	Cable	Remark
	MHz	dBuV	Limit	Line	Level	Factor	Loss	
			dB	dBuV	dBuV	dB	dB	
1	0.40	43.81	-13.95	57.76	33.70	-0.08	10.19	QP
2	0.40	28.51	-19.25	47.76	18.40	-0.08	10.19	Average
3	0.47	45.12	-11.36	56.48	35.00	-0.08	10.20	QP
4	0.47	28.32	-18.16	46.48	18.20	-0.08	10.20	Average
5	0.69	38.65	-17.35	56.00	28.50	-0.08	10.23	QP
6	0.69	23.95	-22.05	46.00	13.80	-0.08	10.23	Average
7	0.77	39.76	-16.24	56.00	29.60	-0.08	10.24	QP
8	0.77	23.46	-22.54	46.00	13.30	-0.08	10.24	Average
9	1.37	38.49	-17.51	56.00	28.30	-0.10	10.29	QP
10	1.37	23.89	-22.11	46.00	13.70	-0.10	10.29	Average
11	2.03	23.82	-22.18	46.00	13.60	-0.11	10.33	Average
12	2.03	39.52	-16.48	56.00	29.30	-0.11	10.33	QP

3.9 Radiated Emission Measurement

3.9.1 Limit of Radiated Emission

In any 100 kHz bandwidth outside the intentional radiator frequency band, all harmonics/spurious must be at least 20 dB below the highest emission level within the authorized band. In addition, radiated emissions which fall in the restricted bands must also comply with the FCC section 15.209 limits as below.

Frequency (MHz)	Field Strength (microvolts/meter)	Measurement Distance (meters)
0.009 – 0.490	2400/F(kHz)	300
0.490 – 1.705	24000/F(kHz)	30
1.705 – 30.0	30	30
30 – 88	100	3
88 – 216	150	3
216 - 960	200	3
Above 960	500	3

3.9.2 Measuring Instruments

See list of measuring instruments of this test report.

3.9.3 Test Procedures

1. The testing follows the guidelines in FCC Public Notice DA 00-705 Measurement Guidelines.
2. Use the following spectrum analyzer settings:
Span = wide enough to fully capture the emission being measured; RBW = 1 MHz for $f \geq 1$ GHz, 100 kHz for $f < 1$ GHz; VBW \geq RBW; Sweep = auto; Detector function = peak; Trace = max hold.
3. Follow the guidelines in ANSI C63.4-2003 with respect to maximizing the emission by rotating the EUT, measuring the emission for three EUT orthogonal planes, and adjusting the measurement antenna height and polarization. A pre-amp and a high pass filter are used for this test in order to get the good signal level.

3.9.4 Test Setup

For radiated emissions below 30MHz

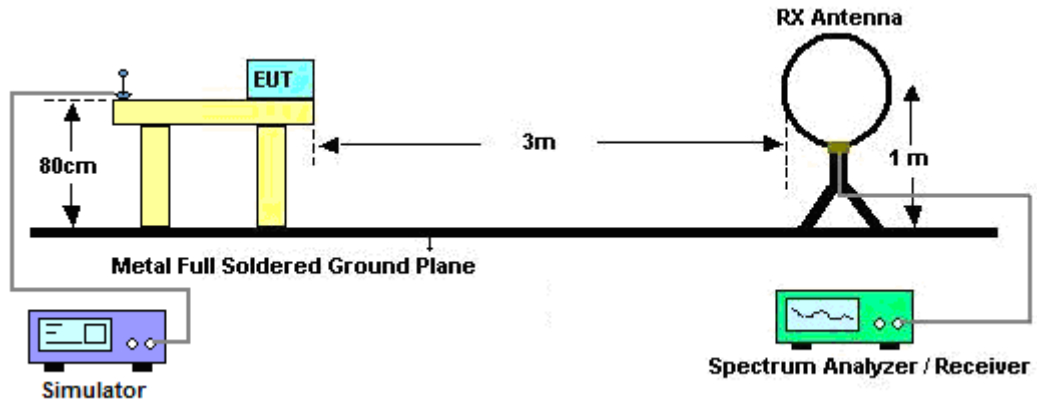

For radiated emissions above 30MHz

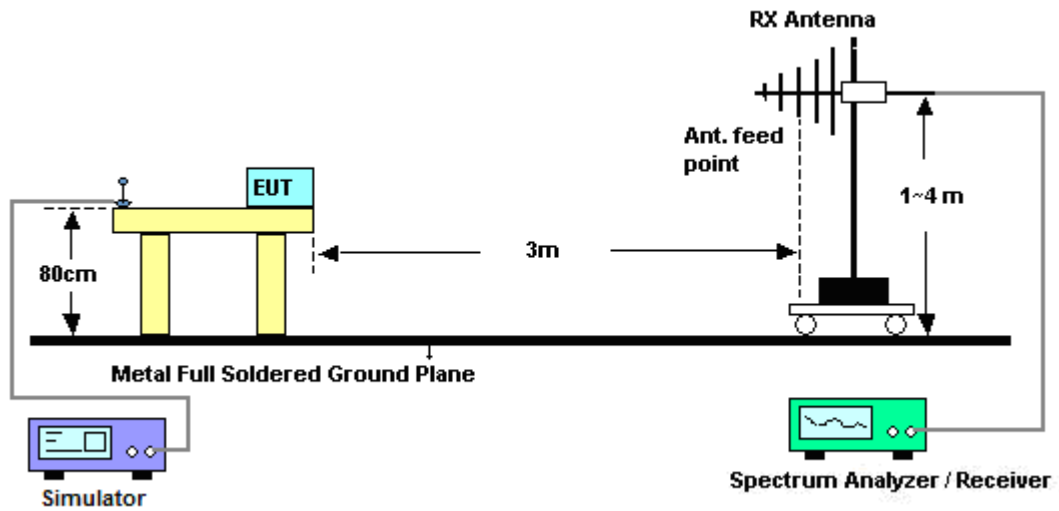



3.9.5 Test Results of Radiated Emissions (9kHz ~ 30MHz)

Test Engineer :	Alex Wang	Temperature :	26~27°C
		Relative Humidity :	40~43%

Frequency (MHz)	Level (dBuV)	Over Limit (dB)	Limit Line (dBuV)	Remark
-	-	-	-	See Note

Note:

The amplitude of spurious emissions that are attenuated by more than 20dB below the permissible value has no need to be reported.

Distance extrapolation factor = $40 \log(\text{specific distance} / \text{test distance})$ (dB);

Limit line = specific limits (dBuV) + distance extrapolation factor.



3.9.6 Test Result of Radiated Emission (30MHz ~ 10th Harmonic)

Test Mode :	Mode 1	Temperature :	26~27°C
Test Channel :	00	Relative Humidity :	40~43%
Test Engineer :	Alex Wang	Polarization :	Horizontal
Remark :	#9 and #10 are Fundamental Signals which can be ignored.		

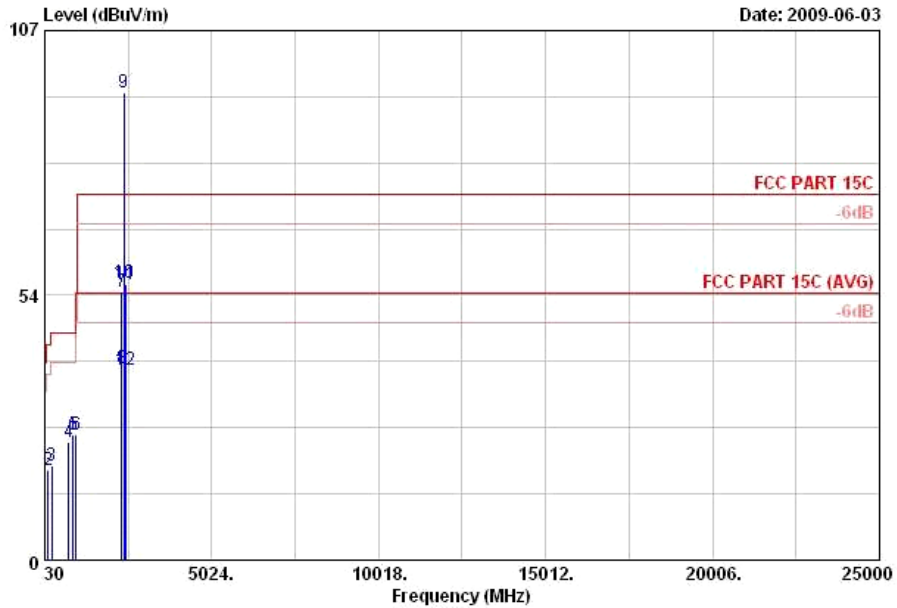

Site : 03CH01-KS
 Condition: FCC PART 15C 3m LF ANT-070906 HORIZONTAL

Mode : Mode 1
 : El Plane

	Freq	Level	Over Limit	Limit Line	ReadAntenna	Cable	Preamp	Ant	Table	Remark	
	MHz	dBuV/m	dB	dBuV/m	dBuV	dB/m	dB	dB	cm	deg	
1	30.27	19.21	-20.79	40.00	29.00	18.00	0.22	28.01	---	---	Peak
2	133.41	18.10	-25.40	43.50	34.04	11.55	0.54	28.03	---	---	Peak
3	240.33	19.00	-27.00	46.00	35.52	10.95	0.72	28.19	---	---	Peak
4	738.20	23.75	-22.25	46.00	30.18	20.11	1.31	27.85	---	---	Peak
5	874.00	25.36	-20.64	46.00	30.52	20.19	1.44	26.79	212	140	Peak
6	974.80	25.45	-28.55	54.00	29.62	21.18	1.52	26.87	---	---	Peak
7	2338.00	54.17	-19.83	74.00	54.41	31.72	3.21	35.17	100	0	Peak
8	2338.00	38.67	-15.33	54.00	38.91	31.72	3.21	35.17	100	360	Average
9 X	2402.00	94.49			94.49	31.93	3.25	35.18	100	0	Peak
10 X	2402.00	55.96			55.96	31.93	3.25	35.18	121	360	Average
11	2466.00	55.62	-18.38	74.00	55.34	32.19	3.28	35.19	100	0	Peak
12	2466.00	38.53	-15.47	54.00	38.25	32.19	3.28	35.19	197	151	Average



Test Mode :	Mode 1	Temperature :	26~27°C
Test Channel :	00	Relative Humidity :	40~43%
Test Engineer :	Alex Wang	Polarization :	Vertical
Remark :	#9 and #10 are Fundamental Signals which can be ignored.		

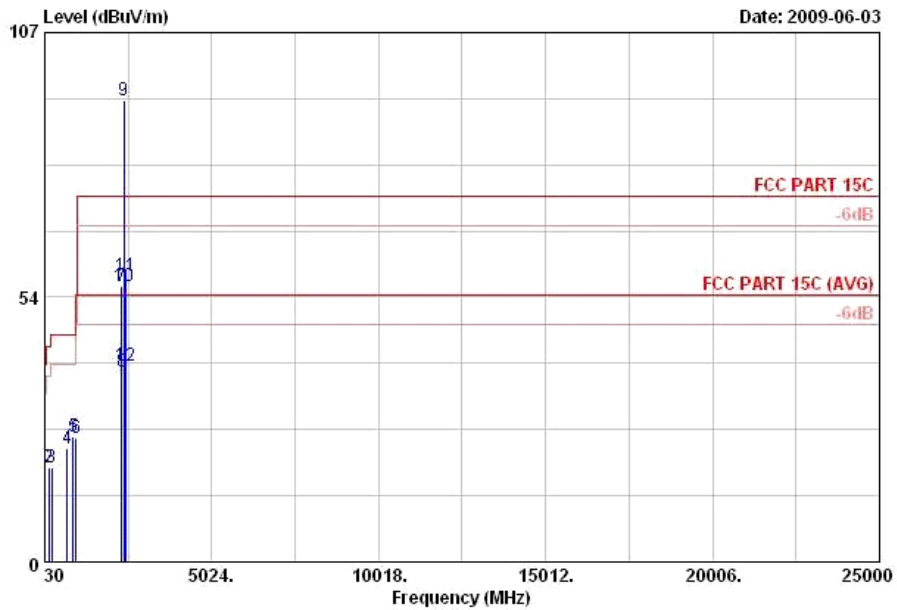

Site : 03CH01-KS
 Condition: FCC PART 15C 3m LF ANT-070906 VERTICAL

Mode : Mode 1
 : El Plane

	Freq	Level	Over	Limit	ReadAntenna	Cable	Preamp	Ant	Table	Remark
	MHz	dBuV/m	dB	dBuV/m	dBuV	dB/m	dB	dB	cm	deg
1	38.37	26.28	-13.72	40.00	40.63	13.40	0.28	28.03	100	223 Peak
2	147.99	19.00	-24.50	43.50	36.36	10.12	0.57	28.05	---	Peak
3	234.12	19.19	-26.81	46.00	36.40	10.25	0.71	28.17	---	Peak
4	706.70	22.82	-23.18	46.00	30.42	19.30	1.27	28.17	---	Peak
5	878.90	25.26	-20.74	46.00	30.45	20.14	1.45	26.78	---	Peak
6	959.40	25.09	-28.91	54.00	29.65	20.76	1.51	26.83	---	Peak
7	2338.00	55.76	-18.24	74.00	56.00	31.72	3.21	35.17	100	0 Peak
8	2338.00	38.60	-15.40	54.00	38.84	31.72	3.21	35.17	100	0 Average
9 X	2402.00	93.19			93.19	31.93	3.25	35.18	100	0 Peak
10 X	2402.00	55.83			55.83	31.93	3.25	35.18	121	0 Average
11	2466.00	57.89	-16.11	74.00	57.61	32.19	3.28	35.19	100	0 Peak
12	2466.00	39.75	-14.25	54.00	39.47	32.19	3.28	35.19	100	60 Average



Test Mode :	Mode 2	Temperature :	26~27°C
Test Channel :	39	Relative Humidity :	40~43%
Test Engineer :	Alex Wang	Polarization :	Horizontal
Remark :	#9 and #10 are Fundamental Signals which can be ignored.		

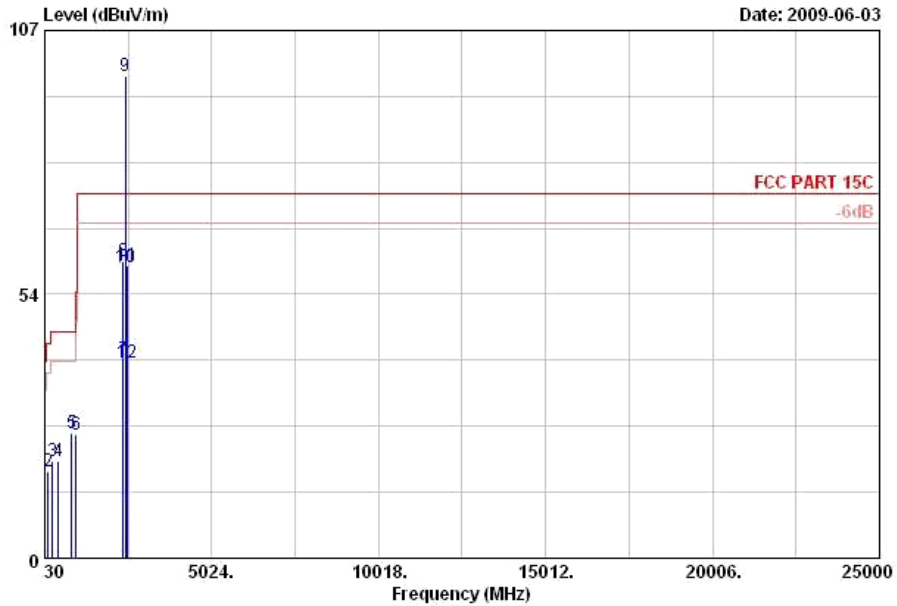

Site : 03CH01-KS
 Condition: FCC PART 15C 3m LF ANT-070906 HORIZONTAL

Mode : Mode 2
 : El Plane

	Freq	Level	Over Limit	Limit Line	ReadAntenna	Cable	Preamp	Ant	Table	Remark
	MHz	dBuV/m	dB	dBuV/m	dBuV	dB	dB	cm	deg	
1	30.00	19.69	-20.31	40.00	29.48	18.00	0.22	28.01	124	100 Peak
2	133.14	17.68	-25.82	43.50	33.62	11.55	0.54	28.03	---	--- Peak
3	250.59	19.71	-26.29	46.00	35.21	12.00	0.73	28.23	---	--- Peak
4	447.70	19.72	-26.28	46.00	30.83	16.30	0.99	28.40	---	--- Peak
5	840.40	25.40	-20.60	46.00	30.49	20.50	1.39	26.98	---	--- Peak
6	972.00	24.92	-29.08	54.00	29.08	21.18	1.52	26.86	---	--- Peak
7	2378.00	40.24	-13.76	54.00	40.32	31.87	3.23	35.18	108	0 Average
8	2378.00	60.22	-13.78	74.00	60.30	31.87	3.23	35.18	100	0 Peak
9 X	2442.00	97.73			97.52	32.13	3.27	35.19	100	0 Peak
10 X	2442.00	58.96			58.75	32.13	3.27	35.19	104	0 Average
11	2506.00	59.43	-14.57	74.00	59.03	32.29	3.31	35.20	100	0 Peak
12	2506.00	39.79	-14.21	54.00	39.39	32.29	3.31	35.20	100	0 Average



Test Mode :	Mode 2	Temperature :	26~27°C
Test Channel :	39	Relative Humidity :	40~43%
Test Engineer :	Alex Wang	Polarization :	Vertical
Remark :	#9 and #10 are Fundamental Signals which can be ignored.		

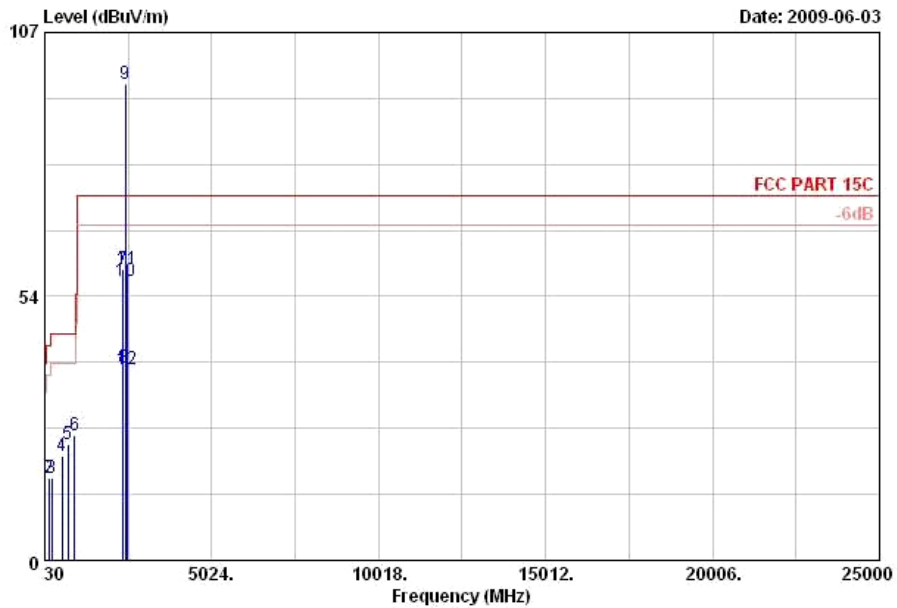

Site : 03CH01-KS
 Condition: FCC PART 15C 3m LF ANT-070906 VERTICAL

Mode : Mode 2
 : El Plane

	Freq	Level	Over	Limit	ReadAntenna	Cable	Preamp	Ant	Table	Remark
	MHz	dBuV/m	dB	dBuV/m	dBuV	dB/m	dB	dB	cm	deg
1	40.26	24.90	-15.10	40.00	40.34	12.30	0.29	28.03	241	142 Peak
2	146.10	16.66	-26.84	43.50	33.92	10.23	0.56	28.05	---	Peak
3	238.98	16.82	-29.18	46.00	33.56	10.72	0.72	28.18	---	Peak
4	538.00	21.14	-24.86	46.00	30.36	18.20	1.11	28.53	---	Peak
5	722.80	23.55	-22.45	46.00	30.62	19.67	1.29	28.03	---	Peak
6	924.40	25.27	-20.73	46.00	30.04	20.48	1.49	26.74	---	Peak
7	2378.00	58.91	-15.09	74.00	58.99	31.87	3.23	35.18	100	0 Peak
8	2378.00	39.02	-14.98	54.00	39.10	31.87	3.23	35.18	145	184 Average
9 X	2442.00	96.67			96.46	32.13	3.27	35.19	100	0 Peak
10 X	2442.00	56.58			56.37	32.13	3.27	35.19	120	6 Average
11	2506.00	59.02	-14.98	74.00	58.62	32.29	3.31	35.20	100	0 Peak
12	2506.00	38.84	-15.16	54.00	38.44	32.29	3.31	35.20	196	6 Average



Test Mode :	Mode 3	Temperature :	26~27°C
Test Channel :	78	Relative Humidity :	40~43%
Test Engineer :	Alex Wang	Polarization :	Horizontal
Remark :	#9 and #10 are Fundamental Signals which can be ignored.		

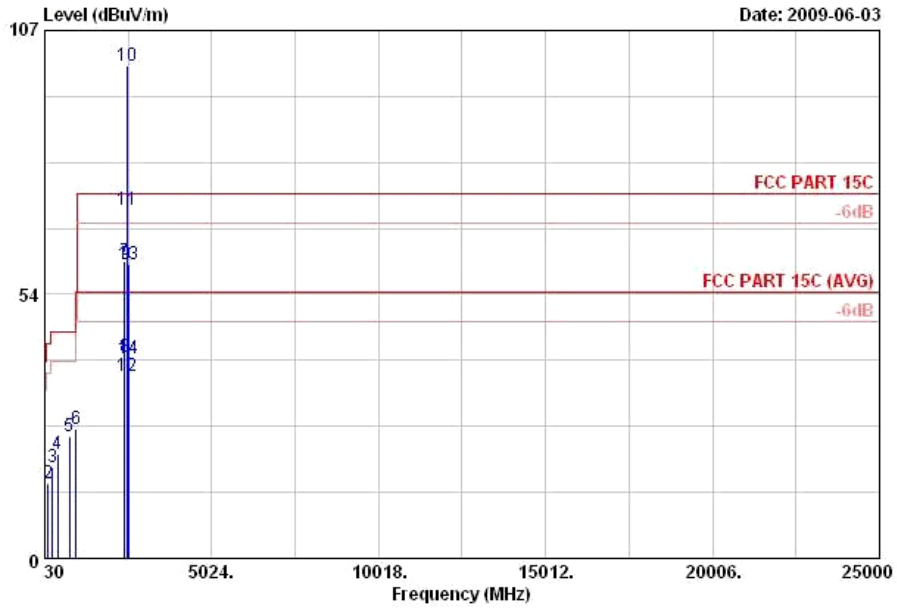

Site : 03CH01-KS
 Condition: FCC PART 15C 3m LF ANT-070906 HORIZONTAL

Mode : Mode 3
 : El Plane

	Freq	Level	Over	Limit	ReadAntenna	Cable	Preamp	Ant	Table	Remark
	MHz	dBuV/m	dB	dBuV/m	dBuV	dB/m	dB	dB	cm	deg
1	30.54	20.47	-19.53	40.00	30.26	18.00	0.22	28.01	100	246 Peak
2	125.85	15.27	-28.23	43.50	30.94	11.83	0.53	28.03	---	Peak
3	250.86	18.59	-27.41	46.00	34.09	12.00	0.73	28.23	---	Peak
4	416.20	21.19	-24.81	46.00	32.14	16.50	0.96	28.41	---	Peak
5	766.20	24.68	-21.32	46.00	31.06	19.75	1.33	27.46	---	Peak
6	969.90	26.19	-27.81	54.00	30.35	21.18	1.52	26.86	---	Peak
7	2416.00	60.29	-13.71	74.00	60.22	32.00	3.26	35.19	100	0 Peak
8	2416.00	40.77	-13.23	54.00	40.70	32.00	3.26	35.19	100	0 Average
9 X	2480.00	59.56			59.23	32.24	3.29	35.20	100	360 Average
10 X	2480.00	99.72			99.39	32.24	3.29	35.20	100	0 Peak
11 !	2483.50	70.63	-3.37	74.00	70.30	32.24	3.29	35.20	100	0 Peak
12	2483.50	36.96	-17.04	54.00	36.63	32.24	3.29	35.20	125	0 Average
13	2544.00	59.63	-14.37	74.00	59.26	32.27	3.32	35.22	100	0 Peak
14	2544.00	40.60	-13.40	54.00	40.23	32.27	3.32	35.22	100	334 Average



Test Mode :	Mode 3	Temperature :	26~27°C
Test Channel :	78	Relative Humidity :	40~43%
Test Engineer :	Alex Wang	Polarization :	Vertical
Remark :	#9 and #10 are Fundamental Signals which can be ignored.		

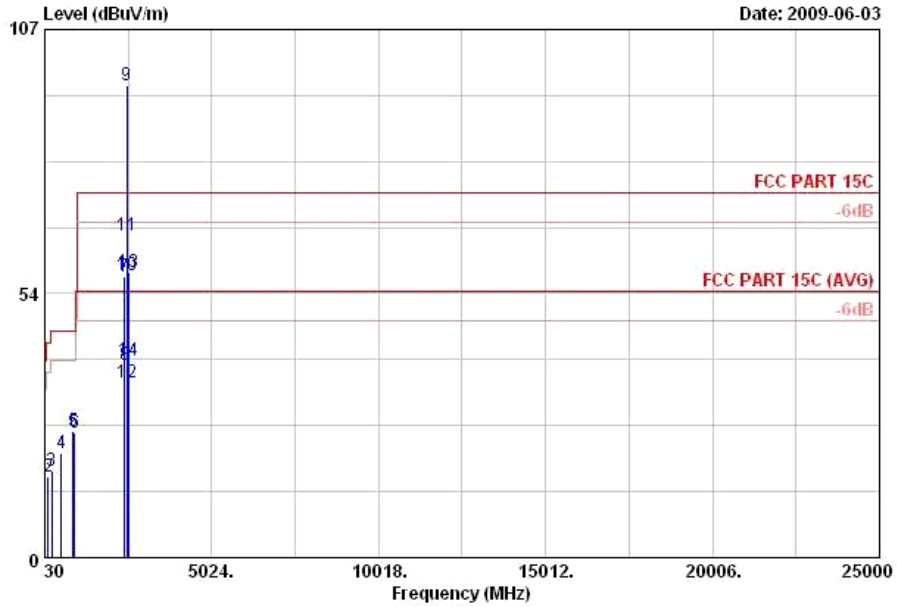

Site : 03CH01-KS
 Condition: FCC PART 15C 3m LF ANT-070906 VERTICAL

Mode : Mode 3
 : El Plane

	Freq	Level	Over	Limit	ReadAntenna	Cable	Preamp	Ant	Table	Remark
	MHz	dBuV/m	Limit	Line	Level	Loss	Factor	Pos	Pos	
			dB	dBuV/m	dBuV	dB	dB	cm	deg	
1	38.10	26.10	-13.90	40.00	40.45	13.40	0.28	28.03	224	Peak
2	132.06	16.30	-27.20	43.50	32.24	11.55	0.54	28.03	---	Peak
3	236.01	17.44	-28.56	46.00	34.43	10.48	0.71	28.18	---	Peak
4	526.80	21.12	-24.88	46.00	30.92	17.58	1.09	28.47	---	Peak
5	878.90	25.52	-20.48	46.00	30.71	20.14	1.45	26.78	---	Peak
6	923.00	25.31	-20.69	46.00	30.07	20.49	1.49	26.74	---	Peak
7	2416.00	57.04	-16.96	74.00	56.97	32.00	3.26	35.19	100	0 Peak
8	2416.00	39.01	-14.99	54.00	38.94	32.00	3.26	35.19	173	360 Average
9 X	2480.00	95.72			95.39	32.24	3.29	35.20	100	0 Peak
10 X	2480.00	57.36			57.03	32.24	3.29	35.20	123	360 Average
11	2483.50	65.18	-8.82	74.00	64.85	32.24	3.29	35.20	100	0 Peak
12	2483.50	35.44	-18.56	54.00	35.11	32.24	3.29	35.20	119	0 Average
13	2544.00	57.75	-16.25	74.00	57.38	32.27	3.32	35.22	100	0 Peak
14	2544.00	40.02	-13.98	54.00	39.65	32.27	3.32	35.22	126	0 Average



3.10 Antenna Requirements

3.10.1 Standard Applicable

If directional gain of transmitting antennas is greater than 6dBi, the power shall be reduced by the same level in dB comparing to gain minus 6dBi. The use of a permanently attached antenna or of an antenna that uses a unique coupling to the intentional radiator shall be considered sufficient to comply with the FCC rule.

3.10.2 Antenna Connected Construction

The antennas type used in this product is PCB Antenna without connector and it is considered to meet antenna requirement.

3.10.3 Antenna Gain

The antenna peak gain of EUT is less than 6 dBi. Therefore, it is not necessary to reduce maximum peak output power limit.

4 List of Measuring Equipment

Instrument	Manufacturer	Model No.	Serial No.	Characteristics	Calibration Date	Due Date	Remark
Spectrum Analyzer	R&S	FSP40	100319	9kHz~40GHz	Dec. 08, 2008	Dec. 07, 2009	Conducted (TH01-KS)
Power Meter	Agilent	E4416A	MY451015 55	N/A	Jun. 18, 2009	Jun. 17, 2011	Conducted (TH01-KS)
Power Sensor	Agilent	E9327A	MY444211 98	N/A	Jun. 12, 2009	Jun. 11, 2011	Conducted (TH01-KS)
Thermal Chamber	Ten Billion	TTC-B3S	TBN-9307 01	N/A	Dec. 15, 2008	Dec. 14, 2009	Conducted (TH01-KS)
EMI Receiver	R&S	ESCI	100534	9kHz~2.75GHz	Dec. 08, 2008	Dec. 07, 2009	Conduction (CO01-KS)
LISN	MessTec	AN3016	060103	9kHz~30MHz	Dec. 18, 2008	Dec. 17, 2009	Conduction (CO01-KS)
LISN	MessTec	AN3016	060105	9kHz~30MHz	Dec. 18, 2008	Dec. 17, 2009	Conduction (CO01-KS)
DC- LISN	EM Test	AN20200	060102	0.1MHz~108MHz z	Dec. 18, 2008	Dec. 17, 2009	Conduction (CO01-KS)
DC- LISN	EM Test	AN20200	060107	0.1MHz~108MHz z	Dec. 18, 2008	Dec. 17, 2009	Conduction (CO01-KS)
AC Power Source	APC	APC-1000W	N/A	N/A	N/A	N/A	Conduction (CO01-KS)
ISN	MessTec	AN3016	060103	9kHz – 30MHz	Dec. 18, 2008	Dec. 17, 2009	Conduction (CO01-KS)
System Simulator	R&S	CMU200	837587/06 6	Full-Band/BT	Jan. 08, 2009	Jan. 07, 2011	Conduction (CO01-KS)
Spectrum Analyzer	R&S	ESCI	100534	9kHz – 2.75GHz	Dec. 08, 2008	Dec. 07, 2009	Radiation (03CH01-KS)
Spectrum Analyzer	R&S	FSP40	100319	9kHz~40GHz	Dec. 08, 2008	Dec. 07, 2009	Radiation (03CH01-KS)
Bilog Antenna	SCHAFFNER	CBL6112D	23182	25MHz~2GHz	Dec. 17, 2008	Dec. 16, 2009	Radiation (03CH01-KS)
Double Ridge Horn Antenna	EMCO	3117	75959	1GHz~18GHz	Dec. 17, 2008	Dec. 16, 2009	Radiation (03CH01-KS)
Amplifier	Wireless	FPA6592G	600006	30MHz~2GHz	Dec. 17, 2008	Dec. 16, 2009	Radiation (03CH01-KS)
Amplifier	Agilent	8449B	3008A023 70	1GHz~26.5GHz	Dec. 17, 2008	Dec. 16, 2009	Radiation (03CH01-KS)
Signal Generator	R&S	SMR40	100455	10MHz~40GHz	Aug. 29, 2007	Aug. 28, 2009	Radiation (03CH01-KS)
BT Base Station	ANRITSU	MT8852B	N/A	BT EDR	N/A	N/A	Radiation (03CH01-KS)

5 Uncertainty of Evaluation

Uncertainty of Conducted Emission Measurement (150kHz ~ 30MHz)

Contribution	Uncertainty of x_i		$u(x_i)$
	dB	Probability Distribution	
Receiver reading	0.10	Normal(k=2)	0.05
Cable loss	0.10	Normal(k=2)	0.05
AMN insertion loss	2.50	Rectangular	0.63
Receiver Spec	1.50	Rectangular	0.43
Site imperfection	1.39	Rectangular	0.80
Mismatch	+0.34/-0.35	U-shape	0.24
Combined standard uncertainty Uc(y)	1.13		
Measuring uncertainty for a level of confidence of 95% U=2Uc(y)	2.26		

Uncertainty of Radiated Emission Measurement (30MHz ~ 1000MHz)

Contribution	Uncertainty of x_i		$u(x_i)$
	dB	Probability Distribution	
Receiver reading	0.41	Normal(k=2)	0.21
Antenna factor calibration	0.83	Normal(k=2)	0.42
Cable loss calibration	0.25	Normal(k=2)	0.13
Pre Amplifier Gain calibration	0.27	Normal(k=2)	0.14
RCV/SPA specification	2.50	Rectangular	0.72
Antenna Factor Interpolation for Frequency	1.00	Rectangular	0.29
Site imperfection	1.43	Rectangular	0.83
Mismatch	+0.39/-0.41	U-shaped	0.28
Combined standard uncertainty Uc(y)	1.27		
Measuring uncertainty for a level of confidence of 95% U=2Uc(y)	2.54		

Uncertainty of Radiated Emission Measurement (1GHz ~ 40GHz)

Contribution	Uncertainty of x_i		$u(x_i)$	C_i	$C_i * u(x_i)$
	dB	Probability Distribution			
Receiver reading	±0.10	Normal(k=1)	0.10	1	0.10
Antenna factor calibration	±1.70	Normal(k=2)	0.85	1	0.85
Cable loss calibration	±0.50	Normal(k=2)	0.25	1	0.25
Receiver Correction	±2.00	Rectangular	1.15	1	1.15
Antenna Factor Directional	±1.50	Rectangular	0.87	1	0.87
Site imperfection	±2.80	Triangular	1.14	1	1.14
Mismatch Receiver VSWR $\Gamma_1 = 0.197$ Antenna VSWR $\Gamma_2 = 0.194$ Uncertainty = $20 \log(1 - \Gamma_1 * \Gamma_2)$	+0.34/-0.35	U-shaped	0.244	1	0.244
Combined standard uncertainty Uc(y)	2.36				
Measuring uncertainty for a level of confidence of 95% U=2Uc(y)	4.72				

6 Certification of TAF Accreditation



Certificate No. : L1190-090417

財團法人全國認證基金會
Taiwan Accreditation Foundation

Certificate of Accreditation

This is to certify that

Sporton International Inc.
EMC & Wireless Communications Laboratory
No.52, Hwa Ya 1st Rd., Hwa Ya Technology Park, Kwei-Shan Hsiang, Tao Yuan Hsien,
Taiwan, R.O.C.

is accredited in respect of laboratory

Accreditation Criteria	: ISO/IEC 17025:2005
Accreditation Number	: 1190
Originally Accredited	: December 15, 2003
Effective Period	: January 10, 2007 to January 09, 2010
Accredited Scope	: Testing Field, see described in the Appendix
Specific Accreditation Program	: Accreditation Program for Designated Testing Laboratory for Commodities Inspection Accreditation Program for Telecommunication Equipment Testing Laboratory Accreditation Program for BSMI Mutual Recognition Arrangement with Foreign Authorities

Jay-San Chen
President, Taiwan Accreditation Foundation
Date : April 17, 2009

P1, total 20 pages

The Appendix forms an integral part of this Certificate, which shall be invalid when use without the Appendix



Appendix A. Photographs of EUT

Please refer to Sporton report number EP952506 as below.