



a module solution provider

WS2119-A0

WS2119-F0

**Ultralow Power 915MHz and BLE Wireless MCU Module
STM S2-LP with PA & BlueNRG-1 Solution**

Datasheet

Draft 0.7

| Prepared By | Reviewed By | Approved By |
|-------------|-------------|-------------|
| | | |

Index

| | |
|---|-----------|
| 1. OVERVIEW | 3 |
| 1.1. GENERAL FEATURES | 3 |
| 1.2. MODELS FUNCTIONAL BLOCKS | 3 |
| 2. FUNCTIONAL FEATURES | 4 |
| 2.1. MODULE BLOCK DIAGRAM | 4 |
| 2.2. BLOCK FUNCTIONAL FEATURE | 5 |
| <i>BlueNRG-1 : Bluetooth low energy wireless SOC</i> | 5 |
| <i>S2-LP Sub-1Ghz transceiver</i> | 5 |
| <i>RFX1010 : Sub-1GHz RF Front-End Module</i> | 6 |
| <i>STSAFE-A1SX : Secure Element (WS2119-F0 only)</i> | 6 |
| 3. MODULE OUTLINE | 7 |
| 3.1. SIGNAL LAYOUT (TOP VIEW) | 7 |
| 3.2. PIN DESCRIPTION | 8 |
| 4. MODULE SPECIFICATIONS | 10 |
| 4.1. ABSOLUTE MAXIMUM RATINGS | 10 |
| 4.2. ESD RATINGS | 10 |
| 4.3. RECOMMENDED OPERATING CONDITIONS | 10 |
| 4.4. POWER CONSUMPTION SUMMARY | 11 |
| 4.5. 2.4GHZ GFSK (BLUETOOTH LOW ENERGY) RF CHARACTERISTICS | 12 |
| 4.6. SUB-1GHZ RF CHARACTERISTICS | 12 |
| 4.7. INTERNAL 16-MHZ CRYSTAL OSCILLATOR (FOR BLUENRG-1) | 13 |
| 4.8. INTERNAL 32.768-KHZ CRYSTAL OSCILLATOR (FOR BLUENRG-1) | 13 |
| 4.9. INTERNAL 50MHZ CRYSTAL OSCILLATOR (FOR S2-LP) | 14 |
| 4.10. BLUENRG-1 DIGITAL I/O SPECIFICATIONS | 14 |
| 4.11. S2-LP DIGITAL INTERFACE SPECIFICATION | 15 |
| 4.12. RFX1010 DIGITAL INTERFACE SPECIFICATION | 15 |
| 4.13. RFX1010 GAIN VS. POUT | 16 |
| 4.14. RFX1010 CW CURRENT VS. POUT | 16 |
| 4.15. RFX1010 VDET VS. POUT | 17 |
| 4.16. MORE CHARACTERISTICS | 17 |
| 5. DESIGN RECOMMENDATIONS | 18 |
| 5.1. GPIO USAGE OF BLUENRG-1 | 18 |

| | |
|---|-----------|
| 5.2. POWER VOLTAGE RANGE | 18 |
| 5.3. DEBUG PORT | 19 |
| 5.4. DEBUGGING TIPS..... | 19 |
| 5.5. PRE-PROGRAMMED BOOTLOADER | 19 |
| 5.6. ANTENNA SELECTION GUIDE..... | 20 |
| 5.7. REFERENCE SCHEMATIC | 21 |
| 5.8. MODULE LAYOUT RECOMMENDATIONS | 21 |
| 6. PACKAGE INFORMATION | 22 |
| 6.1. MODULE MECHANICAL OUTLINE | 22 |
| 6.2. PACKAGE MARKING | 24 |
| 7. SMT AND BAKING RECOMMENDATION | 25 |
| 7.1. BAKING RECOMMENDATION | 25 |
| 7.2. SMT RECOMMENDATION | 25 |
| 8. REGULATORY INFORMATION | 27 |
| 8.1. UNITED STATES | 27 |
| 8.2. TAIWAN | 29 |
| 9. HISTORY CHANGE | 30 |

1. OVERVIEW

The WS2119-A0 series is a sub-1GHz with PA and Bluetooth® low energy ultralow power wireless MCU module. This module is built-in STM S2-LP and BlueNRG-1 chip.

The module is a cost-effective, high performance, ultra-low power, sub-1GHz and Bluetooth® low energy RF devices. Very low active RF and MCU current and low-power mode current consumption provide excellent battery lifetime and allow for operation on small coin cell batteries and in energy-harvesting applications.

1.1. General Features

- STM BlueNRG-1, S2-LP, sub-1GHz PA, 16MHz, 50MHz & 32.768KHz crystals, DC2DC, and U.FL connector on a single module.
- Stamp-hole 38pins package.
- Dimension 22mm(L) x 24mm(W) x 2.8mm(H)
- High performance, ultra-low power Cortex-M0 32-bit Microcontroller
- Programmable 160 KB Flash
- 24 KB RAM with retention (two 12 KB banks)
- Up to +8dBm BLE RF output power, up to +27dBm sub-1GHz RF output power ⁽¹⁾
- Excellent performance of receiver sensitivity. Up to -88dBm (BLE) and -130dBm (Sub-1GHz).
- Low Power and Wide I/O Voltage Range: 1.8 to 3.6V
 - Internal DC-DC converter built-in
- Operating temperature range: -40 °C to +85 °C

(1) In order to comply with FCC, NCC, Sigfox limits, the maximum RF output power must be reduced. See the 4. MODULE SPECIFICATIONS for details.

1.2. Models Functional Blocks

| Model | BLE & Sub-1GHz | Secure Element |
|-----------|----------------|----------------|
| WS2119-A0 | V | - |
| WS2119-F0 | V | V |

2. FUNCTIONAL FEATURES

2.1. Module Block Diagram

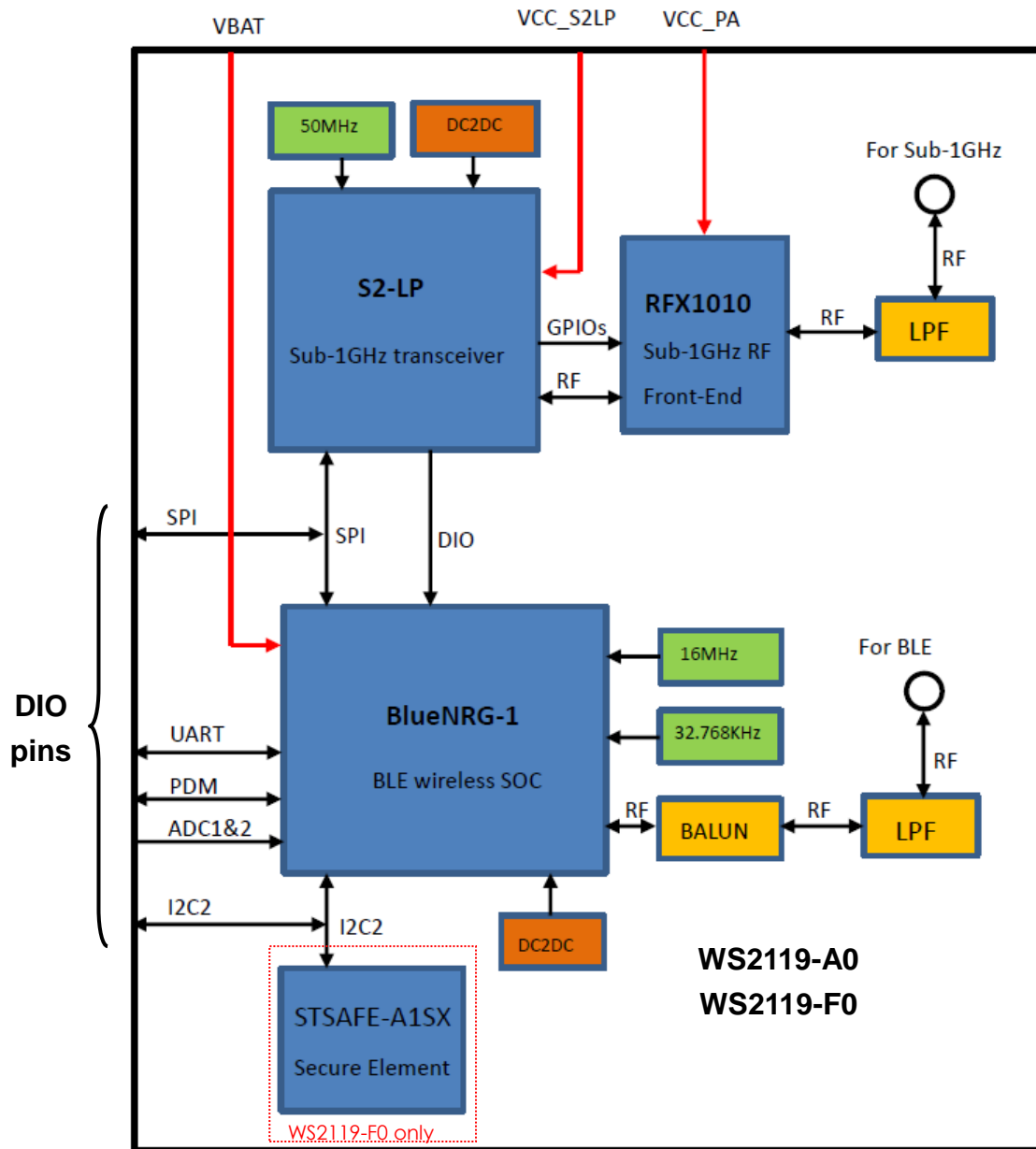

2.2. Block Functional Feature

BlueNRG-1 : Bluetooth low energy wireless SOC

- Bluetooth specification compliant master, slave and multiple roles simultaneously, single-mode Bluetooth low energy SOC
- Integrated linear regulator and DC-DC step-down converter
- High performance, ultra-low power Cortex-M0 32-bit based architecture core
- Programmable 160 KB Flash
- 24 KB RAM with retention (two 12 KB banks)
- 1 x UART interface
- 1 x SPI interface
- 1 x I²C interface
- 15 GPIO
- 2 x multifunction timer
- 10-bit ADC
- Watchdog & RTC
- DMA controller
- PDM stream processor
- 16 MHz crystal oscillator built-in.
- 32 kHz crystal oscillator built-in.
- Battery voltage monitor and temperature sensor
- Up to +8 dBm available output power (at antenna connector)
- Excellent RF link budget (up to 96 dB)
- BALF-NRG-01D3 BALUN built-in.
- Accurate RSSI to allow power control

S2-LP Sub-1Ghz transceiver

- Narrow band ultra-low power Sub-1GHz transceiver tuned for 860-943 MHz frequency bands.
- Suitable for SigFox applications
- Modulation schemes: 2-FSK, 2-GFSK, 4-FSK, 4-GFSK, OOK, and ASK
- Air data rate from 0.3 to 500 kbps
- Programmable RF output power up to +27 dBm (with RFX1010 RF front-end chip)

- Excellent performance of receiver sensitivity: down to -130 dBm
- Programmable RX digital filter
- Programmable channel spacing
- Low duty cycle RX/TX operation mode
- Integrated linear regulator and DC-DC step-down converter

RFX1010 : Sub-1GHz RF Front-End Module

- Integrated PA
- Integrated LNA with programmable bypass

STSAFE-A1SX : Secure Element (WS2119-F0 only)

- Data integrity over the Sigfox network:
 - Signature of payloads before uplink
 - Signature of payloads before uplink
- Optional data confidentiality over the Sigfox network:
 - Encryption of payloads before uplink
 - Decryption of downlink payloads
- Advanced symmetric cryptography : AES-128

3. MODULE OUTLINE

3.1. Signal Layout (Top View)



3.2. Pin Description

Table 3-1. Pin Description

| Pin No. | Pin Name | Type | Description |
|---------|--------------------------|---------------|---|
| 1 | GND | GND | GND |
| 2 | RESETN | Digital Input | System reset |
| 3 | DIO13 | Digital I/O | General purpose digital I/O of BlueNRG-1 Connected internally to GPIO3 of S2-LP for interrupt. |
| 4 | DIO12 | Digital I/O | General purpose digital I/O of BlueNRG-1 |
| 5 | TEST | Digital Input | Test pin put to GND |
| 6 | DIO11 | Digital I/O | General purpose digital I/O of BlueNRG-1 |
| 7 | DIO10 | Digital I/O | General purpose digital I/O of BlueNRG-1 |
| 8 | DIO9 | Digital I/O | General purpose digital I/O of BlueNRG-1 |
| 9 | DIO8 | Digital I/O | General purpose digital I/O of BlueNRG-1 |
| 10 | GND | GND | GND |
| 11 | VBAT | POWER | Power for BlueNRG-1 |
| 12 | GND | GND | GND |
| 13 | DIO7/BOOT ⁽¹⁾ | Digital I/O | Bootloader pin/ General purpose digital I/O of BlueNRG-1 |
| 14 | DIO6 | Digital I/O | General purpose digital I/O of BlueNRG-1 Connected internally to RESET pin of STSAFE-A1SX |
| 15 | DIO5 | Digital I/O | General purpose digital I/O of BlueNRG-1 Connected internally to SDA pin of STSAFE-A1SX |
| 16 | DIO4 | Digital I/O | General purpose digital I/O of BlueNRG-1 Connected internally to SCL pin of STSAFE-A1SX |
| 17 | DIO3 | Digital I/O | General purpose digital I/O of BlueNRG-1 / SPI master input pin connected internally to SDO pin of S2-LP |
| 18 | DIO2 | Digital I/O | General purpose digital I/O of BlueNRG-1 / SPI master output pin connected internally to SDI pin of S2-LP |
| 19 | DIO1 | Digital I/O | General purpose digital I/O of BlueNRG-1 / SPI master CS pin connected internally to CS pin of S2-LP Built-in pull-up 10K ohm resistor. |
| 20 | DIO0 | Digital I/O | General purpose digital I/O of BlueNRG-1 / SPI master CLK pin connected internally to SCLK pin of S2-LP |

| | | | |
|------|----------|---------------|--|
| 21 | DIO14 | Digital I/O | General purpose digital I/O of BlueNRG-1 / Connected internally to SDN pin of S2-LP Built-in pull-down 10K ohm resistor. |
| 22 | ANATEST1 | Analog Output | Analog output |
| 23 | ADC1 | Analog Input | ADC input1 |
| 24 | GND | GND | GND |
| 25 | ADC2 | Analog Input | ADC input2 |
| 26 | GND | GND | GND |
| 27 | VCC_S2LP | POWER | Power for S2-LP |
| 28 | GND | GND | GND |
| 29 | GPIO3 | Digital I/O | General purpose I/O of S2-LP. Connected internally to DIO13 pin of BlueNRG-1 for interrupt. |
| 30 | GPIO2 | Digital I/O | General purpose I/O of S2-LP. Connected internally to TXEN pin of RFX1010. Built-in pull-down 10K ohm resistor. |
| 31 | GPIO1 | Digital I/O | General purpose I/O of S2-LP. Connected internally to MODE pin of RFX1010. |
| 32 | GPIO0 | Digital I/O | General purpose I/O of S2-LP. Connected internally to RXEN pin of RFX1010. Built-in pull-down 10K ohm resistor. |
| 33 | PA_DET | Analog Output | Analog Voltage Proportional to the PA Power Output |
| 34 | VCC_PA1 | POWER | Power for RFX1010 |
| 35 | VCC_PA2 | POWER | Power for RFX1010 |
| 36 | GND | GND | GND |
| ANT1 | ANT1 | RF I/O | 2.4 GHz BLE antenna connector |
| ANT2 | ANT2 | RF I/O | Sub-1GHz antenna connector |

- (1) The pin DIO7/BOOT is monitored by bootloader after power up or hardware Reset and it should be low to prevent unwanted bootloader activation.

4. MODULE SPECIFICATIONS

4.1. Absolute Maximum Ratings

over operating free-air temperature range (unless otherwise noted)

| Pin | Parameter | MIN | MAX | Unit |
|---|---|------|------|------|
| 11, 27 | Power for BlueNRG-1 and S2-LP | -0.3 | +3.9 | V |
| 34, 35 | Power for RFX1010 | 0 | +4.2 | V |
| 3, 4, 5, 6, 7, 8, 9, 13, 14, 15, 16, 17, 18, 19, 20, 21, 29, | DC voltage on digital input/output pins | -0.3 | +3.9 | V |
| 22, 23, 25, | DC voltage on analog pins | -0.3 | +3.9 | V |
| 30, 31, 32 | DC voltage on digital control pins of PA. | 0 | +3.6 | V |
| ANT1 | Input RF level | | +11 | dBm |
| ANT2 | Input RF level | | +5 | dBm |
| | Storage temperature range | -40 | +85 | °C |

4.2. ESD Ratings

| Parameter | | | Value | Unit |
|-------------------------------------|----------|----------------|-------|------|
| Electrostatic discharge performance | VESD+HBM | BlueNRG-1 pins | ±2000 | V |
| | VESD+HBM | S2-LP pins | ±500 | V |
| | VESD+HBM | RF pins | ±500 | V |

4.3. Recommended Operating Conditions

| Parameter | Conditions | MIN | MAX | Unit |
|--|---------------|------|------|------|
| Ambient temperature range | | -40 | 85 | °C |
| V _{BAT} | For BlueNRG-1 | +1.7 | +3.6 | V |
| V _{CC_S2LP} | For S2-LP | +1.8 | +3.6 | V |
| V _{CC_PA1} , V _{CC_PA2} ⁽¹⁾ | For RFX1010 | +2.7 | +3.6 | V |

(1) The V_{CC_PA1}, V_{CC_PA2} are limited to +3.3V in Sigfox application

4.4. Power Consumption Summary

Ta = 25°C, VBAT=3.0 V, VCC_S2LP=3.0 V, VCC_PA = 3.3 V with internal DC-DC converter, unless otherwise noted.

| Parameter | | Test Conditions | Min | Typ | Max | Units | |
|------------------|--|--|------|------|------|-------|----|
| I _{BAT} | BlueNRG-1 Supply current | Reset | | 5 | | nA | |
| | | Standby | | 500 | | nA | |
| | | Sleep mode: 32 kHz XO ON (24 KB retention RAM) | | 0.9 | | μA | |
| | | Sleep mode: 32 kHz RO ON (24 KB retention RAM) | | 2.1 | | μA | |
| | | Active mode: CPU, Flash and RAM on | | 1.9 | | mA | |
| | | RX | | 7.7 | | mA | |
| | | BLE TX +8 dBm | | 15.1 | | mA | |
| | | BLE TX +4 dBm | | 10.9 | | mA | |
| | | BLE TX +2 dBm | | 9 | | mA | |
| | | BLE TX -2 dBm | | 8.3 | | mA | |
| | | BLE TX -5 dBm | | 7.7 | | mA | |
| | | BLE TX -8 dBm | | 7.1 | | mA | |
| | | BLE TX -11 dBm | | 6.8 | | mA | |
| | | BLE TX -14 dBm | | 6.6 | | mA | |
| | Peripheral Current Consumption (Adds to core current for each peripheral unit activated) | | | | | | |
| | BlueNRG-1 Peripheral current | GPIO | | | 11.6 | | μA |
| | | Flash controller | | | 6.3 | | μA |
| | | System controller | | | 0.2 | | μA |
| | | UART | | | 82.3 | | μA |
| | | SPI | | | 46.5 | | μA |
| | | Watchdog | | | 3.6 | | μA |
| | | ADC | | | 6.3 | | μA |
| | | I2C1 | | | 95.9 | | μA |
| | | MFT1 | | | 5.4 | | μA |
| MFT2 | | | | 6.2 | | μA | |
| RTC | | | | 7.5 | | μA | |
| DMA | | | | 16.3 | | μA | |
| RNG | | | | 21.7 | | μA | |
| PKA | | | 23.7 | | μA | | |

| | | | | | | |
|---------------------------|---------------------------|------------------------|--|------|--|----|
| I _{VCC_} S2LP | S2_LP Supply current | Shutdown | | 2.5 | | nA |
| | | Standby | | 350 | | nA |
| | | Sleep | | 600 | | nA |
| | | Sleep (FIFOs retained) | | 0.9 | | μA |
| | | Ready | | 350 | | μA |
| | | RX @ sensitivity level | | 8 | | mA |
| | | TX CW @ 14 dBm | | 20.6 | | mA |
| | | TX CW @ 10 dBm | | 11.7 | | mA |
| I _{VCC_} PA | RFX1010 Supply current | Shutdown Current | | 1 | | μA |
| | | TX CW @ 24 dBm | | 260 | | mA |
| | | TX CW @ 27 dBm | | 450 | | mA |
| | | RX, High Gain Mode | | 16 | | mA |
| | | RX, Low Gain Mode | | 10 | | mA |

4.5. 2.4GHz GFSK (Bluetooth Low Energy) RF Characteristics

RF performance is specified in a single ended 50 ohm reference plane at the U.FL connector with Ta = 25°C, VBAT = 3.0 V, f_{RF} = 2440 MHz, unless otherwise noted. Please see the more detail data in the STM's BlueNRG-1 datasheet.

| Parameter | Test Conditions | Min | Typ | Max | Units |
|-------------------------------------|------------------------|------|-----|--------|-------|
| Frequency range | | 2400 | - | 2483.5 | MHz |
| Channel spacing | | - | 2 | - | MHz |
| Channel center frequency | | 2402 | | 2480 | MHz |
| Receiver sensitivity | BER = 10 ⁻³ | | -87 | | dBm |
| Receiver saturation | BER = 10 ⁻³ | | 11 | | dBm |
| Maximum Output Power ⁽¹⁾ | At U.FL connector | | +8 | | dBm |
| Minimum Output Power | At U.FL connector | | -15 | | dBm |

(1) The maximum output power in FCC and NCC certification report is 8.66 dBm

4.6. Sub-1GHz RF Characteristics

RF performance is specified in a single ended 50 ohm reference plane at the U.FL connector with Ta = 25°C, VCC_S2LP = 3.3 V, VCC_PA=3.3V, unless otherwise noted. Please see the more detail data in the STM's S2_LP and Skyworks's RFX1010 datasheet.

| Parameter | Test Conditions | Min | Typ | Max | Units |
|-----------------------------------|-----------------|-----|-----|-----|-------|
| Frequency range ⁽¹⁾⁽²⁾ | | 902 | - | 928 | MHz |
| Data rate – 2-(G)FSK | | 0.3 | - | 250 | kbps |

| | | | | | |
|---|--|------|------|-----|------|
| Data rate – 4-(G)FSK | | 0.6 | - | 500 | kbps |
| Data rate – OOK/ASK | | 0.3 | - | 125 | kbps |
| Frequency deviation FDEV | | 0.15 | - | 500 | kHz |
| Sensitivity @ 920MHz, Low Gain Mode, 1% BER @ 2-GFSK BT = 0.5 | DR = 0.3 kbps, FDEV = 0.25 kHz, CHF = 1 kHz | | -128 | | dBm |
| | DR = 1.2 kbps, FDEV = 1.2 kHz, CHF = 4 kHz | | -122 | | dBm |
| | DR = 38.4 kbps, FDEV = 20 kHz, CHF = 100 kHz | | -109 | | dBm |
| | DR = 100 kbps, FDEV = 50 kHz, CHF = 200 kHz | | -105 | | dBm |
| Sensitivity @ 920MHz, Low Gain Mode, 1% BER @ 4-GFSK BT = 0.5 | DR = 4.8 kbps, DEV = 2.4 kHz, CHF = 10 kHz | | -114 | | dBm |
| | DR = 9.6 kbps, DEV = 4.8 kHz, CHF = 20 kHz | | -112 | | dBm |
| | DR = 19.2 kbps, DEV = 9.6 kHz, CHF = 40 kHz | | -108 | | dBm |
| Sensitivity @ 920MHz, Low Gain Mode, 1% BER @ OOK | DR = 0.3 kbps, CHF = 1 kHz | | -121 | | dBm |
| | DR = 1.2 kbps, CHF = 4 kHz | | -118 | | dBm |
| | DR = 38.4 kbps, CHF = 100 kHz | | -105 | | dBm |
| | DR = 125 kbps, CHF = 250 kHz | | -100 | | dBm |
| Maximum Output Power ⁽³⁾ | At U.FL connector | | +27 | | dBm |
| Minimum Output Power | At U.FL connector | | 0 | | dBm |

- (1) The frequency range of Sigfox RC-2 and FCC Part 15.257 is 902.1375MHz to 904.6625MHz
- (2) The frequency range of Sigfox RC-4 and NCC is 920.1375MHz to 922.6625MHz
- (3) The maximum output power in FCC certification report is 25.29 dBm. The maximum output power in NCC certification report is 24.88 dBm,

4.7. Internal 16-MHz Crystal Oscillator (for BlueNRG-1)

over operating free-air temperature range (unless otherwise noted)

| Parameter | Test Conditions | Min | Typ | Max | Units |
|--|-----------------|-----|-----|-----|-------|
| Crystal frequency | | | 16 | | MHz |
| Crystal frequency tolerance ⁽¹⁾ | | -40 | | +40 | ppm |

- (1) Includes initial tolerance of the crystal, drift over temperature, aging (5 years).

4.8. Internal 32.768-kHz Crystal Oscillator (for BlueNRG-1)

over operating free-air temperature range (unless otherwise noted)

| Parameter | Test Conditions | Min | Typ | Max | Units |
|--|-----------------|-----|--------|-----|-------|
| Crystal frequency | | | 32.768 | | KHz |
| Crystal frequency tolerance ⁽¹⁾ | | -40 | | 40 | ppm |

- (1) Includes initial tolerance of the crystal, drift over temperature, aging (5 years).

4.9. Internal 50MHz Crystal Oscillator (for S2-LP)

over operating free-air temperature range (unless otherwise noted)

| Parameter | Test Conditions | Min | Typ | Max | Units |
|--|---|-----|-----|-----|-------|
| Crystal frequency | | | 50 | | MHz |
| Crystal frequency tolerance ⁽¹⁾ | Without initial frequency calibration | -40 | | 40 | ppm |
| Crystal frequency tolerance ⁽²⁾ | Initial frequency is calibrated by software | -20 | | 20 | ppm |

(1) Includes initial tolerance of the crystal, drift over temperature, aging (5 years).

(2) Includes only drift over temperature, aging (5 years).

4.10. BlueNRG-1 Digital I/O specifications

Ta = 25°C

| Parameter | Test Conditions | Min | Typ | Max | Units |
|-----------------------------|-----------------------------|---------|-----|---------|-------|
| Trise | 0.1*VDD to 0.9*VDD, CL=50pF | 1.4(TC) | - | 19(TC2) | ns |
| Tfall | 0.9*VDD to 0.1*VDD, CL=50pF | 1.5(TC) | - | 22(TC2) | ns |
| T(RST)L | | - | 1.5 | - | ms |
| TC | | 3 | 3.3 | 3.6 | V |
| TC1 | | 2.25 | 2.5 | 2.75 | V |
| TC2 | | 1.72 | 1.8 | 1.98 | V |
| VIL | TC | -0.3 | - | 0.9 | V |
| | TC1 | -0.3 | - | 0.67 | V |
| | TC2 | -0.3 | - | 0.54 | V |
| VIH | TC | 1.95 | - | 3.6 | V |
| | TC1 | 1.46 | - | 2.75 | V |
| | TC2 | 1.1 | - | 1.98 | V |
| VOL | TC | - | - | 0.4 | V |
| | TC1 | - | - | 0.42 | V |
| | TC2 | - | - | 0.45 | V |
| VOH | TC | 2.4 | - | - | V |
| | TC1 | 1.72 | - | - | V |
| | TC2 | 1.35 | - | - | V |
| IOL (Low drive strength) | TC (VOL = 0.4V) | 3.4 | 5.6 | 7.9 | mA |
| | TC1 (VOL= 0.42V) | 3.8 | 6.6 | 10.1 | mA |
| | TC2 (VOL =0.45V) | 1.6 | 3 | 5 | mA |

| | | | | | |
|------------------------------|------------------|-----|------|------|----|
| IOL (High drive strength) | TC (VOL = 0.4V) | 6.8 | 11.2 | 15.8 | mA |
| | TC1 (VOL= 0.42V) | 7.6 | 13.2 | 20.1 | mA |
| | TC2 (VOL =0.45V) | 3.3 | 6 | 9.9 | mA |
| IOH (Low drive strength) | TC (VOH = 2.4V) | 5.5 | 10.6 | 17.6 | mA |
| | TC1 (VOH= 1.72V) | 3.7 | 7.2 | 12 | mA |
| | TC2 (VOH =1.35V) | 1.4 | 3 | 5.6 | mA |
| IOH (High drive strength) | TC (VOH = 2.4V) | 9.9 | 19.2 | 31.7 | mA |
| | TC1 (VOH= 1.72V) | 6.7 | 12.9 | 21.6 | mA |
| | TC2 (VOH =1.35V) | 2.4 | 5.5 | 10.1 | mA |

4.11. S2-LP Digital interface specification

| Parameter | Test Conditions | Min | Typ | Max | Units |
|---------------------|--|---------------------------|-----|--------------------|-------|
| SPI clock frequency | | | 8 | 10 | MHz |
| VIH | | $VCC_S2LP/2+0.3$ | - | - | V |
| VIL | | - | - | $VCC_S2LP/8 +0.3$ | V |
| VOH | IOH = -2.4 mA (-4.2 mA into high output current mode). | $0.625 * VCC_S2LP + 0.1$ | - | - | V |
| VOL | IOL = +2.0 mA (+4.0 mA into high output current mode). | | | 0.5 | V |

4.12. RFX1010 Digital interface specification

| Parameter | Test Conditions | Min | Typ | Max | Units |
|----------------------|---------------------------|-----|-----|--------|-------|
| Control Voltage High | RXEN, TXEN, and MODE Pins | 1.2 | - | VCC_PA | V |
| Control Voltage Low | RXEN, TXEN, and MODE Pins | | | 0.3 | V |

4.13. RFX1010 Gain vs. Pout

Tc = 25°C, VCC_PA = 3.3 V

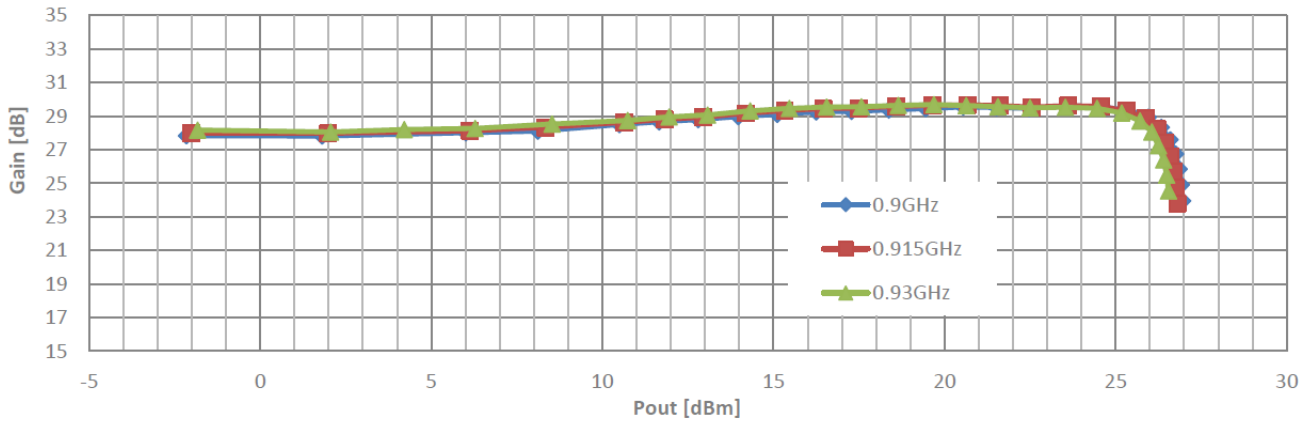

4.14. RFX1010 CW Current vs. Pout

Tc = 25°C, VCC_PA = 3.3V

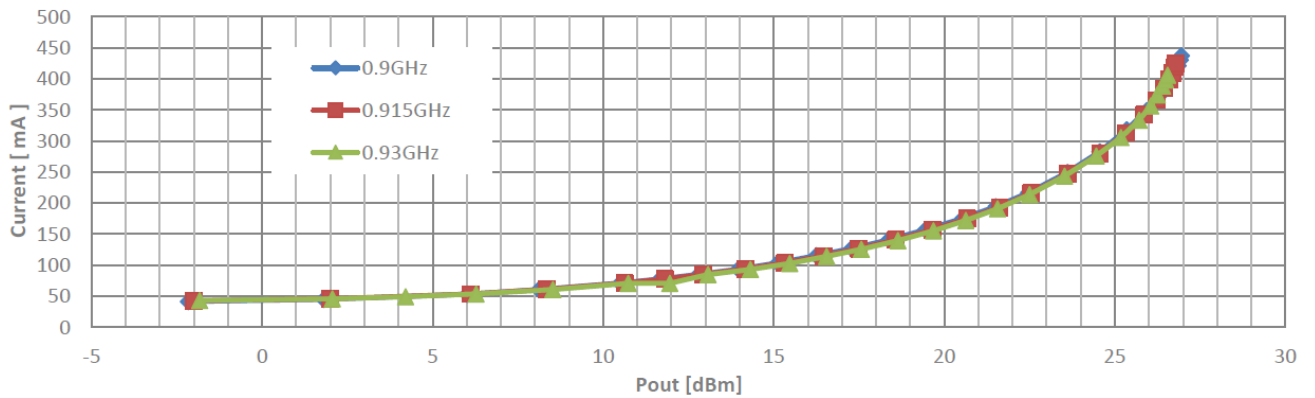

4.15. RFX1010 Vdet vs. Pout

Tc = 25°C, VCC_PA = 3.3 V, Measured with 10kΩ load.

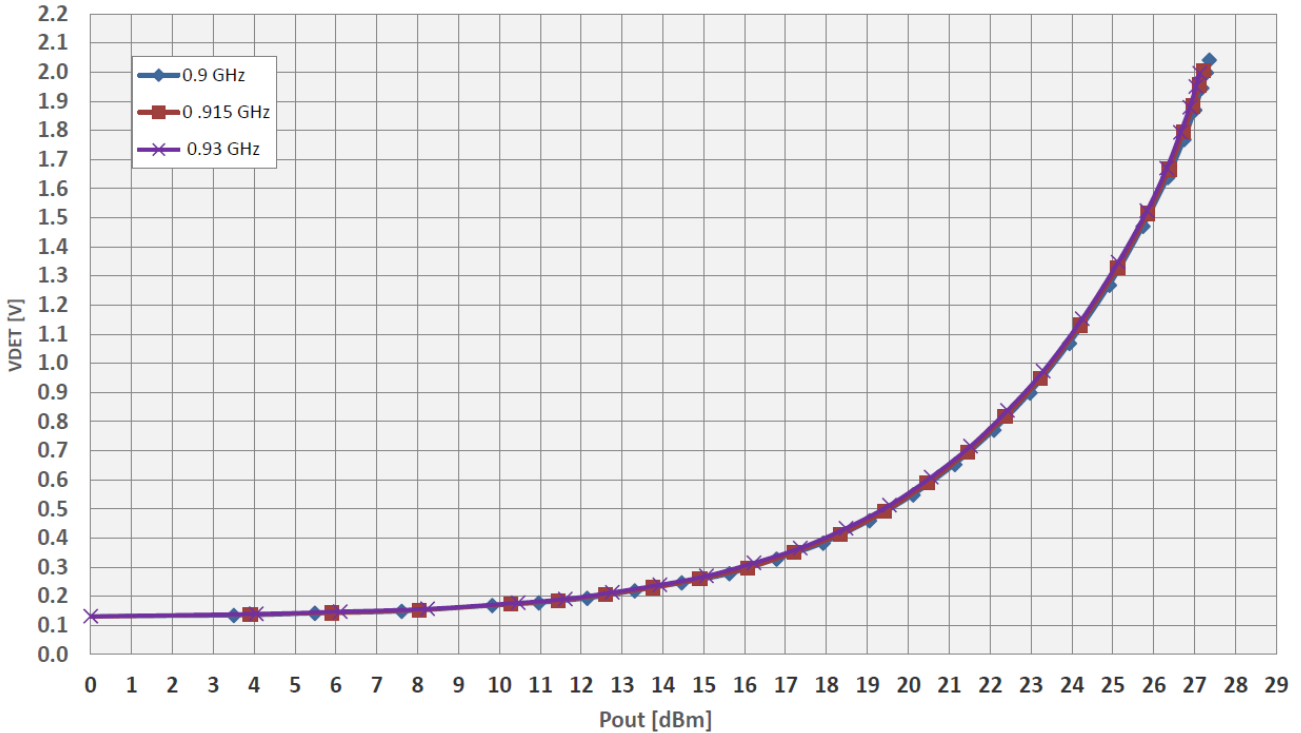

4.16. More Characteristics

If you need more detail characteristics, please visit STM and Skyworks web site.

BlueNRG-1:

http://www.st.com/content/st_com/en/products/wireless-connectivity/bluetooth-bluetooth-low-energy/bluenrg-1.html

S2-LP:

http://www.st.com/content/st_com/en/products/wireless-connectivity/sub-1ghz-rf/s2-lp.html

RFX1010:

<http://www.skyworksinc.com/Product/3212/RFX1010>

5. DESIGN RECOMMENDATIONS

5.1. GPIO Usage of BlueNRG-1

Because the function of some pins has been used in the module internally, the other functions of these pins can not be defined. Please refer the below table.

| Pin Name | Mode "000" | | Mode "001" | | Mode "100" | | Mode "101" | | Note |
|----------|------------|-------------------|------------|---------------------|------------|---------------------|------------|--------------------|-----------------------------|
| | Type | Signal | Type | Signal | Type | Signal | Type | Signal | |
| DIO0 | I/O | GPIO 0 | I | UART_CTS | I/O | SPI_CLK | - | - | To SCLK pin of S2-LP |
| DIO1 | I/O | GPIO 1 | O | UART_RTS | I/O | SPI_CS1 | I | PDM_DAT | To CS pin of S2-LP |
| DIO2 | I/O | GPIO 2 | O | PWM0 | O | SPI_OUT | O | PDM_CLK | To SDI pin of S2-LP |
| DIO3 | I/O | GPIO 3 | O | PWM1 | I | SPI_IN | O | - | To SDO pin of S2-LP |
| DIO4 | I/O | GPIO 4 | I | UART_RXD | I/O | I2C2_CLK | O | PWM0 | To SCL pin of STSAFE-A1SX |
| DIO5 | I/O | GPIO 5 | O | UART_TXD | I/O | I2C2_DAT | O | PWM1 | To SDA pin of STSAFE-A1SX |
| DIO6 | I/O | GPIO 6 | O | UART_RTS | I/O | I2C2_CLK | I | PDM_DAT | To reset pin of STSAFE-A1SX |
| DIO7 | I/O | GPIO 7 | I | UART_CTS | I/O | I2C2_DAT | O | PDM_CLK | |
| DIO8 | I/O | GPIO 8 | O | UART_TXD | I/O | SPI_CLK | I | PDM_DAT | |
| DIO9 | I/O | GPIO 9 | I | SWCLK | I | SPI_IN | - | - | |
| DIO10 | I/O | GPIO 10 | I | SWDIO | O | SPI_OUT | - | - | |
| DIO11 | I/O | GPIO 11 | I | UART_RXD | I/O | SPI_CS1 | - | - | |
| DIO12 | OD | GPIO 12 | I | - | I/O | I2C1_CLK | - | - | |
| DIO13 | OD | GPIO 13 | I | UART_CTS | I/O | I2C1_DAT | - | - | To GPIO3 pin of S2-LP |
| DIO14 | I/O | GPIO 14 | I/O | I2C1_CLK | I/O | SPI_CLK | O | - | To SDN pin of S2-LP |

5.2. Power Voltage Range

There are 3 key chips in this module, and they have their own separate power pins. In the different I/O level application, we suggest to refer the below power source design.

| Interface I/O level | Power pin in the WS2119-A0 | | |
|---------------------|----------------------------|----------|--------|
| | VBAT | VCC_S2LP | VCC_PA |
| 3.3V | 3.3V | 3.3V | 3.3V |
| 2.5V | 2.5V | 2.5V | 3.3V |
| 1.8V | 1.8V | 1.8V | 3.3V |

5.3. Debug Port

The BlueNRG-1 embeds the ARM serial wire debug (SWD) port. It is two pins (clock and single bi-directional data) debug interface, providing all the debug functionality plus realtime access to system memory without halting the processor or requiring any target resident code.

| Pin functionality | Pin Name | Pin description |
|-------------------|----------|------------------|
| SWCLK | DIO9 | SWD clock signal |
| SWDIO | DIO10 | SWD data signal |

The Cortex-M0 subsystem of the BlueNRG-1 embeds two breakpoints and one watch point.

5.4. Debugging Tips

There are certain situations where debug access is disabled and the chip cannot be accessed, including:

- application that disables debug pins
- application that set the device in sleep or standby state, in which the debug port is not powered.

These cases are common during application development and device can end up in a state where debug access is no longer possible. To recover this situation, it is recommended to force DIO7 pin high and hardware reset the device in order to force execution of the updater code. The user can then connect with SWD interface and erase the device Flash memory.

5.5. Pre-programmed bootloader

BlueNRG-1 device has a pre-programmed bootloader supporting UART protocol with automatic baudrate detection. Main features of the embedded bootloader are:

- Auto baudrate detection up to 460 kbps
- Flash mass erase, section erase
- Flash programming
- Flash readout protection enable/disable

The pre-programmed bootloader is an application which is stored on the BlueNRG-1 internal ROM

at manufacturing time by STMicroelectronics. This application allows upgrading the device Flash with a user application using a serial communication channel (UART).

Bootloader is activated by hardware by forcing IO7 high during power-up or hardware Reset, otherwise, application residing in Flash will be launched.

The customer application must ensure that IO7 is forced low during power up.

5.6. Antenna Selection Guide

There are two U.FL connectors to connect one 2.4GHz antenna and one 915MHz antenna. There is an antenna selection guide from STM. You can download it from the below link.

http://www.st.com/content/ccc/resource/technical/document/application_note/82/38/3f/9f/fd/4d/4f/ab/DM00068254.pdf/files/DM00068254.pdf/jcr:content/translations/en.DM00068254.pdf

For the FCC and NCC certified antenna types/gain please refer to the following table.

| Antenna Type | BT LE | | Sigfox | |
|--------------|---------|---------|--------|----------|
| | PCB | Dipole | PCB | Dipole |
| Antenna Gain | 3.3 dBi | 2.6 dBi | 2 dBi | 3.53 dBi |

The maximum antenna gain allowed for use with this device is 3.3 dBi for BT LE and 3.53 dBi for Sigfox.

5.7. Reference Schematic

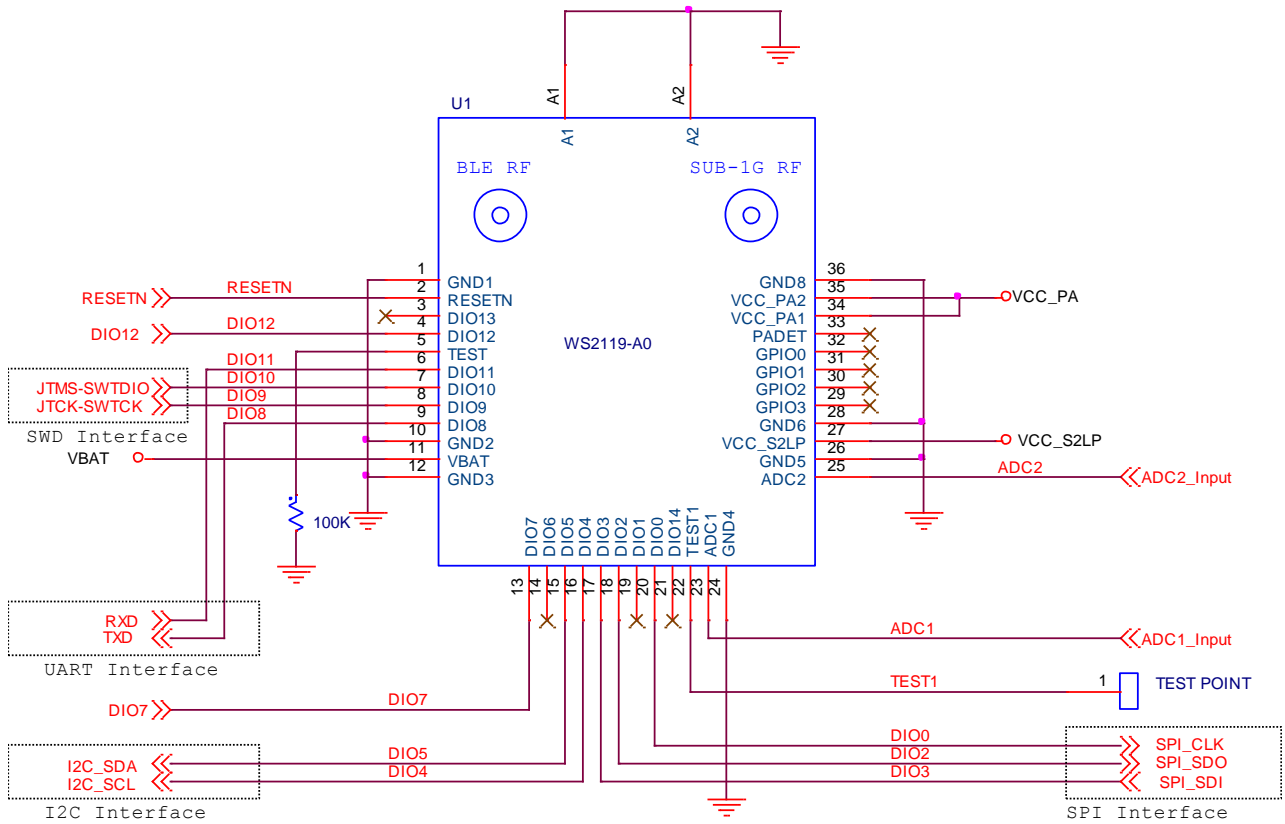

5.8. Module Layout Recommendations

- Power Trace – Power trace for VCC_PA should be 25mil wide. VBAT and VCC_S2LP traces should be 15mil wide, at least.

6. PACKAGE INFORMATION

6.1. Module Mechanical Outline

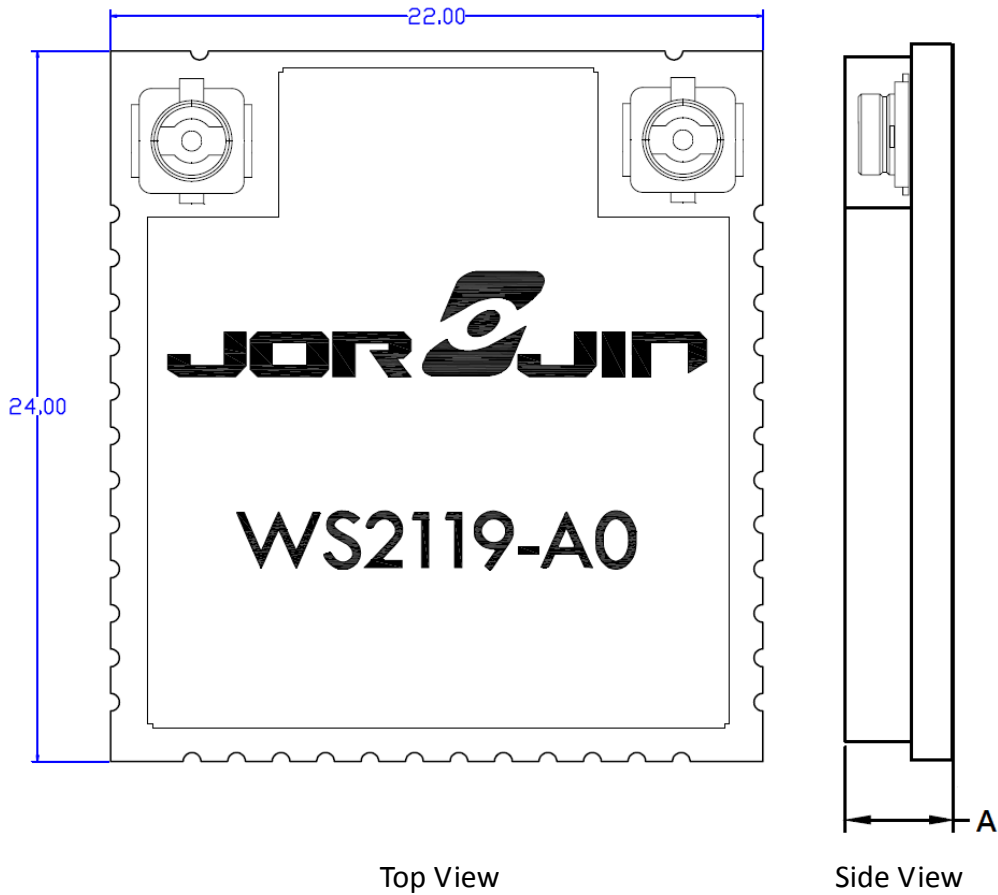

Note:

A: Typical: 2.8mm, Maximum: 3.0mm

Unit: mm

Tolerance: +/- 0.2mm

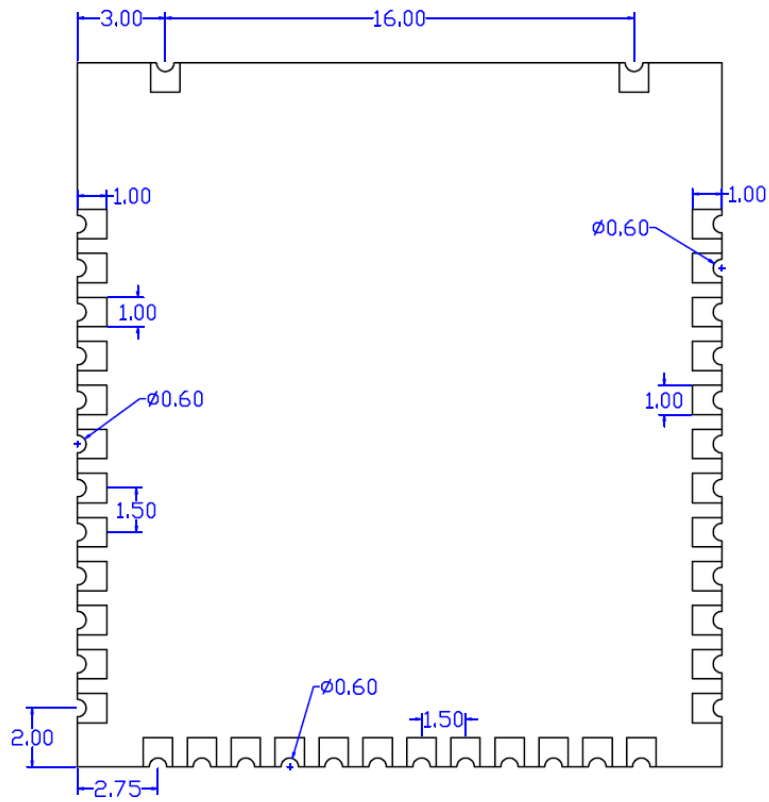





Bottom View

Note:

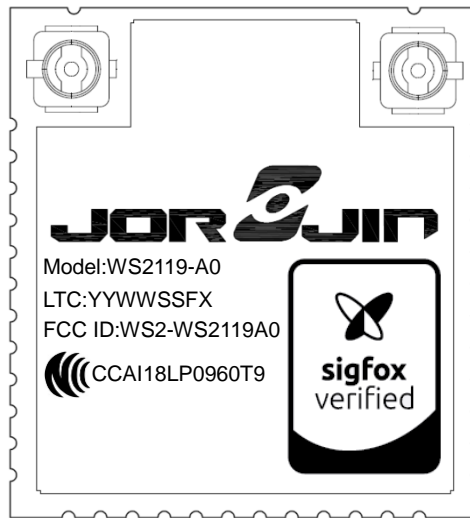
- 1> Pad tolerance as +/-30um
- 2> Unit: mm

6.2. Package Marking



| Marking | Description |
|---|---|
|  | Brand name: JORJIN |
| WS2119-A0 or WS2119-F0 | Model name |
| YYWWSSFX | Lot Trace Code: YYWWSSFX YY= Digit of the year, ex: 2017=17 WW= Week (01~52) SS= Serial number from 01~98 match to MFG's lot number, or 99 to repair control code F= Reverse for internal use X = A for Module version |
| WS2-WS2119A0 | FCC ID |
|  | NCC compliance mark, and ID NCC ID of WS2119-A0 : CCAI18LP0960T9 NCC ID of WS2119-F0 : CCAI18LP096AT1 |
|  | Sigfox P1 certified logo |

7. SMT AND BAKING RECOMMENDATION

7.1. Baking Recommendation

- Baking condition :
 - Follow MSL Level 4 to do baking process.
 - After bag is opened, devices that will be subjected to reflow solder or other high temperature process must be
 - a) Mounted within 72 hours of factory conditions <30°C/60% RH, or
 - b) Stored at <10% RH.
 - Devices require bake, before mounting, if Humidity Indicator Card reads >10%
- If baking is required, Devices may be baked for 8 hrs. at 125 °C.

7.2. SMT Recommendation

- Recommended Reflow profile :

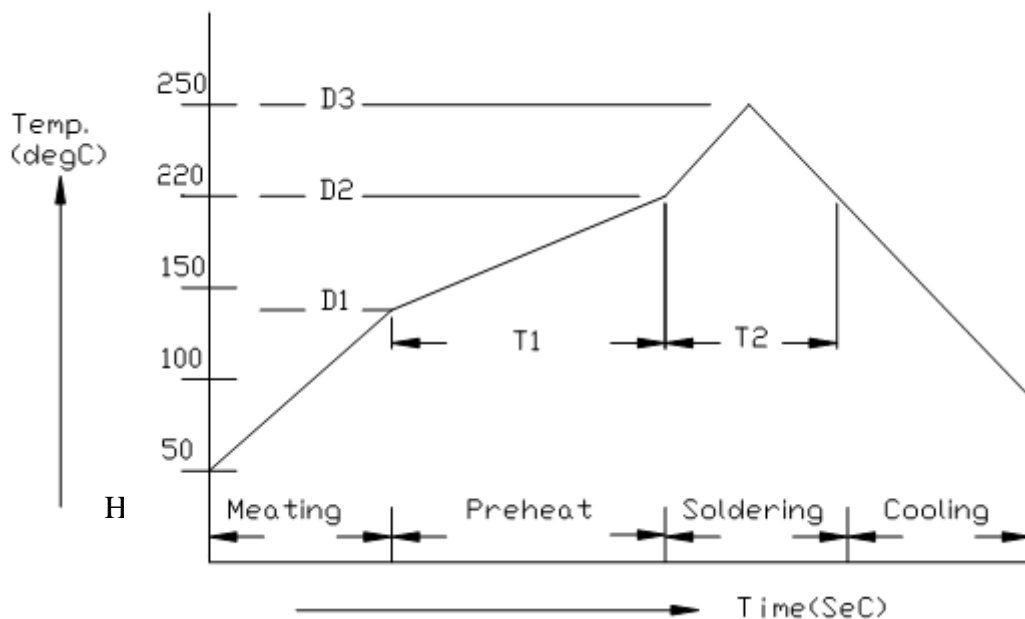

| No. | Item | Temperature (°C) | Time (sec) |
|-----|------------|-------------------|---------------|
| 1 | Pre-heat | D1: 140 ~ D2: 200 | T1: 80 ~ 120 |
| 2 | Soldering | D2: = 220 | T2: 60 +/- 10 |
| 3 | Peak-Temp. | D3: 250 °C max | |

Note: (1) Reflow soldering is recommended two times maximum.

(7) Add Nitrogen while Reflow process : SMT solder ability will be better.

- **Stencil thickness** : 0.1~ 0.13 mm (Recommended)
- **Soldering paste (without Pb)** : Recommended SENJU N705-GRN3360-K2-V can get better soldering effects.

8. REGULATORY INFORMATION

This section outlines the regulatory information for the following countries:

- United States
- Taiwan

8.1. United States

Federal Communications Commission Interference Statement

This device complies with Part 15 of the FCC Rules. Operation is subject to the following two conditions: (1) This device may not cause harmful interference, and (2) this device must accept any interference received, including interference that may cause undesired operation.

This equipment has been tested and found to comply with the limits for a Class B digital device, pursuant to Part 15 of the FCC Rules. These limits are designed to provide reasonable protection against harmful interference in a residential installation. This equipment generates, uses and can radiate radio frequency energy and, if not installed and used in accordance with the instructions, may cause harmful interference to radio communications. However, there is no guarantee that interference will not occur in a particular installation. If this equipment does cause harmful interference to radio or television reception, which can be determined by turning the equipment off and on, the user is encouraged to try to correct the interference by one of the following measures:

- Reorient or relocate the receiving antenna.
- Increase the separation between the equipment and receiver.
- Connect the equipment into an outlet on a circuit different from that to which the receiver is connected.
- Consult the dealer or an experienced radio/TV technician for help.

FCC Caution:

- Any changes or modifications not expressly approved by the party responsible for compliance could void the user's authority to operate this equipment.
- This transmitter must not be co-located or operating in conjunction with any other antenna or transmitter.

FCC RF Radiation Exposure Statement:

This equipment complies with FCC radiation exposure limits set forth for an uncontrolled environment. This equipment should be installed and operated with minimum distance 20cm between the radiator & your body.

This device is intended only for OEM integrators under the following conditions:

- 1) The antenna must be installed such that 20 cm is maintained between the antenna and users, and
- 2) The transmitter module may not be co-located with any other transmitter or antenna.

As long as **2** conditions above are met, further transmitter test will not be required. However, the OEM integrator is still responsible for testing their end-product for any additional compliance requirements required with this module installed

IMPORTANT NOTE: In the event that these conditions can not be met (for example certain laptop configurations or co-location with another transmitter), then the FCC authorization is no longer considered valid and the FCC ID can not be used on the final product. In these circumstances, the OEM integrator will be responsible for re-evaluating the end product (including the transmitter) and obtaining a separate FCC authorization.

End Product Labeling:

This transmitter module is authorized only for use in device where the antenna may be installed such that 20 cm may be maintained between the antenna and users. The final end product must be labeled in a visible area with the following: "Contains FCC ID:WS2-WS2119A0". The grantee's FCC ID can be used only when all FCC compliance requirements are met.

Manual Information to the End User

The OEM integrator has to be aware not to provide information to the end user regarding how to install or remove this RF module in the user's manual of the end product which integrates this module.

The end user manual shall include all required regulatory information/warning as show in this manual.

8.2. Taiwan

The WS2119-A0 is certified as a module with type certification number  CCAI18LP0960T9.

The WS2119-F0 is certified as a module with type certification number  CCAI18LP096AT1.

End product can display the certification label of the embedded module.

本產品內含射頻模組: CCAI18LP0960T9

or

本產品內含射頻模組: CCAI18LP096AT1

The user's manual should contain following warning (for RF device) in traditional Chinese:

注意

本產品符合低功率電波輻射性電機管理辦法：

第十二條

經形式認證合格之低功率射頻電機，非經許可，公司、商號或使用者均不得擅自變更頻率、加大功率或變更原設計之特性及功能。

第十四條

低功率射頻電機之使用不得影響飛航安全及干擾合法通信；經發現有干擾現象時，應立即停用，並改善至無干擾時方的繼續使用。

前項合法通信，指依電信規定作業之無線電信。低功率射頻電機須忍受合法通信或工業、科學及醫療用電波輻射性電機設備之干擾。

使用 WS2119-A0 之系統廠商應於平台上標示「本產品內含射頻模組: CCAI18LP0960T9」字樣

使用 WS2119-F0 之系統廠商應於平台上標示「本產品內含射頻模組: CCAI18LP096AT1」字樣

9. HISTORY CHANGE

| Revision | Date | Description |
|----------|------------|--|
| D 0.1 | 2017/03/20 | Product Preview |
| D 0.2 | 2017/05/02 | Add "Pin Description" |
| D 0.3 | 2017/07/18 | Change PA chip to RFX1010 |
| D 0.4 | 2017/07/31 | Modify block diagram Add : 4. MODULE SPECIFICATIONS 5. DESIGN RECOMMENDATIONS 7. SMT AND BAKING RECOMMENDATION |
| D 0.5 | 2018/03/02 | Add design limitation for Sigfox |
| D 0.6 | 2018/03/21 | Add model number WS2119-F0 |
| D 0.7 | 2018/07/03 | Add "6.2. Package Marking" "8. REGULATORY INFORMATION" |