

RMS320

Radar measurement sensor

SICK
Sensor Intelligence.



Described product

RMS320

Manufacturer

SICK AG
Erwin-Sick-Str. 1
79183 Waldkirch
Germany

Copyright

This work is protected by copyright. Any rights derived from the copyright shall be reserved for SICK AG. Reproducing of this document or parts of this document is only permissible within the limits of the legal determination of Copyright Law. Any modification, expurgation or translation of this document is prohibited without the express written permission of SICK AG.

© SICK AG. All rights reserved.

Original document

This document is an original document of SICK AG.

Table of contents

| | | |
|------------|--|-----------|
| 1 | About this Document..... | 4 |
| 1.1 | Scope | 4 |
| 1.2 | Depth of information | 4 |
| 2 | For your safety..... | 5 |
| 2.1 | General safety notes and protective measures | 5 |
| 2.2 | Warning notices on device..... | 6 |
| 2.3 | Intended use of device..... | 6 |
| 2.4 | Non-intended use..... | 6 |
| 2.5 | Authorized personnel | 7 |
| 3 | Product description..... | 8 |
| 3.1 | Delivery | 8 |
| 4 | Electrical Installation | 9 |
| 4.1 | Connectivity | 9 |
| 5 | Configuration | 13 |
| 5.1 | Requirements | 13 |
| 5.2 | Switch on | 13 |
| 5.3 | Main screens | 13 |
| 5.4 | System configuration | 14 |
| 5.5 | Service | 14 |
| 6 | Startup and operation | 15 |
| 6.1 | Status indicators | 16 |
| 7 | Troubleshooting | 17 |
| 7.1 | Safety | 17 |
| 7.2 | Monitoring error and malfunction indications (LED) | 17 |
| 7.3 | Troubleshooting and rectification table | 17 |
| 8 | Technical data | 18 |
| 8.1 | Dimensional Drawing | 18 |
| 8.2 | Technical Data..... | 19 |
| 9 | Accessories..... | 21 |
| 9.1 | Weather hood | 21 |
| 9.2 | Mounting..... | 22 |
| 10 | Appendix..... | 23 |
| 10.1 | Conformities | 23 |
| 10.2 | Approvals | 23 |
| 10.3 | Lizenzen | 24 |

1 About this Document

Information regarding the operating instructions

These operating instructions provide important information on how to handle Radar Measurement Systems from SICK AG.

Prerequisites for working safely are:

- Adherence to all the specified safety instructions and guidelines.
- Complying with any local work safety regulations and general safety specifications applicable to the use of the Radar Measurement System

These operating instructions are intended for specialists and electricians.

Important Read these instructions carefully before starting any work on the device to familiarize yourself with the RMS320 Radar Measurement System and its functions.

The operating instructions are considered a part of the device and must be kept in an accessible location in the immediate vicinity of the device at all times, optimally in printed format. Should the device be passed on to a third party, these operating instructions should be handed over with it.

These operating instructions do not provide information on operating the machine in which the Radar Measurement System is integrated. For information about this, refer to the operating instructions of the respective machine.

1.1 Scope

These operating instructions are designed to address the technical personnel in regards to safe mounting, electrical installation, commissioning and configuration and maintenance of the following laser measurement sensor variants.

A step-by-step approach is taken for all tasks.

1.2 Depth of information

These operating instructions contain the following information on the RMS320.

- Product description
- Transport and storage
- Mounting
- Electrical installation
- Commissioning and configuration
- Maintenance
- Troubleshooting
- Technical data

In addition, an online help is available in the SOPAS ET configuration software supplied; this help provides information on the usage of the software user interface, as well as on the configuration of the RMS320.

You will find a detailed description of the different telegrams for the RMS320 in the document “Telegram Listing Radar Measurement System”, part no.: 8021531, English version.

You will find further information on the LMS5xx, its accessories as well as documents on the online product page [www.sick.com/rms320].

2 For your safety

2.1 General safety notes and protective measures

Please observe the following items in order to ensure the correct and safe use of the RMS320.

- The notices in these operating instructions (e.g. on use, mounting, installation or integration into the existing machine controller) must be observed.
- When operating the RMS320, the national, local and statutory rules and regulations must be observed.
- National/international rules and regulations apply to the installation, commissioning, use and periodic technical inspections of the MRS320, in particular
 - the work safety regulations/safety rules
 - other relevant health and safety regulations.
- Manufacturers and operators of the machine/system on which the RMS320 is installed are responsible for obtaining and observing all applicable safety regulations and rules.
- The tests must be carried out by specialist personnel or specially qualified and authorized personnel and must be recorded and documented to ensure that the tests can be reconstructed and retraced at any time.
- The operating instructions must be made available to the operator of the system where the RMS320 is used. The operator of the system is to be instructed in the use of the device by specialist personnel and must be instructed to read the operating instructions.
- The RMS320 is not a device for the protection of people in the context of the related safety standards for machinery.

2.1.1 Quick stop and quick restart

2.1.1.1 Switch the RMS320 off

- Switch off the voltage supply (power supply) for the RMS320

The RMS320 retains parameters stored in the internal, non-volatile memory. Measured values in the memory are lost.

2.1.1.2 Switch the RMS320 on

- Switch on the voltage supply (power supply) for the RMS320

The RMS320 restarts operation with the last saved parameters.

2.1.2 RADAR

General/Intended use

The RMS320 sensor is designed for both indoor and outdoor area monitoring. Within a defined detection area, the sensor detects static and moving objects, and triggers a I/O signal upon detection of a corresponding object. Distance zones can be defined and have various functions assigned to them.

The RMS320 is designed for detection of objects within the operating range. In case an object has been detected the integrated I/O will provide a signal. Additionally the resting time of the objects, the speed and direction of movement within the detection range will be calculated and provided via the data telegram.

The RMS320 and the SICK firmware is designed to visualize and control objects within the operating range. All object data can be provided via Ethernet. The RMS320 is prepared to provide the object data also via the CAN protocol.

To operate the RMS320 the software SOPAS ET by SICK AG needs to be used. A more detailed description of the software and parameters are listed in this document.

2.1.2.1 Health hazard as a result of high-frequency electromagnetic radiation!

The RMS30 is designed for operation in accordance with ETSI EN 300 440. During operation the human exposure regulations covered by EN 62311 must be observed.

In order to limit human exposure to electromagnetic fields, suitable safety distances must be maintained during both short-term and long-term work in the radiation range of the antenna(s).

Minimum distances to be maintained between the antenna and the human body during continuous transmission: 20 cm.

The RMS320 satisfies the limit values of the FCC for exposure to radiation in an uncontrolled environment.

For country-specific particulars to consider when operating the RMS320, see chapter “Operational restrictions” in this document.

2.2 Warning notices on device

Before setting the RMS320 into operation please consider the warning instructions placed on the back side of the RMS320 housing and the safety notes in this document.

2.3 Intended use of device

Notice:

The RMS320 sensor is intended for use in industrial environments. It is not intended for safety applications e.g. protection of humans.

The RMS320 is used to determine objects within the detection zone according to the technical datasheet. After fitting and setting into operation the RMS320 continuously detects the area of the detection zone. Once objects will be detected the RMS320 provides the actual status via the I/O outputs and/or the data output protocol. These signals will be provided as long as the object is detected inside of the detection zone.

Important:

In case of any other usage as well as in case of modifications to the RMS320, e.g. due to opening the housing during mounting and electrical installation, or to the SICK software, any claims against SICK AG under the warranty will be rendered void.

Notice:

The RMS320 is only allowed to be operated in the ambient temperature range allowed as described in the technical data sheet.

2.4 Non-intended use

The RMS320 is not designed for safety applications, detection of humans and safety applications.

2.5 Authorized personnel

The RMS320 must only be installed, commissioned and serviced by adequately qualified personnel. Repairs to the RMS320 are only allowed to be undertaken by trained and authorized service personnel from SICK AG.

The following qualifications are necessary for the various tasks:

| Activities | Qualification |
|--|--|
| Mounting and Maintenance | <ul style="list-style-type: none"> • Basic technical training • Knowledge of the current safety regulations in the workplace |
| Electrical installation and replacement | <ul style="list-style-type: none"> • Practical electrical training • Knowledge of current safety regulations • Knowledge on the use and operations of devices in the related application (e.g. cranes, assembly systems, special vehicles) |
| Commissioning, operation and configuration | <ul style="list-style-type: none"> • Knowledge on the use and operation of the devices in the related application (e.g. cranes, assembly systems, special vehicles) • Knowledge on the software and hardware environment in the related environment (e.g. cranes, assembly systems, special vehicles) • Basic knowledge of the Windows operating system • Basic knowledge of the data transmission |

3 Product description

This chapter provides information on the special features and properties of the RMS320. It describes the construction and the operating principle of the device, in particular the different operating modes.

Read this chapter carefully before commissioning the RMS320 in order to familiarize yourself with the device and its functions.

3.1 Delivery

Scope of Delivery:

| Quantity | Component | Comment |
|----------|-----------|--|
| 1 | RMS320 | <ul style="list-style-type: none">• In the version ordered (regional assignment).• Electrical connections fitted with protective caps or plugs. |

Source for obtaining additional information

Additional information about the RMS320 and its optional accessories can be found in the following places:

Product web page for the RMS320 at: www.sick.com/rms320

- Detailed technical specifications (online data sheet)
- Technical information (supplementary information on telegrams)
- These operating instructions are available in German, English and other languages if required.
- Dimensional drawing and 3D CAD dimension models in various electronic formats
- EC declaration of conformity
- SOPAS configuration software updates

Support is also available from your sales partner: www.sick.com/worldwide .

4 Electrical Installation

The electrical installation must only be performed by electrically qualified persons.

- Standard safety requirements must be met when working on electrical systems.
- Electrical connections between the RMS320 and other devices may only be created or disconnected when there is no power to the system. Otherwise, the devices may be damaged.
- When using connecting or extension cables with an open end, make sure that bare wire ends are not touching (risk of short-circuit when the supply voltage is switched on). Wires must be appropriately insulated from each other.
- Wire cross-sections in the supply cable from the customer's power system must be designed in accordance with the applicable standards.
- All circuits connected to the RMS320 must be designed as SELV circuits.

Supply voltage

- 9V to 36 V DC supply voltage; 2A protection at the start of the feeding supply circuit.
- The voltage supply or power supply unit must satisfy SELV requirements in accordance with the currently applicable EN 60950-1. (SELV = Safety Extra Low Voltage).
- The voltage supply via a power supply unit must be capable of buffering a brief power failure of 20 ms.

NOTE

Risk of damage to the RMS320 due to possible short-circuit!

The supply voltage input for the RMS320 is designed with internal circuit protection to provide reverse polarity protection. The internal functional earth, which also corresponds to the negative pole of the supply voltage for the RMS320, is connected directly to the metal housing of the RMS320.

WARNING

Risk of injury and damage caused by electrical current!

The RMS320 is designed to be operated in a system with professional grounding of all connected devices and mounting surfaces to the same ground potential. Incorrect grounding of the RMS320 can result in equipotential bonding currents between the RMS320 and other grounded devices in the system. This can lead to hazardous voltages being applied to the metal housing, cause devices to malfunction or sustain irreparable damage, and damage the cable shield as a result of a heat increase, causing cables to set alight.

Ensure that the ground potential is the same at all grounding points. If the cable insulation is damaged, disconnect the voltage supply immediately and exchange the damaged cable.

4.1 Connectivity

Installation of the RMS320:

1. Connect the 5-pin M12 male Connector ("Power/IO") via a suitable cable (e.g., No. 6049451, 1.5 m)
2. Opt. connect the 8-pin M12 male Connector ("CAN/IO") via a suitable cable (e.g., No. 6034415, 5 m)
3. Depending on the length of the connecting cable, supply the RMS320 with 9V to 36V DC
4. After successful initialization, the "Device Ready" LED lights up green

Notice:

- Only authorized personnel are allowed to perform the electrical installation work.
- Only make and disconnect electrical connections when the device is electrically isolated.
- Select and implement wire cross-sections and their correct fuse protection as per the applicable standards.
- Do not open the housing.
- Observe the current safety regulations when working on electrical systems.

M12 8p A-coded

| Pin | Function | color |
|-----|-----------|-------|
| 1 | CAN H | Wht |
| 2 | CAN L | Brn |
| 3 | IN2 | Grn |
| 4 | GND IN1/2 | Yel |
| 5 | OUT2 | Gra |
| 6 | OUT3 | Pnk |
| 7 | GND | Blu |
| 8 | OUT4 | Red |

Dimensional drawing (Dimensions in mm (inch))

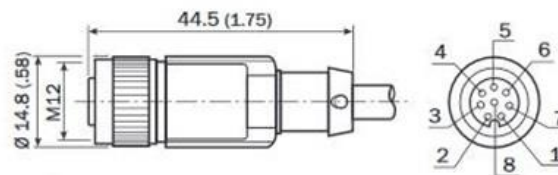

- ① Wht
- ② Brn
- ③ Grn
- ④ Yel
- ⑤ Gra
- ⑥ Pnk
- ⑦ Blu
- ⑧ Red

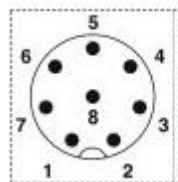

Schematic diagram
Pin assignment M12 plug, 8-pos., view
plug side

M12 5p A-coded

| Pin | Function | color |
|-----|-----------|-------|
| 1 | VS 9..36V | Brn |
| 2 | IN1 | Wht |
| 3 | GND | Blu |
| 4 | OUT1 | Blk |
| 5 | GND IN1/2 | Gra |

Dimensional drawing (Dimensions in mm (inch))

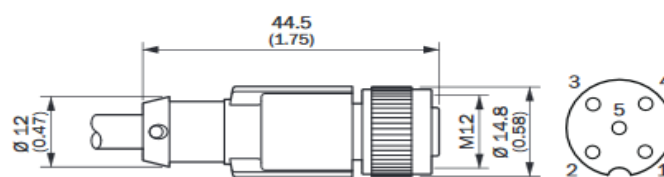

female connector M12 x1, straight, screened

- ① Brown
- ② White
- ③ Blue
- ④ Black
- ⑤ Gray

Schematic diagram

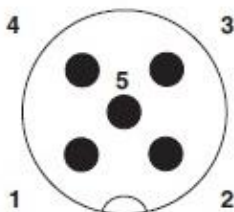

Pin assignment M12 male connector, 5-pos., A-coded, male side

M12 4p D-coded

| Pin | Signals | Function |
|-----|---------|-----------------|
| 1 | TD+ | Transmit_Data + |
| 2 | RD+ | Receive_Data + |
| 3 | TD- | Transmit_Data - |
| 4 | RD- | Receive_Data + |

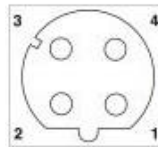

Schematic diagram
Pin assignment M12 socket, 4-pos.,
D-coded, female side

5 Configuration

5.1 Requirements

For parametrization of the RMS320 the configuration software SOPAS ET (Version 3.2.0 or higher) is necessary.

1. Download and install the latest version of the configuration tool, as well as current device description files (.sdd), from the online product page for the software: www.sick.com/sopas by following the instructions provided.
2. In this case, select the “Complete” option as selected by the installation wizard. Administrator rights may be required on the PC to install the software.
3. Start the “SOPAS ET” program option after completing the installation. Path:
 - a. Start > Programs > SICK > SOPAS ET Engineering Tool > SOPAS.
4. Establish a connection between SOPAS ET and RMS320 via the automatically opened assistant. To do so, select the RMS320 under the devices available depending on the connected communication interface, e.g., Ethernet. (Default Ethernet address:
 - IP address: 192.168.0.1, subnet mask:255.255.255.0)
5. SOPAS ET establishes communication with the RMS320 and loads the associated device description file for the RMS320.

5.2 Switch on

To switch on the device connect it to a power supply (0-36V, typically 24V).

After boot up of the device it will start to detect Radar-Targets automatically. See next chapters for hints, how to configure the RMS320.

5.3 Main screens

Basic information from the main page at SOPAS ET, like software version or operating data.

| Device Information | |
|---------------------|-----------|
| Manufacturer | SICK AG |
| Device Type | RMS3xx |
| Software Version | 0.2.3.0A |
| Frontend FW-Version | T0.0.0.19 |
| Order Number | 1234567 |
| Serial Number | 17209907 |

| Operating Data | | |
|------------------|------|-----------------|
| Power-On Counter | 11 | Operating Hours |
| | | 11.3 h |
| Power-On Hours | 0.05 | h |

| Service Information | | |
|---------------------|-------------|----------------------|
| Last Username | not defined | Last Parametrization |
| | | DD.MM.YYYY |
| | | at HH:MM |
| Last Maintenance | DD.MM.YYYY | Next Maintenance |
| | | DD.MM.YYYY |

5.4 System configuration

To change Ethernet configuration see “Ethernet” at the right side of configuration tool.

| | |
|-------------------|--|
| IP-Address | <input type="text" value="192 . 168 . 0 . 1"/> |
| Subnet-Mask | <input type="text" value="255 . 255 . 255 . 0"/> |
| Default Gateway | <input type="text" value="0 . 0 . 0 . 0"/> |
| Ethernet Aux Port | <input type="text" value="Server"/> |
| IP-Port | <input type="text" value="2111"/> |

| Frontend | | | |
|------------------------------|--|------------------------------|-------------------------------------|
| Transmit Objects | <input checked="" type="checkbox"/> | Transmit Targets | <input checked="" type="checkbox"/> |
| Wave Control | <input type="text" value="up/doppler/down/doppler"/> | | |
| max. raw-target angle (pos.) | <input type="text" value="50"/> ° | max. raw-target angle (neg.) | <input type="text" value="-50"/> ° |
| max. range of distance | <input type="text" value="5000"/> cm | min. range of distance | <input type="text" value="25"/> cm |
| max.range stationary objects | <input type="text" value="10"/> m | max.range stationary targets | <input type="text" value="20"/> m |

5.5 Service

To see system information, choose page “system-status”.

This page will appear if you are logged in as “Service”. The system information table provides information of three different levels: Information, Warning and Error.

In case of troubles use this page to get some more information about the radar system.

| System Information | | | | | | | | |
|--------------------|------------|-----------|-------------------|------|-------|---------|-----------|--|
| Type | First time | Last time | Description | Info | State | Counter | Number | |
| Information | 11:54:20 | 11:54:20 | No ethernet cable | | | 1 | 0x2000F04 | |

6 Startup and operation

The RMS320 operates fully automatically in normal operation without the intervention of an operator.

The interactive configuration is carried out using the provided SOPAS ET configuration software. The software used for this purpose runs on a PC with the operating system Windows that is connected to the RMS320 via one of the interfaces.

Use the graphic scan view in SOPAS ET to verify the generated measured values and to verify the measurement area online.

During this process, note that SOPAS ET cannot display the data in real-time and therefore does not display all measured values.















6.1 Status indicators

The LEDs signal the operational status of the RMS320.

The RMS320 has three LEDs. These visually signal the actual operational status.

The LEDs are mounted and visible on the front side of the device on the RMS320.

The following table shows the function of the LEDs:

| | Label | Short |
|----------------------------|----------------------|---|
| Aktion | Power | PWR |
| off | |  |
| bootup | |  |
| ready | |  |
| fatal error | |  |
| update running | |  |
| update finished | |  |
| | Field Eval | I/O |
| no field violated | |  |
| info field violated | |  |
| warning field violated | |  |
| | Communication | Link |
| no Link | |  |
| ethernet link | |  |
| ethernet data transmission | |  |
| CAN link | |  |
| CAN data transmission | |  |

7 Troubleshooting

Important: Claims under the warranty rendered void!

The housing screws of the RMS320 are sealed. Claims under the warranty against SICK AG will be rendered void if the seals are damaged or the device opened. The housing is only allowed to be opened by authorized service personnel.

This chapter describes how to identify and rectify errors and malfunctions during the operation of the RMS320.

7.1 Safety

Warning: Cease operation if the cause of the malfunction has not been clearly identified!

Stop the machine/system if you cannot clearly identify or allocate the error and if you cannot safely rectify the malfunction.

7.2 Monitoring error and malfunction indications (LED)

The RMS320 monitors itself in operation:

- After switching on the supply voltage the RMS320 runs through a self-test prior to initialization (loading the parameter set and initialization of the device functions); during this self-test the device checks important hardware components.
- During operation the RMS320 continuously monitors the function.
- If the RMS320 detects a device error, it indicates this situation using the LEDs (see above).
- See also chapter "Service"

7.3 Troubleshooting and rectification table

| Fault | Possible cause | Solution |
|---|---|---|
| 1. All LEDs are off | No power-supply connected | Connect to power supply |
| 2. PWR red flashing | Fatal Error; No functional radar measurement | Contact service |
| 3. I/O red permanent | Warning field violated | Object detected |
| 4. SOPAS ET cannot communicate with RMS320 | Bad connection | Check connection |
| 5. No measurements in the detection zone | No objects visible | Check detection zone orientation |
| 6. No I/O data output | No detection signals Wrong setting Bad connection | Check detection zone orientation, settings and connection |
| 7. RMS320 is not transmitting data via Ethernet / CAN | Wrong settings No connection; | Check settings and connection |

8 Technical data

8.1 Dimensional Drawing

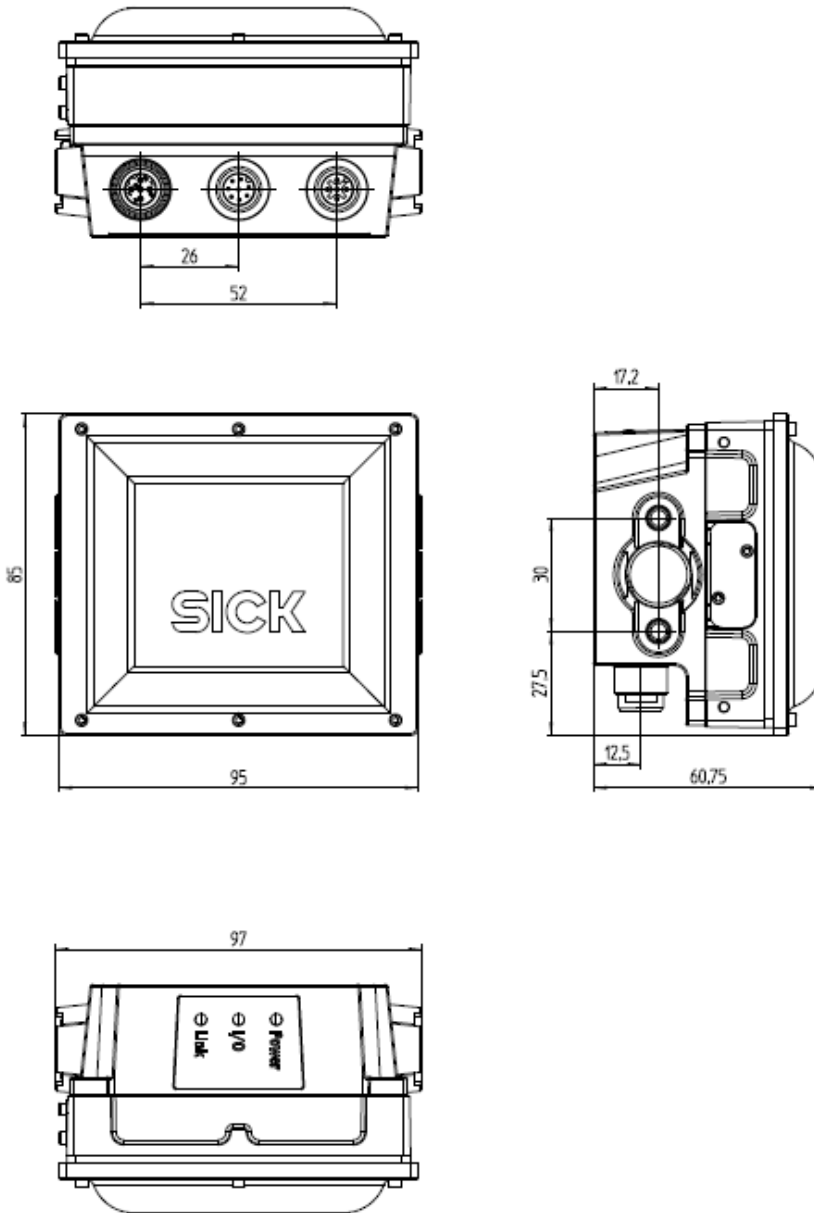

8.2 Technical Data

| | |
|---|---|
| Region assignment | Europe, USA, Canada, Japan |
| Frequency band | 24.05 ... 24.25 GHz |
| Transmitting power | +12,7 dBm e.i.r.p. |
| Max. Range on 1m ² RCS (*2) | 20 m (Typical values) |
| Max. Range on 10m ² RCS (*3) | 45 m (Typical values) |
| Min. Range | 1 m (Presence detection below is available) |
| CAN | CAN (CANopen®), 20 kBit/s ... 500 KBit/s, not terminated |
| Ethernet | Host TCP/IP, Aux TCP/IP for configuration 10/100Mbit/s |
| Digital switching inputs | 2 x Galvanically isolated from the supply voltage U _e = max. 36 V, I _e = max. 5 mA Opto decoupled, reverse polarity protected, debouncing time adjustable |
| Digital switching outputs | 4 x Galvanically not separated from the supply voltage PNP / NPN / PP configurable U _a = U _V - 1,5 V, I _a ≤ 100 mA (typical). Short Circuit Protection, temperature protected |
| Elektrical connections | <ul style="list-style-type: none"> • 1 x plug, M12, 8-pol., A-coded • 1 x plug, M12, 5-pol., A-coded • 1 x Connector female , Ethernet, 4 - pol., D-coded |
| Optical indicators | <ul style="list-style-type: none"> • 1 x RGB-LED (Power) across from M12, 5-pol. • 1 x RGB-LED (Application) across from M12, 8-pol. • 1 x RGB-LED (Ethernet-link/ CAN) across from M12, 4-pol (LED not configurable) |
| Supply voltage | SELV according to EN 60950-1. Only RMS320 FCC: SELV (EN 60950-1:2006-04) and LPS (EN 60950-1:2006-04) or Class 2 (UL 1310). DC 9 V ... 36 V during operation without SICK Connection Module. Each using a SICK line. See chapter „: Electrical Installation“ |
| Power consumption | At full transmitting power: Max. 21W (with a typical loading of the 4 switching Outputs of 100 mA each and a 36V DC supply voltage) Typically < 6 W (with no loading of switching outputs) |
| Housing/weight | Aluminum / approx.. 500g |
| Safety | EN 60950-1: 2006-04/A11: 2009-03/ A1: 2010-03/A12: 2011-02 |
| Electrical Protection class | III (EN 61140: 2006-08) |
| Enclosure rating | IP 67 (EN 60529: 1991-10/A2: 2000-02) |
| Radio approval | Europe: FINAL DRAFT ETSI EN 300 440 V2.1.1 USA: FCC Part 15.249/15.107/15.109 Canada: RSS310, ICES 003 Japan: ARIB STD-T73 |
| EMC | ETSI EN 301489-1 V2.1.1 (2017/2), Draft ETSI EN 301489-3 V2.1.1 und EN 61000 - 6 - 2 |
| Vibration resistance | EN 60068-2-6: 2008-02 |
| Shock resistance | EN 60068-2-27: 2009-05 |
| Ambient temperature range | Operation: - 40 °C ... +65 °C Storage: - 40 °C ... +85 °C |
| Relative humidity | 0 % ... 90 %, non condensing |
| Approvals | CE |
| Clock | NTP-network-time protocol, no internal clock |

- 1) UL-certified in case the UL-Logo is placed on the device
- 2) 1m² RCS typical to pedestrian
- 3) 10m² RCS typical to passenger car

Further technical data: See online datasheet at www.sick.com/RMS320

Warnings

NOTE

Operational restrictions!

The RMS320 is approved for operation in the regions according to the rows "Region assignment" and "Radio approval" in the table above. When operating in other regions protected frequencies can be disturbed.

- Only use the RMS320 in regions for which it has been approved.
- When reselling the RMS320, inform the buyer of the regional assignment.

9 Accessories

9.1 Weather hood

Dimensional Drawing:

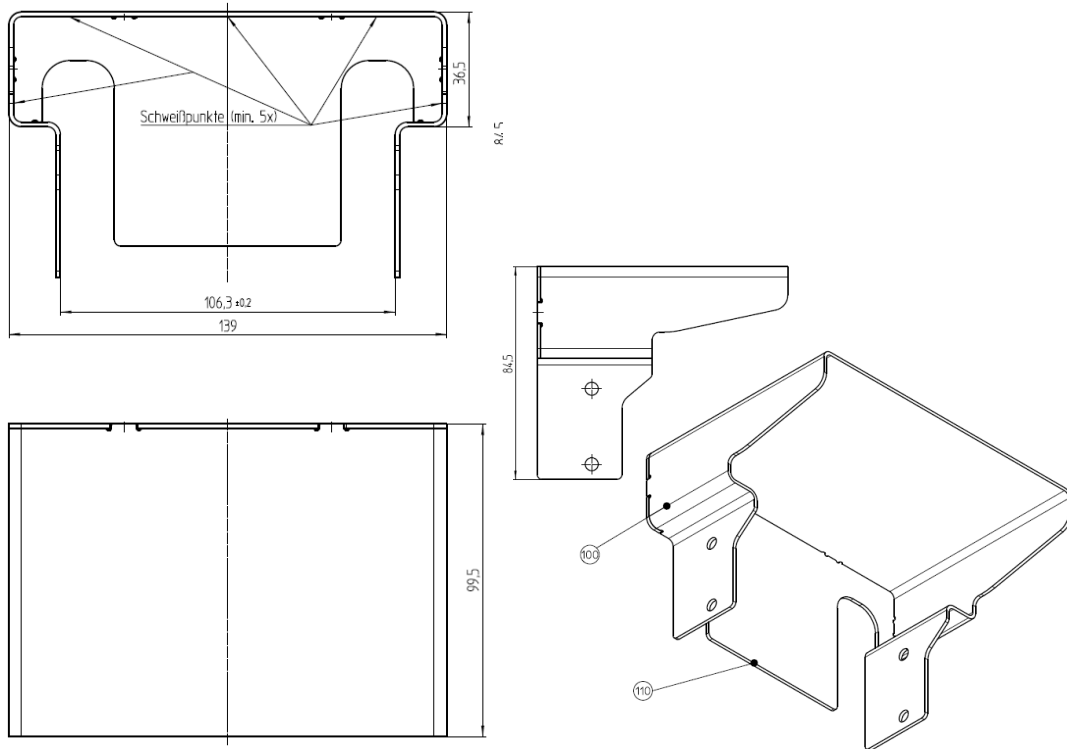

9.2 Mounting

RMS320 with angle mount:

RMS320 mit Buegelhalter (9251534)

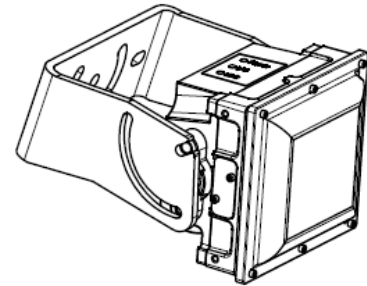
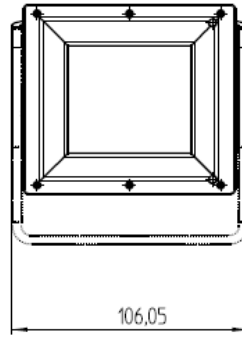
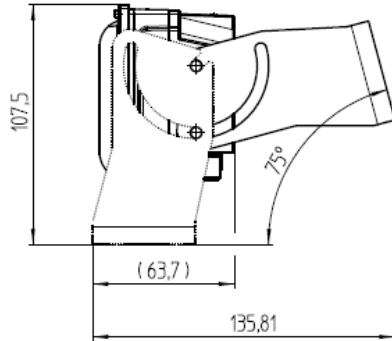

RMS320 with wall frame:

RMS320 mit Wandhalter (9251545)

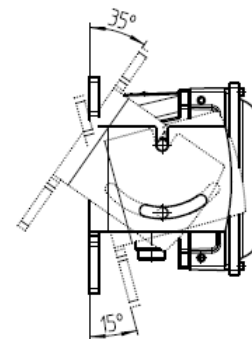
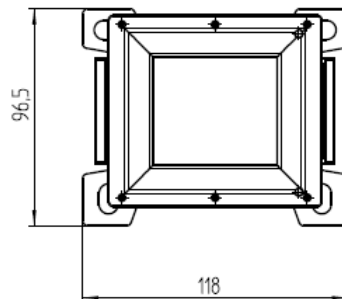
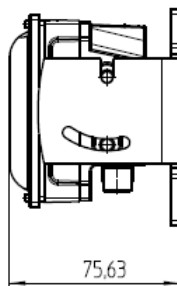

10 Appendix

10.1 Conformities

10.1.1 Europe

CE 0700

SIMPLIFIED EU DECLARATION OF CONFORMITY

Hereby, SICK AG declares that the radio equipment type RMS320 is in compliance with Directive 2014/53/EU.

The full text of the EU declaration of conformity is available at the following internet address:
www.sick.com/RMS320

10.2 Approvals

10.2.1 USA

FCC ID: WRM RMS320

(1) This device complies with part 15 of the FCC Rules. Operation is subject to the following two conditions:(1) This device may not cause harmful interference, and (2) this device must accept any interference received, including interference that may cause undesired operation.

(2) Changes or modifications not expressly approved by the party responsible for compliance could void the user's authority to operate the equipment.

(3) Note: This equipment has been tested and found to comply with the limits for a Class A digital device, pursuant to part 15 of the FCC Rules. These limits are designed to provide reasonable protection against harmful interference when the equipment is operated in a commercial environment. This equipment generates, uses, and can radiate radio frequency energy and, if not installed and used in accordance with the instruction manual, may cause harmful interference to radio communications. Operation of this equipment in a residential area is likely to cause harmful interference in which case the user will be required to correct the interference at his own expense.

(4) To comply with FCC part 15 rules in the United States, the system must be professionally installed to ensure compliance with the Part 15 certification.

(5) It is the responsibility of the operator and professional installer to ensure that only certified systems are deployed in the United States. The use of the system in any other combination (such as co-located antennas transmitting the same information) is expressly forbidden.

(6) This equipment complies with FCC radiation exposure limits set forth for an uncontrolled environment. This equipment should be installed and operated with minimum distance 30 cm between the radiator and your body.

10.2.2 Canada

This device complies with Industry Canada's RSS-310. Operation is subject to the condition that this device must not cause harmful interference and must accept any interference, including interference that may cause undesired operation of the device.

Cet appareil est conforme au CNR-310 d'Industrie Canada. Son exploitation est autorisée à condition que l'appareil ne produise pas de brouillage préjudiciable et qu'il accepte tout brouillage, même celui susceptible d'en compromettre le fonctionnement.

10.2.3 Japan

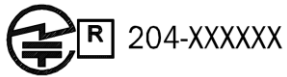

10.3 Licenses

SICK uses open-source software. This software is licensed by the rights holders using the following licenses among others: the free licenses GNU General Public License (GPL Version2, GPL Version3) and GNU Lesser General Public License (LGPL), the MIT license, zLib license, and the licenses derived from the BSD license.

This program is provided for general use, but WITHOUT ANY WARRANTY OF ANY KIND. This warranty disclaimer also extends to the implicit assurance of marketability or suitability of the program for a particular purpose.

More details can be found in the GNU General Public License. View the complete license texts here: www.sick.com/licensetexts. Printed copies of the license texts are also available on request.

