



RFU610

QUICKSTART en

1 About this document

The purpose of this Quickstart is to allow you to commission the RFU610-106xx RFID read/write device (UHF) quickly and easily and to achieve initial read results with transponders.

The Quickstart is valid for the regional variants listed in the "Device overview" section: [see Device overview, page 6](#).

The Quickstart describes the commissioning process for an application with an RFU610-106xx in an ambient temperature range of 0 °C to +50 °C.

Device variant RFU610-10600 (Ethernet variant, regional assignment: Europe) is used as the basis for the examples given, based on its default. The optional GL6 photoelectric sensor (1059241) is used as an example for the industrial-standard read-cycle triggering of the RFU610-106xx. The photoelectric sensor can be connected with the RFU610-106xx as a trigger sensor. Additional trigger sensors can be found at www.sick.com.

All rights reserved. Subject to change without notice.

2 Safety information

- This chapter is dedicated to the safety of commissioning personnel and the operator of the system in which the device is integrated.
- Read this Quickstart carefully before commissioning the device in order to familiarize yourself with the device and its functions. The Quickstart is considered a part of the device and must be kept in an accessible location in the immediate vicinity of the device at all times!
- For country-specific particulars to consider when operating the device, [see Operational restrictions, page 6](#).

⚠ WARNING

Health hazard as a result of high-frequency electromagnetic radiation!
The RFU610-10600 (region: Europe) is designed for operation in accordance with ETSI EN 302208. During operation, the human exposure regulations covered by EN 50364 must be observed.

- Limit human exposure to electromagnetic fields. Suitable safety distances must be maintained during both short-term and long-term work in the radiation range of the integrated antenna. Minimum distances to be maintained between the antenna and the human body during long-term transmission: 10 cm and maximum radiation power of the antenna of 100 mW (20 dBm) as per ETSI.

The RFU610-10601 (region: USA/Canada/Mexico) satisfies the limit values of the FCC for exposure to radiation in an uncontrolled environment.

- During operation, a safety distance of at least 20 cm must be maintained between the antenna and the human body.

- To comply with the IP67 enclosure rating in operation, the following requirements must be met. If these requirements are not met, the device does not fulfill any specified IP enclosure rating.
 - The side cover of the USB female connector and the microSD memory card slot must be screwed tight to the device.
 - The SICK cables plugged into the M12 and M8 connections must be screwed tight.
 - Any electrical connections that are not being used must be fitted with protective caps or plugs that are screwed tight (as in the delivery condition).
 - Only operate the device without a cover for a short period while inserting or removing the memory card or temporarily using the USB interface. During this time, protect the device against moisture and dust.

- The type label on the lower side of the device contains a pressure equalizing membrane. If damaged, water and dust leaks could occur.
- Opening the screws of the device housing will invalidate any warranty claims against SICK AG. For further warranty provisions, see the General Terms and Conditions of SICK AG, e.g., on the delivery note of the device.

📌 NOTE

SICK uses standard IP technology in its products. The emphasis is placed on availability of products and services.
SICK always assumes the following prerequisites:

- The customer ensures the integrity and confidentiality of the data and rights affected by its own use of the aforementioned products.
- In all cases, the customer implements the appropriate security measures, such as network separation, firewalls, virus protection, and patch management.

2.1 Intended use

The RFU610-106xx is an intelligent UHF read/write device from the RFU61x product family. The device is used for the automated, fixed identification of passive,

wireless-based data cards (transponders) on moving or stationary objects and their management.

As a compact read/write device, the RFU610-106xx has an internal antenna that is integrated into the housing. The device processes all standard passive transponders in accordance with ISO/IEC 18000-63 and EPCglobal UHF C1G2 in the regional UHF carrier frequency range. Thanks to its intelligent process logic, the device can be used either as a stand-alone solution or as part of a group in a network. The device sends the read results to a higher-level computer for further processing via its host interface. The device also receives commands for data card management (write, read, etc.) via this interface.

3 Device description

3.1 Device view

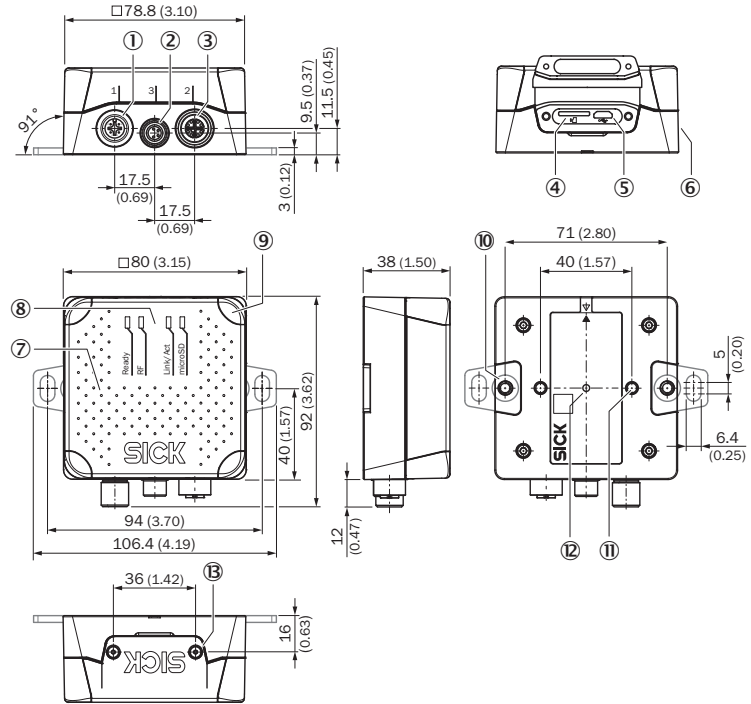
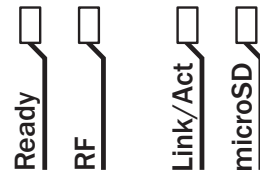

Figure 1: Dimensional drawing of the RFU610-106xx (all variants), unit: mm (inch), decimal separator: period

- ① Port 1: Power (male connector, M12, 4-pin, A-coded)
- ② Port 3: Trigger (female connector, M8, 4-pin, A-coded)
- ③ Port 2: PoE (female connector, M12, 8-pin, X-coded)
- ④ Slot for microSD memory card
- ⑤ "USB" connection (female connector, 5-pin, type Micro-B) interface for temporary use (service)
- ⑥ Side type label
- ⑦ Cover with integrated antenna
- ⑧ 4 x multi-colored LED (status)
- ⑨ 4 x RGB LED (process feedback)
- ⑩ 2 x M5 blind tapped holes, 6 mm deep for attaching the mounting straps
- ⑪ 2 x M5 blind tapped holes, 7 mm deep for mounting the device
- ⑫ Type label with integrated pressure compensation membrane
- ⑬ 2 x screw (M2,5 socket screw), captive, for side cover

3.2 Status displays



Status displays

Advertisement	LED	Color	Status
Ready	Lights up	Green	Device ready
	Lights up	Red	Hardware error
	Flashing	Green	Flashing cyclically 4 x red, 1 x green in PROFINET operation (single port): Trying to establish a connection to a PLC (IO controller) or loss of connection during operation
	Flashing	Red	
RF	Lights up	Green	UHF field activated
	Lights up	Red	Internal antenna fault / HF part
Link/Act	Lights up	Green	Data traffic via Ethernet
microSD	Lights up	Green	MicroSD memory card inserted and ready for operation. In this state, the device can either read data from the card or write data to the card. If the LED lights up, however, this does not indicate that the device is accessing the card!
	Lights up	Red	MicroSD memory card inserted; however, it cannot be read or is defective

Advertisement	LED	Color	Status
	Lights up	Yellow	OverSOPAS ET A function is started manually, which requires a memory card; however, the microSD memory card is not ready for operation (e.g., not plugged in, contacts contaminated, or without free storage space for writing).

3.3 microSD memory card (optional accessory)

The device can execute the following functions on the plug-in memory card:

- Automated, additional storage of the internal parameter set to an external storage medium (cloning function), if available. This is done in the framework of the recommended safety concept for the device parameter sets. The function is triggered by saving the internal parameter set with the "permanent" option. The function is used, among other things, to conveniently transfer the parameter set to a replacement device of the same type in the event of a fault.
- Continuous recording of diagnostic read data after the first manual start, e.g., via SOPAS ET. Recording is resumed after a device restart when the function is set permanently.

The first time a parameter set is stored, we recommend that an empty memory card is used (if necessary, check and delete the contents of the card on the PC using a card reader).

The memory card is not included with delivery.

Only use types approved by SICK to ensure reliable function of the memory card, see www.sick.com/RFU61x. The memory card has no write protection that can be activated.

Inserting the memory card

The card slot can be accessed on the device behind the plastic foil, see [Device description, page 1](#).

Maintaining enclosure rating IP67: see [Safety information, page 1](#).

- Switch off the supply voltage to the device.
- Loosen both screws on the cover.
- Carefully fold up the cover.
- Making sure it is in the correct position (with the contacts pointing to the front and down – see the symbol on the device), insert the memory card into the card slot until it locks into place.
- Screw the cover back on.
- Switch the supply voltage for the device back on.
- Once it is switched on, the device automatically detects the presence of a memory card and, depending on the card's content, behaves as follows:
 - If the card is empty or if it contains a parameter set that cannot be interpreted by the device, the device saves its currently valid internal parameter set to the card (provided there is sufficient storage space) and starts with the internal parameter set.
 - If the card contains a parameter set that can be interpreted by the device, the device overwrites the currently valid internal parameter set with this external parameter set. The goal is for the internal parameter set and the parameter set saved externally to always be identical.

NOTE

Possible data loss or irreparable damage to the memory card!

The device does not signal access to the card.

- Only use memory card when the device power is off.
- Do not remove the memory card or switch off the supply voltage while the SOPAS ET configuration software is making changes to the parameter values with the "permanent" option or starting functions in the device that access the memory card (e.g., logging data).
- To remove the memory card safely during operation, select the Remove card function under Analysis Tools/MicroSD memory card and wait for SOPAS ET to provide confirmation.

4 Mounting

4.1 Scope of delivery

- Device in the version ordered. Electrical connections fitted with protective caps or plugs. Without connecting cables. Without brackets.
- Regional printed Quickstarts: see [Device overview, page 6](#). Other language versions may be available in PDF format on the RFU610-106xx product page online at: www.sick.com/RFU61x.

4.2 Auxiliary equipment required

- 2 x M5 screws for mounting the device on a mounting device (bracket) supplied by the customer. Screw length is dependent on the mounting base (wall thickness of the bracket).
- When using an optional SICK bracket, the screws for mounting the device on the bracket are included in the scope of delivery of the bracket.

4.3 Installation requirements

- The permissible ambient conditions for operating the device must be observed, e.g., assigned region, ambient temperature, ground potential: see [Technical data \(excerpt\), page 5](#) and see [Electrical installation, page 2](#).
- The device must be mounted using the 2 M5 blind tapped holes provided, see [Device description, page 1](#).
- Stable mounting equipment with sufficient load-bearing capacity and appropriate dimensions for the device. Weight approx. 313 g (without cables), see [Device description, page 1](#).
- No electrically conductive material between transponder and device.

4.4 Mounting the device

- Select a suitable mounting location for the device. The mounting location and position depend on the antenna field of the device and the transponders used.
- Perform one of the following steps:
 - Mount the device on the bracket provided by the customer using the 2 screws. Screw the M5 screws no more than 7 mm deep into the blind tapped holes, see [Device description, page 1](#).
 - Mount the device on the SICK mounting accessories ordered separately.
- Align the surface of the internal antenna of the device (front face) to the data card on the object. While doing so, take into account the shape, alignment, and dimensions of the antenna fields. Avoid as far as possible any large metal surfaces positioned to the front. If this is not possible, do not mount the antenna plane parallel with the surface.

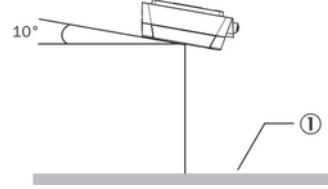

Figure 2: Selection of the approach angle with a large metal surface on the front. e.g., 10°

① Metal surface

- Ensure there is no electrically conductive material (e.g., metal or liquids) or persons between the device and the transponder during the write or read process. This will absorb or reflect the generated UHF field and thereby reduce the sensing range.

Sensing range of the reading and writing field

The UHF field of the internal antenna is influenced by its environment, making it impossible to provide a "clear" demarcation of the sensing range. Application-specific reflections can result in both overreaches and "holes". In addition to the read results, the RFU device can also output diagnostic data that provide an indication of the write and read quality. This data can be used to achieve optimum read results when setting up the system.

The quality of the transponder and the material of the object also determine the sensing range. The quality of the transponder is determined by the antenna gain, the integrated transponder chip and the related sensitivity, and the reflected energy.

The radiation pattern shown here for the internal antenna of the device was obtained in a reproducible environment (absorber chamber) for illustrative purposes. It may therefore only have limited applicability to your specific application.

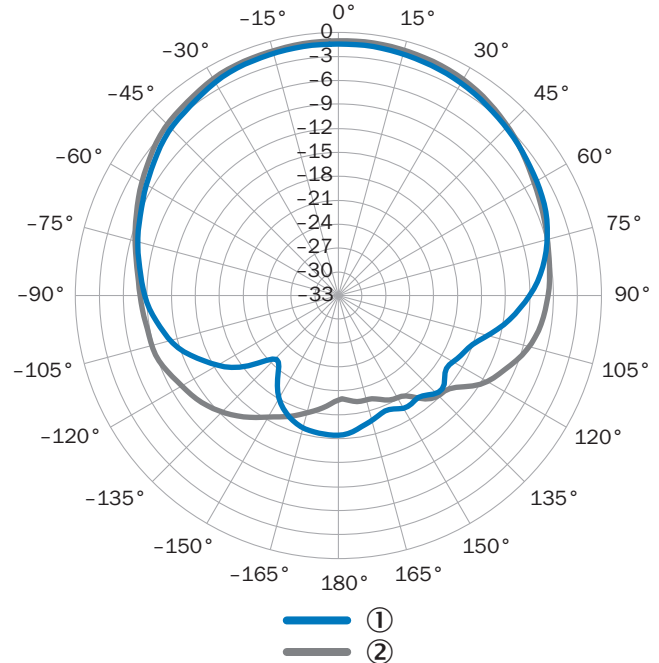

Figure 3: Measured antenna gain in dBi at 866.5 MHz, LHCP (left-hand circularly polarized)

- ① Azimuth plane (horizontal)
- ② Elevation plane (vertical)

5 Electrical installation

- The electrical installation must only be performed by electrically qualified persons.
- Standard safety requirements must be observed when working on electrical systems!
- Only connect and disconnect electrical connections for the device when the power is off. Otherwise, there is a risk of damaging the devices.
- When using connecting or extension cables with an open end, make sure that bare wire ends are not touching (risk of short-circuit when the supply voltage is switched on). Wires must be appropriately insulated from each other.
- Wire cross-sections in the supply cable from the user's power system must be designed in accordance with the applicable national standards.

- Connect the device to the permissible supply voltage only, [see Technical data \(excerpt\), page 5](#).
- Protect the device with a separate fuse of 0.8 A (slow blowing) at the start of the supply circuit.
- All circuits connected to the device must be designed as ES1 circuits. The voltage supply or power supply unit must satisfy ES1 requirements in accordance with the currently applicable EN 62368-1.

⚠ WARNING

Risk of injury and damage caused by electrical current!

The device is designed for operation in a system with proficient grounding of all connected devices and mounting surfaces to the same ground potential. Due to equipotential bonding currents between the device and other grounded devices in the system, incorrect grounding of the device can charge the metal housing to a dangerous voltage, cause malfunction and destruction of devices as well as damage to the cable shielding through heating, and thus cause cable fires.

- Ensure that the ground potential is the same at all grounding points.
- If the cable insulation is damaged, disconnect the voltage supply immediately and have the damage repaired.

! NOTICE

Risk of damage to the device due to possible short-circuit!

The supply voltage input for the device is designed with internal circuit protection to provide reverse polarity protection. The internal functional earth, which also corresponds to the negative pole of the supply voltage for the device, is connected directly to the metal housing of the device due to reasons relating to high frequency.

If the supply voltage is polarity-reversed, this will not cause any damage provided that the following conditions are met for the device:

The device is not connected in an electrically conductive manner, either via other cables or via its housing, to other peripheral devices which use the same reference potential.

5.1 Connecting the device electrically

! NOTE

The USB interface of the device is used in industrial environments only as a service interface for temporary use (e.g. for configuration, troubleshooting). Permanent use in real operation of the system as a host interface is not intended.

Voltage supply

There are two ways to supply the device with voltage, as follows:

1. Power and Ethernet: DC 18 V ... 30 V
 - Port 1: Power (24 V)
 - Port 2: Ethernet
2. Power over Ethernet (PoE): DC 48 V / 57 V As per PoE technology
 - Port 1: Not assigned
 - Port 2: PoE

! NOTE

The voltage supply via a power supply unit must be capable of bridging a brief power failure of 20 ms.

It is possible to connect both variants at the same time; however, it is recommended to select just one variant.

Connecting connection variants at the same time

Initial situation	Adjustment	Effect
Voltage supply power via port 1	PoE via port 2 also connected.	No effect on the device status.
Voltage supply PoE via port 2	Power via port 1 also connected.	No effect on the device status. Voltage supply with immediate effect via power via port 1 (dominant).
Voltage supply power via port 1 (dominant) and PoE via port 2	Power via port 1 connection is isolated.	Device restarts. Voltage supply with immediate effect via PoE via port 2.

After successful initialization, the Ready LED illuminates green.

Trigger

Read and write commands for the device can be started and ended using a trigger sensor. Trigger sensors can be connected directly to the device (port 3). The permanently active supply voltage is received by the trigger sensor from the device. Cover the male connectors with protective caps or male connectors when port 3 is not in use. For additional information, [see Technical data \(excerpt\), page 5](#).

Port 3: Trigger

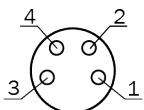

Figure 4: Female connector, 4-pin, A-coded

Pin assignment of the "Trigger" connection

Pin	Signal	Function
1	V_{Trigger}	Trigger supply voltage

Pin	Signal	Function
2	NC	NC
3	GND	Ground
4	Sensor 1	Digital input

5.1.1 RFU610-106xx: Power and Ethernet

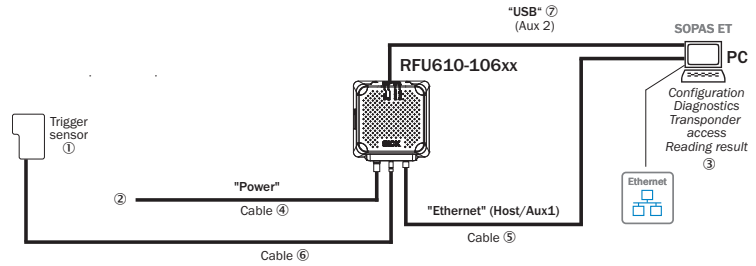

Figure 5: Commissioning: Electrical connection block diagram of the RFU610-106xx

- ① Trigger sensor (read cycle)
- ② Supply voltage V_s
- ③ Configuration, diagnosis, transponder access or display of read results
- ④ Power adapter cable (female connector, M12, 4-pin, A-coded/open ends)
- ⑤ Ethernet adapter cable (male connector, M12, 8-pin, X-coded/male connector, RJ-45, 8-pin)
- ⑥ Trigger adapter cable (male connector, M8, 4-pin, A-coded/female connector, M8, 4-pin, A-coded)
- ⑦ Adapter cable (male connector, 5-pin, USB, Micro-B type/male connector, 4-pin, USB, type A)

1. Connect port 1 directly to a supply voltage via a power adapter cable (e.g., 2095607).
2. Connect port 2 directly to a PC via an Ethernet adapter cable (e.g., 6049728).
3. Connect the trigger sensor (e.g., GL6 (1059241)) directly to port 3 of the device via a trigger adapter cable (e.g., 2096347).

Port 1: Power

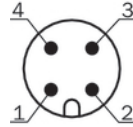

Figure 6: Male connector, M12, 4-pin, A-coded

Pin assignment of the "Power" connection (M12)

Pin	Signal	Function
1	V_s	Supply voltage
2	NC	NC
3	GND	Ground
4	NC	NC

Port 2: Ethernet

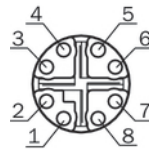

Figure 7: Female connector, M12, 8-pin, X-coded

Pin assignment of the "Ethernet" connection

Pin	Signal	Function
1	TD+	Sender+
2	TD-	Sender-
3	RD+	Receiver+
4	RD-	Receiver-
5	PoE-	Supply voltage-
6	PoE-	Supply voltage-
7	PoE+	Supply voltage+
8	PoE+	Supply voltage+

5.1.2 RFU610-106xx: Power over Ethernet (PoE)

RFU610-106xx (PoE connection)

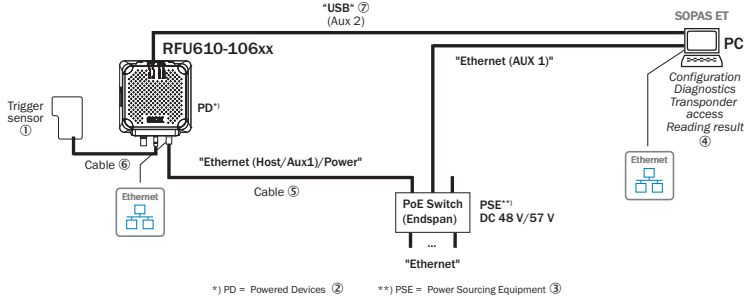

Figure 8: Commissioning: Electrical connection block diagram of the RFU610-106xx

- ① Trigger sensor (read cycle)
 - ② PD = Energy consumer
 - ③ PSE = Energy source
 - ④ Configuration, diagnosis, transponder access or display of read results
 - ⑤ PoE adapter cable (male connector, M12, 8-pin, X-coded/male connector, RJ-45, 8-pin)
 - ⑥ Trigger adapter cable (male connector, M8, 4-pin, A-coded/female connector, M8, 4-pin, A-coded)
 - ⑦ Adapter cable (male connector, 5-pin, USB, Micro-B type/male connector, 4-pin, USB, type A)
1. Connect port 2 directly to a PoE switch or PoE injector via a PoE adapter cable (e.g., 6049728).
 2. Connect the trigger sensor (e.g., GL6 (1059241)) directly to port 3 of the device via a trigger adapter cable (e.g., 2096347).

Port 2: PoE

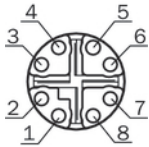

Figure 9: Female connector, M12, 8-pin, X-coded

Pin assignment of the "PoE" connection

Pin	Signal	Function
1	TD+	Sender+
2	TD-	Sender-
3	RD+	Receiver+
4	RD-	Receiver-
5	PoE-	Supply voltage-
6	PoE-	Supply voltage-
7	PoE+	Supply voltage+
8	PoE+	Supply voltage+

6 Commissioning and configuration with PC (Windows)

Adjustment of the device parameters to the application as well as diagnostics in the event of malfunctions is undertaken by default with the SOPAS ET configuration software.

6.1 Installing and starting the configuration software

1. Download and install the latest version of the SOPAS ET configuration software as well as the current device description files (*.sdd): www.sick.com/SOPAS_ET. In this case, select the "Complete" option as suggested by the installation wizard. Administrator rights may be required on the PC to install the software.
2. Start the "SOPAS ET" program option after completing the installation. Path: Start > Programs > SICK > SOPAS ET Engineering Tool > SOPAS.
3. Establish communication between SOPAS ET and device with the automatically launching wizard. To do so, select the RFU610-106xx under the devices available depending on the connected communication interface, e.g. in the Ethernet (default Ethernet address: IP address: 192.168.0.1, subnet mask: 255.255.255.0). SOPAS ET establishes communication with the device and loads the associated device description file. The **Quickstart** tab opens.

6.2 Detecting a transponder in Quickstart mode

1. Bring one or more standards-compliant UHF transponders into the working range of the internal antenna of the device. The UII/EPC of the individual transponders must be differentiated so that several transponders can be detected.
2. Click the **Start** button on the **Quickstart** tab of SOPAS ET. SOPAS ET generates an automated read cycle and lists the detected transponders one after another in the Quickstart window.

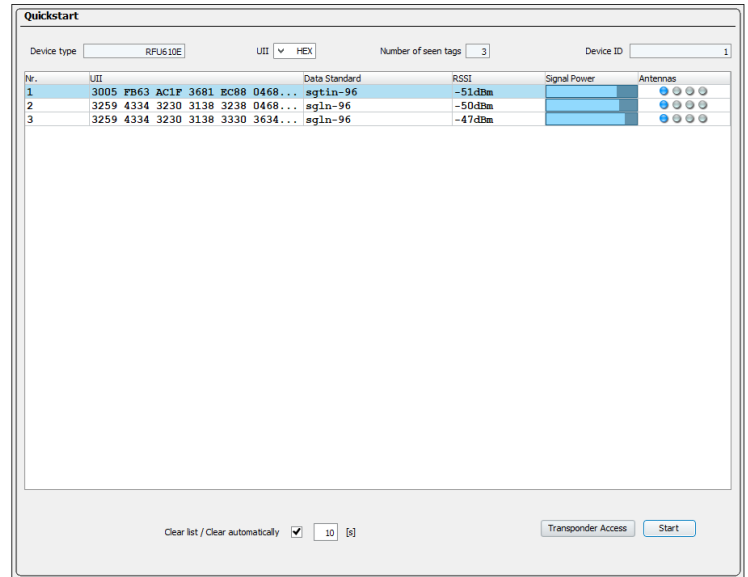

Figure 10: SOPAS ET display of the detected transponders in the Quickstart window

Feedback about transponder detection in the UHF field

In Quickstart mode, the default signals of the process feedback LEDs indicate whether a UHF field is present and transponders have been detected. The process feedback LEDs are located in the four corners of the antenna cover and light up blue in this case. The option is available to choose between two brightness levels in SOPAS ET to adjust the brightness of the process feedback LEDs.

Process feedback LEDs

LED status	Status
Lit up (permanently)	0 transponders in field
Flashing slowly (f = 1.25 Hz)	1 transponder in field
Flashing quickly (f = 2.5 Hz)	2 transponders in field
Flashing faster (f = 5 Hz)	More than 2 transponders in field

NOTE

The automated triggering in Quickstart mode is intended for (initial) commissioning and not for permanent use when operating the device under real conditions.

6.3 Accessing the data on a transponder

1. In order to access the memory area of a transponder, click the **Stop** button in **Quickstart**.
2. Highlight the desired transponder (click it with the mouse).
3. Click the **Transponder Access** button. The **Transponder Management Access** tab displays the content of the selected transponder.

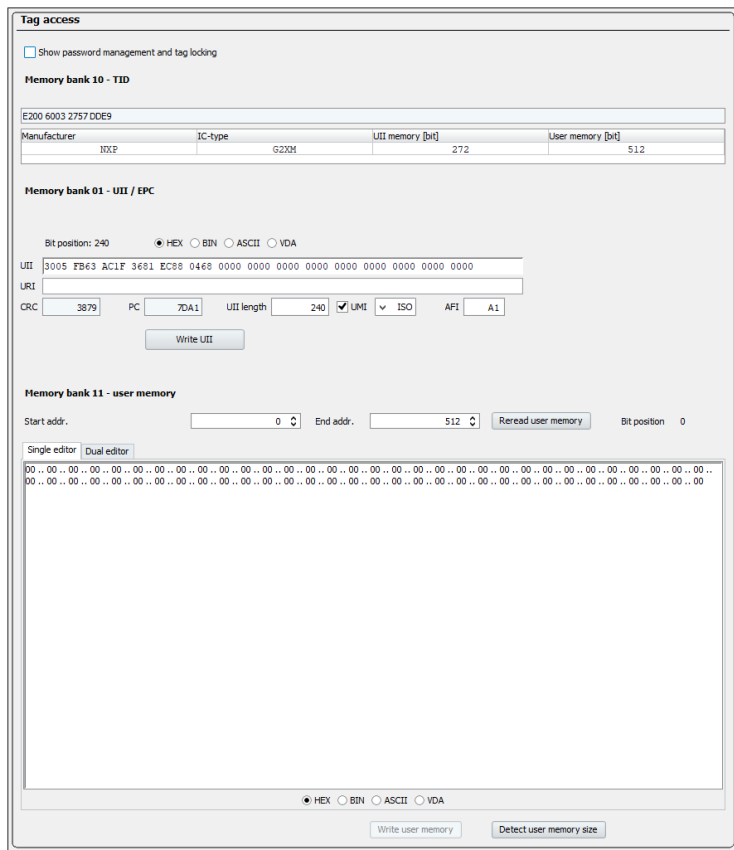

Figure 11: Transponder Access SOPAS ET display window

NOTE
The TID (tag identifier) of the transponder cannot be changed.

6.4 Continuing the configuration

- Under SOPAS ET in the left-hand navigation tree, edit the required tabs for the application using the additional entries under **Parameters**. These include: u. a. antenna configuration, performance optimization, data pre-processing, transponder processing, object trigger control (e.g., Via "Sensor 1" switching input), data processing and output, data output interface(s), function of the digital input and the possible use of an optional microSD memory card.
- Set the transmitting power for the internal antenna using sliders on the **Antenna Configuration** tab.
 - Regional permissible values for the antenna, see [Device overview, page 6](#).
 - Transmitting power default RFU610-106xx: 10 dBm (10 mW)

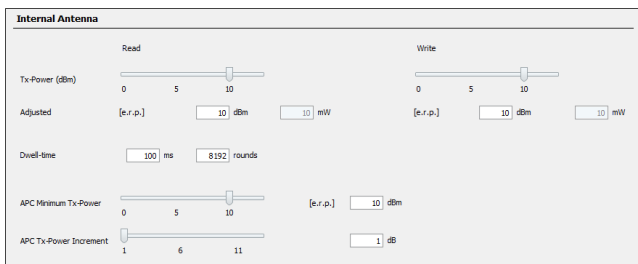



Figure 12: SOPAS ET: Example setting for the internal antenna

- Test and, if necessary, modify the settings made when operating the system under real conditions.

6.5 Completing the configuration

- Permanently save the entire configuration once it has been successfully tested:
 - Parameter set in the device: Click the button .
 - Configuration file on the PC: Click buttons **Device > Export SDV file**.

7 Maintenance and care

The device does not contain any components that require maintenance.

- To maintain the full read and write rate, gently clean the antenna hood (plastic) in case of soiling (e.g. metal dust) with a soft, damp cloth (mild cleaning agent).

8 Transport and storage

Transport and store the device in the original packaging, with protective plugs and caps completely screwed-on. Do not store outdoors. To ensure that any residual moisture present can escape, do not store the device in airtight containers. Do not expose to any aggressive substances.

Storage conditions: Dry, dust-free, no direct sunlight, as little vibration as possible, storage temperature -40 °C to +70 °C, relative humidity max. 90% (non-condensing).

9 Repairs

Repair work on the device may only be performed by qualified and authorized service personnel from SICK AG.

10 Disassembly and disposal

Any device which can no longer be used must be disposed of in an environmentally friendly manner in accordance with the applicable country-specific waste disposal regulations. As it is categorized as electronic waste, the device must never be disposed of with household waste!

11 Technical data (excerpt)

Technical data

Type	RFU610-106xx
Regional assignment	Depending on type: see Device overview, page 6
Firmware version	Depending on type: see Device overview, page 6
Carrier frequency	Depending on type: see Device overview, page 6
Transmitting power	Depending on type: see Device overview, page 6
Internal antenna	<ul style="list-style-type: none"> Circularly polarized Axial ratio: 2 dB Aperture angle: 110° Front-to-back ratio: > 5 dB
Air interface protocol	ISO/IEC 18000-6C EPCglobal UHF Class 1 Generation 2
Scanning range	0.5 m (depending on the transponder and ambient conditions)
USB ²⁾	AUX 2 (USB 2.0) for servicing
Ethernet	10/100 Mbit/s <ul style="list-style-type: none"> Host 1 (TCP/IP, EtherNet/IP, PROFINET Single Port) for data output AUX 1 (TCP/IP) for servicing ¹⁾ Services: DHCP, NTP, HTTP
Digital input	1 x physical, trigger sensors can be connected directly to the device (port 3) – max. 40 mA
Electrical connections	<ul style="list-style-type: none"> Port 1: 1 x male connector, M12, 4-pin, A-coded Port 2: 1 x female connector, M12, 8-pin, X-coded Port 3: 1 x female connector, M8, 4-pin, A-coded USB: 1 x female connector, 5-pin, Micro-B type
Optical indicators	<ul style="list-style-type: none"> 4 x multi-colored LED (status) 4 x RGB LED (process feedback)
Parameter backup (cloning)	Optional: By inserting a microSD memory card
Supply voltage V _s	ES1 and PS1 as per EN 62368-1, NEC protection class 2 (UL1310) <ul style="list-style-type: none"> Power and Ethernet: DC 18 V ... 30 V PoE: DC 48 V / 57 V As per PoE technology
Power consumption	Operation <ul style="list-style-type: none"> Typical 6 W Readiness (standby) <ul style="list-style-type: none"> Typical 3 W
Housing / Weight	Aluminum/approx. 313 g
Safety	EN 62368-1: 2014
Electrical protection class	III (EN 61140: 2006-08)
Enclosure rating	After EN 60529: 1991-10 / A2: 2000-02 <ul style="list-style-type: none"> IP67
Radio equipment approval	See radio equipment approvals on the product page at: www.sick.com/RFU61x in the Downloads/Certificates tab.
EMC	EN 301489-3
MTBF	22 years (50 °C)
Vibration resistance	IEC 60068-2-6: 2007 (10 ... 150 Hz/ 5 g Sinus)
Shock resistance	IEC 60068-2-27: 2008 (30 g/ 6 ms/ 12 impacts per axis/half sinus 25 g/ 6 ms/ 200 impacts per axis/half sinus)
Vibration resistance	IEC 60068-2-64: 2008 (10 ... 500 Hz/ 3.5 g RMS)
Ambient temperature range	<ul style="list-style-type: none"> Operation: -25 °C ... +50 °C Storage: -40 °C ... +70 °C
Relative humidity	0% ... 90% Non-condensing
Conformity	CE, UL ³⁾
Clock	NTP network time protocol, no internal clock

1) For example: configuration, diagnosis, transponder access or display of the read results.
2) Interface only for temporary use
3) Only UL certified if the type label contains the UL logo.

For further technical specifications, see the online data sheet on the product page at: www.sick.com/RFU61x

Regulatory notes

Europe: Simplified EU declaration of conformity

SICK AG hereby declares that the RFU610-106xx radio equipment complies with the 2014/53/EU directive. The complete text of the EU declaration of conformity is available at the following web address: www.sick.com/RFU61x.

12 Device overview

RFU610-106xx: Device overview

Regional assignment	Firmware version	Carrier frequency	Transmitting power of the internal antenna	Device type	Part no.	Supplied Quickstart (Part no.)
Europe	V2.06	865.7 MHz ... 867.5 MHz	Max. 24 mW (ERP ¹⁾)	RFU610-10600	1091102	English (8023832), German (8024099)
USA/Canada	V2.06	902.75 MHz ... 927.25 MHz	Max. 42 mW (EIRP ²⁾)	RFU610-10601	1099890	English (8023832)

1) ERP = equivalent radiated power.

2) EIRP = equivalent isotropic radiated power.

12.1 Operational restrictions

! NOTICE

Operational restrictions!

When delivered, the frequency band of the RFU610-106xx is configured in such a way that it can be operated in the following assigned regions (depending on the model) without interfering with protected frequencies (such as mobile communications):

- RFU610-10600 (Europe)
- RFU610-10601 (USA/Canada)

Operating the same RFU610-106xx in other regions can interfere with protected frequencies.

- Only use the RFU610-106xx in the region for which it has been approved.
- When reselling the RFU610-106xx, inform the buyer of the regional assignment.

France

The RFU610-106xx must not be operated within a 20 km radius of 13 military zones.

Lithuania

There may be restrictions in Lithuania (extent not currently known).

USA

(1) This device complies with part 15 of the FCC Rules. Operation is subject to the following two conditions:

(1) This device may not cause harmful interference, and (2) this device must accept any interference received, including interference that may cause undesired operation.

(2) Changes or modifications not expressly approved by the party responsible for compliance could void the user's authority to operate the equipment.

(3) Note: This equipment has been tested and found to comply with the limits for a Class A digital device, pursuant to part 15 of the FCC Rules. These limits are designed to provide reasonable protection against harmful interference when the equipment is operated in a commercial environment. This equipment generates, uses, and can radiate radio frequency energy and, if not installed and used in accordance with the instruction manual, may cause harmful interference to radio communications. Operation of this equipment in a residential area is likely to cause harmful interference in which case the user will be required to correct the interference at his own expense.

(4) To comply with FCC part 15 rules in the United States, the system must be professionally installed to ensure compliance with the Part 15 certification.

(5) It is the responsibility of the operator and professional installer to ensure that only certified systems are deployed in the United States. The use of the system in any other combination (such as co-located antennas transmitting the same information) is expressly forbidden.

(6) This device complies with the limit values defined by the FCC for radio radiation in an uncontrolled environment. The device must have a minimum distance of 20 cm between the source of radiation and your body.

Canada

(1) This Class A digital apparatus complies with Canadian ICES-003.

(2) This device satisfies the Industry Canada CNR applicable to license-free radio equipment. Use is permitted providing the two following conditions are met: (1) The device must not cause any faults and (2) the user of the device must accept any fault produced in the device, even if this may impair its function.

13 Sources for obtaining more information

Additional information about the device, its optional accessories, and fieldbus modules can be found in electronic format on the following product pages on the Internet at:

13.1 RFU610-106xx read/write device

www.sick.com/RFU61x

- Summary of type-specific technical data (online data sheet)
- EU declaration of conformity
- Dimensional drawing and 3D CAD dimension models in various electronic formats
- Suitable accessories (including a. transponders, cables, brackets, trigger sensors)
- Quickstart RFU610-106xx read/write device (UHF) in English (no. 8023832) and German (no. 8024099) as well as in other languages

- Ordering information, e.g. in the RFID Product Information in English (no. 8016267) and German (no. 8016266)
- Publications dealing with accessories

13.2 Function blocks

www.sick.com/RFU61x

- Function blocks for communication between a SIMATIC controller (S7-300/S7-400) and the device.
- Function blocks for other controllers on request.

13.3 Documents on request

- Overview of command strings of the device

Support is also available from your sales partner: www.sick.com

13.4 Copyright notices

Open source programs

SICK uses open-source software in the device. This software is licensed by the rights holders using the following licenses among others: the free licenses GNU General Public License (GPL Version2, GPL Version3) and GNU Lesser General Public License (LGPL), the MIT license, zLib license, and the licenses derived from the BSD license.

This program is provided for general use, but WITHOUT ANY WARRANTY OF ANY KIND. This warranty disclaimer also extends to the implicit assurance of marketability or suitability of the program for a particular purpose.

More details can be found in the GNU General Public License.

View the complete license texts here: www.sick.com/licenses texts

Printed copies of the license texts are also available on request.