

Test Report

Report Number:

F181673E3

Equipment under Test (EUT):

RFU610-10601

Applicant:

Sick AG

Manufacturer:

Sick AG



Deutsche
Akkreditierungsstelle
D-PL-17186-01-01
D-PL-17186-01-02
D-PL-17186-01-03



References

- [1] **ANSI C63.10-2013**, American National Standard of Procedures for Compliance Testing of Unlicensed Wireless Devices
- [2] **FCC CFR 47 Part 15**, Radio Frequency Devices
- [3] **RSS-247 Issue 2 (February 2017)**, Digital Transmission Systems (DTSs), Frequency Hopping Systems (FHSs) and Licence-Exempt Local Area Network (LE-LAN) Devices
- [4] **RSS-Gen Issue 5 (April 2018)**, General Requirements for Compliance of Radio Apparatus

TEST RESULT

The requirements of the tests performed as shown in the overview (clause 4) were fulfilled by the equipment under test.

The complete test results are presented in the following.

Test engineer:	Thomas KÜHN		18.03.2019
	Name	Signature	Date
Authorized reviewer:	Michael DINTER		18.03.2019
	Name	Signature	Date

This test report is only valid in its original form.

Any reproduction of its contents in extracts without written permission of the accredited test laboratory PHOENIX TESTLAB GmbH is prohibited.

The test results herein refer only to the tested sample. PHOENIX TESTLAB GmbH is not responsible for any generalisations or conclusions drawn from these test results concerning further samples. Any modification of the tested samples is prohibited and leads to the invalidity of this test report. Each page necessarily contains the PHOENIX TESTLAB Logo and the TEST REPORT NUMBER.

Contents:	Page
1 Identification.....	4
1.1 Applicant.....	4
1.2 Manufacturer.....	4
1.3 Test laboratory.....	4
1.4 Technical data of equipment.....	5
1.5 Dates.....	6
2 Operational states.....	6
3 Additional information.....	7
4 Overview.....	7
5 Test results.....	8
5.1 Bandwidth.....	8
5.1.1 Method of measurement (bandwidth).....	8
5.1.2 Test results (20 dB bandwidth).....	9
5.1.3 Test results (99 % bandwidth).....	11
5.2 Carrier frequency separation.....	13
5.2.1 Method of measurement (carrier frequency separation).....	13
5.2.2 Test results (carrier frequency separation).....	14
5.3 Number of hopping frequencies.....	16
5.3.1 Method of measurement (number of hopping frequencies).....	16
5.3.2 Test results (number of hopping frequencies).....	17
5.4 Dwell time.....	18
5.4.1 Method of measurement (dwell time).....	18
5.4.2 Test results (dwell time).....	19
5.5 Maximum peak output power.....	21
5.5.1 Method of measurement (maximum peak output power).....	21
5.5.2 Test results (maximum peak output power).....	21
5.6 Radiated emissions.....	22
5.6.1 Method of measurement (radiated emissions).....	22
5.6.2 Test results (radiated emissions).....	29
5.6.2.1 Preliminary radiated emission measurement (10 MHz to 10 GHz).....	29
5.6.2.2 Final radiated emission measurement (10 MHz to 30 MHz).....	34
5.6.2.3 Final radiated emission measurement (30 MHz to 1 GHz).....	34
5.6.2.4 Final radiated emission measurement (1 GHz to 10 GHz).....	36
5.7 Conducted emissions on power supply lines (150 kHz to 30 MHz).....	38
5.7.1 Method of measurement.....	38
5.7.2 Test results (conducted emissions on power supply lines).....	39
6 Test equipment and ancillaries used for tests.....	41
7 Test site Validation.....	42
8 Report history.....	42
9 List of annexes.....	42

1 Identification

1.1 Applicant

Name:	SICK AG
Address:	Merkurring 20 22143 Hamburg
Country:	Germany
Name for contact purposes:	Mr. Christian MÜNTER
Phone:	+49 40 61 16 80 - 243
Fax:	+49 40 61 16 80 - 201
eMail address:	Christian.Muenter@sick.de
Applicant represented during the test by the following person:	-

1.2 Manufacturer

Name:	SICK AG
Address:	Merkurring 20 22143 Hamburg
Country:	Germany
Name for contact purposes:	Mr. Christian MÜNTER
Phone:	+49 40 61 16 80 - 243
Fax:	+49 40 61 16 80 - 201
eMail address:	Christian.Muenter@sick.de
Manufacturer represented during the test by the following person:	-

1.3 Test laboratory

The tests were carried out at: **PHOENIX TESTLAB GmbH**
Königswinkel 10
32825 Blomberg
Germany

Accredited by Deutsche Akkreditierungsstelle GmbH (DAkKS) in compliance with DIN EN ISO/IEC 17025 under Reg. No. D-PL-17186-01-02 and D-PL-17186-01-05, FCC Test Firm Designation Number DE0004, FCC Test Firm Registration Number 469623, CAB Identifier DE0003 and ISED# 3469A.

EUT (Equipment Under Test)

Test object: *	UHF RFID read/write device
Model name / HVIN: *	RFU610-10601
PMN: *	RFU610
FCC ID:*	WRMRFU610
IC: *	10066A-RFU610
Serial number: *	19099024
PCB identifier: *	EK-Frontend 2104880/EK-Digital 2100953/EK-Koppler FCC 2100952
Hardware version: *	Prototype
Software version / FVIN: *	T2.06RC03
Lowest internal frequency: *	18.432 MHz

* declared by the applicant.

Note: PHOENIX TESTLAB GmbH does not take samples. The samples used for tests are provided exclusively by the applicant.

1.4 Technical data of equipment

Channel 1	RX:	902.75 MHz	TX:	902.75 MHz
Channel 25	RX:	914.75 MHz	TX:	914.75 MHz
Channel 50	RX:	927.25 MHz	TX:	927.25 MHz

Rated RF output power: *	20 dBm (conducted)				
Antenna type: *	Internal				
Antenna gain: *	-4.5 dBi				
Antenna connector: *	Yes (internal only)				
Adaptive frequency agility: *	Yes				
Modulation: *	FHSS (PR-ASK / DSB-ASK)				
Supply Voltage (DC-Port): *	U _{nom} =	24.0 V DC	U _{min} =	16.0 V DC	U _{max} = 30.0 V DC
Supply Voltage (PoE): *	U _{nom} =	48.0 V DC	U _{min} =	36.0 V DC	U _{max} = 57.0 V DC
Temperature range: *	-25 °C to +50 °C				
Ancillary used for test:	None				

* declared by the applicant.

Identification	Connector		Length *
	EUT	Ancillary	
Ethernet	8-pin M12-connector	RJ45	2.0 m
DC-Power-Port	4-pin M12-connector	-	2.0 m
Digital I/O	4-pin M8-connector	4-pin M8-connector	2.0 m

*: Length during the test if no other specified.

1.5 Dates

Date of receipt of test sample:	06.03.2019
Start of test:	07.03.2019
End of test:	18.03.2019

2 Operational states

All tests were carried out with an unmodified sample with integral antenna.

During all tests the RFU610-10600 was powered by an external power supply with 24.0 V DC.

Because the EUT has no normal position defined, the measurements inside the fully anechoic chamber were carried out with the EUT mounted on a 3-D positioner; the final measurements on the open area test site were carried out in three orthogonal directions. These were defined as follows:

- Pos. 1: EUT lying on the table, LEDs showing upwards.
- Pos. 2: EUT standing on the table standing, cables showing sideward.
- Pos. 3: EUT standing on the table standing, cables showing downwards.

For details of these positions refer also the photographs in annex A of this test report.

The operation mode could be chosen with the help of a laptop computer with a test-software, communicates with the EUT via the Ethernet line.

For all measurements the output power of the EUT was set to 20 dBm. As declared by the applicant that the antenna has a gain of -4.5 dB.

The following test modes were adjusted during the tests:

Test items	Operation	Operation mode
20 dB bandwidth	Transmit with normal modulation on channel 1, 25 or 50	1, 2, 3
Carrier frequency separation	Transmit with normal modulation on channel 1, 25 or 50	1, 2, 3
Number of hopping channels	Transmit with normal modulation, hopping on all channels	4
Dwell time	Transmit with normal modulation on channel 25	2
Maximum peak output power	Transmit with normal modulation on channel 1, 25 or 50	1, 2, 3
Radiated emissions (transmitter)	Transmit with normal modulation on channel 1, 25 or 50	1, 2, 3
Conducted emissions on supply line	Transmit with normal modulation on channel 25	2

Physical boundary of the EUT

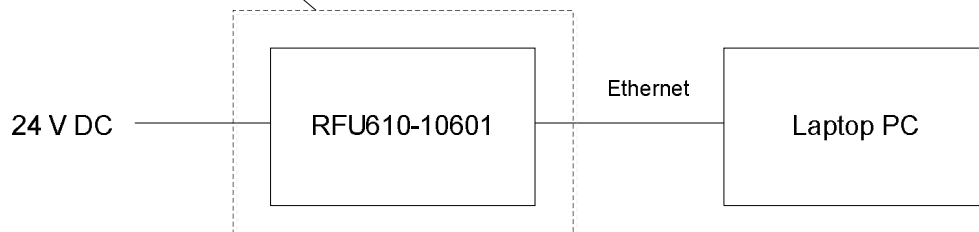

3 Additional information

This test report documents the results of the measurements of the intentional radiator part of the EUT. The results of the digital part of the EUT were documented under PHOENIX TESTLAB GmbH test report reference F181673E4.

During the tests the EUT was not labelled as required by FCC / IC.

4 Overview

Application	Frequency range [MHz]	FCC 47 CFR Part 15 section [2]	RSS 247 [3] or RSS-Gen [4]	Status	Refer page
20 dB bandwidth	General	15.247 (a) (1) (i)	5.1 (c) [3]	Passed	8 et seq.
99 % bandwidth	General	-	6.7 [4]	Passed	8 et seq.
Carrier frequency separation	General	15.247 (a) (1) (i)	5.1 (b) [3]	Passed	11 et seq.
Number of hopping channels	902.0 – 928.0	15.247 (a) (1) (i)	5.1 (c) [3]	Passed	16 et seq.
Dwell time	902.0 – 928.0	15.247 (a) (1) (i)	5.1 (c) [3]	Passed	18 et seq.
Maximum peak output power	902.0 – 928.0	15.247 (b) (2)	5.4 (a) [3]	Passed	21 et seq.
Radiated emissions (transmitter)	10 - 10,000	15.247 (d) 15.205 (a) 15.209 (a)	5.5 [3] 8.9 [4]	Passed	22 et seq.
Conducted emissions on supply line	0.15 - 30	15.207 (a)	8.8 [4]	Passed	38 et seq.
Antenna requirement	-	15.203 [2]	6.8 [4]	Passed*	-

*: Integrated antenna only, requirement fulfilled.

5 Test results

5.1 Bandwidth

5.1.1 Method of measurement (bandwidth)

The calibration of the spectrum analyser has to be checked with the help of a known signal from a signal generator. The EUT has to be connected to the spectrum analyser via a low loss cable. If the EUT is not equipped with an antenna connector, a temporary antenna connector has to be installed. The EUT has to be switched on and the hopping function has to be disenabled, the transmitter shall work with its maximum data rate.

20 dB bandwidth

The following spectrum analyser settings according to [1] shall be used:

- Span: App. 2 to 5 times the 20 dB bandwidth, centered on the actual hopping channel.
- Resolution bandwidth: 1 % to 5 % of the 20 dB bandwidth.
- Video bandwidth: three times the resolution bandwidth.
- Set the reference level of the instrument as required, keeping the signal from exceeding the maximum input mixer level for linear operation. In general, the peak of the spectral envelope shall be more than [10 log (OBW/RBW)] below the reference level.
- Sweep: Auto.
- Detector function: peak.
- Trace mode: Max hold.

After trace stabilisation the marker shall be set on the signal peak. The first display line has to be set on this value. The second display line has to be set 20 dB below the first line (or the peak marker). The frequency lines shall be set on the intersection points between the second display line and the measured curve.

99 % bandwidth:

The following spectrum analyser settings shall be used:

- Span: wide enough to capture all emission scirts.
- Resolution bandwidth: 1 to 5 % of the OBW.
- Video bandwidth: App. three times the RBW.
- Sweep: Auto.
- Detector function: Peak.
- Trace mode: Max hold.

After trace stabilisation the marker shall be set on the signal peak. Use the 99 % bandwidth functionality of the spectrum analyser to integrate the requested bandwidth.

The measurement will be performed at the upper, the lower end and the middle of the assigned frequency band.

Test set-up:

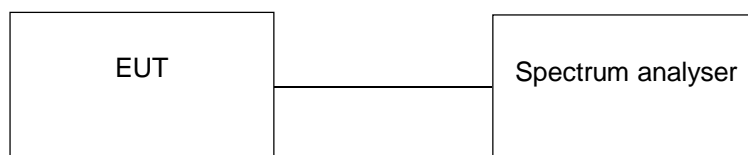

5.1.2 Test results (20 dB bandwidth)

Ambient temperature	22 °C	Relative humidity	33 %
---------------------	-------	-------------------	------

181673 101.wmf: 20 dB bandwidth at the lower end of the assigned frequency band:

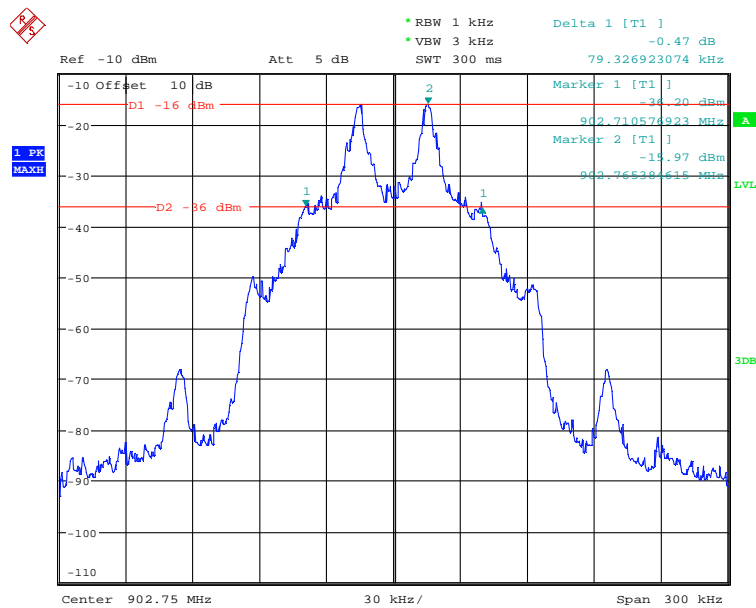

181673 102.wmf: 20 dB bandwidth at the middle of the assigned frequency band:

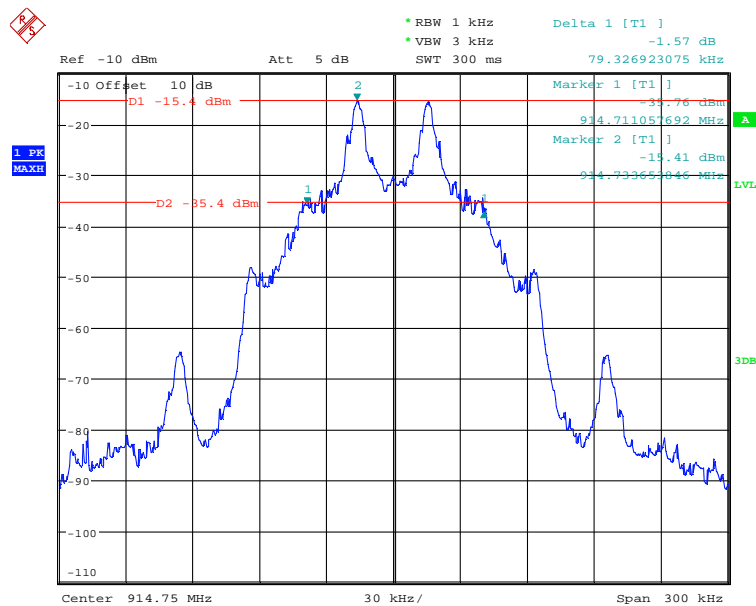

181673_103.wmf: 20 dB bandwidth at the upper end of the assigned frequency band:

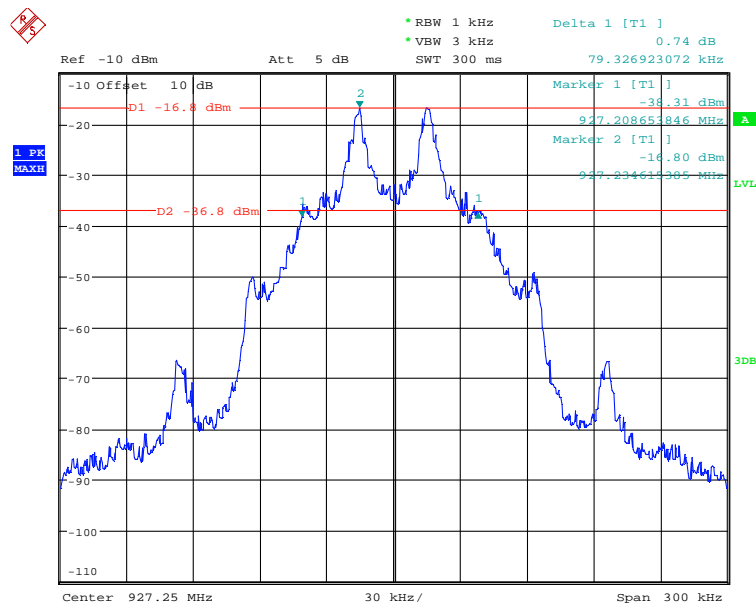

Channel number	Channel frequency [MHz]	20 dB bandwidth [kHz]
1	902.750	79.327 kHz
25	914.750	79.327 kHz
50	927.250	79.327 kHz
Measurement uncertainty		+0.66 dB / -0.72 dB

Test equipment used (see clause 6):

1 - 3

5.1.3 Test results (99 % bandwidth)

Ambient temperature	22 °C	Relative humidity	33 %
---------------------	-------	-------------------	------

181673 112.wmf: 99 % bandwidth at the lower end of the assigned frequency band:

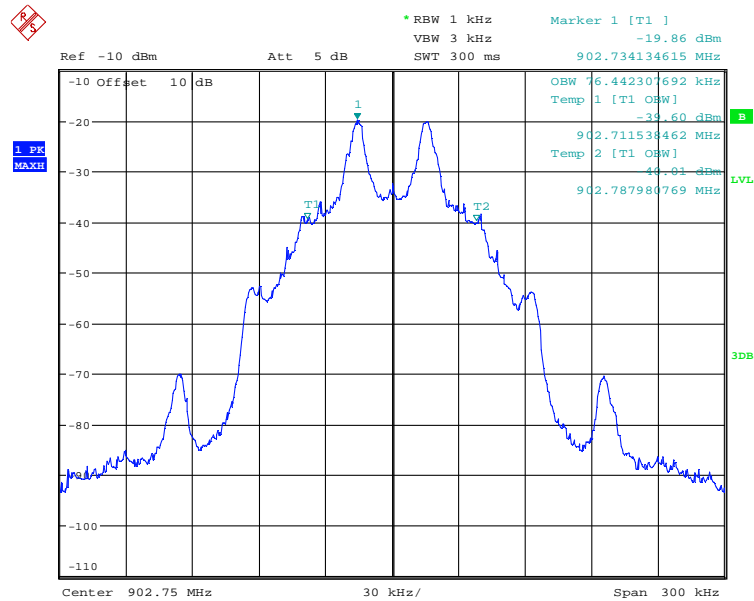

181673 113.wmf: 99 % bandwidth at the middle of the assigned frequency band:

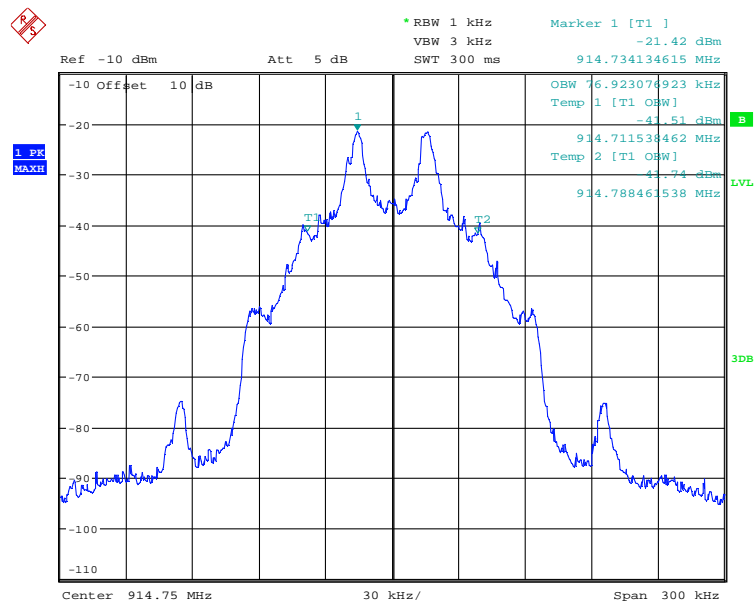

181673_114.wmf: 99 % bandwidth at the upper end of the assigned frequency band:

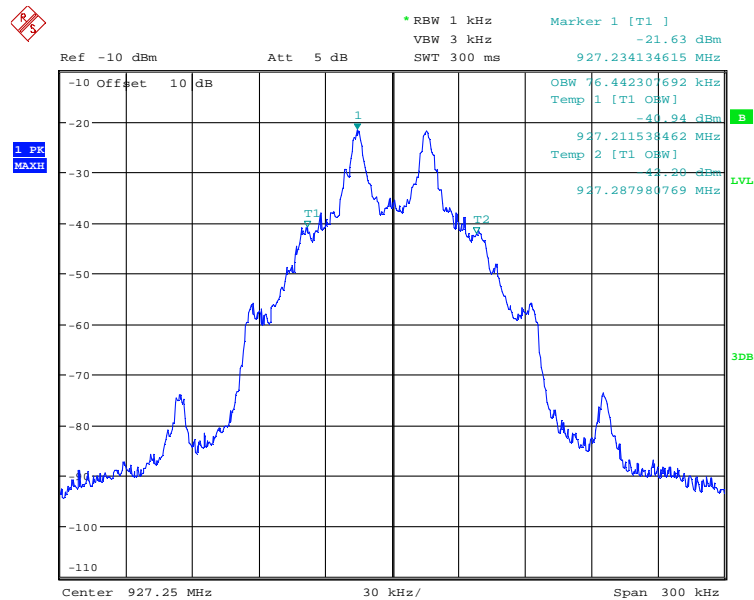

Channel number	Channel frequency [MHz]	99 % bandwidth [kHz]
1	902.750	76.442 kHz
25	914.750	76.923 kHz
50	927.250	76.442 kHz
Measurement uncertainty		+0.66 dB / -0.72 dB

Test equipment used (see clause 6):

1 - 3

5.2 Carrier frequency separation

5.2.1 Method of measurement (carrier frequency separation)

The calibration of the spectrum analyser has to be checked with the help of a known signal from a signal generator. The EUT has to be connected to the spectrum analyser via a low loss cable. If the EUT is not equipped with an antenna connector, a temporary antenna connector has to be installed. The EUT has to be switched on and the hopping function has to be enabled.

The following spectrum analyser settings according to [1] shall be used:

- Span: Wide enough to capture the peaks of two adjacent channels.
- Resolution bandwidth: Start with the Resolution bandwidth set to approximately 30% of the channel spacing; adjust as necessary to best identify the center of each individual channel.
- Video bandwidth \geq Resolution bandwidth.
- Sweep: Auto.
- Detector function: peak.
- Trace mode: Max hold.

After trace stabilisation the marker and the delta marker function will be used to determine the separation between the peaks of two adjacent channel signals.

The measurement will be performed at the upper, the lower end and the middle of the assigned frequency band.

Test set-up:

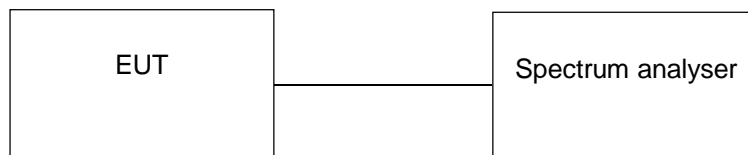

5.2.2 Test results (carrier frequency separation)

Ambient temperature	22 °C	Relative humidity	33 %
---------------------	-------	-------------------	------

181673_104.wmf: Channel separation at the lower end of the assigned frequency band:

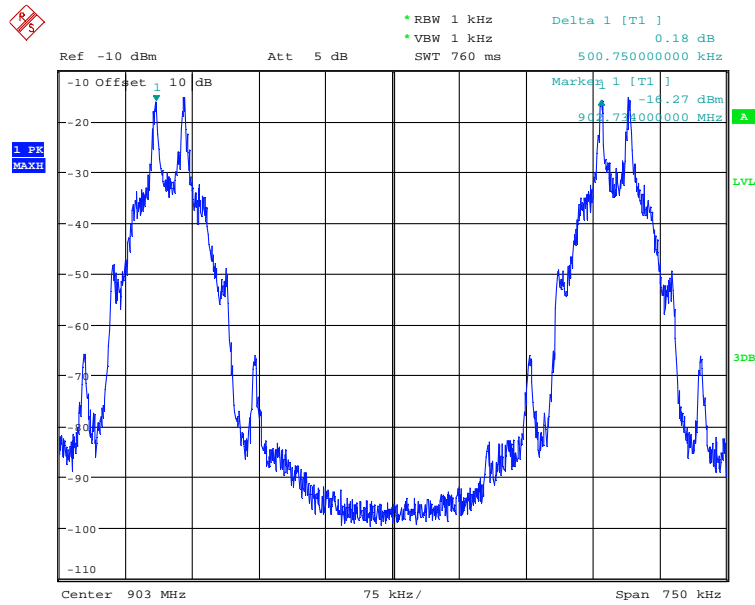

181673_105.wmf: Channel separation at the middle of the assigned frequency band:

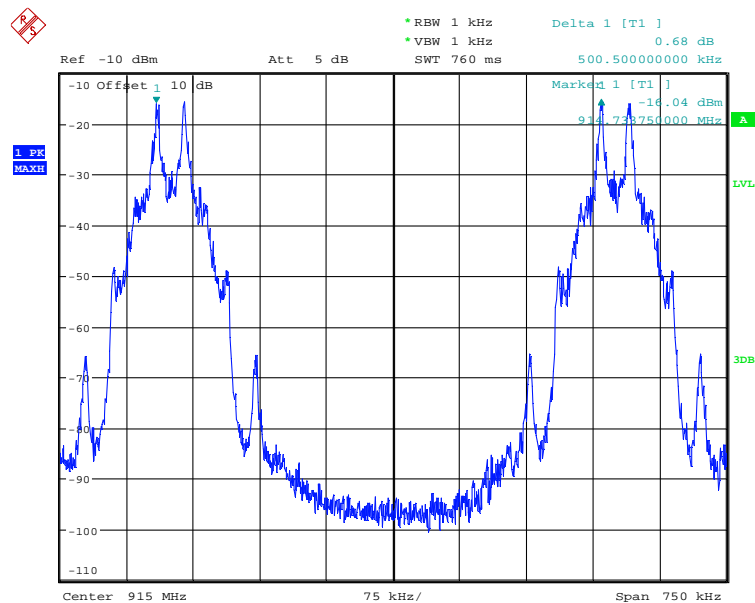

181673 .wmf: Channel separation at the upper end of the assigned frequency band:

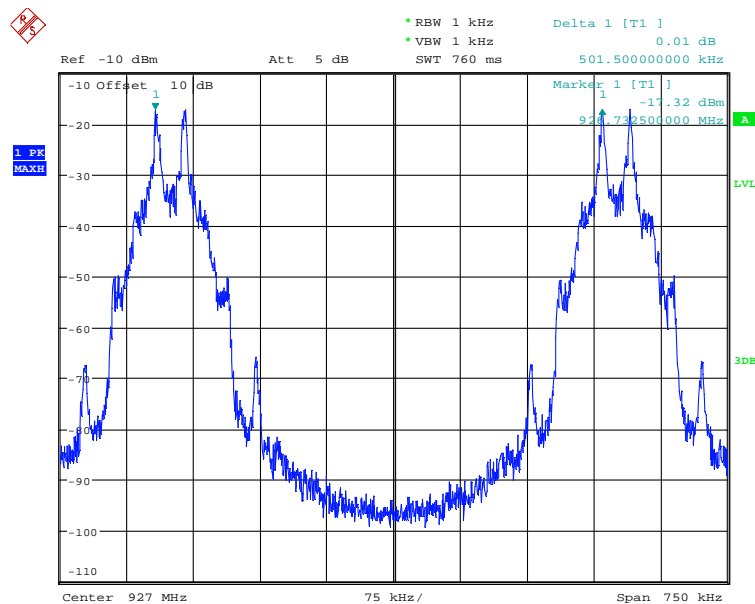

Remark: A smaller Resolution bandwidth was used in order to reach a better optical identification of the signal peaks.

Channel number	Channel frequency [MHz]	Channel separation [kHz]	Minimum limit [kHz]
1	902.750	500.750 kHz	79.327 kHz (the 20 dB bandwidth)
25	914.750	500.500 kHz	79.327 kHz (the 20 dB bandwidth)
50	927.250	501.500 kHz	79.327 kHz (the 20 dB bandwidth)
Measurement uncertainty			$<10^{-7}$

Test: Passed

Test equipment used (see chapter 6):

1 - 3

5.3 Number of hopping frequencies

5.3.1 Method of measurement (number of hopping frequencies)

The calibration of the spectrum analyser has to be checked with the help of a known signal from a signal generator. The EUT has to be connected to the spectrum analyser via a low loss cable. If the EUT is not equipped with an antenna connector, a temporary antenna connector has to be installed. The EUT has to be switched on and the hopping function has to be enabled.

The following spectrum analyser settings according to [1] shall be used:

- Span: The frequency band of operation. Depending on the number of channels the device supports, it may be necessary to divide the frequency range of operation across multiple spans, to allow the individual channels to be clearly seen.
- Resolution bandwidth: To identify clearly the individual channels, set the Resolution bandwidth to less than 30% of the channel spacing or the 20 dB bandwidth, whichever is smaller.
- Video bandwidth: ³ the resolution bandwidth.
- Sweep: Auto.
- Detector function: Peak.
- Trace mode: Max hold.

After trace stabilisation the number of hopping channels could be counted. It might be possible to divide the span into some sub ranges in order to clearly show all hopping frequencies.

Test set-up:

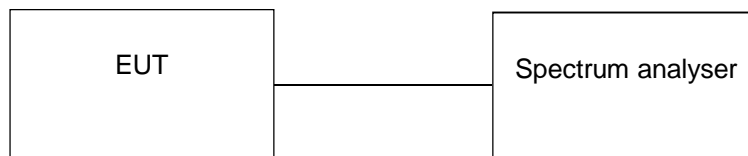

5.3.2 Test results (number of hopping frequencies)

Ambient temperature	22 °C
---------------------	-------

Relative humidity	33 %
-------------------	------

181673_107.wmf: Number of hopping channels:

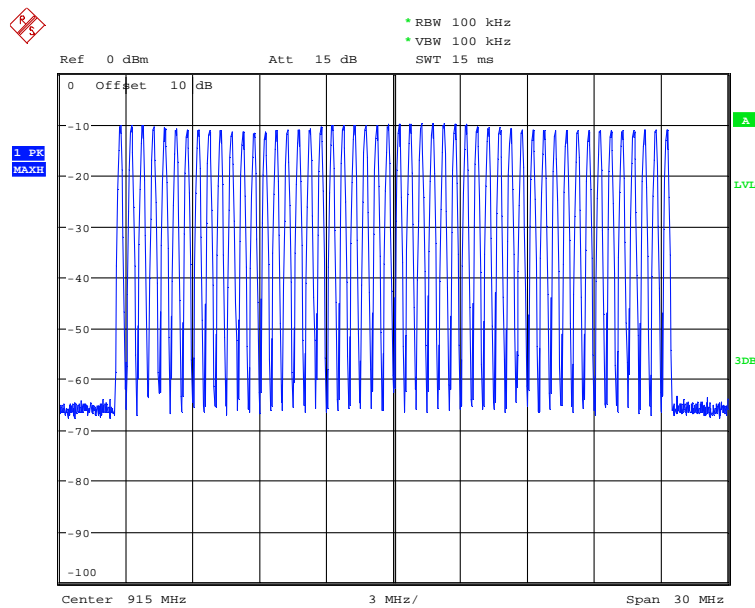

Remark: The Resolution bandwidth was set close to the 20 dB bandwidth in order to reach a better optical identification of the signal peaks.

Number of hopping channels	Limit
Operation mode 4	
50	At least 50

Test: Passed

Test equipment used (see clause 6):

1 - 3

5.4 Dwell time

5.4.1 Method of measurement (dwell time)

The calibration of the spectrum analyser has to be checked with the help of a known signal from a signal generator. The EUT has to be connected to the spectrum analyser via a low loss cable. If the EUT is not equipped with an antenna connector, a temporary antenna connector has to be installed. The EUT has to be switched on and the hopping function has to be enabled.

The following spectrum analyser settings according to [1] shall be used:

- Span: Zero, centered on a hopping channel.
- Resolution bandwidth shall be \leq channel spacing and where possible Resolution bandwidth should be set $\gg 1 / T$, where T is the expected dwell time per channel.
- Video bandwidth: ³ the resolution bandwidth.
- Sweep: As necessary to capture the entire dwell time per hopping channel; where possible use a video trigger and trigger delay so that the transmitted signal starts a little to the right of the start of the plot. The trigger level might need slight adjustment to prevent triggering when the system hops on an adjacent channel; a second plot might be needed with a longer sweep time to show two successive hops on a channel.
- Detector function: peak.
- Trace mode: Max hold.

The marker and delta marker function of the spectrum analyser will be used to determine the dwell time.

The measurement will be performed at the middle of the assigned frequency band.

Repeat the measurement using a longer sweep time to determine the number of hops over the period specified in the requirements. The sweep time shall be equal to, or less than, the period specified in the requirements. Determine the number of hops over the sweep time and calculate the total number of hops in the period specified in the requirements, using the following equation:

$$(\text{Number of hops in the period specified in the requirements}) = (\text{number of hops on spectrum analyzer}) \times (\text{period specified in the requirements} / \text{analyzer sweep time})$$

The average time of occupancy is calculated from the transmit time per hop multiplied by the number of hops in the period specified in the requirements. If the number of hops in a specific time varies with different modes of operation (data rate, modulation format, number of hopping channels, etc.), then repeat this test for each variation.

The measured transmit time and time between hops shall be consistent with the values described in the operational description for the EUT.

Test set-up:



5.4.2 Test results (dwell time)

Ambient temperature	22 °C	Relative humidity	33 %
---------------------	-------	-------------------	------

181673_111.wmf: Dwell time at the middle of the assigned frequency band (single hop):

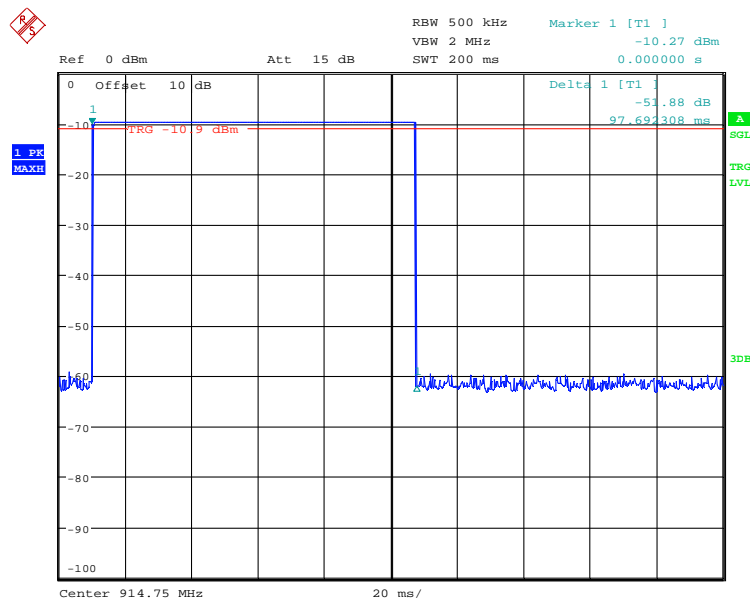

181673_110.wmf: Dwell time at the middle of the assigned frequency band (required period):

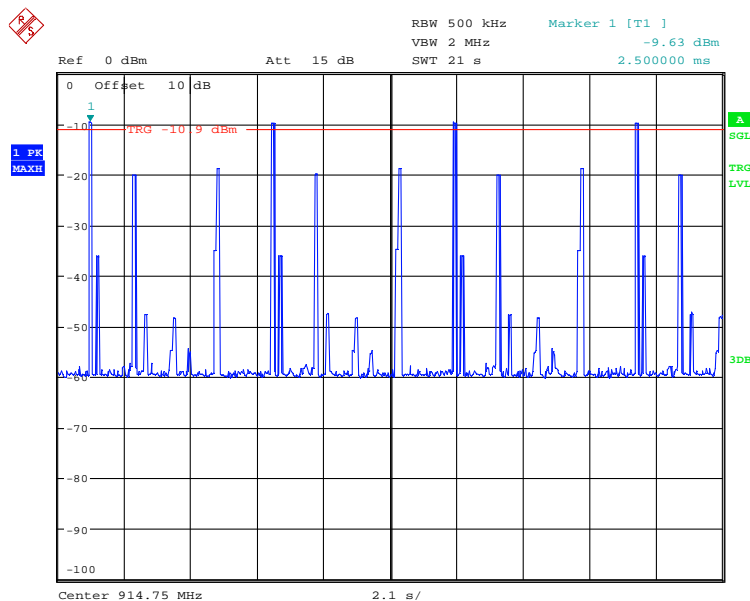

Channel number	Channel frequency [MHz]	t _{pulse} [ms]	Number of pulses	Dwell time [ms]	Limit [ms]
24	914.750	97.692	4	390.768	400.000
Measurement uncertainty				<10 ⁻⁷	

Test: Passed

Test equipment used (see clause 6):

1 - 3

5.5 Maximum peak output power

5.5.1 Method of measurement (maximum peak output power)

Because the EUT has no antenna connector, which presents the power delivered to the antenna, the peak value of the field strength was measured. The method of measurement is described under clause 5.6.2.3 (final measurement (30 MHz to 1 GHz)) of this test report with the exception that a peak detector was used. According to 11.12.2.2 e) [1] with this the field strength value the radiated peak power of the EUT was calculated. With the antenna gain of the EUTs antenna the conducted peak power was calculated.

5.5.2 Test results (maximum peak output power)

Ambient temperature	20 °C	Relative humidity	32 %
---------------------	-------	-------------------	------

Result measured with the peak detector:

Frequency (MHz)	Peak (dB μ V/m)	Meas. Time (ms)	Bandwidth (kHz)	Height (cm)	Pol.	Azimuth (deg)	Pos.
902.750	114.1	1000.0	120.000	100.0	Hor.	204.0	1
914.750	115.3	1000.0	120.000	150.0	Hor.	208.0	1
927.250	115.5	1000.0	120.000	150.0	Hor.	211.0	1
Measurement uncertainty				+2.2 dB / -3.6 dB			

The peak radiated output power was calculated with the following formula:

Calculated peak radiated output power [dBm (EIRP)] = (field strength [dB μ V/m] + 20 log(measuring distance [m]) - 104.8

The maximum peak output power was calculated with the following formula:

Maximum peak output power [dBm] = Calculated peak radiated output power [dBm] – antenna gain [dB]

Frequency (MHz)	Field strength (dB μ V/m)	Peak radiated power (dBm, EIRP)	Antenna gain (dBi)	Maximum peak conducted output power (dBm)	(W)
902.750	114.1	18.8	-4.5	23.3	0.214
914.750	115.3	20.0	-4.5	24.5	0.282
927.250	115.5	20.2	-4.5	24.7	0.295

Test: Passed

Test equipment used (see clause 6):

18 - 25

5.6 Radiated emissions

5.6.1 Method of measurement (radiated emissions)

The radiated emission measurement is subdivided into five stages.

- A preliminary measurement carried out in a fully anechoic chamber with a fixed antenna height in the frequency range 9 kHz to 1 GHz.
- A final measurement carried out on an outdoor test site without reflecting ground plane and a fixed antenna height in the frequency range 9 kHz to 30 MHz.
- A final measurement carried out on an open area test site with reflecting ground plane and various antenna height in the frequency range 30 MHz to 1 GHz.
- A preliminary measurement carried out in a fully anechoic chamber with fixed antenna distance and height in the frequency range above 1 GHz.
- A final measurement carried out in a fully anechoic chamber with a fixed antenna height in the frequency range above 1 GHz.

Preliminary measurement (9 kHz to 30 MHz):

In the first stage a preliminary measurement will be performed in a shielded room with a measuring distance of 3 meters. Table top devices will set up on a non-conducting turn device on the height of 1.5m. Floor-standing devices will be placed directly on the turntable/ground plane. The set-up of the Equipment under test will be in accordance to [1].

The frequency range 9 kHz to 30 MHz will be monitored with a spectrum analyser while the system and its cables will be manipulated to find out the configuration with the maximum emission levels if applicable. The EMI Receiver will be set to MAX Hold mode. The EUT and the measuring antenna will be rotated around their vertical axis to found the maximum emissions.

The resolution bandwidth of the spectrum analyser will be set to the following values:

Frequency range	Resolution bandwidth
9 kHz to 150 kHz	200 Hz
150 kHz to 30 MHz	10 kHz

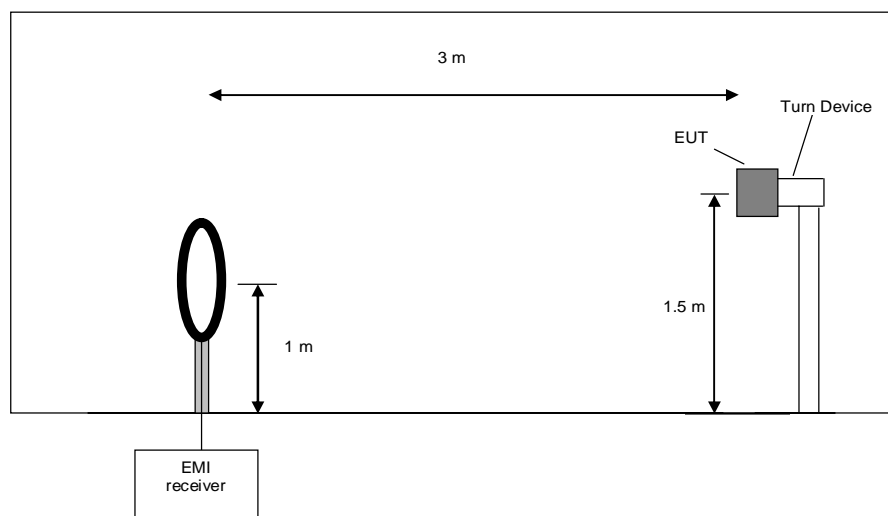

Preliminary measurement procedure:

Prescans were performed in the frequency range 9 kHz to 150 kHz and 150 kHz to 30 MHz.

Prescans were performed in the frequency range 30 MHz to 230 MHz and 230 MHz to 1 GHz.
The following procedure will be used:

1. Monitor the frequency range at horizontal polarisation and a EUT azimuth of 0 °.
2. Manipulate the system cables within the range to produce the maximum level of emission.
3. Rotate the EUT by 360 ° to maximize the detected signals.
4. Repeat 1) to 3) with the vertical polarisation of the measuring antenna.
5. Make a hardcopy of the spectrum.
6. Repeat 1) to 5) with the EUT raised by an angle of 0° (45°, 90°) according to 6.6.5.4 in [1].
7. Measure the frequency of the detected emissions with a lower span and resolution bandwidth to increase the accuracy and note the frequency value.

Final measurement (9 kHz to 30 MHz):

In the second stage a final measurement will be performed on an open area test site with no conducting ground plane in a measuring distances of 3 m, 10 m and 30 m. In the case where larger measuring distances are required the results will be extrapolated based on the values measured on the closer distances according to Section 15.31 (f) (2) [2]. The final measurement will be performed with a EMI Receiver set to Quasi Peak detector except for the frequency bands 9 kHz to 90 kHz and 110 kHz to 490 kHz where an average detector will be used according Section 15.209 (d) [2].

On the frequencies, which were detected during the preliminary measurements, the final measurement will be performed while rotating the EUT and the measuring antenna in the range of 0 ° to 360 ° around their vertical axis until the maximum value is found.

The resolution bandwidth of the EMI Receiver will be set to the following values:

Frequency range	Resolution bandwidth
9 kHz to 150 kHz	200 Hz
150 kHz to 30 MHz	9 kHz

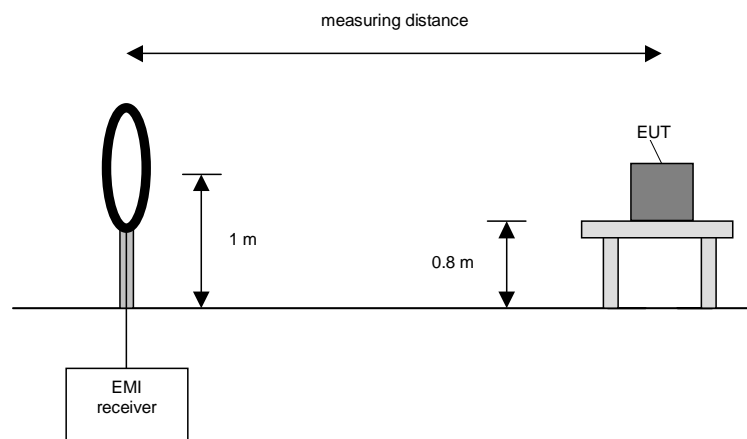

Final measurement procedure:

The following procedure will be used:

- 1) Monitor the frequency range with the measuring antenna at vertical orientation parallel to the EUT at an azimuth of 0 °.
- 2) Rotate the EUT by 360 ° to maximize the detected signals and note the azimuth and orientation.
- 3) Rotate the measuring antenna to find the maximum and note the value.
- 4) Rotate the measuring antenna and repeat steps 1) to 3) until the maximum value is found.
- 5) Repeat steps 1) to 4) with the other orthogonal axes of the EUT (if the EUT is a module and might be used in a handheld equipment application).

Preliminary measurement (30 MHz to 1 GHz)

In the first stage a preliminary measurement will be performed in a fully anechoic chamber with a measuring distance of 3 meter. Table top devices will set up on a non-conducting turn device on the height of 1.5m. Floor-standing devices will be placed directly on the turntable/ground plane. The setup of the Equipment under test will be in accordance to [1].

The frequency range 30 MHz to 1 GHz will be measured with an EMI Receiver set to MAX Hold mode and a resolution bandwidth of 120 kHz. The measurement will be performed in horizontal and vertical polarisation of the measuring antenna and while rotating the EUT in its vertical axis in the range of 0 ° to 360 °. This measurement is repeated after raising the EUT in 30° steps according 6.6.5.4 in [1].

The resolution bandwidth of the EMI Receiver will be set to the following values:

Frequency range	Resolution bandwidth
30 MHz to 230 MHz	120 kHz
230 MHz to 1 GHz	120 kHz

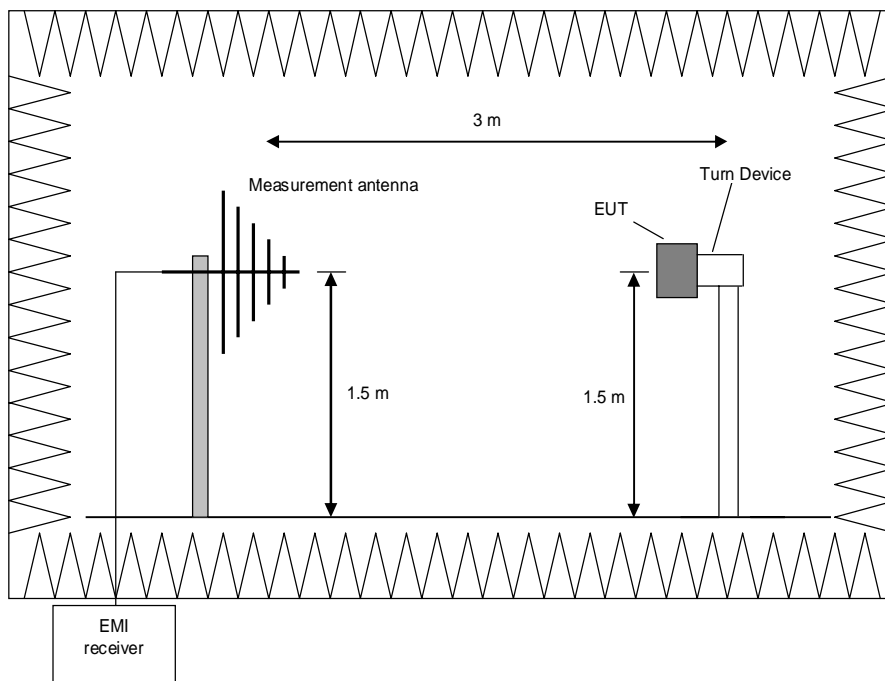

Procedure preliminary measurement:

Prescans were performed in the frequency range 30 MHz to 230 MHz and 230 MHz to 1 GHz.

The following procedure will be used:

1. Monitor the frequency range at horizontal polarisation and a EUT azimuth of 0 °.
2. Manipulate the system cables within the range to produce the maximum level of emission.
3. Rotate the EUT by 360 ° to maximize the detected signals.
4. Repeat 1) to 3) with the vertical polarisation of the measuring antenna.
5. Make a hardcopy of the spectrum.
6. Repeat 1) to 5) with the EUT raised by an angle of 0° (45°, 90°) according to 6.6.5.4 in [1].
7. Measure the frequency of the detected emissions with a lower span and resolution bandwidth to increase the accuracy and note the frequency value.

Final measurement (30 MHz to 1 GHz)

A final measurement on an open area test site will be performed on selected frequencies found in the preliminary measurement. During this test the EUT will be rotated in the range of 0 ° to 360 °, the measuring antenna will be set to horizontal and vertical polarisation and raised and lowered in the range from 1 m to 4 m to find the maximum level of emissions.

The resolution bandwidth of the EMI Receiver will be set to the following values:

Frequency range	Resolution bandwidth
30 MHz to 1 GHz	120 kHz

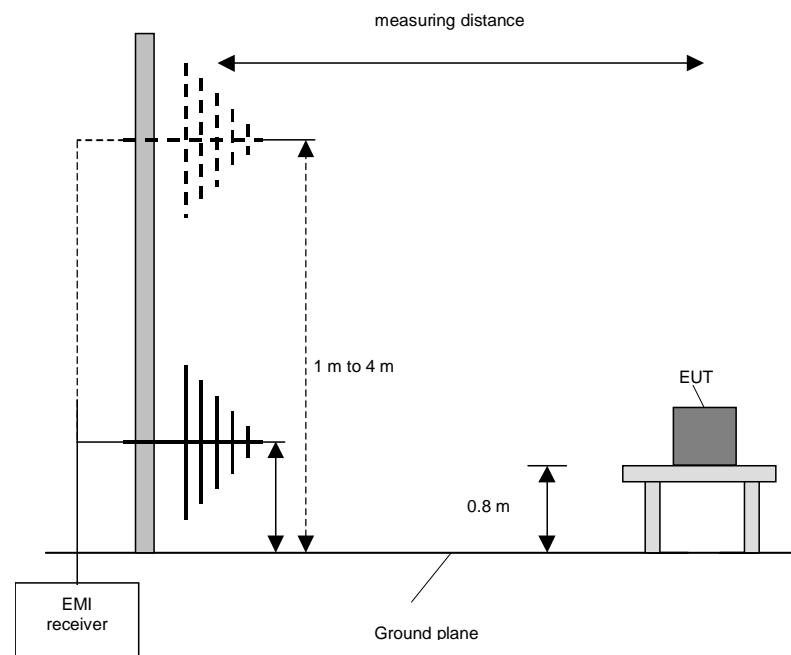

Procedure final measurement:

The following procedure will be used:

- 1) Measure on the selected frequencies at an antenna height of 1 m and a EUT azimuth of 23 °.
- 2) Move the antenna from 1 m to 4 m and note the maximum value at each frequency.
- 3) Rotate the EUT by 45 ° and repeat 2) until an azimuth of 337 ° is reached.
- 4) Repeat 1) to 3) for the other orthogonal antenna polarization.
- 5) Move the antenna and the turntable to the position where the maximum value is detected.
- 6) Measure while moving the antenna slowly +/- 1 m.
- 7) Set the antenna to the position where the maximum value is found.
- 8) Measure while moving the turntable +/- 45 °.
- 9) Set the turntable to the azimuth where the maximum value is found.
- 10) Measure with Final detector (QP and AV) and note the value.
- 11) Repeat 5) to 10) for each frequency.
- 12) Repeat 1) to 11) for each orthogonal axes of the EUT (because of EUT is a module and might be used in a handheld equipment application).

Preliminary and final measurement (1 GHz to 40 GHz)

This measurement will be performed in a fully anechoic chamber. Table top devices will set up on a non-conducting turn device on the height of 1.5m. The set-up of the Equipment under test will be in accordance to [1].

Preliminary measurement (1 GHz to 40 GHz)

The frequency range will be divided into different sub ranges depending of the frequency range of the used horn antenna. The spectrum analyser set to MAX Hold mode and a resolution bandwidth of 100 kHz. The measurement will be performed in horizontal and vertical polarisation of the measuring antenna and while rotating the EUT in its vertical axis in the range of 0 ° to 360 °. This measurement is repeated after raising the EUT in 30° steps according 6.6.5.4 in [1].

The resolution bandwidth of the EMI Receiver will be set to the following values:

Frequency range	Resolution bandwidth
1 GHz to 12 GHz	100 kHz
12 GHz to 18 GHz	100 kHz
18 GHz to 25 / 26.5 GHz	100 kHz
26.5 GHz to 40 GHz	100 kHz

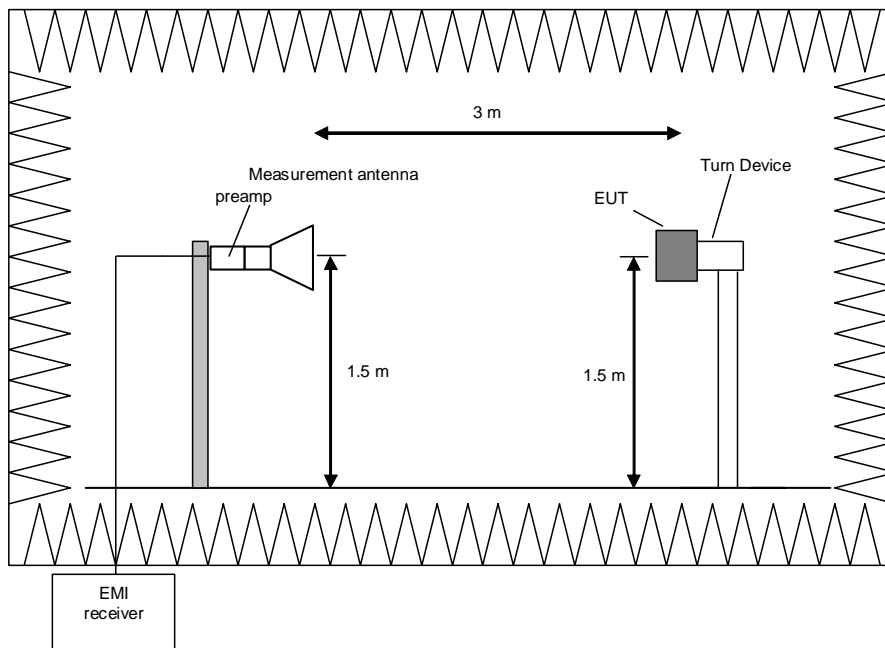

Procedure preliminary measurement:

Prescans were performed in the frequency range 1 to 40 GHz.

The following procedure will be used:

1. Monitor the frequency range at horizontal polarisation and a EUT azimuth of 0°.
2. Rotate the EUT by 360° to maximize the detected signals.
3. Repeat 1) to 2) with the vertical polarisation of the measuring antenna.
4. Make a hardcopy of the spectrum.
5. Repeat 1) to 4) with the EUT raised by an angle of 30° (60°, 90°, 120° and 150°) according to 6.6.5.4 in [1].
6. Measure the frequency of the detected emissions with a lower span and resolution bandwidth to increase the accuracy and note the frequency value.
7. The measurement antenna polarisation, with the according EUT position (Turntable and Turn device) which produces the highest emission for each frequency will be used for the final measurement. The six closest values to the applicable limit will be used for the final measurement.

Final measurement (1 GHz to 40 GHz)

The frequency range will be divided into different sub ranges depending of the frequency range of the used horn antenna. The EMI Receiver set to peak and average mode and a resolution bandwidth of 1 MHz. The measurement will be performed by rotating the turntable through 0 to 360° in the worst-case EUT orientation which was obtained during the preliminary measurements.

The resolution bandwidth of the EMI Receiver will be set to the following values:

Frequency range	Resolution bandwidth
1 GHz to 12 GHz	1 MHz
12 GHz to 18 GHz	1 MHz
18 GHz to 25 / 26.5 GHz	1 MHz
26.5 GHz to 40 GHz	1 MHz

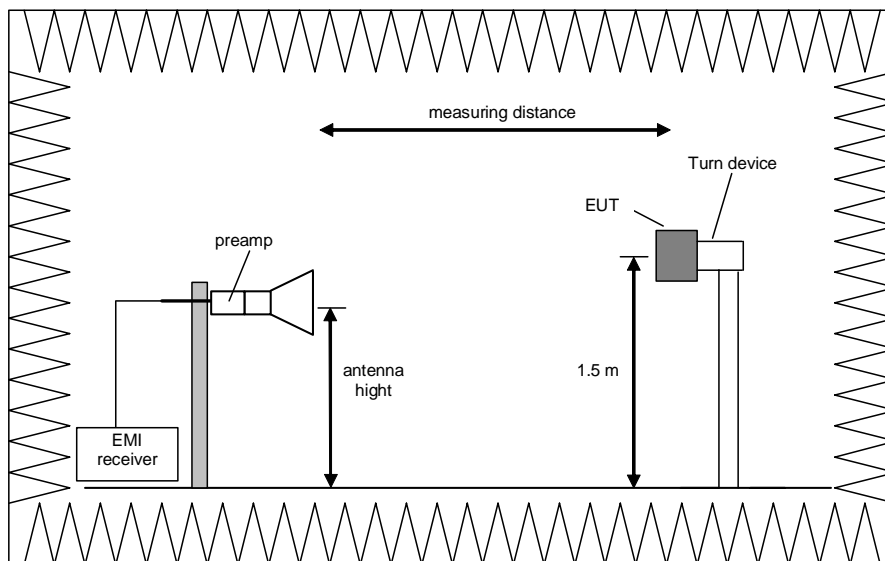

Procedure of measurement:

The measurements were performed in the frequency ranges 1 GHz to 12 GHz, 12 GHz to 18 GHz, 18 GHz to 25 /26.5 GHz and 26.5 GHz to 40 GHz.

The following procedure will be used:

- 1) Set the turntable and the turn device to obtain the worst-case emission for the first frequency identified in the preliminary measurements.
- 2) Set the measurement antenna polarisation to the orientation with the highest emission for the first frequency identified in the preliminary measurements.
- 3) Set the spectrum analyser to EMI mode with peak and average detector activated.
- 4) Rotate the turntable from 0° to 360° to find the TT Pos. that produces the highest emissions.
- 5) Note the highest displayed peak and average values
- 6) Repeat the steps 1) to 5) for each frequency detected during the preliminary measurements.

5.6.2 Test results (radiated emissions)

5.6.2.1 Preliminary radiated emission measurement (10 MHz to 10 GHz)

Ambient temperature	21 °C	Relative humidity	31 %
---------------------	-------	-------------------	------

Position of EUT:	The EUT was set-up on a turn device of a height of 1.5 m. The distance between EUT and antenna was 3 m.
Cable guide:	For detail information of test set-up and the cable guide refer to the pictures in annex A of this test report.
Test record:	All results are shown in the following.
Supply voltage:	During all measurements the EUT was supplied with 24 V DC by an external power supply.
Frequency range:	The preliminary measurement was carried out in the frequency range 10 MHz to 10 GHz according to [2].
Remark:	As pre-tests have shown, the emissions in the frequency range 10 MHz to 30 MHz are not depending on the transmitter operation mode. Therefore the emissions in this frequency range were measured only with the transmitter operates in operation mode 2.

Transmitter operates at the lower end of the assigned frequency band (operation mode 1)

Spurious emissions from 30 MHz to 1 GHz (operation mode 1, carrier notched):

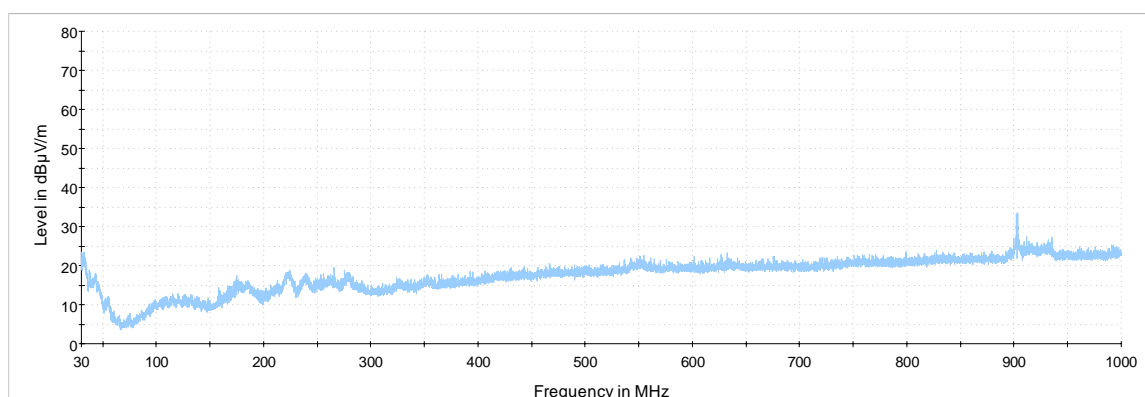

— Preview Result 1-PK+

The following frequencies were found outside the restricted bands during the preliminary radiated emission test:

- 32.280 MHz, 174.967 MHz, 224.291 MHz, 632.613 MHz, 899.848 MHz, 911.973 MHz, 902.750 MHz and 935.544 MHz.

The following frequency was found inside the restricted bands during the preliminary radiated emission test:

- 265.953 MHz.

These frequencies have to be measured on the open area test site. The result is presented in the following.

Spurious emissions from 1 GHz to 10 GHz (operation mode 1):

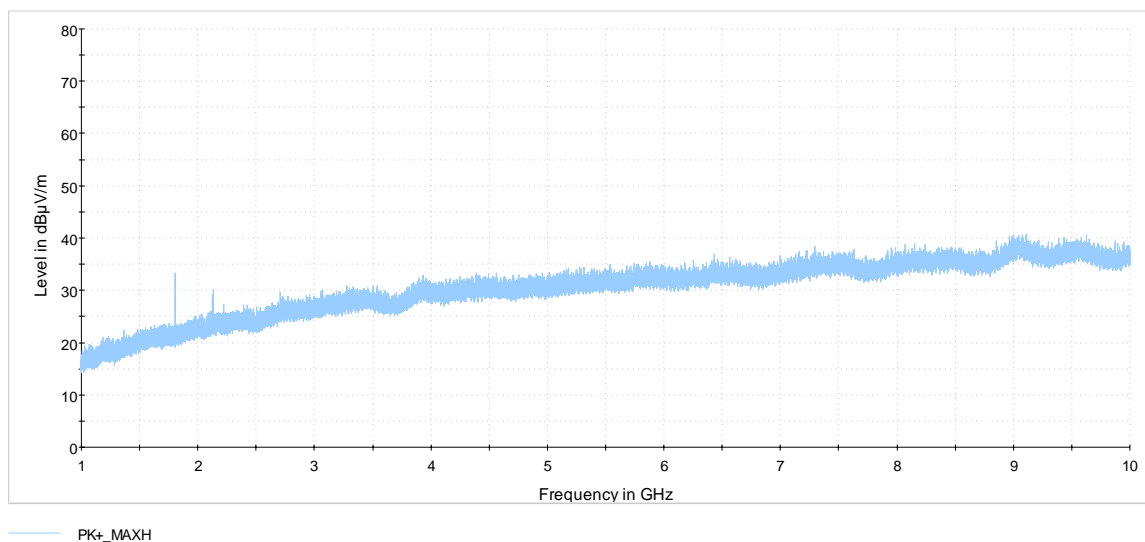

The following frequency was found outside the restricted bands during the preliminary radiated emission test:

- 2708.250 MHz, 3922.360 MHz, 7299.445 MHz, 8148.220 MHz and 9113.510 MHz.

The following frequencies were found inside the restricted bands during the preliminary radiated emission test:

- 1805.500 MHz and 2133.300 MHz.

These frequencies have to be measured in a final measurement. The results were presented in the following.

Transmitter operates on the middle of the assigned frequency band (operation mode 2)

Spurious emissions from 10 MHz to 30 MHz (operation mode 2):

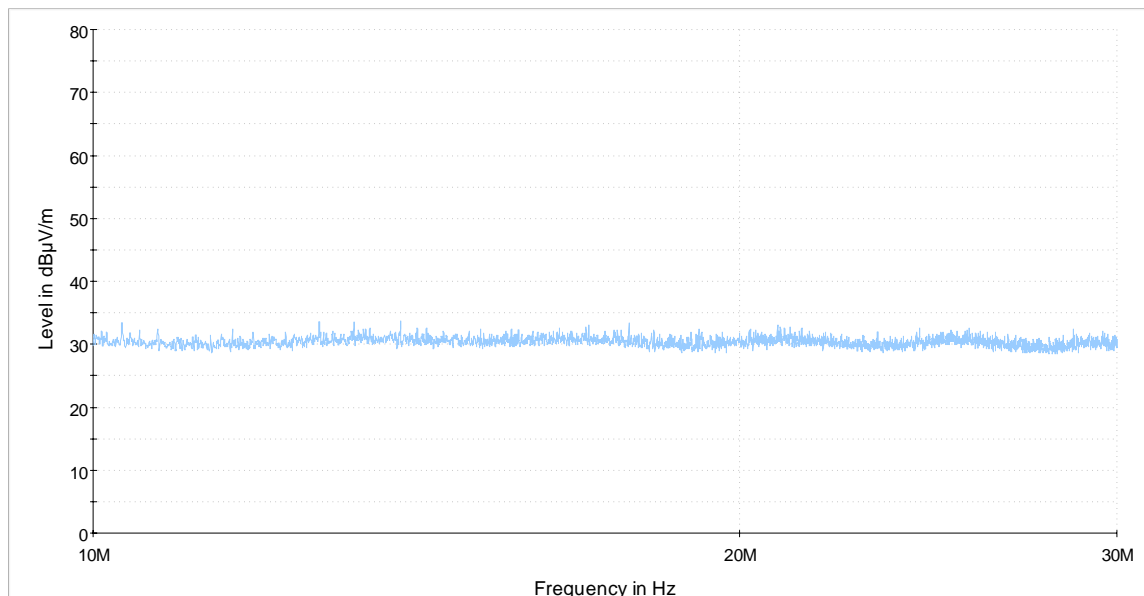

Preview Result 1-PK+

No significant frequencies above the noise floor of the system (max. 34 dBµV/m (measured with peak detector) at 3 m distance) were found during the preliminary radiated emission test, so no measurements were carried out on the outdoor test site.

Spurious emissions from 30 MHz to 1 GHz (operation mode 2, carrier notched):

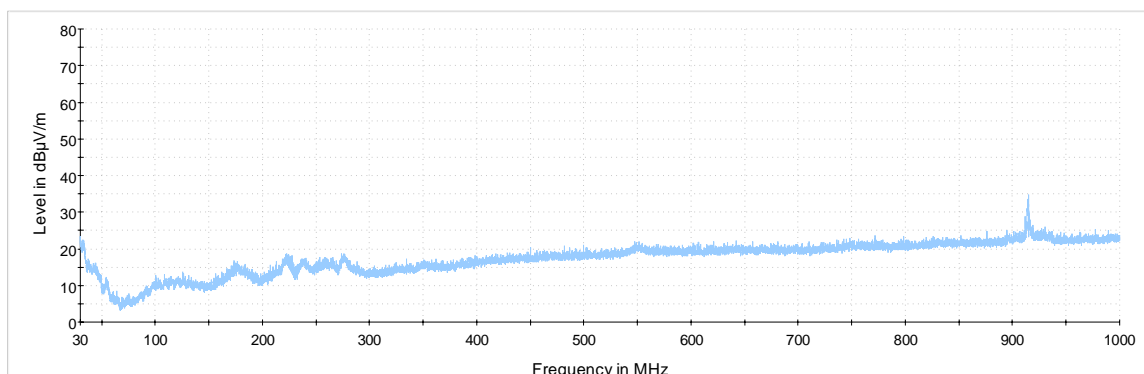

Preview Result 1-PK+

The following frequencies were found outside the restricted bands during the preliminary radiated emission test:

- 30.291 MHz, 173.706 MHz, 499.335 MHz, 772.002 MHz, 895.095 MHz, 912.021 MHz, 914.750 MHz, 916.338 MHz and 930.500 MHz.

The following frequency was found inside the restricted bands during the preliminary radiated emission test:

- 273.616 MHz.

These frequencies have to be measured on the open area test site. The result is presented in the following.

Spurious emissions from 1 GHz to 10 GHz (operation mode 2):

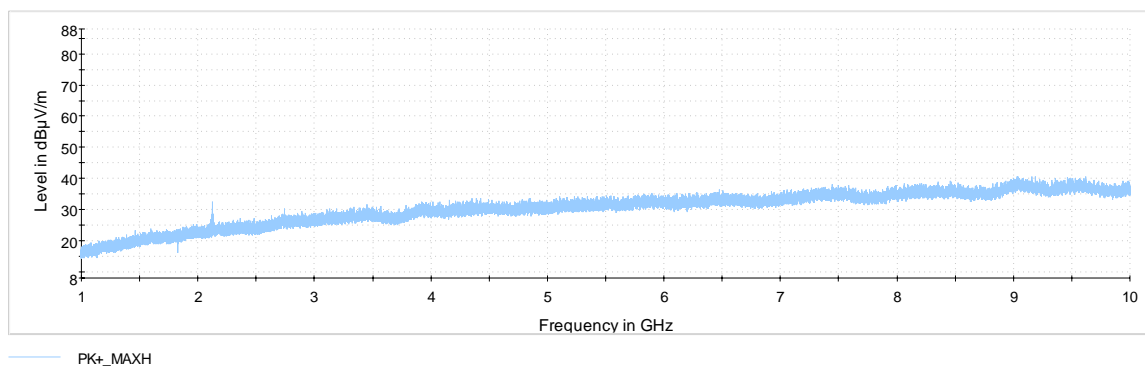

The following frequencies were found outside the restricted bands during the preliminary radiated emission test:

- 2127.740 MHz and 9579.615 MHz.

The following frequencies were found inside the restricted bands during the preliminary radiated emission test:

- 2744.250 MHz, 5147.173 MHz, 7454.342 MHz and 9043.215 MHz.

These frequencies have to be measured in a final measurement. The results were presented in the following.

Transmitter operates on the upper end of the assigned frequency (operation mode 3)

Spurious emissions from 30 MHz to 1 GHz (operation mode 3, carrier notched):

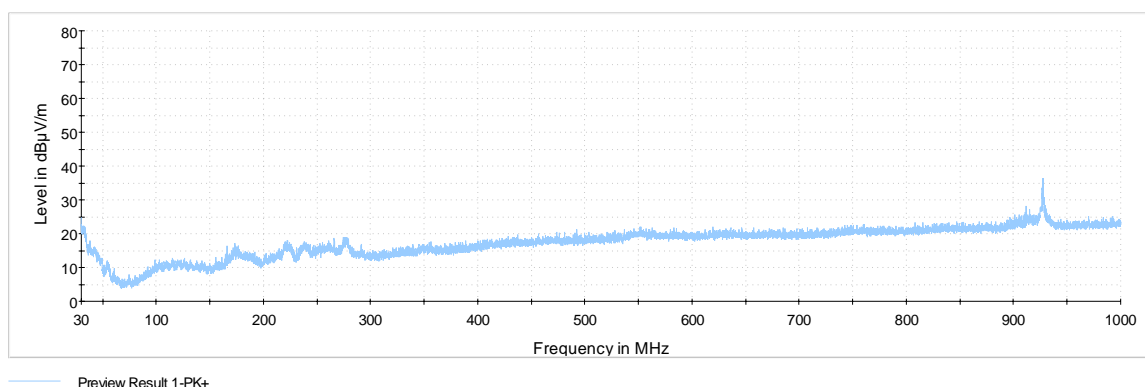

The following frequencies were found outside the restricted bands during the preliminary radiated emission test:

- 30.000 MHz, 173.512 MHz, 619.566 MHz, 912.021 MHz, 914.931 MHz, 927.250 MHz and 930.451 MHz.

The following frequencies were found inside the restricted bands during the preliminary radiated emission test:

- 266.001 MHz and 276.089 MHz.

These frequencies have to be measured on the open area test site. The result is presented in the following.

Spurious emissions from 1 GHz to 10 GHz (operation mode 3):

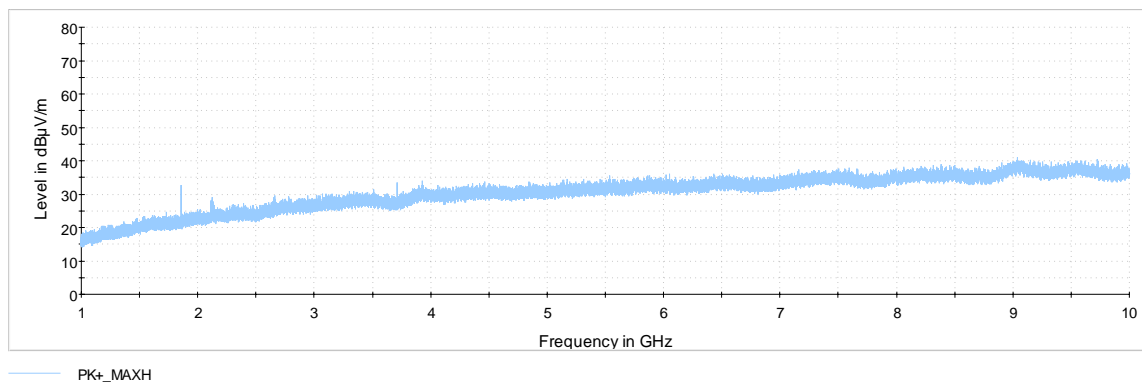

The following frequencies were found outside the restricted bands during the preliminary radiated emission test:

- 1854.500 MHz, 2128.040 MHz and 5173.988 MHz.

The following frequencies were found inside the restricted bands during the preliminary radiated emission test:

- 3709.000 MHz and 9039.230 MHz.

These frequencies have to be measured in a final measurement. The results were presented in the following.

Test equipment used (refer clause 6):

4 - 12, 14 - 17, 26, 31

5.6.2.2 Final radiated emission measurement (10 MHz to 30 MHz)

No significant frequencies above the noise floor of the system (max. 34 dB μ V/m (measured with peak detector) at 3 m distance) were found during the preliminary radiated emission test, so no final measurements were carried out on the outdoor test site.

5.6.2.3 Final radiated emission measurement (30 MHz to 1 GHz)

Ambient temperature	20 °C	Relative humidity	32 %
---------------------	-------	-------------------	------

Position of EUT: The EUT was set-up on a non-conducting table of a height of 0.8 m. The distance between EUT and antenna was 3 m.

Cable guide: For detail information of test set-up and the cable guide refer to the pictures in annex A of this test report.

Test record: All results are shown in the following.

Supply voltage: During all measurements the EUT was supplied with 24 V DC by an external power supply.

Test results: The test results were calculated with the following formula:

$$\text{Result [dB}\mu\text{V/m]} = \text{reading [dB}\mu\text{V]} + \text{cable loss [dB]} + \text{antenna factor [dB/m]} + 6 \text{ dB (used attenuator)}$$

The results of the standard subsequent measurement on the open area test site are indicated in the table below. The limits as well as the measured results (levels) refer to the above mentioned standard while taking account of the specified requirements for a 3 m measuring distance.

The measurement time with the quasi-peak measuring detector is 1 second.

Result measured with the quasi-peak detector:

Transmitter operates at the lower end of the assigned frequency band (operation mode 1)

Transmitter operates on the lower end of the assigned frequency band (operation mode 1)											
Frequency MHz	Result dB μ V/m	Limit dB μ V/m	Margin dB	Readings dB μ V	Antenna factor dB/m	Cable loss dB	Height cm	Azimuth deg	Restr. Band	Pol.	Pos.
30.280	28.3	93.8	65.5	2.2	19.5	0.6	154.0	8.0	No	Vert.	3
174.967	20.1	93.8	73.7	2.7	9.9	1.5	230.0	2.0	No	Vert.	1
224.291	24.7	93.8	69.1	7.0	10.1	1.6	132.0	106.0	No	Hor.	3
265.953	21.3	46.00	24.7	1.2	12.2	1.9	103.0	118.0	Yes	Hor.	1
632.613	29.2	93.8	64.6	0.5	19.8	2.9	291.0	337.0	No	Vert.	1
899.848	37.6	93.8	56.2	5.7	22.4	3.5	145.0	213.0	No	Hor.	2
902.750	113.8	Carrier		81.9	22.5	3.4	100.0	204.0	No	Hor.	1
911.973	38.2	93.8	55.6	6.1	22.7	3.4	145.0	206.0	No	Hor.	1
935.544	36.2	93.8	57.6	3.1	23.7	3.4	400.0	213.0	No	Vert.	1
Measurement uncertainty						+2.2 dB / -3.6 dB					

Transmitter operates at the middle of the assigned frequency band (operation mode 2)

Transmitter operates on the middle of the assigned frequency band (operation mode 2)											
Frequency MHz	Result dB μ V/m	Limit dB μ V/m	Margin dB	Readings dB μ V	Antenna factor dB/m	Cable loss dB	Height cm	Azimuth deg	Restr. Band	Pol.	Pos.
30.291	32.6	95.0	62.4	6.5	19.5	0.6	156.0	4.0	No	Vert.	3
173.706	17.6	95.0	77.4	0.1	10.0	1.5	128.0	8.0	No	Vert.	1
273.616	21.5	46.00	24.5	1.2	12.4	1.9	103.0	253.0	Yes	Hor.	3
499.335	28.1	95.0	66.9	2.2	17.4	2.5	363.0	18.0	No	Vert.	1
772.002	31.8	95.0	63.2	1.1	21.5	3.2	122.0	21.0	No	Vert.	1
895.095	33.7	95.0	61.3	1.9	22.3	3.5	100.0	301.0	No	Hor.	2
912.021	37.5	95.0	57.5	5.4	22.7	3.4	100.0	295.0	No	Hor.	2
914.750	115.0	Carrier		82.8	22.8	3.4	150.0	208.0	No	Hor.	1
916.338	35.9	95.0	59.1	3.6	22.9	3.4	150.0	213.0	No	Hor.	1
930.500	40.6	95.0	54.4	7.7	23.5	3.4	400.0	302.0	No	Vert.	2
Measurement uncertainty						+2.2 dB / -3.6 dB					

Transmitter operates at the upper end of the assigned frequency band (operation mode 3)

Transmitter operates on the upper end of the assigned frequency band (operation mode 3)											
Frequency MHz	Result dB μ V/m	Limit dB μ V/m	Margin dB	Readings dB μ V	Antenna factor dB/m	Cable loss dB	Height cm	Azimuth deg	Restr. Band	Pol.	Pos.
30.000	30.6	95.2	64.6	4.4	19.6	0.6	104.0	180.0	No	Vert.	1
173.512	18.0	95.2	77.2	0.5	10	1.5	187.0	94.0	No	Hor.	1
266.001	22.2	46.0	23.8	2.1	12.2	1.9	110.0	119.0	Yes	Hor.	1
276.089	20.2	46.0	25.8	-0.1	12.4	1.9	112.0	115.0	Yes	Hor.	2
619.566	30.2	95.2	65.0	1.8	19.6	2.8	391.0	351.0	No	Hor.	3
912.021	36.8	95.2	58.4	4.7	22.7	3.4	150.0	211.0	No	Hor.	2
914.931	34.5	95.2	60.7	2.3	22.8	3.4	150.0	214.0	No	Hor.	1
927.250	115.2	Carrier		82.4	23.4	3.4	150.0	211.0	No	Hor.	1
930.451	36.0	95.2	59.2	3.1	23.5	3.4	150.0	208.0	No	Hor.	2
Measurement uncertainty						+2.2 dB / -3.6 dB					

Test: Passed

Test equipment used (see clause 6):

22, 24, 27 - 30

5.6.2.4 Final radiated emission measurement (1 GHz to 10 GHz)

Ambient temperature	21 °C	Relative humidity	35 %
---------------------	-------	-------------------	------

Position of EUT: The EUT was set-up on a turn device of a height of 1.5 m. The distance between EUT and antenna was 3 m.

Cable guide: For detail information of test set-up and the cable guide refer to the pictures in annex A of this test report.

Test record: All results are shown in the following.

Supply voltage: During all measurements the EUT was supplied with 24 V DC by an external power supply.

Resolution bandwidth: For all measurements a resolution bandwidth of 1 MHz was used.

Test results: The test results were calculated with the following formula:

$$\text{Result [dB}\mu\text{V/m]} = \text{reading [dB}\mu\text{V]} + \text{cable loss [dB]} + \text{antenna factor [dB/m]} - \text{preamp [dB]}$$

Transmitter operates at the lower end of the assigned frequency band (operation mode 1)

Frequency [MHz]	MaxPeak [dBμV/m]	Average [dBμV/m]	Limit [dBμV/m]	Margin (dB)	Pol	Azimuth (deg)	Elevation (deg)	Corr. (dB)	Restr. Band
1805.500	---	30.6	54.00	23.4	Vert.	0.0	0.0	-13.0	No
	38.7	---	74.00	35.3					
2133.300	---	24.1	54.00	29.9	Hor.	271.0	30.0	-11.0	No
	41.4	---	74.00	32.6					
2708.250	---	26.2	54.00	27.8	Vert.	0.0	90.0	-8.0	Yes
	37.7	---	74.00	36.3					
3922.360	---	29.0	54.00	25.0	Hor.	90.0	120.0	-3.0	Yes
	41.7	---	74.00	32.3					
7299.445	---	34.1	54.00	19.9	Hor.	338.0	60.0	5.0	Yes
	46.9	---	74.00	27.1					
8148.220	---	34.2	54.00	19.8	Vert.	195.0	30.0	6.0	Yes
	46.8	---	74.00	27.2					
9113.510	---	36.7	54.00	17.3	Vert.	258.0	30.0	8.0	Yes
	48.8	---	74.00	25.2					
Measurement uncertainty					+2.2 dB / -3.6 dB				

Transmitter operates at the middle of the assigned frequency band (operation mode 2)

Frequency [MHz]	MaxPeak [dB μ V/m]	Average [dB μ V/m]	Limit [dB μ V/m]	Margin (dB)	Pol	Azimuth (deg)	Elevation (deg)	Corr. (dB)	Restr. Band
2127.740	---	27.0	54.00	27.0	Hor.	32.0	0.0	-11.0	No
	42.3	---	74.00	31.7					
2744.250	---	26.8	54.00	27.2	Vert.	12.0	60.0	-8.0	Yes
	38.5	---	74.00	35.5					
5147.173	---	29.8	54.00	24.2	Hor.	0.0	150.0	-1.0	Yes
	42.7	---	74.00	31.3					
7454.342	---	33.7	54.00	20.3	Vert.	0.0	150.0	6.0	Yes
	45.7	---	74.00	28.3					
9043.215	---	37.9	54.00	16.1	Vert.	244.0	60.0	9.0	Yes
	50.5	---	74.00	23.5					
9579.615	---	36.9	54.00	17.1	Vert.	0.0	30.0	8.0	No
	49.4	---	74.00	24.6					
Measurement uncertainty				+2.2 dB / -3.6 dB					

Transmitter operates at the upper end of the assigned frequency band (operation mode 3)

Frequency [MHz]	MaxPeak [dB μ V/m]	Average [dB μ V/m]	Limit [dB μ V/m]	Margin (dB)	Pol	Azimuth (deg)	Elevation (deg)	Corr. (dB)	Restr. Band
1854.500	36.2	---	74.0	37.8	Vert.	347.0	0.0	-13.0	No
	---	26.7	54.0	27.3					
2128.040	41.1	---	74.0	32.9	Vert.	347.0	30.0	-11.0	No
	---	27.1	54.0	26.9					
3709.000	---	29.1	54.0	24.9	Vert.	49.0	0.0	-6.0	Yes
	39.9	---	74.0	34.1					
5173.988	---	30.6	54.0	23.4	Vert.	347.0	30.0	-1.0	No
	43.0	---	74.0	31.0					
9039.230	---	37.8	54.0	16.2	Vert.	0.0	120.0	9.0	Yes
	49.7	---	74.0	24.3					
Measurement uncertainty				+2.2 dB / -3.6 dB					

Test: Passed

Test equipment used (see clause 6):

4 - 6, 8 - 9, 11 - 12, 14 - 17, 26

5.7 Conducted emissions on power supply lines (150 kHz to 30 MHz)

5.7.1 Method of measurement

This test will be carried out in a shielded chamber. Tabletop devices will set up on a non-conducting support with a size of 1 m by 1.5 m and a height of 80 cm above the ground plane. Floor-standing devices will be placed directly on the ground plane. The setup of the Equipment under test will be in accordance to [1].

The frequency range 150 kHz to 30 MHz will be measured with an EMI Receiver set to MAX Hold mode with peak and average detector and a resolution bandwidth of 9 kHz. A scan will be carried out on the phase (or plus pole in case of DC powered devices) of the AC mains network. If levels detected 10 dB below the appropriate limit, this emission will be measured with the average and quasi-peak detector on all lines.

Frequency range	Resolution bandwidth
150 kHz to 30 MHz	9 kHz

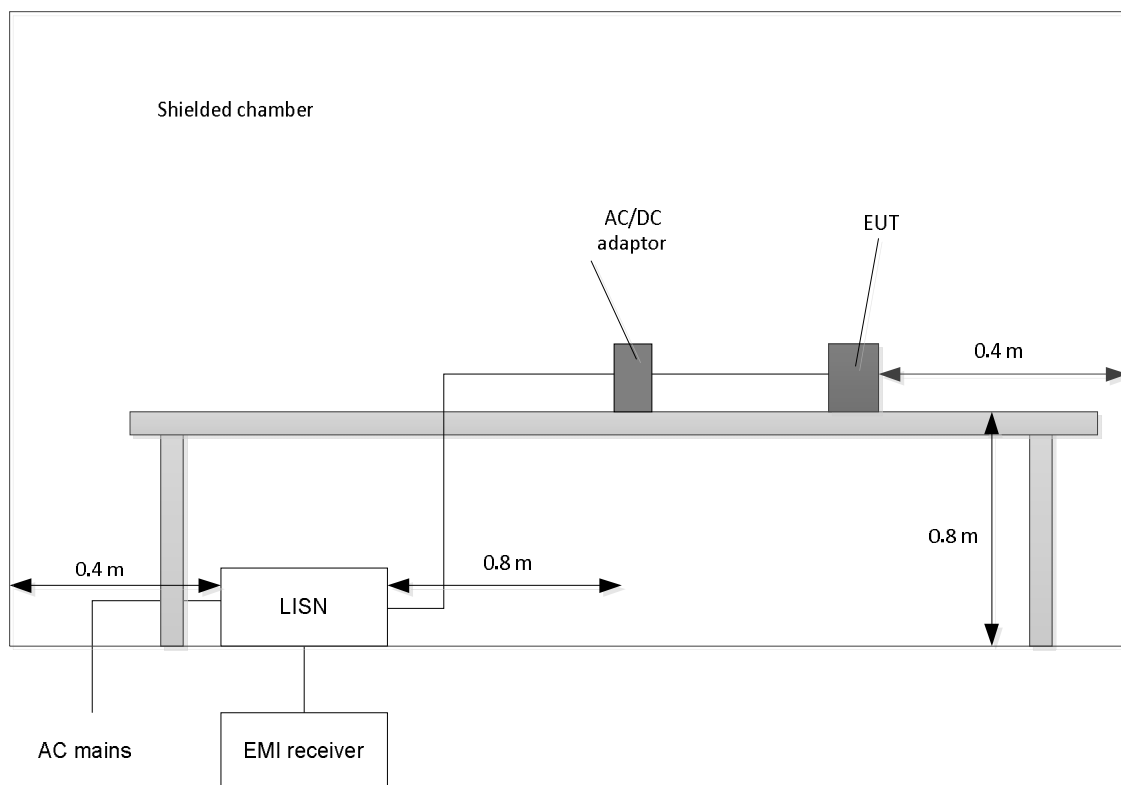

5.7.2 Test results (conducted emissions on power supply lines)

Ambient temperature	20 °C	Relative humidity	30 %
---------------------	-------	-------------------	------

Position of EUT:	The EUT was set-up on a non-conducting table of a height of 0.8 m.
Cable guide:	The cables of the EUT were fixed on the non-conducting table. For further information of the cable guide refer to the pictures in annex A of this test report.
Test record:	All results are shown in the following.
Supply voltage:	During this test the EUT was powered with 24 V _{DC} by the Mini-PS-100-240AC/24DC/1.3 from PHOENIX CONTACT, which was itself supplied with 120 V _{AC} / 60 Hz.

The curves in the diagram only represent for each frequency point the maximum measured value of all preliminary measurements which were made for each power supply line. The top measured curve represents the peak measurement and the bottom measured curve the average measurement. The quasi-peak measured points are marked ◆ by and the average measured points by ▼.

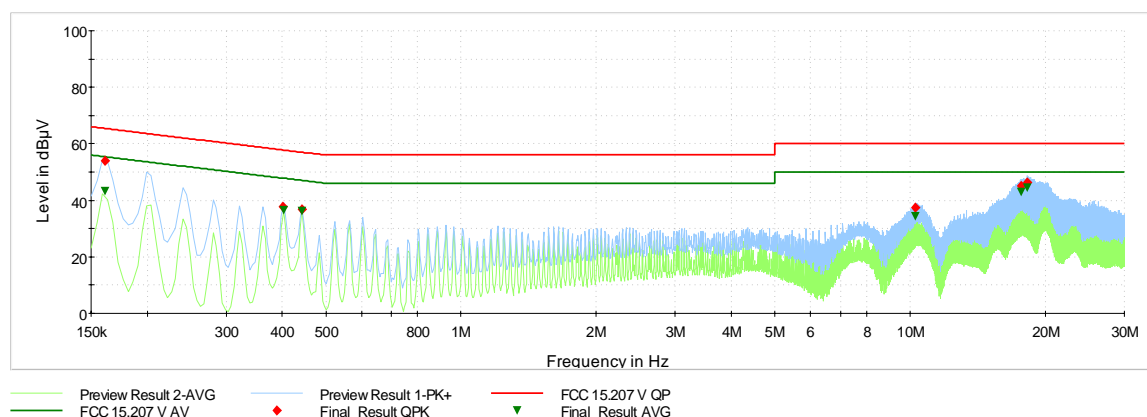

Remark: The limits of FCC 15.207 are identical to [3]

Frequency (MHz)	QuasiPeak (dB μ V)	Average (dB μ V)	Limit (dB μ V)	Margin (dB)	Meas. Time (ms)	Bandwidth (kHz)	Line	PE	Corr. (dB)
0.160800	54.1	---	65.4	11.3	5000.0	9.000	N	GND	9.8
0.160800	---	43.2	55.4	12.2	5000.0	9.000	N	FLO	9.8
0.401100	37.8	---	57.8	20.0	5000.0	9.000	L1	FLO	9.9
0.402000	---	36.5	47.8	11.3	5000.0	9.000	L1	FLO	9.9
0.441600	---	36.2	47.0	10.8	5000.0	9.000	L1	GND	9.9
0.442500	36.7	---	57.0	20.3	5000.0	9.000	L1	FLO	9.9
10.288500	---	34.3	50.0	15.7	5000.0	9.000	L1	FLO	10.6
10.290300	37.5	---	60.0	22.5	5000.0	9.000	L1	GND	10.6
17.643300	---	43.1	50.0	6.9	5000.0	9.000	N	GND	10.9
17.645100	45.2	---	60.0	14.8	5000.0	9.000	N	GND	10.9
18.245400	---	44.6	50.0	5.4	5000.0	9.000	N	GND	10.9
18.248100	46.0	---	60.0	13.7	5000.0	9.000	N	GND	10.9
Measurement uncertainty						±2.8 dB			

Test: Passed

Test equipment used (refer clause 6):

22, 24, 27 - 30

6 Test equipment and ancillaries used for tests

No.	Test equipment	Type	Manufacturer	Serial No.	PM. No.	Cal. Date	Cal Due
1	Spectrum Analyser	FSU46	Rohde & Schwarz	200125	480956	31.10.2018	10.2019
2	RF attenuator	WA8-10	Weinschel	7538	410112	Calibration not necessary	
3	Test fixture	-	PHOENIX TESTLAB	-	410160	Calibration not necessary	
4	Antenna mast	AS615P	Deisel	615/310	480187	Calibration not necessary	
5	Fully anechoic chamber M20	B83117-E2439-T232	Albatross Projects	103	480303	Calibration not necessary	
6	Turntable	DS420 HE	Deisel	420/620/00	480315	Calibration not necessary	
7	Antenna (Bilog)	CBL6112B	Schaffner (Chase)	2688	480328	19.06.2017	06.2020
8	Multiple Control Unit	MCU	Maturo	MCU/043/971107	480832	Calibration not necessary	
9	Software	WMS32	Rohde & Schwarz		481800	Calibration not necessary	
10	RF-cable No.36	Sucoflex 106B	Suhner	0587/6B	480865	Calibration not necessary	
11	Turn device	TDF 1.5- 10Kg	Maturo	15920215	482034	Calibration not necessary	
12	EMI Receiver / Spectrum Analyser	ESW44	Rohde & Schwarz	101635	482467	29.03.2018	03.2019
13	Loop antenna	HFH2-Z2	Rohde & Schwarz	100417	481912	10.01.2019	01.2020
14	Preamplifier 100 MHz – 16 GHz	AFS6-00101600-23-10P-6-R	Narda MITEQ	2011215	482333	10.07.2018	07.2020
15	Highpass filter	WHKX12-935-1000-15000-40ST	Wainwright Instruments	12	482908	Calibration not necessary	
16	RF-cable No.3	Sucoflex 106B	Suhner	0563/6B	480670	Calibration not necessary	
17	RF-Cable No. 40	Sucoflex 106B	Suhner	0708/6B	481330	Calibration not necessary	
18	Open area test site M6	Freifeld M6	Phoenix Contact	-	480085	Calibration not necessary	
19	Antenna mast	MA240-0	Inn-Co	MA240-0/030/6600603	480086	Calibration not necessary	
20	Turntable	DS412	Deisel	412/316	480087	Calibration not necessary	
21	Controller	HD100	Deisel	100/349	480139	Calibration not necessary	
22	Software	EMC32	Rohde & Schwarz	100061	481022	Calibration not necessary	
23	Antenna (Bilog)	CBL6111D	Schaffner / Teseq	25761	480894	19.10.2017	10.2020
24	EMI Receiver / Spectrum Analyser	ESIB 26	Rohde & Schwarz	100292	481182	28.02.2018	02.2020
25	Attenuator 6 dB	WA2-6	Weinschel	8254	410119	Calibration not necessary	
26	Antenna (Log.Per.)	HL050	Rohde & Schwarz	100438	481170	09.10.2017	10.2020
27	Transient Filter Limiter	CFL 9206A	Teseq	38268	481982	14.03.2018	03.2020
28	Artificial Network	NSLK8128	Schwarzbeck	8128161	480138	13.03.2018	03.2020
29	Shielded chamber M4	B83117-S1-X158	Siemens	190075	480088	Calibration not necessary	
30	AC power supply	AC6803A AC source 2000VA	Keysight	JPVJ002509	482350	Calibration not necessary	
31	Tunable Notch Filter	WRCA800/960-0.2/40-6EEK	Wainwright Instruments	15	480414	Calibration not necessary	

7 Test site Validation

Test equipment	PM. No.	Frequency range	Type of validation	According to	Val. Date	Val Due
OATS M6	480085	30 – 1000 MHz	NSA	ANSI C63.4-2014	25.10.2018	24.10.2020
Fully anechoic chamber M20	480303	1 -18 GHz	SVSWR	CISPR 16-1-4 Amd. 1	13.07.2018	12.07.2020
Shielded chamber M4	480088	9 kHz – 30 MHz	GND-Plane	ANSI C63.4-2014	06.11.2018	05.11.2020

8 Report history

Report Number	Date	Comment
F181673E3	18.03.2019	Document created

9 List of annexes

Annex A Test set-up photographs

8 pages